



3 1761 06705942 8

57

*Belmont 10/22/22
due 1/20/23*

PRESENTED TO
THE COLEMAN LIBRARY
BY
PROFESSOR E. S. MOORE

E. S. Moore
Digitized by the Internet Archive
in 2007 with funding from
Microsoft Corporation

COLEMAN LIBRARY
OF
GEOLOGICAL SCIENCES
UNIVERSITY OF TORONTO
BOOKS TO BE RETURNED WITHIN ~~ONE WEEK~~
THIS BOOK BELONGS IN *Mineralogy* *34*

MINERALOGY .



THE MACMILLAN COMPANY
NEW YORK • BOSTON • CHICAGO
DALLAS • SAN FRANCISCO

MACMILLAN & CO., LIMITED
LONDON • BOMBAY • CALCUTTA
MELBOURNE

THE MACMILLAN CO. OF CANADA, LTD.
TORONTO

34

MINERALOGY,

AN INTRODUCTION TO
THE THEORETICAL AND PRACTICAL
STUDY OF MINERALS 0

BY

ALEXANDER HAMILTON PHILLIPS, D.Sc.

PROFESSOR OF MINERALOGY IN PRINCETON
UNIVERSITY

1) New York
2) THE MACMILLAN # COMPANY
3) 1912

All rights reserved

COPYRIGHT, 1912,
By THE MACMILLAN COMPANY.

Set up and electrotyped. Published October, 1912.



Norwood Press
J. S. Cushing Co. — Berwick & Smith Co.
Norwood, Mass., U.S.A.

PREFACE

THE object of this book is to bring together for the beginner, in concise form and under one cover, the facts and basic principles of the several branches of mineralogy, unadulterated by an excess of data. It is, therefore, not a book of reference, but it takes the student along the various branches of the subject to a point from which, if he wishes to continue, he will be in a position to appreciate and to use the advanced literature and books on the subject.

The system of Dana has been followed to a great extent, as that is the book of reference which is largely used by the American student, though other sources have been freely consulted in the compilation of this volume. In Part I, Crystallography, the thirty-two types have been described for completeness, even though there are no minerals crystallizing in some of them. The names used are those of Miers, as they embody the symmetry of the type and thus require very little memory on the part of the student. Dana's names are given in each case under the term "class."

The old method of deriving the hemihedrons, etc., from the holohedrons has been retained and may meet with criticism, but it is a simple method of determining what forms are possible to combine on crystals of lower symmetry. I have always found it a very material aid to the student, leaving no false impressions.

Only graphical methods of solving the problems, after the measurement of a crystal, are given, and the mathematical solutions are left to the more advanced courses.

In Part II, a knowledge of general chemistry is presupposed. Here some two hundred and twenty-five mineral species are included in the general descriptions, embracing the common rock-forming and ore minerals. Their crystallization, optical properties, decomposition products, genesis, occurrence, uses, and synthesis are included in the short description of most of the species.

The determinative tables and chemical tests used in the blowpipe table for the identification of the elements are included in Part III. This table includes all minerals with the exception of some very rare species found only in one locality, and in many cases includes even these. It therefore serves the purpose of placing before the

student a nearly complete list of the mineral species with their chemical formula, hardness, color, crystallization, and specific gravity. The table has been arranged after years of experience in teaching blowpipe analysis, and only those tests are employed and described which are quite easily manipulated, and wherever possible the dry or blowpipe tests are given the preference. In its scheme it is modeled after Brush and Cornwall's determinative table.

The table for the determination of the common minerals by use of their physical properties includes about one hundred and fifty species, and in connection with the short descriptions of these species given in Part II, makes their identification a simple matter.

Table I includes about fifty species of the rock-forming minerals arranged for their identification in rock sections under the microscope.

The illustrations, with the exception of two, have been drawn by the author, and the photographs reproduced are of specimens in the collection of Princeton University.

For advice and assistance in this work my sincere thanks are due to many of my colleagues, but particularly to my esteemed friend and professor, Henry B. Cornwall.

ALEXANDER HAMILTON PHILLIPS.

PRINCETON, NEW JERSEY,
September, 1912.

CONTENTS

PART I

CRYSTALLOGRAPHY

CHAPTER	PAGE
I. INTRODUCTION	1
II. DRAWING OF CRYSTALS	31
III. ISOMETRIC SYSTEM	47
IV. TETRAGONAL SYSTEM	65
V. HEXAGONAL SYSTEM	84
VI. ORTHORHOMBIC, MONOCLINIC, AND TRICLINIC SYSTEMS	113
VII. RELATION OF INDIVIDUAL CRYSTALS	134
VIII. ON THE MEASUREMENT OF CRYSTALS AND THE USE OF THE GONIOMETER	149
IX. OPTICAL PROPERTIES OF CRYSTALS	160

PART II

DESCRIPTIVE MINERALOGY

I. THE RELATION OF MINERALS TO THE ELEMENTS	219
II. THE ORIGIN OF MINERALS	237
III. PHYSICAL PROPERTIES	256
IV. THE NATIVE ELEMENTS	281
V. SULPHIDES, ARSENIDES, ANTIMONIDES	294
VI. SULPHO COMPOUNDS	320
VII. HALOID COMPOUNDS	327
VIII. OXIDES, INCLUDING THE ALUMINITES, FERRITES, AND CHRO- MITES	337
IX. CARBONATES	379
X. SILICATES AND TITANATES	403
XI. COLUMBATES, PHOSPHATES, VANADATES, INCLUDING THE NITRATES, BORATES, AND URANATES	507
XII. SULPHATES, CHROMATES, TUNGSTATES, AND MOLYBDATES	527

PART III

DETERMINATIVE MINERALOGY

CHAPTER		PAGE
I.	DESCRIPTION OF THE INSTRUMENTS, REAGENTS, AND CHEMICAL TESTS USED IN THE BLOWPIPE TABLE FOR THE IDENTIFICATION OF THE MINERAL SPECIES	546
II.	TABLE FOR THE DETERMINATION OF THE MORE COMMON MINERALS BY THE USE OF THEIR PHYSICAL PROPERTIES	595
III.	TABLE FOR THE DETERMINATION OF THE PRINCIPAL ROCK-FORMING MINERALS IN SECTIONS	609
IV.	TABLE FOR THE DETERMINATIONS OF MINERALS BY THEIR CHEMICAL TESTS	617

MINERALOGY

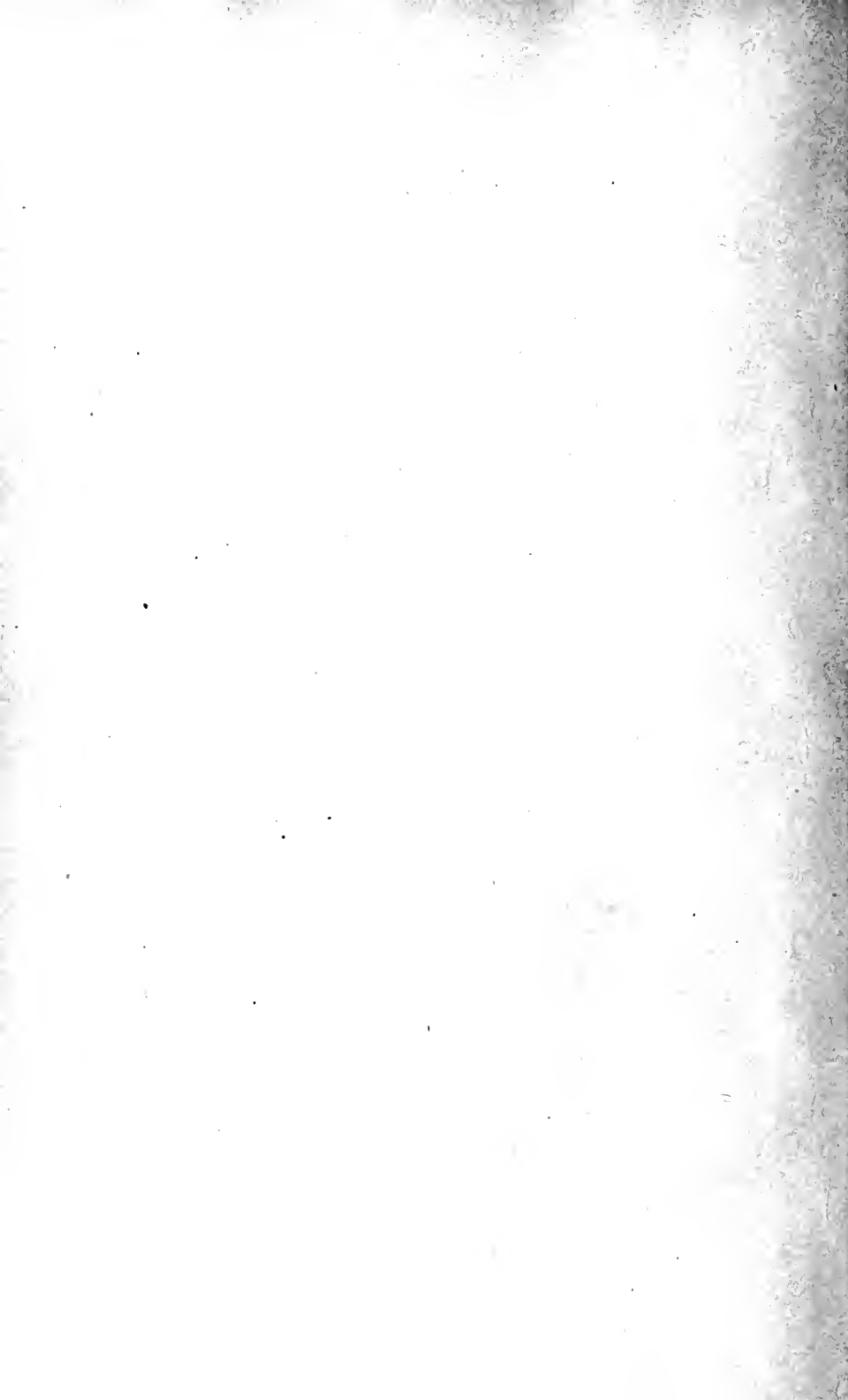

MINERALOGY

CHAPTER I

CRYSTALLOGRAPHY

THE solid, liquid, and gaseous states of matter depend upon temperature and pressure. It is possible to cause a solid to pass to the liquid state by raising the temperature. At 0° C. water passes from the solid ice to the liquid water; 0° C. is the fusing point, or the temperature at which the solid passes over to the liquid water. If the temperature is increased until 100° C. is reached, water passes to the gaseous state—steam. The temperature at which the vapor passes off freely and where there is no further rise in the temperature of the body of the liquid is known as the boiling point. The fusing point and the boiling point are fixed temperatures for pure chemical compounds. Upon decreasing the temperature and increasing the pressure sufficiently all substances become solid. If the solids formed by a slow transition from liquids or gases are examined, it will be found that the larger number are bounded, in part at least, by smooth plane faces. When arsenious oxide is heated it volatilizes; the vapors upon contact with a cold surface condense, forming a white coating; on examination with a lens, this white coat is found to be composed of small particles bounded by eight triangular faces, Fig. 1. Each individual is a crystal of arsenious oxide. All polyhedra formed by substances when passing to the solid state are crystals.

It has been the conception of scientists, since the time of Dalton, that the fundamental unit of matter was the atom; that the number of kinds of atoms is limited, and that each kind possesses distinct properties separating it from all others, thus forming a simple substance, an element. While the number of different kinds of atoms is small, all objects and compounds of nature are possible by the combination of this small number of elements.

The number of atoms joining to form the unit or molecule of a compound can, by the law of Avogadro, be determined for all

volatile and dissolved substances. The number of hydrogen atoms combining with one atom of oxygen to form one molecule of water, is two; yielding the chemical expression H_2O for water. The chemical molecule is the smallest particle of a compound which



FIG. 1. — Octahedral Crystals of Arsenious Oxide, As_2O_3 .

can exist and still retain the physical properties of the compound. In the attempt to divide the chemical molecule of water, the atoms being indivisible, the one atom of oxygen must be separated from the two atoms of hydrogen, resulting in two substances, oxygen and hydrogen, neither of which possesses the properties of water.

There is no method of demonstrating whether the solid or crystalline molecule and the chemical molecule are identical. Since a number of atoms combine to form a chemical unit, it is also probable that a number of chemical units combine to form a crystalline unit or molecule. The study of the structure of crystals indicates that there is such a combination, but as to the exact relation of the one to the other, all that can be said is that the crystalline unit may be expressed by a multiple of the chemical molecule; in case of ice, $n(H_2O)$. The light of recent research would indicate that n is a small number, and the crystal unit is not the complex grouping of a large number of chemical molecules it was formerly thought to be.

The forces surrounding the molecule in a solid may radiate equally in every direction as if from a center, such a group of molecules would form an **amorphous** solid; or again, the lines of force may vary with the direction, when the solid would be **crystalline**. The physical properties, as elasticity, hardness, transmission of light, conductivity of heat, will be the same for all directions in amorphous solids. Glass, which is an amorphous substance, will expand equally in all directions upon heating. If a sphere of glass is heated and measured at various temperatures it will at each measuring be a true sphere; while all its diameters have increased in length with the rise in temperature, they all have increased by exactly the same amount. Amorphous solids

possess no regular outward form bounded by plane faces, but are irregular, globular, or rounded masses, Fig. 2. The physical properties of crystalline solids are the same along parallel directions, but not necessarily so along directions that are not parallel. The direc-



FIG. 2. — Hyalite from Waltseh, Bohemia: An Amorphous Mineral.

tional variation of the physical properties is a primary character of crystals, and all compounds to be crystalline must possess it; as will be shown later, this is caused by the regular arrangement of the molecules, assumed as the substance passes from the liquid or gaseous state to the solid.

Crystals are generally bounded by plane faces, but the smallest fragment of a crystal will possess this directional quality of its properties, and by it may be identified as crystalline. The tendency to form crystals, or the crystalline force, varies with the substance, being very strong in quartz or calcite, which are almost never found but in the crystalline condition; while in others, as chrysocolla and turquoise,¹ upon which crystal faces have never been

¹ Turquoise has lately been found in crystals.

observed, but in which the physical properties are directional, the crystalline force may be considered as being very feeble. The crystalline force will vary not only with the substance, but will differ with the direction in the same substance. When the molecules pass to the solid state, from a condition in which they are free to move, and become fixed under the influences of the crystalline force, it is reasonable to suppose that in the direction in which the crystalline force has the strongest attraction the molecules will be packed closer together. In the direction in which the force is

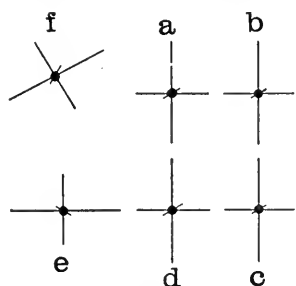

FIG. 3.

feeble they will be farther apart. The forces influencing and surrounding each molecule are exactly the same as the forces influencing and surrounding every other molecule; there is no singular molecule. The distance from any molecule to its nearest neighbor in the same direction will be exactly equal in all. In Fig. 3, a, b, c, d are in complete crystalline position, while e must be revolved 90° , and f must be

both revolved and translated to reach a crystalline position in regard to a, b, c, and d.

The whole will form a **regular molecular network**, or **point-system**, in which each molecule holds an exact position, just as each individual man in a marching regiment must be in his exact position, holding a fixed relation to those surrounding him; and further, if our attention is directed to the complete formation, it will be seen that as a consequence of the orderly position of each man, the whole is bounded by straight lines. If it were possible to place one regiment on top of another, the straight lines would then become planes, and the solid thus formed would be bounded by plane faces; in a similar way crystals are bounded by **plane faces**.

The smooth plane faces bounding a crystal are its most striking external character. It must always be remembered that they are only reflections of the internal orderly arrangement of the molecules. If the crystalline molecules are identical with, or a small multiple of, the chemical molecule, then the crystalline units may be considered infinitely small, as regards any power we may possess to distinguish them when packed together, forming crystal faces. All artificially polished surfaces fall far short of the smooth-

ness and perfection of the natural polish of crystal faces and cleavage surfaces.

If a crystalline molecule is placed at each corner of a cube, the distance between each molecule will be measured by the length of the edge, Fig. 4 a. The cube may be considered an elementary form or unit of a homogeneous point-system which may be built up, as in Fig. 5.

If the cubical unit is lengthened in one direction, it will now possess edges of two different values, Fig. 4 b. This unit when packed together so as to fill space will produce a regular point-system of another type, Fig. 6. The second unit may now be broadened, when it will possess edges of three different values, Fig. 4 c, and when packed together will fill space, producing a point system of still another type. There are fourteen such elementary units, which when packed together will fulfill the crystalline requirements of completely filling space, and place each molecule of

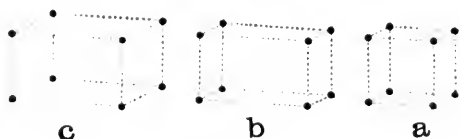

FIG. 4.

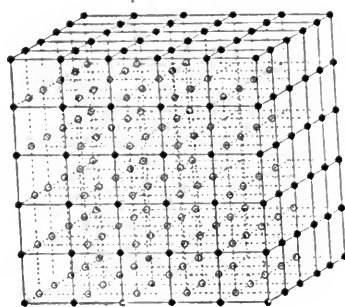

FIG. 5.

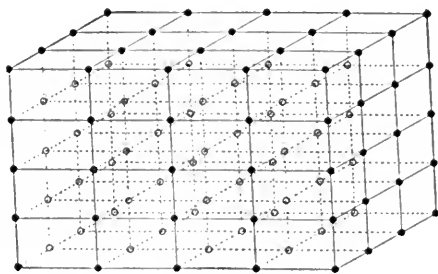

FIG. 6.

the system in such a position that its surroundings shall be exactly the same as the conditions surrounding every other molecule.

The shape of the fourteen elementary units must in no way be considered to represent the shape of the molecule, as the space between molecules is far greater than the diameter of the molecule, and there is no method by means of which the shape of a molecule can be determined. These dimensions of space may be considered

as representing the sphere of action, or the sphere of vibration, or oscillation, of each molecule.

While the number of elementary point-systems is limited to 14, the number of complex point-systems must be much extended in order to reach a satisfactory explanation of the symmetry of those crystalline types in each system lower than the normal. These lower types of symmetry may be produced by a combination of the elementary point-systems: 1. As if one were pushed within the other, there will be, in such a case, two sets of molecules, one occupying a position in respect to the other, as if translated along a definite direction. 2. By the rotation of one in regard to the other. 3. By both rotation and translation. The number of point-systems made possible by these methods will reach 230. It still remains true, however, that in regard to their symmetry they will all be included in the 32 possible types of crystals.

Definition of a crystal. — A crystal is a homogeneous chemical compound bounded by plane faces, and its physical properties are alike along parallel directions.

Crystal growth. — If growth is considered to be an increase of size only, then crystals may be said to grow. This crystalline growth must not be confounded with organic growth, which is a development. The tissues in an organism increase in complexity; the unit in organic growth is the cell, which increases by division. One cell producing two, these in turn increase in size by an assimilation of material within the cell wall. Organic growth takes place from within, while crystalline growth goes forward by the attachment of crystalline molecules from without the point-system, extending the individual crystal laterally in every direction by the thickness of each molecular sheet added. One crystal therefore cannot be an embryo of another, as when a sufficient number of molecules have collected to form a unit of the point-system, and are fixed in the required position, they will possess all the crystalline characters. Microscopic crystals, however small, are just as perfect in regard to their chemical and physical properties as a crystal a foot in diameter, the difference being a mere matter of mass or bulk.

Crystallization. — It has been shown that in the crystalline state of matter each molecule has a definite and fixed position relative to those surrounding it. In the liquid, gaseous, and dissolved states, every molecule is free to move, and in any direction, leaving out of account the so-called liquid crystals; and until their

discovery, crystals were always considered to be necessarily solids.

If it is wished to crystallize any substance, and thus obtain crystals of any compound for study, it will be necessary to bring the substance into one of those conditions of matter in which the molecules are free to move, and then to reverse the process under such conditions that the transition to the solid state will take place very slowly. Each molecule will be fixed upon the network with all equivalent lines of force parallel, providing always that the substance is capable of forming crystals. Several cases may arise:

1. The substance may be a gas; all gases, with the exception of helium, have been solidified by decreasing the temperature and increasing the pressure. Carbon dioxide, a gas at ordinary temperatures, becomes a liquid at -78.2° C.. Liquid carbon dioxide is sold in the market in iron tubes. At ordinary temperatures these tubes are subjected to a pressure of 60 atmospheres. If a small jet of the carbon dioxide be allowed to escape in a beaker, by the sudden expansion and vaporization a large amount of heat is absorbed and the temperature of the remainder caught in the beaker falls below the freezing point, and snowlike crystals of solid carbon dioxide are formed.
2. The substance to be crystallized may be a liquid; leaving out of consideration supercooling, if the temperature of a liquid is decreased, at a definite temperature, the freezing point, crystalline nuclei will appear. From these as centers crystallization will take place until all the liquid has become solid. These centers of crystallization may be seen on the surface of any pool of water just as ice begins to form.
3. The substance to be crystallized is a solid; substances in this class will fall under three divisions: *A.* Solids which when heated volatilize without fusion. If the metal arsenic is heated, it volatilizes without fusion; on resolidification, out of contact with oxygen of the air, the metal will be crystalline. Solids formed in this way are known as **sublimates**. *B.* When heated, the substance fuses without chemical change. Such metals as silver, copper, lead, in fact most of the elements, may be crystallized in this way. The crystals of the igneous rocks, as the feldspars, olivine, augite, etc., have been formed from a fusion; only here there has been a segregation, or a separation of the various kinds of molecules at the same time. *C.* The substance is either infusible, or is decomposed when heated. When a solid is dissolved in a liquid, its molecules pass off from the surface and

move as free as those of a gas. Just as water evaporates in the air, the solid may be said to evaporate in the liquid; this continues until the liquid is no longer able to hold more of the solid, and equilibrium between the liquid, solid, and the dissolved substance is established, when the solution is said to be saturated. This condition will remain as long as the temperature, pressure, and solubility remain constant. Crystals of copper sulphate may be obtained from a saturated solution by cooling the solution. Salts with few exceptions are more soluble the higher the temperature. Again, crystals may be obtained from a saturated solution by decreasing the amount of the solvent; let the solution slowly evaporate, both processes will be combined, as the slow evaporation will cool the solution; counteracting this decrease of temperature is the heat of crystallization, for where crystals are forming there heat is being liberated. Perfect crystals may be secured by suspending a small crystal on a thread in the slowly evaporating saturated solution, at the same time guarding against any sudden change in temperature. It is also well to mechanically revolve the growing crystal to insure its being surrounded by solution of the same concentration, when the deposition will be uniform.

Crystals may also be formed from solution by a decrease of the solubility, produced, as in precipitation, by the addition of some reagent in which the dissolved salt is less soluble, or as in the salting out process by the addition of a common ion. All sulphates are insoluble in alcohol; if alcohol is poured carefully over the surface of the copper sulphate solution so as to lie as a layer covering the surface, it will mix slowly with the solution and the solubility of the sulphate will be decreased gradually, producing perfect little crystals of copper sulphate.

A large number of chemical compounds, especially the more insoluble salts, may be prepared in crystalline form by chemical precipitation. If to a neutral solution of calcium chloride a solution of sodium carbonate is added, a white, flocculent, amorphous precipitate of calcium carbonate is produced which on standing becomes crystalline. In the first rapid separation the more unstable amorphous solid is formed, which becomes crystalline, not by the rearrangement of the molecules in the solid, but by a slow transfer of molecules from the unstable amorphous solid to the crystalline nuclei by resolution, the crystalline form being the more stable.

The methods mentioned are the more important; there are modifications and combinations of these which are applicable to con-

crete cases. The metals which are easily reduced electrolytically are deposited on the ~~anode~~^{cathode} in crystalline form; these are, however, always distorted and irregular through structural anomalies. With a very weak current good crystals of copper, silver, or lead may be obtained, Fig. 7. Crystallization is a method employed in the separation and purification of chemical compounds, and especially is this so in the commercial field, where efficiency and cheapness are factors of such great importance. Granulated sugar, one of the few chemical compounds produced in enormous quantities in almost absolute purity, is separated by crystallization.



FIG. 7.—Crystals of Silver obtained by Electrolysis.

The purity of a crystalline compound will depend upon the rate of separation, the viscosity of the mother liquid, and its solubility. If perfect crystals are sought, great care must be exercised in the control of the growth of the crystals, the deposition of molecules must go on very slowly. If there is a sudden decrease in temperature of the solution, a heavy shower of molecules upon the forming crystals results; they will increase more rapidly along the edges at the expense of the center of the faces, producing **skeleton** crystals. The hollow faces may ultimately build out, leaving interior cavities filled with mother liquid. All foreign matter incorporated in the body of a crystal, whether of liquid, gas, or solid, is known as an **inclusion**. The purity of a crystalline salt is inversely proportional to the rapidity of formation and to the size of the crystals. When a pure salt is required, it is best to let the crystals form slowly and remove them from the mother liquid while still small.

Constancy of angles.—The size of a crystal and the general shape will depend to a large extent upon the conditions prevailing at the time of its formation; the question may be asked, if the size and shape of a crystal is variable, is there anything that is constant upon which the science of crystallography may be based? Nicolaus Steno, a Danish geologist, in 1669, while cutting sections of quartz crystals, noticed that, however variable the outline of the sections may be, due to irregularities of growth and to the difference in size of faces, whenever the sections from the various crystals were cut in a parallel direction the corresponding angles were always equal. The ordinary quartz crystal is terminated by six

triangular faces of equal size, Fig. 8, or by three large faces and three smaller faces, as **b**, or the point may be stretched out to a straight line, as in **c**. If a section be cut directly through the apex of a



FIG. 8. — Distorted Crystals of Quartz, Herkimer County, New York.

quartz crystal at right angles to the opposite faces, the outline of the section in every case will be different, but the corresponding angles, Fig. 9, **a**, or **b**, are always equal.

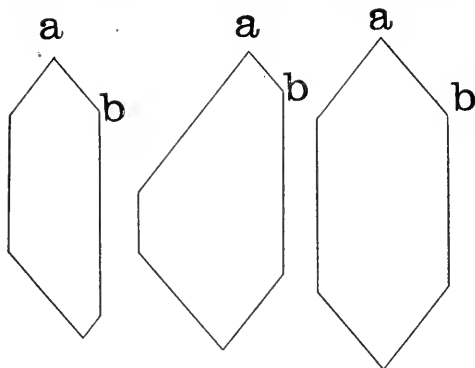

FIG. 9. — Parallel Sections of Quartz Crystals.

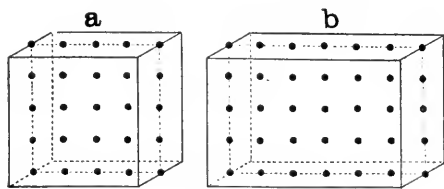

FIG. 10.

This law may be stated as follows: *the dihedral solid angle between similar faces of crystals of the same substance is constant, provided always that the substance is chemically pure and that the angle is measured at the same temperature.*

Crystal angles are as characteristic of chemically pure compounds as their chemical or physical properties; not only may they be identified by the angles, but they are an index to the purity of compounds.

The constancy of the interfacial angle is a direct result of the regular molecular network or point-system. In Fig. 10a the round dots represent one sheet of molecules of the point-

system; should the crystal stop growing after five sheets were laid down it can be seen that the cross section is a square, and the solid formed, a cube. If for any reason growth is irregular and molecules are laid on faster at one end, Fig. 10 b, the cross section is now no longer a square, but a parallelogram; the solid is no longer a cube, but is elongated in one direction. All angles are right angles and cannot vary as long as the molecules are laid on in this order. We cannot imagine the angles varying from a right angle, any more than it would be possible for a cube to possess angles not right angles.

In measuring and comparing angles between similar faces, those faces are considered similar which cut the point-system in the same direction or inclination. The six faces of the cube are, in regard to the point-system, interchangeable. The configuration of the molecules in the plane of each face is the same, therefore the physical properties of each face will be the same and the angles between them will be the same. This is also true for the elongated cube, for the addition of molecules on one side will distort the form, but cannot possibly change the arrangement of those molecules already laid down, upon which the value of the interfacial angles depends. In all similar faces the molecules are the same distance apart in any given direction: they will lie parallel or equally inclined to the same lines of force; they will show the same luster, polish, and hardness; they are equally soluble and yield the same corrosion figures; they will expand with an increase of temperature equally along parallel directions. The distribution of the magnetic force and electric charge will be alike; in fact, all physical properties of whatever description will be exactly the same, and must be considered in the identification of similar faces.

The goniometer. — The exactness of the interfacial

angle is so great that the accuracy of the angles of chemically pure crystals far surpasses the capabilities of any instrument we may

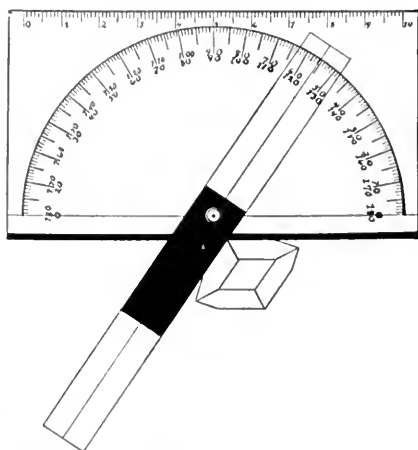

FIG. 11. — The Penfield Card Goniometer.

construct, however delicate, to measure them. The more time and patience used in both the construction of the instrument and in measuring the angle, just so much nearer is the result to the theoretical angle of the crystal. The instrument used for measuring angles of crystals was invented by Carangeot in 1783. It is to Rome de l'Isle that the science owes the development of the crystal model; he modeled some 500 forms. It was to facilitate this work that Carangeot, his assistant, devised the contact goniometer. This form of instrument is still in use for the rough measurement of large crystals and for crystals with dull faces.

Figure 11 represents the Penfield model, a very inexpensive, but convenient form, useful also as a protractor in laying out angles and measurements in crystal drawings.

All contact goniometers are constructed upon the same principles, the simplicity of which is such that it needs no explanation other than the figure given. The angle is read directly from the scale. In 1809 Wollaston constructed the reflecting goniometer, realizing the need of a more accurate instrument in his work on isomorphism. The principle of this form is illustrated in Fig. 12, where the ray of light la is reflected from the face d to the eye at e , when a reading of a scale attached to the instrument is taken. The crystal is now revolved around the edge a , formed by the intersection of the two faces, the angle between which it is wished to measure. When the ray of light is again reflected to the eye at e , the crystal will have

assumed the dotted position; another reading is taken and the difference between the two readings will give the angle, rar' , the

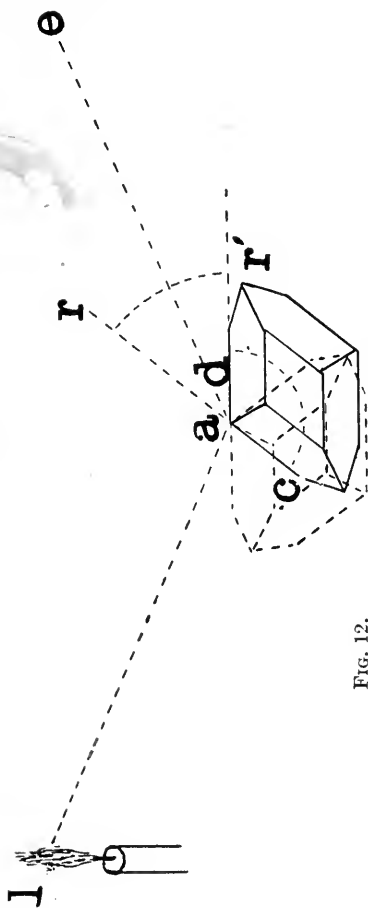

FIG. 12.

supplement of the interfacial angle $r'ac$; for details of measurement see page 149.

Symmetry. — All nature in its building follows rules of symmetry; worms possess many segments, one of which is a repetition of the conditions found in that adjacent. The leaves of plants are placed on the stem following definite rules of repetition; and in vertebrates the right side is a mirror image of the left, following a bilateral plan. These rules in organic nature are only partially adhered to and are not followed with that mathematical exactness which the constancy of the interfacial angles in crystals demands. **Symmetry** may be defined as *the repetition of condition following definite rules*. The rules of symmetry in crystals apply not only to the repetition of faces, which determine the outward form, but to the internal molecular arrangement and all the physical properties as well.

In crystals the three rules of symmetry are: (1) symmetry in regard to a plane; (2) symmetry in regard to an axis; (3) symmetry in regard to a center.

A solid is said to possess a plane of symmetry when that plane divides the solid in two halves, in such a manner that all the conditions on one side are faithfully repeated on the other side of the plane, as in a mirror image; or if from any point c , Fig. 13, on one side of the plane ab , a perpendicular be drawn to the plane and extended in a straight line an equal distance on the opposite side of the plane, if the plane is a plane of symmetry, there will be a point c at its extremity, the conditions surrounding which will be exactly the same as the conditions surrounding the original point, and the solid is said to be symmetrical in respect to a plane.

A plane mirror is the best example of a plane of symmetry, as on looking in the mirror every object in front is apparently repeated in the mirror. Symmetry in regard to a plane is the symmetry of reflection.

If the similar parts of a solid are repeated more than once in

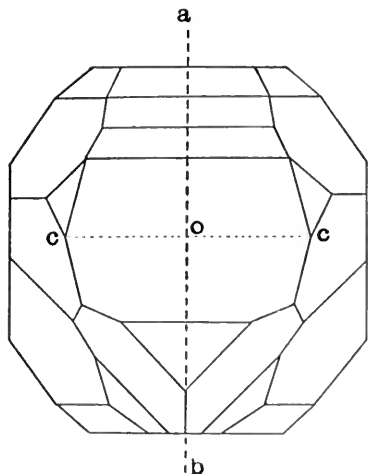

FIG. 13. — Plane of Symmetry.

360° by a revolution of the solid around an axis, then it is said to be symmetrical in respect to an axis, or to possess an axis of symmetry. In Fig. 14, if from any point *a*, in the solid, a line be drawn perpendicular to the axis at *o*, when revolved about the axis *o* as a center the point *a* will describe a circle; if on this circle it meet a point *a'*, the conditions surrounding which are exactly the same as those surrounding the point *a*, then *o* is an axis of symmetry. The crystal will, in this instance, after a rotation of 180° become congruent, or will appear as if it had not been revolved. Symmetry in respect to an axis is the symmetry of revolution.

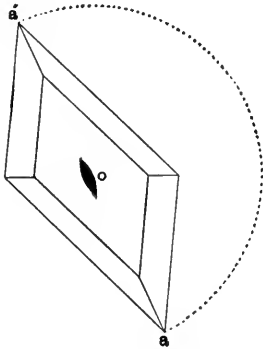

FIG. 14.—A Digonal Axis of Symmetry : Gypsum.

An axis of symmetry is a **digonal axis**, if the crystal becomes congruent after a revolution of 180°. Such an axis is represented by the conventional sign as at *o*, Fig. 14. A **didigonal axis** is a digonal axis at the intersection of two planes of symmetry.

If the crystal becomes congruent after a revolution of 120°, the axis is a **trigonal axis**, represented as at *o*, Fig. 15. A **ditrigonal axis** is a trigonal axis at the intersection of three planes of symmetry.

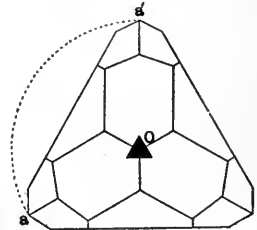

FIG. 15.—Trigonal Axis of Symmetry : Tourmaline.

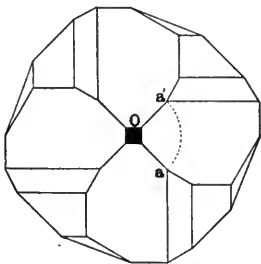

FIG. 16.—Tetragonal Axis of Symmetry : Schelelite.

If it becomes congruent every 90°, the axis is a **tetragonal axis** and is represented as at *o*, Fig. 16. A **ditetragonal axis** is a tetragonal axis at the intersection of four planes of symmetry.

If it becomes congruent every 60° it is a **hexagonal axis** and is represented as at *o*, Fig. 17. A **dihexagonal axis** is a hexagonal axis at the intersection of six planes of symmetry. The above four axes are all the possible axes of direct rotation to occur in crystals.

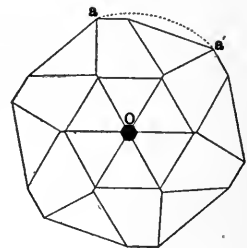

FIG. 17.—Hexagonal Axis of Symmetry : Apatite.

Alternating axis. — In Fig. 18, if any point a is revolved around an axis oo' , 90° , to a position a' , then reflected over the plane bb' , to a position a'' , becoming congruent, and so on four times in one complete revolution, then oo' is a tetragonal alternating axis. If the crystal becomes congruent by rotation and reflection six times in 360° , then the axis is a hexagonal alternating axis; in all such cases the plane of reflection is not a plane of symmetry in the crystal. Diagonal or trigonal alternating axes are not possible.

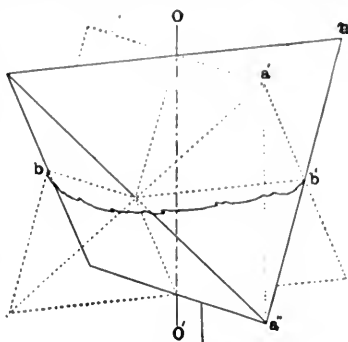

FIG. 18. — Axis of Alternating Symmetry: Chalcopyrite.

Center of symmetry. — In Fig. 19, if from any point a , a line be drawn to o , the center, and extended an equal distance in the same direction beyond the center, when o is a center of symmetry it will meet a point a' , similarly located. The face abc will be repeated at $a'b'c'$, and all crystals having a center of symmetry will be bounded by pairs of parallel faces.

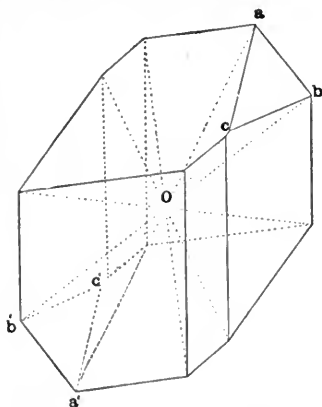

FIG. 19. — Axinite, showing a Center of Symmetry.

Crystallographical axes. — In order that crystal faces may be located in space, their relations mathematically calculated, their angles measured, at the same time furnishing a concise, accurate, and convenient form of expressing all their relations, crystal faces are referred to imaginary lines drawn through

the crystal and known as the **crystallographical axes**. These axes are, as in analytical geometry, generally three (in one system four) intersecting at a common point within the crystal, the origin. The length and inclination of the axes will vary with the system to be represented. The direction through the crystal is always so chosen as to give the simplest relation possible, which is determined by the symmetry that is present. Where there are axes of symmetry present, the axes of highest symmetry are chosen as crystallographical axes. Where axes of symmetry are absent the

crystallographical axes are chosen so as to pass through the crystal parallel to the edges formed by the intersection of three faces, simply related and occurring the more often on the individual crystals. By this method the axes are so placed as to be parallel to rows of molecules in the point-system. This will be understood by a consideration of Fig. 6, page 5.

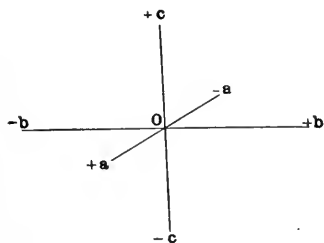

FIG. 20. — Crystallographical Axes.

In referring to the axes, the vertical axis is always denoted by the letter *c*, Fig. 20. The axis running from right to left in the plane of the paper is denoted by the letter *b*; the axis running back and front through the paper is the *a* axis. If in any case the axes are equal and interchangeable, the equal axes are designated by the same letter, as *a*. If planes are passed through the origin, so that each plane shall contain two axes, Fig. 21, there will be three such axial planes, or principal sections, intersecting at a common point *o*, which will divide space distributed around *o* into eight octants, in any one of which

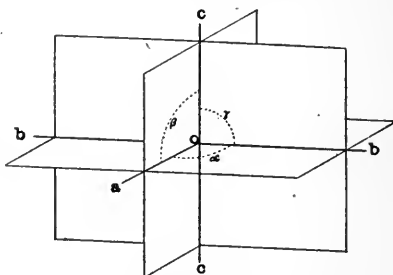

FIG. 21. — Axial Planes and Angles.

it will be possible for a crystal face to occur. Each octant is distinguished by measuring in a + or - direction on the axes from the origin *o*, as indicated in Fig. 20. The upper, front right octant will be + *a*, + *b*, + *c*; the lower, back, left octant will be - *a*, - *b*, - *c*; the minus sign is the only one written. When the angle between the axes are not right angles, they are distinguished as in Fig. 21, $aob = \alpha$, $aoc = \beta$, $boc = \gamma$.

Crystal systems. — When referred to their crystallographical axes, crystals fall into six systems, here defined in terms of their axes.

I. **Isometric.** — Includes all those crystals which may be referred to three equal and interchangeable axes at right angles. All three axes are designated by the letter *a*.

II. **Tetragonal.** — Includes all those crystals which may be referred to three axes, all at right angles, two of which, the lateral

axes, are interchangeable and equal. The axes are designated, $a : a : c$.

III. **Hexagonal.** — Includes all those crystals which may be referred to four axes, three of which are equal and interchangeable, being in the same plane at an angle of 60° with each other; all are at 90° to the fourth, or c axis. The axes are designated, $a_1 : a_2 : a_3 : c$.

IV. **Orthorhombic.** — Includes all those crystals which may be referred to three unequal axes, all at right angles. The axes are designated, $\bar{a} : \bar{b} : \bar{c}$.

V. **Monoclinic.** — Includes all those crystals which may be referred to three axes, all unequal; two of these, the lateral axes, are at right angles to each other. One of these is at right angles to the third, or c , axis; the other is inclined. The axes are designated, $\bar{a} : \bar{b} : \bar{c}$.

VI. **Triclinic.** — Includes all those crystals which may be referred to three axes, all unequal and all inclined. They are designated, $\bar{a} : \bar{b} : \bar{c}$.

Some are accustomed to add to these six systems a seventh system, the rhombohedral or trigonal system, referred to axes parallel to the edges of the rhombohedron. The forms included in this system are very closely related to the hexagonal system, and can be included in that system equally as well.

Parameters. — The distance from the origin at which any plane, or face, cuts a crystallographical axis, Fig. 22, as ob' , is the intercept of that plane $a'b'c'$ on the axis b . This intercept expressed in terms of the unit on that axis, and written as a coefficient of the symbol standing for or representing the axis, is the parameter of the plane on the axis. If ob is

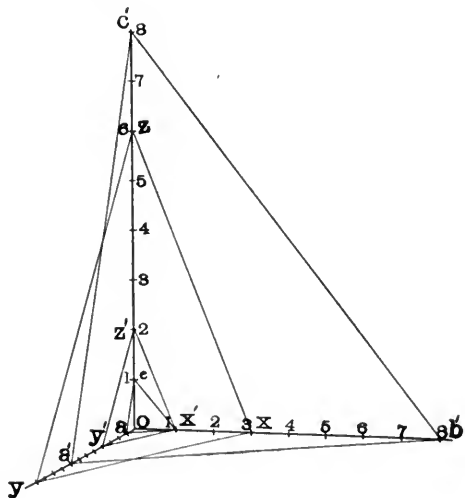

FIG. 22. — Axial Intercepts.

the unit on the axis b , then $\frac{ob'}{ob}$, in this case $8, 8b$, is the parameter

of the plane $a'b'c'$ on the axis b . In the same manner parameters are derived for the axes a and c . In general the parameters of any plane xyz would be

$$\frac{oy}{oa}a : \frac{ox}{ob}b : \frac{oz}{oc}c;$$

in this case $12a : 3b : 6c$ are the parameters. They definitely fix the inclination to the axes. The actual length of the intercepts varies with the size of the crystal and is unimportant. It is the relative length, one to the other, or their ratio, which determines the inclination of the faces, and fixes the interfacial angles. The plane abc , intersecting all three axes at unit lengths from the origin, is designated by $a : b : c$, and is crystallographically identical with the plane $a'b'c'$ ($8a : 8b : 8c$); multiplying all the coefficients by 8 simply moves the plane out from the origin parallel to its former position. It still stands with the same inclination to the axes and will intersect all three planes with the same angle as before; the crystal is only increased in size. It is the custom to simplify the parameters by moving any plane back or forward on the axes until the intercept on one axis is unity. If the parameters $12a : 3b : 6c$ of the plane xyz are divided by 3, they become $4a : b : 2c$; the coefficient of b is reduced to unity. This is the same as moving it to the position $x'y'z'$, cutting the axis b at unity, parallel to the original position. It represents the same crystal in either position. When a plane is parallel to an axis, it intercepts that axis at infinity, and is expressed ∞a ; when a set of parameters contain two infinities, the plane is moved until the remaining intercept is unity and the parameters are written $\infty a : \infty b : c$. This system of denoting crystal faces was one of the earliest methods devised, and is known as the parameter system of Weiss; it has the advantage of simplicity and directness in expressing the relation of intercepts which enables one to see at once the relation of the plane to the axes. In the drawing of crystals it is practically necessary to reduce all other symbols to their equivalents in Weiss's system, in order to lay out the axial intercepts; for this reason it is well to become thoroughly accustomed to the notation of Weiss in the very beginning.

Indices of Miller. — There are a number of other notations which are in use, the most important of which is Miller's system of indices, now generally used in all works on crystallography. The most general form, or the indices of any plane, are written hkl ; the three axes always maintain their usual order. The indices

may be derived from the parameters of Weiss, by dividing the parameters by their least common multiple and reducing the fraction to the lowest terms; now each coefficient will stand as a fraction in which the numerator is one. Let it be required to convert $2a : 3b : 4c$ to indices. Dividing by 12, we have $\frac{2}{12}a : \frac{3}{12}b : \frac{4}{12}c$, reducing to the lowest terms, $\frac{1}{6}a : \frac{1}{4}b : \frac{1}{3}c$, the three denominators are then written 643 (read six, four, three) as the indices. The same operation may be expressed thus: the reciprocals of the parameters are written in the order of the axes, cleared of fractions, reduced to their simplest form, and then written as the indices. Taking the same parameters as before, $2a : 3b : 4c$, the reciprocals are $\frac{1}{2}, \frac{1}{3}, \frac{1}{4}$; cleared of fractions by multiplying by 12 and reducing to simplest form, the indices 643 are obtained as before. The reverse of this is necessary in order to obtain the parameters from the indices; it is almost unnecessary to point out that the indices are always whole numbers and cannot be fractions. When ∞ appears in the parameters its reciprocal 0 takes its place in the indices. The minus direction on the axes is indicated by writing the sign above the figure, as $\bar{1}\bar{2}3$.

Examples of equivalent planes :

PARAMETERS OF WEISS	INDICES OF MILLER
$a : b : c$	111
$2a : \infty b : c$	102
$-a : 2b : -3c$	$\bar{6}3\bar{2}$
$\infty a : -b : \infty c$	0 $\bar{1}$ 0
$\frac{3}{2}a : b : 3c$	231
$\frac{1}{2}a : b : \frac{3}{4}c$	634
$-a : a : \infty a$	$\bar{1}$ 10

Rationality of the indices. — All crystals are formed by a regular deposition of sheets of molecules. The relation of these sheets to the point-system of which they form a part will determine the faces and angles of the crystal, as well as the intercepts on the crystallographical axes. Each intercept is determined by a definite number of whole molecules, for it is impossible to divide a molecule and have it possess the same properties; when divided it becomes a substance of a different character, belonging possibly to a different crystal system. Every face possible on a crystal is determined by a whole number of molecules which determine the relative size of the intercepts. The ratio of the intercepts of any or all planes possible on a crystal to any other plane on the crystal must be a rational

number. Both the parameters and the indices can be expressed in whole numbers, 0, or ∞ . It has been the experience in the past that, with few exceptions, these numbers are small, rarely larger than 9. In Fig. 23, the sheet of molecules lying in the axial plane *cob* is represented. Possible planes intersecting this sheet at right angles are represented by *aa*, *dd*, *ee*, etc., each of which intersects

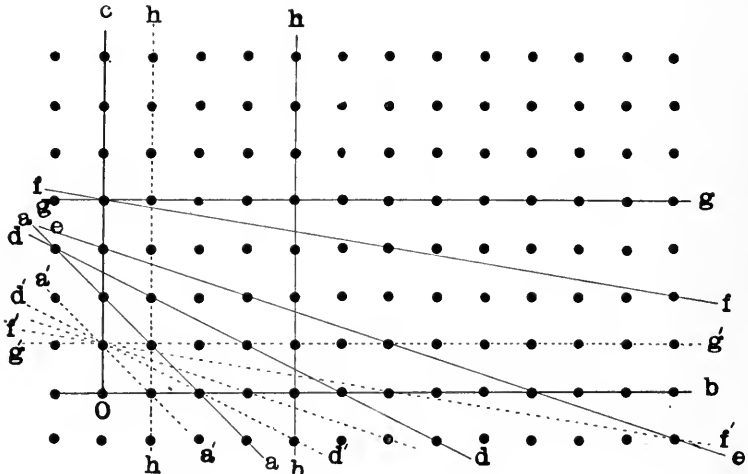

FIG. 23.

the axis *b* at greater distances; let all these possible faces be moved up towards *o* until they intersect the axis *c* at unit distance, or the diameter of one molecule; they will now be represented by the dotted lines *a'a'*, *d'd'*, *e'e'*, etc. The ratio of the intercepts of the plane *a'a'* on the axes *c* and *b* is as 1 : 1; of *d'd'*, 1 : 2; of *e'e'*, 1 : 3; of *f'f'*, 1 : 7; of *g'g'*, 1 : ∞ . Thus the parameters are all whole numbers and the ratios are rational quantities. Theoretically it would be possible for a face to occur with an intercept greater than any indicated, but actually they are very rarely observed.

The distance between neighboring molecules lying in the plane of any face will increase with the intercept, except when the plane becomes parallel to an axis. The molecules in the plane *aa* are much nearer each other than the molecules in the plane *ee*; molecules have the tendency to crowd together as closely as possible. It follows therefore that those faces will appear the more often on crystals in which the molecules are the nearest. In Fig. 23, the cube face *hh* and rhombic dodecahedron *aa* will occur the more often, as

the molecules are the nearest in the planes. They will also possess small intercepts and a simpler relation of their parameters.

Crystal forms. — When space is divided by the three axial planes into eight octants it is evident that one set of parameters may represent more than one face; in fact there will be eight planes, or one in each octant. The solid bounded by these eight faces is known as a crystal form; the symmetry of the type may not, however, require all the eight faces to be present. A **crystal form** may be defined as *the solid bounded by the combination of all those faces possible to be represented by one set of parameters irrespective of sign; and required by the symmetry of the type.* The combination of planes may inclose space or may not.

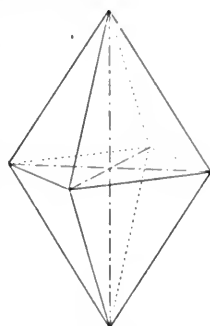

FIG. 24.

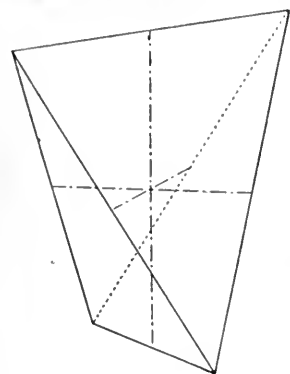

FIG. 25.

In Fig. 24, eight faces are shown, all of which are represented by the set of parameters, $a : b : c$, and the symmetry of the type requires all eight faces to be present; Fig. 25 represents four of the same faces, but producing an entirely different form, as the symmetry of the type requires only four of the eight faces to be present. When one face only is intended to be represented by a set of parameters, or indices, they are written without parenthesis 111; when the entire form is represented, they are written (111).

The number of faces possible on any crystal form may vary from 48, in the type which possesses the highest symmetry, to one face in the type which contains no symmetry. As at least four faces are required to inclose space, there are two classes of crystal forms, those that inclose space and are termed closed forms, Fig. 26, and those which do not inclose space, and are termed open forms, Fig. 27; theoretically the open forms extend to infinity on the open sides, unless terminated

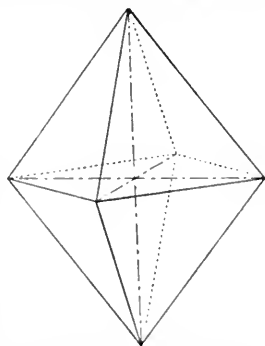

FIG. 26. — Unit Pyramid of Barite; a Closed Form.

by a combination with other forms. Combinations of open forms may inclose space. The number of faces occurring on any crystal form is very limited, but the number of faces possible on a crystal which is a combination of crystal forms is not limited and in some cases may be very large. The forms which may occur in combination on crystals are limited to those possible to be derived from the same point-system, and they will therefore have the same symmetry. From the symmetry of the type, forms

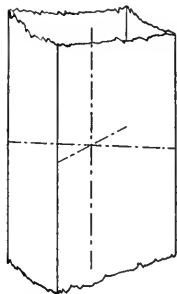

FIG. 27. — An Open Form.

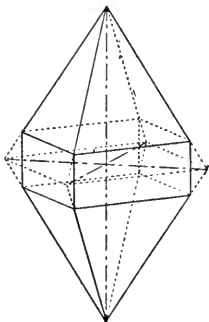

FIG. 28. — Combination of a Closed and Open Form.

in combination always bear the same relation to each other; Fig. 28 is a combination of the closed form of Fig. 26 and the open form of Fig. 27; here equivalent edges are cut by the prism, or the four edges of the pyramid are replaced by the prism faces. When the replacement is symmetrical, as in this case, the angles between the prism and the pyramid faces above and below are equal; the pyramid edges are said to be **truncated** by the faces of the prism. In the same way, corners of forms may be truncated by other forms and replaced not only by one face, but by a group of faces, Fig. 29. When the edge of one form is symmetrically replaced by two faces, it is said to be **beveled**, Fig. 30.

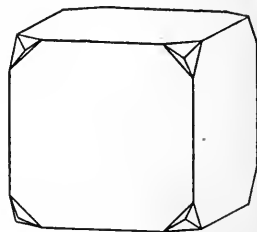

FIG. 29. — The Cube with the Corners replaced by the Tetragonal Trisectahedron.

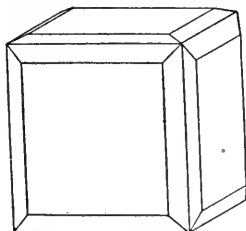

FIG. 30. — The Cube beveled by the Tetrahexahedron.

Zones. — The edge of a form may be replaced by a series of faces, the mutual intersections of which are all parallel to the edge replaced. Such a series of faces is termed a zone. The intersections of all faces possible in any one zone will be represented by possible edges on the crystal, all parallel to each other and parallel to an imaginary line drawn through the point of intersection of the crystal axes, termed the

zonal axis, Fig. 31. In the study of crystal faces it will be found that they all belong to a comparatively few zones. The intersection of any two faces on a crystal will determine the direction of a possible zonal axis. Faces belonging to the same zone must be so related that two of their intercepts will bear a constant relation, and their intersections with the axial plane in which these two intercepts are measured will be parallel lines. In Fig. 32 four faces belonging to the same zone are represented and extended to the axes *a* and *b*; the ratio of these intercepts is easily understood from the similar triangles, and the intersections of all the faces with the axial plane *aob* are parallel lines. A zone may be interrupted at any point by the interposition of other faces not belonging to that zone. Zonal relations help very materially in the measurement of

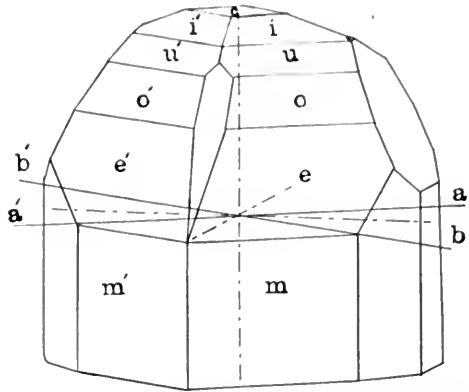

FIG. 31.—Crystal of Topaz in which the Faces *c*, *i*, *u*, *o*, *e*, and *m* are in the Same Zone, the Axis of which is *aa'*.

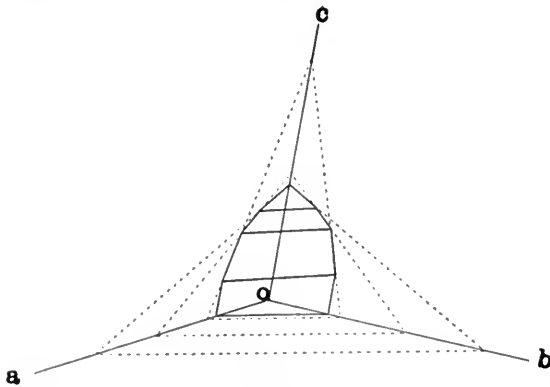

FIG. 32.

crystals, for once a face has been located as a member of a zone, its parameters when determined must fulfill the zonal relations.

Fundamental forms.— Among the faces found on the crystals of any substance, a face which cuts all three axes, and is simply related to all other faces occurring on the crystals, is selected; its intercept on each axis is taken as the unit of measurement on that axis; its parameters would be *a* : *b* : *c*; the form is termed the

unit, or **fundamental** form, to which all other faces are referred. The intercepts of the unit form on all interchangeable axes are equal, their ratio $\frac{a}{a} = 1$; the intercepts on axes that are not interchangeable are always an indeterminate quantity, $\frac{a}{b} = 0.81520^+$; $\frac{c}{b} = 1.31359^+$, when **b** is taken as unity and express the ratio of the units on the axes. The axial ratios of barite are written $\check{a} : \bar{b} : \dot{c} = 0.81520 : 1 : 1.31359$. For chemically pure substances the axial ratios are constant and are characteristic of the substance, just as much as any of its chemical properties. The axial ratios and the value of the interaxial angles in the monoclinic and triclinic systems, which are also constant for pure substances, are termed the **crystalline characters** or **elements**. The crystalline characters in the isometric system are determined by all the axes being interchangeable; they are the same for all substances that crystallize in the system; $\frac{a}{a} = 1$. In the tetragonal system, $\frac{c}{a} = \frac{c}{1} = 0.1644154^+$, axial ratio of rutile. In the hexagonal system $\frac{c}{a} = \frac{c}{1} = 9.734603^+$, apatite. In the orthorhombic system there are two axial ratios, $\frac{a}{b}$ and $\frac{c}{b}$, $\check{a} : \bar{b} : \dot{c} = 0.81520^+ : 1 : 1.31359^+$, axial

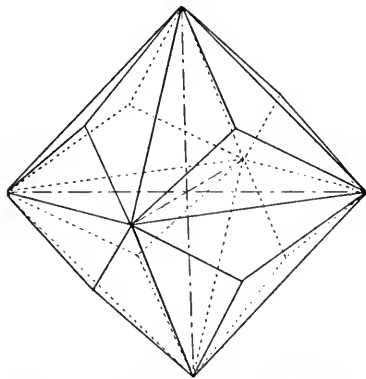

FIG. 33. — Holohedral Form $a : c : 3a$,
(331).

ratios of barite. In the monoclinic system the two axial ratios and the value of the angle β are the crystalline characters; $\check{a} : \bar{b} : \dot{c} = 0.658510^+ : 1 : 0.55538^+$, $\beta = 63^\circ 56' 46''$, orthoclase. In the triclinic system there are three angles in addition to the axial ratios:

$$\begin{aligned} \check{a} : \bar{b} : \dot{c} &= 0.49211^+ : 1 : 0.47970^+; \\ \alpha &= 82^\circ 54' 13''; \\ \beta &= 91^\circ 51' 53''; \\ \gamma &= 131^\circ 32' 19'', \text{ axinite.} \end{aligned}$$

Holohedral, **holosymmetric**, or **normal**, are terms denoting a type of crystals in each system, in which the symmetry requires all the faces possible to be represented by one set of parameters to be present to complete the

form. The set of parameters $a : a : 3a$ represents three faces in each octant, as here the axes are interchangeable and when one axis is cut all must be cut by a plane at 3; these three planes are represented by $(a : a : 3a)$, $(a : 3a : a)$, $(3a : a : a)$, or 24 faces in the eight octants; Fig. 33 represents this form.

Hemihedral form is the term used to denote those types in which the symmetry requires only one half of the faces possible to be represented by one set of parameters, to be present to complete the form. There are several classes of hemihedrons, according to their symmetry. If the most general form of a system as $(a : 2a : 3a)$, represented by Fig. 34, with 48 faces, is taken, there may be numerous ways of selecting one half of these 48 faces; the symmetry of the types allows but three to form hemihedrons.

I. By taking all the faces in alternate octants and extending them until they inclose space, as the shaded faces of Fig. 35, which when

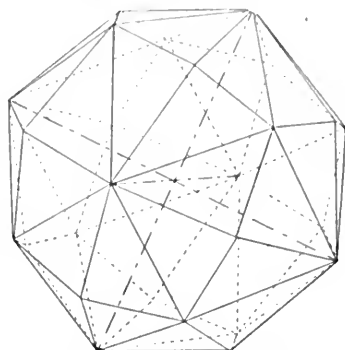

FIG. 34.—The Hexoctahedron,
 $a : 2a : 2a$.

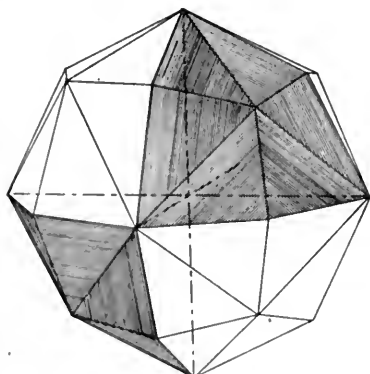

FIG. 35.

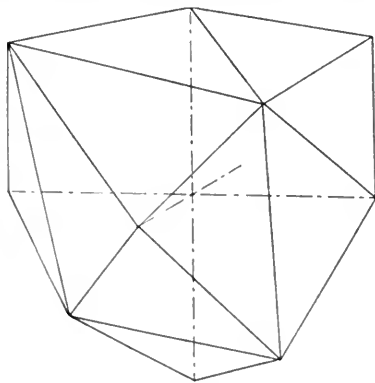

FIG. 36.

extended will produce the form represented in Fig. 36. Since some holohedrons have a center of symmetry and are formed of pairs of parallel faces; this class of hemihedrons in which one face of each pair of faces of the holohedron is extended, will not be formed of

pairs of parallel faces, and for that reason they are known as the diagonal-faced hemihedrons, represented in the Miller system of indices by $\kappa(\mathbf{hkl})$.

II. By selecting one half of the pairs of faces, taking those which intersect in the axial planes, as represented in Fig. 37; these when

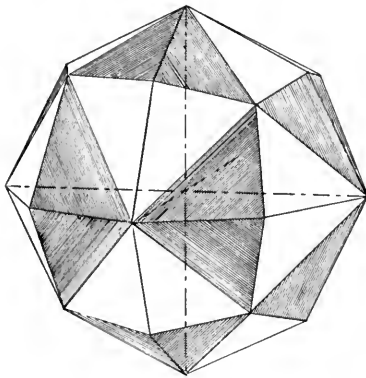

FIG. 37.

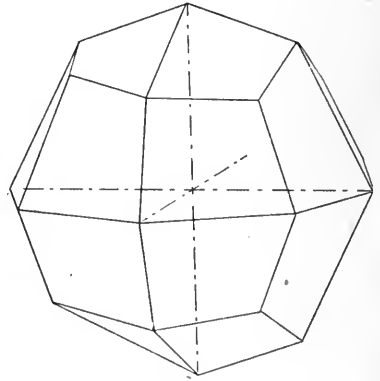

FIG. 38.

extended will produce the hemihedral class, Fig. 38, known as the parallel-faced hemihedrons, designated in the Miller system by $\pi(\mathbf{hkl})$.

III. By selecting every other face around the extremity of an axis, and those alternating with it around the adjacent axis, as represented by the shaded faces in Fig. 39; these when extended will

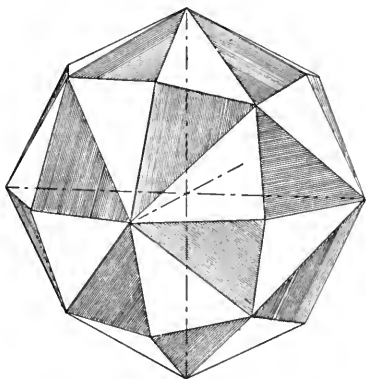

FIG. 39.

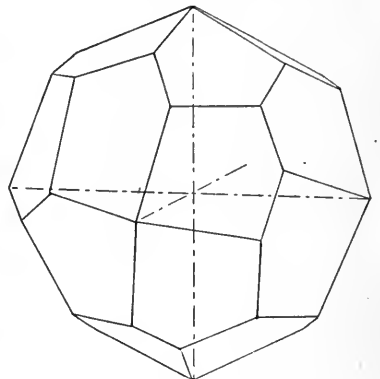

FIG. 40.

produce the gyroidal, or plagiohedral, class of hemihedrons, represented in Fig. 40. These are denoted in Miller's system by $\tau(\mathbf{hkl})$.

In all cases there are two forms of hemihedrons possible to be derived from each holohedron, for the white faces in each case could be extended to obliterate the shaded faces; one of these is the +, the other the - hemihedron, in classes I and II. In class III they are right and left forms.

Tetartohedral forms. — In some types of crystals with still lower symmetry, only one quarter of the face of the general form may be required by the symmetry to complete the form; such forms are termed tetartohedrons. The faces extended to form tetartohedrons must in each case modify the extremities of interchangeable axes in the same manner. If in Fig. 41 the shaded faces are extended, the tetartohedral form of Fig. 42 will be produced, having 12 faces. This is the right positive form, designated $+R \frac{a:2a:3a}{4}$ or $\pi k (hkl)$. If the three unshaded faces in the upper right octant and the corresponding faces in other octants are extended, the + left form will be produced. These two forms are

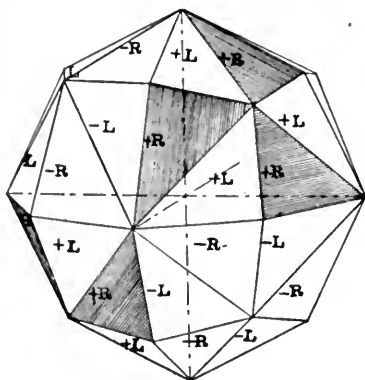

FIG. 41. ($a:2a:3a$.)

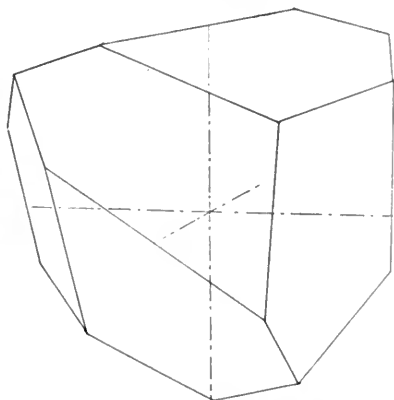

FIG. 42. $+R \left(\frac{a:2a:3a}{4} \right)$.

mirror images of each other; there is no way in which they can be revolved into congruent positions. It is like a left glove on a right hand; such forms are **enantiomorphic**. Two other forms are possible: the minus right produced by extending the faces - R, Fig. 41, and the minus left produced by extending - L. There are always four tetartohedral forms possible, the \pm rights and the \pm lefts; the rights are congruent with each other and the lefts are also congruent, but the rights are enantiomorphic with the lefts.

Models. — In the study of crystals and the relation of crystal forms, models cut from wood are indispensable. The student should

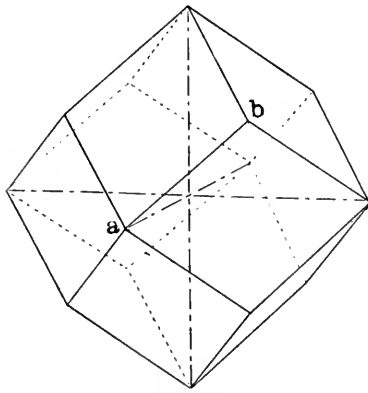

FIG. 43.

cut the simpler forms and their combinations from cork, as relations once established in this way are never forgotten. Crystal models are cut showing similar faces of the same size, or equally developed, thus representing the ideal symmetry of crystals, Fig. 43. In nature crystals seldom if ever present the ideal symmetry, as some faces are always enlarged at the expense of others; in this way some faces may be entirely obliterated, when the appearance

of a crystal may be so changed by the unequal development, or **distortion**, as to be difficult of recognition. Distortions take the form of elongation along a set of parallel edges, as in Fig. 44, a

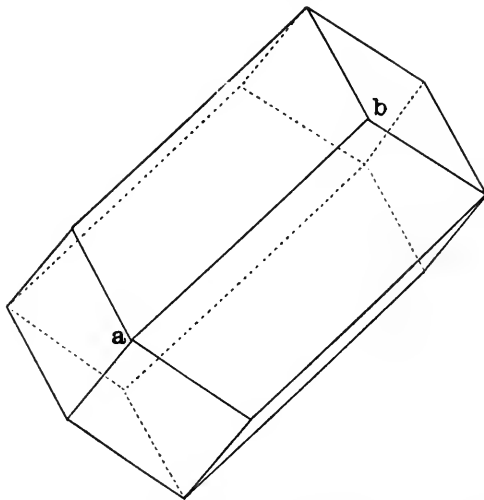

FIG. 44. — A Distorted Rhombic Dodecahedron of Garnet.

distorted rhombic dodecahedron of garnet with the edges parallel to **ab** elongated; again, in the distortion of crystals, points are replaced by edges, as in Fig. 45 a and 45 b, a regular crystal of quartz

and a distorted crystal in which parallel edges *c* and *d* replace the points *c* and *d*, and the edge *ab* is elongated.

Habit. — Different combinations of the various forms in which a substance may crystallize will produce crystals of widely varying

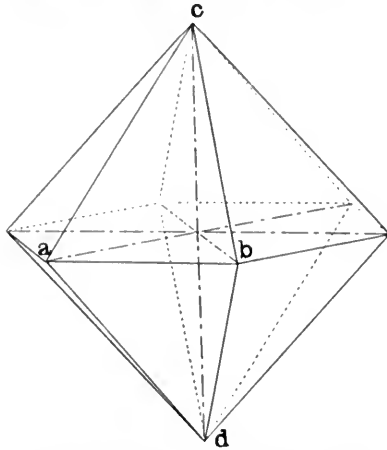

FIG. 45 a. — Symmetrical Quartz Crystal.

shapes, and especially when combined with distortions. These combinations, peculiar to localities or conditions of crystallization, are known as the habit. Forms will be found on crystals from one

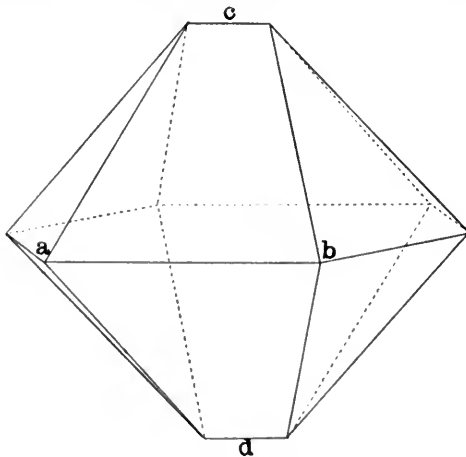

FIG. 45 b. — A Distorted Quartz.

locality which may not necessarily be found on those from another. Even though the forms are identical, their relative development will

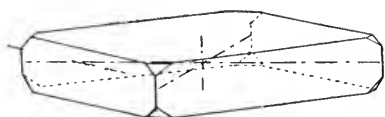

FIG. 46. — Tabular Habit of Barite from Felsöbanya.

yield a crystal of an entirely different appearance. Figure 46 is a crystal of barite from Felsöbanya with a tabular habit; Fig. 47 is a crystal of barite from Cumberland, Eng-

land, with a prismatic habit, being elongated parallel to the **b** axis; the two crystals present combinations of the same forms; their different appearance is due to inequality of development.

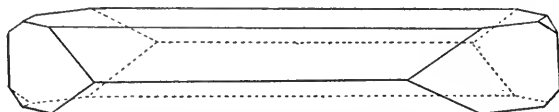

FIG. 47. — Elongated Habit of Barite; a Combination of the Same Forms as in Fig. 46.

CHAPTER II

CRYSTALLOGRAPHY

Drawing of crystals. — The object to be attained in the drawing of crystals may be either to represent their relation and habit in perspective, or to represent the relation of forms on individual crystals. The methods in use for this purpose are those of general projection, though modified in some cases to fit the conditions. The edges of crystals are formed in every case by the intersection of two faces; in the drawing they are represented by straight lines; to find the position, inclination, and foreshortening of any edge is nothing more than a problem in the intersection of planes. The position of each face is given by the crystallographical symbols. Interfacial angles are used in the drawing, only in so far as they are necessary to determine the axial ratio and intercepts. The methods of perspective projection are modified, not only to simplify the construction, but to adapt it to the representation of crystal edges, so that edges parallel on the crystal will be parallel in the drawing, and of a length proportional to their actual length on the crystal. This modification is simply placing the eye at infinity; all rays will then be parallel. All parallel and zonal directions will be preserved; it will be necessary to determine the direction of only one edge of a zone in the drawing, all other edges in the same zone will be parallel. It is customary to represent the ideal symmetry of a crystal in the drawing, unless it is wished to illustrate some peculiar development or habit. There are two general methods of projection, the **orthographic** and **clinographic** methods, both of which place the eye at infinity.

Orthographic projection is a plan or map of the crystal faces and edges, drawn on a plane perpendicular to the \hat{c} axis. It represents in crystallography exactly what the foundation and roof plans of a house do to a builder. When the plane of projection is perpendicular to the \hat{c} axis the eye will lie in the direction of the \hat{c} axis, at an infinite distance, vertically above the plane; the \hat{c} axis will appear

as a point in the center of the drawing at the intersection of the lateral axes. All edges parallel to \bar{c} will also appear as points. Planes parallel to the \bar{c} axis will appear as straight lines. The angles between these planes will be represented of true size.

Edges parallel to the plane of projection will also be represented in the drawing by lines equal to the lengths of the edges; edges inclined to the plane will be proportional to their inclination. Supposing it is wished to represent the crystallization of barite, axial ratio, $\bar{a} : \bar{b} : \bar{c} = 1.815^+ : 1 : 1.313^+$, and the following forms:

$$\begin{array}{ll} a = (100) = \bar{a} : \infty \bar{b} : \infty \bar{c}, & b = (010) = \infty \bar{a} : \bar{b} : \infty \bar{c}, \\ c = (001) = \infty \bar{a} : \infty \bar{b} : \bar{c}, & d = (102) = 2 \bar{a} : \infty \bar{b} : \bar{c}, \\ m = (110) = \bar{a} : \bar{b} : \infty \bar{c}, & p = (111) = \bar{a} : \bar{b} : \bar{c}, \end{array}$$

When the indices alone are given it is necessary to transform them to Weiss parameters, as these represent the proportional intercepts on each axis. As the two lateral axes appear in the drawing in their true length, lay out from c , Fig. 48, the vertical axis, a distance cb and cb' each equal to b , the selected unit of length; at right angles to cb' , as barite is an orthorhombic mineral, lay off ca and ca' , each $= cb \times .815$; through b, b' draw lines parallel to aa' , which will represent the form (010) ; through a, a' draw lines parallel to bb' representing the form (100) ; m (110) would be represented by joining the extremities of the axes a and b , but the cross section can be varied to suit the crystal at hand, by moving the line connecting a, b out to a parallel position m , when m, m', m'', m''' drawn symmetrically will represent the four faces of the unit prism, m (110) ; these four lines will also represent the intersection of the unit pyramid, p (111) , with m (110) . The apex of the pyramid is at c and the ridges will fall on the axes a and b . The base c (001) is in the same zone as m (110) and p (111) , therefore the intersection of c and p will be parallel to the lines m, m', m'', m''' . The size of the base can be varied by the distance from c at which the four lines are drawn. Of the forms to be represented there

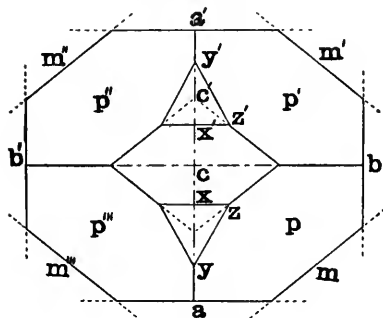

FIG. 48. — Orthographic of Barite.

parallel to bb' representing the form (100) ; m (110) would be represented by joining the extremities of the axes a and b , but the cross section can be varied to suit the crystal at hand, by moving the line connecting a, b out to a parallel position m , when m, m', m'', m''' drawn symmetrically will represent the four faces of the unit prism, m (110) ; these four lines will also represent the intersection of the unit pyramid, p (111) , with m (110) . The apex of the pyramid is at c and the ridges will fall on the axes a and b . The base c (001) is in the same zone as m (110) and p (111) , therefore the intersection of c and p will be parallel to the lines m, m', m'', m''' . The size of the base can be varied by the distance from c at which the four lines are drawn. Of the forms to be represented there

object of the orthographic method. The disadvantage of the method is that no angles and only those edges which are parallel to the c axis are given their true size in the drawing; one method

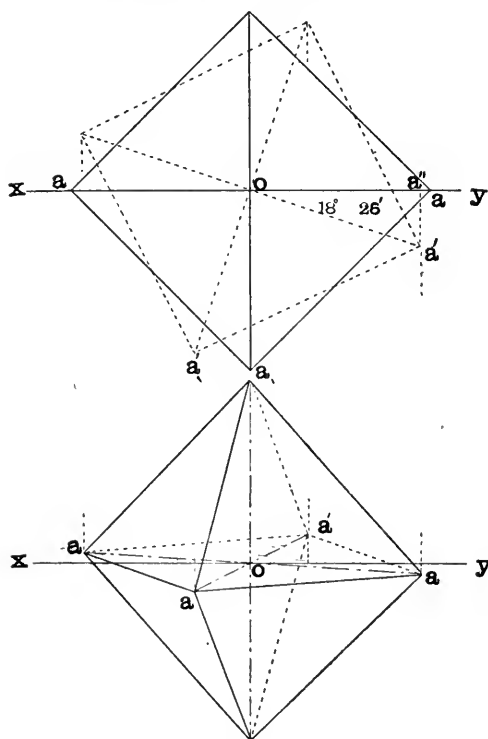

FIG. 49.

therefore supplements the other and crystals should be illustrated by both methods. In the clinographic method the crystal is projected upon a vertical plane containing the c axis. The c axis is the only one given its true length in projection. In Fig. 49 an octahedron is represented in orthographic projection; in order to pass to the clinographic two steps are necessary: 1st, the crystal is revolved around the c axis some selected angle, usually $18^{\circ} 26'$, after this revolution the octahedron will assume the position of the dotted lines. The axis oa will be moved to oa' ; when projected upon the plane of projection of which xy is the trace it will appear foreshortened as oa'' ; in the same manner oa_1 will appear upon the plane of projection as oa_1' ; the amount of foreshortening will depend upon the angle of revolution. 2d, after the revolution about the c axis, in order that the plane of the lateral axes shall not be represented in the drawing, by a line, as xy , the eye, hitherto at infinity in a horizontal direction, is now elevated until the lines of vision form an angle, selected generally as $9^{\circ} 28'$, Fig. 50, with the horizontal plane. It is as if the eye, being at the same height above the floor as the table top, the relative positions of objects on the table would not be appreciated, as the lines of vision are parallel to the table top; if the eye is elevated, the top will come immediately into

view and the relative positions of objects on the table is at once seen. A clinographical projection of an octahedron is represented in Fig. 49, in which the projection of the plane of the lateral axes — $aa'a$ is the result of an elevation of the eye $9^\circ 28'$. Referring to Fig. 50, cc' is the trace of the plane of projection; it will be seen that every point on the horizontal plane in front of the plane cc' will appear below o , and every point behind cc' will appear above o ; the distance above or below o at which any point will appear depends upon the angle

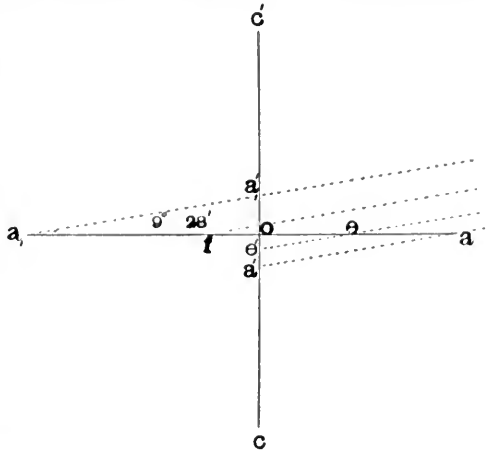

FIG. 50.

of elevation of the eye and the distance from o of the point in question. Take any point a , Fig. 50, the line of vision aa' is $9^\circ 28'$ from the horizontal, and a will appear on the plane of projection at a' . In the triangle aoa' , where $oa = 1$, $oa' = \text{the tangent of } oaa' = \text{tangent } 9^\circ 28' = \frac{1}{6} oa$; the point a_1 will appear at a'_1 , $\frac{1}{6}$ of a_1o

above o ; the point e will appear at e' , $\frac{1}{6} oe$ below o , etc. When the angle of elevation is $9^\circ 28'$, $\frac{1}{6}$ the distance of any point from the plane of projection, measured below o if the point is in front and measured above o if the point is behind the plane of projection, will determine the projection of the point in question.

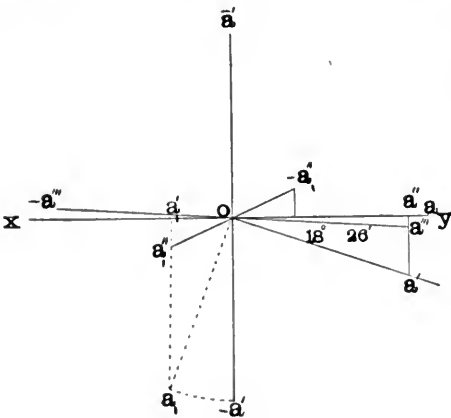

FIG. 51.—The Axial Cross of the Isometric System.

illustrate some peculiar conditions the angles $18^\circ 26'$ and $9^\circ 28'$ have proven the most satisfactory and are in general use.

Construction of the axial crosses.— Unless to

angles $18^\circ 26'$ and $9^\circ 28'$

Isometric.— Draw xy , Fig. 51, the trace of the horizontal plane with the plane of projection, and $-a'a'$ at right angles, making

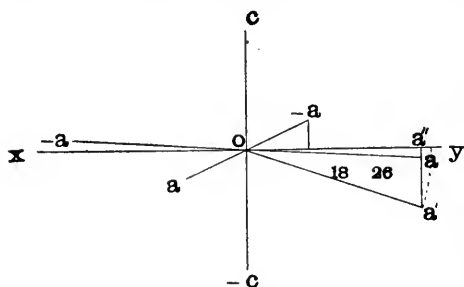

FIG. 52.—Axial Cross of Zircon; $\dot{c} = 0.64+$.

$o - a'$, $\dot{a}o$ = the true length of the axis oa . Draw oa' at $18^\circ 26'$ to xy , making $oa' = oa$; draw $a'a''$ at right angles to xy ; as a' is in front of xy lay off a distance $a''a''' = \frac{1}{6} a'a''$, draw oa''' and extend it to $-a'''o$, making $-a'''o = a'''o$; then $-a'''a'''$ will be the projection of the axis. The axis at right angles to this is gotten by drawing oa_1 at right angles and equal to oa' ; draw a'_1a_1 perpendicular to xy and make $a_1''a_1' = \frac{1}{6} a'_1a_1$; draw $a_1''o$, extend to $-a_1''o$, making $-a_1''o = oa_1''$, when $-a_1''a_1''$ will be the projection and relative length of the second lateral axis. The three lengths $a'''o$, $a_1''o$, $-a'o$ all represent the same unit of length as measured in turn on each of the axes; by connecting the extremities of the three axes the clinographical projection of the unit form or octahedron will be obtained, Fig. 49.

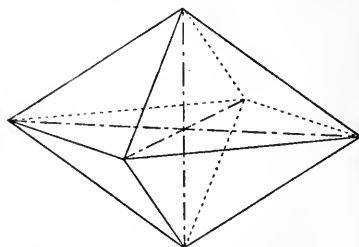

FIG. 52a.—The Unit Pyramid of Zircon; $\dot{c} = 0.640$.

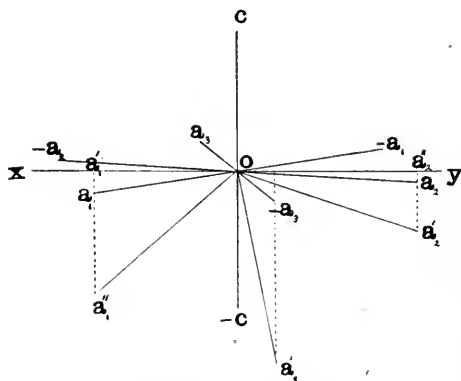

FIG. 53.—Axial Cross of Apatite; $\dot{c} = 0.734+$.

Tetragonal.— The tetragonal system will not differ from the construction in the isometric, except that the \dot{c} axis is not equal to the lateral axes. Draw xy , Fig. 52, and find the projections of the two lateral axes exactly as described in the isometric cross; at o draw $oc = -co = oa \times$ (the axial ratio of the mineral to be represented), in

zircon .640. The unit pyramid of zircon will be projected by connecting the three axial units, Fig. 52*a*.

Hexagonal.—Here the problem of the axial cross differs, as the lateral axes are three and not at right angles. Draw *xy*, Fig. 53, and project \dot{c} and a_2 as before.

Draw $a_2'o a_3' = 60^\circ$, making $a_3'o = a_2'o$, then draw $-a_3'a_3$ parallel to $-cc$, placing $-a_3$, $\frac{1}{6}$ the distance from *xy* as a'_3 , when $-a_3a_3$ will be the projection of the axis required. The third lateral axis is found by laying off the angle $a_3'o a_1'' = 60^\circ$ and following the same construction as before; by connecting the extremities of all the axes the unit pyramid will result, Fig. 54.

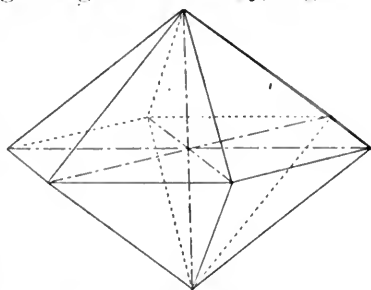

FIG. 54.—The Unit Pyramid of Apatite.

Orthorhombic.—Here the three axes are at right angles, but all of a different length. Taking barite as an example, where $\dot{a} : \dot{b} : \dot{c} = .81^+ : 1 : 1.313$, to project the axial 'cross. Draw *xy*,

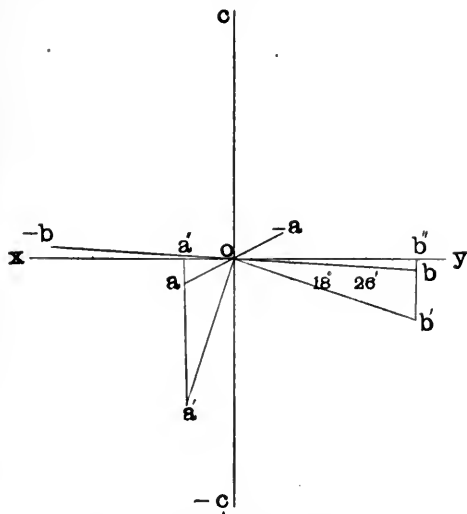

FIG. 55.—Axial Cross of Barite.

Fig. 55; lay out ob' at $18^\circ 26'$ from *y* and some selected unit in length as 50 mm.; find the projection of *b* as before. The \dot{c} axis is found as in the tetragonal system, $oc' = 50 \text{ mm.} \times 1.313^+ = 65.65 \text{ mm.}$ The *a* axis is found by laying off oa' at 90° to ob' , and $= 50 \text{ mm.} \times .81 = 40.5 \text{ mm.}$, when the projection $-aa$ is obtained as before; connecting the extremities and Fig. 56 will represent the unit pyramid of barite.

Monoclinic.—Here the problem differs in that the clinoaxis \dot{a} is not at 90° to the vertical axis \dot{c} . Let it be required to draw the axial cross of amphibole, $\dot{a} : \dot{b} : \dot{c} = .55^+ : 1 : .29^+$, $\beta = 73^\circ 58'$.

Project \dot{b} and \dot{c} as in the orthorhombic system; to find the pro-

jection of **a** it is necessary to understand the position of the angle β ; the position of β is always back, Fig. 57, of the plane of projection, here represented by $-cc$;

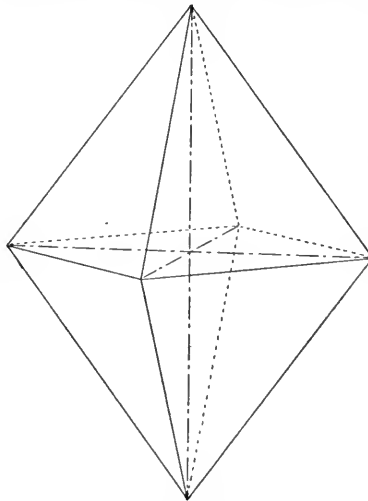

Fig. 56.—The Unit Pyramid of Barite.

its value is always taken less than 90° . Therefore the angle between the \hat{c} and \hat{a} axes in front will be greater than 90° , in this case $106^\circ 2'$, and the extremity of the \hat{a} axis in front will be below the horizontal plane a distance oa''' , depending upon the value of the angle β and the length of the \hat{a} axis. This distance is found by drawing $-\hat{a}oc = \beta$ and extending in the direction of **a**, making $oa = ob \times 0.55^+$; draw aa''' at $9^\circ 28'$ with the horizontal, then the projection of the end of the clinaxis in front will appear below **xy** a distance oa''' , due to the angle $\beta + a''a'''$ ($\frac{1}{6} aa''$) due to the angle $9^\circ 28'$. Therefore lay out in Fig. 58 the angle $aoa' = 16^\circ 2'$ and oa' = the unit on the \hat{a} axis, then the extremity of the **a** axis will appear below **xy** a distance aa' due to the angle β , then by the revolution of $18^\circ 26'$ and the elevation of the eye $9^\circ 28'$, the projection of the extremity will fall under a''' , a distance $\hat{a}a''' = aa' + \frac{1}{6} a''a'''$; connect \hat{a} with **o** and extend to $-\hat{a}$

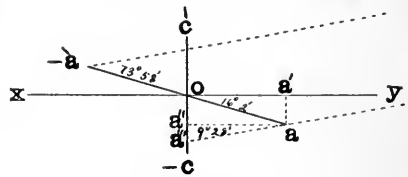

Fig. 57.

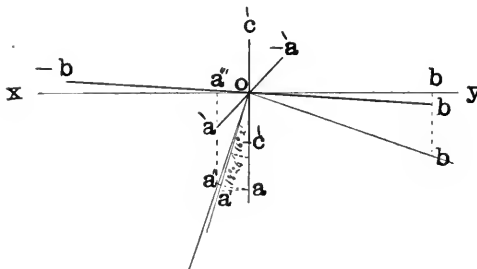

Fig. 58.—Axial Cross of Amphibole.

an equal distance, when $-\hat{a}a'$ will be the projection of the clinaxis; connecting the extremities of the projected axes, when Fig. 59 will represent the unit pyramid of amphibole.

Triclinic.—Let it be required to draw the

axial cross of rhodonite, $\bar{a} : \bar{b} : \bar{c} = 3.072^+ : 1 : .6212^+$; $\alpha = 193^\circ 18'$; $\beta = 108^\circ 44'$; $\gamma = 81^\circ 39'$; and the angle $100,010 = 94^\circ 26'$.

The construction of the \bar{c} and \bar{a} axes is the same as in the monoclinic system, here the plane containing the \bar{b} and \bar{c} axes is not at 90° from that containing the \bar{a} and \bar{c} axes, but as in this case is $94^\circ 26'$. Having constructed the projections of \bar{a} and \bar{c} , lay off the angle $a''ob' = 100,010 = 94^\circ 26'$, make $bob' = \alpha - 90 = 13^\circ 18'$; make ob the true length of \bar{b} , draw bb' at 90° to ob' . The extremity of the \bar{b} axis will lie below the horizontal plane a distance bb' , due to the angle being $13^\circ 18'$ larger than a right angle; draw $b'b''$ at 90° to xy ; the projection of \bar{b} will lie on the line

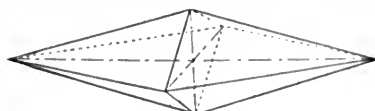

FIG. 59. — The Unit Pyramid of Amphibole.

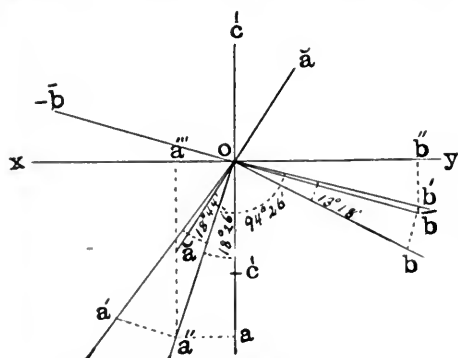

FIG. 60. — Axial Cross of Rhodonite.

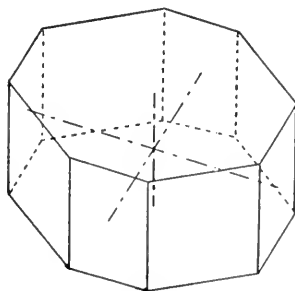

FIG. 61.

$b'b''$, extended, if necessary, a distance $b''\bar{b} = bb' + \frac{1}{6} b'b''$, $\bar{b} - \bar{b}$ will then be the projection of the axis \bar{b} . Figure 61 represents the combination of (100); (010), (001), (110) of rhodonite.

Example I of clinographic projection. After the axial cross is projected, the clinographic projection of any crystal is a problem in the intersections of planes; the inclination of the faces is given by the parameters. Let it be required to project clinographically the same forms used to illustrate the orthographic method on page 32. Construct the axial cross and connect the extremities of the axes, Fig. 62, which will represent the unit pyramid (111); the base, $c = (001)$, will truncate the pyramid above and below o , and will be parallel to the plane containing the axes \bar{a} and \bar{b} . Let it cut the \bar{c} axis above at c , below at c_1 . This distance will depend upon

the development of the crystal to be illustrated, as all faces may be moved back and forth on any axis, if their inclination be not changed. The intersection of c with the edge of the pyramid is

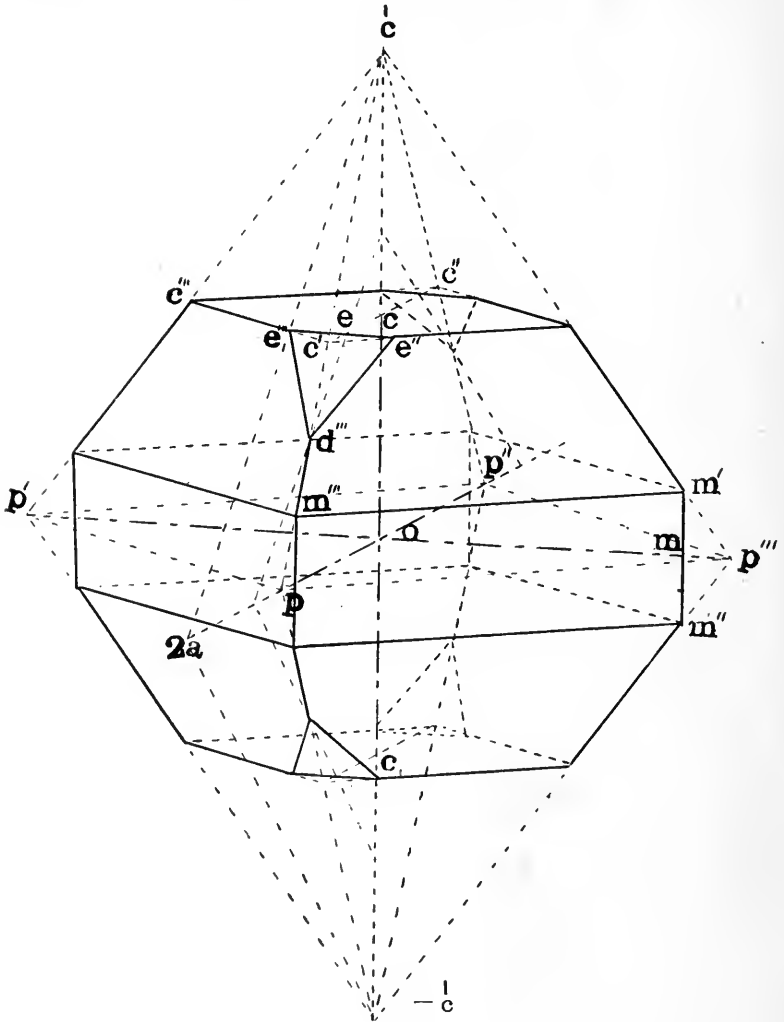

FIG. 62.

found by drawing $c'c''$ parallel to the axis \check{a} ; where this line intersects the edge of the pyramid at c' will be a point common to both the edge of the pyramid and the base; likewise c'' , the intersection of c and p , will be parallel to pp' as the two edges belong to the

same zone; draw $c'c'''$ parallel to pp' , $c'''c''$ parallel to $p'p''$, and so on around the four sides of the base above and below. The unit prism, m (110), is a member of the same zone, and its intersection with the pyramid will be parallel to the intersections of the base and pyramid. If the prism cuts the \bar{b} axis at m , then $m'm''$ drawn through m parallel to oc will represent its edge in projection, and m' , m'' will be points on the intersection of the prism and pyramid; draw $m'm'''$

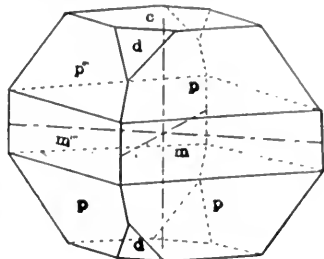

FIG. 63.

parallel to $p'''p$, and so on around the pyramid above and below, dotting edges which will appear behind. To project the remaining form d (102) = $2\bar{a} : \infty\bar{b} : \bar{c}$, lay off on the \bar{a} axis, $2a$, connect $2a$ with \bar{c} and $-\bar{c}$; these lines will be the intersection of the dome with the axial plane $\bar{c}oa$. Move $2ac$ in parallel to itself, until it cuts the edge of the pyramid at d''' and the base at e , the inter-

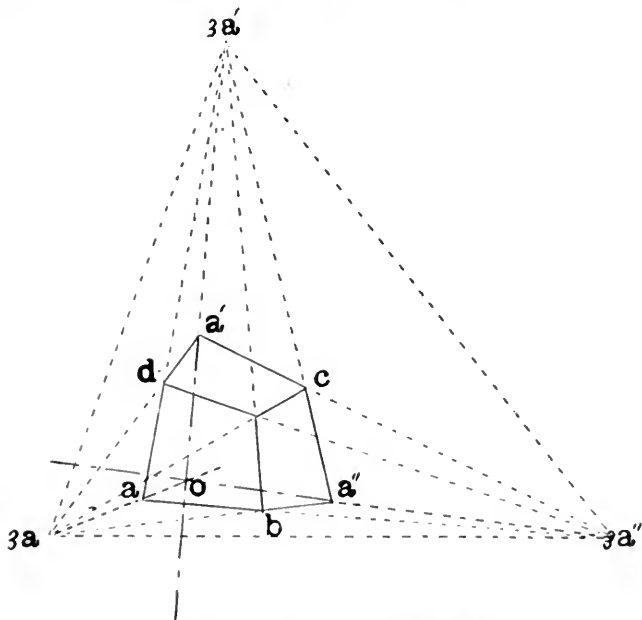

FIG. 64.—One Octant of $3a : 3a : a$.

section of d and c will be parallel to the \bar{b} axis, as both faces are parallel to \bar{b} ; draw ee'' parallel to $p'p'''$ and connect $e''d'''$, $e'''d'''$,

when $e''d'''e'''$ will represent one of the dome faces; the remaining three are projected in a similar way. Figure 63 represents this combination without the construction lines.

Example II. — Let it be required to draw $(113) = 3a : 3a : a$ of the isometric system. Draw the axial cross and extend them in each case to $3a$, Fig. 64; in the isometric system all the axes are interchangeable, and where one axis is cut by planes at 1 and 3 the other axes must be cut by two planes also; there will be three planes in each octant; connect $3a, a'', 3a'$, the three lines will be the intersection of the face $3a : a : 3a$ with the three axial planes separating

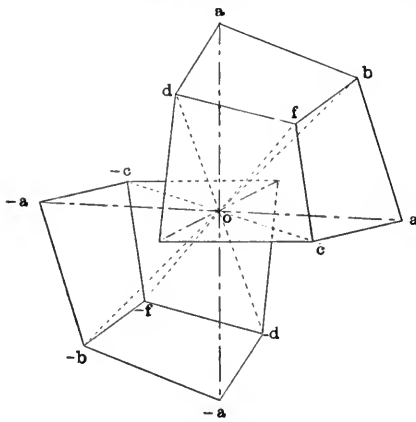

FIG. 65.

the octants; likewise connect $3a', a$, and $3a''$; $3a'', 3a, a'$. The intersections of these three planes are $3ac, 3a''ad, 3a'b$; those portions of the intersections which represent crystal edges are drawn in full lines. The portion of the crystal represented is that contained in one octant or one eighth of the whole form. All edges in the three remaining octants in front of the plane of projection are obtained by the same method

of projection. Those in the four octants behind the plane of projection, where the form is symmetrical in respect to a center, may be conveniently drawn as in Fig. 65. If from any point c a line be drawn to the center o and extended beyond the center an equal distance as co , $-c$ will be the point behind the plane of projection corresponding to c in front, likewise all other points may be located by drawing lines through the center o and the faces represented by connecting these points.

Spherical or stereographical projection.— In the spherical projection the crystal to be represented is placed at the center of a sphere so that the intersection of the crystallographical axes coincides with the center. The plane of projection passes through the center of the sphere at right angles to the c axis, and intersects the sphere in a great circle, the equator; the c axis when extended will intersect the sphere of projection at the north and south poles. The eye is situated at the south pole to view the faces located in

the northern hemisphere and at north pole to view those in the southern hemisphere. Crystal faces are not represented by the projection of their edges, but by the location on the plane of projection of the point of contact with the sphere of a radius perpendicular (the normal) to the face, as viewed from the south pole. In Fig. 66 the plane of projection perpendicular to the paper is represented by bb' , which also represents the b axis; the c axis $c'e$; the a axis perpendicular to the paper will be represented by a point at o . Four faces c , f , d , b , belonging to the zone of which the axis a is the zonal axis, their normals when extended will intersect the sphere at their respective poles c' , f' , d' , b' ; these poles when viewed by the eye at e will appear on the plane of projection, bb' , as if they were actually located at o , f'' , d'' , b' , their projections. The distance from o at which the pole of any face will appear in the projection, as f , is proportional to the tangent of one half the angle foe ; for $of'' = oe \tan oef''$; $oef'' = \frac{1}{2} cof$; $\tan 26^\circ (foe = 26^\circ) = .23$, or the distance of f'' from o is $23/100$ of the radius. It may be seen by the construction of Fig. 66, that all the normals of any one zone will lie in one plane; their poles will all lie on the great circle in which this plane intersects the sphere of projection; therefore the arc between any two poles is a measure of the angle between their normals. It is the supplement of the angle between the crystal faces which the normals represent. The arc $f'd'$ measures the angle $d'of'$, and as the angle $ofa = oda = 90^\circ$, then $d'of' + daf = 180^\circ$. As the angle between the normals is the angle actually measured by the reflecting goniometer, it is the angle reported and used in the descriptions of crystals.

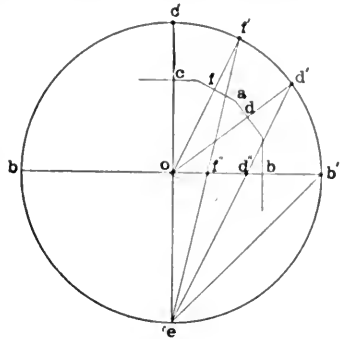

FIG. 66.

All poles in the northern hemisphere when viewed from the south pole will fall upon the plane of projection within the equator or primitive circle. When the plane of projection is a plane of symmetry, the projection of the northern hemisphere will also be a projection of the southern hemisphere as viewed from the north pole. Similar poles above and below will coincide on the plane of projection. All zones or great circles perpendicular to the plane of projection are projected in diameters of the primitive circle; all

zones or great circles inclined to the plane of projection are projected in arcs of circles cutting the primitive circle at the ends of a diameter. Before illustrating by an example the method of drawing the spherical projection of a crystal, it is necessary to have well in mind several problems constantly in use during the construction.

If from the pole of a zone circle, lines be drawn through the poles of any two faces lying upon the zonal circle, and extended until they intersect the primitive circle, the arc of the primitive circle intersected will measure the angle between the normals of the faces.

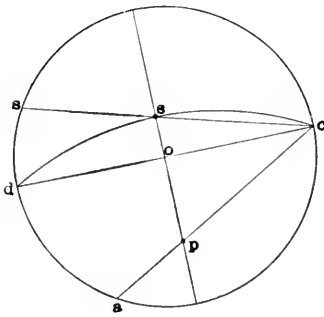

FIG. 67.

where it crosses os at p will be a point on a great circle at right angles to the given zone dsc and 90° from it; it is therefore the pole of dsc .

Problem II.—Given the projection of the pole of any zonal circle, to draw the projection of the circle, is simply the reverse of problem I, Fig. 67.

Problem III.—Through any two given poles to draw the projection of the great or zonal circle to which they belong.

In Fig. 68 let P, S be the two given poles; then draw the diameter po , and oa at 90° to it, then a is the pole of the great circle of which Po is the projection and the given pole P will lie upon it; draw aP , extend it to P' , lay off $P'b = 180^\circ$; draw ab to meet Po extended at B ; B will be the

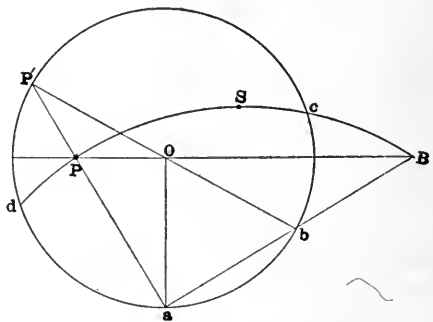

FIG. 68.

drawn. A line is drawn from S perpendicular to PO , meeting the primitive circle at C . A line is drawn from C perpendicular to PO , meeting the primitive circle at D . A line is drawn from C perpendicular to PO , meeting the primitive circle at D .

projection of a point on the sphere at the opposite end of a diameter from **P**; therefore draw a circle through **BSP**, and **cSd** will be the projection of the zonal circle required.

Problem IV. — Given the projection of any two poles, to find the angle between them. In Fig. 69 let **a**, **b** be the given poles; by Problem III draw the zonal circle **dabc**, and find its pole **P** by Problem I; draw **Pa** and **Pb**, extending them to meet the primitive at **a'b'**, then the arc **a'b'** will measure the angle between the normals **ab**.

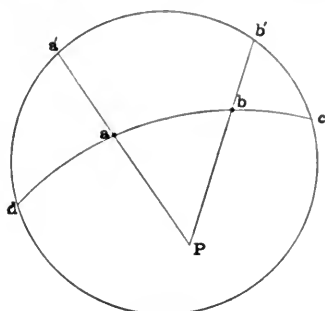

FIG. 69.

Problem V. — Given the zone circle and the projection of one pole in the zone, to find the projection of a face in the same zone at a given angle from it.

This is the reverse of III. In Fig. 69, let **dac** be the zone circle, **a** the given pole, to find the pole **b**, 80° from it. Find the pole **p** of **dac** by I; draw **Paa'** and make $a'b' = 80^\circ$ and draw **b'P**; where it crosses the zonal circle **dac** as at **b** will be the projection of the pole 80° from **a** as required.

Problem VI. — To locate the projection of any pole, the axial ratio and the indices of the face being given.

The axial ratio of barite is $\bar{a} : \bar{b} : \bar{c} = .815 : 1 : 1.313$; locate the pole of $y = (122) = 2a : b : c$.

In Fig. 70 draw the primitive and the two diameters **aa'**, **bb'** at 90° .

Lay off $ob'' = \bar{b}$, the intercept on the axis **a** is $oa'' = 2(\bar{b} \times .815)$; draw **b''a''** and **oc** at 90° to **a''b''**, then **oc** will be the projection of a zonal circle at 90° to the primitive with its pole at **P**, on which the pole of **122** will lie. Lay off $oc' = \bar{b} \times 1.313$, or the unit on the vertical axis, and $od = oc$, connect **d** and **c'**; the angle $c'do$ = the angle between the normal of **y**, **(122)** and the normal to the base **oo1**; draw **Poc''**, and make $c''oy' = c'do$, draw **y'P**; where it crosses **oc** as at **y** will be the projection of the pole of **122** as required.

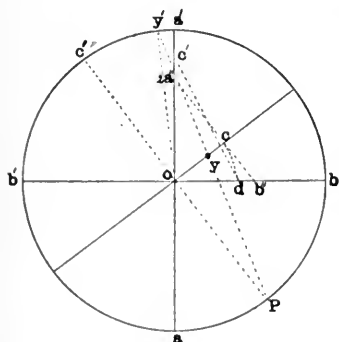

FIG. 70.

Example. — Let it be required to project a barite crystal with the following forms: (100) (010) (001) (110) (102) (011) (111) (112) : $110_A \bar{1}10 = 78^\circ 22'$: $001_A 102 = 38^\circ 51'$: $001_A 011 = 52^\circ 43'$: $001_A 112 = 45^\circ$.

Draw, Fig. 71, the primitive circle within or upon which all poles will fall. As the *c* axis is projected at the center of the primitive,

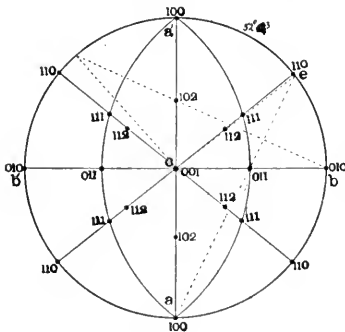

FIG. 71.

and is normal to the base, 001 , *c* at the center will be the pole of 001 . Draw two diameters aa' , bb' at 90° ; these will represent the \bar{a} and \bar{b} axes. The poles of all the faces belonging to the zone of which \bar{c} is the axis will fall on the primitive circle, as their normals will lie in the plane of the paper, the last term of their indices will be *o*. 100 will be projected at the extremities of the axis \bar{a} , 010 at the

extremities of \bar{b} ; the remaining member of this zone (110) will lie symmetrically on either side of the axis \bar{b} . Draw the two diameters at $78^\circ 22'$, and the poles of (110) will lie at their extremities.

The form (011) is a member of the zone of which the axis \bar{a} is the zonal axis; its poles will lie on the diameter of the primitive, perpendicular to \bar{a} , $52^\circ 43'$ from the pole *c*. From a' lay off $a'e = 52^\circ 43'$, draw ea and where it crosses bc is the pole 011 ; $0\bar{1}1$ will be an equal distance on the other side of *c*. The poles of (102) will lie on the diameter aa' and are located by the same method as (011). The two pyramids (111), (112) are members of the zones $110 - 001$ and $\bar{1}10 - 001$, their poles will lie on these two diameters. The form (111) is also a member of the zone $011 - 100$ and $0\bar{1}1 - 100$, its poles will be situated at the intersection of the two zonal circles. Draw the zonal circle $100, 011, \bar{1}00$; where this intersects the zone $110, 001, \bar{1}10$ as at 111 will be the pole of the unit pyramid. Poles of (112) are located by the angle $001, 112 = 45^\circ$; when the angle between the base and any face is given, the zone being known, its poles are quickly found by the tangent rule, or by construction, problem V.

The advantages of the stereographical projection are, that it shows at once the symmetry of the crystal, connects all faces belonging to the same zone, and by simple construction the angle between any two faces may be measured.

CHAPTER III

ISOMETRIC SYSTEM

THE 32 TYPES OF CRYSTALS

CRYSTAL forms, from a consideration of their symmetry alone, are grouped into 32 types; when referred to their axes, they fall into six systems. The types which are included in any one system are independent, and one type cannot combine with another to form crystals even though they belong to the same system; each type possesses a symmetry entirely its own, a characteristic derived from the molecular arrangement and molecule itself. At the same time all those included in one system are related by the possession of axes or planes of symmetry to a large extent common to the group. For this reason the old classification of holohedrons, hemihedrons, etc., is also given, and their derivation one from the other, as the best method for the beginner to obtain a clear understanding of the relation of types and the influence of planes and axes of symmetry in the development of crystal forms.

Under the isometric system are grouped all those crystal forms which are referred to three equal interchangeable axes, intersecting at 90° . It includes five types, all of which are characterized by at least four trigonal and three digonal axes of symmetry. Since the crystallographical axes are all equal, they are designated by the symbol a , and a becomes the unit of measurement on these axes. The most general set of parameters is therefore $na : a : ma$, in which the two variables n and m may have any value between unity, when the plane intersects that axis at unit length or a , and infinity, when the plane is parallel to that axis, or intersects it at infinity. From this standpoint all forms in the system may be considered as special cases of the most general form.

CLASS, ISOMETRIC HOLOHEDRAL, HOLOSYMMETRIC, OR NORMAL TYPE 32, DITESSERAL CENTRAL

This type possesses the highest symmetry possible in any crystal form, and, as in all holohedral classes, the forms are bounded by

pairs of parallel faces. Diagram Fig. 72 represents the symmetry; **13** axes, **9** planes, and a **center**. The value and position of the axes and planes may be understood best by the consideration of their relation to the edges of the cube or hexahedron.

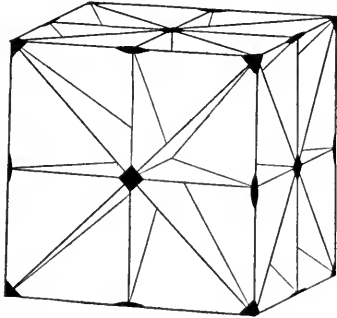

FIG. 72.

There are **three** ditetragonal axes ending in the center of the cube faces, these are the crystallographical axes; **four** ditrigonal axes ending in the corners; **six** didigonal axes ending in the middle of the edges; **three** planes of symmetry bisect the edges of the cube, and contain the crystallographical axes; they intersect in the center of symmetry and divide space around it into eight equal portions (octants). The remaining six planes contain the edges, each plane passing through the center and opposite edges. The nine planes of symmetry divide space around the center into **48** equal triangular solid angles.

Forms

I. Hexoctahedron; $na : a : ma$; (hkl), Fig. 73.

Here the values of the coefficients, **m** and **n**, are independent of each other and not at their limiting values, **1** or ∞ . When **n** = **2** and **m** = **3**, yielding the parameters **3a : a : 2a**, they will locate a face in each one of the **48** triangular segments into which the planes of symmetry divide space, or **48 scalene triangles**. This is the largest number of faces possible on any crystal form. Eight faces are symmetrically grouped around the extremities of the ditetragonal axes (crystallographical axes); six around the ditrigonal axes (center of the octants); four around the didigonal axes. All faces are similar scalene triangles, each of which intersects one axis at unity, the second at a greater distance, the third at a still greater distance. Faces, edges, and

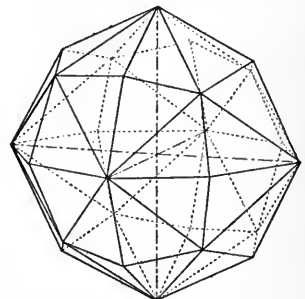
FIG. 73.—The Hexahedron,
 $3a : a : 2a$.

angles of the form will vary with the value of m and n , there is therefore a series of hexoctahedra, of which $3a : a : 2a$ is one.

The spherical projection of the hexoctahedron is represented in Fig. 73 *a*. The planes of symmetry are represented by the great circles in which they cut the sphere of projection. The poles of the faces in the northern hemisphere are represented by small circles, those in the southern hemisphere by crosses. The cross within the circle indicates that the two hemispheres are mirror images of each other, and the type is equatorial. The points at which the axes of symmetry emerge are indicated by the conventional signs.

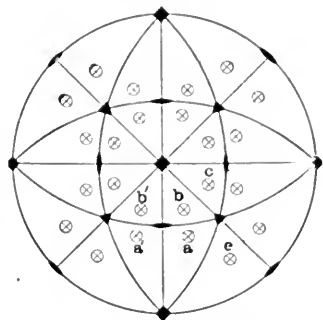

FIG. 73 *a*.—Hexoctahedron.

II. Tetrahexahedron; $na : a : \infty a$; (hko), Fig. 74.

This form is a special case of (hkl), where $l = o$; or each face cuts one axis at ∞ , one at unity, and one at an intermediate distance. If the poles of (hkl) are moved, so as to lie in the diametral planes, Fig. 73 *a*, two normals will coincide, as a with a'

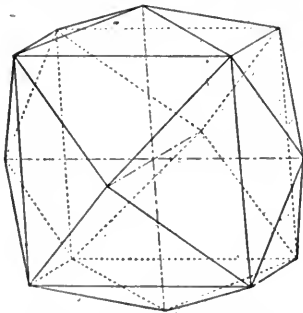

FIG. 74.—The Tetrahexahedron (320), of Fluorite.

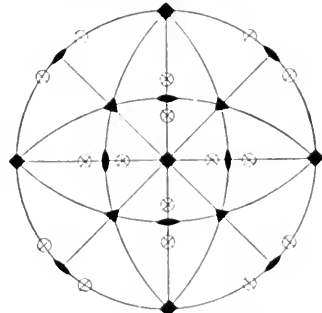

FIG. 75.—Tetrahexahedron (320).

or b with b' , producing a form bounded by 24 isosceles triangles. Four faces are grouped around the ditetragonal axes, Fig. 75, and six around the ditrigonal, and the didigonal axes bisect the basal edges between adjacent faces. The solid angles will vary with the value of n , yielding a series of tetrahexahedra, members of which may occur in combination. The form may also be considered as derived from the cube by replacing each face with four triangles.

III. Tetragonal Trisoctahedron; $na : a : na$; (hhl) , Fig. 76.

If in place of moving the pole of the most general form (hkl) to the diametral plane, it be now moved into the planes of symmetry which bisect the octants, and between the ditetragonal and ditrigonal axes; as the poles approach the plane the angle between the

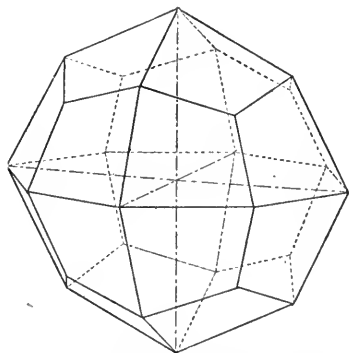

FIG. 76.—The Tetragonal Trisoctahedron, (hhl) .

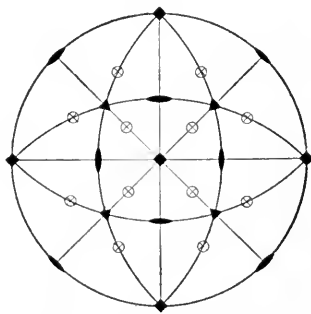

FIG. 77.—The Tetragonal Trisoctahedron.

normals constantly diminish until the plane is reached, when it becomes 0, Fig. 73 *a*, and the angle between the faces they represent is 180° . Thus two faces, *b* and *c*, *a* and *e*, of the most general form will coalesce, producing a form bounded by 24 four-sided faces, Fig. 76, having three faces entirely within each octant. Four faces are grouped around the ditetragonal, three around the ditrigonal, and four around the didigonal axes. In this form, also, the solid angles between faces will vary with the value of *n*, yielding a series. The tetragonal trisoctahedron may be produced by replacing each face of the octahedron with three tetragonal faces.

IV. Trigonal Trisoctahedron; $a : a : na$; (hhr) , Fig. 78.

Let the poles of the most general form now be moved till they lie in the plane of symmetry between the ditrigonal and didigonal axes, Fig. 73 *a*. Again two faces, *a* and *b*, *a'* and *b'*, of the most general form will fall in one plane, producing still a third form bounded by 24 faces, Fig. 78; each face is an isosceles triangle with its base lying in the diametral plane. Eight of its faces, Fig. 79, are grouped around the ditetragonal, three around the ditrigonal, and the didigonal axes bisect the base of the triangular face. As in the preceding forms the solid angles vary with the value of *n*, producing a series of trigonal trisoctahedra.

V. Hexahedron; $a : \infty a : \infty a$; (001), Fig. 80.

In the previous cases the poles of the most general form have been moved into one of the sides of the triangle, in which it lies; there are still three possibilities, the three corners of the triangle. Let

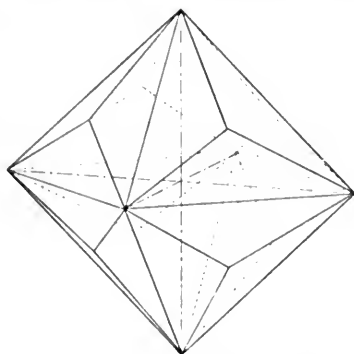

FIG. 78. — The Trigonal Trisoctahedron, (hhr).

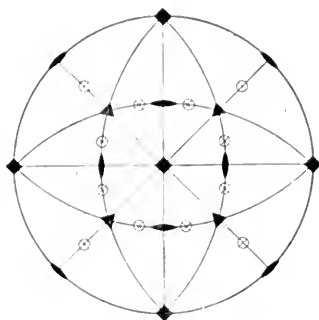

FIG. 79. — Trigonal Trisoctahedron, (hhr).

it now be moved, Fig. 73 a, to coincide with the ditetragonal axis, when all eight faces of the most general form grouped around this, as b, b', c, etc., will fall in one plane, producing a form with six faces, the **hexahedron**, or cube, Fig. 80. Each face will cut one axis and is parallel to the other two. The ditetragonal axes will

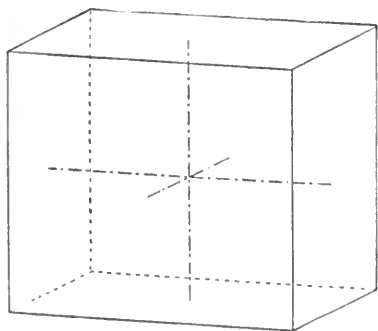

FIG. 80. — The Hexahedron, (100).

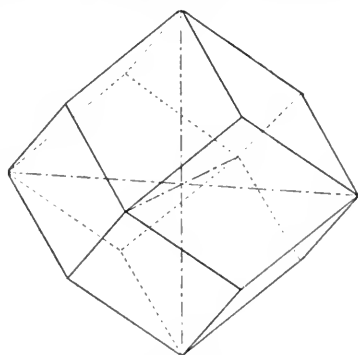

FIG. 81. — The Rhombic Dodecahedron, (110).

end in the center of the faces, the ditrigonal in the corners, and the didigonal will bisect the edges. The angles between the faces are fixed at 90° , there is but one hexahedron and not a series. It is therefore termed a fixed form.

VI. Rhombic Dodecahedron; $a : a : \infty a$; (110), Fig. 81.

If the pole is now moved to the didigonal axes, Fig. 73 *a*, four faces *a*, *a'*, *b*, *b'*, will fall in one plane, producing a form with 12 rhombic faces, Fig. 81. The faces are grouped four around the ditetragonal axes, three around the ditrigonal, and the didigonal axes bisect the edges. There is but one rhombic dodecahedron with the angles fixed at 120°. It is also a fixed form.

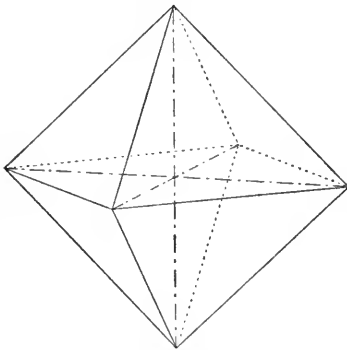

FIG. 82. — The Octahedron, (111).

VII. Octahedron; $a : a : a$; (111), Fig. 82.

The seventh and last possible form in this type is where the pole is moved to the ditrigonal axes, when the six faces *a*, *b*, *c*, *e*, etc., of the general form grouped around this axis will fall in one plane, producing a form bounded by eight equilateral triangular faces, Fig. 82. Four faces are grouped around the ditetragonal axes, the ditrigonal axes terminate in the center of the face, and the didigonal axes bisect the edges. All dihedral angles of the regular octahedron are fixed at 70° 31' 42''; it is therefore a fixed form.

Relation of the Seven Forms

When any one of the 48 triangular segments into which the planes of symmetry divide space is considered, Fig. 83, it has been shown that the pole $na : a : ma$, the hexoctahedron, may be located anywhere within the area, and when it approaches the sides or angles, either one or both of the variables *m* and *n* approach their limiting values 1 and ∞ . If the pole approaches one of the sides, only one of the variables approached its limit, or the two variables are of the same value. The hexoctahedron, tetrahexahedron, tetragonal trisoctahedron, and the trigonal trisoctahedron, are known as the variable forms, since their parameters contain a variable. The position of the pole of

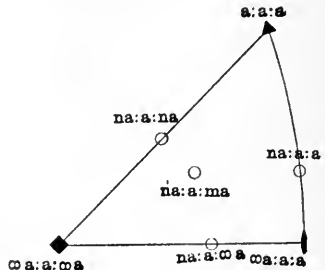

FIG. 83.

any one form on the triangle will depend upon the value of the variable. As the pole of any of the variable forms approaches the angle of the triangle, both variables approach their limits; and upon reaching their limits the pole assumes the position of one of the axes of symmetry, and as there is only one point in the angle of the triangle, therefore there is only one possible form of the hexahedron, rhombic dodecahedron, or octahedron, and they are known as the fixed, or limiting forms. All substances crystallizing in these forms must have the same angle.

In each type there are always seven possible forms. The most general form is represented by the area of the triangle; and as the number of points which the pole of the face may occupy is unlimited, there are therefore innumerable individuals forming a series. The three sides of the triangle each represents a series of variable forms, as here also there is a large number of points on each side between the angles, each of which may be occupied by the pole in turn. The three angles of the triangle represent the three fixed forms, as there is only one point in each of the three angles. The seven forms possible in each type are represented by the seven elements of the triangle, of which the three angles represent the three fixed forms, and the three sides and area represent the variable forms.

Combination of Forms

Crystals may present one form only, when the number of faces is very limited; more often they are combinations of two, three, or even all seven of the possible forms in the type, and in addition forms of the same series; in such cases the number of faces possible

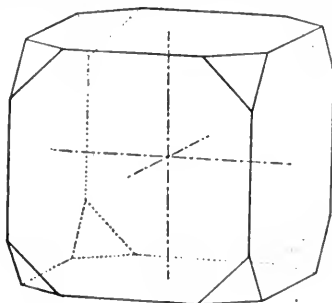

FIG. 84.

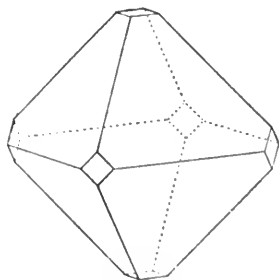

FIG. 85.

on a crystal is very large and their relation complex. Such complex crystals are rare in nature, for by far the larger number are

combinations of a few simple forms. The general appearance or habit is fixed by the simple form predominating in the combination. Figure 84 is a combination of a hexahedron and octahedron, the former predominating; Fig. 85 is the same combination with the latter predominating.

Examples crystallizing in the Type

Copper, forms (100) (110) (111) (410) (211) (531). Fig. 86.

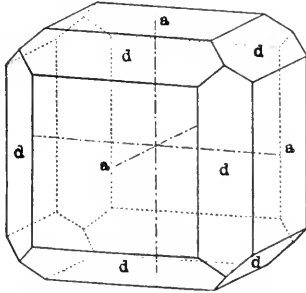

FIG. 86. — Combination of *a* (001) and *d* (110) on copper.

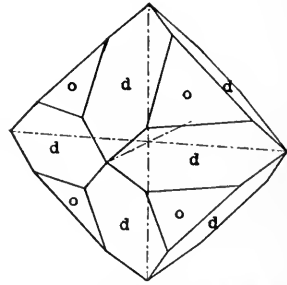

FIG. 87. — Magnetite, *a* (001) and *d* (110).

Lead, forms (100) (110) (111) (410) (550).

Silver, forms (110) (111) (310) (751).

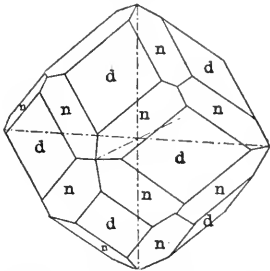

FIG. 88. — Garnet; Combination of *n* (221) and *d* (110).

Galena, PbS , forms (100) (110) (111) (221). Fig. 84.

Magnetite, Fe_3O_4 , forms (100) (110) (111) (210) (221) (432). Fig. 87.

Fluorite, CaF_2 , forms (100) (111) (421) (110) (211).

Analcite, $\text{NaAl}_3(\text{SiO}_3)_2, \text{H}_2\text{O}$, forms (100) (211) (575).

Garnet, forms (110) (111) (310) (221). Fig. 88.

CLASS, TETRAHEDRAL (DIAGONAL-FACED) HEMIHDRONS

TYPE 31, DITESSERAL POLAR

All forms of this type possess four ditrigonal polar axes, terminating in the center of the octants. The conditions surrounding one extremity of the axis are different from those at the other extrem-

ity, hence the term polar. The crystallographic axes are didigonal axes. The six planes of symmetry bisect the octants and pass through opposite edges of the cube, Fig. 89.

Symmetry, 4 ditrigonal polar axes, 3 didigonal axes, and 6 planes. There being no center of symmetry, the forms are not bounded by parallel faces.

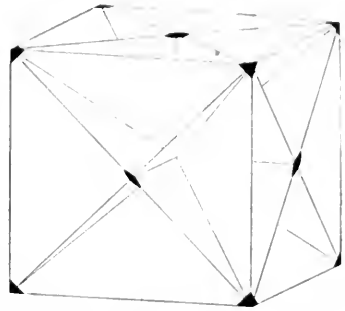

FIG. 89.—Diagram of Axes and Planes of Symmetry in Type 31.

Forms

I. **Hextetrahedron;** $\frac{na : a : ma}{2}$; $\kappa (hkl) \kappa (\bar{h}\bar{k}\bar{l})$.

In grouping the faces around the isometric axes so as to conform to the symmetry of any type, it is necessary to cut all extremities of the crystallographical axes with the same number of faces and at the same inclination, since the axes are interchangeable. If planes are grouped on the axes, fulfilling the symmetry of this type, the most general form will be bounded by 24 similar scalene triangles, Fig. 90; six faces are grouped around the ditrigonal,

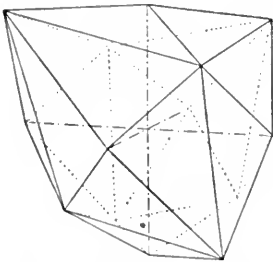

FIG. 90.—The Hextetrahedron, $\kappa (hkl)$.

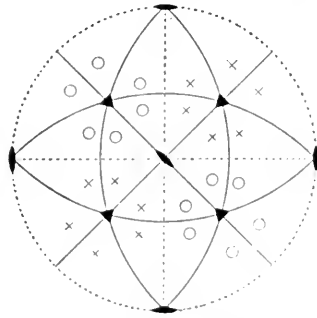

FIG. 91.—The Hextetrahedron, $\kappa (hkl)$.

four around the didigonal axes. The spherical projection, Fig. 91, shows that the poles (circles) in the northern hemisphere do not reflect those in the southern hemisphere (crosses); therefore the plane of projection is not a plane of symmetry. If this projection is compared with Fig. 73a, it will be seen that the poles of the hextet-

rahedron correspond to one half the poles of hexoctahedron. It is as if all the faces in alternate octants above and below were extended (Fig. 35, the shaded octants) until they inclosed space; the form produced would be the + hextetrahedron. When the unshaded faces are extended the - hextetrahedron is produced, congruent with the former by a revolution of 90° . In all hemihedrons there are + and -, or right and left forms, which may occur on crystals in combination, or independently. \pm forms are always congruent by a revolution.

Other forms of this type may be produced, as in the holohedral class, by moving the pole of the most general form to the sides and angles of the triangle in which it lies, yielding in all seven possible forms, some of which will be new forms; others will be of the same shape as the holohedral forms.

II. In Fig. 91, if all the poles be moved till they lie on the side of the triangles between the two didigonal axes, they will occupy the same position as, Fig. 75, the poles of the tetrahexahedron. The holohedral and hemihedral forms are of the same shape, but the symmetry of the two, caused by the character or arrangement of the molecules, will differ. Where an apparent holohedral form is found in combination with hemihedral forms, it must be considered as a hemihedron and will possess the lower type of symmetry.

The tetrahexahedron is reproduced by extending the faces which exist in alternate octants, as each face of the holohedral form extends in two octants, half in each; the half lying in the octants extended will reproduce the half in the adjacent octants. There are no + or - forms in those cases where the hemihedron assumes the holohedral shape.

III. Trigonal tristetrahedron; $\pm \frac{na : a : na}{2}$; κ (hhl) κ $\bar{h}\bar{h}l$.

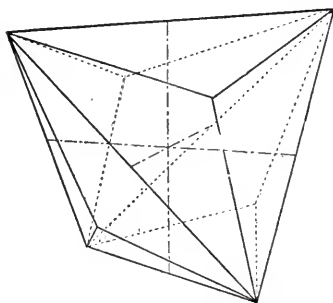

FIG. 92. — The Plus Trigonal Tristetrahedron.

If the poles be placed on the side of the triangle between the ditrigonal and didigonal axes, two will coincide, yielding a new form, the **trigonal tristetrahedron**, bounded by 12 similar isosceles triangles, Fig. 92. Three faces are grouped around one extremity of the ditrigonal axis and 6 around the other. The didigonal axes bisect the base of the triangular faces. This form may also be

considered as produced by the extension of alternate octants of the tetragonal trisoctahedron. There are congruent + and - forms.

IV. Tetragonal tristetrahedron; $\pm \frac{na : a : a}{2}$; $\kappa (hh\bar{1}) \kappa (h\bar{h}1)$.

Let the poles now be moved on the side of the triangle between the ditrigonal axes, when the **tetragonal tristetrahedron** bounded by 12 tetragonal faces will be produced, Fig. 93. Three faces are grouped around the extremities of the ditrigonal, four around the didigonal axes. This form may also be derived by extending alternate octants of the trigonal trisoctahedron.

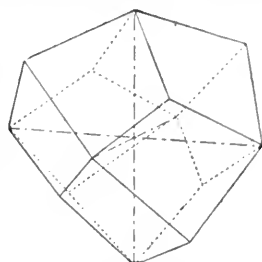

FIG. 93.—Tetragonal Tristetrahedron, $\kappa (221)$.

The four tetrahedral forms thus far considered are variable forms, as their angles will depend upon the value of the intercepts.

V. If the pole be placed on the didigonal axes, the hexahedron will be reproduced, as in type 32.

VI. If the pole be placed in the plane of symmetry midway between the ditrigonal axes, the rhombic dodecahedron will be reproduced; both hexahedra and rhombic dodecahedra may combine with tetrahedral forms.

VII. Tetrahedron; $\pm \frac{a : a : a}{2}$; $\kappa (111) \kappa (1\bar{1}\bar{1})$.

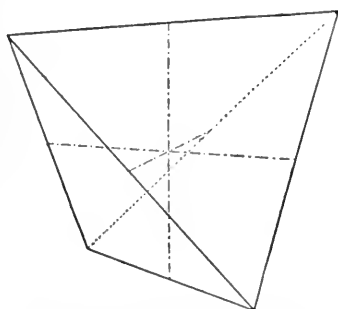

FIG. 94.—The Plus Tetrahedron, $\kappa (111)$.

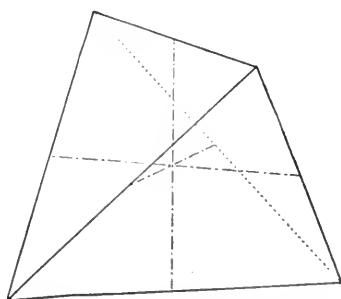

FIG. 94 a.—The Negative Tetrahedron, $\kappa (1\bar{1}\bar{1})$.

If the poles be placed on the ditrigonal axes, six faces will fall in the same plane, producing a form bounded by four equal equilateral triangles, the regular tetrahedron, Fig. 94. It may also be

considered as produced by the extension of alternate faces of the octahedron.

Combinations

Of the seven forms which may combine in the tetrahedral class, the tetrahexahedron, hexahedron, and rhombic dodecahedron are apparently holohedrons in shape. They can be distinguished from the latter when not in combination with tetrahedral forms only by special markings, striations, etch figures, or other physical properties, which indicate a symmetry of the lower type.

Crystal faces often contain striations, parallel to the edge of common combinations found represented on the crystals. They

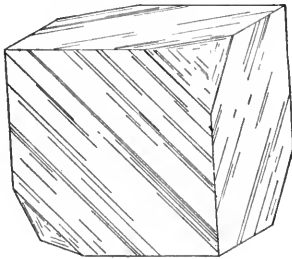

FIG. 95.

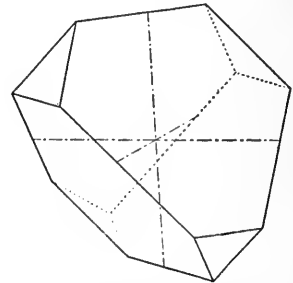

FIG. 96. — The Plus and Minus Tetrahedrons of Sphalerite.

are attributed to alternations of growth, in which the face is reduced to the minimum, and appear as a striation parallel to the common edge. Fig. 95 represents a combination of the hexahedron and tetrahedron in sphalerite. The striations on the hexahedral faces

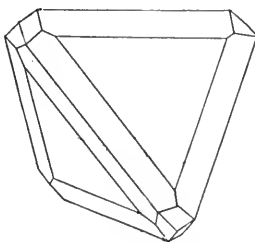

FIG. 97. — Combination of $\kappa(111)$, $\kappa(211)$, (110) on Tetrahedrite.

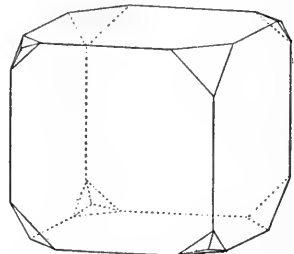

FIG. 98. — Combination of (100), $\kappa(111)$, $\kappa(211)$ on Boracite.

are traces of tetrahedral faces. It is to be noted that the striations on the cube faces are symmetrical to planes containing opposite

edges of the cube, which mark it as a hemihedral cube belonging to the tetrahedral type of symmetry, even if the tetrahedron did not truncate the corners.

Examples of minerals crystallizing in the type.

Diamond, C, $(\bar{1}\bar{1}1)$ (100) (321) (210) (320).

Sphalerite, ZnS, (100) (111) (110) (311) (331) (210). Fig. 96.

Tetrahedrite, $4\text{Cu}_2\text{S}$, Sb_2S_3 , (100) (110) $(\bar{1}\bar{1}1)$ (221). Fig. 97.

Boracite, (100) (110) (111) (410) (531) (221). Fig. 98.

CLASS, PYRITOHEDRAL (PARALLEL-FACED) HEMIHEDRONS

TYPE 30, TESSERAL CENTRAL

All forms of this type possess four trigonal axes ending in the center of the octants; three didigonal axes corresponding to the crystallographical axes; three planes, the diametral planes and a center of symmetry. All forms of the type are therefore bounded by pairs of parallel faces.

Symmetry.—4 trigonal axes, 3 didigonal axes, 3 planes and a center, Fig. 99.

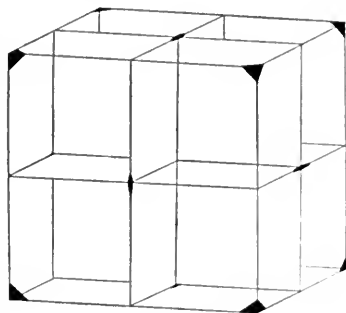

FIG. 99.

Forms

I. Diploid; $\pm \frac{na : a : ma}{2}$; $\pi (hkl) \pi (\bar{h}\bar{k}\bar{l})$

If planes be grouped on the axes to conform to the symmetry of the type, it will be found that if half of the faces of the hexocta-

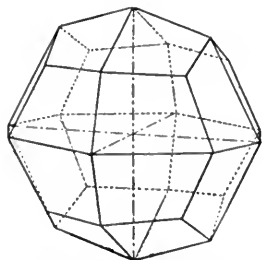

FIG. 100.—The Minus Diploid, $\pi (hkl)$.

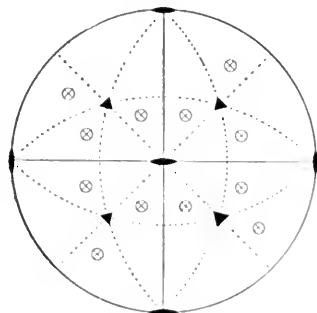

FIG. 100a.

hedron are selected, so that pairs taken intersecting in the diametral planes (Fig. 37, the shaded faces) are then extended, they will produce a new form, the diploid, Fig. 100, with 24 four-sided faces, three of which are grouped around the trigonal and four around the didigonal axes. Figure 100 *a* shows the symmetry and poles of the — form.

II. Pyritohedron; pentagonal dodecahedron $\pm \frac{na : a : \infty a}{2}$;
 π (hlo) π (h $\bar{l}o$).

When the pole is moved to the side of the triangle between the didigonal axes, and in the plane of symmetry, a new form will be produced, the pyritohedron, Fig. 101, bounded by 12 pentagonal faces.

Three faces are grouped around the trigonal axes, and the didigonal axes bisect the long edge between adjacent faces. The

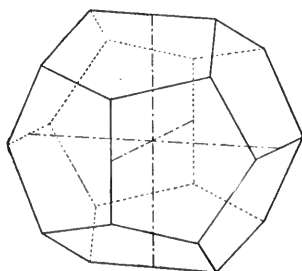

FIG. 101.—The Pyritohedron,
 π (hlo).

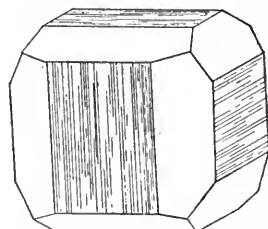

FIG. 102.—Pyrite: Combination of (100) and π (hlo).

pyritohedron may be considered as derived from the tetrahexahedron by extending alternate faces.

III. Other forms.

Other possible positions of the poles are identical in number and positions with the forms of type 32: Therefore the tetragonal trisoctahedron, trigonal trisoctahedron, hexahedron, rhombic dodecahedron, and octahedron may be found in combination with the diploid and pyritohedron. They also reproduce the same forms when the method of selection to form hemihedrons of this class is applied to them.

Combinations

Geometrical holohedral forms of this type must possess the pyritohedral symmetry. Pyrite, FeS_2 , crystallizes in all seven forms of

the type, but commonly in (111) (010) π (h10) with striations on the cube face, parallel to its edges, due to alternations of growth between the cube and pyritohedron, Fig. 102. These striations are parallel to the planes of symmetry which bisect the cube edges, and not, as in sphalerite, type 31, parallel to the planes which contain the edges and cross the face diagonally.

Other representatives of the type are smaltite, CoAs_2 ; cobaltite, CoAsS .

CLASS, PLAGIOHEDRAL (GYROIDAL) HEMIHEDRONS

TYPE 29, TESSERAL HOLOAXIAL

As the name implies, this type possesses all the axes, 3 tetragonal, 4 trigonal, 6 digonal, of the system, but no planes or center of symmetry.

Forms

I. Pentagonal icositetrahedron (didodecahedron) $r/1 \frac{na : a : ma}{2}$;
 τ (hkl) τ (khl).

If every other face of the hexoctahedron around the ditetragonal axis is extended, as indicated by the shaded faces of Fig. 39, the solid formed will have the symmetry of this type. It is bounded by 24 pentagonal faces, 4 of which are grouped around the tetragonal axes, 3 around the trigonal, and the digonal axes of symmetry bisect the edge between two faces. When the right upper face of the positive octant is extended, then the right pentagonal didodecahedron is produced, Fig. 103. If the left upper face is ex-

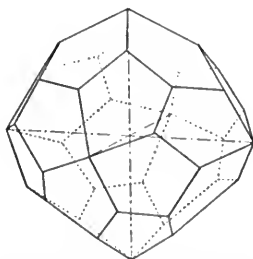

FIG. 103. — The Right Pentagonal Didodecahedron.

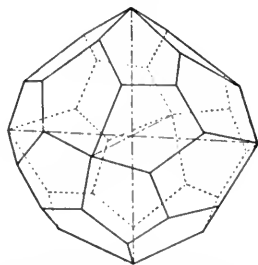

FIG. 104. — The Left Pentagonal Didodecahedron.

tended, the left pentagonal didodecahedron, Fig. 104, is produced. Figure 105 is a spherical projection of the right form. They differ from + and - hemihedra, as there is no way of revolving one into

a congruent position with the other; they are not superimposable; one is a mirror image of the other.

Such pairs of forms are enantiomorphous.

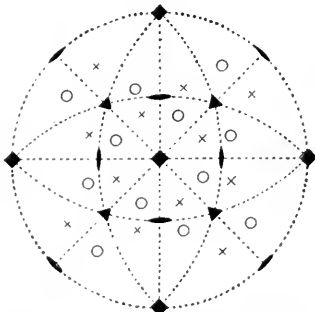

FIG. 105. — The Right Pentagonal Icositetrahedron.

As six forms of the type are in shape holohedrons, minerals which crystallize in the type are distinguished by a study of the symmetry of the etch figures; this is especially necessary as the occurrence of the most general form is always rare. Sylvite, KCl , occurs in combinations of the cube and octahedron, Fig. 106. Etch figures appear on the cube faces as shallow pits with square outline. The position of the square pits depends upon the symmetry of the point-system, as the type contains no planes of symmetry; they are so oriented on the cube that none of the possible planes which are traced on the cube face will cut them symmetrically.

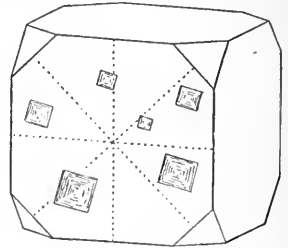

FIG. 106. — Diagram of Etch Figures on Sylvite.

Examples.

Cuprite, Cu_2O ; (111) (100) (110) (211) rarely in τ (hkl), from Cornwall, Eng.,

Ammonium Chloride NH_4Cl ; (111) (110) (100) τ (875).

TETARTOEDRAL CLASS TYPE 28, TESSERAL POLAR

Symmetry: crystals of this type must conform to 4 trigonal axes ending in the center of the octants; these four trigonal axes maintain their position in all five types of the isometric system and to three digonal axes corresponding to the crystallographic axes. They have no planes or center of symmetry.

Forms

Tetartohedral pentagonal dodecahedron; $\pm R, \pm L$ $\frac{na : a : ma}{2}$;
 $\kappa\pi(hkl), \kappa\pi(hkl), \kappa\pi(khl), \kappa\pi(khl)$.

The symmetry of the type requires but one quarter of the faces of the holosymmetric form. Figure 107 represents the poles of the + right tetartohedral pentagonal dodecahedron. The form is bounded by 12 irregular pentagonal faces, three of which are grouped around the trigonal axes; the digonal axes bisect an edge.

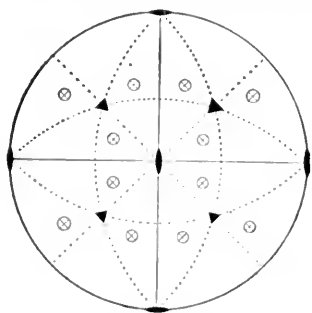

FIG. 107.—The Plus Right Tetartohedral Pentagonal Dodecahedron. *Tetartohedron.*

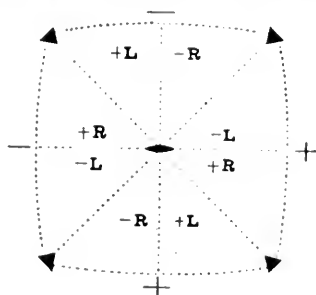

FIG. 108.

Figure 108 represents the 8 faces of the hexoctahedron grouped around the ditetragonal axis, which axis in the tetartohedral class is a digonal axis. Four tetartohedral pentagonal dodecahedra are possible. If the two faces + R are extended, the + right,

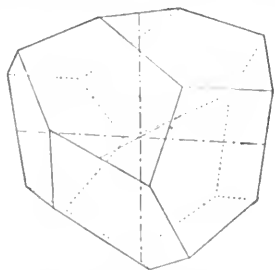

FIG. 109.—The Plus Right Tetartohedral Pentagonal Dodecahedron, $\kappa\pi(hkl)$.

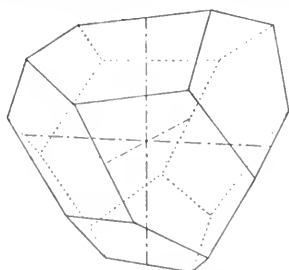

FIG. 110.—The Plus Left Tetartohedral Pentagonal Dodecahedron, $\pi\kappa(khl)$.

Fig. 109, pentagonal dodecahedron results; if + L are extended, the + left, Fig. 110; - R is the negative right, - L the negative left forms. \pm rights are congruent, for if the face + R is revolved

90° it is superimposed on $-R$, likewise \pm lefts are congruent, but the rights are enantiomorphic with the lefts, for in no way can the face $-R$ be revolved around the digonal axis to bring it into a congruent position with the face $+L$ or $-L$. There are always four tetartohedral forms. They may be derived by superimposing one hemihedral type of selection on another and extending the faces remaining, Fig. 41, page 27.

Other Forms

The six other possible forms of the type are derived by a consideration of the position of the poles in the triangle, Fig. 107:

Pole on the side between the digonal axes = + pyritohedron.

Pole on the side between the digonal and trigonal axes = \pm tetragonal tristetrahedron.

Pole on the side between trigonal axes = \pm trigonal tristetrahedron.

Pole on the digonal axes = hexahedron.

Pole on the trigonal axes = \pm tetrahedron.

Pole on the angle between the digonal axes = rhombic dodecahedron.

Combinations

Apparent holohedral and hemihedral forms of more than one type may be found combined on the same crystal; when this is observed, all forms must be considered as being of tetartohedral symmetry.

Examples: Minerals crystallizing in the type are rare.

Ullmannite from one locality crystallizes in pyritohedra and in tetrahedra from another, which would indicate that it is tetartohedral. There are a number of artificial salts, as barium nitrate, sodium chlorate, strontium nitrate, and sodium bromate, which crystallize in this type.

CHAPTER IV

TETRAGONAL SYSTEM

THE tetragonal system embraces all those crystals referable to three axes at right angles, two of which, the lateral axes, are equal and interchangeable, designated by the letter *a*. The third or vertical axis, designated by *c*, is not interchangeable with the lateral axes. The most general parameter of the system is $na : a : mc$, in which the value of *n* may vary from unity to infinity; *m* may vary from zero to infinity. With the *c* axis held vertical and one of the lateral axes in the plane of the paper, the other at 90° to it, the extremities are designated + or - as in the isometric system, the upper right octant being positive. Seven of the 32 types are included in the tetragonal system.

CLASS, TETRAGONAL HOLOHEDRAL (HOLOSYMMETRIC)

TYPE 27, DITETRAGONAL EQUATORIAL

Symmetry.—Crystals of this type possess one axis of ditetragonal symmetry, the *c* axis; four didigonal axes, two of which are

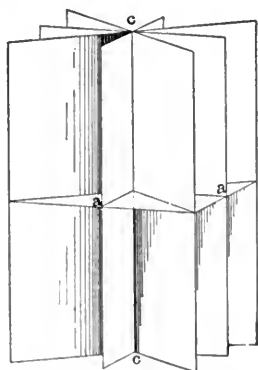

FIG. 111.—The Planes of Symmetry in Type 27.

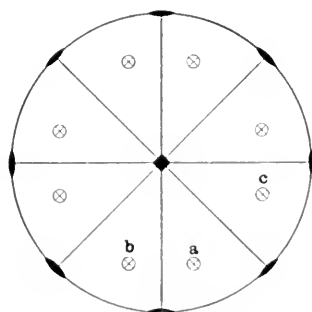

FIG. 112.—The Ditetragonal Pyramid.

the lateral axes; the other two, the intermediate axes, bisect the angle between the *a* axes. All four didigonal axes lie in one plane, the equatorial plane, at 90° to the vertical axis. There are five

planes of symmetry, Fig. 111, one of which is the equatorial plane; the other four intersect in the *c* axis and each contains one of the axes of symmetry lying in the equatorial plane. The five planes divide space into 16 equal (Fig. 112) triangular portions, eight above and eight below the equator. The largest number of faces possible upon any form of the tetragonal system will be 16.

Forms

I. Ditetragonal pyramid; $na : a : mc$; (hkl) .

When the values of *n* and *m* are between their limits, the pole of the face will fall within the area of the triangle, Fig. 112; there will be one face in each triangular space, yielding a form, the **ditetragonal pyramid**, Fig. 113, bounded by 16 scalene triangles (pyramid here includes the faces above and below the equator and are doubly pointed). It has eight faces grouped around the north and eight around the south pole or *c* axis; four faces grouped around the extremities of the didigonal axes. There is a series of ditetragonal pyramids, the shape of the face or the value of the interfacial angles of any one of which will depend upon the values of *n* and *m*.

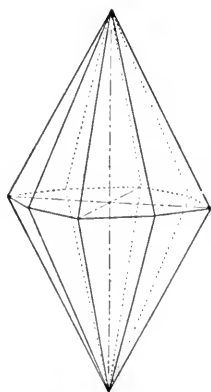

FIG. 113.—The Ditetragonal Pyramid.

II. Tetragonal pyramid of the first order; $a : a : mc$; (hhl) .

When the value of *n* is **unity**, its minimum limit, or if the pole in the spherical projection, Fig. 112, is moved until it coincides with the intermediate axes, then two adjacent poles of the most general form, as *a* and *c*, will combine, yielding a form bounded by eight isosceles triangles, Fig. 114, the tetragonal pyramid of the first order. Its eight polar edges are equal. The crystallographical axes terminate in a solid tetrahedral angle; this characterizes a pyramid of the first order; in pyramids of the second order the *a* axes bisect

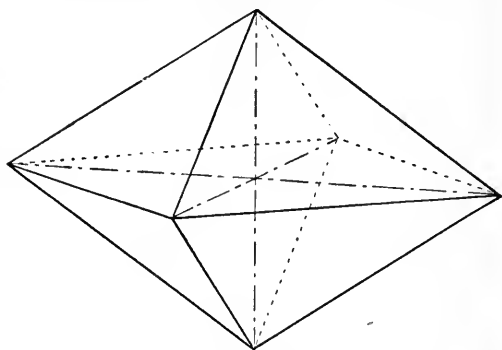

FIG. 114.—Pyramid of the First Order (111), of Cassiterite.

an edge. There is a series of pyramids of the first order, their acuteness and general appearance depending upon the value of m .

III. Tetragonal pyramid of the second order ; $a : \infty a : mc$; (hol).

When the value of n is ∞ , its maximum limit, or if the pole is moved to coincide with the crystallographical axes, then in the resulting form of eight faces the axes will terminate in the center of the equatorial edge, yielding a pyramid of the second order, Fig. 115. In shape this pyramid in no way differs from the pyramid of the first order, with which it becomes congruent by

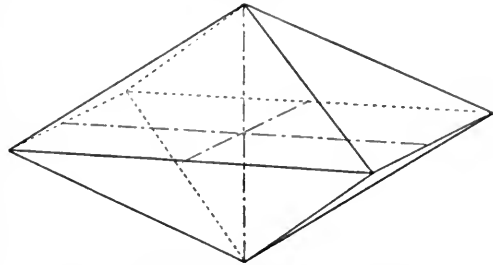

FIG. 115. — Pyramid of the Second Order, (101), of Cassiterite.

a revolution of 45° around the c axis. There is a series of pyramids of the second order, depending upon the value of m .

IV. Ditetragonal prism ; $na : a : \infty c$; (hko).

When the value of n is between its limits and m is infinity, or if the pole in the spherical projection is moved to the primitive circle between the extremities of the didigonal axes, the resulting form is the ditetragonal prism, Fig. 116. It is bounded by eight similar faces.

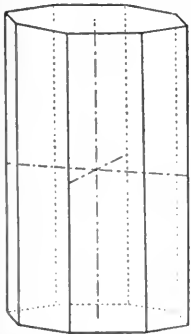

FIG. 116. — The Ditetragonal Prism, (210).

Each face will cut one of the lateral axes at unity, the other at a distance greater than unity, and will be parallel to the c axis; it will therefore be an open form extending to infinity unless terminated by combining with another form.

All prisms are open forms. There is a series of ditetragonal prisms, the value of the interfacial angles depending upon the value of n .

V. Tetragonal prism of the first order ; $a : a : \infty c$; (110).

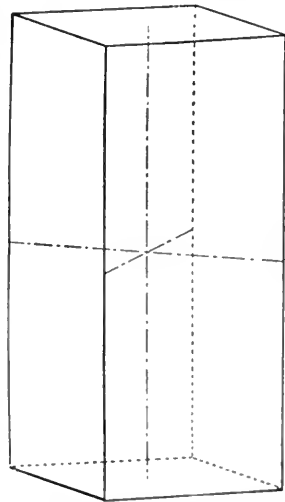

FIG. 117. — Prism of the First Order, (110).

When the value of n is unity and that of m is infinity, or let the pole be moved on the equatorial plane to coincide with the intermediate axes, then the resulting form is the tetragonal prism of the first order, Fig. 117. It will be bounded by four faces, cutting the c axis at infinity, the a axes at unity. The lateral axes terminate in the middle of the edges.

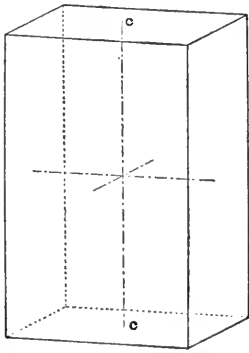

FIG. 118.—The Tetragonal Prism of the Second Order.

VI. Tetragonal prism of the second order; $\infty a : a : \infty c$; (010).

When the value of both n and m is at infinity, their maximum limit, or if the pole be moved in the equatorial plane to coincide with the crystallographic axes, then a rectangular prism results, the tetragonal prism of the second order, which in shape differs in no way from the prism of the first order except the a axes terminate in the center of the faces. It becomes congruent with the first order prism by a revolution of 45° around the c axis, Fig. 118.

VII. Basal pinacoid; $\infty a : \infty a : c$; (001).

The only possible position of the pole remaining is when it coincides with the c axis, when all eight faces above the equatorial plane will form one face and all the faces below will fall in one plane, yielding a form of two faces, the tetragonal base or basal pinacoid which extends to infinity on all sides, Fig. 118, *c*. All pinacoids cut but one axis and are parallel to the other two; in combination with prisms they inclose space. The fixed forms of the tetragonal system are the base and the prisms of the first and second orders; these correspond to the fixed forms of the isometric system, as do also the position of their poles in the triangle, viz., the corners or angles; as here there is evidently only one position for the pole, there is only one form possible.

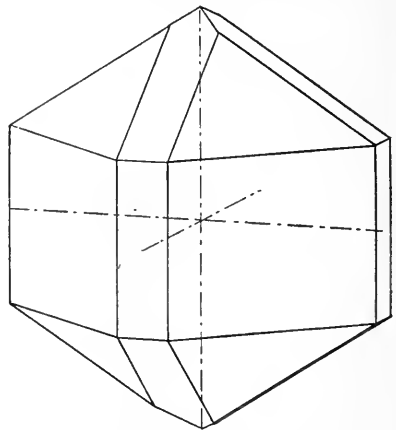

FIG. 119.—Combination of (111) (101) (110) (100) of Cassiterite.

Combinations.—The pyramids and prisms of the first and second orders truncate each other's edges symmetrically; Fig. 119 represents these four forms of cassiterite. Several members of a series of a variable form may occur in combination with the fixed forms, Fig. 120, Zircon.

Examples of minerals crystallizing in the ditetragonal equatorial:

Cassiterite, SnO_2 ; (110) (100) (310) (111) (101).

Zircon, ZrSiO_4 ; (110) (100) (111) (331) (311).

Rutile, TiO_2 ; (110) (100) (310) (111) (101).

Vesuvianite, $\text{Ca}_6(\text{Al, OH})\text{Al}_2(\text{SiO}_4)_5$; (100) (110) (310) (210) (001).

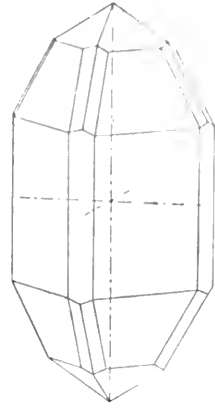

FIG. 120. — Combination of (111) (331) (311), (110) and (010) in Zircon.

CLASS, SPHENOIDAL (DIAGONAL-FACED) HEMIHEDRONS

TYPE 26, DITETRAGONAL ALTERNATING

Symmetry.—Crystals of this type possess a ditetragonal alternating axis, the c axis; two digonal axes, the a axes; and two planes of symmetry intersecting in the c axis and each containing one of the intermediate lateral axes; Fig. 121 represents the symmetry of the type.

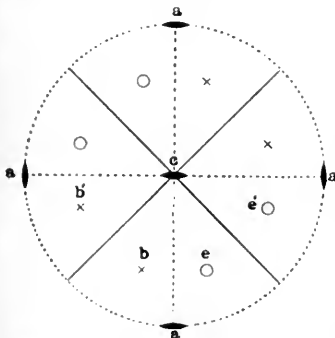

FIG. 121. — Type 26: Ditetragonal alternating.

This class of hemihedrons in the tetragonal system corresponds to the tetrahedral class in the isometric system and may be considered as derived from the holohedral forms by extending all the faces in alternate octants, Fig. 122; the shaded faces when extended will produce a — form as drawn.

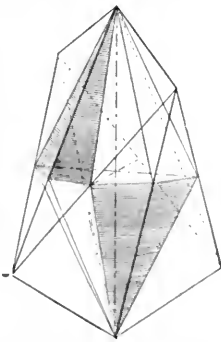

FIG. 122. — The Minus Scaleno-hedron κ (hkl).

I. Tetragonal scalenohedron; $\pm \frac{na : a : mc}{2}$; $\kappa (hkl) \kappa (h\bar{k}l)$.

This form is bounded by eight similar scalene triangles, Fig. 123, four of which are grouped around each extremity of the *c* axis, with the edges lying in the planes of symmetry. The lateral axes terminate in the middle of an edge. There are + and - forms which become congruent by a revolution of 90° around the *c* axis.

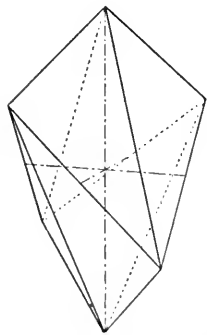

FIG. 123.—The Plus Sphenoid $\kappa (121)$.
Scalenohedron

II. Sphenoid; $\pm a : a : mc$; $\kappa (hhl) \kappa (h\bar{h}l)$.

When the pole is in the plane of symmetry represented by the full lines, Fig. 121, two faces of the scalenohedron will fall in one plane, as *e* and *e'* and *b*, *b'*, and the form will be bounded by four isosceles triangles, Fig. 124, producing the tetragonal sphenoid of the first order in which the

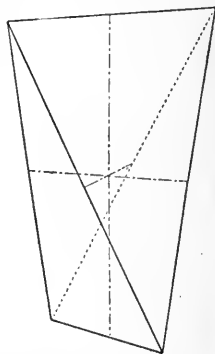

FIG. 124.—The Plus Tetragonal Sphenoid of the First Order, $\kappa (111)$.

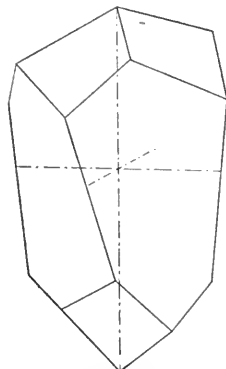

FIG. 125.—Combination of (122) and (772) of Chalcopyrite.

here, also, they must be considered as of lower symmetry, which will be recognized by their combination with the two new forms of the type, or by their striations and etch figures.

lateral axes bisect the four equal edges. The *c* axis bisects the remaining two edges. This form may also be considered as derived from the tetragonal pyramid of the first order by extending alternate faces above and below until they inclose space.

III. Other forms of the type. — All other positions of the pole will in turn produce the holohedral shapes of type 27, here as in the isometric system;

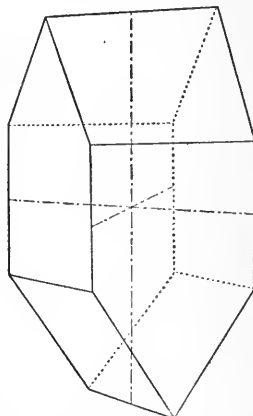

FIG. 126.—Chalcopyrite: Combination of (111) (110).

The possible forms to be found in combination in this type are:

The positive and negative tetragonal scalenohedrons, κ (hkl),

κ ($h\bar{k}l$).

The positive and negative sphenoids of the first order, κ (hhl),

κ ($h\bar{h}l$).

The pyramid of the second order, (ohl).

The ditetragonal prism, (hko).

The prism of the first order, (hho).

The prism of the second order, (oho).

The basal pinacoid, (oor).

Examples of minerals crystallizing in the type.

Chalcopyrite, $FeCuS_2$; (111) ($\bar{1}\bar{1}$) (122) (772). Figs. 125 and 126.

CLASS, HOLOHEDRAL HEMIMORPHIC

TYPE 25, DITETRAGONAL POLAR

Hemimorphic forms may be considered as derived from an equatorial form by the suppression of all the faces around one extremity of the c axis and the development of those around the opposite extremity, as an independent form, or if the equatorial form is cut along the equatorial plane, it will yield an upper hemiform and lower hemiform.

Symmetry. — All the elements of symmetry in the equatorial plane are lost, namely the four axes, the equatorial plane, and the center. The type is symmetrical in regard to a ditetragonal axis, the c axis and four planes of symmetry intersecting in the c axis, Fig. 127.

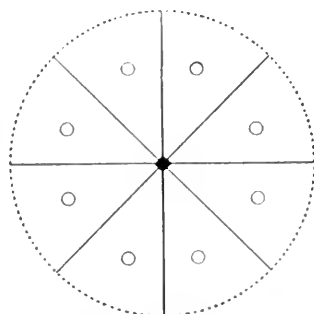

FIG. 127. — Type 25: Ditetragonal Polar.

Forms

Each pyramid of the ditetragonal equatorial type yields an upper and lower hemipyramid, each of which is independent. The basal pinacoid is also divided into upper and lower forms.

The possible forms to combination in this type are therefore:

The upper and lower ditetragonal pyramid; $u/1 \frac{na : a : ma}{2}$;
 (hkl) ($h\bar{k}l$).

The upper and lower pyramid of the first order; $u/1 \frac{a : a : mc}{2}$;
 (hhl) (hh \bar{l}).

The upper and lower pyramid of the second order; $u/1 \frac{\infty a : a : mc}{2}$;
 (ohl) (oh \bar{l}).

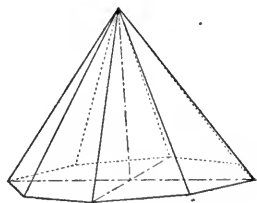

FIG. 128.—The Upper Ditetragonal Hemipyramid.

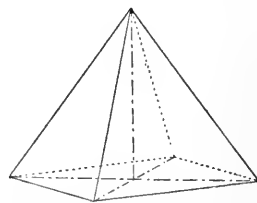

FIG. 129.—The Upper Hemipyramid of the First Order.

The ditetragonal prism; $na : a : \infty c$; (hko).

The prism of the first order; $a : a : mc$; (110).

The prism of the second order; $\infty a : a : \infty c$;
 (010).

The upper and lower basal pinacoid;
 $u/1 \frac{\infty a : \infty a : c}{2}$; (001) (00 $\bar{1}$).

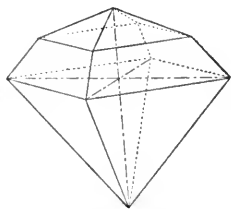

FIG. 130.—Silver Fluoride, AgF, H₂O; Combination of (111), (11 $\bar{1}$) (113).

Examples. — There are as yet no minerals known to crystallize in this type, but several organic and artificial salts belong here. Fig. 130 represents a crystal of silver fluoride, AgF, H₂O; with (111) (11 $\bar{1}$) (113) in combination.

CLASS, PYRAMIDAL (PARALLEL-FACED) HEMIHEDRONS

TYPE 24, TETRAGONAL EQUATORIAL

Symmetry. — Crystals of this type have an axis of tetragonal symmetry, the *c* axis; one plane, the equator, and a center, Fig. 131.

The forms may be considered as derived from the ditetragonal equatorial type by extending alternate pairs of faces which intersect in the equator, as is shown in Fig. 132, where the shaded faces when extended produce the — third order pyramid, Fig. 133.

Forms

I. Tetragonal pyramid of the third order; $\pm \frac{na : a : mc}{2}$; $\pi(hkl)$

$\pi(h\bar{k}l)$.

The faces represented by the poles in Fig. 131 form a pyramid similar in shape to the tetragonal pyramids of the first and second orders, differing only in that the lateral axes terminate in the equatorial edge between the tetrahedral angle and the middle.

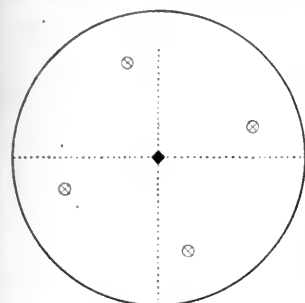

FIG. 131.—Type 24: Tetragonal Equatorial.

A diagram of the equatorial plane is represented in Fig. 134; aa is the pyramid of the first, ee is the pyramid of the second order, both being fixed forms; ab is the ditetragonal pyramid, a variable form lying between the fixed forms as its limiting forms; the dotted line represents the extension of one half of the faces, as ab to d , where it intersects at

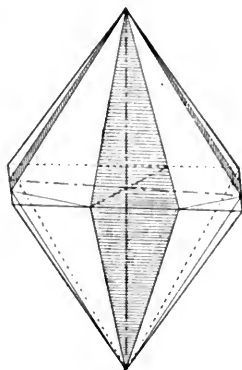

FIG. 132.

the pyramid of the first, ee is the pyramid of the second order, both being fixed forms; ab is the ditetragonal pyramid, a variable form lying between the fixed forms as its limiting forms; the dotted line represents the extension of one half of the faces, as ab to d , where it intersects at

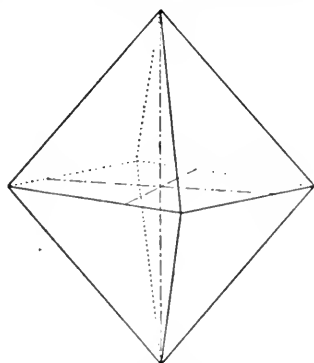

FIG. 133.—Pyramid of the Third Order of Scheelite, $\pi(313)$.

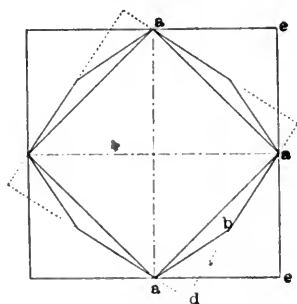

FIG. 134.

90° with the extension of the alternate face ad ; note that the axes in this pyramid terminate not in the angle, nor in the middle of the edge, but at a point on the edge somewhere between them. This diagram will represent the relation of the prisms equally well.

II. Tetragonal prism of the third order; $\pm \frac{na': a: \infty c}{2}$; $\pi(hko)$
 $\pi(\bar{h}\bar{k}o)$.

If the pole be placed on the primitive circle in an asymmetric position in the octant, or if every other face of the ditetragonal

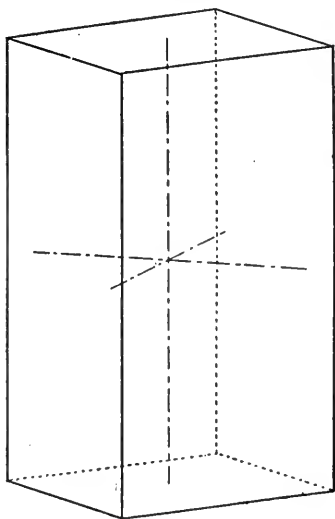

FIG. 135. — Prism of the Third Order of Stolzite, $\pi(340)$.

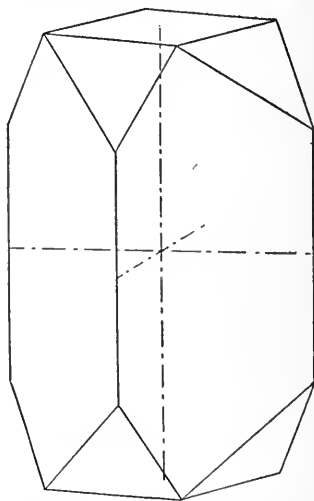

FIG. 135 a. — Combination of the First Order Prism with the Third Order Pyramid.

prism is extended, a new form will result, the tetragonal prism of the third order, Fig. 135, similar in shape to the 1st and 2d order prisms, except the lateral axes end in the face between the center of the face and the middle of the edges.

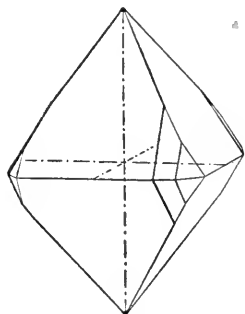

FIG. 136. — Combination of (101) (111) and (313) of Scheelite.

All other positions of the pole will yield holohedral shapes.

The possible forms in combination will therefore be the —

Positive and negative pyramids of the 3d order, $\pi(hkl)$ $\pi(\bar{h}\bar{k}\bar{l})$.

Tetragonal pyramid of the 1st order, (hhl) .

Tetragonal pyramid of the 2d order, (hol) .

The positive and negative prism of the 3d order $\pi(hko)$, $(\bar{h}\bar{k}o)$.

Tetragonal prism of the 1st order, (hho) .

Tetragonal prism of the 2d order, $(oh\bar{o})$.

Basal pinacoid, (001) .

Examples. — In combinations the two new forms, the 3rd order pyramid and prism will give the crystals an asymmetric appearance as in Fig. 135 *a*.

Examples. — Scheelite; CaWO_4 : (101) (111) (313). Fig. 136.

CLASS, TETRAGONAL TRAPEZOHEDRAL (PLAGIOHEDRAL) HEMI-HEDRONS

TYPE 23, TETRAGONAL HOLOAXIAL

Symmetry. — As the name implies, this type has all the axes of symmetry of the tetragonal system, but no planes or center. The *c* axis is a tetragonal axis and the lateral and intermediate axes are digonal axes of symmetry. As in all holoaxial types, there are right and left enantiomorphic forms.

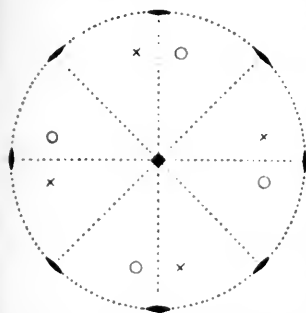

FIG. 137. — Type 23: Tetragonal Holoaxial.

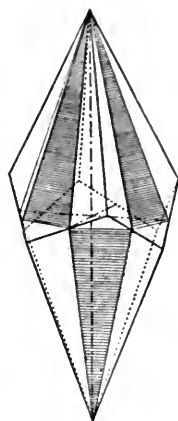

FIG. 138.

Forms

I. Tetragonal trapezohedron; $r/1 \frac{na : a : mc}{2}$;
 $\tau(hkl) \tau(khl)$.

If alternate faces of the ditetragonal pyramid around the north pole, represented by circles in Fig. 137 and shaded in Fig. 138, and faces alternating with these around the south pole, represented by + in Fig. 137, are extended, the right trapezohedron, Fig. 139, will result; if the unshaded faces of Fig. 138 are extended, the left trapezohedron will result, Fig. 139 *a*.

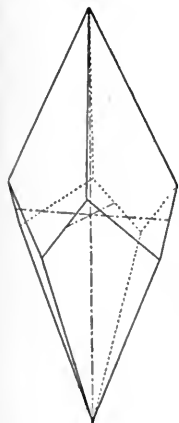

FIG. 139. — The Right Tetragonal Trapezohedron.

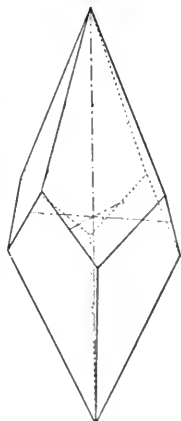

FIG. 139 *a*. — The Left Tetragonal Trapezohedron, $\tau(212)$.

ity of the *c* axis. The equator is represented by eight zigzag edges. The lateral axes bisect opposite edges.

II. Other forms. — All other positions of the poles will yield holohedral shapes. The trapezohedron is the only new form of the type, and it has never been found on a crystal. All substances crystallizing in this type have been placed here as a result of a study of their etch figures.

Forms possible to combine in the type are :

The right and left tetragonal trapezohedron, $\tau(hkl) \tau(khl)$.

The tetragonal pyramid of the first order, (hhl) .

The tetragonal pyramid of the second order, (ohl) .

The ditetragonal prism, (hko) .

The tetragonal prism of the first order, (hho) .

The tetragonal prism of the second order, (oho) .

The tetragonal base, (001) .

Examples. — There are no minerals of this type. The artificial nickel sulphate, $NiSO_4 \cdot 6 H_2O$, is placed here, also the sulphate of strychnine.

CLASS, TETRAGONAL SPHENOIDAL (TETARTOHEDRAL)

TYPE 22, TETRAGONAL ALTERNATING

The *c* axis in this type is a tetragonal alternating axis; there is no plane or center of symmetry. The forms of the type may be considered as derived from the holohedral forms by an extension of one quarter of the faces selected as illustrated in Fig. 140, which also shows the alternating character of the *c* axis.

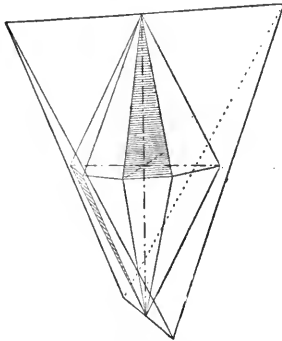

FIG. 140. — The Plus Left Tetragonal Sphenoid of the Third Order.

I. Sphenoid of the third order; $r/l \pm \frac{na : a : mc}{4}$; $\pi\kappa(hkl)$, $\pi\kappa(khl)$, $\pi\kappa(h\bar{k}l)$, $\pi\kappa(k\bar{h}l)$.

The faces represented by the poles of Fig. 141 produce the + R sphenoid of the third order, Fig. 142. The + L form is shown in Fig. 140, in its relation to the ditetragonal pyramid, where the four faces selected include the left-hand face of the + octant. There are four sphenoids of the third order possible, bearing the same relation to each other as in the tesseral polar type. The lateral

axes terminate asymmetrically in the face, on a line connecting the middle points of the four equal edges.

I. Sphenoid of the second order; $\pm \frac{a : a : mc}{2}$; $\pi\kappa(hol)$, $\pi\kappa(ohl)$.

When the poles of Fig. 141 are moved into the diametral planes, the + right and - left sphenoids will fall in one form, the + sphenoid of the second order, Fig. 142, in which the lateral axes

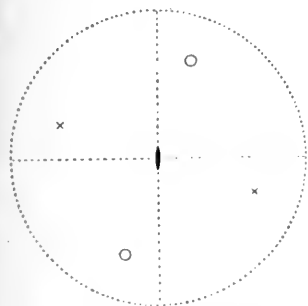

FIG. 141.—Type 22: Tetragonal alternating.

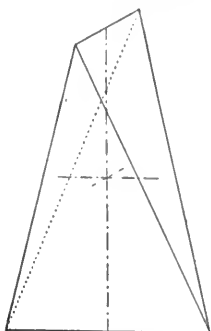

FIG. 142.—The Tetragonal Sphenoid of the Second Order.

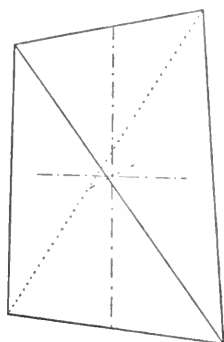

FIG. 142 a.—The Plus Right Tetragonal Sphenoid of the Third Order.

terminate in the central point of the line joining the middle of the four equal edges. Sphenoids of the second order may be considered as derived from the tetragonal pyramid of the second order by extending alternating faces above and below.

II. Other forms. — No new forms are produced by the other possible positions of the poles. Forms possible to combine in the type are:

\pm right and \pm left sphenoids of the third order, $\pi\kappa(hkl)$, $\pi\kappa(khl)$, $\pi\kappa(h\bar{k}l)$, $\pi\kappa(k\bar{h}l)$.

\pm sphenoid of the second order, $\kappa(ohl)$, $\kappa(hol)$.

\pm sphenoid of the first order, $\kappa(hhl)$, $\kappa(\bar{h}\bar{h}l)$.

\pm prism of the third order, $\pi(hko)$, $\pi(kho)$.

Prism of the second order, (oho) .

Prism of the first order, (hho) .

Basal pinacoid, (001) .

Example. — There is yet no representative of this type, either among minerals or artificial compounds.

CLASS, HEMIHEDRAL HEMIMORPHIC

TYPE 21, TETRAGONAL POLAR

Symmetry. — There is one axis of tetragonal symmetry; all the symmetry of the equatorial plane is lost. This type is related to the tetragonal equatorial in the same way as the ditetragonal polar is to the ditetragonal equatorial, Fig. 143.

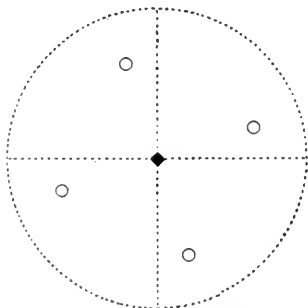

FIG. 143. — Type 21: Tetragonal Polar.

Forms

1 Tetragonal hemipyramid of the third order, $u/1 \frac{na : a : mc}{2}$; $\pi(hkl)$.

The tetragonal pyramid of the third order yields the only new forms of the type, the positive, Fig. 144, and negative upper and lower hemipyramids of the third order.

Forms possible to combine in the type are:

\pm upper and lower hemipyramids, of the third order, $\pi(hkl)$
 $\pi(khl)$, $\pi(hk\bar{l})$, $\pi(kh\bar{l})$.

Upper and lower hemipyramids of the second order, (ohl) , $(oh\bar{l})$.

Upper and lower hemipyramids of the first order, (hhl) , $(hh\bar{l})$.

\pm prisms of the third order,
 $\pi(hko)$, $\pi(kho)$.

Prism of the second order, (oho) .

Prism of the first order, (hho) .

Basal pinacoid, (001) , $(00\bar{1})$.

Examples. — Wulfenite, $PbMoO_4$, (111) $(11\bar{1})$ (001) (430) , Fig. 145.

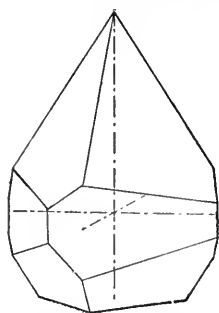

FIG. 145. — Wulfenite, (111) $(11\bar{1})$ (001) (430) .

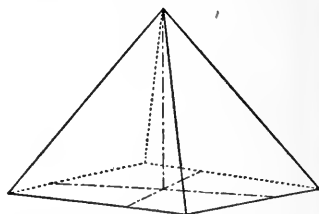

FIG. 144. — The Upper Hemipyramid of the Third Order, $\pi(hkl)$.

Etch figures. — In the seven types of the tetragonal system it will be noted that two forms, the prisms of the first and second orders, are common to all.

They are of the same shape and possess the same number of faces in each type; and in external appearance the prism of one type is not to be distinguished from that of another. The same condition exists in the case of the cube and rhombic dodecahedron in the five

types of the isometric system. While outwardly these seven prisms of the first order are exactly alike, yet inwardly they all possess their distinctive symmetry. The physical properties are distributed on the face of each prism in accord with, and they conform to, the symmetry of the type. The seven prisms of the first order will differ then in their symmetry.

When a solvent is applied to a crystal face or a natural crystalline surface, as a cleavage surface, the crystal will not pass into solution equally or with the same speed in all directions. The rapidity with which molecules pass into solution or are torn off from the crystalline network will depend upon the symmetry of the network. The solvent's action will not act evenly all over the surface, but will start at points scattered over the crystal face; and solution will begin at each one of these points as a nucleus or center, the molecules

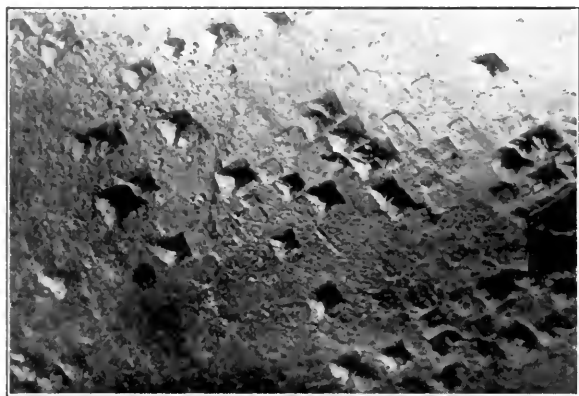

FIG. 146.—Photograph of Etch Figures on Halite, enlarged Five Diameters.

going into solution one after the other, with a speed that varies with the direction. If the solvent's action is stopped after a very short time and the crystalline surface is examined, in many cases, if the concentration and character of the solvent has been favorable and it has not been allowed to act too long, the surface will be peculiarly pitted. All of these pits or **etch figures** will be of the same shape on all faces of the same crystal form. They are bounded by straight or slightly curved lines and are of the nature of negative or reëntrant crystals, with their equivalent faces and axes arranged parallel, as is shown in Fig. 146. These etch figures may be produced by plunging a crystal into a solvent for a very short time, as they are the result of the first action of the solvent on the crystal face.

If solution is allowed to continue for a longer time, the outlines of the individual pits will meet and the face is then often covered with characteristic hillocks, representing points where the walls of

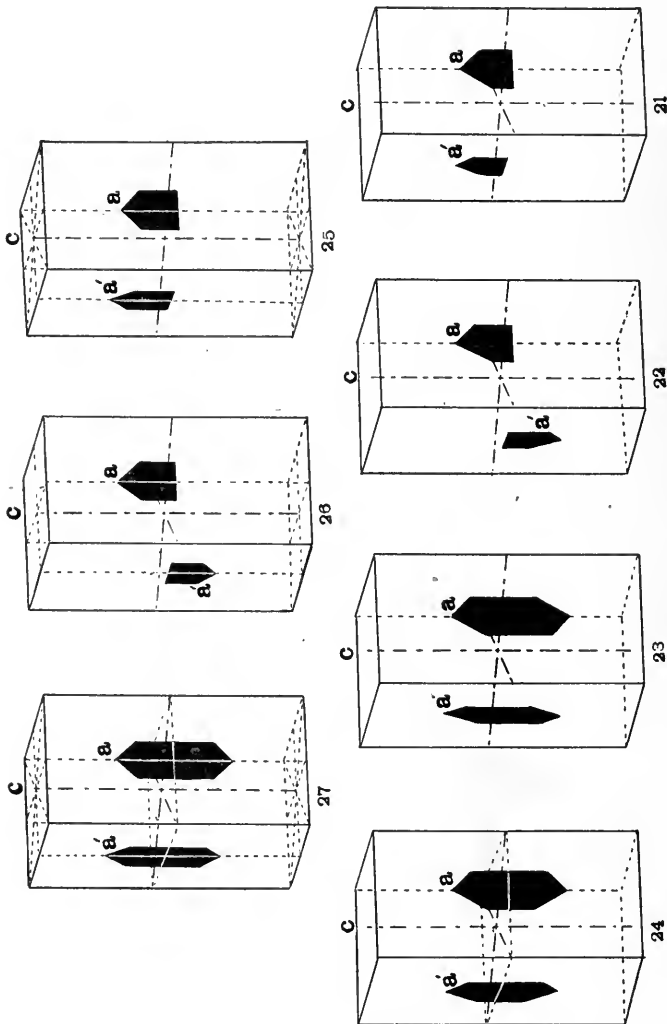

FIG. 146 a.

the etch figures have not as yet joined. The sides of the etch figures represent possible crystal faces, or more correctly vicinal faces, and they therefore reflect and conform to the symmetry of the face. Their shape will depend upon the chemical compound, the

strength and character of the solvent, as well as upon the crystal form etched; but, however produced, if produced under like conditions, the etch figures on all faces of any one form will be alike and conform to the symmetry of the face. Etch figures are therefore one of the most reliable means of determining the symmetry of any crystal face, and often decide the type to which a crystalline compound will belong when the crystal forms or combination of forms fail, and when the most general or distinctive form of the type is absent. Nickel sulphate, $\text{NiSO}_4 \cdot 6 \text{H}_2\text{O}$, has been placed in the tetragonal holoaxial type from the symmetry of its etch figures alone, while the most general or distinctive form of this type, the tetragonal trapezohedron, has never been observed on any crystal, and from the combination of forms alone it might belong to type 27, ditetragonal equatorial, or to type 24, the tetragonal equatorial. As an illustration of the method of determining the symmetry of apparently holohedral hemihedrons, Fig. 146 *a* represents the seven tetragonal prisms of the first order, with diagrammatic etch figures on each, conforming to the symmetry of the face in each of these seven possible prisms in the tetragonal system. The planes of symmetry where they cross the prism face are represented by dotted lines and where they cross the etch figure by a white line. In 27, the ditetragonal type, the prism face is symmetrical to two planes of symmetry, the vertical and equatorial planes and a center of symmetry. The shape of the etch figures on this face *a*, as indicated, must be symmetrical to planes parallel to these two planes and an axis of symmetry; furthermore, when the etch figure *a* is revolved 90° about the vertical axis *c*, it must become congruent with the etch figures, as *a'*, on the adjacent prism face of the same form. If all these conditions are fulfilled, then the prism is of type 27.

In type 26, the ditetragonal alternating, where the prism face is crossed by the vertical plane of symmetry only and the equatorial plane of symmetry is absent, the etch figures will be of a different shape, as represented, from those on the prism of type 27. They will be without an axis of symmetry, but will be symmetrical to the vertical plane; and when revolved 90° around the vertical axis *c* and reflected over the equatorial plane, they will become congruent with the etch figures, as *a*, on the adjacent prism face.

In this type an axis of digonal symmetry ends in the edge; the etch figure *a*, if revolved around this axis 180° , will be congruent with *a'*. They are oppositely oriented on adjacent faces.

In type 25, the ditetragonal polar, where there is a vertical plane of symmetry crossing the prism face and the vertical axis is a ditetragonal axis and no equatorial plane or digonal axes, the etch figure on each face is symmetrical to a vertical plane only; and revolved around the vertical axis c 90° will become congruent with those on the adjacent face, as a' . a will also be a reflection of a' , across the plane of symmetry containing the edge between them.

In type 24, the tetragonal equatorial, where the vertical axis is a tetragonal axis of symmetry and has an equatorial plane, the etch figure will be symmetrical to the equatorial plane. By a revolution of 90° around the vertical axis it will become congruent with a' , on the adjacent prism face, but a is not a reflection of a' , as here there is no plane of symmetry between them.

In type 23, the tetragonal holoaxial, where there are no planes of symmetry and the vertical axis is a tetragonal axis and there are four digonal axes in the equatorial plane, the etch figure must have a center of symmetry; and if revolved 90° around the vertical axis or 180° around the crystallographical axis, it must become congruent with a' , the etch figures on the adjacent crystal faces. The figure a' is not a reflection of a , as there is no plane of symmetry between them.

In type 22, the tetragonal alternating, where there are no planes of symmetry and the vertical axis is a tetragonal alternating axis, the etch figure a will be asymmetric; and if revolved around the vertical axis c 90° , then reflected over the equatorial plane, will become congruent with a' , on the adjacent prism face.

In type 21, the tetragonal polar, where the vertical axis is a tetragonal axis, the etch figure a will be asymmetric and will become congruent with a' by a rotation of 90° around the vertical axis c .

From the several diagrams it will be seen that each of the seven possible prisms of the first order, though alike in outward form, possesses the symmetry of the type, which is revealed by the shape and relation of the etch figures on the form.

Crystalline elements. — In the isometric system, as the axes are all interchangeable, the crystalline characters are fixed and are the same for all substances crystallizing in the system. In the tetragonal system the axial ratio $\frac{c}{a}$ varies with the substance; its value is constant, however, for each chemically pure substance. The axial ratio is calculated from the angles of the fundamental forms, or those forms which intercept the axes at unity.

Example. — The axial ratio of zircon is calculated directly from the pyramid of the second order (101), Fig. 147; the angle cao is found by measurement to be $32^\circ 38' 4''$, in the triangle coa right-angled at o . $\tan cao = \frac{co}{oa}$, but $oc = c$ and $oa = a$; $\tan cao = \frac{c}{a} = .6404$. In the tetragonal system the lateral axis a is assumed as the unit of measurement, therefore $c = .6404$ is the axial ratio of zircon.

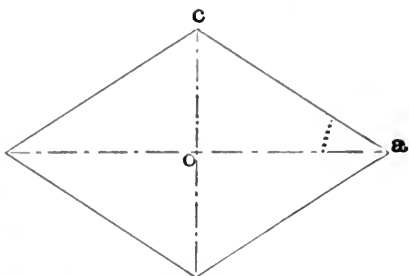

FIG. 147. — Zircon, (101).

When the pyramid of the first order is the fundamental form in which the angle is measured (111), Fig. 148 at a' , at right

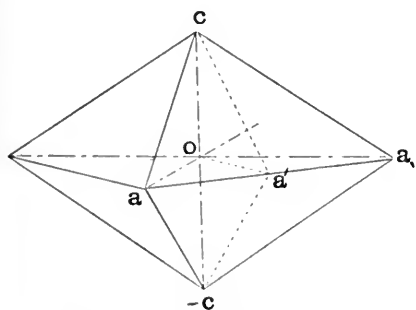

FIG. 148. — Cassiterite, (111).

angles to aa_1 ; $\tan ca'o = \frac{oc}{oa'}$;

$oc = oa' (\tan ca'o)$, also $oa' = a'a_1 = \frac{1}{2}aa_1 = \frac{1}{2}\sqrt{2}$. $\therefore c = \frac{1}{2}\sqrt{2} (\tan ca'o)$.

In rutile $ca'o$ is $42^\circ 10'$.

$\text{Log } \tan 42^\circ 10' = 9.959616 + 10$

$\text{Log } \frac{1}{2}\sqrt{2} = \bar{1}.849485$

$\text{Log } c = 9.809101 - 10$

$c = .644^+$, the axial

ratio of rutile.

When the axial ratio is known, it is an easy problem to calculate the value of the variables m and n in any set of parameters; thus in rutile there is a pyramid of the second order in which the angle corresponding to cao , Fig. 147, is $78^\circ 15'$; $\tan 78^\circ 15' = \frac{c}{a} = \frac{c}{1} = 4.8$ or nearly 5; its parameters would be $(a : \infty a : 5c)$, and indices (501).

CHAPTER V

HEXAGONAL SYSTEM

THE hexagonal system includes all those crystals which may be referred to four axes, three of which, the lateral axes, lie in one plane, the equatorial plane. They are equal and interchangeable and inclined 60° to each other. They are all designated by the letter a . The order of + and - extremities are as shown in Fig. 149. The fourth or c axis is the vertical axis and is at right angles to the a axes and not interchangeable with them. It may be either longer or shorter.

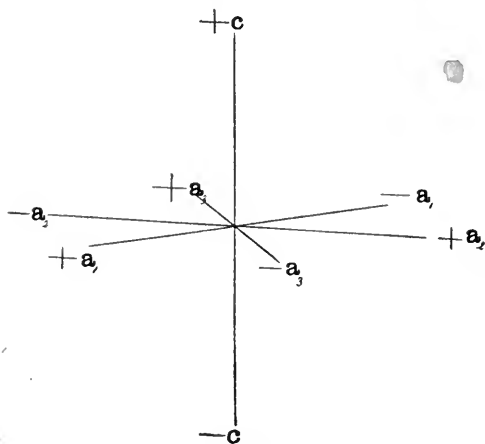

FIG. 149.

In the hexagonal system the parameters have four terms, and are written in the following order, $na_1 : pa_2 : \bar{a}_3 : mc$. As all three lateral axes are in the equatorial plane and all faces, except the base, intersect this plane in straight lines, two lateral axes and the c axis will fix the inclination of any face, for the straight line dd' , Fig. 150, is fixed by the intercepts on the axes a_1 and a_2 . The value of the intercept a_2 , or the coefficient p in the general set of parameters, when one intercept is

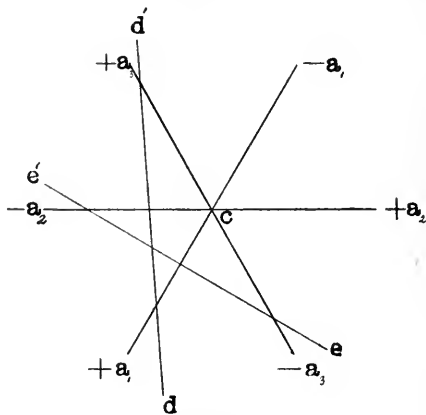

FIG. 150.

unity p , is a function of the other intercept n . The value of p expressed in terms of n is $\frac{n}{n-1}$; $\frac{n}{n-1}$ will increase as n decreases, until n is unity, when $\frac{n}{n-1}$ becomes infinity, or if the value of n increases, $\frac{n}{n-1}$ decreases, and when $n = 2$, $\frac{n}{n-1} = 2$; the value of n may vary between 1 as its minimum limit and 2 as its maximum limit; m , the coefficient of c , is independent of n and may vary between 0 and ∞ . There will also be four terms in the indices of any plane, thus $h\bar{k}i\bar{l}$, where i represents the smallest intercept. Of the three indices $h\bar{k}i$, two will always be of the same sign and the third of the opposite sign, and the algebraic sum of these three indices is always zero. Their relative values are $i > h > k$ and $h + k = i$. In writing the indices l always stands last and represents the c axis not interchangeable with the lateral axes. Twelve of the thirty-two types are included in the hexagonal system, all of which possess at least one axis of trigonal symmetry.

CLASS, HEXAGONAL HOLOHEDRAL (HOLOSYMMETRIC)

TYPE 20, DIHEXAGONAL EQUATORIAL

Symmetry. — Crystals of this type possess one **dihexagonal axis**, the c axis, **6** didigonal axes, all lying in the equatorial plane and inclined at an angle of 30° to each other, three of which are the

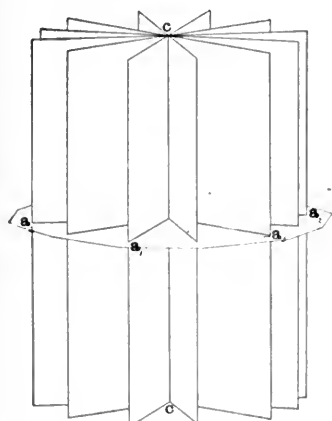

FIG. 151.

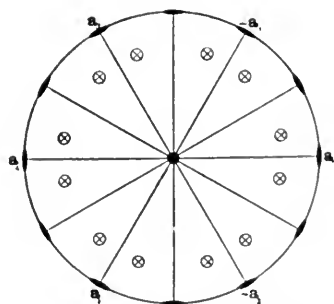

FIG. 152. — Type 20, Dihexagonal Equatorial.

lateral crystallographical axes. The remaining three bisect the angles between the lateral axes. There are seven planes of symmetry, one of which, the equatorial plane, contains the didigonal axes and is at right angles to the *c* axis. The other six planes all intersect in the *c* axis and each contains one of the didigonal axes. They are therefore inclined to each other at an angle of 30° , Fig. 151. These seven planes of symmetry divide space into 24 equal portions or solid angles. The largest number of faces on any hexagonal form will be 24, or one face in each solid angle. There is also a center of symmetry and the forms of this type will all be bounded by pairs of parallel faces, Fig. 152.

Forms

I. Dihexagonal pyramid; $na : \frac{n}{n-1}a : a : mc$; ($hk\bar{i}l$).

This form is represented by one face in each of the 24 solid angles and is bounded by 24 scalene triangular faces, Fig. 153; each face

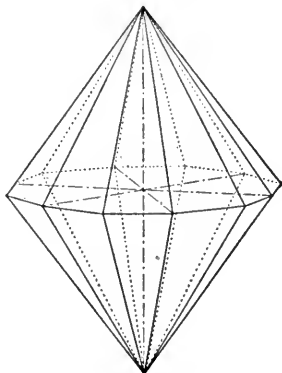

FIG. 153.—Dihexagonal Pyramid,

$$na : \frac{n}{n-1}a : a : mc ; (hk\bar{i}l).$$

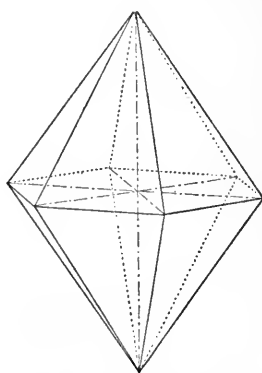

FIG. 154.—Hexagonal Pyramid of the First Order,
 $a : \infty a : \bar{a} : c$, ($h\bar{o}hl$).

cuts the lateral axes at a different distance. The equatorial edges are all equal, and the alternate polar edges are equal.

II. Hexagonal pyramid of the first order; $a : \infty a : a : mc$; ($h\bar{o}hl$).

If the poles in Fig. 152 be moved into the intermediate planes of symmetry so as to lie on that side of the triangle between the intermediate and the hexagonal axes, then the number of faces will be reduced to 12, and a new form will result, the hexagonal pyramid of the first order, Fig. 154, bounded by 12 isosceles triangles.

Each face cuts two of the lateral axes at an equal distance and is parallel to the third. The axes therefore end in the tetrahedral angles, making it a pyramid of the first order.

III. Hexagonal pyramid of the second order; $2a : 2a : a : mc$; $(hh\bar{2}hl)$.

If the poles in Fig. 152 are moved into the diametral planes, then the faces of the most general form will be reduced to 12 isosceles triangles, Fig. 155, each face cutting two of the lateral axes at an equal distance and the third at one half that distance. The a axes will bisect the equatorial edges, making the form a pyramid of the second order.

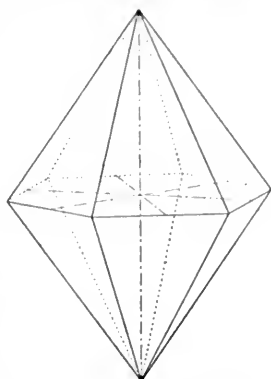

FIG. 155. — Pyramid of the Second Order, $2a : 2a : \bar{a} : c$, $(hh\bar{2}hl)$.

IV. Dihexagonal prism; $na : \frac{n}{n-1}a : a : \infty c$; $(hk\bar{1}0)$.

The poles are now moved to the equatorial plane between the axes of symmetry, when the faces will be reduced to 12, all of which are

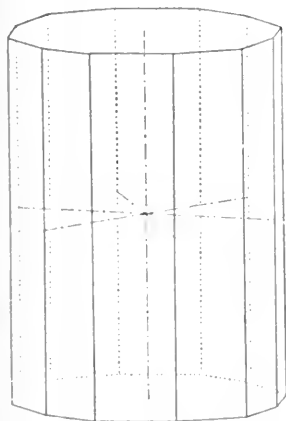

FIG. 156. — Dihexagonal Prism,
 $na : \frac{n}{n-1}a : a : mc$, $(hk\bar{1}0)$.

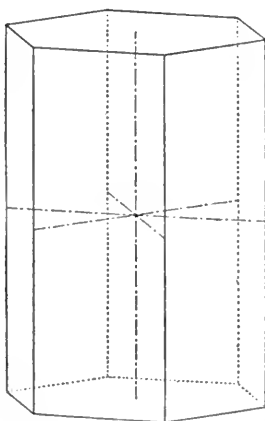

FIG. 157. — Hexagonal Prism of the First Order, $a : \infty a : a : \infty c$, $(h0h0)$.

parallel to the c axis, yielding an open form, Fig. 156, the **dihexagonal prism**, alternate edges of which are similar.

V. Hexagonal prism of the first order; $a : \infty a : a : \infty c$; ($hoh\bar{1}$).

Three possible positions of the poles now remain, the three angles of the triangle, each position yielding one of the three fixed forms. The four forms already developed represent the variable forms, there being a series of each. If the poles coincide with the intermediate axes, Fig. 152, four faces of the most general form will fall in one plane, producing an open form, the hexagonal prism of the first order, bounded by 6 faces, all of which are parallel to the c axis, Fig. 157. Each face cuts two lateral axes at the same distance and is parallel to the third.

VI. Hexagonal prism of the second order; $2a : 2a : a : \infty c$; ($hh\bar{2}ho$).

In this form the poles will coincide with the lateral crystallographical axes. It is bounded by 6 faces, each of which cuts two lateral axes at the same distance, and the third at one half that distance. The axes will therefore terminate in the center of the faces, Fig. 158.

VII. Basal pinacoid; $\infty a : \infty a : \infty a : mc$, (0001).

If the poles are moved to the c axis the number of faces will be reduced to a single pair of faces parallel to the equatorial plane. They terminate the prisms as shown in Fig. 158.

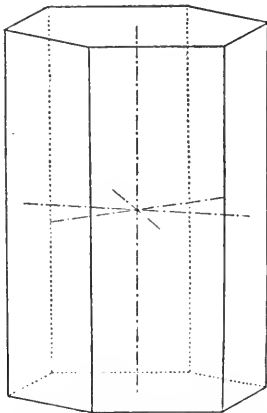

FIG. 158. — Hexagonal Prism of the Second Order ($hh\bar{2}ho$).

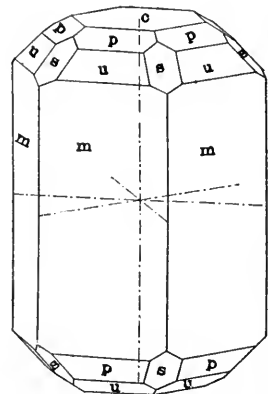

FIG. 159. — Beryl, a Combination of m ($10\bar{1}0$), u ($20\bar{2}1$), s ($11\bar{2}1$), p ($10\bar{1}1$), c (0001).

The forms possible to combine on crystals of the dihexagonal equatorial type are :

Dihexagonal pyramid, ($hkil$).

Hexagonal pyramid of the first order, ($hohl$).

Hexagonal pyramid of the second order, ($hh\bar{z}hl$).

Dihexagonal prism, ($hkio$).

Hexagonal prism of the first order, ($hoho$).

Hexagonal prism of the second order, ($hh\bar{z}ho$).

Hexagonal base, (0001).

Examples. — Few minerals crystallize in this type; as a rule the holosymmetric class in other systems is the most important class in the system.

Beryl, $Be_3Al_2(SiO_3)_6$, Fig. 159, represents a combination of five forms on a crystal of beryl.

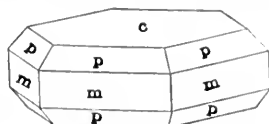

FIG. 160. — Hanksite, $c(0001)$, $m(10\bar{1}0)$, $p(10\bar{1}1)$.

Hanksite, $9 Na_2SO_4 \cdot 2 Na_2CO_3 \cdot KCl$,

Fig. 160, represents a combination of three forms on a crystal of hanksite.

CLASS, RHOMBOHEDRAL HEMIHEDRONS

TYPE 19, DIHEXAGONAL ALTERNATING

Symmetry. — Crystals of this type possess one dihexagonal alternating axis, the c axis; three ~~trigonal~~ trigonal axes, the lateral crystallographical axes, three planes of symmetry, intersecting in the c axis and each containing one of the intermediate lateral axes, and

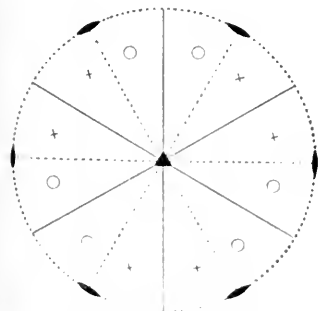

FIG. 161. — Type 19, Dihexagonal Alternating.

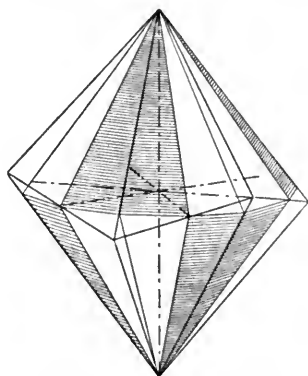

FIG. 162. — The Positive Scalenohedron, $k(hh\bar{1}l)$.

also a center of symmetry, Fig. 161. It is to be noted here that the equatorial plane of type 20 is lost and the equatorial edge in the two new forms of the type is represented by a zigzag edge. Forms of this type may be derived from the holohedral forms of type 20

by the extension of all planes in alternate dodecants above and below the equatorial plane, as the shaded faces of Fig. 162.

Forms

I. Scalenohedron $\pm \frac{na : \frac{n}{n-1} a : a : mc}{2}$; $\kappa(h\bar{k}i\bar{l}), \kappa(kh\bar{i}l)$.

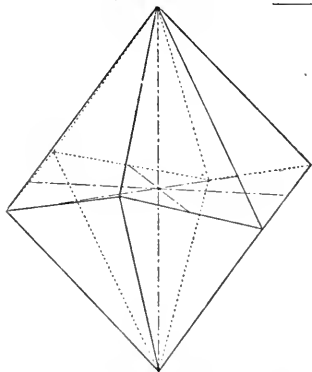

FIG. 163.—The Minus Scalenohedron, $\kappa(h\bar{k}i\bar{l})$.

The faces represented by the poles in Fig. 161 when extended will yield the minus scalenohedron, Fig. 163, a form bounded by 12 similar scalene triangles. Six faces are grouped around the extremities of the c axis. Alternate edges are equal both as to length and angle. The equatorial edge of the dihexagonal pyramid is replaced by 6 equal zigzag edges, each of which is bisected by the extremity of a lateral axis.

II. Rhombohedron of the first order, $\pm \frac{a : \infty a : a : mc}{2}$; $\kappa(hohl), \kappa(oh\bar{h}l)$.

When the poles of Fig. 161 are moved into the planes of symmetry, a form, the rhombohedron of the first order, Fig. 164, bounded by 6 similar rhombic faces, is the result. The form is plus if the pole is moved into the plane of symmetry lying between the a_1 and \bar{a}_3 axes in front, and the minus form is produced when they are moved into the plane between a_2 and \bar{a}_3 .

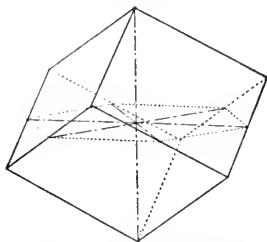

FIG. 164.—The Minus Rhombohedron of the First Order, $\kappa(oh\bar{h}l)$.

There are three faces grouped around each extremity of the c axis, and three equal edges. The six zigzag edges which are bisected by the extremities of the lateral axes are

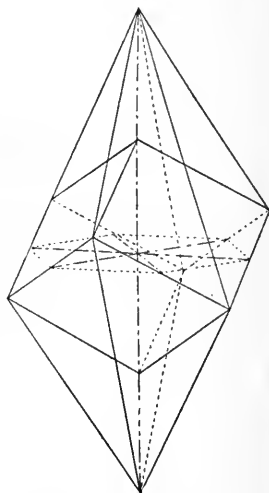

FIG. 164 a.—The Rhombohedron of the Middle Edge and Scalenohedron.

equal in length to the polar edges but differ in angle. These edges correspond in position to the zigzag edges of the scalenohedron. For each scalenohedron there is a corresponding rhombohedron, Fig. 164 *a*, termed the rhombohedron of the middle edges. When in combination, it bevels symmetrically the edges of the scalenohedron, Fig. 165.

Other forms. — All other possible positions of the poles yield forms similar in shape to the holohedral forms of type 20, but when found in combination with a rhombohedron or a scalenohedron they must be considered as of hemihedral symmetry.

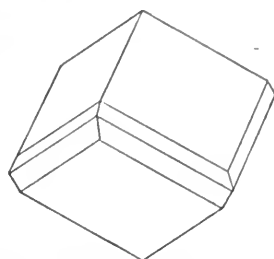

Fig. 165.—Combination of the Scalenohedron and the Rhombohedron of the Middle Edge.

The possible forms to combine in this type are :

Plus and minus scalenohedron, $\kappa(hk\bar{i}l)$, $\kappa(kh\bar{i}l)$.

Plus and minus rhombohedron of the first order, $\kappa(ho\bar{h}l)$, $\kappa(o\bar{h}hl)$.

Hexagonal pyramid of the second order, (hh_2hl) .

Dihexagonal prism, $(hk\bar{i}o)$.

Hexagonal prism of the first order, $(ho\bar{h}o)$.

Hexagonal prism of the second order, (hh_2ho) .

Hexagonal base, (0001) .

Examples. — The rhombohedral class is the most important class of the hexagonal system, as a large number of common and commercially important minerals belong here.

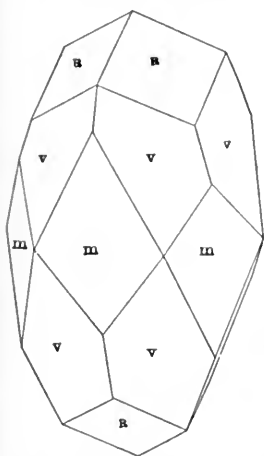

Fig. 166.—Calcite, Combination of $R(10\bar{1}1)$, $m(10\bar{1}0)$, $v(21\bar{3}1)$.

Calcite, $CaCO_3$, Fig. 166, is a combination of $R(10\bar{1}1)$, $m(10\bar{1}0)$, $v(21\bar{3}1)$.

Hematite, Fe_2O_3 , Fig. 167, is a combination of a base and the plus and minus rhombohedron.

Corundum, Al_2O_3 ; Siderite, $FeCO_3$; Arsenic; Antimony; Brucite, $MgO \cdot H_2O$, — also crystallize in this type.

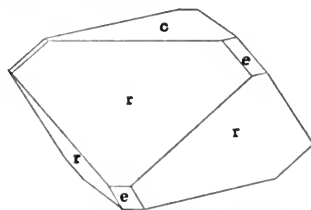

Fig. 167.—Hematite, $c(0001)$, $r(10\bar{1}1)$, $e(\bar{1}101)$.

CLASS, DIHEXAGONAL HEMIMORPHIC

TYPE 18, DIHEXAGONAL POLAR

Symmetry. — By a polar development of the holohedral forms of type 20, all the symmetry lying in the equatorial plane is lost, leaving the dihexagonal axis and the six vertical planes intersecting in the *c* axis as the symmetry of this type, Fig. 168.

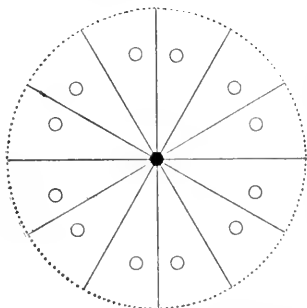

FIG. 168. — Type 18, Dihexagonal Polar.

Forms. — The new forms would be, upper and lower dihexagonal hemipyramids, Fig. 169. Also upper and lower hexagonal hemipyramids of the first and second orders, Fig. 170.

Possible forms to be found in combination on crystals of this type would be:

Upper and lower dihexagonal hemipyramid,

$$u/1 \left(\frac{na : \frac{n}{n-1} : a : mc}{2} \right); (\overline{hkil}), (hk\overline{il}).$$

Upper and lower hemipyramid of the second order,

$$u/1 \left(\frac{2a : 2a : a : mc}{2} \right); (\overline{hh2hl}), (hh2\overline{hl}).$$

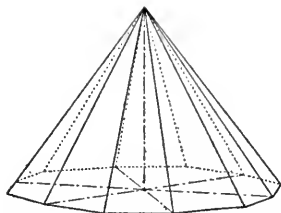

FIG. 169. — The Upper Dihexagonal Hemipyramid, (\overline{hkil}) .

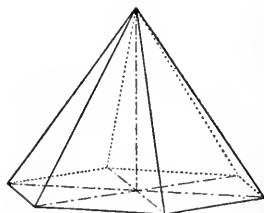

FIG. 170. — The Upper Hexagonal Hemipyramid of the First Order, (\overline{hoh}) .

Upper and lower hemipyramid of the first order,

$$u/1 \left(\frac{a : \infty a : a : mc}{2} \right); (\overline{hohl}), (hoh\overline{l}).$$

Dihexagonal prism, $na : \frac{n}{n-1} : a : \infty c$; (\overline{hkio}) .

Hexagonal prism of the first order, $a : \infty a : a : \infty c$; $(\overline{io\overline{io}})$

Hexagonal prism of the second order, $2a : 2a : a : \infty c$; $(\overline{i1\overline{2o}})$.

Upper and lower base, $\infty a : \infty a : \infty a : c$; (0001) , $(000\bar{1})$.

Examples. — Greenockite, CdS, Fig. 171, is a combination of five forms.

Iodide of Silver, AgI, Fig. 172, is a top-shaped combination of an upper and a lower hemipyramid with the first order prism.

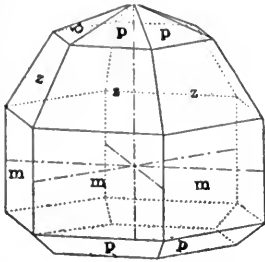

FIG. 171. — Greenockite, a Combination of $p(10\bar{1}1)$, $p(10\bar{1}\bar{1})$, $m(10\bar{1}0)$, $z(20\bar{2}1)$, $c(000\bar{1})$.

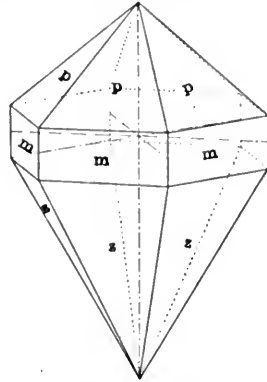

FIG. 172. — $m(10\bar{1}0)$, $p(10\bar{1}1)$, $z(20\bar{2}1)$.

Wurtzite, ZnS, and Zincite, ZnO, are other minerals which crystallize in this type.

CLASS, HEMIHEDRAL PYRAMIDAL (PARALLEL-FACED HEMIHEDRONS)

TYPE 17, HEXAGONAL EQUATORIAL

Symmetry. — Crystals of this type are symmetrical in regard to one axis of hexagonal symmetry, the c axis, one plane of sym-

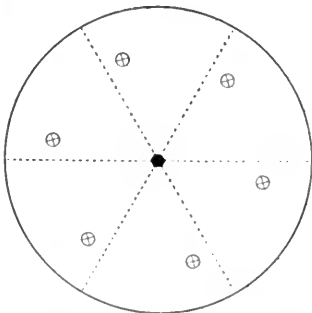

FIG. 173. — Type 17, Hexagonal Equatorial.

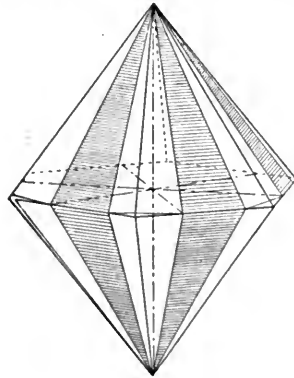

FIG. 174.

metry, the equatorial plane, and a center, Fig. 173. The forms are parallel-faced hemihedrons, and may be considered as derived from the holohedrons of type 20 by extending alternate pairs of faces which intersect in the equatorial edge, as the shaded faces in Fig. 174, which will produce a minus hemihedron.

Forms

I. Hexagonal pyramid of the third order,

$$\text{na} : \frac{\text{n}}{\text{n}-1} \text{a} : \text{a} : \text{mc} \\ \pm \frac{\text{na} : \frac{\text{n}}{\text{n}-1} \text{a} : \text{a} : \text{mc}}{2} ; \pi(\text{hk}\bar{\text{i}}\bar{\text{l}}), \pi(\text{kh}\bar{\text{i}}\bar{\text{l}}).$$

The faces represented by the poles of Fig. 173 bound a pyramid, which in shape does not differ from the hexagonal pyramid of the first or second order except here the lateral axes do not terminate either in the center of the faces or bisect the edges, but on the line

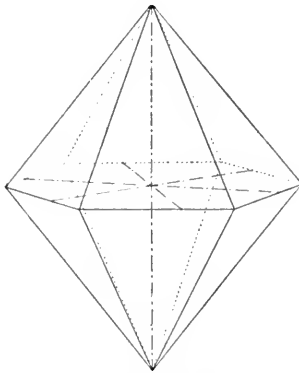

FIG. 175. — The Hexagonal Pyramid of the Third Order.

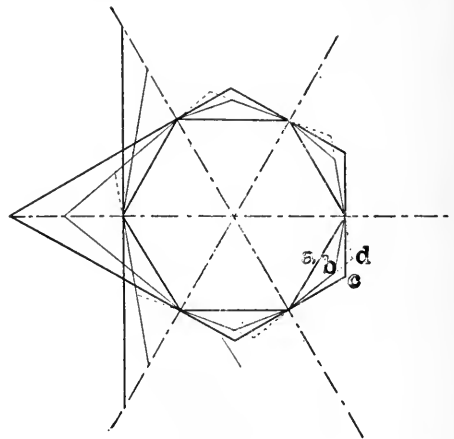

FIG. 176.

connecting these two points, Fig. 175, also Fig. 176, which is a plan of the first, second, and third order pyramids and prisms drawn on the equatorial plane.

II. Hexagonal prism of the third order,

$$\pm \left[\frac{\text{na} : \frac{\text{n}}{\text{n}-1} \text{a} : \text{a} : \infty \text{c}}{2} \right] ; \pi(\text{hk}\bar{\text{i}}\bar{\text{o}}), \pi(\text{kh}\bar{\text{i}}\bar{\text{o}}).$$

If the poles in Fig. 173 are moved so as to lie upon the equator, between the *a* axes and the intermediate axes, then two faces of the

pyramid of the third order will fall in one plane, producing a new open form, the prism of the third order, Fig. 177, in which the a axes neither terminate in the edges or in the center of the faces, but on the line drawn between these two points.

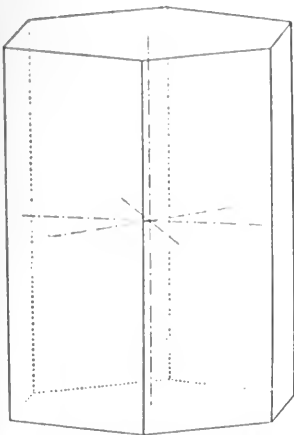

FIG. 177. — Hexagonal Prism of the Third Order.

III. Other forms of this type are like the hexagonal holohedral in shape. The possible forms to be found in combination will be :

Plus and minus hexagonal pyramid of the third order, $\pi(\overline{hkil})$, $\pi(kh\overline{il})$.

Hexagonal pyramid of the first order, $\pi(\overline{ho\overline{hl}})$.

Hexagonal pyramid of the second order, $\pi(\overline{hh\overline{2hl}})$.

Plus and minus hexagonal prism of the third order, $\pi(\overline{hk\overline{io}})$, $\pi(kh\overline{io})$.

Hexagonal prism of the first order, $\pi(\overline{ho\overline{ho}})$.

Hexagonal prism of the second order, $\pi(\overline{hh\overline{2ho}})$.

Hexagonal base, $\pi(0001)$.

Examples. — Apatite, $\text{Ca}_5(\text{FCl})(\text{PO}_4)_3$, Fig. 178, shows a combination of the three pyramids, a prism, and the base.

Pyromorphite, $\text{Pb}_5\text{Cl}(\text{PO}_4)_3$; Mimeticite, $\text{Pb}_5\text{Cl}(\text{AsO}_4)_3$, and Vanadinite, $\text{Pb}_5\text{Cl}(\text{VO}_4)_3$, — also crystallize in this group.

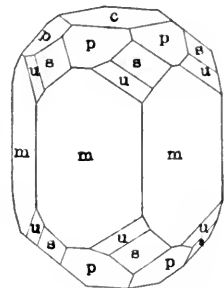

FIG. 178. — Apatite, a Combination of p (1011), u (1231), s ($11\overline{2}1$), m ($10\overline{1}0$), c (0001).

CLASS, TRAPEZOIDAL (PLAGIOHEDRAL) HEMIHEDRONS

TYPE 16, HEXAGONAL HOLOAXIAL

Symmetry. — Crystals of this type possess all the axes of the di-hexagonal equatorial type, but no planes, or center of symmetry. They have therefore one axis of hexagonal symmetry, the c axis, and six digonal axes corresponding to the lateral and intermediate axes, lying in the position of the equatorial plane, Fig. 179. The forms are plagiohedral and may be derived from the holohedral forms by extending alternate faces around the poles, Fig. 180.

Forms. — Hexagonal trapezohedrons,

$$na : \frac{n}{n-1} a : a : mc$$

$$r/l \frac{n}{2} ; \tau(\overline{hkil}), \tau(kh\bar{i}l).$$

The faces represented by the poles in Fig. 179 yield a form bounded by 12 similar trapezoidal faces, Fig. 181, the right trapezohedron. If the shaded faces are extended, the left trapezohedron, Fig. 180, is formed. Six faces are grouped around each extremity of the *c* axis, making equal angles and equal polar edges. The median edges are alternately long and short; the crystallographical axes terminate in the middle of the long edges. In looking at a south polar edge, with the crystal form vertical, if the long median edge is to the right, it is a right-handed form; if to the left, it is a left-handed form.

Other forms. — All other possible positions of the poles, as the sides and angles of the triangles in Fig. 179, will yield holohedral

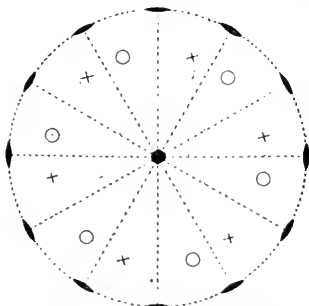

FIG. 179. — Type 16, Hexagonal Holoaxial.

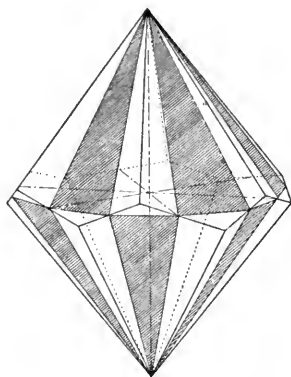

FIG. 180. — The Left Hexagonal Trapezohedron.

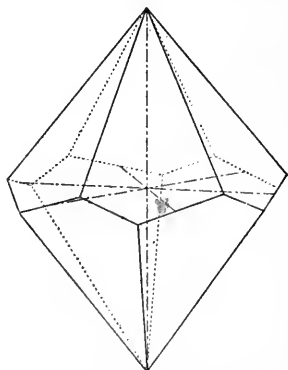

FIG. 181. — The Right Hexagonal Trapezohedron, $\tau(\overline{hkil})$.

shapes. The possible forms therefore to be found in combination on crystals of this type will be:

Right and left hexagonal trapezohedrons, $\tau(\overline{hkil})$, $\tau(kh\bar{i}l)$.

Hexagonal pyramid first order, $\tau(\overline{hohl})$.

Hexagonal pyramid second order, $\tau(\overline{hhzhl})$.

Dihexagonal prism, $\tau(\overline{hkio})$.

Hexagonal prism first order, $\tau(\overline{ho\bar{h}l})$.

Hexagonal prism second order, $\tau(\overline{hhzho})$.

Hexagonal base, $\tau(0001)$.

Examples. — There has been as yet no mineral assigned to this type; in fact, the trapezohedron has never been observed on any crystal. There are, however, several salts included here, as barium stibiotartrate, $Ba(C_4H_4O_6)_2SbO_2$, KNO_3 , which from the symmetry of its etching figures must crystallize with an hexagonal holoaxial symmetry.

CLASS, RHOMBOHEDRAL TETARTOHEDRONS

TYPE 15, HEXAGONAL ALTERNATING

Symmetry. — Crystals of this type possess an alternating hexagonal axis, the *c* axis, and a center of symmetry, but no planes of symmetry, Fig. 182. The forms of this type are tetartohedrons, derived by superimposing type 17 upon type 19, and extending the faces not selected by these two types to produce a new form. If the dihexagonal pyramid is rolled out, the faces being numbered; the equatorial edge represented by a horizontal line, and the terminations of the *a* axes marked by a vertical line, as here represented:

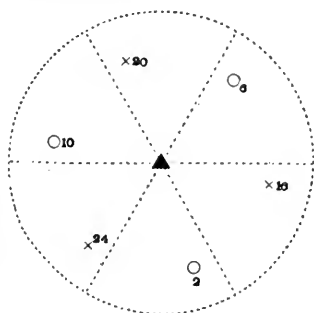

FIG. 182. — Type 15, Hexagonal Alternating.

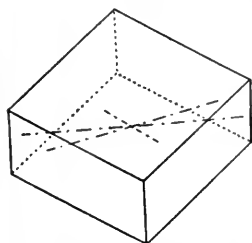
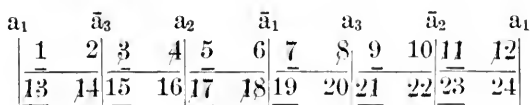

FIG. 183. — The Plus Rhombohedron of the Third Order, (\overline{hkil}) .

H

If a line be drawn through those faces which are extended by the method of selection used to produce forms of type 19, and a line drawn under those selected in type 17, then it will be seen that there are three faces above and three faces below the equatorial plane not marked.

The faces 2, 6, and 10 do not lie symmetrically above the three faces, 16, 20, and 24, neither do these faces lie symmet-

rically between the lateral axes. When these six faces are extended, the plus right tetartohedron will be formed, but it is easily seen that the superposition of the two hemihedrons may be so arranged that in place of 2 being selected, 1 and the corresponding faces could have been taken, forming the plus left rhombohedron or 13 could have been selected, the minus right; or 14, the minus left, — thus yielding four possible forms, the plus and minus right, congruent forms, and the plus and minus left, also congruent forms. The rights are not congruent with the lefts.

Forms

I. Rhombohedrons of the third order,

$$\pm r/1 \left[\frac{na : \frac{n}{n-1} a : a : mc}{4} \right]; +r(\overline{hkil}), +l(\overline{ikh\bar{l}}), -r(\overline{khil}), -l(\overline{ih\bar{k}l}).$$

When the faces represented by the poles of Fig. 182 are extended, they will inclose space and yield a rhombohedron of the third order,

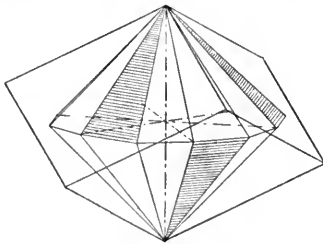

FIG. 184.—The Plus Left Rhombohedron of the Third Order, $(\overline{ikh\bar{l}})$.

Fig. 183, which does not differ in shape from the rhombohedron of the first order; the lateral axes, however, do not end in the central point of the edges, but terminate asymmetrically in the faces on the line drawn between the central points of the zigzag edges. As is shown above, there are four rhombohedrons of the third order. Fig.

183 is a plus right and Fig. 184 is a plus left rhombohedron of the third order.

II. Rhombohedron of the second order $\pm \left(\frac{2a : 2a : a : mc}{2} \right); (\overline{hh\bar{z}hl}), (\overline{zh\bar{h}hl})$.

If the poles in Fig. 182 are moved into the diametral planes, it will be the same as revolving the rhombohedron of the third order until the lateral axes terminate in the median point of the line drawn between the centers of the zigzag edges. In this position the right form will coincide with the left, and only plus and minus forms

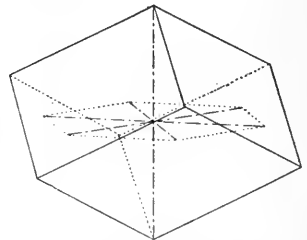

FIG. 185.—Rhombohedron of the Second Order, $(\overline{hh\bar{z}hl})$.

will remain. These are the rhombohedrons of the second order, Fig. 185, derived from the hexagonal pyramid of the second order.

III. Rhombohedrons of the first order.

If the poles are moved into the plane containing the intermediate axes, the resulting form is the rhombohedron of the first order.

The three rhombohedrons differ only in the position of the lateral axes: in the first order they end in the central point of the zigzag edges; in the second order they end in the median point of the line connecting the central points of the zigzag edges; in the third order they end asymmetrically on this same line between the above two points.

Other forms. — When the poles are moved to the equatorial plane the first, second, and third order prisms are formed.

The possible forms to combine on crystals of this type will be :

Plus and minus right and plus and minus left rhombohedrons of the third order, (\overline{khil}), (\overline{hkil}), (\overline{ihkl}), (\overline{ikhl}).

Plus and minus rhombohedrons of the second order, ($\overline{hhzh1}$), ($\overline{zhhh1}$).

Plus and minus rhombohedrons of the first order, (\overline{hkil}), (\overline{khil}).

Plus and minus prisms of the third order, (\overline{hoho}), (\overline{ohho}).

Hexagonal prism of the second order, (\overline{hhzho}).

Hexagonal prism of the first order, (\overline{hoho}).

Hexagonal base, (0001).

Examples. — Dolomite, $MgCa(CO_3)_2$; Phenacite, Be_2SiO_4 ; Willemite, Zn_2SiO_4 ; and Dioptase, H_2CuSiO_4 , — crystallize in this type, Fig. 186.

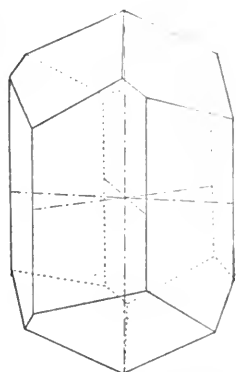

FIG. 186. — Phenacite, a Combination of the Negative Right Rhombohedron of the Third Order and the Prism of the First Order.

CLASS, PYRAMIDAL HEMIMORPHIC

TYPE 14, HEXAGONAL POLAR

Symmetry. — Crystals of this type possess an axis of hexagonal symmetry, the c axis, and no plane or center of symmetry. It is a polar development of the hexagonal equatorial type. Fig. 187 shows the symmetry.

Forms

I. Hexagonal hemipyramid of the third order,

$$\pm u/l \left[\frac{na : \frac{n}{n-1} a : a : mc}{2} \right]; (\overline{hkil}), (k\overline{hil}), (h\overline{ki}l), (k\overline{h}il).$$

The upper or lower half of the pyramid of the third order may occur independently, Fig. 188.

Other forms are the same as in type 18. The possible forms to combine in this type will be—

Plus and minus upper and plus and minus lower hemipyramids of the third order, (\overline{hkil}) , $(k\overline{hil})$, $(h\overline{ki}l)$, $(k\overline{h}il)$.

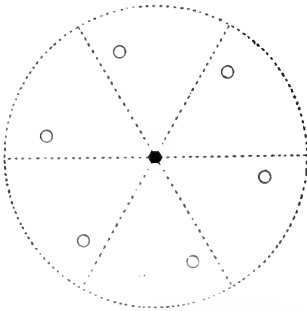

FIG. 187. — Type 14, Hexagonal Polar.

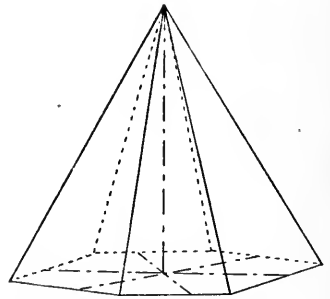

FIG. 188. — The Upper Hexagonal Hemipyramid of the Third Order.

Upper and lower hemipyramid of the first order, (\overline{hkil}) , $(h\overline{ki}l)$.

Upper and lower hemipyramid of the second order, (\overline{hhzhl}) , $(hhz\overline{hl})$.

Plus and minus hexagonal prism of the third order, (\overline{hkio}) , $(k\overline{h}io)$.

Hexagonal prism of the first order, $(10\overline{1}0)$.

Hexagonal prism of the second order, $(11\overline{2}0)$.

Hexagonal base, upper and lower, (0001) , $(000\overline{1})$.

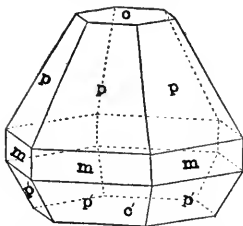

FIG. 189. — Combination of $p(10\overline{1}1)$, $p(10\overline{1}1)$, $m(10\overline{1}0)$, $c(0001)$, $c'(000\overline{1})$.

Examples. — Crystals in this type are rare and the hemipyramid of the third order, which is the only form characteristic of the type, does not occur on any mineral, but from the symmetry of the etching figures, nephelite, $K_2Na_6Al_6Si_6O_{34}$, is placed here; as are also the double sulphate of the alkali metals, potassium and

lithium, KLiSO_4 ; lithium, ammonium, LiNH_4SO_4 ; and lithium and rubidium, LiRbSO_4 . Fig. 189 shows the appearance of these combinations.

CLASS, TRIGONAL HEMIHEDRONS

TYPE 13, DITRIGONAL EQUATORIAL

Symmetry. — Crystals of this type possess one ditrigonal axis, the *c* axis, three didigonal axes, the intermediate lateral axes, and four planes, three of which intersect in the *c* axis and each contains one of the didigonal axes. The fourth is at right angles to these and contains the *a* axes. Fig. 190 illustrates this sym-

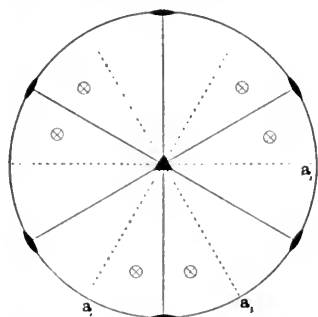

FIG. 190. — Type 13, Ditrigonal Equatorial.

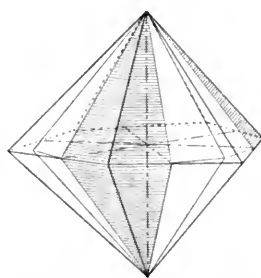

FIG. 191. — The Plus Ditrigonal Pyramid ($hk\bar{i}l$).

metry. The forms may be considered as hemihedrons, derived from type 20 by extending all the faces in alternate dodecants around the north pole and dodecants below, which intersect with these in the equator, as the shaded faces in Fig. 191.

Forms

I. Ditrigonal pyramid, $\pm \left[\frac{na : \frac{n}{n-1} a : a : mc}{2} \right]$; $(hk\bar{i}l)$, $(i\bar{h}kl)$.

The faces represented by the poles in Fig. 190 or shown in Fig. 191, in their relation to the hexagonal pyramid, when extended, form the plus ditrigonal pyramid. A form bounded by 12 scalene triangles, meeting in six equal equatorial edges. There are 12 polar edges, six around each extremity of the *c* axis, alternate edges are similar both as to length and angle. Fig. 192 represents the - ditrigonal pyramid.

II. Trigonal pyramid of the first order, $\pm \left(\frac{a : \infty a : a : mc}{2} \right)$; $(h\bar{o}hl)$, $(o\bar{h}hl)$.

When the poles of Fig. 190 are moved into the vertical planes of symmetry, two adjacent faces of the ditrigonal pyramid will fall in one plane, producing a form, the trigonal pyramid of the first order, bounded by six isosceles triangles, Fig. 193; here the rela-

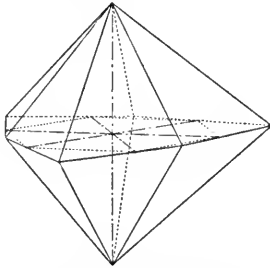

FIG. 192. — The Negative Ditrigonal Pyramid.

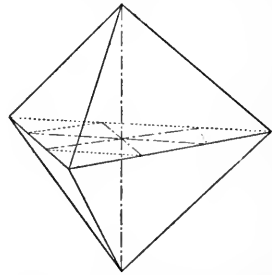

FIG. 193. — Trigonal Pyramid of the First Order, $(01\bar{1}1)$.

tion of the faces to the hexagonal pyramid of the first order is also shown. The lateral crystallographical axes terminate, two in each equatorial edge, dividing it into three equal parts.

III. Ditrigonal prism, $\pm \left(\frac{na : \frac{n}{n-1} a : a : \infty c}{2} \right)$; $(h\bar{k}io)$, $(k\bar{h}io)$.

If the poles are moved to the equator between the a axes and the intermediate axes, the ditrigonal prism results, Fig. 194, a form

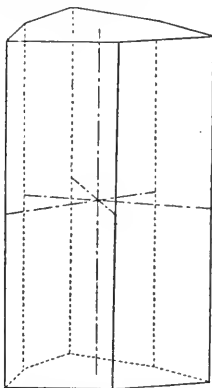

FIG. 194. — Ditrigonal Prism, $(h\bar{k}il)$.

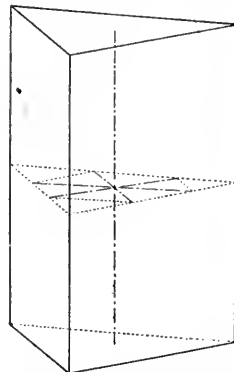

FIG. 195. — The Trigonal Prism of the First Order, $(o\bar{h}ho)$.

bounded by six faces. Alternate solid angles are equal, three being less than 120° and three greater. The crystallographical axes bisect the edges.

IV. Trigonal prism of the first order, $\pm \left(\frac{a : \infty a : a : \infty c}{2} \right)$;
(ho $\bar{h}o$), (oh $\bar{h}o$).

When the poles are moved on the primitive circle to coincide with the didigonal axes, the resulting form is the trigonal prism of the first order, Fig. 195, bounded by three equal faces, the lateral axes terminating, two in each face, as indicated in Fig. 195.

Other forms. — Other possible positions of the poles will produce apparent holohedral forms, *i.e.* the hexagonal pyramid and prism of the second order and the base.

Forms possible to combine on crystals of this type will be —

Plus and minus ditrigonal pyramids, (**hk $\bar{i}l$**), (**ih $\bar{k}l$**).

Plus and minus ditrigonal pyramids of the first order, (**hoh \bar{l}**), (**ohh \bar{l}**).

Hexagonal pyramid of the second order, (**hh $\bar{z}ho$**).

Plus and minus ditrigonal prisms, (**hk $\bar{i}o$**), (**ih $\bar{k}o$**).

Plus and minus trigonal prisms of the first order, (**ho $\bar{h}o$**), (**oh $\bar{h}o$**).

Hexagonal prism of the second order, (**hh $\bar{z}ho$**).

Hexagonal base, (0001).

Example. — There is only one example of a substance crystallizing in this type, the mineral benitoite, $BaTiSi_3O_9$, Fig. 196.

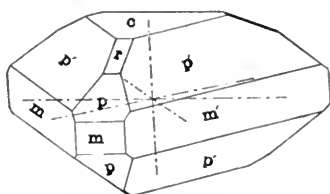

FIG. 196. — Benitoite, Combination of $p(10\bar{1}1)$, $p'(0\bar{1}11)$, $m(10\bar{1}0)$, $r(10\bar{1}2)$, $c(0001)$.

CLASS, DITRIGONAL HEMIMORPHIC

TYPE 12, DITRIGONAL POLAR

Symmetry. — The *c* axis is an axis of ditrigonal symmetry, which is also polar, with three planes of symmetry intersecting in it. The forms are derived from the ditrigonal equational type by a polar development of the *c* axis, Fig. 197.

Forms

I. Ditrigonal hemipyramids,

$$\pm u/1 \left[\frac{na : \frac{n}{n-1} a : a : mc}{4} \right]; (hk\bar{i}l), (\bar{i}khl), (hk\bar{i}\bar{l}), (i\bar{h}kl).$$

Fig. 198 represents that portion of the ditrigonal pyramid above the equatorial plane. In this hemipyramid the lateral axes

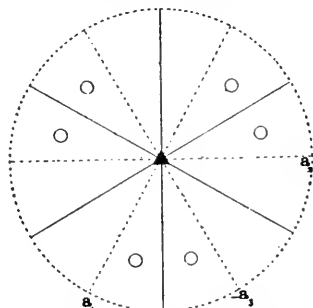

FIG. 197.—Type 12, Ditrigonal Polar.

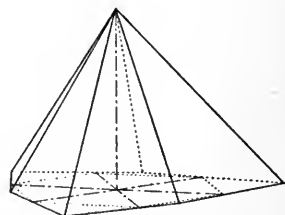

FIG. 198.—The Upper Plus Ditrigonal Hemipyramid ($hkil$).

hold the same relation to the edges as in the ditrigonal equatorial types.

II. Trigonal hemipyramids of the first order,

$$\pm u/1 \left(\frac{a : \infty a : a : mc}{4} \right); (h\bar{o}h\bar{l}), (o\bar{h}h\bar{l}), (h\bar{o}h\bar{l}), (o\bar{h}h\bar{l}).$$

The trigonal hemipyramid appears here as a new form; Fig. 199 represents the upper minus trigonal hemipyramid of the first order.

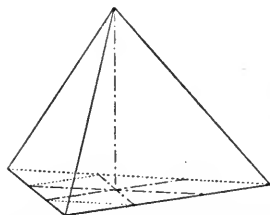

FIG. 199.—Upper Negative Trigonal Hemipyramid of the First Order, ($o\bar{h}h\bar{l}$).

Other forms in the type are similar to the forms of the ditrigonal equatorial, except the hexagonal pyramid of the second order and the base are upper and lower forms which have appeared in the dihexagonal polar type.

Combinations. — The possible forms to combine in this type are :

Upper and lower, plus and minus ditrigonal hemipyramid, ($hk\bar{i}l$), ($kh\bar{i}l$), ($hk\bar{i}l$), ($kh\bar{i}l$).

Upper and lower, plus and minus

pyramid of the second order and the base are upper

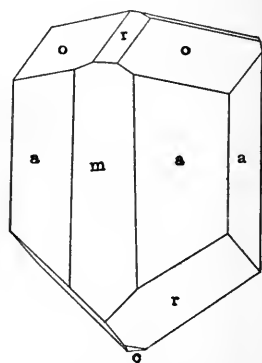

FIG. 200.—Tourmaline, a Combination of the Upper and Lower Trigonal Pyramids r ; Hexagonal Prism, Second Order a ; the Lower Base c , and the Trigonal Prism, First Order m .

trigonal hemipyramid of the first order, $(h\bar{o}hl)$, $(o\bar{h}hl)$, $(h\bar{o}l)$, $(o\bar{h}l)$.

Upper and lower hexagonal hemipyramid of the second order, $(hhzhl)$, $(hhz\bar{h}l)$.

Plus and minus ditrigonal prism, $(hkio)$, $(k\bar{h}io)$.

Plus and minus trigonal prism of the first order, $(ho\bar{h}o)$, $(o\bar{h}ho)$.

Hexagonal prism of the second order, $(hhz\bar{h}o)$.

Upper and lower base, (0001) , $(000\bar{1})$.

Example. — The common and important mineral tourmaline belongs to this type; Fig. 200 represents a combination of forms as found on this mineral.

CLASS, TRIGONAL TETARTOHEDRAL

TYPE 11, TRIGONAL EQUATORIAL

Symmetry. — Crystals of this type have an axis of trigonal symmetry, the *c* axis, and one plane of symmetry perpendicular to it, Fig. 201. The class may also be considered as tetartohedral derived by superposing type 19, scalenohedral hemihedral, upon type 13, trigonal hemihedral.

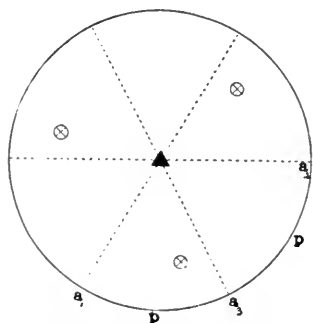

Forms

I. Trigonal pyramids of the third order,

FIG. 201. — Type 11, Trigonal Equatorial.

$$\pm r/l \left[\frac{na: \frac{n}{n-1} a : a : mc}{4} \right]; (hk\bar{i}l), (k\bar{h}il), (i\bar{k}hl), (ih\bar{k}l).$$

The faces represented by the poles in Fig. 201 bound the right plus trigonal pyramid of the third order, a form having six isosceles triangular faces. The *a* axes terminate asymmetrically in the equatorial edges, as represented in Fig. 202. There are four pyramids of the third order: the plus and minus right, two congruent forms; the plus and minus left, also two congruent forms. The rights and lefts are enantiomorphic. Fig. 203 is a minus left form.

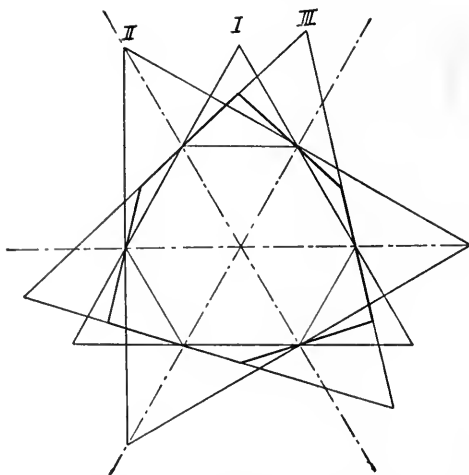

FIG. 202. — Diagram of the Equatorial Plane, showing the Relation of the Trigonal Prisms and Pyramids to the Lateral Axes.

II. Trigonal pyramids of the second order, $\pm \left(\frac{2a : 2a : a : mc}{2} \right)$; $(\overline{hh}2hl)$, $(2\overline{hhh}l)$.

When the poles in Fig. 201 are moved so as to lie on the dotted line representing the lateral axes, a new form, the trigonal pyramid of the second order, is the result, Fig. 204; a form which will not differ from the trigonal pyramids of the third or first orders in appearance, but differs in its relation to the lateral axes, which terminate in the central point of each equatorial edge and in the opposite angle, as is shown in Fig. 202.

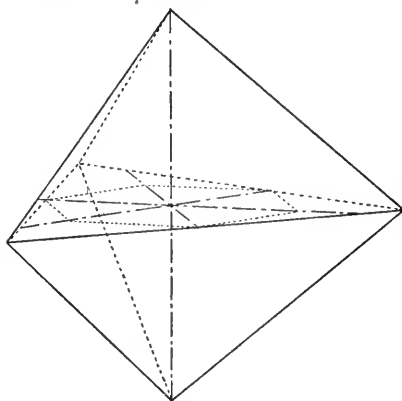

FIG. 203. — The Minus Left Trigonal Pyramid of the Third Order.

III. Trigonal prisms of the third order,

$$\pm r/l \left[\frac{na : \frac{n}{n-1} a : a : \infty : c}{2} \right]; (\overline{hk}\bar{i}o), (\overline{kh}\bar{i}o), (\overline{ik}\bar{h}o), (\overline{ih}\bar{k}o).$$

When the poles in Fig. 201 lie on the primitive circle, between the points *a*, the terminations of the lateral axes and the points *p*, the

terminations of the intermediate axes, a new form, Fig. 205, the trigonal prism of the third order, will result. When the pole is to

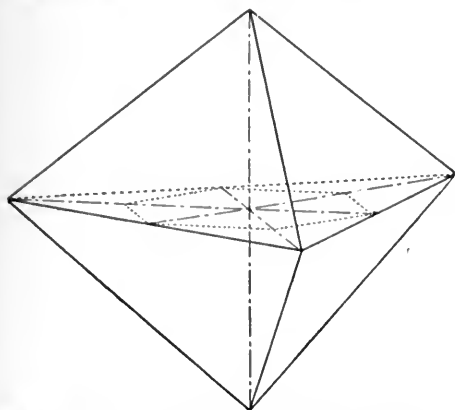

FIG. 204.—The Positive Trigonal Pyramid of the Second Order, $(\overline{hh\bar{2}hl})$.

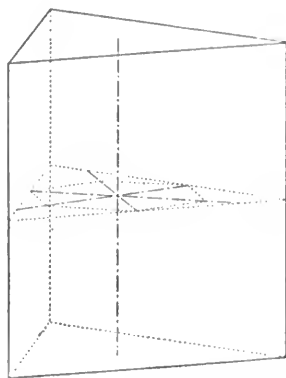

FIG. 205.—The Negative Left Trigonal Prism of the Third Order, $(i\overline{kh}l)$.

the right of the point p , it is a right form; when to the left of p , it is a left form; when between a and a_3 , a plus, and between a_3 and a_2 , a minus form.

IV. Trigonal prisms of the second order, $\pm \left(\frac{2a : 2a : a : \infty c}{2} \right)$; $(\overline{hh\bar{2}ho})$, $(2\overline{hhho})$.

When the poles are at the points a , Fig. 201, a new form, Fig. 206, the trigonal prism of the second order, will result, in which the lateral axes terminate in the central point of the face and bisect the opposite edges, as illustrated in Fig. 206. The relation of the trigonal pyramids and prisms to the lateral axes is shown in Fig. 202, which is a plan of the equatorial plane.

Other forms. — All other positions of the poles will yield forms of the ditrigonal equatorial type.

The possible forms to combine in this type will be:

Right and left plus and minus trigonal pyramids of the third order, $(\overline{hki}l)$, $(\overline{khi}l)$, $(i\overline{hkl})$, $(i\overline{kh}l)$.

Plus and minus trigonal pyramids of the second order, $(\overline{hh\bar{2}hl})$, $(2\overline{hhhl})$.

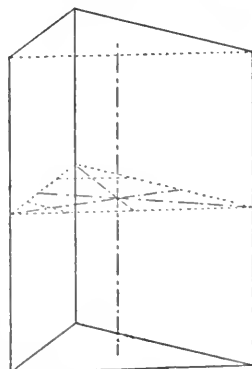

FIG. 206.—The Plus Trigonal Prism of the Second Order, $(\overline{hh\bar{2}ho})$.

Plus and minus trigonal pyramid of the first order, ($h\bar{o}h\bar{l}$), ($o\bar{h}h\bar{l}$).

Right and left plus and minus trigonal prisms of the third order, ($hk\bar{i}o$), ($kh\bar{i}o$), ($ihko$), ($ikho$).

Plus and minus trigonal prisms of the second order, ($hh\bar{z}h\bar{o}$), ($zh\bar{h}h\bar{o}$).

Plus and minus trigonal prisms of the first order, ($h\bar{o}h\bar{o}$), ($o\bar{h}h\bar{o}$).

Base, (0001).

Examples. — As yet there are no representatives of this type.

CLASS, TRAPEZOHEDRAL TETARTOHEDRAL

TYPE 10, TRIGONAL HOLOAXIAL

Symmetry. — Crystals of this type are symmetrical in regard to one trigonal axis of symmetry, the c axis, and three digonal axes, the a axes. Fig. 207 illustrates the symmetry of the type.

It may also be considered as a tetartohedral class, and the forms are derived by superimposing the rhombohedral hemihedrons, type 19, upon the trapezohedral hemihedrons, type 16, and extending the faces not thus marked, as below :

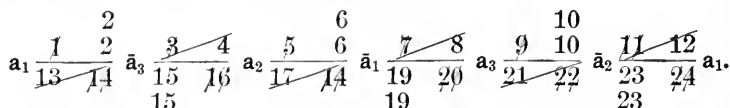

In the rhombohedral method of selection, alternating dodecants above and below the equator are crossed out and suppressed; in the trapezohedral method every other face above and below the equator is crossed out, as suppressed. There will remain of the 24 faces of the dihexagonal pyramid, represented above, 6 faces, 2, 6, and 10 above, and 15, 19, and 23 below the equator. When this method of selection is compared with the rhombohedral tetartohedral method, page 97, it will be seen that there the faces below lie symmetrically between those above, but here they are not symmetrically located, as 15 is nearer 2 than to 6, which in the new form will produce a long inclined edge between 6 and 15 and a short edge between 2 and 15. These corresponding edges are equal

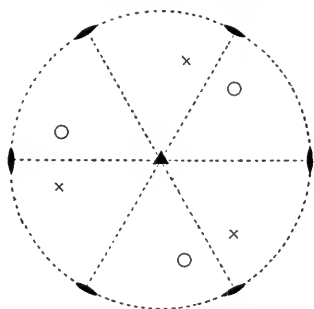

FIG. 207. — Type 10, Trigonal
Holoaxial.

These corresponding edges are equal

in type 15, forming the rhombohedron of the third order. As in all other tetartohedral classes, there are here also four new forms. In the selection above, face 2 and those corresponding are taken, forming the plus right form. The selection may be so arranged that 1, or 13, or 14, and corresponding faces should be selected; 2 and 13 are the plus and minus right congruent forms and 1 and 14 are the plus and minus left congruent forms. By applying the method as above in turn to each of the holohedral forms of type 20, the new forms of this type will be produced.

Forms

I. Trigonal trapezohedrons,

$$\pm r/1 \left[\frac{na : \frac{n}{n-1} a : a : mc}{4} \right]; \kappa\tau(\overline{hkil}), \kappa\tau(\overline{khil}), \kappa\tau(\overline{ihkl}), \kappa\tau(\overline{ikh1}).$$

From the dihexagonal pyramid the four trigonal trapezohedrons are derived, of which the plus right is represented in Fig. 208, and the plus left in Fig. 209. There are six equal polar edges, three at each pole, three long and three short median zigzag edges, which are bisected by the terminations of the *a* axes.

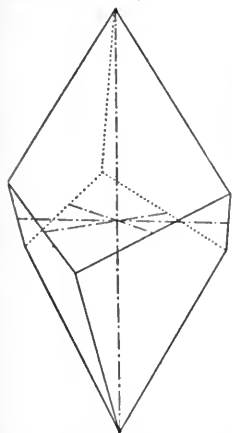

FIG. 208.—The Positive Right Trigonal Trapezohedron.

II. All other positions of the poles in Fig. 207 will yield forms already described, as the trigonal trapezohedron is the only new form of the type. The possible forms to combine in the type are:

Plus and minus right and left trigonal trapezohedrons, $\kappa\tau(\overline{hkil})$, $\kappa\tau(\overline{khil})$, $\kappa\tau(\overline{ihkl})$, $\kappa\tau(\overline{ikh1})$.

Plus and minus rhombohedron of the first order, $\kappa\tau(\overline{hohl})$, (\overline{ohhl}) .

Plus and minus trigonal pyramid of the second order, $\kappa\tau(\overline{hhzh1})$, $\kappa\tau(\overline{zhhh1})$.

Plus and minus right and left ditrigonal prisms, $\kappa\tau(\overline{hkio})$, $\kappa\tau(\overline{khio})$, $\kappa\tau(\overline{ihko})$, $\kappa\tau(\overline{ikho})$.

Plus and minus trigonal prisms second order, $\kappa\tau(\overline{hhzho})$, $\kappa\tau(\overline{zhhhho})$.

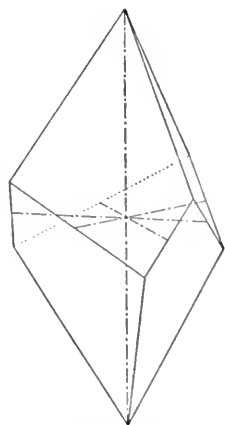

FIG. 209.—The Plus Left Trapezohedron.

Hexagonal prism first order, $\kappa\tau$ (\overline{hoho}).

Base, (0001).

Examples. — Quartz, SiO_2 , crystallizes in this type, of which Fig. 210 is a combination of the hexagonal prism, first order, plus

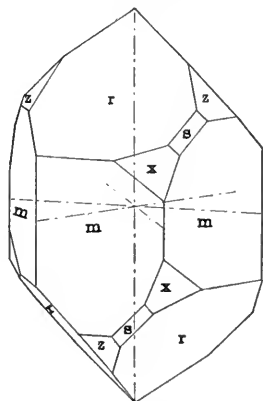

FIG. 210.—Right-handed Quartz: Combination of $m(10\bar{1}0)$, $r(10\bar{1}1)$, $z(01\bar{1}1)$, $s(11\bar{2}1)$, $x(51\bar{6}1)$.

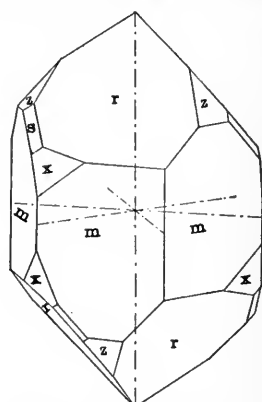

FIG. 211.—Left-handed Quartz, $m(10\bar{1}0)$, $r(10\bar{1}1)$, $z(01\bar{1}1)$, $s(2\bar{1}\bar{1}1)$, $x(6\bar{5}\bar{1}1)$.

and minus rhombohedrons, first order, plus trigonal pyramid, and the right plus trigonal trapezohedron, — a right-hand crystal. Fig. 211 is a left-hand crystal. Cinnabar, HgS , also belongs here.

CLASS, TRIGONAL HEMIMORPHIC

TYPE 9, TRIGONAL POLAR

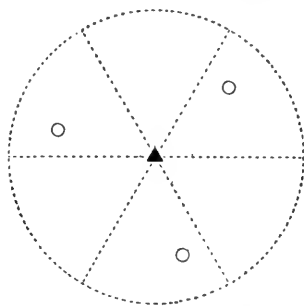

FIG. 212.—Type 9, Trigonal Polar.

Symmetry. — Crystals of this type possess one axis of trigonal symmetry, the c axis, Fig. 212. The type is a polar development of the trigonal equatorial, in which the hemitrigonal pyramids may occur independently, yielding two new forms.

Forms

I. Trigonal hemipyramids of the third order,

$$\pm r/1, u/1 \left[\frac{na : \frac{n}{n-1} : a : mc}{8} \right]; (\overline{hkil}), (kh\bar{u}), (\overline{ikh\bar{l}}), (\overline{ih\bar{k}l}), (hk\bar{i}\bar{l}), (kh\bar{i}\bar{l}), (\overline{ikh\bar{l}}).$$

Derived from the trigonal pyramid of the third order there are eight trigonal hemipyramids, of which Fig. 213 represents the upper left minus hemipyramid, and the poles in Fig. 212 are of the upper right plus form.

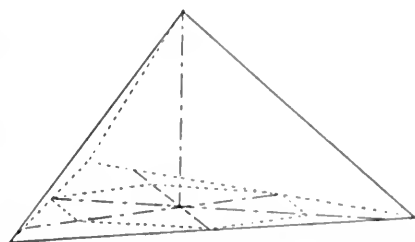

FIG. 213.—The Upper Left Negative Trigonal Hemipyramid of the Third Order.

II. Trigonal hemipyramids of the second order,

$$\pm u/1\left(\frac{2a : 2a : a : mc}{4}\right); (hhzhl), (hh\bar{z}hl), (zh\bar{h}hl), (zh\bar{h}hl).$$

There are four trigonal hemipyramids of the second order, derived from the trigonal pyramid of the second order, all of which may occur independently. Fig. 214 is the upper minus trigonal hemipyramid of the second order.

The forms possible to combine in this type are as follows :

Plus and minus right and left upper and lower hemipyramids of the third order, $(hk\bar{i}l)$, $(k\bar{h}il)$, $(i\bar{h}kl)$, $(i\bar{k}hl)$, $(h\bar{k}il)$, $(k\bar{h}il)$, $(i\bar{h}kl)$, $(i\bar{k}hl)$.

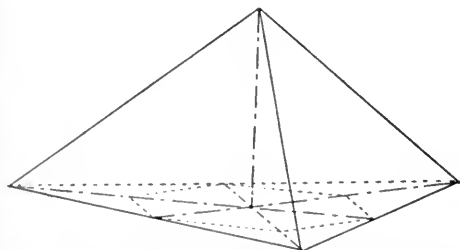

FIG. 214.—The Upper Negative Trigonal Hemipyramid of the Second Order.

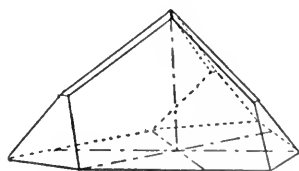

FIG. 215.—Combination of Forms showing the Polar Development of Crystals of Sodium Periodate.

Plus and minus upper and lower trigonal hemipyramids of the second order, $(hhzhl)$, $(zh\bar{h}hl)$, $(hh\bar{z}hl)$, $(zh\bar{h}hl)$.

Plus and minus upper and lower trigonal hemipyramids of the first order, $(ho\bar{h}l)$, $(o\bar{h}hl)$, $(ho\bar{h}l)$, $(o\bar{h}hl)$.

Plus and minus right and left trigonal prisms of the third order, $(hk\bar{i}o)$, $(i\bar{h}ko)$, $(k\bar{h}io)$, $(i\bar{k}ho)$.

Plus and minus trigonal prisms of the second order, $(ho\bar{h}o)$, $(o\bar{h}ho)$.

Plus and minus trigonal prisms of the first order, $(hhzho)$, $(zh\bar{h}ho)$.

Upper and lower base, (0001) , $(000\bar{1})$.

Example. — Sodium periodate, $\text{NaIO}_4 \cdot 3 \text{H}_2\text{O}$, crystallizes in trigonal hemipyramids. Fig. 215 is a combination of two plus upper hemipyramids of the second order and one of the first order with the lower base.

Crystalline Characters

Like the tetragonal system, the hexagonal system has but one variable crystalline character, the axial ratio, $\frac{c}{a}$. This is calculated in a similar way, by means of the angle between the basal pinacoid and the pyramid face of the first or second order.

I. When the pyramid of the second order is used,

$$\frac{c}{a} = \tan (0001)_\lambda (1122).$$

Example. — In the mineral beryl, the angle between the normal to the base and that of the unit pyramid of the second order is $26^\circ 31'$, $\frac{c}{a} = 0.4988^+$, and as $a = 1$, $c = 0.4988^+$, which is the unit of measurement on the c axis.

II. When the pyramid of the first order is used,

$$\frac{c}{a} = \tan (0001)_\lambda (1011) \times 1/2\sqrt{3}.$$

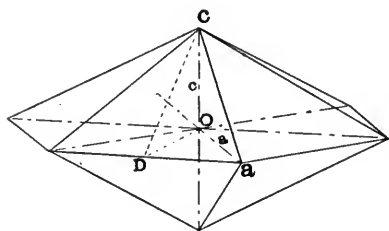

FIG. 216.

Figure 216, $\text{CO} = c$ and $\text{OA} = a = 1$.

$$\tan \text{CDO} = \frac{\text{CO}}{\text{DO}};$$

$$\text{CO} = \tan \text{CDO} \times \text{DO}.$$

In the triangle aDO , right-angled at D , and $\text{DOa} = 30^\circ$, $\text{DO} = 1/2\sqrt{3}$, then $c = \tan \text{CDO} \times 1/2\sqrt{3}$, but the angle CDO

is equal to the angle between the poles of the base and the unit pyramid of the first order, $(0001)_\lambda (1011)$.

In the mineral beryl the angle $0001_\lambda 1011$ is $29^\circ 56'$,

$$c = \tan 29^\circ 56' \times 1/2\sqrt{3}.$$

$$\text{Log } \tan 29^\circ 56' = 9.760272 + 10$$

$$\text{Log } 1/2\sqrt{3} = \bar{1}.937530$$

$$\text{Log } c + 10 = 9.697802$$

$$c = .4988^+$$

CHAPTER VI

THE ORTHORHOMBIC, MONOCLINIC, AND TRICLINIC SYSTEMS

THE ORTHORHOMBIC SYSTEM

CRYSTALS of this system possess three crystallographical axes; all at right angles, none of which are interchangeable. The vertical axis is represented by \bar{c} . The longer lateral axis or macro-axis is represented by \bar{b} and is placed horizontally from right to left, while the short or brachy-axis, \bar{a} , is at right angles to \bar{b} . Included in the system are three types all of which have at least one axis of digonal symmetry. The forms fall into three groups, according to the relation of their faces to the axes. If the faces cut all three axes, it is a pyramid and there will be no 0 in its indices, as here there are no pyramids or prisms of the second order; if the face cuts two axes and is parallel to the third, it is a prism and there will be one 0 in its indices; when parallel to a lateral axis it is a dome and receives the name of the lateral axis to which it is parallel, as macrodome. A dome is a prism parallel to a lateral axis. When the face is parallel to two axes, it is a pinacoid and there will be two zeros in its indices; when parallel to the lateral axes it is a basal pinacoid; when parallel to c and one of the lateral axes, it takes the name of the lateral axis to which it is parallel, as brachypinacoid.

CLASS, ORTHORHOMBIC, HOLOSMMETRIC, OR HOLOHEDRAL

TYPE 8, DIDIGONAL EQUATORIAL

Crystals of this type possess three didigonal axes, corresponding to the crystallographical axes; three planes, the diametral planes, and a center of symmetry, Fig. 217. The largest number of faces possible on any crystal form of the type will be 8, one in each octant into which the three planes of symmetry, Fig. 218, divide space.

Forms

I. Orthorhombic pyramids, $\bar{n}\bar{a} : \bar{b} : m\bar{c}$; (hkl) .

The poles in Fig. 217 represent the orthorhombic pyramid; it is bounded by 8 similar scalene triangular faces, which inclose space,

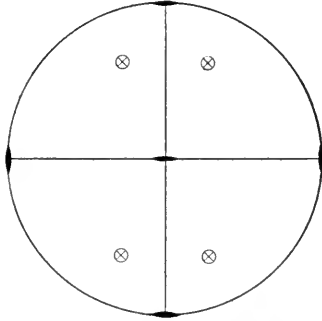

FIG. 217. — Type 8, Didigonal Equatorial.

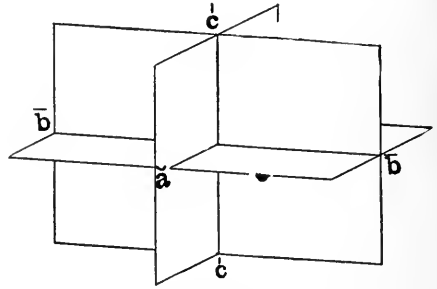

FIG. 218. — The Orthorhombic Axes and Planes of Symmetry.

Fig. 219. The crystallographical axes terminate in the tetrahedral angles. There are three series of pyramids:

a. The unit series, $\bar{a} : \bar{b} : m\bar{c}$, (hhl) , where the variable lies on the \bar{c} axis; Fig. 220 represents the unit series of pyramids.

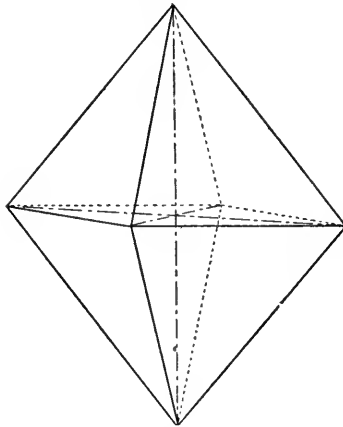

FIG. 219. — The Unit Pyramid of Barite.

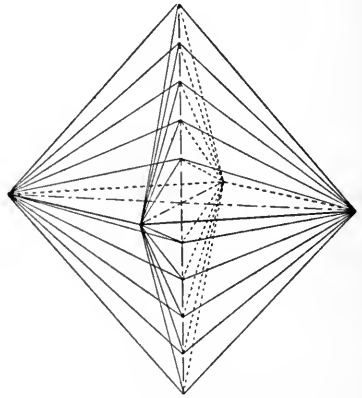

FIG. 220. — The Unit Series of Pyramids.

b. Macro series of pyramids, $\bar{a} : n\bar{b} : \bar{c}$, (hlh) , when the intercept on \bar{b} is greater than unity.

c. Brachy series of pyramids, $\bar{n}\bar{a} : \bar{b} : \bar{c}$, (lhh) , when the intercept on the \bar{a} axis is greater than unity.

II. Prisms, $n\bar{a} : \bar{b} : \infty c$; (hko).

Prisms are parallel to the c axis; the poles of Fig. 217 will lie on the primitive circle between the digonal axes. When the pole is nearer \bar{a} the form will be of the macro series, $\bar{a} : n\bar{b} : \infty c$, as its intercept on \bar{b} will be larger than unity, and when near \bar{b} , the form will be of the brachy series; Fig. 221 is the unit prism, which is the limiting form connecting the two series.

III. Domes. Macro series of domes, $n\bar{a} : \infty \bar{b} : m\bar{c}$; (hok).

When the poles lie in the diametral plane containing the c and \bar{a} axes, the faces will be parallel to the macro axis, and the form will be a macrodome Fig. 222, an open form bounded by four similar faces. There will be a series of macrodomes the angles of which and the intercepts on the axes will depend upon the position of the poles.

Brachy series of domes, $\infty \bar{a} : n\bar{b} : m\bar{c}$; (ohk).

When the poles lie in the plane of symmetry containing the c

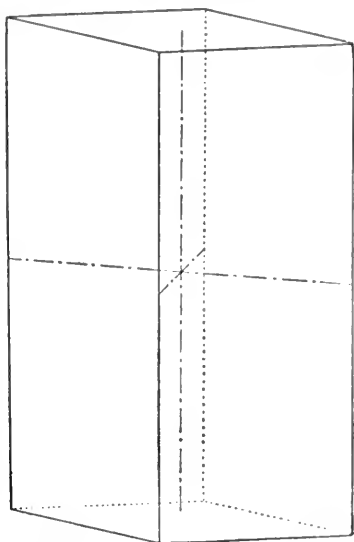

FIG. 221. — The Unit Prism of Barite.

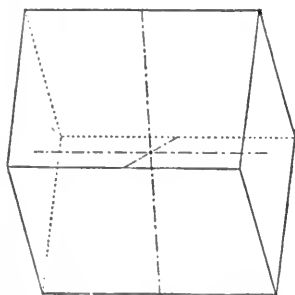

FIG. 222. — The Unit Macro-dome of Barite.

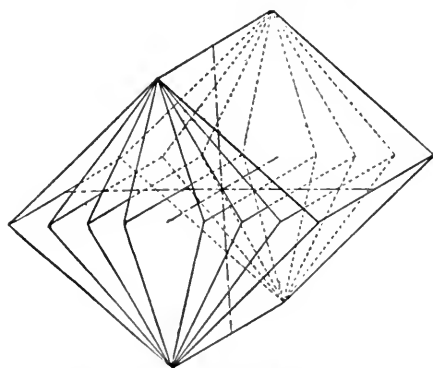

FIG. 223. — The Brachy Series of Domes.

and \bar{b} axes, the faces will be parallel to the brachyaxis, and the form will be a brachydome, of which there is also a series, Fig. 223.

IV. **Pinacoids.** — Three other positions of the poles are possible, which represent the fixed forms, that is when the poles take the position of the angles of the triangle, or coincide with the crystallographical axes.

Basal pinacoid, $\infty \bar{a} : \infty \bar{b} : \bar{c}$, (001).

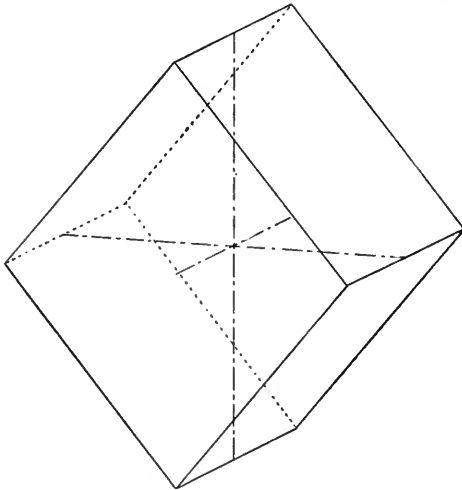

FIG. 224. — The Unit Brachydome of Barite.

When the pole coincides with the \bar{c} axis, the face will be parallel to \bar{a} and \bar{b} , the form consisting of two faces, one above and one below the equatorial plane, which will produce the basal pinacoid.

Macropinacoid, $\bar{a} : \infty \bar{b} : \infty \bar{c}$, (100).

Here the pole coincides with the \bar{a} axis, when the face is parallel to \bar{b} and \bar{c} .

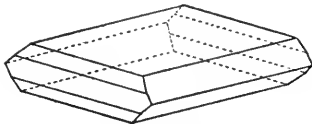

FIG. 226. — Barite.

Brachypinacoid, $\infty \bar{a} : \bar{b} : \infty \bar{c}$, (010).

Here the pole coincides with the \bar{b} axis and the faces are parallel to \bar{a} and \bar{c} ; Fig. 225 represents the three pinacoids in combination.

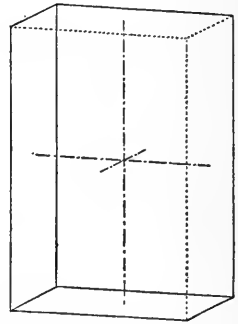

FIG. 225. — Combination of the Three Pinacoids.

Forms in combination. — The possible forms to combine in this type therefore are :

Pyramids, series (hkl).

Prisms, series (hko).

Macrodome, series (hok).

Brachydome, series (ohk).

Basal pinacoid, (001).

Macropinacoid, (100).

Brachypinacoid, (010).

Examples. — A large number of, and especially important, rock-forming minerals crystallize in this type:

Olivine, $(\text{Mg,Fe})_2\text{SiO}_4$.Enstatite, MgSiO_3 .Aragonite, CaCO_3 .Topaz, $\text{Al}[\text{Al}(\text{O,F}_2)]\text{SiO}_4$.Barite, BaSO_4 .

Fig. 226 is a combination of the base, brachydome, macrodome, and macropinacoid in barite.

CLASS, ORTHORHOMBIC HEMIMORPHIC

TYPE 7, DIDIGONAL POLAR

Symmetry. — Crystals of this type possess one didigonal axis, the \bar{c} axis, and two planes of symmetry intersecting in the \bar{c} axis, Fig. 227. It is a polar development of the didigonal equatorial, with a loss of all the symmetry lying in the equatorial plane of that type.

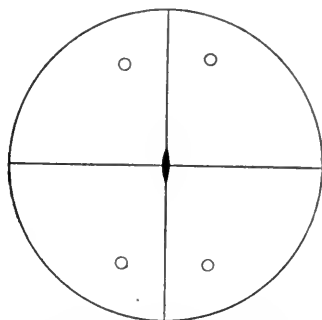

FIG. 227. — Type 7, Didigonal Polar.

Forms

I. Hemipyramids, $u/1\left(\frac{n\bar{a} : \bar{b} : m\bar{c}}{2}\right)$;
(hkl), ($h\bar{k}l$).

There would be upper and lower pyramids of each series, Fig. 228.

II. Domes. Macrodomes, $u/1\left(\frac{n\bar{a} : \infty \bar{b} : m\bar{c}}{2}\right)$; (hok), ($hok\bar{}$),
Fig. 229.

Brachydomes, $u/1\left(\frac{\infty 2 : nb : mc}{2}\right)$; (ohk), ($oh\bar{k}$), Fig. 230.

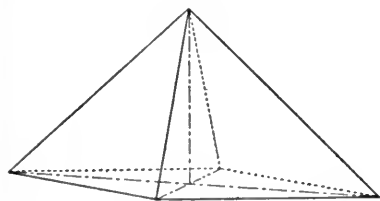

FIG. 228. — The Upper Hemipyramid.

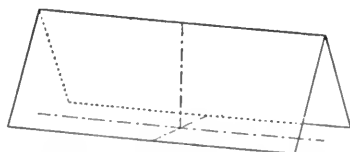

FIG. 229. — The Upper Macrodome.

Both domes would be modified by the symmetry, yielding hemidomes, while the prisms would suffer no apparent change.

III. Of the three pinacoids, the base would yield hemi forms, the upper and lower base, $u/1\left(\frac{\infty \bar{a} : \infty \bar{b} : c}{2}\right)$, (001) , $(00\bar{1})$.

Possible forms to combine in the type would be :

Pyramids upper and lower, (hkl) , $(h\bar{k}l)$.

Prisms, two series, (hko) .

Domes ; upper and lower macrodomes, (hok) , $ho\bar{k}$.

Domes ; upper and lower brachydomes, (ohk) , $(oh\bar{k})$.

Macropinacoid, (100) .

Brachypinacoid, (010) .

Upper and lower base (001) , $(00\bar{1})$.

Examples. — Calamine, $ZnSiO_3, 2 H_2O$. Fig. 231 represents a combination of two upper hemimacro- and brachydomes, the

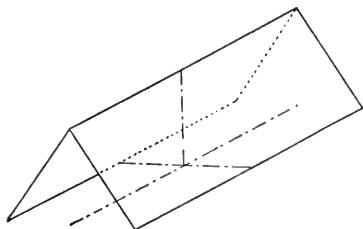

FIG. 230. — The Upper Brachydomes.

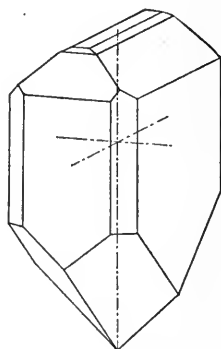

FIG. 231. — Calamine.

unit prism, the lower unit hemipyramid, the macro- and brachypinacoids, and the upper base.

Struvite, $NH_4MgPO_4, 6 H_2O$, also crystallizes in this type.

CLASS, SPHENOIDAL HEMIHEDRONS

TYPE 6, DIGONAL HOLOAXIAL

Symmetry. — Crystals of this type possess three axes of digonal symmetry corresponding to the crystallographical axes, but no planes of symmetry. Fig. 232 illustrates the symmetry of the type.

Forms

I. Sphenoids, $r/1\left(\frac{n\bar{a} : \bar{b} : mc}{2}\right)$; $\kappa(hkl), \kappa(h\bar{k}l)$.

The poles of Fig. 232 represent the general form of the type.

The right sphenoid, with four similar scalene triangular faces, Fig. 233 and Fig. 234, is the complementary left form.

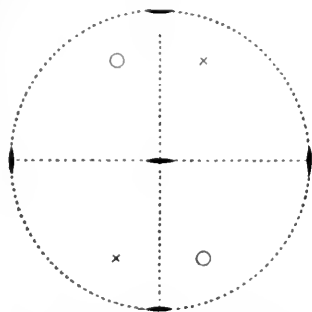

FIG. 232. — Type 6, Digonal Holoaxial.

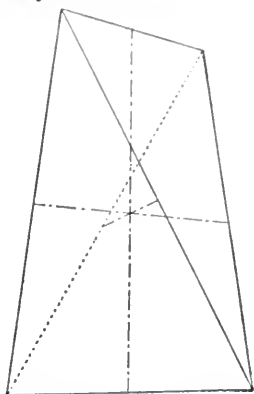

FIG. 233. — The Right Sphenoid.

Other forms are similar in appearance to those of type 8.

Forms possible to combine in this type will therefore be:

Right and left sphenoids, $\kappa(hkl)$, $\kappa(h\bar{k}l)$.

Orthorhombic prisms, (hko) . Macropinacoids, (100) .

Macrodomes, (hok) . Brachypinacoids, (010) .

Brachydomes, (ohk) . Basal pinacoid, (001) .

Examples. — Sulphur, S, Fig. 235, represents a combination of the right and left sphenoids and the base on sulphur.

Epsomite, $MgSO_4 \cdot 7H_2O$, Fig. 236, is a combination of the prism and right sphenoid as found on crystals of this mineral.

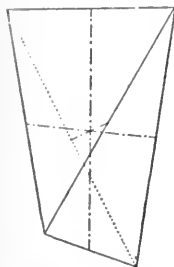

FIG. 234. — The Left Sphenoid.

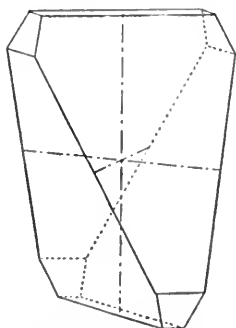

FIG. 235. — Sulphur.

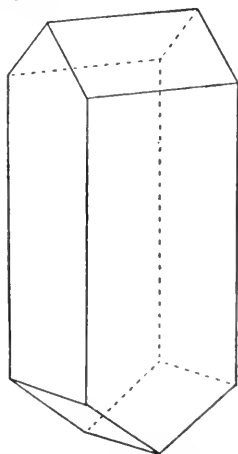

FIG. 236. — Epsomite: Combination of (110) and (111) .

Crystalline Characters

In the orthorhombic system, where the unit on each axis is a different one, there are two axial ratios, $\frac{a}{b}$ and $\frac{c}{b}$, b being the unit of comparison, or as they are generally written, $\bar{a} : \bar{b} : \bar{c} = .8152^+ 1 : 1.31359^+$, the axial values of barite.

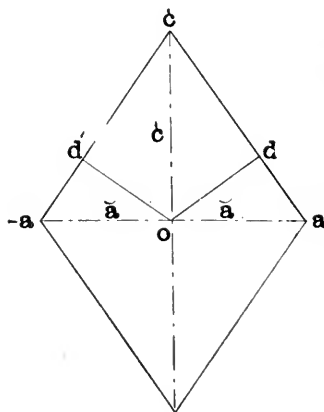

FIG. 237.

On calculating the axial ratios it will be necessary to measure the angle of the unit prism, or the angle between the unit prism and either the macro- or brachypinacoid, when \bar{a} in terms of \bar{b} may be calculated. To determine \bar{c} , the angle of the unit dome or the angle between the dome and a pinacoid must be measured.

Example. — In the mineral staurolite, the angle $100_{\wedge}110 = 25^{\circ} 20'$; as this is the angle between the poles, the actual angle of the right-angled triangle is $25^{\circ} 20'$, with the side \bar{a}

opposite, therefore, $\tan 25^{\circ} 20' = \frac{a}{b} = \frac{a}{1} = .4734^+$, as $b = 1$.

In calculating the value of \bar{c} , the angle $101_{\wedge}\bar{1}01 = 110^{\circ} 32'$, which being the angle between the poles, the actual angle between the faces, Fig. 237, $cao = 1/2 \text{ dod}' = 55^{\circ} 16'$; $\frac{c}{a} = \tan 55^{\circ} 16'$, $c = \bar{a} \times \tan 55^{\circ} 16'$; $\bar{a} = .4734$.

$$\text{Log } \tan 55^{\circ} 16' = 10.159083 - 10$$

$$\text{Log } .4734 = \bar{1}.675228$$

$$\text{Log } c = \overline{9.834311} - 10$$

$$c = .6829$$

Axial ratio of staurolite, $\bar{a} : \bar{b} : \bar{c} = .8152 : 1 : .6829$.

THE MONOCLINIC SYSTEM

The monoclinic system includes all those crystals referable to three axes, two of which, \bar{c} the vertical, and \bar{b} the orthoaxis, are at right angles; the third, or clinoaxis, is at right angles to \bar{b} and inclined to \bar{c} , and is designated by \bar{a} . Here the three diametral planes

no longer divide space into eight equal octants, but into octants of two different sizes, four of which are large, or obtuse, and four smaller, or acute. The two upper front and the two lower back octants are large and designated - octants; the smaller are the + octants. As the inclination of \hat{a} to \hat{c} varies with the substance, the angle between these two axes, measured in the + octants is designated by β , and is therefore less than 90° , which added to the two axial ratios $\frac{a}{b}$ and $\frac{c}{b}$ make three crystalline characters for the system.

CLASS, HOLOHEDRAL (HOLOSMMETRIC)

TYPE 5, DIGONAL EQUATORIAL

Symmetry. — Crystals of this type possess one digonal axis, the \hat{b} axis; one plane of symmetry, the equatorial plane, at right angles to the \hat{c} axis and containing \hat{a} and \hat{c} , and a center. Figure 238 represents the relation of the axes and plane of symmetry, and also the general position of the monoclinic crystals in relation to the ob-

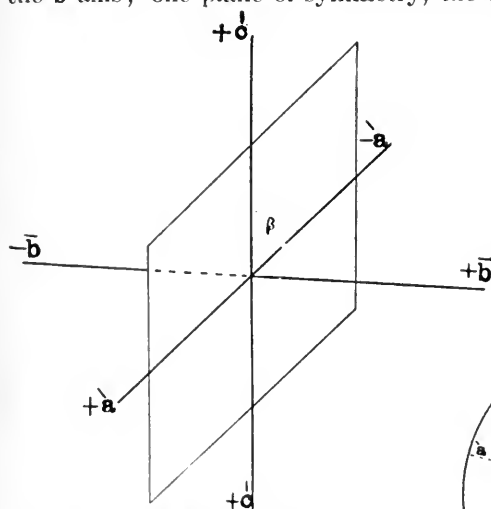

FIG. 238. — The Monoclinic Axes and Plane of Symmetry.

server. Figure 239 representing the symmetry of the type, it differs from others in that the \hat{b} axis and not \hat{c} is perpendicular to the plane of the paper. In viewing a crystal of this type held in the general position, the equatorial plane will be vertical.

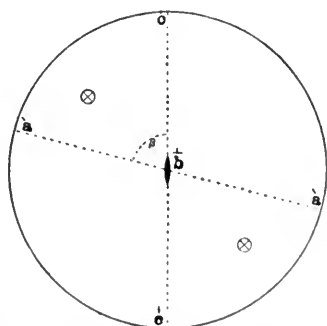

FIG. 239. — Type 5, Digonal Equatorial.

Forms

I. Monoclinic pyramids differ from those heretofore considered, as the octants subtended by the faces are large and small, yielding faces, represented by the same parameters or indices, of two sizes, of which the larger faces form the minus and the smaller form the plus pyramids. Monoclinic pyramids do not inclose space;

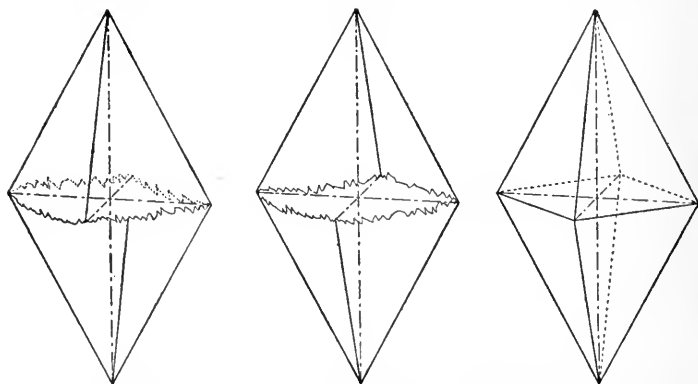

FIG. 240. — The Minus Pyramid. The Plus Pyramid. Combination of the Plus and Minus Pyramid.

the combination of the plus and minus pyramids is equivalent to a single orthorhombic pyramid, and incloses space, Fig. 240.

As in the orthorhombic system, there are three series of pyramids holding the same relation to the axes as in that system.

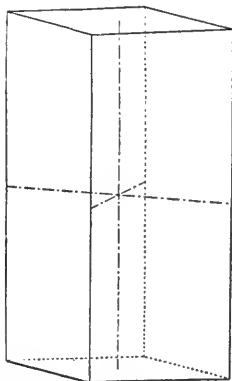

FIG. 241. — The Unit Monoclinic Prism.

Unit series of pyramids, $\pm \dot{a} : \dot{b} : m\dot{c}$, (hhl) , $(\bar{h}hl)$.

Ortho series of pyramids, $\pm \dot{a} : n\dot{b} : m\dot{c}$, (hkl) , $(\bar{h}kl)$.

Cliно series of pyramids, $\pm n\dot{a} : \dot{b} : m\dot{c}$, (khl) , $(\bar{k}hl)$.

The unit or fundamental pyramid is the connecting link between the three series. When the form represented by the spherical projection is a pyramid, the poles will fall within the triangle, Fig. 239.

II. Prisms. — When the poles lie in the circle at right angles to the \dot{c} axis, the form is a prism, of which there are two series; when the pole is nearer the \dot{b} axis, it is a prism of the cliно series, $n\dot{a} : \dot{b} : \infty \dot{c}$, (hko) . When

its position is nearer the extremity of the \bar{a} axis, it is of the ortho series, $\bar{a} : \bar{nb} : \infty \bar{c}$, ($\bar{k}ho$). Prisms are not plus and minus forms, as each face subtends two octants, one above and one below, Fig. 241.

III. Clinodome, $\infty \bar{a} : \bar{nb} : \bar{mc}$, (ohl).

When the pole lies in the plane at right angles to the \bar{a} axis, the faces are parallel to the clinoaxis and the form is the clinodome.

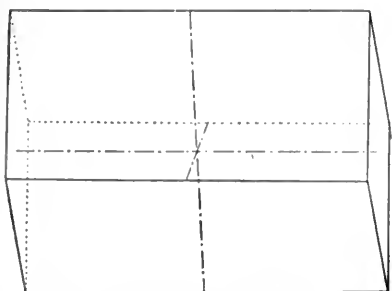

FIG. 242.—The Plus and Minus Orthodomes.

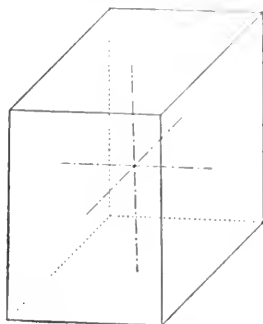

FIG. 243.—Combination of the Three Pinacoids.

IV. Orthodome.— If the poles lie in the equatorial plane the faces will be parallel to the orthoaxis and the form is the orthodome, of which there are two forms: the plus orthodome, $\bar{a} : \infty \bar{b} : \bar{mc}$, (\bar{hol}), formed by the two faces subtending the four small octants; and the minus orthodome, $\bar{a} : \bar{b} : \bar{mc}$, (hol), formed by the two faces subtending the four large octants, Fig. 242.

V. Orthopinacoid, $\bar{a} : \infty \bar{b} : \infty \bar{c}$, (100), when the poles lie in the plane of symmetry at 90° from \bar{c} .

VI. Clinopinacoid, $\infty \bar{a} : \bar{b} : \infty \bar{c}$, (010), when the poles lie on the \bar{b} axis.

VII. Basal pinacoid, $\infty \bar{a} : \infty \bar{b} : \bar{c}$, (001), when the poles lie on the c axis. Figure 243 is a combination of the three pinacoids.

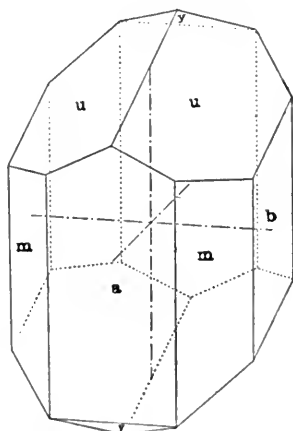

FIG. 244.—Combination of $m(110)$, $a(100)$, $b(010)$, $u(111)$, and $y(\bar{1}01)$, in Augite.

Combinations.— The possible forms to combine in this type are:

Pyramids, three series, plus and minus, ($\bar{h}kl$), (hkl).

Prisms, two series, (hko).

Ortho series of domes, plus and minus, ($\bar{h}ok$), (hok).

Clino series of domes, (ohk).

Orthopinacoid, (100).

Clinopinacoid, (010).

Basal pinacoid, (001).

Examples. — Some of the most important rock-forming minerals are members of this type, as :

Orthoclase, $KAlSi_3O_8$.

Epidote, $HCa_2Al_3Si_3O_{13}$.

Augite.

Gypsum, $CaSO_4, 2H_2O$.

Amphibole.

Fig. 244 represents a combination of the unit prism, (110), orthopinacoid, (100), clinopinacoid, (010), minus unit pyramid, (111), and the plus orthodome, ($\bar{1}01$), of augite.

CLASS, MONOCLINIC HEMIMORPHIC

TYPE 4, DIGONAL POLAR

Symmetry. — Crystals of this type possess one digonal axis of symmetry, the \bar{b} axis, Fig. 245. The forms may be considered as pro-

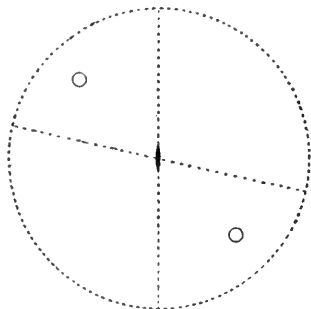

FIG. 245.—Type 4, Digonal Polar.

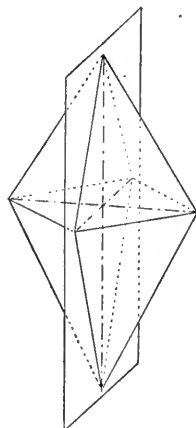

FIG. 246.

duced by a polar development of type 5, along the orthoaxis; thus the plane and center of symmetry is lost, and yielding hemi forms either side of the plane of symmetry each of which may occur independently, Fig. 246.

Forms

The new forms would be :

I. Right and left plus and minus hemipyramids, of two faces each, (hkl) , $(\bar{h}\bar{k}l)$, (hkl) , (hkl) , Fig. 247.

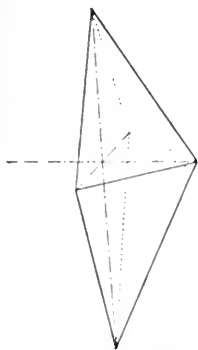

FIG. 247.—The Right Plus and Minus Hemipyramids.

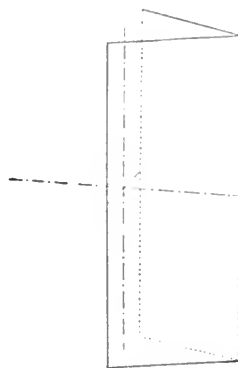

FIG. 248.—Right Hemiprism.

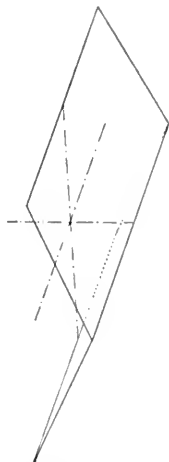

FIG. 249.—The Right Hemiclinodome.

II. Right and left hemiprisms of two faces each, (hko) , $(\bar{h}k\bar{o})$, Fig. 248.

III. Right and left hemiclinodome of two faces each, (ohk) , $(\bar{o}h\bar{k})$, Fig. 249.

IV. Right and left clinopinacoid, (010) , $(0\bar{1}0)$.

The orthodome and the ortho and basal pinacoids are not modified, and combine with the above new forms on crystals of this type.

Examples.—A number of organic compounds crystallize in this type, as, tartaric acid, $C_2H_6O_6$.

Fig. 250 is a combination of the right and left clinopinacoids, right and left prism, orthopinacoid and left clinodome on milk sugar.

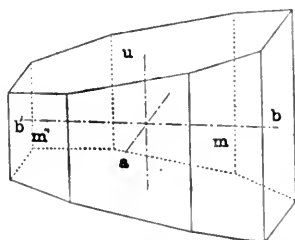

FIG. 250.—Milk Sugar: Combination of b (010), b' (0 $\bar{1}$ 0), m (110), m''' ($\bar{1}$ 10), u (011), and a (100)

CLASS, DOMATIC HEMIHEDRONS

TYPE 3, EQUATORIAL

Symmetry. — Crystals of this type possess a plane of symmetry only, Fig. 251. They may be considered as hemihedrons formed

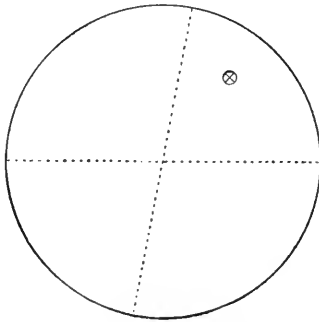

FIG. 251. — Type 3, Equatorial.

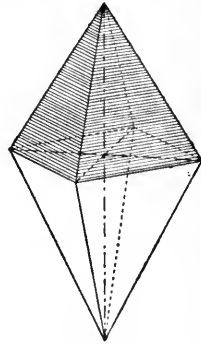

FIG. 252.

by selecting pairs of faces of type 5, which meet in the equatorial plane, as the shaded faces of the minus pyramid of Fig. 252.

Forms

I. Upper and lower plus and minus hemipyramids of each series of two faces each, $\pm \left(\frac{na : b : mc}{2} \right) u/1$, $\kappa(hkl)$, $\kappa(h\bar{k}l)$, $\kappa(hk\bar{l})$, $\kappa(h\bar{k}\bar{l})$, Fig. 253.

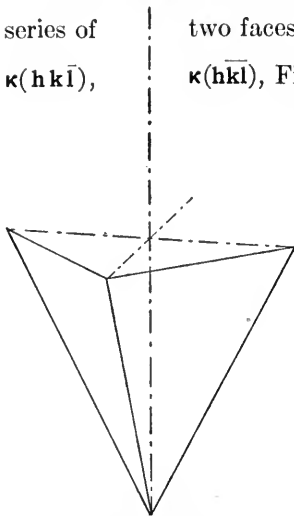

FIG. 253. — The Lower Minus Hemipyramid.

II. Front and rear hemiprisms of two faces each, $f/r \left(\frac{n\dot{a} : \dot{b} : \infty \dot{c}}{2} \right)$, $\kappa(hko)$, $\kappa(h\bar{k}o)$. Fig. 254.

III. Upper and lower clinodomes, $u/1 \left(\frac{\infty \dot{a} : n\dot{b} : m\dot{c}}{2} \right)$, $\kappa(ohl)$, $(oh\bar{l})$, Fig. 255, of two faces each.

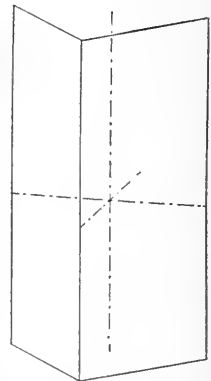

FIG. 254. — Front Hemiprism.

IV. Upper and lower, back and front

hemiorthodome of one face each, $\pm u/1 (n\bar{a} : \infty \bar{b} : m\bar{c})$, (hol), (hol), (hol), (hol), Fig. 256.

V. The ortho and basal pinacoids, from their relation to the axis of symmetry, will each be represented by one face.

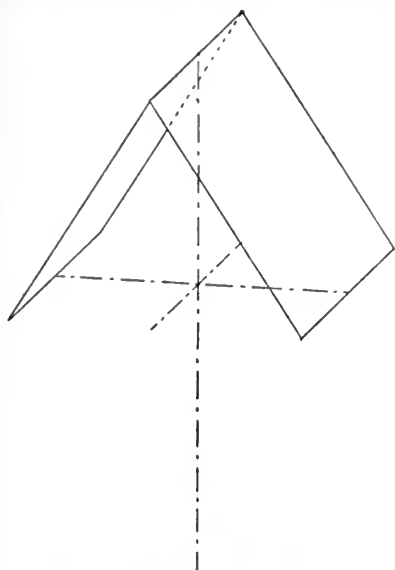

FIG. 255. — The Upper Front Hemimiclinodome.

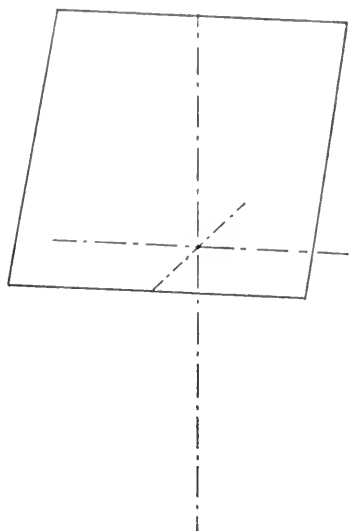

FIG. 256. — The Upper Front Hemiorthodome, (hol).

The clinopinacoid will appear as in type 5 with two faces.

Examples. — A single mineral, clinohedrite, $H_2ZnCaSiO_5$, crystallizes in this type. Fig. 257 is a combination of the plus and minus hemipyramid, (111), plus upper pyramid, ($\bar{7}71$), plus upper pyramid, ($\bar{1}61$), and the back hemiprism, ($\bar{1}10$) as found on this mineral.

Crystalline Elements

In addition to the two axial ratios, in the monoclinic system the angle β is required to fix the characteristics of any crystal form. The angle is measured in the diametral plane, and in the plus octants; its value is therefore always given as less than 90° . It may be

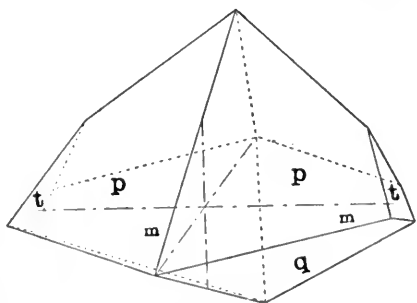

FIG. 257. — Combination of $p(111)$, $q(111)$, $m(\bar{1}10)$, $t(771)$, $z(161)$ on Clinohedrite.

measured directly, being the angle between the base and the orthopinacoid.

Four angles are sufficient to determine the elements: $(100 \wedge 001)$, $(\bar{1}01 \wedge 100)$, $(001 \wedge 011)$ and $(110 \wedge 100)$.

Calculations. — When β is not measured directly, generally $(001 \wedge 110)$ and $(110 \wedge 110)$ can be obtained, Fig. 258. In the right-angled spherical triangle, right-angled at **A**, the two angles **B** $(001 \wedge 110)$ and **C** $= 1/2(110 \wedge 110)$ are known, the two sides **c** and **b** can be calculated. **C** is the angle of the right-angled triangle of which **a** is one leg and **b** the other, also $\beta = 180^\circ - b$.

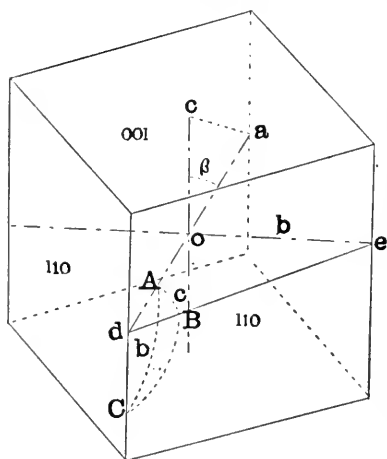

FIG. 258.

triangle $= 112^\circ 13'$ and **C** $= 1/2 (118^\circ 47')$.

$$\cos b = \frac{\cos B}{\sin C} = \frac{\cos (112^\circ 13')}{\sin (59^\circ 24')}$$

$$\text{Log } \cos 112^\circ 13' = 9.577618$$

$$\text{Log } \sin 56^\circ 24' = 9.934783$$

$$\text{Log } \cos b = 9.642745$$

$$b = 116^\circ 3'.$$

$$\beta = 180^\circ - (116^\circ 3') = 63^\circ 57'.$$

The axial ratio. — In the spherical triangle **ABC**, with the side **b** and the angle **C** known, being right angled at **A**, the side **c** is calculated by Napier's rule.

$$\tan c = \frac{\sin b}{\cot C} = \frac{\sin (116^\circ 3')}{\cot (59^\circ 23' 30'')}.$$

$$\text{Log } \sin 116^\circ 3' = 9.953475$$

$$\text{Log } \cot (59^\circ 23' 30'') = 9.772312$$

$$\text{Log } \tan c = 10.181163$$

$$c = 56^\circ 37'.$$

In the triangle doe , right-angled at o and with the side $oe = b = 1$ and the angle ode known:

$$\frac{do}{oe} = \frac{a}{b} = \cot ode = \cot 56^\circ 37' = .658^+ \text{ or } a = .658^+.$$

For the value of c the angle $(001, \bar{1}01) = 50^\circ 16'$.

In the triangle coa , $\beta = 63^\circ 37'$ and $oca = 180^\circ - (50^\circ 16') - (63^\circ 37') = 65^\circ 47'$.

In the triangle aoc , in which the angles and one side $oa = a = .658^+$ are known, $oc = c$ may be calculated.

$oc : oa : \sin oac : \sin oca$, or $c : a :: \sin 59^\circ 16' : \sin 65^\circ 45'$.

$$c = \frac{a \times (\sin 59^\circ 16')}{\sin (65^\circ 45')}$$

Log a =	1.818226
Log sin 59° 16' =	9.885942
	9.704168
Log sin 65° 45' =	9.959852
Log c =	1.744316
	c = .555 ⁺ .

The crystalline constants of orthoclase would be expressed as calculated, $\bar{a} : \bar{b} : \bar{c} = .658^+ : 1 : .555^+ ; \beta = 63^\circ 57'$.

THE TRICLINIC SYSTEM

In the triclinic system all axes are inclined, and none of the five crystalline elements are fixed; the axes are unequal and designated, $\bar{a} : \bar{b} : \bar{c}$, as in the orthorhombic system. Generally the unit plane has been chosen so that the unit on c is smaller than that on b , but this may not be so in all species. Here the diametral planes divide space into octants of four different sizes; of which opposite octants through the center are similar; thus the pyramids of the triclinic system will consist, at the most, of a single pair of parallel faces each subtending octants of the same size. The four possible pyramids are equivalent to the orthorhombic pyramid and in combination inclose space. The axial angles are either greater or less than 90° and are measured in the plus octant, the upper right-hand octant. The angle between \bar{b} and \bar{c} is designated α , that between \bar{a} and \bar{b} , γ , and that between \bar{a} and \bar{c} , β , Fig. 265.

CLASS, HOLOHEDRAL (HOLOSMMETRIC)

TYPE 2, CENTROSYMMETRIC

All forms of this type possess a center of symmetry only and each form is composed of a single pair of parallel faces, Fig. 259.

Forms. — Pyramids.

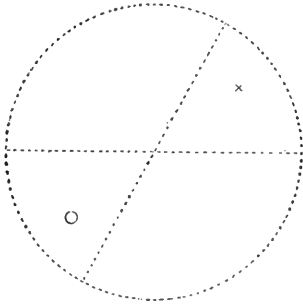

FIG. 259.—Type 2, Centrosymmetric.

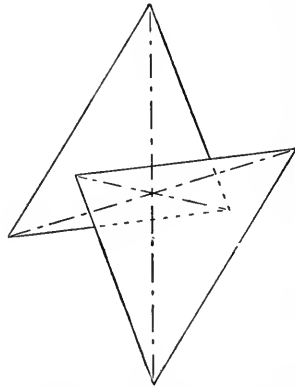

FIG. 260.—Two Faces forming a Triclinc Pyramid.

Unit series of pyramids, $\left\{ \begin{array}{l} \check{a} : b : mc, (\overline{hkl}). \\ \check{a} : b : mc, (\underline{hkl}). \\ \check{a} : b : mc, (\overline{hkl}). \\ \check{a} : b : mc, (\underline{hkl}). \end{array} \right.$

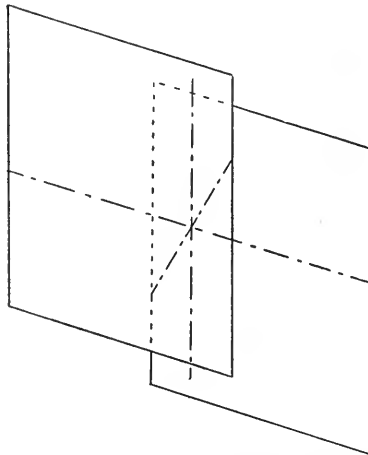

FIG. 261.—Two Faces forming a Triclinc Prism.

Macro series of pyramids, $\left\{ \begin{array}{l} \check{a} : nb : mc, (\overline{hkl}). \\ \check{a} : nb : mc, (\overline{hkl}). \\ \check{a} : nb : mc, (\overline{hkl}). \\ \check{a} : nb : mc, (\overline{hkl}). \end{array} \right.$

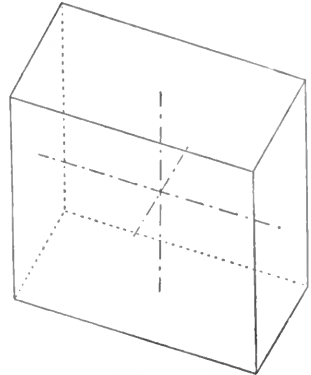
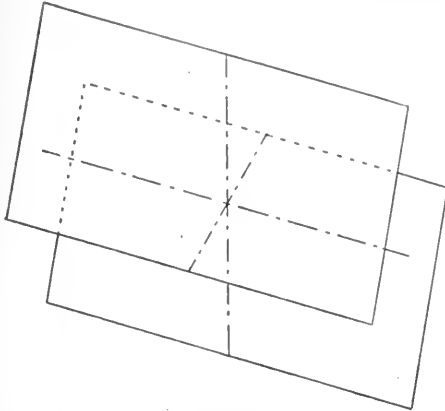

FIG. 262. — The Two Faces which form a Triclinic Dome. FIG. 263. — Combination of the Three Pinacoids.

Brachy series of pyramids, $\left\{ \begin{array}{l} n\check{a} : b : mc, (\overline{hkl}). \\ n\check{a} : b : mc, (\overline{hkl}). \\ n\check{a} : b : mc, (\overline{hkl}). \\ n\check{a} : b : mc, (\overline{hkl}). \end{array} \right.$ Fig. 260.

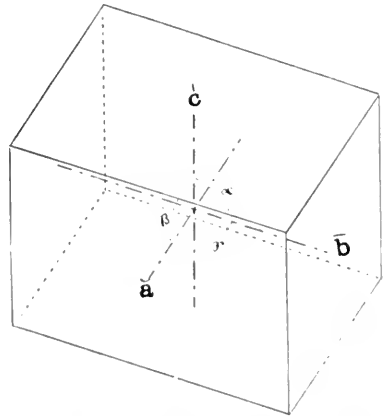
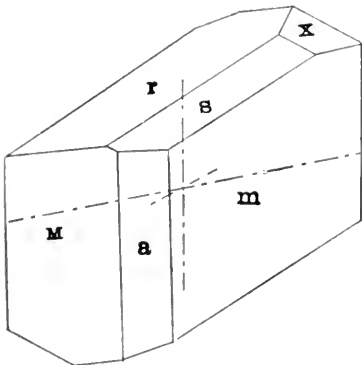

FIG. 264. — Axinite: Combination of $m(110)$, $M(110)$, $a(100)$, $x(111)$, $r(\overline{111})$, $s(201)$. FIG. 265. — Combination of the Three Pinacoids in Rhodonite.

Macro series of prisms, $\left\{ \begin{array}{l} \check{a} : nb : \infty c, (\overline{hko}). \\ \check{a} : nb : \infty c, (\overline{hko}). \end{array} \right.$

Brachy series of prisms, $\left\{ \begin{array}{l} n\bar{a} : b : \infty c, (\overline{hko}). \\ n\bar{a} : b : \infty c, (\overline{hko}). \end{array} \right.$ Fig. 261

Macro series of domes, $\left\{ \begin{array}{l} n\bar{a} : \infty b : mc, (\overline{hol}). \\ n\bar{a} : \infty b : mc, (\overline{hol}). \end{array} \right.$ Fig. 262.

Brachy series of domes, $\left\{ \begin{array}{l} \infty \bar{a} : nb : mc, (\overline{ohl}). \\ \infty \bar{a} : nb : mc, (\overline{ohl}). \end{array} \right.$

Macropinacoid, $\bar{a} : \infty \bar{b} : \infty \bar{c}, (100).$

Brachypinacoid, $\infty \bar{a} : \bar{b} : \infty \bar{c}, (010).$

Basal pinacoid, $\infty \bar{a} : \infty \bar{b} : \bar{c}, (001),$ Fig. 263.

Examples. — The plagioclase feldspars crystallize in this type. Fig. 264 represents a combination of $\underline{(110)}$ $(\overline{110})$ (100) $(\overline{111})$ (201) on a crystal of axinite, in which $\bar{a} : b : c = .492^+ : 1 : .479^+$ and $\alpha = 82^\circ 54'$, $\beta = 91^\circ$, $\gamma = 131^\circ 32'$, $100 \wedge 010 = 48^\circ 21'$.

Fig. 265 is the combination of the three pinacoids in rhodonite, $MnSiO_3$, in which $\alpha = 103^\circ 18'$, $\beta = 108^\circ 44'$, $\gamma = 81^\circ 39'$.

CLASS, TRICLINIC HEMIMORPHIC

TYPE 1, ASYMMETRIC

Symmetry. — Crystals of this type possess no symmetry whatever, and each form of the type is composed of a single face, Fig. 266. Any collection of faces, however irregularly grouped, may belong to this type, provided they conform to the law of rational indices.

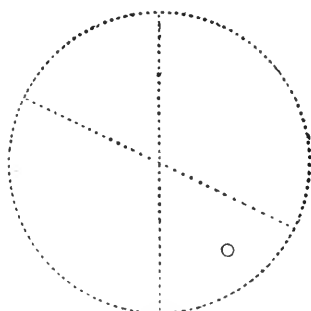

FIG. 266. — Type 1, Asymmetric.

All forms of the type may be considered as being produced

by the selection of one face of the pair forming the corresponding holohedron of type 2.

Forms. — Possible forms will be the same as in type 2, except they will all be hemi

forms consisting of one face each, and designated as the upper right front hemipyramid, or as the lower back hemimacrodome, etc.

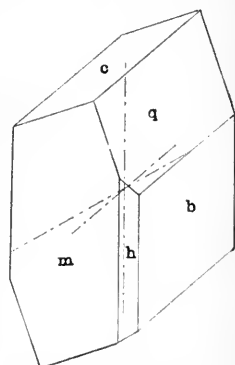

FIG. 267. — Calcium Thio-sulphate: Combinations of $c(001)$, $b(010)$, $m(\overline{110})$, $q(011)$, and $h(\overline{110})$.

Examples. — There are no minerals crystallizing in the type, but several salts, as strontium bitartrate, $\text{Sr}(\text{C}_4\text{H}_4\text{O}_6)_2 \cdot 5 \text{H}_2\text{O}$.

Calcium thiosulphate, $\text{CaS}_2\text{O}_3 \cdot 6 \text{H}_2\text{O}$, Fig. 267, represents the combination of (001) (010) ($\bar{1}\bar{1}0$) (011) ($\bar{1}10$) common on this salt.

The Crystalline Elements of the Triclinic System

In the triclinic system, where no elements are fixed, all five are calculated from measured angles, as none of the axial angles can be measured directly; at least five angles must be measured. The angles generally chosen are the pinacoidal angles, $001 \wedge 100$; $001 \wedge 010$; $100 \wedge 010$, and the angles between the unit form and a pinacoid, as $100 \wedge 110$; $001 \wedge 101$; $001 \wedge 011$. When any five of these angles are measured, the axial ratios and axial angles may be calculated.

CHAPTER VII

RELATION OF INDIVIDUAL CRYSTALS

CRYSTALS as found in nature are rarely simple, or composed of one individual. During the process of formation they must necessarily come in contact with each other; this contact modifies them, not only producing distortions and irregularities in external form, but reëntrant angles are formed. The angles of all simple crystals must be less than 180° , and whenever an angle greater than 180° or a reëntrant angle appears, it is proof that the crystal is of a compound nature or consists of more than one individual. At the time of separation, one crystal may have an influence upon the position or direction of the axes of its neighbor, and this influence may show itself in various ways. Minerals totally different in composition and crystalline structure are sometimes so placed that certain axes and edges are parallel in the two species, as in case



FIG. 268. — Cyanite and Staurolite in Parallel Position from St. Gothard, Switzerland.

of staurolite and cyanite from St. Gothard, Fig. 268; while belonging to different crystal systems, these two species are often so placed that their *c* axes are parallel. Such parallel growths, however, occur the more often between individuals

of the same species, or between species belonging to the same isomorphic group; in such cases large aggregates will have all their crystalline directions parallel as in Fig. 269, sulphur, or as in Fig. 270, microcline from Pike's Peak. In such parallel growths equivalent faces will reflect light or appear bright at the same time.

It often happens that the faces of a large crystal may have a mat-like surface, caused by a layer of small individuals which have been deposited, generally in parallel position, upon the surface of the larger crystal. They either represent a secondary generation, or are the result of changed condition during crystallization, causing a more rapid deposition, Fig. 271.

Drusiness of faces is also produced either by a second generation of the same species, or by secondary minerals

formed by the decomposition of the surface of the mineral upon which the small crystals are placed.

Complete parallelism exists the more often between individuals of the same species, or the species of an isomorphous group. The dividing line between individuals is not always distinct, for as each individual is reduced in size, each may vanish as a line,



FIG. 269. — Parallel Aggregate of Sulphur Crystals. Girgenti, Sicily.



FIG. 270. — Parallel Aggregate of Microcline from Pike's Peak, Colorado.

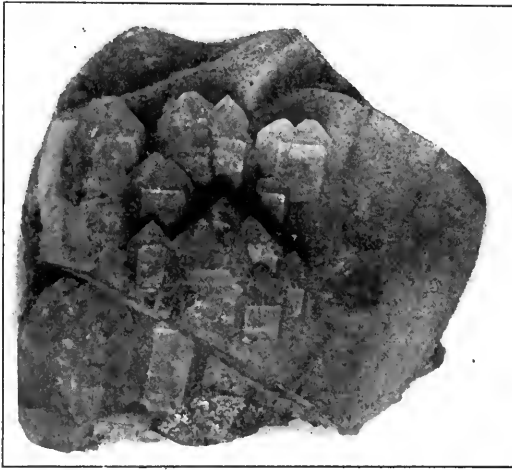

FIG. 271. — Quartz Crystals in Parallel Position on Orthoclase.

and will be represented by a striation running across the crystal face in a fixed direction. Wherever these striations appear on the face of a crystal, they must be considered as the boundary between two individuals. In Fig. 272 *a*, a complex quartz crystal, the individuals are well marked and apparent; but in

Fig. 272 *b*, a quartz crystal with striations running across the prism face parallel to the intersection of the prism and rhombohedron, each striation represents a reëntrant angle between individuals, or the crystal in its growth may be said to oscillate between the

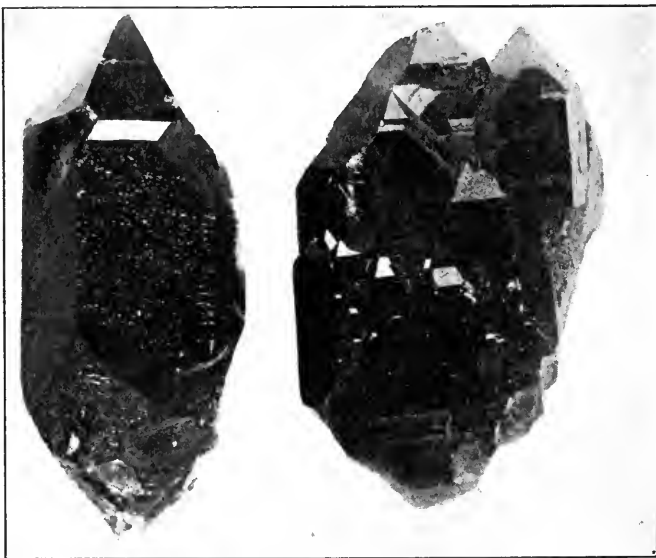

FIG. 272. — Smoky Quartz from Disentis, Switzerland.

prism and the rhombohedron. Striations are very characteristic of certain crystal faces in various mineral species. The cube face

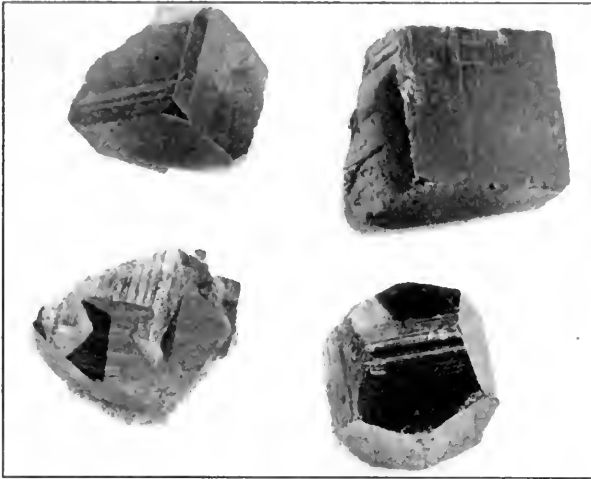

FIG. 273. — Crystals of Pyrite showing Striations on the Cube and Pyritohedron.

in pyrite is striated at right angles to a pair of edges, Fig. 273, representing an oscillatory growth between the cube and the pentagonal dodecahedron or pyritohedron. In tourmaline, Fig. 274, the prism faces are striated lengthwise the crystal, which represents an oscillation between the trigonal and hexagonal prisms.

Twins. — In a large number of unions of crystals, all crystallographic equivalent directions are not parallel, as in parallel growths; some may be parallel and others at an angle, as if rotated around an axis 180° , or as if reflected across a plane.

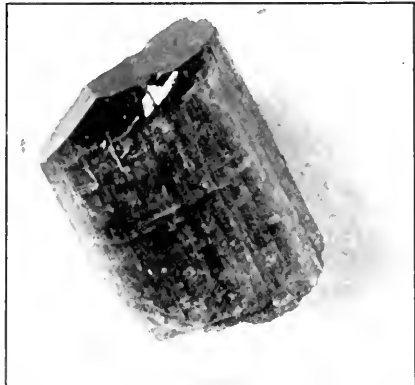

FIG. 274. — Tourmaline from Pala, California, showing Longitudinal Striations on the Prism.

Fig. 275 is a diagrammatical representation of 6 molecules. In **a**, **b**, and **c** the equivalent directions are all parallel, as in a simple crystal, but **x**, **y**, and **z** are reversed, as if reflected over the plane

mn. Again, **a**, **b**, and **c**, when revolved around **mn** as an axis 180° , will become congruent with **x**, **y**, and **z**. The molecules **a**, **b**, **c** are said to occupy a twinning position in regard to **x**, **y**, **z**, and the two individuals are said to be twins. The axis of revolution

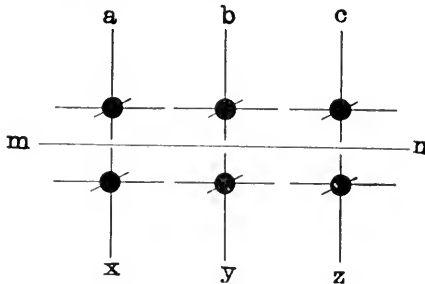

FIG. 275.

is the **twinning axis**, and a plane at right angles to the twinning axis is the **twinning plane**. The plane separating the two individuals is the **composition** or **contact plane**; this with rare exceptions is parallel to a possible crystal face.

The twinning axis is either parallel to a possible crystal edge or perpendicular to a possible face. It can never be an axis of even symmetry, as by a revolution of 180° around such an axis the two individuals would be congruent and form a simple crystal. Fig. 276 represents a simple crystal of gypsum; Fig. 277 is a twin

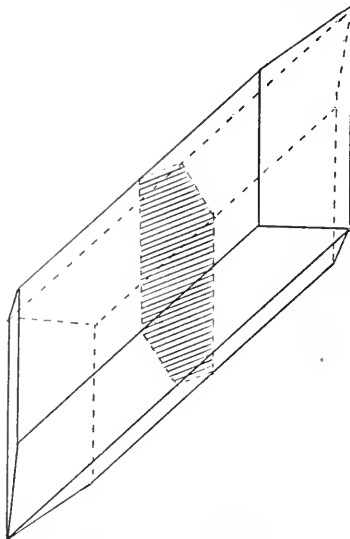

FIG. 276. — Gypsum Crystal showing the Position of the Twinning Plane.

crystal of gypsum in which the twinning axis is parallel to the vertical axis **c**. Fig. 278 is a twinned crystal of gypsum in which it may be seen that one individual has been revolved around the

twinning axis c 180° , and also that the twinning axis is parallel to the edge in the prism zone. The shaded plane is the contact plane and is parallel to the orthopinacoid. The trace of the twinning plane in the crystal is usually marked by a reëntrant angle, as xyz , or, where this is reduced to a minimum, by striations on the crystal face, as yy' , Fig. 278.

A reëntrant angle is not always present to distinguish the crystal as a twin, and often when absent, as is shown in the epidote crystals from Prince of Wales Island, Alaska, Fig. 280, where the twinning axis is perpendicular to the orthopinacoid and the composition and twinning plane is the orthopinacoid, and which after a revolution of 180° , leaves on these crystals no indication of the twinning.



FIG. 277. — Gypsum Twins from near Paris, France.

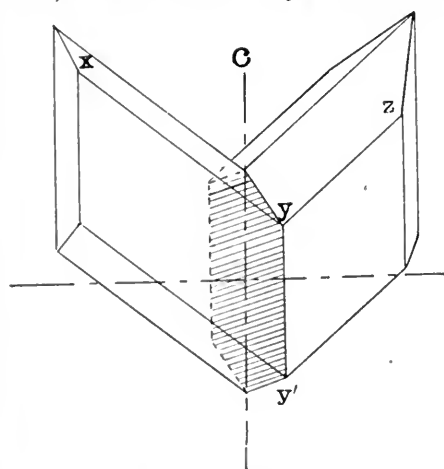

FIG. 278. — Gypsum Twins.

Striations on the clinopinacoid due to parallel growth are indicated by the parallel lines, and the effect of twinning on these striations is shown. The striations meet the twinning plane, yy' , from each individual at the same inclination, and the trace of the twinning plane on the crystal face bisects the angle between them.

The complexity of some apparently simple crystals is often only revealed by the microscope and polarized light, as in the twinning bands of the plagioclase feldspars, Fig. 281. In enantiomorphic types,

where there are right- and left-handed forms, it is not possible to revolve one individual around an axis into a congruent position,

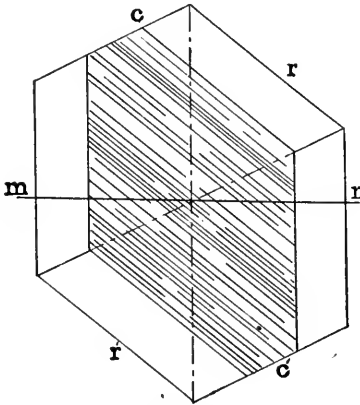

FIG. 279.—Simple Crystal of Epidote.

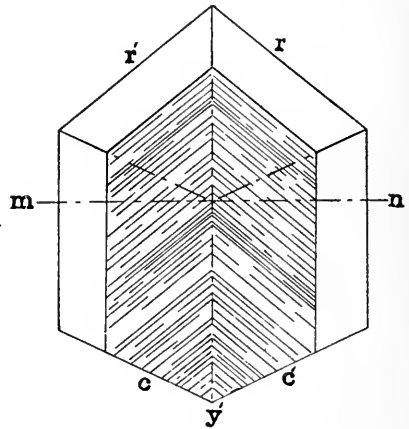

FIG. 280.—Twinned Epidote from Prince of Wales Island, Alaska.

and a twinning axis is therefore not always possible; but such crystals are twinned by reflection, as some twins of quartz. Twins formed by the union of plus and minus, upper and lower, or right

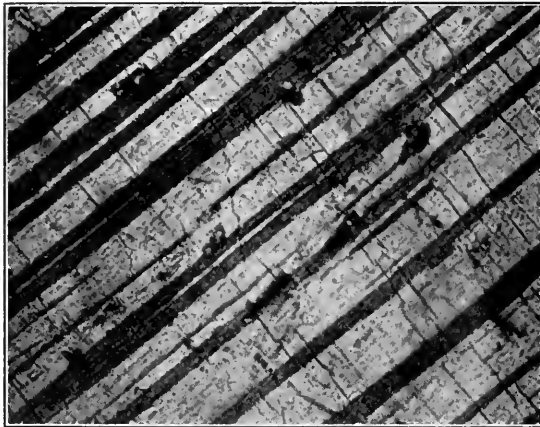

FIG. 281.—Twinning Lamellæ of Plagioclase, between Crossed Nicols.
Much enlarged.

and left forms are **supplementary twins**; and when as contact twins, and equally developed, the individuals will possess a pseudo-

symmetry or a symmetry of a higher type, as the upper and lower forms of a polar type when joined along the plane of the base will possess the symmetry of an equatorial type.

The plus and minus forms may penetrate each other and be distinguished as complex individuals by the reëntrant angles. Fig. 282 is a drawing of the supplementary twins of pyrite, formed by the plus and minus pyritohedrons;

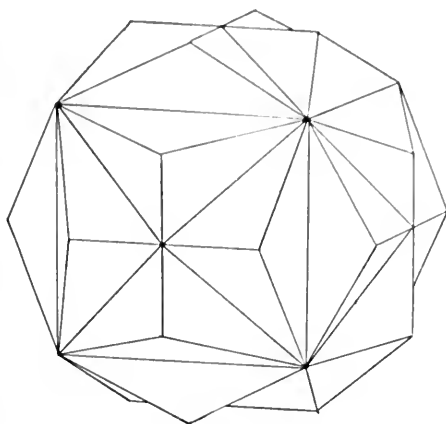

FIG. 282. — Supplementary Twins of Pyrite.

while Fig. 283 is a photograph of these twins from Prussia. In interpenetrating twins there is no marked plane of contact between individuals, but a very irregular and ill-defined area separates the two individuals internally.



FIG. 283. — Supplementary Twins of Pyrite.

In the growth of crystals the twinning position may have been assumed at the very outset, in the nucleus of crystallization, and the complex nature existed at the beginning of crystallization; or again the

individuals may have developed as simple crystals, when through a changed condition molecules have separated in a twinned position and the axis of the simple crystal is abruptly changed. Where there is but one angle in the axis of an elongated crystal they are often termed **geniculate** twins, as the geniculate twins of rutile, Fig. 284.

This bending or angle in the axis of the crystal may be repeated either in the same direction or in the op-

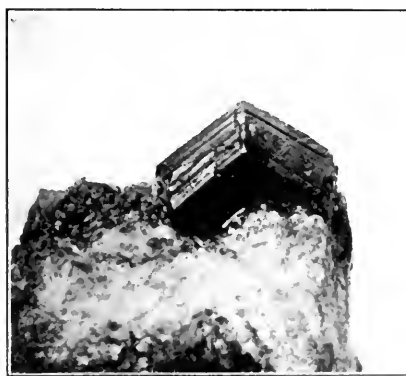

FIG. 284. — Geniculate Twins of Rutile from Lancaster County, Pennsylvania.

posite direction. When repeated in the same direction a number of times, the complex individual is circular and is termed **cyclic**



FIG. 285. — Cyclic Twins of Marcasite from Folkstone, England.

twins, as in marcasite, Fig. 285; or the twinning may be repeated first in one direction and then in the other, with a zigzag effect, as in rutile, Fig. 286.

When the twinning is repeated many times at very short intervals, each individual of the complex structure will be confined to a very thin sheet passing through the aggregate, parallel to the composition plane, and indicated on the crystal externally by a re-

entrant angle as illustrated in Fig. 287, a twin crystal of albite in which the clinopinacoid is the composition plane and the twinning axis is perpendicular to this face. Fig. 288 is a crystal of albite

composed of several individuals twinned after this same law; each individual is indicated by the reentrant angle passing around the crystal parallel to the twinning plane. Each individual may be reduced to extreme thinness, when only a striation on the crystal face will remain to mark the plane of contact separating individuals, the whole complex structure building up an apparently simple crystal. When often repeated in this manner, the twinning is termed **polysynthetic**.



FIG. 286. — Zigzag twins of Rutile.

The striations produced by polysynthetic twinning are quite different from those caused by parallel growths; the former pass through the body of the crystal and are caused by the arrangement of the molecules and will therefore appear, not only on crystal faces, but also on all cleavage faces intersecting the twinning planes,

as in the plagioclases. The latter are confined to the crystal face and are not caused by a change in the molecular arrangement, and will therefore not appear on cleavage faces or be indicated below the surface.

Twinning in the isometric system. — In isometric minerals the spinel law is the most common. In this method of twinning the

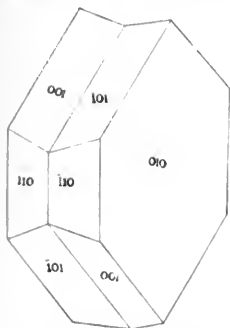

FIG. 287. — Twins of Albite.

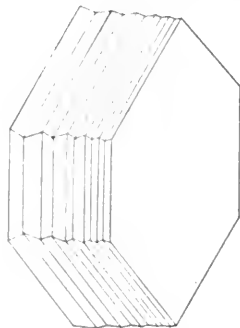

FIG. 288.

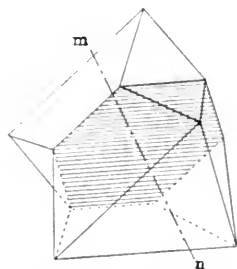

FIG. 289. — Spinel Twins.

trigonal axis, which is common to the five types of the system, is the twinning axis, and the face of the octahedron 111 or the plane parallel to it is the composition plane. For all minerals crystallizing in the isometric system this is a possible form of twinning. Fig. 289 is a drawing in which mn is the twinning axis, and Fig. 290 is a photograph of spinel twins from Franklin, New Jersey.

Penetration twins with the same axis as the twinning axis occur in galena and fluorite, Fig. 291, twins of fluorite.

The second law is where the twinning axis is perpendicular to the face of the rhombic dodecahedron face, 110, and is a possible twinning law in those types only where this axis is



FIG. 290. — Spinel Twins from Franklin, New Jersey.



FIG. 291.—Penetration Twins of Fluorite.

101, and the composition plane cc is parallel to 101. Fig. 293 is a photograph of a natural twin from Zinnwald, Bohemia. In the ditetragonal ^{alternating} ~~parallel~~ type, the normal to the sphenoids 111 is the twinning axis, with the sphenoidal face the composition face; when developed as contact twins, they are similar to the spinel twins of the isometric system.



FIG. 293.—Cassiterite Twins from Zinnwald, Bohemia.

not an axis of symmetry, as the tesseral central and tesseral polar types. The supplementary twins of pyrite are of this class.

Twinning in the tetragonal system.—The general law in this system is where the twinning axis is perpendicular to a pyramid face and is a possible mode of twinning in all seven types of the system. Fig. 292 is a drawing of twins of cassiterite, in which the twinning axis is perpendicular to the pyramid face

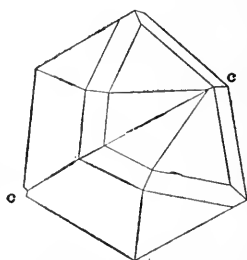

FIG. 292.—Twins of Cassiterite.

In the tetragonal polar types a third twinning law is possible, as in these types the lateral axes are not axes of symmetry and are therefore possible twinning axes. These are supplementary twins, and when there is no reëntrant angle at the equatorial plane there is nothing to indicate the twinned nature of the crystal, and the symmetry is apparently that of an equatorial type. Most crystals of wulfenite are of this character.

Twinning in the hexagonal system.—Twins in the hexagonal division are rare. A possible law in all the types of the system is where the twinning

axis is perpendicular to a pyramid face and the pyramid face is the composition plane. This law is a very common one in the trigonal types; and is the same as where the twinning axis is perpendicular to a scalenohedral or rhombohedral face. In calcite the common form of twinning is where the twinning axis is normal to the rhombohedron e ($01\bar{1}2$), Fig. 294.

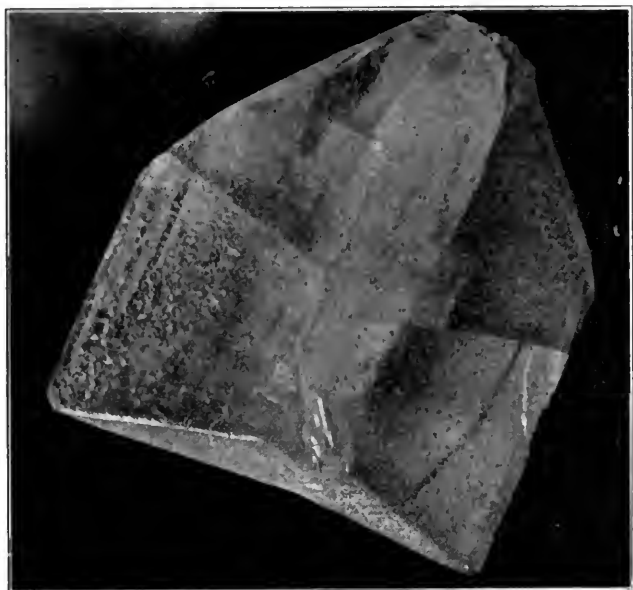

FIG. 294. — Calcite Twins in which e ($01\bar{1}2$) is the Composition Face. Guanajuato, Mexico.

In types of alternating symmetry and trigonal types the vertical axis is a trigonal axis, and is therefore a possible twinning axis with the base as the composition plane; Fig. 295 is such a twin of calcite. In the polar types supplementary twinning, as in the tetragonal system, is a possible law. There are very few minerals of these types; the most common is tourmaline, in which there are no twins; and in nephelite the polar symmetry is shown by the etch figures only, and all crystals must be considered as examples of supplementary twinning.

In the holoaxial types, of which quartz is an example, twinning by reflection is the rule, as in the Brazilian twins, where the plane of reflection is parallel to the prism face ($11\bar{2}0$), Fig. 296, and x is a reflection of x' .



FIG. 295. — Twins of Calcite in which the Twinning Axis ϵ and the Composition Plane is the Base. Guanajuato, Mexico.

Twinning in the orthorhombic system. — There are three classes of twins possible in all three types of the system: —

I. Where the twinning axis is normal to a pyramid face. This is in fact a possible law in all 32 types of crystals, considering the octahedron and its resulting hemihedral forms as pyramids. In Fig. 297 *a*, twins of staurolite, in which the twinning axis is normal to the pyramid (232).

II. Where the twinning axis is normal to a prism face. Fig. 298 is a diagram of aragonite, in which the twinning axis is normal to the prism 110, often repeated, and as the prism angle is nearly 120° , the twinned crystals have a pseudo-hexagonal symmetry, Fig. 299.

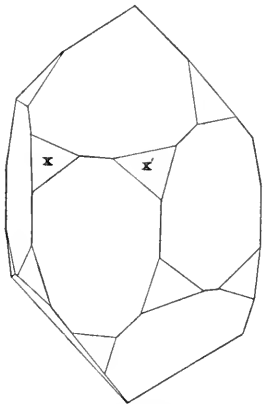

FIG. 296. — Brazilian Twins of Quartz.

III. Where the twinning axis is normal to a dome, as is well illustrated by the cross-shaped twins of staurolite, Fig. 297 *b*, in which the twinning axis is normal to the dome (032).

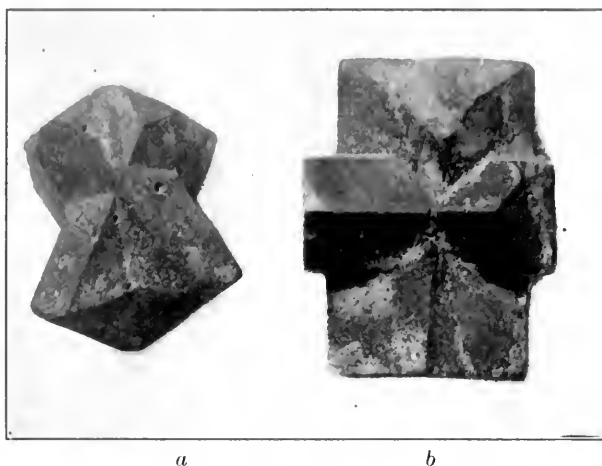

FIG. 297. — Staurolite Twins from Georgia.

In the didigonal equatorial type all faces may be twinning faces, except the three pinacoids, the normals to which are the axes of

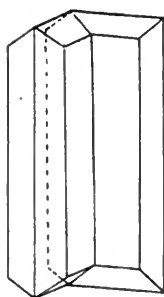

FIG. 298. — Twins of Aragonite, Twinning Plane 110.



FIG. 299. — Triplets of Aragonite from Bastanes, France.

symmetry. In the sphenoidal and digonal holoaxial types, these normals are still digonal axes of symmetry, and only the above three types are possible. In the digonal polar type supplementary

twins are possible, as here the lateral axes are not digonal axes of symmetry and may be twinning axes with the base as the composition plane. These supplementary twins are well illustrated by calamine.

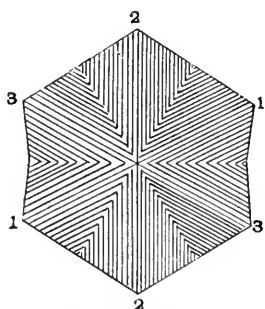

FIG. 299 a. — Diagram of the Basal Plane of Aragonite Triplets, showing the Relation of the Individuals.

Twinning in the monoclinic system. — The only direction not possible as an axis of twinning is the orthoaxis, and twins are very common in the system. They may be divided into the three types as in the orthorhombic system, with the addition that the two pinacoids may also be twinning planes. In gypsum and augite the twinning plane and composition plane is the orthopinacoid, and the twinning axis is the normal to it. In the Carlsbad twins of orthoclase the twinning

axis is the vertical axis, while the composition plane is the clinopinacoid, parallel to it, Fig. 300.

Twinning in the triclinic system. — As there is only a center of symmetry, any plane is possible as a twinning plane and twins are

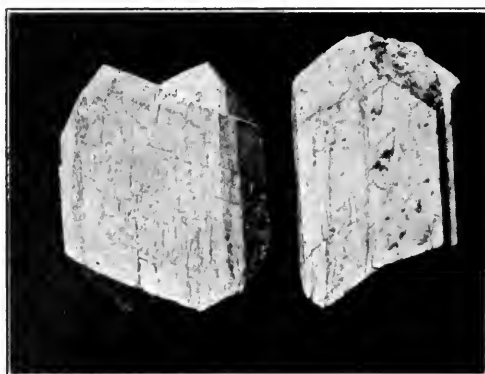

FIG. 300. — Carlsbad Twins of Orthoclase. Brice, New Mexico.

numerous and complicated, often repeated polysynthetically as in the plagioclase feldspars.

CHAPTER VIII

ON THE MEASUREMENT OF CRYSTALS AND THE USE OF THE GONIOMETER

It is often necessary to measure the angles between two crystal faces in order to identify the forms present on the crystal, particularly when the specimen is much distorted. This may be true even with such well-developed and easily recognized forms as the prism and rhombohedron on quartz. The forms present in complicated combinations must always be proven by the measurement of the angles between the faces. The measurement of the angles will also help in the identification of the mineral species; and in chemical compounds their variation from the theoretical value may afford a means of estimating the purity of the compound, as chemically pure substances possess a constant and characteristic angle between crystal forms, though in isomorphous groups these angles are very nearly equal; yet when pure each member of the group will possess an angle distinctly its own.

The goniometer and the principles of the reflecting goniometer have been described in Chapter I.

For the identification of crystal forms when the crystals are not too small, the Penfield card contact goniometer, model B, Fig. 11, is a very convenient and sufficiently accurate little instrument, and it has the advantage of cheapness, so that each student may be provided with or possess one. It answers also as a protractor and scale in the drawing of crystals.

In using the instrument, the card with the scale is held at right angles to the edge and one of the crystal faces, the angle between which and the adjacent face it is wished to measure. The arm of the instrument is then rotated until it is in contact with the second crystal face; the crystal with the goniometer in place is now held up to the light, with the line of vision parallel to the edge between the two faces; the arm and card are carefully adjusted to fit the two faces and the angle between them, so that no light is seen between the instrument and the crystal faces. The instrument must

be held perpendicular to the crystal faces, as the true angle is obtained only in this position; after satisfactory adjustment the angle is read from the card. This model also has the advantage of giving both the actual angle between the faces and the supplement to it or that between the poles, which is the angle usually recorded in the description of crystals.

With smooth faces and as large as a centimeter across, the angles between them may be measured with the contact goniometer to within one degree, an accuracy sufficient for the identification of forms and species. Fig. 301 is a more expensive instrument, in which the two arms are detached from the scale and one moves along the other, which enables one to measure crystals separated

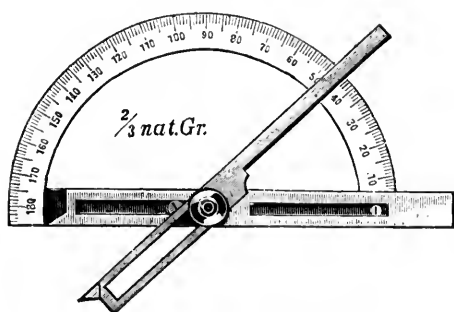

FIG. 301.—Contact Goniometer.

by reëntrant angle. To gain experience in the use of the instrument it is well for the student to measure the angles and identify the faces on a distorted Herkimer County quartz crystal of about 1.5 cm. in diameter.

When more accurate work is required, as in the calculations of the crystalline constants or characters of any mineral and in the determination of the indices of the faces as well as the identification of new forms, the reflecting goniometer is used.

There are several varieties of this instrument. One, the single-circle goniometer, in which the angle is measured between the poles of the two faces in question. Another, the two-circle goniometer, by which the pole of any face is located, in reference to some chosen face as the base. The face may be said to be located by its latitude being measured on one circle and its longitude being measured on the second circle at 90° to the first, just as a point on the earth's surface is fixed. There is also a more complicated instrument in which three graduated circles are used. Of these instruments only the single-circle goniometer will be described.

The card contact goniometer may be easily converted into a single-circle reflecting goniometer, for use in measuring crystals too small to yield results sufficiently accurate by the contact method of measurement. If a bridge be cemented on the arm over the eye-

let or axis of the instrument, the crystal to be measured may be fastened on this with wax and measured. The small crystal is then mounted with the edge to be measured perpendicular to the card, and the edge should coincide as nearly as possible with the axis of the arm; then with the edge of the card placed on the edge of the table and with the eye at a distance of a foot and a half, the arm is revolved until one of the faces reflects the light, when a reading is taken. The instrument is replaced with the light, card, and eye in the same relative positions, which may be assured by getting the reflection on the same face without moving the arm; the arm is now revolved until the second face reflects the light, when another reading is taken. The difference between these two readings will be the angle between the poles of the two faces reflecting the light. Results obtained by this method are more accurate than those obtained by the contact method. It may be unnecessary to state that the accuracy of the measurements is increased with the distance of the light and the eye from the crystal.

The principles of the reflecting goniometer have been sufficiently illustrated by the measurement of a crystal with the card con-

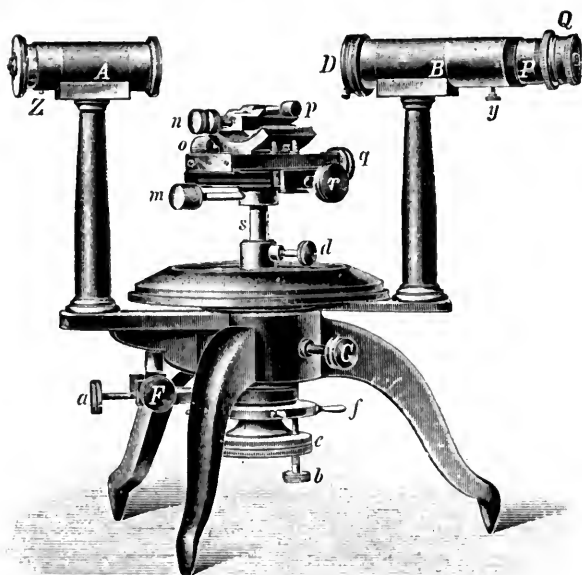

FIG. 302. — The Fuess Single-Circle Reflecting Goniometer. One Quarter Natural Size.

tact goniometer as just described above. The accuracy of the results obtained will depend upon the size of the source of light used; on the exact parallelism of the intersecting edge between the two faces with the axis of the instrument; and upon the plane of reflection, the plane in which the angle is measured being at exactly 90° to the edge of the crystal and the axis of the instrument.

The instrument is constructed with all of these conditions in view and is provided with devices allowing of adjustments to these ends. Fig. 302 is the usual form of the Fuess single-circle goniometer one-fourth natural size. The collimator **Z** is supported by the post **A**, which is rigidly fixed to the frame of the instrument. The collimator is provided with a lens at the inner end, and at the focus of this lens at the outer end the slit admitting light is placed. The shape and size of this opening may be adjusted in the more expensive instruments to suit the work at hand. The usual form is that illustrated in Fig. 303, and known as the Websky signal slit, hourglass in shape, with its vertical plane of symmetry vv' parallel to the axis of the instrument and fixed in this position.

The telescope **B** is supported by a similar post but attached to the disk or circle upon which the vernier of the scale is marked, and can be revolved about the axis of the instrument, and rigidly fixed in any required position by the set screw **C**. The telescope is fitted with an eyepiece **Q**, which is provided with cross hairs at right angles, one of which is fixed parallel to the axis of the instrument, the other will be at 90° to the axis. The eyepiece is adjusted to

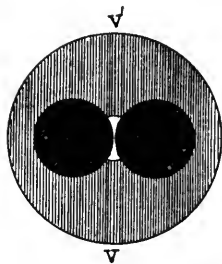

FIG. 303.—The Websky Signal.

this position by the collar which clamps on the eyepiece and which fits in a notch in the drawtube of the telescope, thus always assuring the correct position of the vertical hair when the eyepiece is withdrawn and returned to its position.

The two cross hairs should divide the Websky signal orthorhombically when the telescope is set directly opposite the collimator, as illustrated in Fig. 304. The telescope eyepiece is adjusted to parallel rays; and when it is wished to view the crystal being measured, the lens **D** is placed before the tube and focuses the rays on the axis of the instrument. This lens may be revolved out of the field, when the signal will appear if a face is in position.

The circular disk shown under **d** is the graduated circle, which is

divided to half degrees and with the vernier may be read to minutes. This circle is revolved by the pilot wheel *f*, which in turn may be clamped to the axis of the instrument by the set-screw *b*. This circle may be accurately turned to any particular point by first revolving it with the pilot wheel and then setting the screw *a* and using the fine adjustment, or tangent screw *F*.

The crystal to be measured is cemented with wax to a carrier which fits in a socket in the table of the instrument and is held in place by the screw *p*; the screw *d* allows this table to be elevated or lowered until the edge to be measured may be seen in the telescope.

In order to adjust the crystal there are four movements necessary, each of which is controlled by a separate screw: two, *r* and *q*, are screws at right angles to each other and allow the carrier to be pushed back and forward; and the two screws *n* and *o* are connected with sections of cylinders, the axes of which are at 90° ; these allow the crystal to be tilted in planes at 90° . By these four screws the edge to be measured may be quickly brought to coincide with the axis of the goniometer and therefore at right angles to the plane of reflection, and the edge after adjustment will also be in focus when the lens *D* is before the telescope.

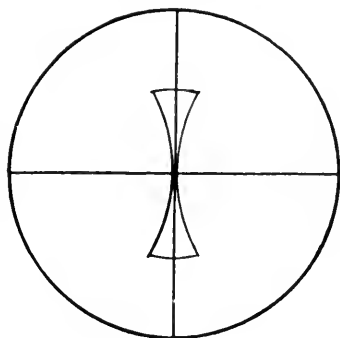

FIG. 304.

Measurement of a crystal. — Let the crystal selected for measurement be one of topaz from Thomas Mountains, Utah, as these crystals are combinations of forms of several zones, and usually they possess bright smooth faces. The crystal is first cleansed with alcohol and ether and then not touched with the fingers to dull the faces and spoil their reflecting qualities. The various zones present are noted and rough sketches or sections at right angles to each zone made; each face in the zone sketched is represented by a letter on the drawing and the letter placed opposite the reading taken of the face when the angles are measured; this enables each reading of the goniometer to be referred to the right face.

The crystal is now mounted on a carrier with the edges of the zone to be first measured perpendicular to its surface; the carrier

is now clamped in the instrument. Let the crystal be first mounted on the flat basal cleavage and the prism zone the first zone to be measured, the edges of which are all at right angles to the basal cleavage. The crystal is elevated or depressed by means of the screw **d** until it is in the plane of reflection. With the screw **b** set and the screw **a** loose, the telescope is revolved until its axis is at about 110° with the collimator and there set with the screw **C**. The lens **D** is placed before the telescope and the goniometer light before the Websky slit in the collimator; the crystal is now adjusted. With the right hand on the screw **q** and the axis of this screw at 90° to the telescope, and the left hand on the screw **n**, the crystal is pushed back and forth with the right hand until an edge is seen in the telescope, when with the left hand this edge is tilted until it is parallel to the vertical hair, and it is placed directly on the hair with the right hand. The crystal is now revolved with the pilot wheel **f** 90° to the right and the right hand is placed on the screw **r** and the left on the screw **o**; the same edge is adjusted to coincide with the vertical hair as before. After these adjustments have been carried out accurately, the crystal when revolved will turn on the edge as an axis. This edge will now lie in the axis of the instrument and will therefore be at 90° to the plane of reflection and in position to measure.

The crystal is now rotated until one of the adjacent faces to the edge adjusted is seen in the telescope to reflect the light from the collimator, the lens **D** is lifted and the signal will appear. The signal is revolved by means of the pilot wheel **f** to the vertical hair; with the screw **a** set, the hair is made to exactly divide it, by means of the tangent screw **f**; if the adjustments have been accurate, the two hairs will divide the signal as illustrated in Fig. 304. If they do not, they are made to do so by slightly readjusting the crystal. The crystal is now revolved until the adjacent face reflects the signal; and as this is in the same zone, it will need but little adjustment to bring the signal into symmetrical position. Before taking any readings both signals should come into position with a simple revolution of the crystal and without any adjustment of the screws connected with the crystal; when this is the case, the crystal is in position to measure.

It is always best to take the first reading, in the measurement of a zone, near the zero on the circle, but on the 359° side and to revolve the crystal so as to decrease the number of degrees in each succeeding reading; they will then all stand in the column, so

that any one below may be subtracted directly from any one above it.

In the prism zone on the crystals of topaz from Thomas Mountains there are usually two prisms and the brachypinacoid, yielding ten readings to complete the 360°. Fig. 305 is a plan of this zone with the faces lettered according to the usual practice. Let the first reading be taken of the face *m*. With the edge *m* \wedge *l* adjusted the signal from *m* is brought to the vertical hair as described, then a reading of the vernier is taken with a lens, and the number of degrees and minutes recorded in the notes opposite the letter standing for the face on the sketch. All faces of the zone are measured in the same manner, and as their intersecting edges are parallel, but little adjustment should be necessary as each edge in order is brought to the vertical hair. It is usual in accurate work to make three readings of the same angle, using different parts of the graduated circle each time, to avoid being influenced by the same number; and the average of these three results is taken as being more nearly correct than any one. It is also well to note opposite each reading the character of the signal reflected by the face, as to whether it is well defined and bright, or irregular, dull, diffused, or complex from striations, as well-defined and bright signals will yield results nearer the truth than any poor signal will and all readings from bright sharp signals are to be given more weight in results. The following are the results of the readings in the prism zone of such a crystal of topaz:

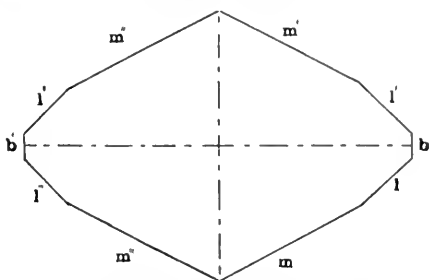

FIG. 305.—Section of a Topaz Crystal 90° to the Prism Zone.

READINGS		ANGLES	
<i>m</i>	= 358° 42'	<i>b</i> \wedge <i>m</i>	= 62° 9' ; <i>b</i> \wedge <i>l</i> = 43° 22'
<i>l</i>	= 339° 55'	<i>b</i> \wedge <i>m'</i>	= 62° 9' ; <i>b</i> \wedge <i>l'</i> = 43° 29'
<i>b</i>	= 296° 33'	<i>l</i> \wedge <i>l'</i>	= 86° 51'
<i>l'</i>	= 253° 04'		
<i>m'</i>	= 234° 24'	<i>m</i> \wedge <i>m'</i>	= 124° 18'
<i>m''</i>	= 178° 42'	<i>m'</i> \wedge <i>m''</i>	= 55° 42'
<i>l''</i>	= 159° 52'	<i>l'</i> \wedge <i>l''</i>	= 93° 12'

READINGS	ANGLES
$b' = 116^{\circ} 3'$	$b' \wedge m'' = 62^{\circ} 8'; b' \wedge l'' = 43^{\circ} 18'$
$l''' = 73^{\circ} 05'$	$b' \wedge m''' = 62^{\circ} 8'; b' \wedge l''' = 43^{\circ} 29'$
$m''' = 54^{\circ} 26'$	$l''' \wedge l'' = 86^{\circ} 47'$
$m' = 358^{\circ} 43'$	$m''' \wedge m'' = 124^{\circ} 16'$
	$m''' \wedge m = 55^{\circ} 43'$

The signals yielded by the prism 1 are complex from striations and therefore the angles vary considerably.

From the above measurements the angles for the two prisms are: for m , $m'' \wedge m''' + m''' \wedge m' = 111^{\circ} 25' \div 2 = 55^{\circ} 42.5'$; and for l , $l \wedge l' + l'' \wedge l''' = 173^{\circ} 38' \div 2 = 86^{\circ} 49'$. As the prism m has been selected as the unit prism, it will intersect the macro- and brachy-axes at unit lengths, or these lengths will be in the ratio of the unit on the \bar{b} axis to the unit on the \check{a} axis. In order to determine this ratio with sufficient accuracy for use in the drawing of the crystal, lay off, Fig. 306, ob , equal to unity on the macroaxis, say 5 cm., and draw oa , the brachyaxis, at 90° , then draw om , making the angle $aom = 1/2 (55^{\circ} 42.5') = 27^{\circ} 51'$; from b draw ba

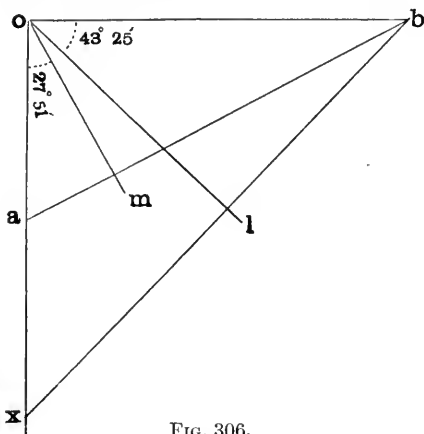

FIG. 306.

perpendicular to om and where it cuts the a axis will be unit length from o , as $oa =$ unity on \check{a} , which by measurement = $.52^+$, or $oa = 52/100$ of ob .

Having the units on the axes \check{a} and \bar{b} the parameters and indices of l may now be determined; in the same way from o draw ol , making the angle $bol = 1/2 (86^{\circ} 49') = 43^{\circ} 25'$, and from b draw bl at right angles to ol , and where it cuts the \check{a} axis at

x is its intercept when it cuts the \bar{b} axis at unit length, ox is by measurement just twice oa ; the parameters of l will be, therefore, $2\check{a} : \bar{b} : \infty c$ and its indices (120) . $m = \check{a} : b : \infty \check{c}$, (110) .

The faces b, b' , since their normals bisect the angles of these two prisms, is a pinacoid, and its indices and parameters may be written at once as $\infty \check{a} : b : \infty \check{c}$, (010) , the brachypinacoid.

Measurement of the pyramid zone. — The crystal is now removed from the holder and remounted with one of the edges of the pyramid zone perpendicular to the flat surface of the holder. It is then clamped in the goniometer and an edge adjusted as before; the edge first selected for measurement should be that between the unit prism and the first pyramid, as all the pyramids are in the zone with the unit prism. The first reading is taken from m and continued around the zone, taking the faces in order through the 180° until m'' is reached. The following are the results of measurements in this pyramid zone:

FACES	READINGS	ANGLES
m	$= 185^\circ 22'$	$c \wedge m = 90^\circ 01'$
o	$= 159^\circ 15'$	$c \wedge o = 63^\circ 54'$
u	$= 140^\circ 56'$	$c \wedge u = 45^\circ 35'$
i	$= 129^\circ 36'$	$c \wedge i = 34^\circ 15'$
c	$= 95^\circ 21'$	
i''	$= 61^\circ 07'$	$c \wedge i'' = 34^\circ 14'$
u''	$= 49^\circ 44'$	$c \wedge u'' = 45^\circ 37'$
o''	$= 31^\circ 26'$	$c \wedge o'' = 63^\circ 55'$
m''	$= 5^\circ 23'$	$c \wedge m'' = 89^\circ 58'$

It is seen that the face c is 90° from the prism and is therefore the base; its parameters and indices are $\infty a : \infty b : c$, (001).

The second pyramid zone, including the prism faces m'' , m' , may be measured and averaged with the readings of the first. From the above results the indices of the pyramids present are determined graphically as follows. Some one of the pyramids must be chosen as the unit pyramid or the fundamental form in order to arrive at the unit on the axis c ; for this pyramid u has been chosen. To determine the length of c , draw, Fig. 307, oc the vertical axis and om at right angles to it, making $om = om$ of Fig. 306, as om is the trace of the zonal plane, at right angles to the prism face.

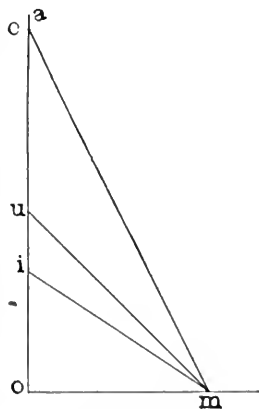

FIG. 307.

It is the plane in which all the poles of the pyramids lie and is therefore the plane in which all the angles have been measured; then in Fig. 307, from m draw mi , making

the angle $\text{omi} = c \wedge i$ and $\text{omu} = c \wedge u$ and $\text{omc} = c \wedge o$; where these lines, mi , mu , mc , intersect the axis \bar{c} will be their intercepts on \bar{c} when it is unity on \bar{b} . As u is the unit pyramid, ou will be unity on \bar{c} , and by measurement and comparison to the unit on $\bar{b} = .47^+$. The axial ratios as determined are, $\bar{a} : \bar{b} : \bar{c} = .52^+ : 1 : .47^+$; as calculated they are, $\bar{a} : \bar{b} : \bar{c} = .5285 : 1 : .4769$.

In comparison, the intercept of the pyramid o on the axis \bar{c} , oc , is just twice ou , and the intercept of i , oi , is $2/3$ of ou . The parameters and indices of the three pyramids may now be written as follows:

$$\begin{aligned} u &= \bar{a} : \bar{b} : \bar{c}, (111). \\ o &= \bar{a} : \bar{b} : 2 \bar{c}, (221). \\ i &= \bar{a} : \bar{b} : 2/3 \bar{c}, (223). \end{aligned}$$

There are usually two brachydomes present, and these may be measured next by remounting the crystal with an edge of this zone perpendicular to the holder and adjusting an edge in the goniometer as before. Starting with the first reading from one of the faces further from the base the results obtained are as follows:

y

f

c

o

FACE	READINGS	ANGLES
y	= 179° 20'	$c \wedge y = 62^\circ 19'$
f	= 160° 42'	$c \wedge f = 43^\circ 41'$
c	= 117° 1'	
f'	= 73° 23'	$c \wedge f' = 43^\circ 38'$
y'	= 55° 41'	$c \wedge y' = 62^\circ 21'$
cy	= 62' 20	$c \wedge f = 43^\circ 39'$

The parameters and indices of these two forms are determined as follows: as they are in the brachypinacoidal zone they will be parallel to the \bar{a} axis. In Fig. 308, make ob equal to unity on the macroaxis and draw the vertical axis at o , then draw bf making the angle $obf = 43^\circ 39'$; if oc is unity on \bar{c} , then of is twice oc or $2c$ and the parameters and indices of the form f are $\infty \bar{a} : \bar{b} : 2 \bar{c}$, (021).

In the same way draw by , making the angle $oby = 62^\circ 20'$, then oy is $4c$ and the

b

FIG. 308.

parameters of y are $\infty \bar{a} : \bar{b} : 4 \bar{c}$ and its indices are (041). The parameters and indices of any other form occurring on the crystal may be determined in a similar way, and with the data obtained the crystal may be drawn, by consulting the chapter on the drawing of crystals.

CHAPTER IX

OPTICAL PROPERTIES OF CRYSTALS

It has been shown that crystal forms are dependent upon and are the result of a definite arrangement of the molecules. In some cases substances which differ chemically may crystallize with almost the same angles and forms. Again, substances which, upon chemical analysis, as pyroxene and amphibole, may yield the same percentage result, crystallize with angles which are different. Such substances may be easily identified when comparatively large specimens and well-developed forms are at hand; but when in small fragments, even chemical analysis will fail, and yet each fragment will possess the peculiar molecular arrangement in which the one species will differ from the other, and in this case pyroxene from amphibole.

It is well known that light in its passage through any medium is modified in its velocity, direction, and vibrations. These various modifications of transmitted light are the effect, in part, of the molecular arrangement, and these effects are constant and characteristic. They are therefore reliable when used in the identification of crystalline compounds, and just as much so as chemical tests, while in many cases they are much less troublesome in their application. According to the accepted theory, light is propagated in a medium which heretofore has been purely imaginary, but at the present time evidence is being brought forward, and from several sources, which would seem to prove the actual existence of this imaginary medium, the ether. Light is propagated and is the effect of very rapid oscillations or electric polarization of the ether. These oscillations are periodical and transverse to the ray of light or direction of transmission. They are exceedingly rapid alterations of the electromagnetic conditions of the ether, which vibrate back and forth, or rotate in a plane at right angles to the direction of propagation.

That light is an electric effect is substantially proven from its analogy to the electric waves used in the transmission of wireless

telegraphy They both travel with the same velocity of 185,400 miles per second, and may be polarized, reflected, deflected, and refracted. The wireless waves are very large, while those waves which our eyes are able to detect as light are very small. The range of our eye as a detector is limited to those waves which fall within the colored spectrum; but that waves, both smaller, as the ultra-violet waves, and larger, as the infra-red waves, do exist we know from other detectors, and our eyes are not able to recognize these waves as light. The ether pervades all space, both the interstellar and the intermolecular, and penetrates even within the atom itself, filling the space between the electrons which compose it. The interatomic space is probably as accessible to the ether as the space within a stack of bird cages is to the air, and yet light travels faster in a vacuum than in space filled by a gas or a transparent solid. It is through this modification of the velocity and vibration of the light wave, as it passes through a substance, that the optical properties of any particular crystal become apparent. Light may be considered as transmitted through a given medium by means of waves set up in the ether. The periodic changes which constitute these waves take place at right angles to the line of propagation, and in this respect they are known as transverse waves vibrating back and forth in all planes across the line of direction of transmission. The ray is a term conveniently used to denote the direction along which the wave advances.

As an illustration of the terminology of wave and wave motion it is best to select, as an example, one in which there is possibly no imagination required, as is the case of the wave motion on the surface of water.

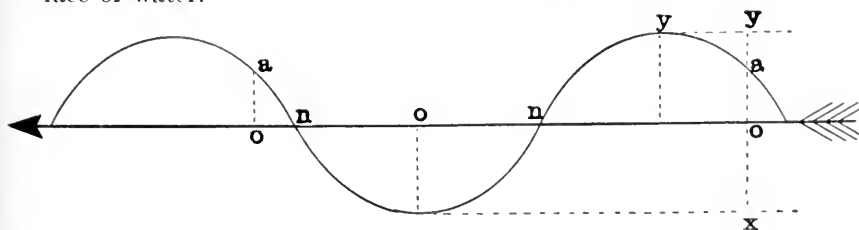

FIG. 309.

In Fig. 309, the position of any particle of water, as *a*, on the surface will determine the wave surface at that point; as *a* falls toward the arrow, the water surface falls and the wave passes on until *a* reaches a maximum depression *x*, when the valley of the wave *x* is formed; then *a* rises until it reaches a maximum position above

the arrow at y , when at that instant another crest is passing the point y . Each time that a completes the path between x and y , and returns to its original position, moving in the same direction, an entire crest and trough have passed, or one wave length, denoted by λ . The wave length is the distance oo , measured between the paths of the two particles aa , occupying the same position in regard to the arrow and traveling in the same direction; such particles are said to be of like phase. The period is the time that is taken by any particle to complete the swing back and forth and to return to its original position and condition. The amplitude is the distance $oy = ox$ from the median line to the highest point in its path. It is also to be noted that the particle a moving back and forth along the path yx is not carried forward along the arrow, but like a block of wood rises and falls on the waves. A wave front is formed by the particles or points which are influenced simultaneously as each wave passes them; they are all in the same phase and form a surface or line at right angles to the direction of transmission, at any particular point. When the wave surface is a curved surface, the plane tangent at any particular point will be at right angles to the ray or the direction of transmission at that point. All the above terms are equally applicable to the light wave, but just what the change of conditions along the path xy is, is still somewhat in doubt.

The intensity of light is proportional to the square of the amplitude, and the color will depend upon the length or more correctly on the periodicity or number of vibrations per second of the wave. Deep violet light at one end of the spectrum has a wave length of .000396 mm., while dark red at the other end has a wave length of .000795 mm., or about double that of violet, and the yellow sodium light is about halfway between these two, or .00059 mm. Vibrations larger or smaller than these the eye is unable to detect as light; but that heat rays do exist above and actinic rays below is easily demonstrated by detectors other than the eye.

Light waves of all lengths travel in a vacuum with the same velocity, but they differ in their period, since short waves, as violet, must vibrate twice as quickly as the red waves, which are double their length. Upon entering a transparent medium the velocity of light of all wave lengths is modified; the extent of this modification will depend both upon the medium through which the light is traveling and upon the wave length or color of the light; so that lights of different wave lengths will vary in their velocities upon

passing from one medium into another. Substances differ greatly in the way they transmit light; one class, known as **isotropic substances**, transmits light equally or with the same velocity in all directions. If a point within such a transparent isotropic substance be imagined as the source of light, the light waves will travel in all directions from this point with the same velocity, and if it were possible to stop the wave at any instant, say after an inch had been traversed from the point of emission, the extreme wave front would be a sphere of an inch radius. Every point of the surface would be one inch from the source of light, and each ray would have traveled exactly the same distance, whatever the direction.

Isotropic substances include all gases, most liquids, amorphous solids, as glass, and crystals of the isometric system. Solids, however, when under stress or strain and which under normal conditions are isotropic may show anomalies and apparently belong to the second class, or **anisotropic substances**; in which the wave front is not a sphere and the velocity of the transmitted ray will vary with the direction.

In anisotropic substances the velocity of light will vary with the direction in which the light is traveling, but in parallel directions within the same medium the velocity will be the same.

The anisotropic class includes the tetragonal, hexagonal, orthorhombic, monoclinic, and triclinic systems of crystals, and also isometric and isomorphous solids when under stress or strain, as well as those liquid crystals which show double refraction.

The wave front in anisotropic substances is not a sphere, but its form will depend upon the substance.

When light strikes the surface of a transparent substance, as glass, it is modified in several ways: (1) some is reflected; (2) some is refracted; (3) some is polarized; (4) some is absorbed or lost as light, as it is transformed to energy of another kind. All four effects will depend upon and will vary with the nature of the surface, the angle of inclination of the ray, and the substance.

Reflection. — If from the head of the arrow, in Fig. 310, a ray of light is traveling in the direction ao , it will strike the surface ss' at the point o . The reflected portion will travel along and in the direction of oa' with a velocity which is unchanged. The two directions ao and $a'o$ will be symmetrical in regard to the normal no at the point of incidence, and will lie in the same plane. The angle aon is the angle of incidence = i = the angle noa' , the angle of reflection. The ray from b , traveling in the same direction and with

an equal velocity as that from *a*, will strike the surface at point *P* and will be reflected in the direction of *Pb'*. When the wave front is at *a'*, the ray from *b* will be at the point *b'*, for the path *aoa'* is equal to the path *bPb'*, and the arrow will appear as at *a'b'*, but in a reverse position. If the surface of reflection is a truly plane surface, the image of the arrow at *a'b'* will be of the same size and shape.

Refraction. — When the ray, in Fig. 310, from *a* strikes the surface at *o*, a portion of the light, depending upon the angle of incidence and the character of the substance, is transmitted or penetrates the second transparent medium. The velocity and direction of the entering light will be changed; the amount of change will

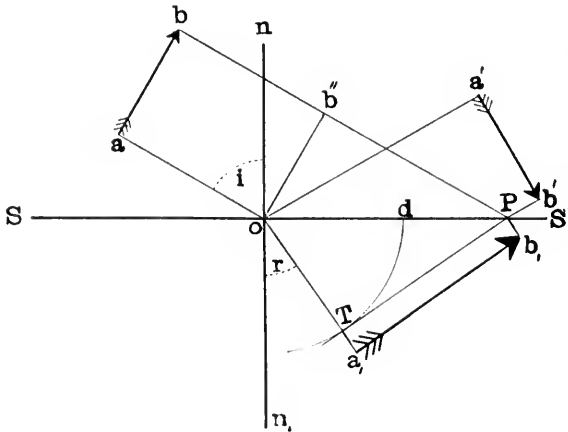

FIG. 310.

depend upon the medium and the wave length of the entering light. Suppose the upper medium to be air and the lower medium to be water; light travels approximately three quarters as fast in water as in air. The ray *ao*, in Fig. 310, will be on the point of entering the water at *o*, when the ray from *b* is at the point *b''*; while *b* is traveling the distance *b''P*, *a* will have traveled three quarters of this distance in water. To find the wave front of the refracted rays: draw *bP* parallel to *ao*, then with *o* as a center and radius equal to three quarters of *b''P* draw the circle *dT*; from *P* draw *PT* tangent to the circle *dT* and *PT* will be the direction of the wave front of the refracted rays. When *b* reaches *b1*, *a* will be at *a1* and the arrow will appear at *a1b1*, enlarged, but not reversed, as is the case with the reflected rays. A man standing on the bank will

appear, to a fish in the water, one and one half times taller than he really is; while the fish will appear smaller, as the rays follow the same paths in the reverse direction. The angle $a_1on_1 = r =$ **the angle of refraction.**

In passing from a rare medium to one which is more dense, the ray is bent toward a perpendicular; and in passing from a dense medium to one which is less dense, the ray is bent from the perpendicular.

The angle of refraction will vary with the angle of incidence, but there is always a relation, as the value of $\frac{\sin i}{\sin r}$ is a constant.

In Fig. 310, in the two right-angled triangles $ob''P$ and oTP , the side oP , or hypotenuse, is common to both triangles. The angle $b''oP = noa = i$, the angle of incidence, and $TPo = Ton_1 = r =$ the angle of refraction. $Pb'' = v$, the velocity in air, and $oT = v_1$, the velocity in water; then

$$\begin{aligned} Pb'' &= oP \times \sin b''oP = oP \times \sin noa \\ &= oP \sin i, \text{ or } v = oP \times \sin i; \\ oT &= oP \times \sin TPo = oP \times \sin Ton \\ &= oP \times \sin r, \text{ or } v' = oP \times \sin r, \end{aligned}$$

or
$$\frac{v}{v'} = \frac{\sin i}{\sin r}.$$

As the velocity of light of the same wave length is, in water, always the same, no matter what the direction, and likewise for air, $\frac{v}{v'}$

and $\frac{\sin i}{\sin r}$ are constants.

The ratio $\frac{\sin i}{\sin r} = n$, the **index of refraction of the water.** When air is taken as the unit of comparison, and the velocity of light in air is one, n , the index of refraction of water, is 1.333.

An isotropic substance has a constant index of refraction, whatever the direction of the path of the transmitted ray may be, and for water the index is 1.333. The indices of refraction of a few other liquids and solids at room temperature and for yellow light are as follows:

Ether	1.356
Turpentine	1.472
Benzene	1.502

Oil of cedar	1.520
Oil of cloves	1.540
Canada balsam	1.548
Carbon bisulphide	1.627
Methylene iodide	1.742
Fluorite	1.423
Potash alum	1.456
Crown glass	1.515
Rock salt	1.544
Garnet	1.807
Spinel (Chrome)	2.096
Diamond	2.467
Proustite	3.08

The index of refraction of any substance is different for light of different wave lengths, and also varies slightly with the temperature; as regards the wave length, it is inversely as λ^2 , or for light of long wave length, as red, n the index of refraction is less and the angle of refraction r would be greater than in case of violet light, with a short wave, or the violet ray would be bent more in entering the water, Fig. 310, than the red ray. The violet ray would lie nearer the normal than the red ray. This division of white light into colors is known as **dispersion**.

The relative velocity of light in any substance is the reciprocal of the index of refraction, as, $n = \frac{v}{v'}$; where v , the velocity in air, is

$$1, \therefore v' = \frac{1}{n}$$

Violet light, which has a larger index of refraction in water, will travel more slowly than red.

Critical angle. — In the equation, $n = \frac{\sin i}{\sin r}$, $\sin i$ may have any value between **zero** and **one**; when all values are considered, there are two special cases, those of the limiting values, **o** and **1**. In the case when $\sin i = 1$, or the angle of incidence is 90° , Fig. 311, then $n = \frac{\sin i}{\sin r}$ or $\sin r = \frac{1}{n}$; substituting the value of n in case of water, $\sin r = \frac{1}{1.333}$, or the angle r is $48^\circ 36'$.

When light is traveling along the surface SS' , that entering at any point o will take the direction oa_1 , in which the angle a_1on_1 is $48^\circ 36'$.

This is the maximum value of r for water and air, and is termed the **critical angle**, or the angle of **total reflection**; for if a ray, as oa_{11} , should reach the surface at the point o , in which the angle $a_{11}on_1$ is greater than $48^\circ 36'$, the critical angle for water and air, there is no possible value for $\sin i$ and no light could pass out of the water into the air, but all is reflected back along the direction of oa_{11} . Viewed from a_{11} under suitable conditions, there will be a light field outside of the critical angle of $48^\circ 36'$ and a dark field inside of this angle, as indicated by the circle in the figure. The dividing line between these two fields will measure the critical angle.

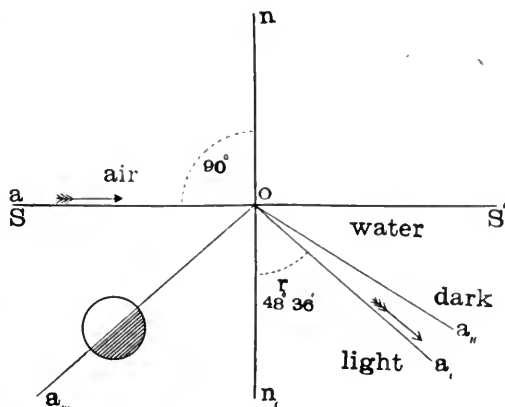

FIG. 311.

By measuring the critical angle of any substance, its index of refraction is easily determined, as $n = \frac{1}{\sin(\text{of the critical angle})}$.

The determination of the index of refraction by the total refractometer is based upon this principle.

The minimum value of $\sin i$ is 0; then $n = \frac{\sin i}{\sin r}$ becomes zero, or there is no refraction, and light passing in the direction of the normal to the surface is not refracted.

All isotropic substances have but one index of refraction, for the reason that light is transmitted with the same velocity in all directions; the wave front is a sphere. In anisotropic substances there are two and even three indices of refraction, and the velocity of light varies with the path followed through the crystal. The wave front is no longer a sphere, as in isotropic substances, but its shape and curvature will depend upon the substance.

The wave fronts in anisotropic substances are surfaces all of which agree in being symmetrical to three planes of symmetry at right angles, as the axial planes of the orthorhombic system. These three planes intersect each other in three straight lines at right

angles to each other. Each of these lines represents a direction parallel to which there is a maximum or minimum index of refraction or velocity, for transmitted light. The relative length of these axes will also represent the relative speed of transmission, remembering that the velocity is the reciprocal of the index of refraction.

Double refraction. — A ray of light upon entering an anisotropic crystal or substance, in general, travels with two different velocities within the crystal, or it is broken into two rays, each of which possesses its own index of refraction. In other words, one is a slow ray, the other is a fast ray. The difference between the values of the indices of refraction of the two rays is a measure of the **birefringency** of the substance in that direction, for the **birefringency** or **double refraction** varies with the direction of transmission.

For calcite one index of refraction = 1.658 and the other = 1.486; as these are the maximum values, or represent the maximum difference between the two indices, their difference, or .172, would be the double refraction of calcite; which is very high or strong.

In most minerals it is represented by a small figure in the second decimal place, or even in the third, as that for quartz is .009 and that for orthoclase is .007. Since calcite is an example of birefringency in an exaggerated degree, and it is transparent and easily obtained, it is an extremely good mineral with which to demonstrate this peculiar property of crystalline substances.

The usual cleavage piece of calcite is a rhomb in shape. If such a cleavage piece of calcite be placed over a pinhole in an opaque paper and then held up to the light, two pinholes will appear,

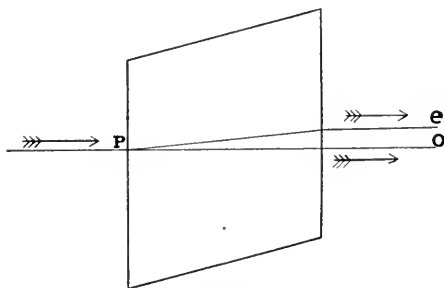

FIG. 312.

Fig. 312; one will be seen above and nearer than the other; this is due to the difference of the velocities of the two rays. The distance between the two images will depend upon the thickness of the calcite. When the rhomb is revolved, one image *e*, Fig. 313, will appear to revolve

around the other, or that ray is refracted to a greater extent than is the other ray. In fact, when the ray of light enters the calcite at right angles to the surface and the eye is in the direction of this ray, when the rhomb is revolved one image is sta-

tionary, and this is what would be expected if the crystal were an isotropic substance, as there is no refraction when the ray falls normal to the surfaces. This ray follows the ordinary law and is therefore termed the **ordinary ray**. Its index of refraction is written ω . In the case of calcite the index measured with monochromatic sodium light (yellow) is written, $\omega_y = 1.658$. The second ray follows another law which is entirely different from that of the ordinary ray, and its velocity and therefore its index of refraction (written ϵ) will vary with the direction; this ray is known as the **extraordinary ray**. The index of refraction taken at its maximum difference from that of the ordinary ray and for sodium light is written $\epsilon_y = 1.486$.

When the index of refraction of the extraordinary ray is smaller than that of the ordinary ray, or the extraordinary ray is the fast ray, $\omega > \epsilon$, the crystal is said to be **optically negative**, written $(-)$ as in calcite.

In quartz, where $\omega_y = 1.544$ and $\epsilon_y = 1.553$, $\epsilon > \omega$, it is **optically (+)**, and the extraordinary ray is the slow ray.

All crystals of the tetragonal and hexagonal systems have two indices of refraction; one, that for the ordinary ray, is constant for all directions in the crystal, as in isotropic substances; the other, that for the extraordinary ray, varies with the direction in the crystal, from the value of the index of refraction for the ordinary ray as one limiting value, to a maximum or minimum as the other limit, according to the $(-)$ or $(+)$ character of the crystal.

Wave surfaces in hexagonal and tetragonal crystals. — In Fig. 314, if any point within a hexagonal or tetragonal crystal, as o , be illuminated, and act as the source of light for the smallest fraction of a second, that portion illuminated will be bounded by the wave front. Its distance from the source of light o , in any direction, will depend upon the velocity with which the ray travels through the crystal in any given direction. At the end of any short period of illumination the ordinary ray ω has traveled the distance ox ; as the ray travels with the same velocity in any and all directions, the circle with o as a center and a radius ox will represent the

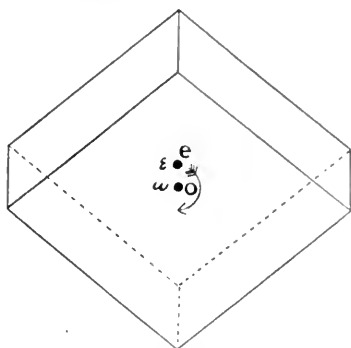

FIG. 313.

section of the spherical wave front, in the plane of the paper. The extraordinary ray travels with a velocity which varies with the direction; the minimum value of which, let it be supposed, is in

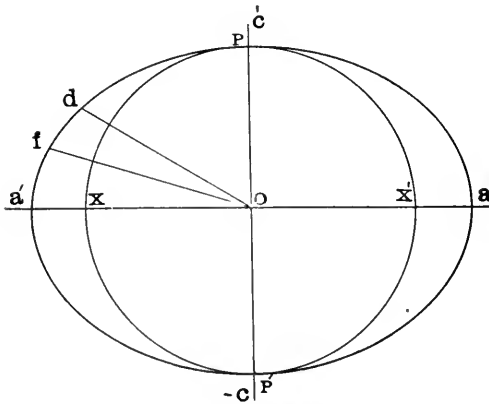

FIG. 314. — Negative.

the direction of the c axis and is equal in this direction to that of the ordinary ray ox . They will both arrive at p and p' on the c axis simultaneously, or for light traveling through the crystal parallel to the c axis there is only one index of refraction. Crystals of the tetragonal and hexagonal systems are **isotropic**

in the direction of their c axis only; such crystals are **optically uniaxial**. The direction in which the extraordinary ray travels with a maximum velocity is at right angles to the c axis or parallel to it according to the optical sign. Let it be supposed the crystal is calcite (-), the maximum velocity will therefore be in the plane of the lateral axes, or the basal plane; this is true for any direction in this plane from o . Let this maximum value be represented by oa .

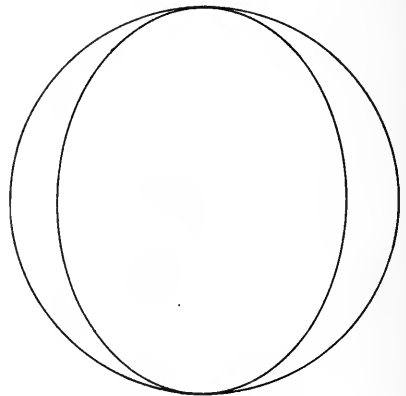

FIG. 315. — Positive.

The cross section of the wave front parallel to the basal plane is a circle. Intermediate values between po and oa , as in the direction of od or of , when plotted on the plane of the paper, form an ellipse, which is similar for all plane sections containing the c axis. The whole wave front of the extraordinary ray is an ellipsoid of revolution, the axis of which is the c axis, or is parallel to the optic axis. The ellipsoid of revolution or wave front of the extraordinary

ray is tangent to the sphere or wave front of the ordinary ray at two points p and p' , where the crystallographical axis c cuts them. The sphere in this case, that of calcite, an optically negative crystal, is entirely inclosed by the oblate ellipsoid. In the case of quartz, an optically positive crystal, the wave front of the extraordinary ray is represented by a prolate ellipsoid of revolution, which is inclosed within the circle or sphere, as represented in Fig. 315.

Optically biaxial crystals. — The wave front in crystals of the orthorhombic, monoclinic, and triclinic systems is not an ellipsoid of revolution, but a combination of two wave surfaces, one within the other, continuous at four depressions, Fig. 316, or symmetrical points, the position of which depends upon the relative values of the three indices of refraction. This fourth dimensional surface is, however, symmetrical to three planes of symmetry intersecting each other at right angles, in three straight lines, analogous to the axes and planes of the orthorhombic system. The three lines of intersection always represent directions within the crystal parallel to which there is a maximum or minimum velocity of light, as all such crystals have three indices of refraction. They are represented by α , β , and γ . The mean index of refraction is $\frac{\alpha + \beta + \gamma}{3}$, and $\gamma - \alpha$ will always represent the greatest double refraction, as γ is the greatest and α the smallest index.

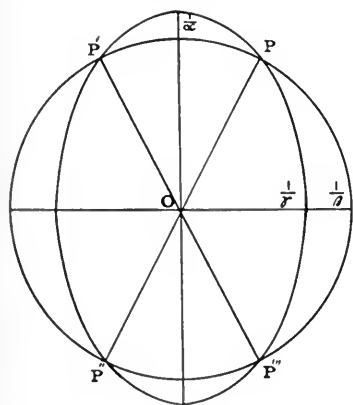
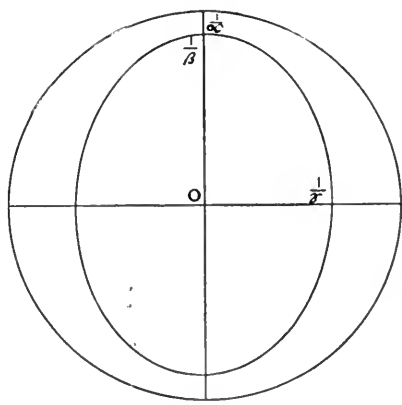

FIG. 316.



• FIG. 317.

Sections of the wave front in the three planes of symmetry are represented in Figs. 316, 317, 318. It will be noted that in each case there is a circle and an ellipse, or for each of these sections there are

two rays, one of which has a constant index of refraction within the plane and is therefore an ordinary ray; the other, represented by the ellipse, is variable in its velocity, and is an extraordinary ray. In Fig. 317 the radius of the large circle represents the maximum velocity $\frac{1}{\alpha}$, and the inner ellipse the variable ray with its two limiting values

$\frac{1}{\beta}$ and $\frac{1}{\gamma}$; Fig. 318 represents the conditions in the plane of symmetry at right angles to \mathbf{a} , in which the inner circle is the minimum velocity $\frac{1}{\gamma}$ and in which γ is the ordinary ray. The diameters of the ellipse represent the variable rays; in Fig. 316 the conditions in the third plane of symmetry are represented, or the intermediate value

$\frac{1}{\beta}$ represents the velocity of the constant ray, the circle, and the ellipse represents the maximum velocity $\frac{1}{\alpha}$ and the minimum velocity

$\frac{1}{\gamma}$ in the crystal; in this section the ellipse and circle cut each other at the four points \mathbf{P} , \mathbf{P}' , \mathbf{P}'' , \mathbf{P}''' , which represent the depressions in the wave surface and are the four points at which the inner and outer surfaces are continuous.

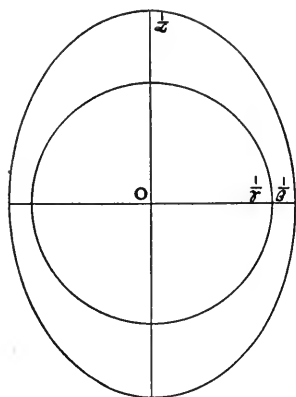

FIG. 318.

The two directions \mathbf{PP}'' and $\mathbf{P}'\mathbf{P}'''$ are the two **optic axes**. Parallel to these two directions there is no double refraction, and the section of the wave surface perpendicular to the optic axis in each case is a circle, as was also the condition in uniaxial crystals. Strictly these two lines \mathbf{PP}'' and $\mathbf{P}'\mathbf{P}'''$ are the **secondary optic axes**, but the **true optic axes** are so near them as not to be separable from them in practice. In any section of the wave front other than in the three planes of symmetry and

parallel to an optic axis, light will travel with two velocities or rays, neither of which will be an ordinary ray, but both will vary in speed with the direction of transmission.

It is seen, Fig. 316, that the two optic axes, the direction of the greatest velocity, and at right angles to it the direction of the least

velocity, are all contained in the one plane; this plane is known as the **plane of the optic axes** or **axial plane**, abbreviated to (**Ax. Pl.**). The line bisecting the smaller angle between the optic axes is the **acute bisectrix** (**Bx_a**) or **first median line**; the line bisecting the larger angle is the **obtuse bisectrix** (**Bx_o**). The internal angle between the acute bisectrix and the optic axis is represented by **V** and **2 V = pop'**, the angle between the optic axes, always less than 90° and measured within the crystal. When measured in air the angle is designated **2 E**; **2 E** owing to refraction is always larger than **2 V** and is often 180° from total reflection. The value of **2 V** varies with different substances and will depend upon the indices of refraction. When the three indices are known, the angle **2 V** may be calculated from the formula:

$$\tan V = \sqrt{\frac{\frac{1}{\alpha^2} - \frac{1}{\beta^2}}{\frac{1}{\beta^2} - \frac{1}{\gamma^2}}}$$

As the indices of refraction vary with the wave length or color of light, it will be seen that **2 V** for violet light will differ from the value of **2 V** for red light; their difference will measure the **dispersion of the optic axes**.

The optical sign of **biaxial crystals**. — The intermediate index of refraction **β** in different biaxial crystals may vary from **α** as a minimum to **γ** as a maximum limit.

In Fig. 319, as the value of **β** decreases the circle **ycy'** will approach the circle **xyx'** and the radius **oc** will approach **ox**. (The figure is drawn with the three axes **ox**, **oy**, and **oz** proportional to the indices of refraction.) The four points marked **c** will

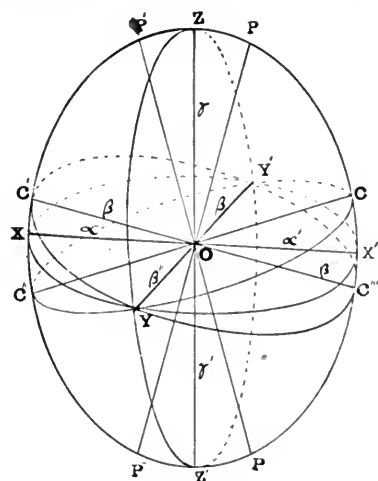

FIG. 319.

draw nearer to **x**, while the optic axes, perpendicular to these circular cross sections, will also draw nearer each other, constantly decreasing the angle **2 V**, **pop'**; when **β = α**, **c** reaches **x** and **p**, **p'** reaches **Z**; in which case the angle between the optic axes is zero and the cross

section is a circle, and the ellipsoid is one of revolution, with z as the axis of revolution, analogous to the prolate ellipsoid in quartz. In such cases, where z is the acute bisectrix and the value of β is nearer to a than to γ , the crystal is said to be **optically (+)**. On the other hand, when the point c moves up toward z , the value of β will increase, and the angle $2V$ will increase constantly until it is greater than 90° , when the line oz will be the obtuse bisectrix and ox the acute bisectrix; when c reaches z , the ellipse will be an oblate ellipsoid of revolution, analogous to that of calcite, and the crystal is said to be **optically negative (-)**.

The three axes of the ellipsoid are usually written $X = a = \alpha$, $Y = b = \beta$, $Z = c = \gamma$.

The relations of the axes of the ellipsoid to the crystallographical axes in the orthorhombic, monoclinic, and triclinic systems vary with the possible conditions, depending upon the symmetry of the system and the relation of the axial plane of the ellipsoid to the planes of symmetry in the system.

In the orthorhombic system, where the three crystallographical axes are at right angles to each other, these correspond in direction to the axes of the ellipsoid, and the position of the planes of symmetry of the ellipsoid is fixed parallel to the planes of symmetry of the system. The axes X , Y , or Z may correspond with any one of the crystallographic axes, but for

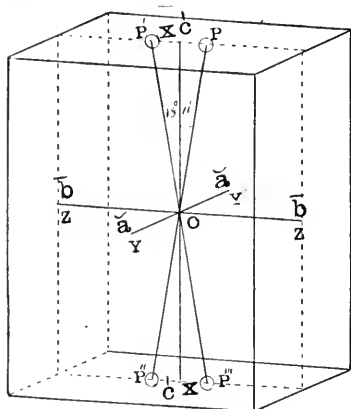

FIG. 320.—Diagram of the Optical Properties of Aragonite.

any one species this relation is definite, as is shown in Fig. 320, a diagram of the optical conditions in the mineral aragonite, where the plane of the optic axis is parallel to the macropinacoid ($Ax. P1. = 100$). The acute bisectrix is $X = c$, the crystal is therefore (-); $\bar{b} = Z$, $\bar{a} = Y$; $2V = 18^\circ 11'$.

In the monoclinic system, the plane of symmetry of the system is parallel with one of the planes of the ellipsoid and the orthoaxis \bar{b} is parallel to one of the axes of the ellipsoid, this axis is therefore fixed; the other two must lie in the plane of symmetry of the system; but their relation to the \bar{a} or \bar{c} crystallographical axes will vary with the mineral species, and their relation is characteristic

of the species. The axial plane may hold one of two positions: (1) parallel to the plane of symmetry of the system; and (2) at right angles to it.

Figure 321 represents the optical conditions in the mineral wollastonite. The axial plane is parallel to 010 ($Ax. Pl. = 010$), with X as the acute bisectrix ($Bx_a = X$), optically (-). The angle between the acute bisectrix and the axis c is $32^\circ 12'$ in the acute angle β , or expressed ($Bx_a \wedge c = 32^\circ 12'$ behind); $2V = 40^\circ$.

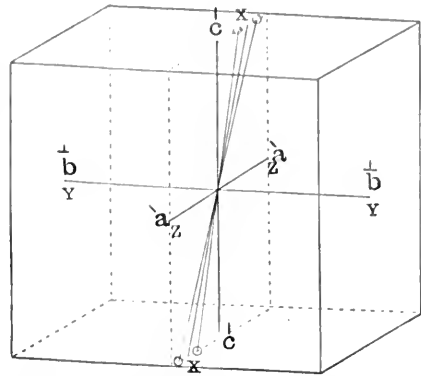

FIG. 321.—Diagram of the Optical Properties of Wollastonite.

In the triclinic system, where, at most, there is only a center of symmetry, there is no relation between the optical ellipsoid and the crystallographical axes, but usually the plane of the optic axes is fixed in any given mineral species. In the description of the optical properties of the triclinic minerals the plane of the optic axes is located by measuring the angle between its trace and some convenient edge, or by any convenient method. In the case of axinite, the acute bisectrix is normal to 111. The trace of the plane of the optic axes on 111 makes an angle of 40° with the edge 111/110, and $24^\circ 40'$ with the edge 111/111.

POLARIZED LIGHT

In ordinary light the vibrations are not restricted to any one plane, as the plane of the paper, in Fig. 322, but take place in all

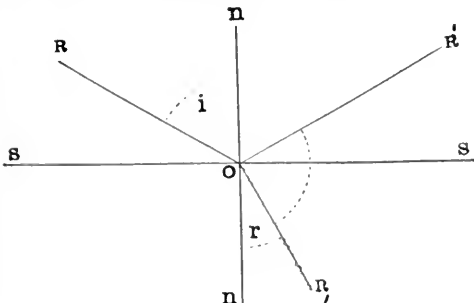

FIG. 322.

possible planes intersecting in the ray as an axis, thus the vibrations of the ordinary beam of light are very complex. When such a complex ray strikes the polished surface of a transparent substance, a portion of both the reflected and

the refracted ray is modified and the vibrations of the modified portion are restricted to one plane. The amount of this modified light will depend upon the angle of incidence, the character of the surface, and the substance. Light in which the vibrations take place in one plane only is termed polarized light, or **plane polarized light**; when the vibrations are in circular orbits, **circular polarized**; and when they are in elliptical orbits, **elliptically polarized**.

Both the reflected and refracted ray are completely polarized when the angle between them is 90° , or, as Brewster's law expresses it, $\tan(\text{angle of polarization}) = n$ (the index of refraction). In case of rock salt, $n = 1.544$, or the angle of polarization would be $57^\circ 5'$; when, in Fig. 322, the angle $noR = 57^\circ 5'$ in case of rock salt and air, the angle $R'oR_1$ would be 90° and both the reflected ray oR' and the refracted ray oR_1 are completely **plane polarized**. The vibrations in the reflected ray take place at **right angles** to the plane of the paper and the ray is said to be polarized in the plane of the paper, parallel to the plane of incidence RoR' . In the refracted ray, the vibrations take place parallel to the plane of the paper, and it is said to be polarized in the plane perpendicular to the plane of the paper, and at **right angles** to the plane of incidence. The two rays after polarization are vibrating in planes at right

angles. This is the condition in all isotropic substances.

In anisotropic substances, in case of refracted light, both the ordinary and extraordinary rays are completely polarized, their vibration planes are at right angles and rigidly fixed by the molecular arrangement of the crystal.

In a cleavage piece of calcite, Fig. 323, when the four sides of the

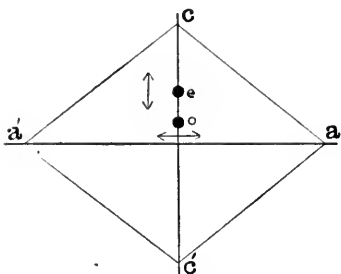

FIG. 323.

rhombic faces are approximately equal, the ordinary ray o upon emerging will be vibrating parallel to aa' , its plane of polarization will be parallel to the short diagonal cc' ; the extraordinary ray e will vibrate parallel to cc' , its plane of polarization will be parallel to the long diagonal aa' , and, furthermore, it is impossible for light to emerge from the calcite the vibrations of which do not conform to either of these two directions. The two vibration planes and planes of polarization are rigidly fixed by the crystalline structure of the calcite.

If in any case, or by any means, one ray, either the *o* or *e* ray, could be absorbed, light passing out of the fragment would be vibrating in one plane only. It is a property of plates of tourmaline that when cut parallel to the \hat{c} axis they absorb one ray, the ordinary, and the extraordinary ray, vibrating parallel to the \hat{c} axis only, is transmitted. All light transmitted by such a section of tourmaline is vibrating in one plane, that parallel to the \hat{c} axis. Such a section of tourmaline, or any other device, used to produce polarized light is termed a **polarizer**, Fig. 324.

When the light, as transmitted by the polarizer, is viewed through another similar section of tourmaline, it will be observed

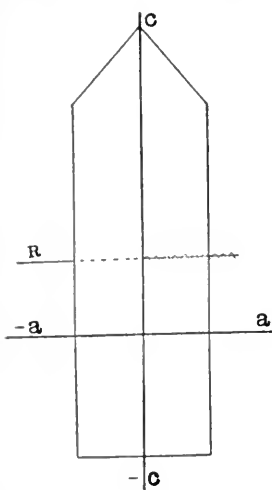

FIG. 324.—Tourmaline Polarizer.

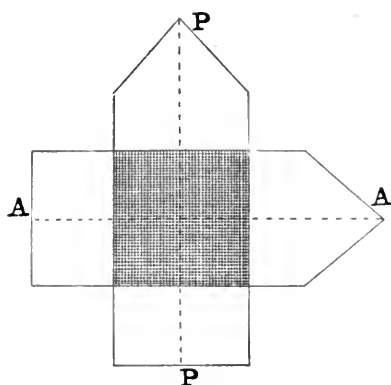

FIG. 325.

at once that the intensity depends upon the relation of the two sections of tourmaline. When the two \hat{c} axes of the sections are at 90° , as in Fig. 325, no light will be transmitted by the second section in this crossed position, and the condition will be that of darkness; the amount of light transmitted by the second section, termed the **analyzer**, constantly increases from zero in the crossed position to a maximum, when the \hat{c} axes of the polarizer and analyzer are parallel. The analyzer allows no light to pass, the vibrations of which are at right angles to its vibration plane; as all light passing the polarizer is thus vibrating, no light can pass when the two sections are in the crossed position, and darkness is the result. As the analyzer is rotated, the amount of light passing increases to

a maximum when the two vibration planes are parallel, and all the light passing the polarizer is transmitted by the analyzer.

Intermediate positions are explained as in Fig. 326; let PP' be the vibration plane of the polarizer and AA' that of the analyzer, bc the amplitude and plane of vibration of light passing the polarizer; according to the parallelogram law in mechanics this wave may be divided into two waves vibrating at right angles to each other, one ce parallel to the vibration plane of the analyzer and with an amplitude ce , the other vibrating at right angles to it and with an amplitude eb ; the ray represented by ce passes the analyzer, while eb at right angles to it is extinguished.

The amplitude of the transmitted ray bf , which illuminates the field of the analyzer, increases from zero in the crossed position, where all light is absorbed, to cb in the parallel position when all the light is transmitted.

Two such sections when mounted in a holder are known as the *tourmaline tongs*, and may be used to test the double refraction and the vibration planes of light in any mineral section placed between them.

If the light reflected from a polished table top is viewed through

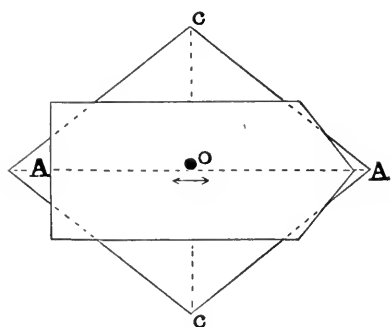

FIG. 327.

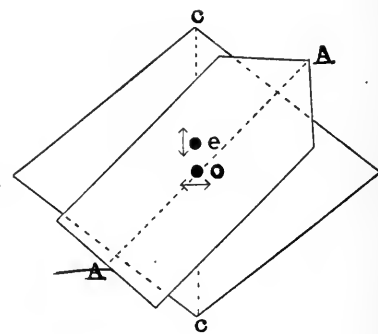

FIG. 328.

one of the tourmaline sections, as an analyzer, on revolving the section the intensity of the transmitted light will be greatest when the long or c axis of the tourmaline section is parallel to the table

top, and least when at right angles to it, showing that some of the reflected light is polarized and that the plane of vibration of the polarized reflected light is parallel to the table top and at right angles to the plane of incidence.

In testing the vibration planes of the two rays transmitted by the calcite rhomb, when the vibration plane of the tourmaline section is parallel to the long diagonal of the rhombic face of the calcite, Fig. 327, only the ordinary ray will appear; its vibration plane must therefore be parallel to this diameter. Upon revolving the tourmaline section, both rays appear and are equal in intensity after a revolution of 45° , Fig. 328. Upon revolving the tourmaline 90° only one ray will appear, the extraordinary ray, the vibration plane of which must therefore be parallel to the short diagonal of the calcite face, Fig. 329. The

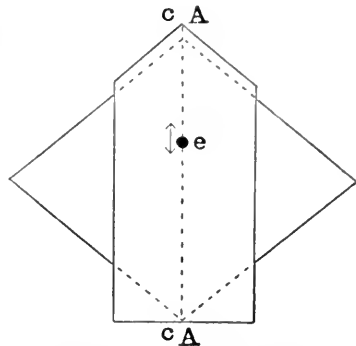

FIG. 329. — Tourmaline Analyzer.

two rays are polarized and their vibration planes are at right angles; this is true of all anisotropic substances.

The nicol prism. — As polarized light is necessary in the study of the optical properties of minerals, and to avoid the natural color of tourmaline sections, Nicol in 1828 devised the instrument now used as the source of polarized light in most optical instruments and known as the **nicol prism** or **nicol**.

It is constructed of clear colorless calcite in such a manner that one ray, the ordinary ray, is internally totally reflected and absorbed, while only the extraordinary ray emerges, thus yielding plane polarized light, all of which is vibrating in one known plane.

Fig. 330 is a section through the short diagonal of a nicol prism, illustrating its construction. A clear, colorless cleavage piece of calcite, three times as long as broad, is cut along the plane PP' perpendicular to the plane of the diagram, from the obtuse angle at P to that of P' . The angle $PP'e$ should be 22° ; the end surfaces are then cut down until the angles $dP'P$ and ePP' are right angles. The two polished halves are cemented together in their original position with Canada balsam, a film of which will separate the two halves and lie along the plane PP' . The cemented calcite is then set in cork, the walls of which next the calcite have been blackened

to absorb any light that may fall on them after being reflected to the sides of the calcite. A ray of ordinary white light on entering a nicol, as at **R**, is divided into an ordinary and an extraordinary ray, having different indices of refraction and traveling different

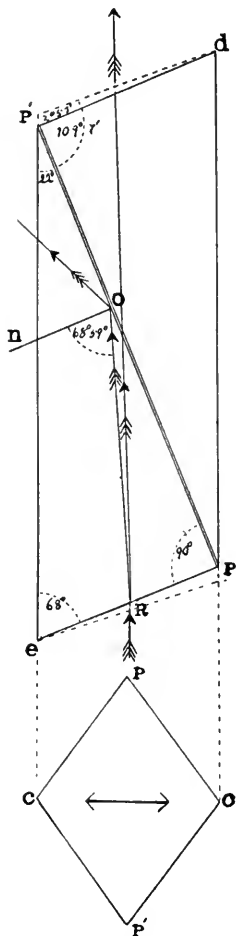

FIG. 330.

paths through the calcite; their angle of total reflection will therefore differ. The ordinary ray, with an index of refraction of 1.658 between air and calcite, is refracted more than the extraordinary ray with an index of refraction of 1.486; this ray will meet the film of Canada balsam at an angle greater than 69° , which is the approximate critical angle of the ordinary ray between Canada balsam and calcite, since $\omega = 1.6583$ divided by the index of refraction of Canada balsam, 1.548, = 1.0712, the index of refraction of the ordinary ray as between Canada balsam and calcite. As between these two media, \sin

$$\left(\text{of the critical angle}\right) = \frac{1}{1.0712} \text{ critical an-}$$

gle = $68^{\circ} 59'$. All ordinary rays meeting the film of balsam at an angle greater than $68^{\circ} 59'$ will be totally reflected in the direction as indicated, and absorbed by the blackened walls of the cork mounting. The index of refraction of the extraordinary ray varies with the direction through the crystal, but in this particular direction it is but little different from that of the balsam, 1.548; its path on entering the calcite is deviated much less than the ordinary ray, and on meeting the film of balsam is but little effected, passing through with little or no refraction, and emerging at the opposite end of the nicol as plane

polarized light, with a vibration plane parallel to the short diagonal **cc** of the rhombic section, and polarized in the plane parallel to the long diagonal **PP'**. Other styles of polarizing prisms have been devised, either to economize space or calcite, as suitable calcite is very scarce and expensive, since the Iceland

supply has been exhausted. They all agree, however, in the principle of totally reflecting either the ordinary or extraordinary ray out of the field.

As usually mounted, the polarizing nicol is under the microscope stage, with its plane of polarization crossing the field, from 0° to 180° on the scale, while the analyzer is mounted in the tube of the microscope in such a way that it may be pushed in or out of the line of vision as required; its plane of polarization is at right angles to that of the polarizer, or in the crossed position.

Interference of polarized light. — Whether we speak of light as due to waves, or to the periodic vibrations or change in conditions, or whether light is due to an electromagnetic disturbance of the ether, it remains nevertheless true, that one disturbance is

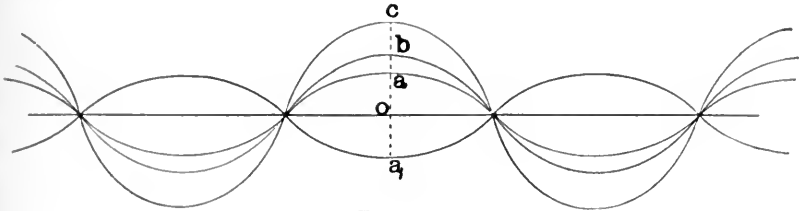

FIG. 331.

influenced by another and may be added to or subtracted from the other, according to the phase of each. If two waves of the same length are vibrating in the same plane and phase, as the two waves **a** and **b** in Fig. 331, but of different amplitudes or intensities, the result is an entirely new wave **c** with an amplitude **oc**, or a wave with an amplitude of $a + b$, and the illumination of the new wave is equal to that of the other two combined. When the waves are in opposite phases, the result is the difference of the two amplitudes, the new wave **a**, with an amplitude **oa** equal to $oc - oa$, and the illumination is decreased. Should the amplitudes be equal and the one wave be a half phase or wave length behind the other, their difference would be zero and darkness would result, or one wave is said to interfere with the other.

When light of the same wave length or color and of the same intensity, *i.e.*, derived from the same source, is polarized in two rays, these two rays will interfere if brought to vibrate in the same plane. The result of this interference will depend upon the conditions of vibration, or how much one wave has been retarded, or is vibrating behind the other.

In Fig. 332, the ray R is reflected at the point o in the direction of oR' . Some of the light, however, enters the medium P and is refracted in the direction oR_1 and at R_1 is reflected in the direction of R_1o' and passes out of the medium P , in the direction $o'R''$. The light, or ray, $o'R''$ is made up of two rays, one which has traveled the path oR_1o' in the medium P , and a reflected ray $r'o'$, which will probably be vibrating in a different phase and therefore in position to interfere.

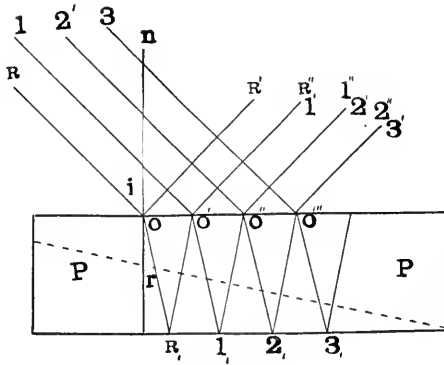

FIG. 332.

If the refracted ray is retarded $1/2 \lambda$ due to the differences of paths and velocities of the two rays while the refracted ray is passing through the medium P , then the eye at R'' will perceive no light, or darkness will result when monochromatic light is being used.

When the medium P is of uniform thickness the relative paths for each ray will be the same for all points and the surface will be uniformly lighted. If the paths within the medium P can be progressively varied, or if the section P is wedge-shaped, as indicated by the dotted line, then the difference of phase between the reflected and refracted rays will increase with the thickness of the wedge, as the internal path followed by the ray

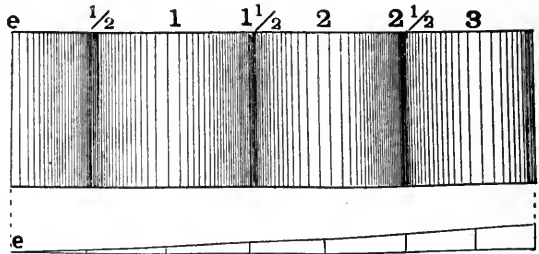

FIG. 333.—Diagram of the Quartz Wedge.

R will be much shorter than the path followed by the ray 2, and on emerging at o' and o''' will be retarded proportionally. At the edge of the wedge, Fig. 333, where the thickness is zero, there will be no interference or diminution in the illumination. As the wedge thickens, the refracted ray will be retarded more and more behind the reflected ray, with a decrease of the illumi-

nation until the refracted ray is exactly $1/2$ a wave length behind the reflected ray, or $1/2 \lambda$, then darkness will be the result. From this point the illumination will increase until the refracted ray is a whole wave length behind the reflected ray, when there will be a maximum illumination. There will therefore be bands of light, representing a maximum light at each whole wave length that one ray is retarded behind the other, as at 1, 2, 3, and there will be a band of minimum illumination at points, as $1/2$, $3/2$, $5/2$, at which one ray is retarded an odd number of $1/2$ wave lengths behind the other. This condition of alternate bands of light and darkness obtains only when monochromatic light is used; when white light is used, which is composed of waves of all lengths or colors, and which differ in their velocities in passing through the wedge, their dark and light areas on the wedge will not correspond, and the area which will be dark for yellow will be light for red, with a result that the surface viewed with reflected light will show color bands (these bands may be seen on the quartz wedge when held at the proper angle). Beginning at the thin edge of the wedge, all the interference colors will have appeared in order, when the retardation has reached one wave length, or λ ; then they are repeated in the same order, when 2λ is reached, and again to 3λ .

These color effects due to the interference of light are well illustrated by the play of colors on soap bubbles; in the iridescent films of carbonates, oxides, or oil on the surface of water; in the cleavage fractures of such a clear mineral as calcite, and in the small internal and irregular fractures of the opal.

Order of colors. — In the series of colors caused by the interference of light, those which appear first, on the thin end of the wedge, or are caused by a retardation of one wave length or less, are termed the colors of the first order; those from λ to 2λ , the second order; and those from 2λ to 3λ , the third order; etc. Above the fourth and fifth orders the individual colors are not well defined and return to the **high order gray**. The lower orders of colors are each characteristic in intensity and tone, and with experience may easily be distinguished; as, for instance, red of the first order, from red of the second or third orders; since the order of color yielded by sections of approximately the same thickness of the various double refracting minerals is a measure of their double refraction, it is most important that one should be able to recognize the colors of various orders. The most important of these are:

FIRST ORDER	SECOND ORDER	THIRD ORDER	FOURTH ORDER
Grays	Purple	Light blue	Indistinct
Straw yellow	Deep blue	Bright green	
Deep red	Light green	Yellowish green	
	Light yellow	Faint red	
	Bright red		

These colors may be compared by use of the quartz wedge, Fig. 334; those produced by the thin edge are of the first order, starting with gray of the first order.

Uniaxial crystals. — It has been pointed out that light in passing through a uniaxial crystal is divided into two rays polarized and vibrating at right angles to each other, one of which travels with the same velocity whatever the direction, while the velocity of the other varies with the direction.

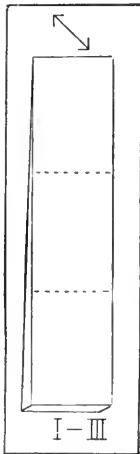

FIG. 334. — Quartz Wedge.

If an ellipsoid, Fig. 335, be constructed in which the three axes are drawn proportional to the three indices of refraction, which are proportional to the reciprocals of the three velocities, this ellipsoid, in the case of uniaxial crystals, will be one of revolution, every plane section of which will be an ellipse; there is, however, one direction, that perpendicular to the optic axis, in which the plane sections are circles, and light is transmitted in the direction of the optic axis without double refraction. The radii vectores of the elliptical section will be a measure of the indices of refraction of the two possible rays passing through the crystal in a path at right angles to the section, and their directions will also indicate their planes of polarization.

Let Fig. 336 be a section containing the axis of rotation of such an ellipsoid, in which ox represents the smaller index of refraction and oz the larger. Light traveling in the direction of zz' is transmitted with a velocity proportional to oz and an index of refraction of ox ; similarly a ray in the direction of xx' is transmitted

with a velocity of ox and an index of refraction of oz . Such an ellipsoid is known as the **indicatrix of Fletcher**.

Any ray whatever, as the ray entering the crystal at R , Fig. 335, will in general be transmitted as two rays. The indices of refraction will be represented by the radii vectores of the elliptical section of the indicatrix, passing through the point o and perpendicular to the direction of the ray, as the ellipse bab' , which in uniaxial crystals contains one diameter aa' , representing the ordinary ray; this diameter is constant in all sections of the indicatrix passing through the point o . The two planes $Rcob$ and Raa' , at right angles to the elliptical section aba' and containing the two diameters bb' and aa' , are the planes of vibration of the two rays; of these the extraordinary ray vibrates in the plane containing the optic axis cc' and the direction of the ray Ro , and termed the **principal optic section**. The extraordinary ray vibrates in the plane containing the optic axis cc' and the direction of the ray Ro , and termed the **principal optic section**. The extraordinary ray vibrates in the plane containing the optic axis cc' and the direction of the ray Ro , and termed the **principal optic section**.

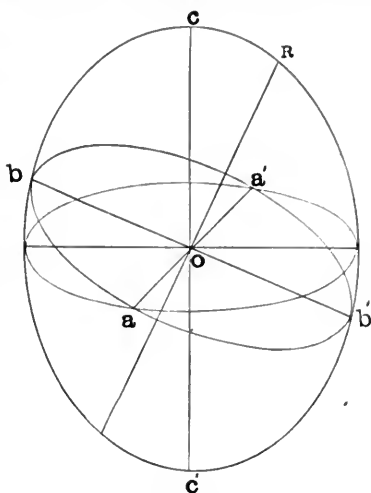

FIG. 335.

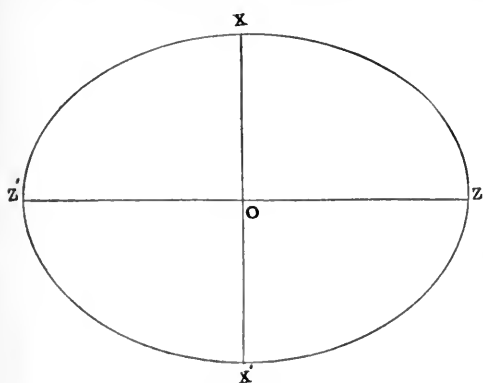

FIG. 336.

The extraordinary ray vibrates in the principal optic section and is polarized in the plane $ROaa'$ at right angles to it. There is one direction in which the two diameters of the elliptical section are equal, that at 90° to the optic axis, or the ellipse becomes a circle and the two rays are transmitted with

the same velocity and with no fixed plane of vibration; they are not polarized.

Angle of extinction. — When a section of a uniaxial crystal, or in fact any double refracting substance with plane parallel faces, is

examined between crossed nicols, it will be found, on rotation of the section between the nicols, that the light will be entirely extinguished, or decrease to a minimum illumination, at every 90° , and the section will be dark. From the point of darkness the illumination increases constantly upon further revolving the section, until a maximum is reached at a point 45° from the point of darkness, and then decreases to a minimum after a revolution of the section through another angle of 90° ; these conditions are repeated four times in the complete revolution of 360° .

Interference of polarized light in passing mineral sections.— Let Fig. 337 be such a section; then light entering the section will be transmitted as two rays vibrating in planes at right angles

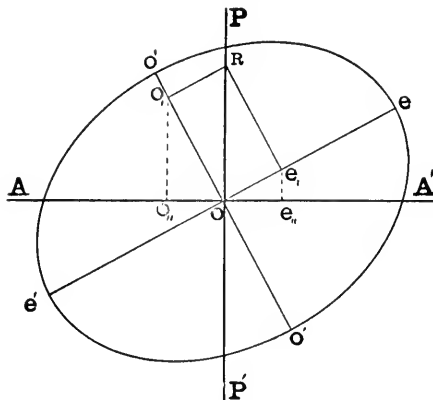

FIG. 337.

to each other. Let $ee'o'o'$ represent the elliptical section of the indicatrix; the two rays will leave the section vibrating in the planes ee' and oo' ; also let PP' and AA' be the vibration planes of the polarizer and analyzer. If RO represents the amplitude and the direction of the vibrations of the plane polarized ray passing the polarizer, then on entering the section this ray will be

resolved into two rays, oo_1 , vibrating parallel to o' , and oe , vibrating parallel to ee' . When the ray oo' enters the analyzer one component oo_{11} vibrating parallel to the vibration plane AA' of the analyzer passes, and passes without diminution, while the other component, vibrating parallel o_1o_{11} at right angles to AA' having no component in the plane AA' is extinguished by the analyzer. The two rays oo_{11} and oe_{11} , vibrating parallel to AA' and therefore in position to pass the analyzer, are also in position to interfere, and the resultant light depends upon this interference. When white light is used, the resulting interference color will depend upon the double refraction of the substance; upon the direction of the section in the crystal; and upon the thickness of the section.

When monochromatic light is used and one ray is retarded behind

the other one wave length in passing the section, or any multiple of whole wave lengths, oo_{11} will be opposed to the vibrations of oe_{11} and there will be darkness during a complete revolution of the section. The conditions are the same as in the quartz wedge, but here the half wave of the nicol is added.

As the vibration planes of every mineral section are absolutely fixed, they may be determined, and if necessary their traces marked, on the section; if the section is revolved until there is a minimum amount of light or darkness, as viewed through the analyzer, between crossed nicols, then the traces of the vibration planes of the section will be parallel to the vibration planes of the analyzer and polarizer or to the cross hairs in the eyepiece. One of these planes is the principal optic section or contains the optic axis, which in uniaxial crystals is parallel to the \hat{c} crystallographical axis. It follows that in all sections through the crystal parallel to the prism zone one of the vibration planes of the section will be parallel to prismatic or pinacoidal cleavage cracks in the section, or at right angles to them. Darkness will occur on viewing the section in the microscope when one of the cross-hairs is parallel to the cleavage cracks; the section under these conditions is said to possess **parallel or straight extinction**.

The extinction angle of any section is measured by the cross hairs in the eyepiece of the microscope. They are set parallel to the vibration planes of the nicols; then when extinction occurs on revolving a mineral section on the stage, the vibration planes of the section are parallel to the cross hairs. A reading is taken from the graduated circle on the stage, then the stage is turned until the cleavage crack is parallel to the hair, when another reading is taken; the difference between these two readings will be the extinction angle of the section. All sections of uniaxial crystals, not parallel to one axis of the ellipsoid, extinguish at angles other than 90° . The extinction angle will vary with the inclination of the section, but extinction is always symmetrical, or divides the angle between cleavage cracks equally.

In basal sections of uniaxial crystals there are no definite vibration planes, and the light passed by the polarizer will pass through the section unchanged, to be extinguished by the analyzer, and the field will remain dark during a complete revolution, as if there were no section at all between the nicols.

Determination of the slow ray. — The slow ray may be determined by means of the quartz wedge. This is cut from a crystal

of quartz in such a manner that one flat side is parallel to a plane containing the optic axis, *i.e.*, the vertical crystallographical axis; the long edge of the wedge, in most cases, is inclined at an angle of 45° to the optic axis. Some wedges are cut with their long edge parallel to the optic axis. In all cases the vibration plane of the slow or extraordinary ray is always indicated on the wedge by an arrow or mark, as in Fig. 334.

In the tube of all petrographical microscopes, just above the objective, is a slot, into which the quartz wedge slips back and forth, in such a position that the vibration planes of the wedge are fixed at 45° to the vibration planes of the nicols.

A section in which the vibration plane of the slow ray is to be determined is placed on the stage of the microscope and revolved to extinction, then placed at 45° from this position, when the vibration planes of the section will lie at 45° to the vibration planes of the nicols and will be parallel to those of the quartz wedge when in position. At this 45° position the section will be evenly colored. Minerals in rock sections are evenly ground to approximately .03 mm. in thickness, and when interference colors of individual species are given they refer to sections of about this thickness. The color will depend upon the thickness of the section, the direction of the section in the crystal, and the double refraction of the substance. As an illustration let it be supposed that the section yields a red of the first order. First order red may be obtained by using a quartz wedge as a section on the microscopic stage, pushing it under in the 45° position until the first red is obtained. A second wedge is now pushed in the slot of the microscope above the objective; as the edge of the second wedge enters the field of vision there will be a change of color noted. Whether the change of color goes up the scale, from red of the first order to purple, blue, green, etc., of the second order, or down the scale to yellow and grays of the first order, will depend upon whether the difference between the vibrations of the slow ray and the fast ray is still increased by the second quartz wedge or decreased. If the slow ray of the section or the first quartz wedge used as a section is parallel to the slow ray of the second wedge (the direction of each is marked on the wedge) which is inserted in the tube of the microscope, the color change is up the scale, or the effect is that of thickening the section. When the vibration plane of the slow ray of the section is at right angles to that of the quartz wedge, upon pushing the wedge in slowly the colors will go down the scale, from red to yellow and gray,

and finally a shadow will appear, or darkness, at which point the difference between the slow and fast rays of the section is exactly equal to that of the quartz wedge, and the wedge is said to **compensate** the section; for this reason the wedge is often termed a **compensator**. When compensation occurs, if the section is removed from the stage, the quartz will show the original color, due to the double refraction of the mineral section before the wedge was inserted. At the point of compensation, if the wedge is pushed farther through, the colors will rise in the scale uninterruptedly to the end of the wedge.

When the direction of the ϵ axis in the section can be determined, either from cleavage cracks or crystalline edges, and the vibration plane of the slow ray is known, then the optical sign of the section is also known; for when the ϵ axis is parallel to the long edge of the quartz wedge and the slow ray parallel to the slow ray of the quartz wedge, the optical sign is the same as that of quartz (+); when the slow ray is at 90° to the slow ray, as marked on the wedge, the sign is opposite to that of quartz (-).

Pleochroism is the unequal absorption of light waves of different lengths. In the case of tourmaline, when the section was thick enough it absorbed all the light vibrating parallel to the basal section and therefore the section appeared dark for light polarized and vibrating only in this direction. When one color or wave of one length is absorbed more than another, the color of transmitted light will change with the direction, or plane of vibration. Minerals in which pleochroism is well marked will appear differently colored according to the vibration plane of the transmitted light. The absorption reaches a maximum when the vibration planes are parallel to the planes of symmetry of the indicatrix. In uniaxial crystals there can be only two directions, parallel to the ϵ axis, and parallel to the basal section. Crystals of this class can show only two maximum absorption directions and are said to be dichroic. In biaxial crystals there are three maximum directions possible, and these are said to be trichroic or pleochroic.

To test a section for absorption or pleochroism, it is placed on the stage and revolved to extinction, then the analyzer is removed and the color of the section noted; it is then revolved 90° and the color again noted. Any difference in color is due to the unequal absorption of the two rays vibrating in the section, as in the first position one vibration plane of the section is parallel to the vibration plane of the polarizer and transmits the light, while in the

second position the second vibration plane is parallel to the plane of the polarizer and transmits the light.

If it is darker when the extraordinary ray is passing than when the ordinary is passing, and the difference is not marked, then it is noted, absorption or pleochroism is weak, $\epsilon < \omega$. If there is a change of color, this is also noted thus: ϵ = green, ω = bluish; such is the case for beryl.

The **dichroscope** is an instrument by means of which the color of the two rays vibrating in planes at right angles to each other may be directly compared, Fig. 338. It is constructed of a cleavage piece of calcite, c , long enough to separate the two images of the square orifice o when viewed from the opposite end, where the lens l magnifies them. One image is due to the ordinary ray and vibrates parallel to the long diagonal of the rhombic section of the

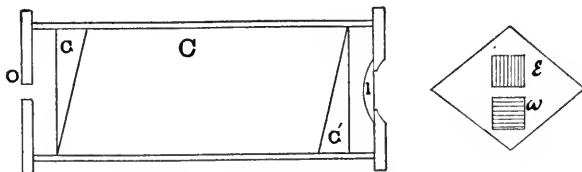

FIG. 338.—Diagram showing the Construction of the Dichroscope.

calcite; the other is due to the extraordinary ray and vibrates parallel to the short diagonal. The ends of the calcite are squared up with the two wedge-shaped glasses G , G' .

Possibly the most remarkable example of pleochroism is shown by thick sections of the mineral iolite, also known as cordierite and dichroite, an orthorhombic mineral, in which therefore three limiting absorption directions are possible, one parallel to each axis. If a smooth surface of iolite parallel to the brachypinacoid is held over the orifice, o , of the dichroscope, and the transmitted light viewed through the lens, one ray will vibrate parallel to the \acute{c} axis and the other parallel to the brachyaxis. The first will be yellow, the second gray—a very marked contrast. If the dichroscope be revolved and the section held stationary, then after a revolution of 90° , the two images will reverse in color. If a section parallel to the base be used, one image caused by the vibrations parallel to the brachyaxis is gray, the same as it was in the first section, but the image caused by the vibrations parallel to the macroaxis will be blue. In the description of a mineral these conditions are expressed for iolite as X = yellow, Y = gray, Z = blue, absorption $Y < Z < X$.

Interference figures in uniaxial crystals. — In a section parallel to the base, it has been shown that when the light ray is passing parallel to the c axis, or optic axis, the section is dark between crossed nicols and remains so during a complete revolution. Sections in any other direction when viewed with parallel rays are of uniform color, provided the section is of uniform thickness. This color effect, caused

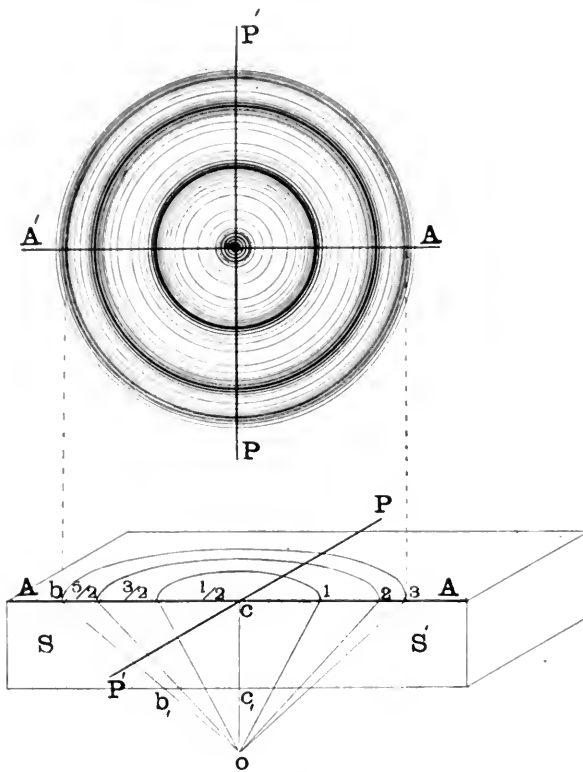

FIG. 339.

by interference, is quite different when viewed with converging light. The path of each ray varies with the inclination of the ray to the section and will be proportionally retarded. The difference between the slow and fast ray will increase with the length of the path, yielding different interference colors when white light is used.

The petrographic microscope is fitted with a strongly condensing lens, which is capable of being easily slipped in the line of vision, directly under the stage, where it is almost in contact with the

mineral section. When in position this lens yields a cone of light, all rays of which will not be transmitted parallel to the optic axis on passing a section, cut parallel to the base, but only those in the axis of the cone of light, Fig. 339, *oc*. This ray will be perpendicular to the section, or parallel to the optic axis, and will be transmitted by the section without double refraction; its vibration plane is that of the polarizer *PP'*, and it is therefore extinguished by the analyzer, and the spot *c* representing the optic axis will be dark. All other rays entering the section, the paths of which are not parallel to *oc*, are doubly refracted. One ray is retarded behind the other, the amount of retardation depending upon the double refraction of the section and the length of the path that the rays travel through the section. As the paths differ and increase in length with the change of the inclination of the rays to the section *SS'*, the path followed as *bb₁* is longer than *cc₁*. The differences of phase of the two rays will increase from the center *c*, where it is zero, equally in all directions on the surface of the mineral section. There will be a point λ where this difference of phase will be one wave length; the cross section of all such waves at right angles to *oc* will form a circle, as indicated on the diagram. These two waves emerging at λ when viewed with the analyzer will be brought to vibrate in one plane and in a position to interfere; as the analyzer adds one half wave length to the difference, the effect will be at the point λ and on the circle with a radius λc , a difference of phase of $3/2 \lambda$, or of darkness if monochromatic light is used.

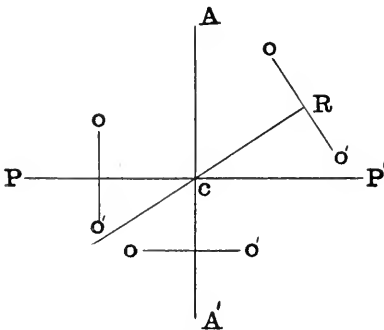

FIG. 340.

Somewhat further away from *c* than λ there will be a circle where the difference in phase will be 2λ as appearing in the analyzer, and a concentric region of maximum light will mark the region, followed by a concentric ring of darkness, etc. The concentric rings of light and darkness will be narrow or close together as the

angle of the inclination to the ray grows smaller or the ray is more inclined. In viewing the interference figure in the microscope, two dark areas, parallel to the vibration planes of the nicols, will be noted as crossing the center or optic axis at right angles and divid-

ing the concentric circles of light and darkness into four equal quadrants. These are caused by the nicols extinguishing the components vibrating perpendicular to their planes of vibration.

Thus in Fig. 340 any ray whatever, as at **R**, upon emerging from the section is divided into two rays: One, the extraordinary ray vibrating in the principal optic section, which contains the ray **R** and the optic axis **c**; the trace of this plane on the section is **Rc**: The ordinary ray vibrates in a plane at right angles to this, as **oo'**; each of these rays will have components vibrating parallel to **AA'** and will pass the analyzer; the point **R** on the section will therefore appear illuminated and with a maximum illumination when the angle **RCA** is 45° , as at this angle the component passing the analyzer is the largest. For any point on **AA'** there is only one component possible, that parallel to **PP'**, and this is extinguished by the analyzer; the line **AA'** is dark. The same conditions hold also for the line **PP'**, which is dark. These two dark regions, parallel to **PP'** and **AA'**, cross each other through the optic axis, Fig. 341.

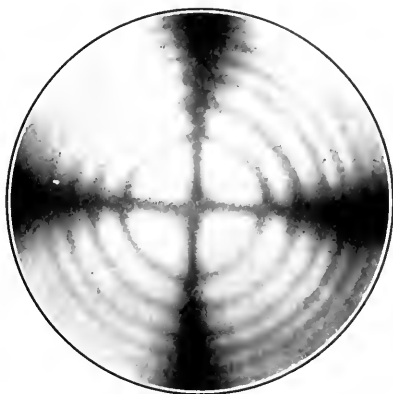

FIG. 341.—Interference Figure of Calcite.

When either the analyzer or polarizer is revolved until their vibration planes are in parallel position, the interference figure is crossed by a single band of darkness, parallel to the plane of vibration of the nicols.

When monochromatic light is used, the interference figure is illuminated with concentric circles of the color used, as yellow, red, or blue; but when white light is used, the concentric rings are colored with the interference colors, as was the case with the quartz wedge. The color nearest the optic axis is violet, then blue, yellow, and on through the colors of the first order to red, after which they are repeated as the second order colors, then the third order colors, and on according to the orders. The dark cross remains the same as in monochromatic light. When the section is cut exactly at 90° to the optic axis, the central dark spot, where the optic axis emerges, will be in the center of the field of the microscope, and the colored rings are also symmetrically

placed in the field; but when the section is slightly inclined, the optic axis will not appear in the center of the field, but

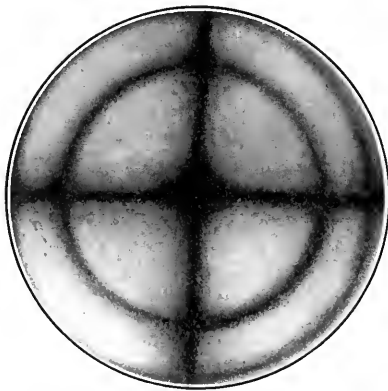

FIG. 342. — Interference Figure of Brucite.

to one side; and when the section is revolved the point where the shadows cross will describe a circle around the axis of the microscope, the diameter of which will depend upon the inclination of the section. When the inclination is large, the optic axis may fall without the field of the microscope and only a portion or segment of the colored circles will show; but still the radii of these quadrants will point to the optic axis. The

dark shadows of the cross will move across the field, on revolving the section, holding parallel positions.

Use of the one quarter wave mica plate in determining the optical sign of a section. — The quarter-wave mica plate is a cleavage piece of mica of such a thickness as to yield an interference color between crossed nicols of gray or light blue-gray. That is, on emerging, one ray is retarded $\frac{1}{4} \lambda$ behind the other. Mica is monoclinic with the acute bisectrix nearly parallel to the vertical axis; the two rays emerging in such a section are γ or the slow ray and β or the intermediate ray. The cleavage piece is mounted with the vibration plane of γ parallel to the long edge of the slide, or the direction of the vibrations of the slow ray is marked on the slide as was the case in the quartz wedge. The mounted section slips in the slot in the tube of the microscope, between the objective and the analyzer, with its planes of vibration at 45° to those of the nicols.

Fig. 343 is a diagram of the interference figure to be tested with the $\frac{1}{4} \lambda$ mica plate inserted, with the slow ray λ vibrating parallel to the arrow and across the quadrants 1 and 3. The faster ray will vibrate across the quadrants 4 and 2 at right angles to the slow ray. Let the section under observation be one of quartz, cut perpendicular to the optic axis, an optically (+) mineral. In this case the extraordinary ray is the slow ray; its vibrations at any point in the section are directed toward the optic axis c

or the center of the diagram. In the quadrants 1 and 3 it will therefore vibrate parallel, or nearly so, in all positions to the arrow or the slow ray of the mica plate. When it emerges from the section, it will have been retarded and is vibrating in phase behind the other ray, vibrating at right angles to the arrow. In passing the mica plate the slow ray is still more retarded and the difference between the phases of the two rays is increased by $\frac{1}{4} \lambda$, that due to the mica plate. This is exactly the same as if the section was increased in thickness, in the quadrants 1 and 3, an amount sufficient to produce a difference of phase in the two rays of one quarter wave length, and all color bands in quadrants 1 and 3 will move toward the center, a distance due to one quarter wave length.

In quadrants 2 and 4, the extraordinary ray is now vibrating at right angles to the arrow, or the slow ray of the mica plate, and the two rays on emerging from the mica plate are reduced in phasal difference by one quarter wave length. The effect is exactly the same as if the section had been decreased in thick-

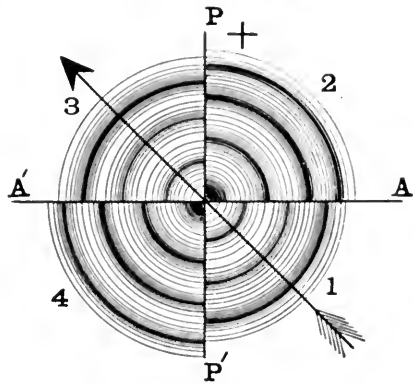

FIG. 343.

ness, in the two quadrants 2 and 4, an amount that would equal a difference of phase in the two rays of one quarter wave length. All color bands, therefore, in these two quadrants will be pushed out from the center a distance equal to a phasal difference of one quarter wave length. The interference figure will be displaced along the planes of the nicols, and the colored circles will be interrupted or carried toward the center in quadrants 1 and 2 a distance equal to one quarter wave length, and in 3 and 4 pushed out a distance equal to one quarter wave length. The displacement between two adjacent quadrants is one half wave length. In quadrants 2 and 4 the optic axis is displaced and now two dark spots appear, one in each quadrant, caused by the compensation of the section by the mica plate. In positive crystals the extraordinary ray is the slow ray, and these two dark spots will appear in the quadrants not crossed by the arrow, or a line connecting the two dark spots crosses the arrow at right angles,

i.e. makes a + sign. The crystal is then optically (+) and the extraordinary ray is the slow ray, $\epsilon > \omega$. When the two dark spots are in the quadrants crossed by the arrow, *i.e.* are on the arrow, and the line connecting them is parallel to the arrow, the crystal section is optically (-) and the extraordinary ray is the fast ray and $\omega > \epsilon$.

Circular polarization. — When the interference figure of a section of quartz of 3.5 mm. in thickness cut at 90° to the optic axis is viewed in the microscope, it will be noted that the central portion is not dark, as would be expected, but colored, and the dark cross is not continuous through the central portion of the field, Fig. 344. This is caused by a peculiar property of most crystals

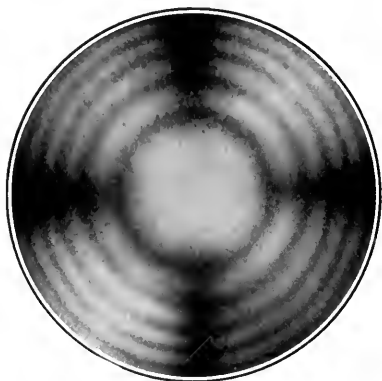

FIG. 344.— Interference Figure of Quartz.

belonging to the holoaxial types, of rotating the plane of polarized light. When the light from the polarizer enters such a section, cut at 90° to the optic axis, it is broken up into two rays circularly polarized in opposite directions and one traveling faster than the other. The two rays on emerging from the section unite to form plane polarized light, but as one ray was faster than the other the plane of the resulting plane polarized ray is not the same as that of the ray on entering the section, but it has been rotated through an angle, the size of which will depend upon the thickness of the section, the specific rotating power of the substance and the color of light used. The plane will be rotated to the right (clockwise) in right-handed crystals and to the left (anticlockwise) in left-handed crystals.

If monochromatic light is used to make this observation, in the ordinary section the central portion of the field is dark, as the light passing is still vibrating in the plane of the polarizer and is extinguished by the analyzer; but in case of quartz the central portion of the field is illuminated, as the plane of polarization has been rotated through an angle and the analyzer no longer extinguishes it. In order to do so, the analyzer must be rotated through the same angle, clockwise in right-handed crystals and anticlockwise in left-handed crystals, through an angle, other things being

equal, depending upon the wave length or color of the light. In the case of white light a right-handed crystal, when the analyzer is rotated clockwise, and to the right, the central portion of the field passes from red to orange, yellow, green, blue, violet, or will go down the scale of colors. In a left-handed section, this order of colors is yielded by a rotation of the analyzer to the left or anticlockwise.

When a right-handed section is superimposed on a left-handed section, a very peculiar interference figure is yielded, Fig. 345, known as Airy's spirals. These spirals are often



FIG. 345.—Airy's Spirals.

yielded by sections of natural crystals, and are due to the twinning of right- and left-handed forms. The rotating power of a crystal decreases as the inclination of the section to the optic axis increases, until in a parallel position it is nil.

The indicatrix of biaxial crystals is an ellipsoid, but not an ellipsoid of revolution. The two rays are both variable rays, except in the planes of symmetry. It is in these three planes of symmetry that one ray is an ordinary ray or has a constant index of refraction and the wave front would be a circle, that of the other an ellipse. Figure 346 is a diagram of the indicatrix constructed with its three axes proportional to the three indices of refraction, $OX = \alpha$, $OY = \beta$,

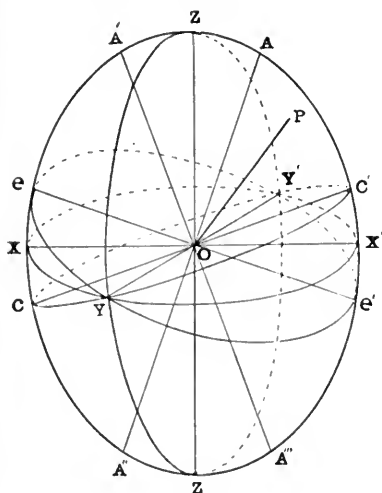

FIG. 346.

$OZ = \gamma$. Then a ray passing through the crystal in the direction of OY will be divided into two rays, one vibrating in OY with an index of refraction OY ; the other variable, and its index

of refraction will lie between α and γ as limiting values. Similarly along the two directions OX and OZ .

In general all plane sections of the indicatrix passing through O are ellipses, except in two directions when they are circular. Light passing perpendicular to all elliptical sections, as at any point p in the direction pO , will be transmitted as two plane polarized rays vibrating in planes at 90° to each other, the traces of which are the major and minor diameters of the elliptical section of the indicatrix, cut by the plane at 90° to the direction of the entering ray. The extremities of these two diameters are the conjugate points, from which normals to the surface determine the velocity, the direction of transmission, and vibration planes of the two rays. The major and minor diameters of the elliptical section perpendicular to the direction of the ray are the traces of the planes of vibrations of the resulting rays in the crystal. These two diameters always bisect the angle included between the traces on the same plane, of the planes containing the ray and the optic axes, as the two planes pOA and POA' . The directions AA'' and $A'A'''$ are the optic axes, and sections of the indicatrix at right angles to these two directions are circular, as $yey'e'$ and $ycy'c'$, and there is no double refraction, as there is no definite plane of vibration, as many or all planes are possible; and light is transmitted along $A'A'''$ and AA'' without polarization or double refraction. Each section of a biaxial crystal, not perpendicular to an optic axis, will transmit two rays vibrating in planes and polarized in planes at 90° , and when the section is revolved on the stage between cross nicols, light will be extinguished four times in 360° , as in uniaxial crystals.

In the orthorhombic system, where the planes of symmetry of the indicatrix are parallel to the crystallographical axes, the pinacoidal zones will show straight or parallel extinction; any other section will show symmetrical extinction as in uniaxial crystals. There are three possible positions for the plane of the optic axes, parallel to each of the three pinacoids in turn. In the monoclinic system, where one plane of symmetry of the indicatrix must coincide with the plane of symmetry of the system, one axis of the indicatrix will be fixed parallel to the orthoaxis of the crystal. There will be parallel extinction in one zone only, that in which the orthoaxis is the zonal axis. In all other directions there will be an extinction angle, reaching a maximum in the plane of symmetry.

In the monoclinic system, the extinction angles in particular zones or on fixed planes are characteristic, particularly that of the

plane of symmetry; and these angles are of great service in the identification of mineral species in rock sections.

The plane of the optic axis when parallel to the plane of symmetry of the system is fixed, but the acute bisectrix may revolve in that plane around the orthoaxis, and the angle it makes with the vertical axis \hat{c} is the measure of the angle of extinction in the plane of symmetry and is characteristic of mineral species, but varies with the composition of the specimen. Fig. 347 is a diagram of the plane of symmetry of the amphiboles representing the extinction angles of the common varieties. The angle is measured in the clinopinacoidal section in reference to the crystalline outline or the prismatic and orthopinacoidal cleavage cracks. Again the acute bisectrix may be the orthoaxis, at right angles to the plane of symmetry, when the plane of the optic axis may revolve around the acute bisectrix as an axis; in this case the extinction angle is measured from the obtuse bisectrix, which will lie in the plane of symmetry.

In the triclinic system, any plane may be the plane of the optic axes, and there is no relation between the indicatrix or optical symmetry and the crystallographical axes, except in individual species, where the angles of extinction are usually given in reference to some well-marked cleavage plane, or the acute bisectrix is oriented by giving the angles it forms with the normals of common crystal faces of the species.

In measuring the angle of extinction, at times it is quite impossible to determine exactly the point at which there is no double refraction or the least illumination. To the unaided eye this area may seem to extend over several degrees. At such times a sensitive plate is used, one by means of which the slightest double refraction may be detected. This sensitive plate is made from a cleavage piece of selenite, of such a thickness that, when mounted and slipped in the tube of the microscope in the same position as the quartz wedge, with its vibration planes at 45° to those of the nicols, will illuminate the field of the microscope evenly with

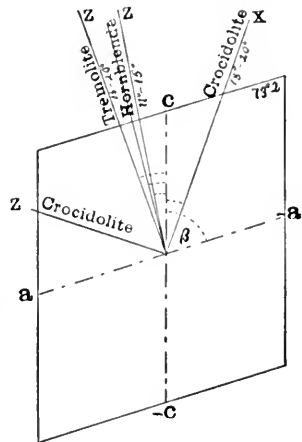

FIG. 347.—Diagram of the Extinction Angles of the Amphibole.

a red of the first order. In measuring the angle of extinction the crystal section is revolved until this even tone of red is not affected, when there will be no double refraction due to the section and the vibration planes of the section will be parallel to the planes of the nicols, and the section will be in the position of extinction. If there is the slightest double refraction, the red of the first order will change to blue or yellow, or the tone of red will be changed as the case may be, and the vibration planes of the section will not be exactly parallel to those of the nicols.

Interference figures in biaxial crystals.—Let Fig. 348 represent a section SS' cut perpendicular to the acute bisectrix, in which OC_1

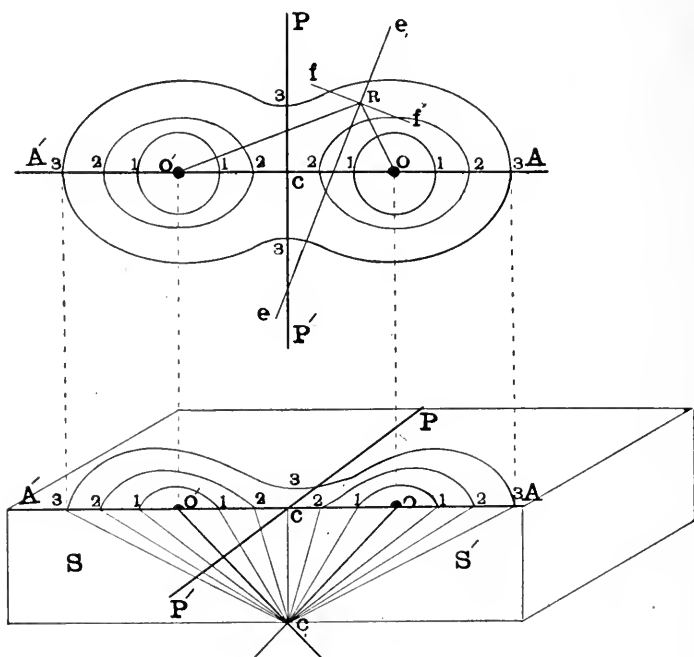

FIG. 348.

and $O'C_1$ are the two optic axes. Here also, as in uniaxial crystals, light transmitted in these directions is not doubly refracted, and leaves the section vibrating in the same plane as it did on entering that of PP' , the vibration plane of the polarizer, and therefore when viewed with the analyzer in position, the two points O and O' marking the position of the optic axes in the section will be dark. If the section is cut exactly perpendicular to the acute bisectrix the

two optic axes will emerge an equal distance on either side of the axis of the microscope, and the interference figure as a whole will lie symmetrically placed in the field of the microscope. The line drawn through the two points O and O' will be the trace of the plane of the optic axes on the plane of the section.

The optic axes will be the axes of cones of rays which pass through the section; the inclination or path of each will vary with the distance OO' . At some distance from O and O' , depending upon the double refraction and thickness of the section and the inclination of the ray, there will emerge two rays with a phasal difference of a whole wave length. These

two rays will be made to vibrate in the same plane in passing the analyzer and will interfere. The point where one ray is retarded behind the other one wave length will appear dark if monochromatic light is used, as the analyzer adds a phasal

difference of $\frac{1}{2}\lambda$. As the section of this cone of rays, in the plane of the mineral section, is ellipse-like, elliptical shadows or dark areas will appear around each optic axis as indicated. Alternating concentric areas of light and darkness will appear as indicated in the diagram, according to the phasal difference of the emerging rays. When

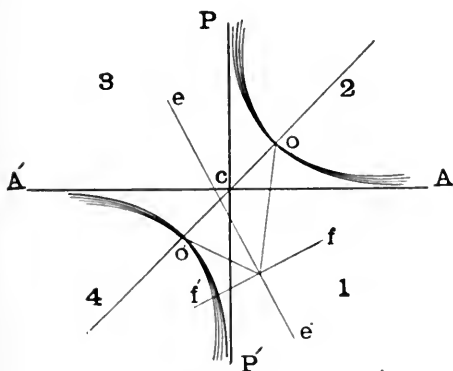

FIG. 350.

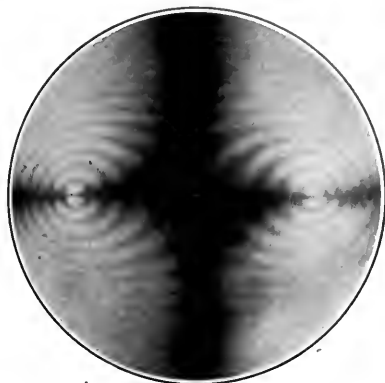

FIG. 349.—Interference Figure of Aragonite with the Plane of the Optic Axes Parallel to the Plane of one of the Nicols.

white light is used, the concentric areas will be colored as in the interference figure of uniaxial crystals. In order to determine what portion of the field will be dark in crossed nicols, due to the light extinguished by the nicols, it is necessary to determine the

direction of the vibration planes of the two rays emerging at any particular point. In the plan or upper part of the diagram,

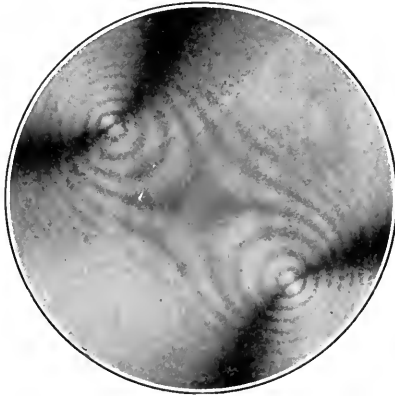

FIG. 351.—Interference Figure of Aragonite with the Plane of the Optic Axes at 45° with the Planes of the Nicols.

let any point whatever, as **R**, be taken, there will be two rays emerge, vibrating in planes at right angles. If from the point **R** the lines **RO** and **RO'** be drawn, they will be the traces on the plane of the section of the planes containing the ray **R** and the optic axes **O** and **O'**. The angle **ORO'** is bisected by the trace of the vibration planes on the plane of the section, of one ray emerging at **R**, that of the extraordinary ray, as **ee₁**; the vibration plane of the other ray will be at right angles to this plane, as **ff'**. The two rays emerging at **R**, one vibrates parallel to **ee'**, the other parallel to **ff'**, both have components parallel to **PP'** and **AA'**, the vibration planes of the nicols, and the point **R** in the field will be illuminated. When all points in the field are tested, it will be found that when the plane of the optic axis is parallel to either vibration plane of the nicols, the dark area will be in the form of a cross, as represented in the photograph, Fig. 349. Let the stage of the microscope with the section be revolved 45° as in the diagram, Fig. 350. **O**, **O'** are the optic axes and **OO'** is the trace of plane of the optic axes, now at 45° to the planes of the nicols.

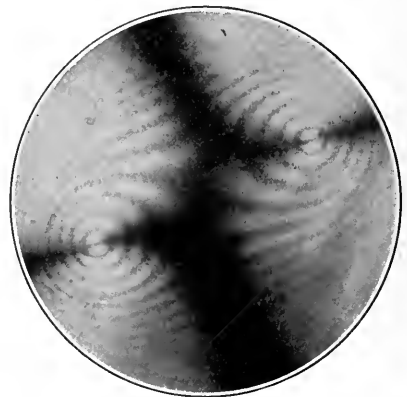

FIG. 352.—Interference Figure of Aragonite with the Plane of the Optic Axes revolved slightly out of the Parallel Position, showing the Formation of the Hyperbola.

The dark areas in this position will be quite different from that illustrated in Fig. 349. If any point **R** be taken as before, and the vibration

planes of the two emerging rays found as before, ff' and ee' will both have components in the direction of the vibration planes of the nicols, and the point R , dark before, will now be illuminated. In the same way, if all points in the field are tested and the dark areas plotted, the dark areas would have the form of hyperbolas, as shown in the photograph, Fig. 351, with the optic axes at the poles and the plane of the optic axes bisecting the curved shadow. The acute bisectrix is located on the convex side of the curved shadow midway between the two.

The movement of these shadows should be carefully observed on revolving the section, as their paths and curves help, very materially, to locate the acute bisectrix and the direction of the plane of the optic axes when but a small portion of the interference figure is within the



FIG. 353. — Interference Figure of Topaz.

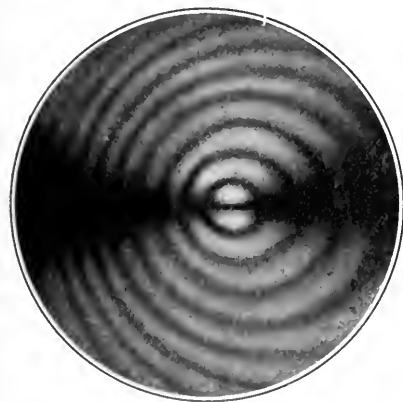

FIG. 354. — Interference Figure of Barite, section nearly perpendicular to the Optic Axis.

interference figure will still be symmetrical, as illustrated in Fig. 353.

When the section is cut perpendicular to an optic axis, the curve or color areas are circles around the optic axis, as in uniaxial crys-

field of the microscope or when the section is inclined to the acute bisectrix, causing the figure to lie eccentric in the field of view. Fig. 352 is a photograph of the interference figure of aragonite, revolved just a little, showing how the cross breaks up into the two hyperbolas. Often the angle between the optic axes is so large that the optic axes emerge out of the field of the microscope; but when the section is perpendicular to the acute bisectrix, the

tals, or possibly a little elongated at the margin, as indicated in Fig. 354, in the direction of the other optic axis. On revolving such a section the curved shadow revolves around the optic axis as a center, counter to the revolution of the section and always with its convex side toward the other optic axis. The trace of the plane of the optic axis will pass through the pole of the curve or the optic axis, bisecting the shadow symmetrically.

The optical sign of biaxial crystals. — The positive or negative character of a crystal may be determined from its interference figure. The section is placed between crossed nicols, with the plane of the

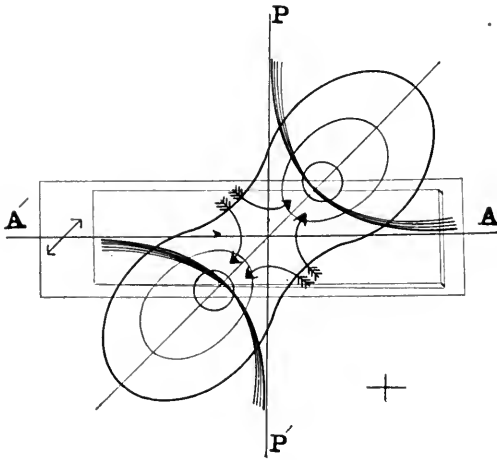

FIG. 355.

optic axis at 45° to the vibration planes of the nicols; the quartz wedge is then inserted, with the vibration plane of the slow ray of the wedge parallel to the axial plane of the section, as indicated in the diagram, Fig. 355. When the slow ray of the section vibrates in a plane parallel to the slow ray of the wedge, the circles around the optic axis

will contract from the center of the figure as they disappear at the optic axes. Other color bands will contract along the long axis of the wedge, until they meet at the acute bisectrix, when they break, forming two circles, one around each optic axis; all the color bands will continue to contract in this manner as the wedge is advanced. The direction of this contraction is indicated by the arrows in the diagram. The effect is that of thickening the section, and the sign of the section is the same as that of quartz, or positive (+). The heads of the arrows, indicating the direction of contraction, make a positive sign with the long axis of the wedge as usually mounted. When the motion of the color bands is the reverse, or they expand from the optic axes, the section has been thinned by the advance of the wedge, and the section is the reverse of that of the quartz, or

negative (-). The arrows in the diagram are reversed. Care should always be taken that the same relative positions of the wedge and the axial plane exist; for if the slow ray of the wedge is introduced at right angles to the plane of the optic axes, all motions of the color bands are reversed and the sign may be taken opposite to what it really is. Also in sections of negative crystals after the point of compensation has been reached and the wedge is still advanced, the effect is as if thickening the section, or a positive crystal.

Measurement of the angle between the optic axes. I. — The approximate value of $2E$ may be obtained by measuring the distance between the two poles of the hyperbolas in the interference figure of a section perpendicular to the acute bisectrix and in the 45° position with a micrometer eyepiece. Placing this value at $2d$, then $\sin E = d/C$, where C is a constant for the combination of lenses used, and may be determined by a section in which the angle between the optic axes is known, as aragonite.

II. — After the three indices of refraction have been determined, the angle $2V$ may be calculated from the formula,

$$\cos V = \sqrt{\frac{\frac{1}{\beta^2} - \frac{1}{\alpha^2}}{\frac{1}{\alpha^2} - \frac{1}{\gamma^2}}}$$

As the value of $2V$ is influenced considerably by variations in the fourth decimal place of the value of the indices of refraction, this method is not as accurate as the direct determinations of the angle.

III. — In the direct determination a section of the crystal is required, cut perpendicular to the acute bisectrix. The section is mounted in the axial angle goniometer, with the plane of the optic axis at 45° to the vibration planes of the nicols. One hyperbola is brought tangent to the hair of the eyepiece and a reading taken; then the second hyperbola is brought tangent to the hair and a second reading taken; the difference between the two readings is the value of $2E$, the axial angle measured in air; $2V$, the true axial angle, may be calculated when the median index of refraction β is known,

$$\beta = \frac{\sin i}{\sin r} = \frac{\sin E}{\sin V}, \text{ or } \sin V = \frac{\sin E}{\beta}, \text{ Fig 356.}$$

$2E$ is always greater than $2V$; and when $2V$ is large, the ray along the optic axes is often totally reflected at the surface of the section,

and the angle in air would be 180° . It is then necessary to immerse the section in a strongly refracting liquid, which decreases the apparent angle. $2H$ is the term used when measured in a strongly refracting liquid, as oil or any of those liquids given under the determination of the index of refraction, page 215. Then $\sin V = \frac{n}{\beta} \sin H$, where n is the index of refraction of the liquid in which the section is immersed.

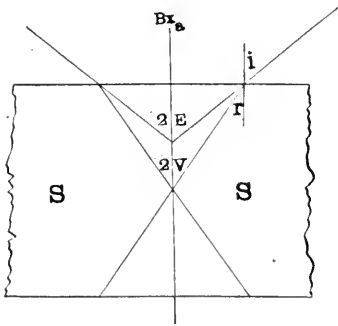

FIG. 356.

Dispersion of the optic axes.— When light of different wave lengths is used in the measurement of the axial angle, the value will differ with different colors and change progressively from one end of the spectrum to the other. This change

of the axial angle for light of different wave lengths is termed the dispersion of the optic axes, Fig. 357. Whether the angle is greater for red light, ρ , than for violet light, v , or the reverse, will depend upon the relative values of the three indices of refraction for these individual wave lengths. When the angle is greater for violet light than for red, it is expressed $v > \rho$, and the reverse, $\rho > v$.

This can usually be determined by a close inspection of the interference figure yielded by white light. If the angles for all colors were the same, *i.e.* no dispersion of the optic axes, the hyperbolas for each color would lie in the same position and those for all colors would be superimposed; but when they differ for different wave lengths,

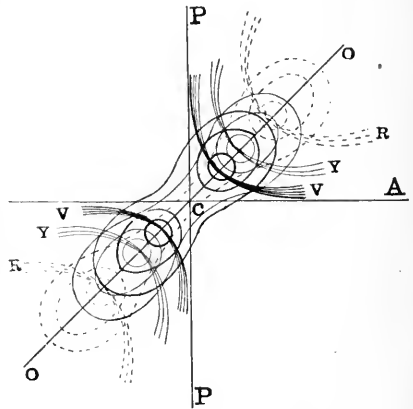

FIG. 357.—Dispersion of the Optic Axes.

as when that for red is greater than that for violet, the hyperbola for red is farther away from the acute bisectrix than that for violet; and when white light is used, the red wave will be

suppressed along the concave side of the hyperbolas, the side farthest away from the acute bisectrix, and the color appearing will be white light minus red, or blue. On the convex side of the hyperbolas will be white light minus violet, or red.

The convex side is red when $\rho > \nu$, and the convex side is blue when $\nu > \rho$. In the orthorhombic system the dispersion of the optic axes takes place in one of the planes of symmetry of the crystal, and the acute bisectrix holds the same position for light of all colors, except when $2E$ is nearly 90° . $2E$ for red may be less than 90° with the vertical axis c the acute bisectrix, and greater than 90° for violet when one of the lateral axes would be the acute bisectrix for the violet wave. Again the plane of the optic axis may change from one pinacoidal plane to another with the wave length, as is the case in brookite, in which the plane of the optic axes for waves including red to yellow is parallel to the base, with the brachyaxis as the acute bisectrix; for waves shorter than yellow the plane of the optic axis is parallel to $o1o$, or macro-pinacoid, with the brachyaxis still the acute bisectrix. In such a case the plane of the optic axis is said to be crossed, or the dispersion is crossed, and there must be a wave length of light a little shorter than yellow for which the angle between the optic axes is 90° , or for which the mineral brookite would be uniaxial.

Dispersion in the monoclinic system.— In the monoclinic system, where but one of the axes of the indicatrix is fixed in relation to the crystallographical axes, that in the direction of the orthoaxis, **three kinds** of dispersion are possible, as the three axes of the indicatrix, α , β ,

γ , each in turn may be parallel to the orthoaxis. 1. When β is parallel to the orthoaxis, the plane of the optic axes will lie in the plane of symmetry of the crystal and will be fixed at 90° to the orthoaxis, but may revolve around it as an axis.

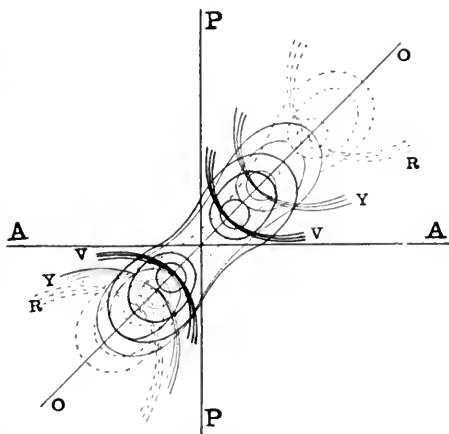

FIG. 358.—Inclined Dispersion of the Optic Axes.

It is not necessary that the angle between the acute bisectrix and the vertical axis should be constant, and it is constant only for individual species when chemically pure. The value of this angle will change with the composition of the mineral, and with the wave length of light for the same composition. In common hornblende this angle is $19^{\circ} 53'$ in the obtuse angle β . Expressed, $Bx_{\alpha} \wedge C = 19^{\circ} 53'$ in front; this is also a measure of the extinction angle, which is inclined. If monochromatic light of different wave lengths is used, it will be found that this angle will vary with the color of light used. The interference figure as a whole is displaced, and that of one color will not be superimposed on that of another, yet the trace of the plane of the optic axes

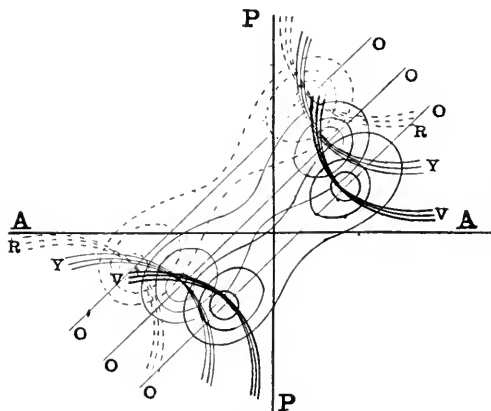

FIG. 359. — Horizontal Dispersion.

will divide them all symmetrically. This is termed **inclined dispersion**, Fig. 358.

2. When the orthoaxis is the obtuse bisectrix, the plane of the optic axis may rotate around it as an axis of revolution; and the interference figure for each wave length of light which is in the section perpendicular to the acute bisectrix may be displaced sidewise through an arc measured in the plane of symmetry. The trace of the plane of the optic axes will also be displaced through this same angle for each wave length. The traces of the planes for each color will lie parallel on the section, but the planes will all intersect in the obtuse bisectrix or orthoaxis, which is fixed, Fig. 359. This is termed **horizontal dispersion**.

3. When the acute bisectrix coincides with the orthoaxis. Now the interference figure will lie in the clinopinacoidal section, and will revolve around the acute bisectrix as a center. The traces of the plane of the optic axes for light of the various colors will all pass through the fixed point, the center or acute bisectrix, Fig. 360. This is termed **crossed dispersion**.

Dispersion in the triclinic system.—In the triclinic system,

where there is no fixed direction to which any of the axes of the indicatrix must conform, it is possible for all varieties of dispersion described in the other systems to take place at one and the same time, and the interference figure may be entirely without symmetry.

Methods of determining the indices of refraction. —

The index of refraction of any substance is a physical constant, characteristic of the substance. It not only serves as a means of identification, but also as a measure of purity. The value of the index of refraction varies with the temperature, but this variation in case of solids, at ordinary temperatures, is small and within the limits of error, therefore negligible.

The index of refraction, when all precautions and when great care are taken, together with an average of several observations, may be determined within .0002.

The value of the index of refraction for minerals will lie between

1.3, that of ice, and 3.08, that of pyrrargyrite.

I. The most accurate method is that in which the angle of deviation of the refracted ray is actually measured, as transmitted through a prism of 60° , or one not varying more

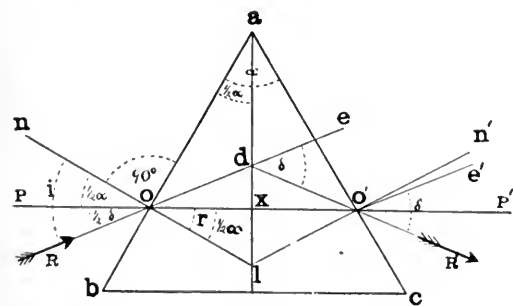

FIG. 361.

than 5° from 60° . As the angle of deviation will vary with the inclination of the ray, the angle of least deviation is found and measured as follows.

In Fig. 361 *abc* is the prism, with the angle at *a* nearly 60° . This angle is accurately measured with the goniometer. The ray of

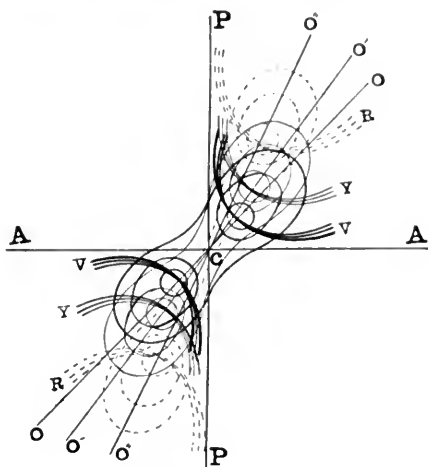

FIG. 360. — Crossed Dispersion.

light RO enters at O , is refracted to O' , and is again transmitted, on leaving the prism, in the direction of $O'R'$. The angle of deviation due to the prism is $R'de = R'O'e' = \delta$. This will be at a minimum, or is the least deviated, when the ray passes through the prism symmetrically as drawn in the figure.

$n = \frac{\sin i}{\sin r}$; $i = RO_n$. The angle $bac = \alpha$; $dab = 1/2 \alpha$ and $axO = 90^\circ$.

$aOl = lO'a = 90^\circ$. $\therefore xOl = xaO = nOP = 1/2 \alpha = r$, the angle of refraction.

Draw $O'e'$ parallel to Re , then from the symmetry of the figure the angle $e'O'R' = R'de = \delta = e'O'P + P'O'R'$, $POR = dOx = e'O'P'$; also $dox = P'O'R' = POR = 1/2 \delta$, but $NOP = xOl = 1/2 \alpha$.

$i = NOR = 1/2 \alpha + 1/2 \delta$ and $n = \frac{\sin i}{\sin r} = \frac{\sin 1/2 (\alpha + \delta)}{\sin 1/2 \alpha}$, where

the angle α is carefully measured with the goniometer.

The angle of least deviation is found as follows: The telescope of the goniometer is set exactly opposite the collimator and the direct ray through the Websky slit is observed and adjusted to the cross hairs, when a reading is taken with everything clamped.

The graduated circle and telescope remaining clamped, the crystal is mounted and adjusted so that the edge at the angle α is parallel to the vertical hair. It is then pushed in with the screw, between the collimator and the telescope, until the image of the slit disappears on looking in the telescope, the base of the prism being to the left. With the graduated circle still clamped, the telescope is now unclamped and revolved to the left until the image or signal reappears, then the prism is revolved back and forth through a small arc, at the same time following the signal with the vertical hair of the telescope. It will soon be seen that on revolving the prism there is a maximum position to the right for the signal, and having reached this position, even though the prism is still revolved the same way, the signal moves up to this position then reverses its motion or turns back. This maximum position marks the point where the ray is symmetrical to the prism as drawn in the diagram, Fig. 361. By moving both the telescope and prism at the same time, the vertical hair is brought to this maximum position of the signal and a reading taken. The difference between the original position of the signal and this of the least deviation will be the angle δ . When white light is used, there will be a series of colored signals, one for each color, due to dispersion, but only one

image when monochromatic light is used. Having measured the angle of least deviation, the index of refraction is obtained from the formula above. In all isotropic substances n will be of the same value, whatever the relation of the edge of the prism to the crystal may be. This is not the case in anisotropic substances, where the prism edge must be cut with a definite relation to the axes of the indicatrix.

In the tetragonal and hexagonal systems, the edge of the prism containing the angle α should be cut parallel to the base, and the plane bisecting the angle parallel to the vertical axis, or the prism edge containing α may be cut parallel to the vertical axis. In either case, in measuring the angle of least deviation, two signals will appear, one caused by the ordinary ray, the other by the extraordinary ray. These two readings substituted in the formula will yield two indices of refraction, one that of the ordinary ray ω , the other that of the extraordinary ray ϵ .

In biaxial crystals, where there are three indices of refraction to be determined, two prisms are necessary. One must be cut with the edge containing the angle α parallel to an axis of the indicatrix, and the plane of symmetry of the indicatrix containing this edge of the prism must also bisect the angle α . The second prism must be cut in the same relation to a second axis and plane of the indicatrix. Each of these prisms will yield two signals as in the uniaxial prism and therefore two indices of refraction. One prism will yield α and β , the other β and γ . The index repeated or determined in both prisms will depend upon the axes of the indicatrix to which the edges of the prisms are parallel.

II. **Method of total reflection.** — Fig. 362 is a diagrammatic section of the Abbe Total Reflectometer, in which C is a hemisphere of Jena flint glass, having an index of refraction $n = 1.8904$, the upper surface of which, b , is polished to a true plane passing through the center of the sphere and adjusted so as to pass through the axis of the vertical graduated circle from which the readings are taken and which is not represented in the diagram. A polished section S is cut parallel to a plane of symmetry of the indicatrix. Often a cleavage surface will fill this requirement. A small drop of a highly refracting liquid, usually methylene iodide, $n = 1.742$, having first been placed on the center of the plane b , then the polished face of the section S is placed gently on the hemisphere with a thin film of the highly refracting liquid separating the two surfaces. M is a mirror which reflects light in the required direction.

The limiting ray tO , striking the surface of the section at O , is totally reflected in the direction Ot' . The angle $t'Oe$ is the critical angle. Any ray, as mO , within this angle will at the point O be re-

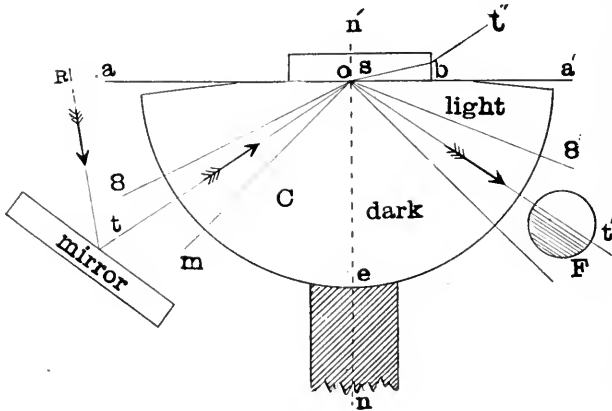

FIG. 362.

fracted and pass out in the direction Ot'' , and some will be reflected within the angle $t'Oe$, and the field $t'Oe$ will be semi-illuminated.

Any ray, as $8O$, striking the plane surface s at an angle greater than the critical angle eOt' , will be totally reflected in the direction of $O8'$ and the field $a'Ot'$ will be fully illuminated. At the boundary between these two fields, $t'O$ will be marked by a shadow. The field of the telescope, represented by the circle F , is brought with the cross hairs to the shadow, and

a reading which gives the critical angle eOt' is taken. Then $n = N \sin r$, where N is the index of refraction of the glass hemisphere and r is the critical angle.

This method has the advantage of the possibility of determining all three indices of refraction in one and the same section. As

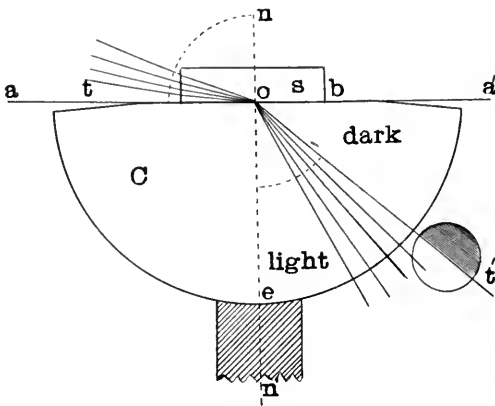

FIG. 363.

one ray is constant, the shadow caused by it will not change on completely rotating the hemisphere with the section. The other ray will increase from a minimum to a maximum according to the position of the section; and these two limiting values will represent the critical angles for the other two indices of refraction. The telescope is fitted with a nicol so that light vibrating only in the plane required may pass and illuminate the field.

The ray may also be adjusted to enter the section as represented in Fig. 363, and the field $a'Ot'$ will be entirely dark, and the field $t'Oe$ will be illuminated and the contrast between the two fields will be greater.

III. A convenient refractometer, as constructed by Herbert Smith of the British Museum and illustrated in Fig. 364, is so ar-

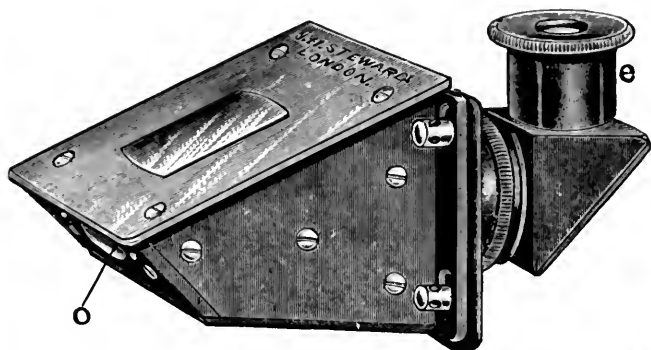

FIG. 364. — Refractometer.

ranged that the index of refraction may be read directly from a scale in the instrument to the second decimal place and the third estimated. The specimen is placed on the highly refracting glass with a film of liquid between, as in the Abbe instrument. The light entering at O , the shadow is thrown on the scale and the reading taken. In double refracting substances two shadows will be noted, indicating the two indices of refraction; the section is revolved until these are maximum or minimum values. This instrument is very convenient for jewelers in the determination of the refraction and identification of cut stones.

IV. Cleavage pieces of transparent minerals may be used to determine the index of refraction with the microscope. The thickness of the section S , Fig. 365, is measured with a micrometer cali-

pers = T . A slide with a fine scratch is placed on the stage and the microscope very carefully focused on the scratch o . Then the mineral section is placed over the scratch. The scratch will now not be in focus, but will again come in focus by turning the fine adjustment of the microscope, so as to lift the objective; o will appear as if at o' ; the distance oo' which the scratch seems to have been lifted will depend upon the thickness of the section and the index of refraction of the mineral. The apparent thickness of

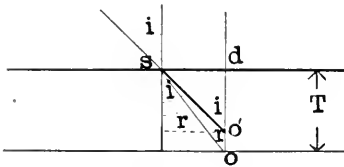

FIG. 365.

of the section do' is determined by measuring the distance oo' with the micrometer of the microscope, and subtracting oo' from T .

Then, $n = \frac{T}{T - oo'}$ or $\frac{\text{The actual thickness}}{\text{The apparent thickness}}$, for $n = \frac{\sin i}{\sin r} = \frac{\tan i}{\tan r} = \frac{T}{T - oo'}$, as for these small angles the ratio of the tangents is practically the same as that of the sines. This method is only an approximate one and thick sections must be used. Ordinary rock sections are too thin for accuracy.

V. A convenient method of determining the index of refraction of minerals in powder or very small crystals is to mount them on a slide in fluids of different indices of refraction. A list of such fluids

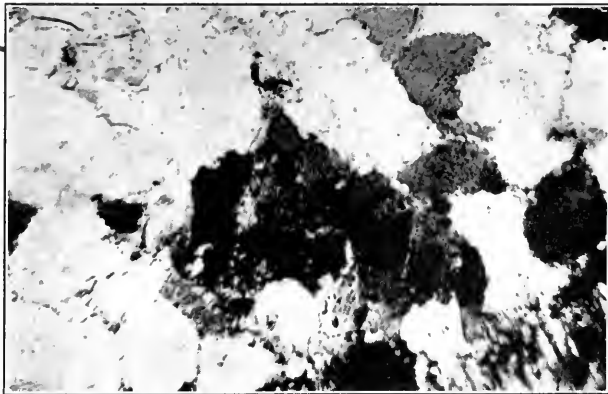

FIG. 366. — Section of a Quartzite, showing the Low Relief. Crossed Nicols.

which cover the range of the indices of refraction of most important rock-forming minerals, as given by F. E. Wright, are :

- 1.450-1.475 . . Mixtures of petroleum and turpentine.
 1.480-1.535 . . Turpentine and ethylene bromide.
 1.540-1.635 . . Clove oil and α -monobromnaphthalene and
 α -monochloronaphthalene.
 1.660-1.740 . . α -monobromnaphthalene and methylene iodide.
 1.745-1.790 . . Methylene iodide and sulphur.

When the index of refraction of the crystal fragments are the same as the fluid in which they are mounted, the outlines of the fragments are very indistinct and scarcely visible. This is well illustrated by the glass rod in the Canada balsam bottle, the indices of which are nearly the same, and the rod is scarcely visible. Quartz mounted in balsam is also indistinct, as the indices $\omega = 1.544$ and $\epsilon = 1.553$, while for balsam $n = 1.548$, just between. In a section

of quartzite where the grains are all the same color, their outlines will be invisible in ordinary light; but in crossed nicols, where they will be differently illuminated, they are quite distinct, Fig. 366. The outlines of mineral fragments are more marked or distinct, the greater the difference of refraction of the two substances. In calcite, where $\epsilon = 1.486$ and $\omega =$

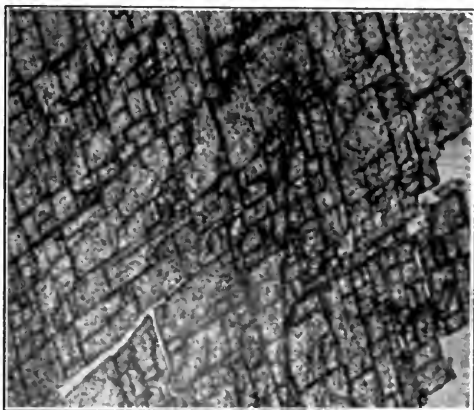

FIG. 367.—Section of Calcite showing Marked Relief and Rhombohedral Cleavage.

1.658, mounted in balsam the outlines are distinct and the surface of the section is rough, Fig. 367. It is said to have a marked or high relief. With the polarizer only in, if the section is revolved through 90° , the relief for the two rays will be noted to be quite different, as the difference in one case is .11 and in the other .062. The relief then is a measure of the difference of the index of refraction of the mineral and the index of refraction of the medium in which the section is mounted.

VI. **Becke's method**, or the determination of the relative values of the indices of refraction of two adjacent minerals in the same section. Where the index of refraction of one is known, that

of the other may be approximately estimated. This method depends upon the principle that light passing from a rarer medium or one with a lower index of refraction to one with a higher index of refraction will pass at all angles and there will be no critical angle; but in the reverse direction there will be a critical angle and some of the light is reflected to the side of the higher index of refraction. The illumination on the side of the higher index of refraction will be brighter, as some of the rays are totally reflected to that side.

As an example the index of refraction of quartz and orthoclase in a section of granite may be tested in this way. The effect is best seen with a medium high objective and with a converging light, the light being diaphragmed off so as to illuminate only a small area. If the microscope is carefully focused on the boundary between the two minerals, then the objective slowly lifted, a line of light parallel to the line of contact will appear to move in the direction of the mineral with the higher index of refraction, or on the side of quartz; the difference in this case on the average is .02. With careful work and experience a difference of .001 may be detected by this method.

Study of minerals in rock sections.— In the study of a mineral section or of minerals in rock sections, an order of observation should always be followed. The section should be carefully studied in all parts with the low power adjective in order to determine the relative abundance of each mineral species, their relations and relative size, and favorable sections should be chosen for the optical observations, then the following order should be followed:

1. **Color.**— When the mineral is opaque, it is observed in reflected light, with the mirror under the stage turned off. Minerals which are opaque in thin sections are of metallic luster, as magnetite, pyrite, pyrrhotite, or chromite. Transparent sections are observed in transmitted light and the color noted; whether evenly colored or irregular, caused by a difference in chemical composition or due to inclusions, cavities, etc.

2. **Form.**— The outline of each individual species is noted if bounded by straight lines, *i.e.* crystal faces well developed, the individuals being euhedral or idiomorphic, in contrast to those irregular in outline, which have no well-defined crystal faces developed and are anhedral or allotriomorphic; such irregular individuals usually act as a matrix, filling the cavities between the minerals of earlier crystallization, which are often of larger size, with distinct outlines or **phenocrysts**.

3. **Cleavage cracks, partings, and fractures** due to pressure or strain should be noted and the angles between two well-defined cleavage directions, where they occur, measured in a number of sections, in order to obtain the true angle or that measured at 90° to the intersection of the two cleavage planes.

4. Note the crystal outlines where well developed and where elongated; the direction of the elongation in regard to the crystallographic axes is determined, also any irregularity of the outline, as that due to corrosion, resolution, alteration, or weathering, and whether these changes are restricted to the surface or have followed cleavage cracks and fractures; also the nature of the alteration product is noted.

5. **Index of refraction.**—Rock sections are usually mounted in Canada balsam, the index of refraction of which is approximately 1.539, but varies slightly with the amount of solvent it contains or with the age of the mounted section, as the balsam is constantly hardening with age. Specimens with an index of refraction near that of balsam will have little or no relief; their surfaces will appear flat and smooth. It is well to have several mineral sections mounted for comparison, the index of each being known; their relief may be compared with the unknown section and the index of refraction approximately determined. Sodalite, 1.483; leucite, 1.508; orthoclase, 1.523; quartz, 1.547; beryl, 1.584; olivine, 1.670; and rutile, 1.712,—are good minerals for comparison. A specimen with an index of refraction above 1.60 or below 1.50 will have a rather high relief. The cracks, as cleavage, scratches on the surface made in grinding the section, and the outline,—all will appear well marked and distinct. Whether the refraction is above or below 1.549, that of balsam, can be determined by Becke's method. Minerals with a high relief seem particularly rough when the section is shaded from reflected light by passing the hand up and down in front of the microscope.

6. **In crossed nicols and parallel light.**—If the section remains dark between crossed nicols when the stage is revolved, it is either amorphous, as glass, isometric, or a double refracting mineral cut perpendicular to an optic axis. An anisotropic section between crossed nicols will yield an interference color which will be a measure of its double refraction and the section will extinguish every 90° , that is, each time the vibration planes of the section are parallel to the cross hairs of the eyepiece.

7. The angle of extinction is measured in reference to the vertical

axis, as determined in the section by the cleavage, outline, or elongation. Whether it is parallel or inclined is noted and the angle of extinction measured, also the twinning of the section may be seen in relation to the extinction angles.

8. **Pleochroism.** — This is caused by the light being absorbed along one plane of vibration in the section differently from that along the other. The section is turned on the microscopic stage until extinction, when the vibration planes of the section will be parallel to those of the nicols. The analyzer is pushed out of the line of view, when the section will be illuminated by the rays vibrating parallel to the one plane of vibration in the section only, that of the polarizer, usually running from right to left. The color of the section and the degree of illumination are both noted, as is also the relief of the section; then the section is revolved on the stage 90° , when the light will be vibrating parallel to the second plane of vibration of the section, and any change in color, shade, or relief is noted.

9. **In crossed nicols and converging light.** — All sections of the mineral under observation in the specimen are carefully examined, and one selected as nearly perpendicular as possible to the optic axis, in uniaxial crystals, and to the acute bisectrix, in biaxial crystals, is chosen. The interference figure is observed and the uniaxial or biaxial character of the crystal noted, as well as the approximate axial angle in the latter.

10. When uniaxial, the optic sign is determined with the mica plate; and when biaxial, with the quartz wedge. Where the interference figure is well formed, the character of the dispersion may also be noted.

PART II

CHAPTER I

THE RELATION OF MINERALS TO THE ELEMENTS

MINERALS, when considered from a chemical standpoint, are either elements in the uncombined state or are combinations of elements which have been brought together during the past ages and united by chemical forces which differ in no way from the same forces with which we have become acquainted in the laboratory. Some mineral molecules are simple combinations of a few chemical elements; and the same compounds are daily produced in the laboratory, in the simple processes of chemical analyses, as in the precipitation of calcium carbonate from a solution of a soluble calcium salt with an alkali carbonate. If this is carried out at room temperatures and the precipitate is allowed to stand, it will crystallize, forming calcite. If the same precipitation is carried out at temperatures near the boiling point of water, that is, on the water bath, and allowed to crystallize in a hot solution, the form aragonite will be produced. Here are two minerals, calcite and aragonite, one crystallizing in the hexagonal system, the other in the orthorhombic system. They are both calcium carbonate, and chemically they are identical; but physically they are different, and as in the precipitation they are formed under different conditions, they are two phases of the same chemical substance; moreover, calcium carbonate directly after a rapid precipitation is amorphous, another phase, and becomes crystalline only after standing. This property of chemical compounds, of occurring in different physical forms is known as polymorphism. Calcium carbonate is thus trimorphic. It may be amorphous, it may possess the molecule of calcite, or it may possess the molecule of aragonite. Silica, SiO_2 , is said to possess six different forms or phases.

The various forms of a polymorphic substance will never under the same conditions possess the same degree of equilibrium, and one form will be more stable than the others. It is always the

tendency of one form, the less stable, to pass over to the other, the more stable form, under the fixed conditions. Calcium carbonate when quickly precipitated from solution separates as an amorphous solid, and on standing passes over to the more stable crystalline forms, calcite or aragonite, according to the temperature of the solution, as calcite is the more stable form in cold solutions and aragonite is the more stable form in hot solutions. When the change of phase proceeds in one way only, the compound is said to be *monotropic*, but if the change may go back and forth with the change of temperature, or is reversible, the compounds or phases are said to be *enantiotropic*. Such a case is represented by sulphur. Sulphur when fused and then allowed to solidify at a temperature above 96° will form monoclinic crystals, which are the stable phase between 96° and 120° , the fusing point of sulphur. Below 96° these monoclinic crystals become brittle and clouded and pass over to orthorhombic sulphur, a phase more stable than the monoclinic form at low temperatures. If the temperature is again raised above 96° , the reverse of this will take place and in time the orthorhombic sulphur will form monoclinic crystals. The orthorhombic phase is the more stable below 96° , and the monoclinic phase is the more stable above 96° . There are several other phases of sulphur, but at ordinary temperatures these are all less stable than the orthorhombic phase, and it is for this reason that all natural occurring sulphur is of the orthorhombic phase. Graphite and diamond are different phases of the same element, carbon. There are numerous other examples of dimorphism in minerals, as sphalerite and wurtzite; quartz and tridymite; smaltite and safflorite; pyrite and marcasite. Pyroxenes and amphiboles are probably dimorphous conditions or phases of the same compound, and even trimorphic cases occur, as in the three minerals rutile, anatase, and brookite, all three of which are different phases of TiO_2 .

Source of the elements. — Minerals are the source of all the elements; it has been through the chemical study and the analyses of minerals that, with few exceptions, all the elements have been discovered. Those elements which occur in nature in the uncombined state as minerals are few in number and are restricted principally to the group known as metals; as platinum and the platinum group, silver, mercury, gold, copper, lead, bismuth, iron, arsenic, and antimony. Some of these, as iron, lead, antimony, arsenic, and bismuth, are rare as native elements, though quite common enough as constituents of minerals when combined with other elements.

The non-metallic elements sulphur and carbon occur in the uncombined state in nature in considerable quantities.

Of the eighty established elements, oxygen far surpasses any other in its wide distribution, forming one fifth of the atmosphere, eight ninths of the water, and from 45 to 50 per cent. of the earth's crust. The results of careful calculations indicate that the amount of oxygen is hardly equaled by all the other elements taken together, or oxygen forms about 50 per cent. of the earth as known by man. Oxygen enters the composition of a large number of minerals as an important factor. Of the other elements there are seven, silicon, aluminium, iron, calcium, magnesium, sodium, and potassium, in their order of abundance, each of which composes at least 2 per cent. of the earth's crust, and they are universally distributed. The above eight elements compose at least 97 per cent. of the earth as known to man. Metals to which we have become accustomed, through their use in our daily life, thinking of them as common elements, as copper, lead, zinc, silver, or gold, occur only in restricted localities; and owing to their commercial value the minerals containing them have been mined, with a constant accumulation of the metal reduced. Elements such as titanium, thorium, cerium, tungsten, uranium, and molybdenum, which even the chemist, in the past, considered very rare, are at the present time becoming well known in the commercial world, from recently discovered uses to which their properties adapt them. These rare elements are important constituents of but comparatively few minerals, and these are usually restricted to localities where many of them occur associated together.

Such localities are constantly being searched for by the prospector, urged on by the constant demand and increase in price, as several of these rare elements have been proven useful in the production of special steels, in the manufacture of lighting mantles, and in incandescent lamp filaments.

At the present time salts of some rare earths are being produced by the ton as by-products, which had chemists wished to secure in pound lots only, it would a few years ago have been impossible. Of the most important elements the following list includes those which are found in the earth's crust in amounts exceeding .02 per cent.:

Oxygen	49.98	Sodium	2.28	Phosphorus	.09
Silicon	27.21	Potassium	2.23	Manganese	.07

Aluminium	7.26	Hydrogen	.94	Barium	.05
Iron	5.08	Titanium	.41	Sulphur	.04
Calcium	3.51	Carbon	.22	Nitrogen	.02
Magnesium	2.50	Chlorine	.15	Strontium	.02

Chromium, fluorine, lithium, and uranium are all less than .02 and probably greater than 0.01; bromine and all other elements are each, in turn, less than .01.

In a classification of the minerals their most important characteristics must be considered, and the starting point of a natural classification is without doubt one in which the chemical composition and physical properties are the most important consideration, though the latter to a large extent are derived from the elements a mineral contains. Those minerals which are composed largely of the same elements should stand in any scheme of classification near together, especially since mineral species are mostly determined by the chemical tests for the elements which they contain. The classification of minerals will follow closely the natural classification of the elements themselves. It has been shown, especially by Mendeleef, that the properties of the elements are determined by their atomic weights, and from a consideration of this fact a natural classification of the elements has been adopted which places the elements in the order of their atomic weights.

In a list of the elements placed in the order of their atomic weights, starting with lithium, the first element which possesses a well-developed chemical character, the atomic weight increases until sodium is reached, with an atomic weight of 23. Sodium is an element very similar to lithium in its chemical properties and very different from fluorine, with an atomic weight of 19, directly preceding it. Sodium is then written in the column with lithium and a second horizontal line or group is started.

In each case, elements having similar or related chemical properties will fall in the same column, and these properties will be repeated periodically. This whole scheme is known as the periodic classification of the elements.

Elements falling under each other in the same column of the table of elements are of the same valence and are capable of replacing each other in mineral molecules to a large extent, though this property may not extend from top to bottom of the column in all groups. In the first column or group, lithium, potassium, rubidium, and caesium fall directly under each other. These are all alkali

THE PERIODIC CLASSIFICATION OF THE ELEMENTS

	0	I	II	III	IV	V	VI	VII	VIII
		R ₂ O	R ₂ O ₂	R ₂ O ₃	R ₂ O ₄	R ₂ O ₅	R ₂ O ₆	R ₂ O ₇	R ₂ O ₈
1		Hydrogen H = 1.0077							
2	Helium He = 4	Lithium Li = 6.93	Beryllium Be = 9.1	Boron B = 11.0	Carbon C = 12.00	Nitrogen N = 14.01	Oxygen O = 16	Fluorine F = 19.0	
3	Neon	Sodium Na = 23	Magnesium Mg = 24.32	Aluminium Al = 27.1	Silicon Si = 28.3	Phosphorus P = 31.04	Sulphur S = 32.07	Chlorine Cl = 35.46	Iron, Fe = 55.5
4	Argon A = 39.89	Potassium K = 39.10	Calcium Ca = 40.07	Scandium Sc = 44.1	Titanium Ti = 48.1	Vanadium V = 51.0	Chromium Cr = 52.1	Manganese Mn = 54.93	Nickel, Ni = 58.68 Cobalt, Co = 58.97
5		Copper Cu = 63.57	Zinc Zn = 65.37	Gallium Ga = 69.9	Germanium Ge = 72.5	Arsenic As = 75.0	Selenium Se = 79.2	Bromine Br = 79.92	Ruthenium, Ru = 101.7
6	Krypton Kr = 82.92	Rubidium Rb = 85.45	Strontium Sr = 87.63	Yttrium Yt = 89	Zirconium Zr = 90.6	Columbium Cb = 93.5	Molybdenum Mo = 96		Rhodium, Rh = 102.9 Palladium, Pd = 106.7
7		Silver Ag = 107.87	Cadmium Cd = 112.4	Indium In = 114.8	Tin Sn = 119	Antimony Sb = 120.2	Tellurium Te = 127.5	Iodine I = 126.92	
8	Xenon Xe = 130.22	Cesium Cs = 132.81	Barium Ba = 137.37	Lanthanum La = 138.9	Cerium Ce = 140.25				
9									
10				Ytterbium Yb = 172		Tantalum Ta = 181.5			
11		Gold Au = 197.2	Mercury Hg = 200	Thallium Tl = 204	Lead Pb = 207.1	Bismuth Bi = 208	Tungsten W = 184		Osmium, Os = 190.9 Iridium, Ir = 194.9 Platinum, Pt = 195
12	Radium emanations Niton = 220		Radium Ra = 226.4		Thorium Th = 232.42		Uranium U = 238.5		

metals, strong bases, and only take the part of a base when combining with other metals or acids to form salts. The solubility of their salts is graded and decreases from the top to bottom, or from lithium to caesium. Similar salts crystallize in the same system and usually with the same symmetry, and with angles and elements very closely related. While the alkali metals form a very closely related group of elements, possibly more closely related than some other groups of the table, it is true, however, that those elements falling under each other in the vertical columns are very closely related in their chemical properties. In a consideration of those elements which fall in the continuous line, as from lithium to fluorine, there is a continuous gradation from the very basic, on the one hand, metals which are always found taking the part of a base in the formation of salts, to those which, on the other hand, as fluorine, are always found taking the part of an acid when forming salts. Between these two extremes there are elements which may take the part either of an acid or a base; this is particularly true of those elements, like aluminium, which are found near the middle, between the two extremes.

It has long been recognized that all salts were composed of two distinct components, the acid radicle, or acid anhydride, and the base, or oxide of the metal. This was Berzelius's conception of a salt, and the formulæ of minerals were formerly written with this conception in view, as barite, BaO, SO_3 . Here BaO is the oxide of the base, barium, and SO_3 is the oxide of the acid-forming element, sulphur. Indeed at the present time the analyses of rocks and minerals are still reported in this form as $\text{BaO} = 65.7$ and $\text{SO}_3 = 34.3$ per cent.

By the study of the behavior of salts, or more especially electrolytes, in solution and under the influence of an electric current, it has been demonstrated that salts do not break down into the two components of a basic oxide, as BaO , on the one hand, and acid oxide, as SO_3 , on the other, but they are dissociated into ions, independent components, one of which is formed by the metal $\overset{++}{\text{Ba}}$ or a complex like $\overset{+}{\text{NH}_4}$, taking the place of a metal, charged with a positive charge of electricity and traveling toward the negative pole; these are termed cations. The anion is that component which carries a negative charge, in this case $\overset{-}{\text{SO}_4}$, and travels toward the positive pole or anode. Barium sulphate thus breaks up in the two ions $\overset{++}{\text{Ba}}$ and $\overset{-}{\text{SO}_4}$.

In the classification of minerals the acid radicle has been chosen as the most important of the two components, and all minerals occurring as sulphates, or the salts of sulphuric acid, have been placed in one group.

Water in minerals. — Some minerals, especially those which are formed at a low temperature, or which separate from a water solution, contain water, or at least when heated in a closed tube they yield water. This water may be combined with the mineral molecule in various ways, as is indicated by the widely different temperatures at which it is driven off. Water which is driven off at low temperatures is considered to be loosely combined with the other elements of the molecule or with the mineral molecule. It may be directly combined with the mineral as water, though there is nothing to prove that this is actually the condition or fact.

Copper sulphate crystallizes with five molecules of water, $\text{CuSO}_4, 5 \text{H}_2\text{O}$. When this salt is heated, four of these molecules of water are driven off at 100°C ., but to drive off the fifth molecule of water and to completely dehydrate the salt the temperature must be raised to 200° . Zinc sulphate crystallizes with seven molecules of water, $\text{ZnSO}_4, 7 \text{H}_2\text{O}$, six of which are driven off at 100°C ., but the seventh will not be driven off until the temperature of 240°C . is reached. Such facts would indicate that that portion of the water contained in salts which may be driven off at low temperatures is bound up in the mineral molecule in some very simple way, and the bond is easily broken. On the other hand, some is bound up with the molecule very closely and may be dislodged, as is the case with serpentine, only at a red heat. The water which may be driven off at low temperatures is termed water of crystallization, and is usually written or indicated in the mineral formula as water; thus gypsum, $\text{CaSO}_4, 2 \text{H}_2\text{O}$, contains two molecules of water of crystallization, one of which is liberated at 120°C ., the other at 200°C . When there are several molecules of water of crystallization present in a mineral, they are not all liberated at the same temperature, but they are given off by steps or one at a time. The evolution of water on heating a crystal is discontinuous. The zeolites present an exception to this rule; in their case the evolution is continuous. Some of this water of crystallization may be so slightly bound to the chemical molecule, that it evaporates into dry air, and the crystal falls down to a powder, or whitens and is changed in appearance. Such compounds are said to be **efflorescent**. Sodium carbonate, $\text{Na}_2\text{CO}_3, 10 \text{H}_2\text{O}$, in dry air will lose

9 H₂O and form a white powder, Na₂CO₃, H₂O. In certain cases the water of crystallization when driven off may be reabsorbed from a damp air. Gypsum, CaSO₄, 2 H₂O, when heated to 130° C. loses one of the molecules of water and when powdered forms plaster of Paris; this will gradually pass back to CaSO₄, 2 H₂O by the absorption of water from a damp atmosphere, or it will take it up very quickly when mixed with water, setting into a hard mass, and at the same time evolving heat as the water is combined. This **heat of combination** will vary with the molecule of water given off and is the greatest in case of the last molecule to be liberated from a compound, or the one which is liberated at the highest temperature. The heat of combination is a measure of the bond.

Water which is driven off at high temperatures is termed water of **constitution**, and its relation to the crystalline molecule is usually considered to be entirely different from that of the water of crystallization. This difference is not only indicated by the heat of combination, but when the compound is dissolved, the water of constitution is found to occupy a much smaller volume than the water of crystallization, which is of exactly the same volume as the water of the solvent, or the water in which the salt is dissolved. Also the change of volume in case of fusion is much smaller with the water of constitution.

Water of constitution, when written in the mineral formula, to indicate this difference, is incorporated with the chemical elements, and is not written as water after the formula, as is the case with the water of crystallization. Epsomite, MgSO₄, 7 H₂O, will lose 6 H₂O at 100° C.; the seventh molecule is not separated until 210° C. is reached. The last molecule must be combined in some other or different way, and when combining with magnesium sulphate this seventh molecule will liberate twice as much heat. To indicate this difference in bond of this single molecule of water, the formula of magnesium sulphate may be written (Mg.OH)HSO₄, 6 H₂O. The water of constitution may be connected with the metal or base, forming basic water or **basic salts**, or it may be connected with the acid, forming **acid salts**.

In all acids the acid radicle is combined with hydrogen as $\begin{matrix} \text{H} - \text{O} \\ \text{H} - \text{O} \end{matrix} \rangle \text{SO}_2$, sulphuric acid. In the formation of salts this acid hydrogen is replaced with a metal. When all the hydrogen is replaced, $\begin{matrix} \text{Na} - \text{O} \\ \text{Na} - \text{O} \end{matrix} \rangle \text{SO}_2$, the salt is said to be normal, or, as rep-

resented by the formula, a normal sulphate. When only one of the hydrogen atoms is replaced, $\begin{matrix} \text{Na} - \text{O} \\ \text{H} - \text{O} \end{matrix} \rangle \text{SO}_2$, an acid salt is formed, acid sodium sulphate.

Bases form hydroxides thus, $\text{Mg} \langle \begin{matrix} \text{O} - \text{H} \\ \text{O} - \text{H} \end{matrix} \rangle$, magnesium hydroxide; when hydroxides combine with acids to form salts, all of the hydroxyl (OH) may be replaced, and the salt will be normal, in that there will be present no basic water; as $\text{Mg} \langle \begin{matrix} \text{O} \\ \text{O} \end{matrix} \rangle \text{SO}_2$, normal magnesium sulphate; or again, only a part of the hydroxyl may be replaced, $\begin{matrix} \text{MgOH} \\ \text{MgOH} \end{matrix} \rangle \text{SO}_4$, basic magnesium sulphate. Malachite is a basic copper carbonate, $\begin{matrix} \text{H} - \text{O} - \text{Cu} \\ \text{H} - \text{O} - \text{Cu} \end{matrix} \rangle \text{CO}_3$, in which one bond of the copper is taken up by hydroxyl and the other by the acid radicle. In each group of minerals, as the sulphates, there are possible normal anhydrous salts; normal salts with water of crystallization, or hydrous salts; basic salts; and acid salts; and in some of the complex mineral molecules there may be hydrated and acid and basic water present.

It is not always possible to determine the structural formula of a mineral, or to tell just what the exact relations of each atom are. The empirical or percentage formula is calculated from the results of analysis, as this is simply the reverse of the calculation of the percentage of any element from a given formula. The percentage of each oxide is divided by its molecular weight, which will give the ratios of the various oxides in the formula; thus in case of the sulphate of calcium, the mineral gypsum:

	RATIO
$\text{CaO} = 32.5 \div 56.1 = .579 = 1$	
$\text{SO}_3 = 46.6 \div 80.6 = .577 = 1$	
$\text{H}_2\text{O} = 20.9 \div 18.0 = 1.15 = 2$	

Dividing the ratios by the least of their number, as there must be whole atoms in the molecule, we obtain for CaO, one; for SO₃, also one; and for H₂O, two. The percentage formula will be CaO, SO₃2H₂O, or CaSO₄, 2 H₂O. In the mineral and crystalline molecule certain groups of elements have been found able to replace each other, and at the same time the form or angle of the crystals will be but slightly changed. Such groups of elements are very closely related to each other in several ways. Their molecular volumes are very

nearly alike. Their crystals when pure are nearly of the same angle. Compounds which replace each other are usually alike chemically in that they are salts of the same acid, as carbonates, sulphates, or phosphates; but this is not always true, since sodium nitrate, NaNO_3 , crystallizes in the same forms and nearly the same angles as calcite, CaCO_3 . Elements or compounds which replace each other in the crystalline molecule in all proportions are said to be **isomorphous**. Formerly they were thought to be of exactly the same form and angles, but at the present time it is thought that it is only necessary for the angles and molecular volume to be of nearly the same value. This is well illustrated in the isomorphous group of natural carbonates:

		Γ Α Γ	MOLECULAR VOLUME
Calcite	CaCO_3	$74^\circ 55'$	36.8
Magnesite	MgCO_3	$72^\circ 36'$	27.8
Siderite	FeCO_3	$73^\circ 00'$	30.3
Rhodochrosite	MnCO_3	$73^\circ 00'$	31.9
Smithsonite	ZnCO_3	$72^\circ 20'$	28.0

The molecular volume or volume of the unit of the space lattice is found by dividing the molecular weight by the specific gravity of the substance. If the molecular weights of crystalline substances were the same and they differed in specific gravity, then the same volume of the denser substance would contain more molecules per volume than the less dense substance, and the molecular volume or the relative size of the space-lattice units will vary inversely as the specific gravity.

Topic parameters represent the relative distances or the ratios of the distances between centers of the simple structural units of the space-point-system, measured along the three axial directions. The topic parameters are functions of the molecular volumes and the axial ratio of a compound.

The crystalline angles will vary directly with the composition; in pure calcite, with a rhombohedral angle of $74^\circ 55'$, as an end member of a series in which pure smithsonite, with a rhombohedral angle of $72^\circ 20'$, is the other end member, every molecule of zinc carbonate crystallizing with the calcium carbonate will have the effect of proportionally decreasing the angles of the calcium carbonate. The amount of decrease in the angles will be directly proportional to the percentage of zinc carbonate present. If there is no carbonate present, other than zinc carbonate and calcium carbonate, in the crystal, their percentage proportion could be calculated from

a measurement of the angles. The angles are then a function of the chemical composition.

Mesitite is a naturally occurring carbonate, forming crystals in which iron and magnesium carbonates have crystallized in proportions of two of magnesium to one of iron, and they should each have the same proportional influence on the crystalline angles:

$$\begin{aligned} \text{Mesitite, } 2 \text{ MgCO}_3, \text{ FeCO}_3 &= 145^\circ 12' \\ 2 \text{ MgCO}_3 &= \frac{145^\circ 12'}{2} = 72^\circ 36' \\ \text{FeCO}_3 &= \frac{72^\circ 36'}{3} = 24^\circ 12' \end{aligned}$$

the measured angle is $72^\circ 46'$.

The increase or decrease of the topic parameters with the addition of isomorphous substances in the molecule may not be the same in all directions. These parameters of mixed crystalline substances will increase more rapidly in one direction with the increase of the percentage of certain elements than in others. This influence will have more effect upon molecules which are comparatively simple in their structure than on those which are complex; and compounds which are isomorphous in complex mineral molecules may not be able to replace each other in such simple molecules as the chlorides. Thus potassium and sodium are isomorphous in many silicates, yet their simple chlorides crystallize in different types of symmetry.

Owing to the unequal increase in the topic parameters, complex isomorphous groups, as the pyroxenes and amphiboles, may pass through three entire crystallographical systems.

Generally the physical properties of mixed crystals, or those formed by isomorphous groups replacing each other, will stand as a mean between the properties of their constituents; and, in the strict sense of the term, compounds are isomorphous when the physical properties of their mixed crystals are continuous functions of their chemical composition.

Elements which stand in the same column in Mendeleef's table of the elements, or those of the same group, are usually isomorphous, especially in complex mineral molecules, and those which fall directly under each other in the odd and even groups are isomorphous to a great extent in simple molecules.

In group I, the alkali or univalent metals, it will be noted that lithium is written on the left, while sodium is written on the right and not directly under lithium. Two columns of elements are thus formed; any metal, as potassium, is more closely related to the

metals of the same column, as lithium and rubidium, than it is to the metals of the other column, as sodium. The elements lithium, potassium, rubidium, and caesium are isomorphous in such simple salts as the chlorides, nitrates, iodides, or sulphates; but sodium is isomorphous with these only in more complex compounds, as the feldspars, pyroxenes, or amphiboles, and complex silicates generally.

Copper, silver, and gold are isomorphous in their sulphides and as elements.

II. In the bivalent metals there are two distinct groups; the first, calcium, strontium, barium, and lead, are isomorphous in their carbonates, sulphates, silicates, and practically in all minerals.

The second bivalent group is composed of calcium, magnesium, manganese, ferrous iron, nickel, cobalt, zinc, and cadmium. Their oxides are isomorphous in the spinel group, carbonates, arsenates, tungstates, silicates. Like sodium in the univalent groups, calcium is a connecting element in the bivalent group; it is a member of both, forming a carbonate which is rhombohedral, crystallizing with the second group, and a second carbonate which is orthorhombic, aragonite, crystallizing with the first group. The two groups can replace each other to some extent in the complex silicates, as the pyroxenes and amphiboles.

III. The trivalent elements, with the exception of aluminium and ferric iron, are not common; these two replace each other in such simple molecules as the spinels; Cr_2O_3 is also included here. They are found replacing each other throughout the silicates, where Mn_2O_3 and Ti_2O_3 may be added, as in the garnets.

IV. In the fourth group, TiO_2 , SnO_2 , ZrO_2 , SiO_2 , and ThO_2 are found replacing each other in the rutile-cassiterite group of the tetragonal system. In silicates ZrO_2 , TiO_2 , and SiO_2 are found the more often replacing each other.

V. In the group of pentoxides, phosphorus, arsenic, and vanadium replace each other, as in the apatite group, and added to these are antimony and bismuth, which are all isomorphous in their sulphides and thiosulphates.

VI. In the sixth group, sulphur, selenium, and tellurium are isomorphous in the bivalent state only. In the sexvalent state the sulphates, molybdates, chromates, and tungstates are very closely related.

VII. In the fluorine group, fluorine itself stands apart from the other members of the group, the three most important of which

are chlorine, iodine, and bromine, which are completely isomorphous in such simple salts as those of silver. Fluorine enters as an isomorphous element with them only when the molecule becomes complex, as in the silicates, when hydroxyl (OH) may also replace them, as in topaz.

From a consideration of the above isomorphous groups of elements which may replace each other in the simple mineral molecule, not only will the number of elements in each isomorphous group increase with the complexity of the mineral molecules, but in the more complex silicates whole groups of elements replace each other. In the amphiboles such groups as Na_2 , H_2 , (Al_2OF_2) , (Fe_2OF_2) , $(\text{Al}_2\text{O}(\text{OH}_2)_2)$, $(\text{Fe}_2\text{O}(\text{OH}_2)_2)$ are considered to be isomorphous. It is readily appreciated that mineral species are with rare exceptions never pure chemical compounds, constant in their percentage composition, where such replacements are possible. In the attempt to deduce from the percentage analysis of any mineral its formula, and thus its relation to other mineral species, it is always necessary to group the equivalent elements, or those which belong to the same isomorphous groups, under the same head.

Thus the formula of garnet is written $\text{R}_3'' \text{R}_2''' (\text{SiO}_4)_3$, where R'' stands for all those bivalent elements or groups of elements which may replace each other in the garnet molecule; R'' usually is Ca, Mg, Fe, Mn; and R''' is usually Al, Fe, Cr, Ti, and Mn. TiO_2 may also replace SiO_2 . In the analysis of a garnet the following percentages were found; the formula would be calculated as follows:

	PER CENT.	WEIGHT	RATIOS	
SiO_2	= 41.32	÷ 60	= .689	} .691 = 3.02 = 3(\text{RO}_2)
TiO_2	= 0.16	÷ 80	= .002	
Al_2O_3	= 21.21	÷ 102	= .208	} .240 = 1.04 = R_2O_3
Cr_2O_3	= .91	÷ 152	= .006	
Fe_2O_3	= 4.21	÷ 160	= .026	} .685 = 3. = 3(\text{RO})
FeO	= 7.92	÷ 72	= .110	
MnO	= .34	÷ 71	= .004	
MgO	= 19.32	÷ 40	= .483	
CaO	= 4.94	÷ 56	= .088	

The general formula will then be:

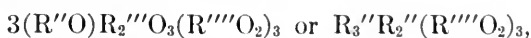

or by substituting the elements actually present for R, the formula for this garnet is $(\text{Mg. Ca. Fe. Mn})_3(\text{Al. Cr. Fe})_2((\text{Si. Ti})\text{O}_4)_3$;

placing all groups of isomorphic elements within brackets, and the most important element in each group first. It is always understood that elements thus written in a mineral formula may replace each other, and they are always written in the order of their importance in that mineral molecule. If it is wished to still further simplify the above formula, it is at once seen that both titanium and manganese are present in only very small amounts and may be neglected in the formula.

Classification of minerals. — Any natural classification of minerals must consider both the chemical and physical properties of the mineral, but as the physical properties depend to a large extent upon the elements present, the chemical relations of the elements in the mineral molecule are given more weight in the scheme of classification than the presence of any one element. Minerals are therefore classified as chemical compounds, following the order of the natural classification of the elements, but the acid radicle will determine the group; for example all sulphates are placed in the same large group. The subheads are determined by the character of the salt; whether it is anhydrous, basic, acid, or hydrated, as well as by a consideration of its crystalline type. By this method of classification those minerals which form natural isomorphous groups are kept together; for example, barium, strontium, calcium, and lead sulphates are placed in the same group of anhydrous sulphates, as they should be, since they crystallize in the same type and are isomorphous. If they were classified from their basic or metallic elements, they would be widely separated in four different groups, even though they are all found in nature under the same conditions and often several are mixed in the same crystals.

The system of classification here adopted is that of Dana, which may not be in all respects the most desirable, yet most of the mineral collections in the American museums follow this system in their arrangement. Not taking into account the hydrocarbons, there are eight large groups in this scheme, as follows:

I. Native elements. Includes the elements which occur in nature in an uncombined state, as gold, copper, silver, sulphur, diamond, etc.

II. Sulphides, including the arsenides, antimonides, and other similar compounds. Mostly salts of hydrogen sulphide, H_2S , as galena, PbS ; also including the corresponding compounds of tellurium and selenium.

III. Sulpho-compounds, as the sulpharsenites, sulphanti-

monites, etc. Derived from such acids as $\text{As} \begin{cases} \text{S-H} \\ \text{S-H} \\ \text{S-H} \end{cases} = \text{H}_3\text{AsS}_3$,

as proustite, Ag_3AsS_3 . The group also includes basic, acid, normal, and meta groups.

IV. Haloids, or salts derived from the haloid acids, as HCl , HBr , HI , and HF ; halite, NaCl ; iodyrite, AgI ; bromyrite, AgBr ; fluorite, CaF_2 .

V. Oxides, or the combinations of the elements with oxygen.

a. The oxides of the univalent metals, as cuprite, Cu_2O .

b. Oxides of the bivalent metals, as zincite, ZnO .

c. Oxides of the trivalent elements, as corundum, Al_2O_3 .

d. Oxides of the quadrivalent elements, as quartz, SiO_2 .

Also included in this group are the hydroxides, in which the base is combined with hydroxyl, as brucite, $\text{Mg}(\text{OH})_2$.

The aluminites, ferrites, and chromites, salts of such acids as HALO_2 , as spinel, $\text{Mg}(\text{AlO}_2)_2$, or of $\text{H}(\text{FeO}_2)$, as magnetite, $\text{Fe}(\text{FeO}_2)_2$, and chromite, $\text{Fe}(\text{CrO}_2)_2$, are included in this group, though they must be considered as salts and not oxides.

VI. Salts of the oxygen acids.

a. Carbonates, H_2CO_3 , as CaCO_3 , calcite; basic carbonates, as malachite, $(\text{CuOH})_2\text{CO}_3$, and hydrous carbonates, as trona, $\text{Na}_2\text{CO}_3 \cdot 10\text{H}_2\text{O}$.

b. Silicates, titanates, etc.

Orthosilicates are the normal salts of the tetrabasic acid, H_4SiO_4 , as fayalite, Fe_2SiO_4 .

Metasilicates. Orthosilicic acid by a loss of some of its water forms the dibasic acid, metasilicic acid.

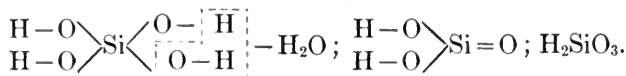

There are many minerals which are salts of this acid, as enstatite, MgSiO_3 , or leucite, $\text{KA1}(\text{SiO}_3)_2$.

Diorthosilicic acid is derived from two molecules of orthosilicic acid by the loss of one molecule of water.

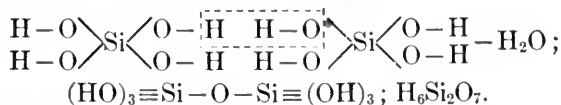

It is an hexabasic acid, an example of which is barysilite, $\text{Pb}_3\text{Si}_2\text{O}_7$.

Dimetasilicic acid is derived from two molecules of an orthosilicic acid by the elimination of three molecules of water, or from two molecules of a metasilicic acid by the elimination of one molecule of water.

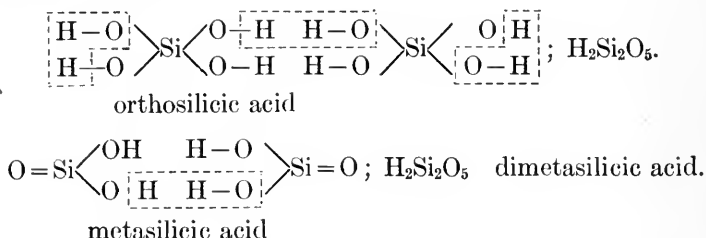

Example, Petalite, $\text{LiAl}(\text{Si}_2\text{O}_5)_2$.

Trisilicic acid is an acid obtained from three molecules of the orthoacid by the elimination of four molecules of water.

Orthosilicic acid

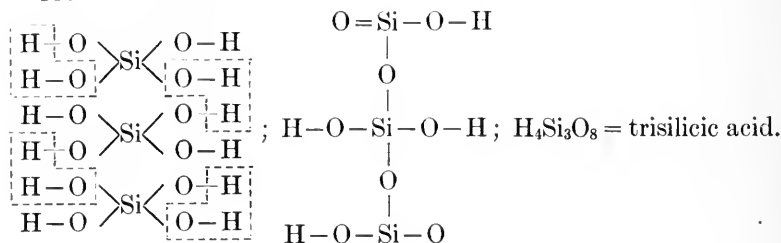

Example, Orthoclase, KAlSi_3O_8 .

In some minerals several silicic acids may be present in the molecule, and a mineral may be a mixture of two or more of these acids and yet on analysis yield the same percentage results of oxygen and silicon. From inspection alone it is impossible to determine whether the analysis represents a metasilicate or a trisilicate and orthosilicate mixed; to this difficulty must also be added the chances of basic, acid, and hydrated salts being present. For the same analysis several structural formulæ of the mineral may be written, all of which will represent the results equally well; thus, andalusite, Al_2SiO_5 , may be written as an orthosilicate, $\text{O} = \text{Al} - \text{SiO}_4 \equiv \text{Al}$, or as a metasilicate $(\text{AlO})_2\text{SiO}_3$, both of which will yield the same percentage composition on analysis.

The probable structural formula is derived from a study of the decomposition products of any mineral, as well as by a thorough study of its synthesis where that is possible. In the case of anda-

lusite, it decomposes, forming muscovite. The formula of muscovite is that of an orthosilicate, and when written in the form of a substitution product in the normal aluminium orthosilicate is as follows:

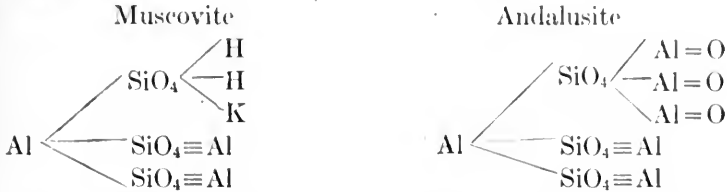

In the formation of muscovite from andalusite, hydration attacks the Al = O group, forming gibbsite, Al(OH)₃, which at the same time may be carried off in solution. The necessary potassium for substitution in the formula of andalusite to form muscovite is furnished by the potassium carbonate dissolved in the ground water.

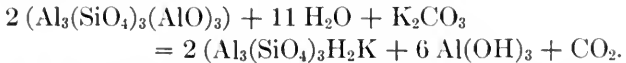

If the formula as written for muscovite is true, it would follow that the formula as written for andalusite would be most probable and it would be an orthosilicate.

In the case of pyroxene and amphibole, from their analysis alone both could be expressed by the formula, R''SiO₃, as metasilicates, in which R'' represents practically the same group of isomorphous elements. Their crystallographical constants and physical properties are, however, quite different, indicating entirely different molecular structures. Pyroxene is more dense than amphibole, which taken with the evidence of uralitization, a process in which amphibole is formed from pyroxene, with but little chemical change, would indicate that the molecule of pyroxene is more compact than that of amphibole and uralitization is the breaking down of a complex but compact molecule into less dense and simple molecules. Pyroxene is therefore usually considered as a metasilicate, while amphibole may be written as a mixed silicate composed of the orthosilicic acid and the trisilicic acid, preserving the ratio of silicon to oxygen as found in analyses.

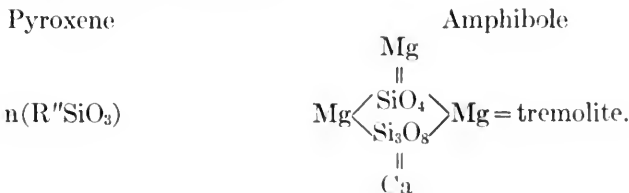

The alteration and relation of many orthosilicates is easily explained, and their formulæ may be written as substitutions in the general formula of an aluminium orthosilicate, in which the aluminium is replaced by other bases.

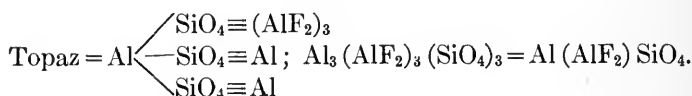
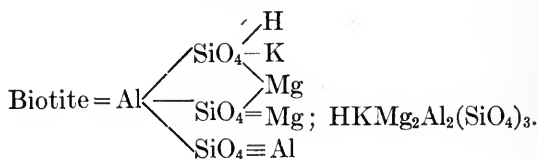
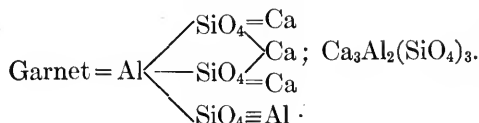
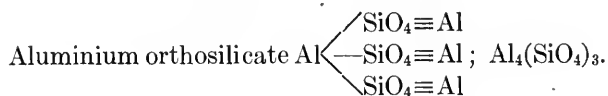

c. Columbates and tantalates.

Salts of columbic acid, HCbO_3 , as columbite, $(\text{Fe.Mn})(\text{CbO}_3)_2$, an orthocolumbate of iron and manganese.

Tantalates, salts of tantalic acid, HTaO_3 , as tantalite, $\text{Fe}(\text{TaO}_3)_2$.

d. Phosphates, arsenates, and vanadates, etc.

Salts of the acids, H_3PO_4 , H_3AsO_4 , H_3VO_4 ; as xenotime, YPO_3 ; berzelite, $(\text{Ca.Mg.Mn})_3(\text{AsO}_4)_3$; and pucherite, BiVO_3 .

e. Borates and uranates.

Salts of boric acid, as sassolite, H_3BO_3 ; also bborates, as borax, $\text{Na}_2\text{B}_4\text{O}_7$.

f. Sulphates, chromates, and tellurates.

Salts of sulphuric acid, as barite, BaSO_4 . Salts of chromic acid, as crocoite, PbCrO_4 .

g. Tungstates and molybdates.

Salts of tungstic acid, H_2WO_4 , as wolframite, $(\text{Fe.Mn})\text{WO}_4$.

Salts of molybdic acid, as wulfenite, PbMoO_4 .

In most cases the above acid groups include, in addition to the normal salts, hydrated, acid, and basic salts, as well as complex molecules, the exact structure of which has not in all cases been determined.

CHAPTER II

THE ORIGIN OF MINERALS

THE origin of all minerals must have been from solutions and gases, or the result of the interaction of these on minerals previously separated from solution. It is of very little difference whether the solution is one of water or of fused silicates, homogenous and fluid only at high temperatures. In either case the same laws will apply, and the same physical and chemical laws will hold true whether that solution is but a thimbleful of silicate fused in the electric furnace of the laboratory or contained in the enormous crucibles of nature. Practically the same conditions can be duplicated in the laboratory with the exception of time and pressure. Time is the factor so essential for the formation of large and perfect crystals.

Most minerals, at least the common species, have been synthesized or artificially produced in the laboratory. The exception is a class of minerals which it is believed have been formed under pressure and in the presence of water, or they belong to that class which are produced by contact metamorphic conditions, in most cases, as the micas, epidote, topaz, vesuvianite, and amphibole. The artificial products lack water in their constitution, and therefore the conditions under which they were formed in nature have not been reproduced or duplicated in case of the artificial product.

Indeed the conditions surrounding the crystallization of any mineral in nature must be excessively complex. The conditions under which individual minerals may form as conditioned by temperature, pressure, and other components in the system have been studied in but few cases, and in these the result has been the discovery of unknown, unsuspected phases, which have been of great assistance in the explanation of the various isomorphous series, containing the same elements but of different symmetry.

In order to arrive at some small conception of the importance and influence of one compound or component in solution on the separation or crystallization of another component of the same system, it is probably best to illustrate by a system in which the relations are

as simple as possible and with one which is familiar to all, as the solution of salt in water — a two-component system easily tried and from the consideration of which the application of the terms and diagrams may be appreciated.

If any crystalline substance is heated and the application of heat is constant and continuous, the temperature of the crystalline solid increases constantly; in time a temperature will be reached at which the solid passes to the liquid state or the solid is said to fuse or melt. The molecular network or point-system of the crystalline state is broken down. If the temperature of the system when the two phases, solid and liquid, are in contact is measured, it will be found that this temperature is a constant one, providing that the compound is chemically pure and the pressure is the same. Thus ice when heated to 0° C. melts and forms water; this temperature of fusion is the **melting point**. Water is an exception to the general rule, and the melting point of water is lowered with an increase of pressure, the reverse of the conditions in most other substances. The transition of a solid crystalline substance to a liquid is an abrupt one, and there is no constant decrease of viscosity, with the rise of temperature, to be noted in case of the crystalline substance as is the case with the amorphous solid. In the amorphous solid there is no constant sharply defined temperature of fusion, no abrupt change from solid to liquid. The viscosity simply decreases with the rise of temperature. The line of separation between liquids and solids, when considered from this standpoint, should be drawn between the crystalline substances and amorphous substances rather than between solid amorphous substances and the ordinary liquids.

The difference between amorphous solids, which are excessively viscous liquids, and the ordinary liquid is very little; and the amorphous solid is more closely related to liquids than to crystalline solids.

Water and ice are two modifications of the same chemical substance, between which there is an abrupt change or transition from one to the other. Each of these modifications is known as a **phase**. Water can exist in three phases: solid, ice; liquid, water; and vapor or gas, steam, depending upon the temperature and pressure. Sulphur may exist in two solid crystalline phases, monoclinic and orthorhombic sulphur; the transition temperature between these two phases at ordinary pressure is 95.6° . Many solid compounds as minerals have different solid phases. Leucite

is orthorhombic at ordinary temperatures, but at 500° C. it passes over to an isometric phase. In like manner quartz, when heated to a temperature of 575° , β -quartz is formed, and crystals in passing this inversion temperature are shattered; if the temperature is still raised, at 800° C. another inversion point or temperature is reached, when a third phase, or tridymite, is the stable form.

Different phases of the same substance can exist in equilibrium with each other only when the temperature and pressure are fixed.

Ice and water are in equilibrium and can exist in contact with each other at 0° C. and under one atmosphere of pressure. When two phases of the same substance are in contact, for each pressure there is a fixed definite temperature of equilibrium, and for every fixed temperature there is also a fixed pressure of equilibrium.

If ice is heated and the heat is applied at a constant rate, the temperature of the ice will rise regularly; as for every gram of ice a constant amount of heat is required to raise the temperature one degree, this quantity of heat is designated the **specific heat** of the substance. If the temperature is taken every ten seconds and the curve is plotted with temperature and time as ordinates and abscissa, the curve will be found to be continuous and regular until 0° C. is reached, when there is an abrupt change in the behavior of the system, as water, or the liquid phase, begins to form. The rise of temperature is stopped and remains the same, just as long as there is any ice or solid phase present. At this point, Fig. 368, the heating curve runs along horizontally and there is no rise in temperature, since the melting ice absorbs heat in passing in to the liquid phase. This absorbed heat is the **heat of fusion**; and when water is transformed to the solid phase, ice, the same amount of heat is liberated, and the cooling curve will show the same horizontal portion at 0° C.; such an interruption in the regular trend of the cooling or heating curve is a **halting point**. Such halting points mark the transition temperatures between two phases of a substance and are caused by the absorption or liberation of heat. The heat liberated by a solid crystallizing is often termed the **heat of crystallization**; this is a constant source of heat, available, in magmas that are crystallizing, to counteract radiation and serves to prolong the liquid state and to modify the rate of cooling. In such fluid and crystallizing magmas each substance which crystallizes and separates from the solution will have a direct influence upon the temperature at which other substances in turn crystallize; and each compound dissolved in the magma will also influence

the temperature at which crystals of every other compound contained in the solution will begin to form.

If two substances as salt, NaCl , and water are taken, and the salt is dissolved in the water, a two-component system will result. From a saturated solution of salt in water, salt crystals separate without water, and water will separate as ice without salt; these conditions are the simplest possible. Salt crystals and ice are the two solid phases and dissolve in each other to the liquid phases. If one substance is dissolved in another, as salt in water, the temperature of fusion is always lowered or the temperature of solidification of both components is lowered. The change in temperature at which each will solidify caused by the addition of the other is known as the **lowering of the freezing point**. If water at 60°C . is surrounded by a temperature of -30° and its cooling curve is plotted, Fig. 368, the curve will be regular until 0°C . is reached, when ice crystals will form and the temperature will halt at this point as long as there is any water to be transformed to ice and absorb heat, when the lowering of the temperature will proceed in a regular manner, as before. If to the water, or liquid phase, salt be added to, say, an amount of 15 per cent., then if the system be cooled as before, when 0°C . is reached, the curve will show no indication of a halting point and no ice crystals will form until the temperature has fallen far below the freezing point of water, as the freezing point of water has been depressed by the addition of salt, and ice will not form until a temperature is reached corresponding to the amount of salt added. In the case of a 15 per cent. solution this temperature is -12.2° . As ice crystals separate, the composition of the remaining solution is constantly enriched in salt and impoverished in water by the ice formed, which is unmixed with salt. As the percentage of salt increases, this lowers still further the freezing point of the remaining solution, (indicated by the curve **AB**), until the temperature is lowered to or reaches -22.4° , where there is a halting point, until the liquid phase disappears. At this point both salt and ice are formed and solidify as a whole; the temperature, owing to the heat of crystallization, remains constant until the liquid phases have entirely disappeared, after which the cooling will proceed in a regular manner. If the mixture of salt and water which solidifies as a whole when the temperature of -22.4° is reached be analyzed, its composition will always be found constant, and it is composed of 77 per cent. of water and 23 per cent. of salt, and no matter what

the percentage of the original solution might be, upon cooling either salt or water will separate from the solution as the case may be and continue to do so, as the temperature is lowered, until the constant percentage mixture of 77 parts water and 23 parts salt is reached at -22.4° , when the solution will solidify

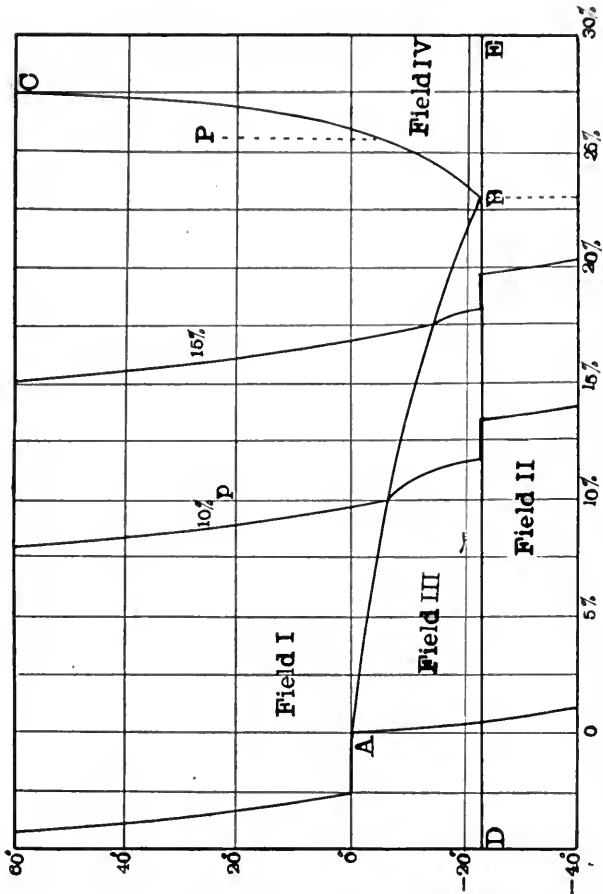

Fig. 368. — Fusion Diagram of the Two-component System, Salt and Water.

as a whole. Such mixtures, which have a constant composition and solidify as a whole at definite temperatures under like conditions, are termed **eutectic mixtures**. Fig. 368 is a so-called fusion diagram of a two-component system, water and salt. The plan, one in which temperatures are measured vertically and percentages horizontally, is divided into four fields of conditions by the two curves **AB** and **BC** and the straight line **DE**. In field I,

above both curves, is the liquid field, in which all possible mixtures of water and salt may exist as homogeneous solutions and be in equilibrium at the corresponding temperatures. This field is bounded by the two curves **AB** and **BC**. The curve **BC** is the boundary between homogeneous solution and field **III**, in which ice crystals and salt solution are in equilibrium. If any point in field **I** is selected, as **p** corresponding to a temperature of 20° and 10 per cent. NaCl, at 20° this solution is homogeneous, but if cooled, the 10 per cent. solution will meet the curve **AB** at a point corresponding to -6.7° , and at that temperature ice crystals will begin to separate and the conditions of field **III** will be reached, in which ice crystals are in equilibrium with salt solution. If a point on the opposite side of the diagram, as **P**, be taken, on cooling, the perpendicular from **P** cuts the curve **CB** at -5° , at which temperature the solution will be saturated in regard to the salt, and salt crystals will form, when the solution or conditions will be those of field **IV**, in which salt crystals and salt solution are in equilibrium. As the temperature falls, the solution becomes more concentrated in respect to the water content and the temperature of separation follows the curve **BC** until **B** is reached, when both salt and ice separate in **eutectic proportions** of 77 parts water and 23 parts salt, at a temperature of -22.4° . Below the line **DE** or below the point **B** or a temperature of -22.4° , liquid solution cannot exist, and field **II** is the crystalline or eutectic field, separated from the other three fields in which liquid solutions are possible by the straight line **DE**, known as the **eutectic horizontal**. It often happens, and it is indeed the rule, that the temperature will fall below that indicated by the curve of separation without crystals being formed, unless care is taken to prevent it; such a solution is said to be supercooled. If the 10 per cent. salt solution should fall below -6.4 without the separation of ice, it would be supercooled and in a metastable condition, the solution being supersaturated as regards water; such a condition could not exist if the least particle of ice were present. On dropping a particle of ice in the supercooled solution there is an immediate separation of ice, a rise of temperature from the heat of crystallization, as well as an increase of the concentration of salt in solution, and the whole system comes to a state of equilibrium on the curve of separation. A good example to illustrate supersaturation is a solution of sodium sulphate, Na_2SO_4 , $10 \text{ H}_2\text{O}$, dissolved in water and heated in contact with the salt, or saturated at a temperature a little below 32° C. ; if it is

heated to a temperature above 32° the anhydrous salt Na_2SO_4 will separate at 33° . The solution is carefully poured off the crystals in a flask and the mouth of the flask stoppered with cotton to prevent the access of dust or fine particles of sodium sulphate from the air, which would start crystallization and prevent supercooling or supersaturation. Such a solution may be cooled to room temperature and kept for a long time without the formation of crystals. This solution is supersaturated in regard to the salt $\text{Na}_2\text{SO}_4, 10 \text{H}_2\text{O}$; if the smallest particle of this salt is dropped into it, the solution solidifies almost at once, with a rise in temperature, and the system soon reaches a state of equilibrium, as between the solid $\text{Na}_2\text{SO}_4, 10 \text{H}_2\text{O}$ and solution.

The supercooled solution is in the **metastable** state, and the tendency to form crystals spontaneously is very small; if cooling is continued, however, a temperature will be reached at which a cloud of small crystals will form spontaneously, or a number of crystalline nuclei will form without inoculation with a solid particle, and thereafter the system quickly reaches equilibrium.

In the case of igneous rocks, before consolidation they may be said to represent solutions of various components, each of which will have an individual and separate influence on the temperature of separation of every other dissolved component in the magma, and the freezing curve, or the curve of separation of any crystalline form or phase separating, will be the resultant of all these depressions. Where the number of components is quite large, six or eight, as it is in most magmas, the system becomes excessively complicated. Upon the whole, when cooled to the metastable stage of one or more of the components, a temperature will be reached at which crystalline nuclei will form spontaneously, and the minerals will separate from the magma in the order of their freezing points or saturation for that particular system, and each individual crystal will continue to grow as cooling of the magma continues. In the fusion diagram, fields III and IV, other things being equal, would represent a porphyritic development of one or two species; the individual crystals of each would be contained in a ground mass of fine crystals, representing the final disappearance of solution, or the eutectic mixture composed of the last to crystallize, Fig. 369. The eutectic mixture in its crystallization always presents a peculiar, intimate intergrowth of the components. This is seen in the micropegmatitic intergrowths of quartz and orthoclase, Fig. 370. Eutectics are often formed between garnet and quartz; magnetite and horn-

blende; quartz and tourmaline. Ternary and quaternary, eutectics are also possible. Eutectic consolidation will at times represent a second generation



FIG. 369.—Porphyritic Feldspar Crystals in a Fine Grained Crystalline Ground Mass.

of small crystals, surrounding the porphyritically developed crystals of the first generation.

Minerals which are crystallized from molten magmas are usually anhydrous or contain small amounts of water, as the micas, and are termed primary minerals, to distinguish them from secondary minerals, which have resulted from water solutions, the components of which have resulted from the breaking down of other minerals.

The order of crystallization of the primary minerals from magmas is not rigidly fixed, but may vary according to the composition of the magma, as the curve of separation of any individual species is the result of the lowering of the freezing point of that individual by all the other components of the system, and these may have a greater effect on one than on another. The order of crystallization and the relation of the crystals of one species to those of another species will depend upon and reflect magmatic peculiarities. There are, however,

The order of crystallization of the primary minerals from magmas is not rigidly fixed, but may vary according to the composition of the magma, as the curve of separation of any individual species is the result of the lowering of the freezing point of that individual by all the other components of the system, and these may have a greater effect on one than on another. The order of crystallization and the relation of the crystals of one species to those of another species will depend upon and reflect magmatic peculiarities. There are, however,

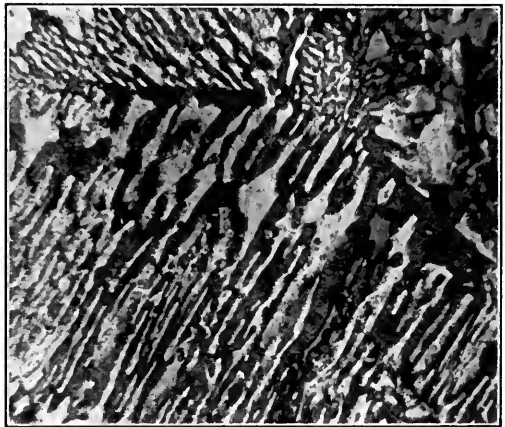

FIG. 370.—Section of a Micropegmatite enlarged, showing Eutectic Structure.

There are, however,

certain minerals which ordinarily separate during the early stages of crystallization, or the solution becomes saturated in respect to them long before it is saturated in respect to others. Minerals which are early to crystallize are well formed and exhibit crystalline outlines in the rock section. They may be contained as inclusions in the crystals of those minerals which form later, as the crystals of apatite in magnetite, or magnetite in feldspar. The crystals of minerals among the last to separate are usually irregular and act as a ground mass, filling the spaces between crystals which have separated at an earlier stage. In the common magmas it may be stated that separation takes place with a progressive increase of silica. Those minerals high in silica, as quartz, are near the end products of crystallization.

Among the first to separate are metals, sulphides, oxides, and included here are apatite and zircon; second, the ferromagnesian silicates, as pyroxene, amphibole, and olivine; third, feldspars, beginning with the basic plagioclases and ending with orthoclase; and lastly quartz. This order of crystallization must be considered only in a general way, as several may overlap in their periods of separation, and this overlapping may be continued to such an extent that the order of adjacent minerals in the list or order of crystallization is reversed. Magmas homogeneous at high temperatures may upon cooling separate into several portions which are immiscible at lower temperatures, each of which will have an individual character and composition, even before crystallization has begun.

In the crystallization of magmas, the viscosity has a great influence upon the crystals formed and upon crystal growth. With the decreasing temperature there is usually an increase of viscosity, which tends to prevent the formation of centers of crystallization, and is therefore a check generally to crystallization; and the very viscous magma has a predisposition to solidify as a glass. The fluidity of minerals at their fusing point varies greatly, even within isomorphous groups; as the potash feldspar, orthoclase, is exceedingly viscous at its point of fusion, — crystals form in a fusion of its components with great difficulty or not at all; while the calcium feldspar, anorthite, crystallizes with the greatest ease from the simple fusion. Viscosity decreases with the increase of basicity, as iron, calcium, magnesium, and sodium promote fluidity, potassium and silica promote viscosity, and aluminium has but little influence either way. Those rocks containing pyroxene, hypersthene, enstatite, or olivine are more apt to contain well-formed crystals than

those containing feldspathoids, silica or alkali feldspars, when under the same conditions.

In the synthesis of minerals it has been proven without doubt that certain minerals are easily formed from a simple fusion, composed of their chemical constituents in correct proportions; in all cases these fusions are not highly viscous in nature. The plagioclases, magnetite, hematite, rutile, spinels, corundum, some garnets, leucite, olivine, and enstatite have all been formed from simple fusions in an open crucible. They are all rock-forming minerals, and in nature they have in many occurrences been crystallized directly from a fused magma.

Mineralizers. — On the other hand there is a group of minerals which it has been impossible to synthesize by the open fusion method, as there is contained in their molecule small amounts of volatile compounds as fluorine, water as hydroxyl, or chlorine; or again the fusion at the point or temperature of crystallization is so viscous as to prevent the formation of crystals, when the fusion cools as a glass. Many granites, syenites, and gabbros are exceptionally well crystallized and contain orthoclase, albite, quartz, amphibole, and micas, minerals which from the experience with open crucible fusions of their chemical components cannot be crystallized, and the formation of crystals requires other substances to be present in the fusion, as water, fluorine, boron, chlorine, tungsten, etc., even though these elements are not a part of the mineral molecule formed. Such elements are termed **mineralizers** from the rôle they play in the formation of certain minerals. They do, however, enter the molecule of some of these rock-forming minerals in very small quantities, as the micas always contain small amounts of hydroxyl and fluorine, apatite contains fluorine and chlorine, and tourmaline contains boron as a molecular essential.

Mineralizers are fluxes in that they decrease the viscosity of magmas in the same sense that fluorite is used in many smelting operations to attain the same end, that of forming a liquid slag. They are solvents in the same sense that water is a solvent for salt in the two-component system illustrated, and in each case they lower the fusing point or the temperature of separation to such an extent that it is possible for molecules to form at a much lower temperature and at temperatures far below their actual melting points, as many minerals are unstable at their temperature of fusion and break down into components formed of molecules of a less com-

plex nature, and it is not possible for them to form at the temperature of their freezing point. Such minerals are termed the low temperature minerals. Their molecules are considered to be more complex than those which form from direct fusion and without the aid of mineralizers, or the **high temperature minerals**. In the low temperature minerals are included the amphiboles, micas, sodalites, nepheline, tourmaline, topaz, beryl, titanite, quartz, albite, and orthoclase, and also many rare minerals of the pegmatites. In the synthesis of this class a mineralizer must usually be present, either to lower the fusing point or to reduce the viscosity of the melt, while some, as topaz, tourmaline, and muscovite, have never been produced artificially.

That mineralizers have been present during the stage of crystallization of such rocks as granite, syenite, and pegmatites is shown by the simple fact that the quartz of such rocks always contains numerous cavities holding liquid inclusions, and that the micas contain hydroxyl and fluorine. The mineralizer is usually a volatile substance or forms volatile compounds with the bases as the fluorides, and therefore when the magma is extruded they escape, and with their escape the tendency to quickly solidify and the formation of glass is increased. Basalts are more often crystallized than are the rhyolites and andesites, as in the latter the mineralizers have escaped, leaving the magma by nature too viscous to crystallize. The coarse crystalline forms, granite and syenite, are plutonic rocks and have crystallized under conditions which preclude any escape of the volatile mineralizers, or they have escaped very slowly.

In the process of cooling, those compounds which are the more insoluble have separated first, with the result that the remaining liquid portion is a concentrated solution of the more soluble, and the dykes, veins, and marginal masses connected with some granites and known as pegmatites are the result of and represent the ultimate concentration of some of the constituents of the original fused magma. Crystals of pegmatites are large and well formed, and such dykes contain minerals in quantity which are rare accessories in the rock mass as a whole. There seems to be no good reason why the condition should not change during crystallization from that at the beginning, a fused magma, at a high temperature, far above the critical temperature of water, 365° C., to that at the end, when the final product of crystallization may be separated from a solution in water, though hot and under pressure.

Pneumatolysis. — Most mineralizers form gases and volatile compounds which penetrate the cracks, cavities, and pores of adjacent rock formations, where they may be condensed, or by decomposition deposit compounds; or by the reduction of temperature and pressure deposit compounds carried in solution; or by the direct interaction with the rock mass form minerals, all of which are concentrated near the margin of large intruded igneous masses and extending out as impregnations in the sedimentary formations of the immediate vicinity. Numerous ore deposits are of this nature, especially those of tin or cassiterite, where the tin has been concentrated by a squeezing out of the volatile tin fluoride to be decomposed by contact with steam; it deposits SnO_2 in the open veins and cracks of the formation; this decomposition produces hydrofluoric acid to further react with the walls of the formation to produce such minerals as fluorite and topaz. Minerals formed by the action of gases or volatile compounds are said to be **pneumatolytic** or formed by **pneumatolysis**. The gases most active in pneumatolysis are fluorine, water or steam, hydrogen sulphide, boron, chlorine, and their volatile compounds.

Typical minerals formed by this process are tourmaline, topaz, cassiterite, rutile, oxides of iron, micas, fluorite, quartz, sulphides of copper, lead, arsenic, also titanite and axinite, and numerous rare minerals as wolframite, scheelite, uraninite, and allanite.

Intimately connected, possibly with the last stages of cooling of large intruded igneous rock masses, is the formation of the so-called contact minerals; produced by the interaction of and the impregnation of the formation by steam and associated with the heat of contact and pressure. This stage directly follows that of the pneumatolytic action of gases and is usually termed **thermal metamorphism**, though heat is connected with all metamorphic changes; in this case the temperature is comparatively high, especially near the contact of the igneous rock intruded. The minerals formed under such conditions, when the volatile gases are prevented from escape and are held under pressure, are of a complex nature when contrasted with those formed where there is a ready escape of gases.

The materials at hand for the formation of new minerals are not only those contained in the sedimentary formation under the process of alteration, but also those elements carried in solution, by the interaction of which at high temperatures and pressure and continued through long periods of time large and most beautifully de-

veloped crystalline specimens are formed. In such regions hydrated minerals as the zeolites, kaolinite, etc., are dehydrated, forming feldspars; silicic acid will replace carbonic acid in limestones; and large areas of limestone have been almost entirely replaced by such silicates as scapolite, pyroxenes, micas, tourmaline, and feldspars. Other characteristic minerals of contact metamorphism are epidote, garnets, vesuvianite, spinels, wernerite, andalusite, corundum, apatite, biotite, phlogopite, and all those minerals so common in the granular limestones. Practically there is no sharp line to be drawn separating the two processes of thermal or contact metamorphism and pneumatolysis; one begins where the other leaves off, and the two are so intimately related in the formation of some contact minerals as to be quite impossible of separation.

The volatile matter given off by hot intruded magmas may possibly be exemplified by a study of the gases escaping from active volcanoes, though the difference here would be that of a great decrease of pressure. With the relief of all pressure, only those compounds would exist which are stable at atmospheric pressures, compounds possibly quite different from those which are in solution and which are stable under high pressures and where the volatile gases do not escape freely. The common gases emitted from volcanoes, solfataras, and fumaroles are hydrogen sulphide, sulphur dioxide, carbon dioxide, hydrochloric acid and volatile chlorides and fluorides, steam, nitrogen, and other gases in much smaller quantities. Many minerals are formed as sublimates by the direct condensation and interaction of these gases. They are usually simple in their molecular structure, in contrast to those formed at depths and under pressure. Sulphur is usually present, a product formed by the interaction of SO_2 and H_2S , also sulphates and chlorides, as NaCl , PbCl_2 , and where the temperature is high, the chlorides are decomposed, forming oxides as melaconite (CuO), cuprite, magnetite, and hematite; all these minerals are known in the lavas around Vesuvius.

Hot Solutions. — After the cooling of an injected magma has progressed to such a degree that it is possible for the water to exist as such or the temperature has fallen below 365° , the critical temperature of water, then many minerals are formed or deposited from the water solutions. Water under pressure dissolves many compounds with ease which at the surface or under normal temperature and pressure are but slightly soluble or are considered to be insoluble. The solubility of many substances is greatly

increased by other components in the solution, especially CO_2 , H_2S , HCl , HF , or alkalies.

All substances, even the most insoluble, are dissolved in slight amounts; insolubility is only a relative term. Gold itself is soluble in water and especially so in the presence of ferric chloride, and solutions of colloidal gold will retain the metal without separation for a long time. Solubility is also increased with an increase of pressure, provided that the total volume of solute and solvent is decreased by solution. Hot flowing waters under pressure are therefore very complex solutions, and are usually nearly saturated with compounds which at the surface would be considered insoluble. When such solutions, flowing through the veins and fissures of the adjacent formation, gain access to regions of lower temperatures and pressures, they are in a state of unstable equilibrium, and some of their components are deposited. As the directional flow is constant for long times, these streams of solutions serve to concentrate the soluble components in the fissures and veins, where they are deposited, often in definite order and at times filling completely the original veins and fissures along which the solutions flowed. Many ore deposits filling veins, fissures, and pipes have been concentrated by this method; and often where such heated solutions reach the surface, as at the Steamboat Springs of Nevada, the deposition of sulphides has been noted. Pyrite, chalcopyrite, galena, arsenides, antimonides, and many minerals of like character have been deposited on the walls of channels by the hot solutions flowing through them.

When minerals are crystallized under high pressures, the molecules are compact, and the minerals formed are of a phase in which the specific gravity is high; as quartz, with a specific gravity of 2.65, will form rather than tridymite, with a specific gravity of 2.3. Tridymite occurs in surface lavas where it has crystallized at reduced or atmospheric pressures. High pressures, other things being equal, will induce the formation of pyrite, with a specific gravity of 5 rather than marcasite with a specific gravity of 4.9. As solids in the crystalline phase occupy less space or have a higher specific gravity than the amorphous phase, high pressures will tend to dissolve the amorphous phase and to redeposit the chemical compound as crystalline. Large areas of amorphous limestones have been thus crystallized under pressure. Ordinary obsidian when crystallized will occupy less space and during crystallization will shrink from 3 to 11 per cent. of its original volume. Garnets, feld-

spars, micas, pyroxene, amphibole, epidote, spinels, and andalusite are minerals which form under high pressures; the latter are dense minerals and differ entirely from minerals formed at or near the surface, where hydrated minerals are the rule, a class quite unstable under high pressures and heat. Under such conditions the latter are quickly transformed to the more stable compact molecule. If the minerals which have been formed at depths are brought to the surface, they become the less stable phase, when they are subject to change and decomposition, either through the solution of some of their constituents, or oxidation, or by replacement of some elements by others.

The action of ground waters.—Water falling as rain passes through and over the soil, following the course of least resistance, constantly taking up and carrying along soluble compounds. As CO_2 is absorbed from the soil and the air, its solvent power on other carbonates, as calcium carbonate, is thereby increased; such carbonates in solution are considered as the bicarbonates and are more soluble than the normal salts.

There is an area near the surface, usually termed the area of oxidation or weathering, in which the pores and cavities of the soil and rocks are not completely filled by the percolating waters. In this area oxygen is an active agent, and many minerals are oxidized as they are carried in solution, or oxidation is the cause of precipitation. In this area sulphides, as pyrite, are oxidized to sulphates, forming ferric and ferrous sulphates, both of which are soluble and carried in solution by the descending ground waters, to act as powerful reagents in the transformation and solution of other minerals. In the area of oxidation, such processes as carbonation and hydration, in addition to oxidation and solution, are active, resulting in the formation of carbonates and many hydrated minerals and hydroxides, as limonite and the oxides of manganese, and aluminium, as well as sulphates, arsenates, and phosphates. In this region carbon dioxide can replace silica, the silica being carried in solution to be again deposited either as the amorphous form, opal, or as quartz, according to conditions. This reaction is the reverse of that which takes place at greater depths and under the influence of heat and pressure, where silica replaces CO_2 . Upon the whole minerals in the zone of oxidation or weathering are decomposed and disintegrated, forming products which with the addition of water and oxygen have increased in volume, and in the production of which hydration and oxidation are most important processes.

In the percolating ground waters many sulphides are soluble, and especially so as these waters are acid in some cases and alkaline in others. These solutions finally, in their descent, reach the area where the pores, fissures and cavities of the rocks are completely filled; and the solution joins that reservoir of ever flowing water termed the **ground water**; where through the action of diffusion and flowage, solutions of various substances are mixed as reagents in a beaker, with the resulting precipitations. Here, however, the walls of the containing cavities are active agents and by the interchange of their elements enter the reactions as important factors in the process of chemical replacement, or metasomasis.

The products of the oxidation of pyrite are varied, according to the conditions and the amount of oxygen available.

$\text{FeS}_2 + 6\text{O} = \text{FeSO}_4 + \text{SO}_2$, which yields a solution of ferrous sulphate and an acid solution. $2\text{FeS}_2 + 14\text{O} = \text{Fe}_2(\text{SO}_4)_3 + \text{SO}_2$, yielding a solution of ferric sulphate and an acid solution. This solution may interact with more pyrite, $\text{FeS}_2 + \text{Fe}_2(\text{SO}_4)_3 = 3\text{Fe}(\text{SO}_4) + 2\text{S}$, yielding ferrous sulphate and free sulphur, also hydrogen sulphide and sulphites may be produced. Ferrous sulphate in solution is a powerful reducing agent and results in many cases in the precipitation of metals, as silver and copper, and as oxides, as cuprite. Many deposits of iron ore have resulted from the interaction of solutions of iron with carbonates, in which the iron has replaced the calcium of limestones and shells. $\text{CaCO}_3 + \text{FeSO}_4 = \text{FeCO}_3 + \text{CaSO}_4$, when siderite and gypsum are formed.

It is by means of a similar replacement or interaction of solutions containing sulphates resulting from the oxidation of sulphides near the surface that such carbonates as smithsonite, rhodochrosite, witherite, cerussite, azurite, and malachite are formed; these minerals may also be formed from solutions of carbonates. The more soluble sulphate gypsum may be replaced by barium, strontium, or lead sulphates. The minerals barite, celestite, and anglesite are often precipitated on the walls of fissures and veins as the result of the intermingling of solutions. Minerals formed by chemical replacement occur usually as lens-shaped masses embedded in the rock which has been the cause of their formation. Large areas of limestone have been changed to dolomite by the replacement of calcium by magnesium. Most of the galena and sphalerite deposits of the Mississippi Valley have resulted from replacements in limestones.

The surface sulphides of many deposits have been completely oxidized. Most of the products of oxidation are carried off in solution; only a small proportion remaining to indicate the nature of the original minerals. The red oxide of iron, hematite, is especially characteristic of such conditions and often covers the lower unoxidized sulphides like a cap; from its position it has been termed the "iron cap." The upper oxidized surface areas of ore deposits are also termed the **gossan**. Minerals characteristic of the gossan are the carbonates, hydrates, sulphates, arsenates, and oxides. The depth of these oxidized minerals, or the gossan, will depend upon climatic conditions, the nature of the formation, and the depth of the ground water. The oxidized areas gradually give way to the region, in ore deposits, termed the areas of **secondary enrichment**, where the sulphides have not only not been oxidized, but have been increased in some of their constituents. The metallic sulphides carried down in solution from the gossan above are precipitated and added to the original metallic content of sulphides beneath. That the waters descending from the oxidized areas above do carry sulphates in solution is abundantly proven by large numbers of analyses of mine waters, and also by the fact that in many mining regions the mine waters carry copper sulphate in such quantities that it pays to precipitate it from the solutions with scrap iron. Of the metallic sulphides, pyrite, marcasite, and pyrrhotite are the most readily oxidized, and when in contact with solutions containing copper sulphate they precipitate the copper as sulphide, forming chalcopyrite. At the Copper Queen Mine, at Bisbee, Arizona, pyrite too poor in copper to pay for smelting was used to fill old stopes, is now, after some ten or twelve years, remined and smelted, having collected nearly 10 per cent. of copper by precipitation from the mine waters through replacement of the iron. Pyrite not only serves as a precipitant for copper, but also for lead, silver, zinc, and other elements less basic.

By this process of oxidation and precipitation the area of secondary enrichment, or the unoxidized sulphides directly underneath the gossan, contains not only the valuable metals which were their original content, but added to this by replacement is a large proportion of that formerly contained in the gossan above. The ore in many mines has been found too poor to work when the regions below the areas of secondary enrichment have been reached. This process is therefore one of prime importance, and must be considered in the valuation of ore deposits. Surface waters and spring

waters are complex solutions of carbonates, sulphates, and chlorides of the more soluble bases, as the alkalies, alkali earths, iron, manganese, aluminium, as well as silica and a large number of other elements in very small quantities. The amount of solid residue in the ordinary natural waters will vary greatly, depending upon the nature of the soil and the geological formations over and through which the waters flow. Rivers of limestone regions are usually high in their content of calcium and magnesium carbonates, as these carbonates are carried into solution as bicarbonates and they are termed hard waters. Such waters are not saturated solutions, containing in solids from 10 to 40 parts to the 100,000, unless greatly concentrated by evaporation or by the loss of carbon dioxide, when the normal carbonates may crystallize or be deposited, as is the case in the formation of stalactites and stalagmites in caves and the calcite cement of some conglomerates. Though the amount of dissolved solids in a river water seems very small, yet when the constant flow is considered, enormous quantities of soluble compounds are carried in solution. It has been estimated that the St. Lawrence at Ogdensburg, New York, having a flowage of 248,518 cubic feet a second, and a salinity of 13.2 parts per 100,000, will transport by this point, annually, 29,278,000 metric tons of salts in solution. Taking into consideration the area drained, exclusive of water areas, this is equal to, if evenly distributed, 102 tons of matter carried off in solution per square mile each year. The volume of the ocean is so great that its saline content is not apparently increased by these enormous quantities of dissolved salts which are being poured into it by every river; but if at any time such waters are confined and evaporation equals or surpasses the annual addition by rivers and rain, the inclosed lake, basin, or arm of the sea will become concentrated, as in the case of salt and alkali lakes of arid regions. When concentration advances to saturation, their salts are usually deposited in a definite order, forming stratified deposits, following the order of saturation in regard to the various minerals separated. There is therefore in such saline deposits an order or sequence from the bottom to the top, except where this order may have been modified by some peculiar local characteristic or condition, caused by an unusual component in the solutions.

When ordinary sea water is concentrated to about one tenth of its original volume, crystals begin to form. In the normal concentration of sea water these crystals are gypsum, and gypsum usually forms the lower stratum of such deposits. Anhydrite may re-

place the gypsum deposit, as gypsum is transformed to the anhydrous sulphate as concentration advances, being induced by a raise of temperature and a concentration of sodium chloride. On top of the calcium sulphate, halite or sodium chloride is deposited, and when finally the mother brines reach the point of saturation for the more soluble sulphate and chloride of magnesium, then double salts are precipitated, as at Stassfurt in Prussia, where some thirty species of minerals have separated from a concentrating brine. Rock salt and gypsum or anhydrite are constant companions, their positions indicating their separation from concentrating brines, though deposits of gypsum will occur without the salt, or it is often interbedded with clay and salt, indicating periods of changed conditions in the concentration of the mother brine caused by an influx of the sea water or by periodic additions of a dilute solution. Often the concentration has never reached the stage when rock salt is deposited, and in such cases the deposit of calcium sulphate will exist unassociated with the usual stratum of halite; or again the salt may have been entirely carried away in solution by the ground water, as salt springs are not uncommon. The minerals of saline deposits include borates, carbonates, chlorides, nitrates, and double salts with various amounts of water of crystallization. They are all quite soluble in water, and as concentration of natural solutions is favored only in very dry climates, they are all characteristic of arid regions.

CHAPTER III

PHYSICAL PROPERTIES

Cleavage and fracture. — When a mineral is broken by the blow of a hammer on a sharp-edged instrument, as a cold chisel, held on the specimen, it either breaks in a smooth plane face or irregularly. The former is **cleavage**; the latter is **fracture**. Cleavage is caused by the separation along and between layers of molecules. Taken in this sense, only crystalline minerals may possess cleavage.

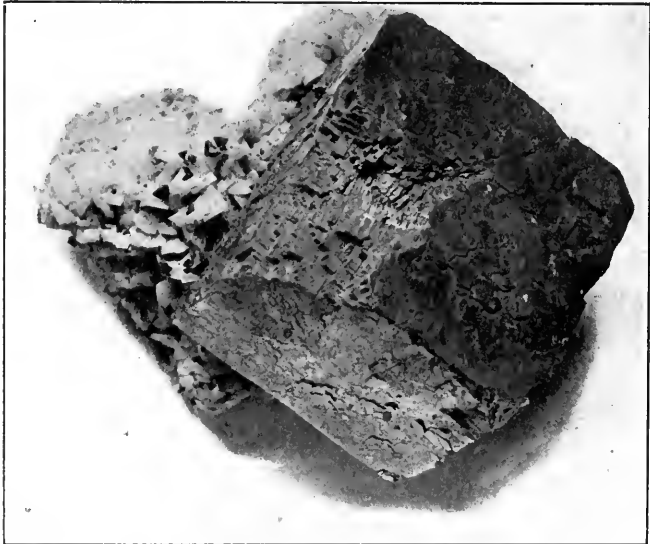

FIG. 371.—A Crystal of Galena, showing the Perfect Cubical Cleavage. Aurora, Missouri.

Cleavage is named from the crystal form to which the separation is parallel, and is represented by the letter representing the form, as cleavage **m** = prismatic or parallel to the unit prism, **c** = basal, etc. Galena and halite have cubical cleavage, Fig. 371; calcite, rhombohedral; spodumene, prismatic, etc. A perfect cleavage is one in which the plane face obtained is smooth, even, and polished and is generally easy to obtain but not necessarily so;

such a cleavage is the cubic cleavage of galena, in which it is almost impossible, even on grinding, to obtain particles not cubical in form. Cleavage faces may be highly polished and smooth, even though difficult to obtain, as the rhombohedral cleavage of quartz.

Cleavage surfaces parallel to the faces of the same crystal form are all of the same character; they possess the same luster and are obtained with the same ease, as the three directions of the rhombohedral cleavage in calcite, or the four directions of the octahedral cleavage of fluorite. In anhydrite, where there are also three cleavage directions at right angles, they are obtained with unequal ease and each differs from the other in luster. In gypsum there is one very perfect cleavage, parallel to the clinopinacoid, cleavage **b**, and another parallel to the orthopinacoid, cleavage **a**, which is obtained with more difficulty; the resulting flat cleavage plates are parallel to the easy clinopinacoidal cleavage, and are bounded by two straight edges parallel to the less easy orthopinacoidal cleavage. This is also the usual shape of cleavage fragments in orthoclase. The comparative ease of coexisting cleavages materially influence the general shape of the fragments into which a mineral breaks. The descriptive terms as applied to cleavage are: **perfect**, as the rhombohedral cleavage of calcite; **distinct**, as the prismatic cleavage of rutile; **imperfect**, as the basal cleavage of beryl or apatite; **traces** or **indistinct**, as the cubic and octahedral cleavage of pyrite; **difficult**, as the cleavage of quartz or tourmaline.

When the cleavage pieces are flat and it is possible to cleave very thin laminæ, the cleavage is said to be **micaceous**, as in muscovite or biotite. The laminæ are described as **flexible** when they can be bent, even though they may crack, but without parting, as in chlorite; **elastic** when they bend with an even curve without cracking and on being released spring back to their original flat condition, as in muscovite. The laminæ are **brittle** when they break easily on bending, as in margarite; **tough** in one direction and brittle in another, as in gypsum.

Parting is not a true cleavage, but is the result of pressure or strain to which minerals have been subjected and is therefore not characteristic of all specimens of the same species, but is peculiar to localities and formations and not necessarily confined to crystals. Some garnets have a parting parallel to the rhombic dodecahedral faces, others have no indication of it. Magnetite and franklinite have an octahedral parting.

Fracture is where the specimen breaks, not along a smooth plane face, but irregularly in no definite direction. The appearance of the uneven surface of fracture is also characteristic, and the following terms are used in describing the fracture of minerals: **Conchoidal**, when the break results in curved or warped surfaces, as in glass, chrysocolla, or flint, Fig. 372. **Subconchoidal**, when the curves are not well marked, are uneven, and the surfaces are slightly rough, as in most minerals. **Hackly**, when the roughness consists of sharp points, as in copper and most metals. **Splintery**, when the fracture



FIG. 372.—Obsidian, showing a Conchoidal Fracture.

shows a fibrous structure, as in some steatites. **Scaly**, where the mineral is formed of fine crystal scales, as in lepidolite.

Tenacity and hardness both depend upon cohesion. The force necessary to overcome this attraction of one molecule for its neighbor will vary with the molecule and the direction in the crystal.

A **sectile** mineral may be cut with a knife, and the shavings remain whole and possibly curl like the shaving of a quill or horn, as graphite, molybdenite, and most micas and metals.

A mineral is **malleable** when it flattens on hammering and spreads out, increasing in area without cracking, as lead, silver, or tin; **ductile** when it may be drawn out in wire, as copper, silver, iron; **brittle** when on hammering it breaks down in a powder as do most minerals, — though the ease with which this occurs is modified by such terms as **tough**, as rhodonite; **soft**, as wad; **friable**, as kaolinite.

Hardness is an uncertain term, but in mineralogy it may be taken to indicate the ease or difficulty with which a mineral may be scratched. It is a directional quality and not only varies with the crystal form, but with the direction on the same crystal face. The hardness of cyanite when tested on the macropinacoid parallel to the vertical axis is 4-5, but tested on the same face at right angles to this direction it is nearly 7. When the **hardness** is tested in all directions on a face like that of cyanite, and the values plotted in a curve, this curve will be found to conform to and reflect the symmetry of the face, Fig. 373.

Where it is wished to determine the hardness with some degree of accuracy, the **sclerometer** is used, the principle of which depends upon weighting a sharp point of a very hard substance, as a pointed diamond, until it just scratches the

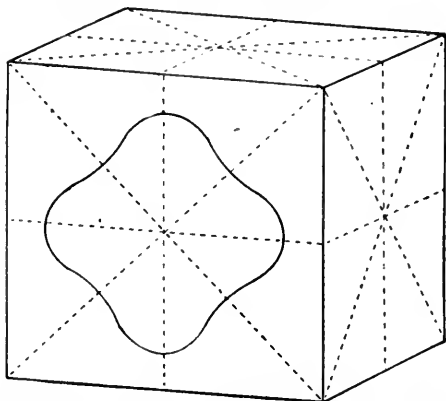

FIG. 373.—Curve of Hardness on the Cube Face of Fluorite.

surface of the specimen when drawn across in any particular direction in which the hardness is wished to be determined. The weight of the load which just produces a scratch is taken as a measure of the hardness. Again, the material removed by the point under a constant load after being drawn across the face a determined number of times may also be taken as a measure of the hardness, but here the hardness will be inversely as the weight of material removed. The loss of weight or the material removed is determined by weighing the crystal.

Hardness as a test in the identification of mineral species is determined by reference to a series of minerals arranged in a table, in ascending scale, from 1, the softest, to 10, the hardest. The series of ten test minerals is known as Moh's scale of hardness, a purely arbitrary scale and in no way representing the true relation, as the difference between 9 and 10 in the scale is ever so much greater than the difference between 1 and 2. Moh's scale of hardness below is also expressed in terms of hardness as determined by the sclerometer, in which the hardness of the sapphire is taken as 1000.

1. Talc	1.13	6. Orthoclase	191
2. Gypsum	12.03	7. Quartz	254
3. Calcite	15.3	8. Topaz	459
4. Fluorite	37.3	9. Sapphire	1,000
5. Apatite	53.5	10. Diamond	140,000

The specimens used for the scale should be crystalline, cleavable, and as nearly transparent as possible.

In testing a mineral for hardness, a sharp point of the mineral in the scale or test mineral is pressed firmly on a smooth surface of the mineral to be tested and drawn across with a quick movement. The harder the mineral the more pressure will be required to make the scratch. Care must also be taken not to mistake the mark left by a soft mineral on a harder surface as a scratch. This mark, like a chalk mark, may be easily rubbed off, while a scratch may be tested by drawing the finger nail across it. Minerals of the same hardness will scratch each other when tested in this way.

In ordinary cases, as the determination of hardness for use with the blowpipe tables, hardness above or below 3, 5, and 7 is an important point. If a mineral will scratch a copper coin, it may be considered as above 3 in hardness, and failing to scratch glass it would be below 5; failing to scratch quartz and scratching glass, it would be between 5 and 7 in hardness. With experience the approximate hardness of a specimen may be determined by the ease or difficulty with which it is cut or scratched by an old knife-blade or file. When the knife fails to have any effect on the specimen, it is above 6 in hardness. In testing the hardness of a mineral, care must always be taken that it is as pure as possible and free from decomposition products, remembering that impurities, as sand, etc., will cause a soft mineral to appear much harder than in reality it is, and by decomposition minerals which when unaltered are very hard, as corundum or andalusite, will appear softer.

Specific gravity = G, is the expression in figures of the ratio of the weight of unit volume of the substance to the weight of unit volume of water at 4° C. A mineral in which $G = 2.65$ (quartz) will weigh 2.65 gm. per cubic centimeter, since one cubic centimeter of water weighs one gram. Knowing the specific gravity of any mineral or rock, it is an easy matter to determine the weight of any cubic amount, as a yard or a foot. For the identification of minerals, the specific gravity is determined approximately to the second

decimal place. Various specimens of the same species will differ according to their purities, but chemically pure specimens of a substance determined under the same conditions will not vary in their specific gravity.

The specific gravity of most minerals, including most of the silicates, will lie between 2.25 and 3.5. Minerals with metallic luster are usually high and will lie between 4.5 to 10, while the specific gravity of the naturally occurring metals reaches as high as 23 in iridium. The specific gravity of ice is 0.92.

Two general methods are followed in the determination of the specific gravity: (a) weighing the substance in air and weighing it in water; (b) suspending the substance in a liquid of the same specific gravity, then determining the specific gravity of the liquid by weighing.

(a) There are several modifications of this first method, depending upon the accuracy required, or the solubility and physical condition of the material.

I. Joly balance. — A quick but only an approximate method. The balance, Fig. 374, consists of a spiral spring **S**, two scale pans **P** and **P'**, a long mirror graduated in units and tenths, a white bead **b**, just above the top scale pan, to assist in reading the scale, and a movable bracket, which supports a beaker of water. If it is wished to determine the specific gravity of a crystal of quartz, as an example, three readings are necessary, and in each reading the lower glass scale pan **P'** should be submerged to the same depth in the water, should not touch the walls of the beaker, and should be free of air bubbles. The first reading is taken with both pans empty and the lower one submerged in the beaker of water; the eye is held in such a position that the bead **b** will exactly cover its image in the mirror = **C** = 2.8 in this case. The specimen is now placed in the top pan **P**, care being taken that with the extra weight it does not sink in the water and get wet, increasing its weight; the beaker is now lowered until the pan **P'** rests at the same depth in the water as before, when the second reading is taken = 16.1. The specimen thoroughly wet is now placed in the

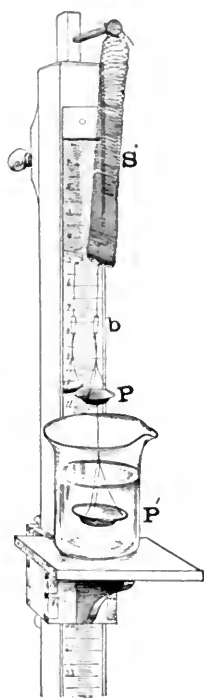

FIG. 374. — Joly Balance.

lower pan P' . There should be no air bubbles sticking to it; the beaker is now raised until equilibrium is established, with the lower pan at the same depth in water as before, when the third reading is taken = 11.1. To determine the specific gravity:

$$G = \frac{\text{the weight in air}}{\text{loss of weight in water}} = \frac{W}{W - w} = \frac{16.1 - 2.8}{16.1 - 11.1} = \frac{13.3}{5} = 2.66.$$

The specific gravity of pure quartz is 2.653. In this method the specimen used should weigh between two and three grams. The chemical balance may be substituted for the Joly balance and accurate weighings made, with a resulting increase in accuracy.

II. Pycnometer method. — The pycnometer, Fig. 375, is a small flask of usually 10 cc. capacity, having a nicely fitted ground glass stopper with a capillary bore running through it. The weight of distilled water which exactly fills the pycnometer at 20° C. is determined once for all = C . In each case the pycnometer is weighed empty and dry = P . The specimen is powdered to avoid any internal cavities and about two and one half grams are placed in the pycnometer, it having been dried at 100° C. when there is no danger of loss at that temperature, and carefully weighed = S . The pycnometer is now filled about half full with distilled water and very carefully boiled for a few minutes to expel any



FIG. 375. — Pycnometer.

air that may be included in the powder. After cooling, the flask is filled with recently boiled distilled water, care being taken that none of the sample is lost and that the pycnometer is filled to the top of the small capillary bore when the stopper is in place, and cooled to 20° C., when the whole is weighed = D . S = sample and pycnometer weighed together.

$$\begin{aligned} S - P &= W = \text{weight of sample in air.} \\ (S + C) - D &= \text{loss of weight in water.} \end{aligned}$$

$$G = \frac{S - P}{(S + C) - D}.$$

When all precautions are taken, this method will yield results accurate to ± 1 , in the fourth decimal place.

When the substance is soluble in water or affected by water, some other liquid than water is used the specific gravity of which has been determined, as benzene or carbon tetrachloride. The experiment is carried out as with water, but the result must be multiplied by the specific gravity of the fluid used in order to reduce it to terms of water as the unit.

III. The suspension method. — The Westphal balance and the use of heavy liquids. The advantage of this method is that the gravity of small crystals or fragments may be determined with accuracy to the third decimal place as in the pycnometer method. The method consists in placing the fragment in a liquid, the specific gravity of which is higher than that of the fragment, which will then float on the surface of the heavy liquid.

The fluid is now diluted carefully with a lighter one, stirring after each addition; a point will be reached when the fragment of mineral will neither float nor sink; the specific gravity of the liquid and fragment are under these conditions identical and the fragment remains suspended. The specific gravity of the fluid is now determined with the Westphal balance or the pycnometer when accuracy is required.

The heavy solutions in general use are :

Thoulet's solution. — A solution of potassium iodide, KI, 1 part, and mercuric iodide, HgI_2 , 1.24 parts, dissolved in an excess of distilled water. The solution is then evaporated on the water bath until a fragment of fluorite floats on it; on cooling, the gravity rises to the maximum 3.196. It is then filtered, and well corked, as on exposure to the air it absorbs water and its specific gravity will fall to 3.1, where it remains constant. It is a convenient solution, as it may be diluted with water to any extent, and if left standing exposed, the water will evaporate until the specific gravity reaches 3.1; by evaporation on the bath it may again be brought back to 3.196. If darkened by the separation of iodine, this may be corrected by adding a little mercury during the evaporation. Methylene iodide, CH_2I_2 , $G = 3.315$ at 20°C , is a little heavier than Thoulet's solution, but has the disadvantage of not being miscible with water, and benzole must be used to dilute it. It does not attack metals as does the mercury solution.

The heaviest solution of all is that suggested by Penfield, silver thallium nitrate, which is liquid at 75° and has a specific gravity of 4.5 and may be diluted with water.

Where only an approximate determination is all that is required, as in the identification of minerals, the fragment is placed on the liquid, and the liquid is diluted until suspension is reached, then small fragments of minerals, the specific gravity of which are known, are used as tests. Thus if calcite sinks and quartz floats, the specific gravity of the mineral to be determined must lie between 2.65 and 2.72 or not far from 2.70.

A list of convenient test minerals is as follows :

Heulandite	2.20	Calcite	2.72
Analcite	2.26	Prehnite	2.87
Gypsum	2.32	Datolite	2.95
Leucite	2.47	Tremolite	3.00
Orthoclase	2.56	Actinolite	3.10
Quartz	2.65	Fluorite	3.18

When accuracy is required the Westphal balance, Fig. 376, is used. This consists of a bob *n* which just balances the arm *H* in air. The arm is divided into a decimal scale. Three sizes of weights are furnished with the instrument, *A* = units, *B* = .1 and *C* = .01, when hung on the hook as *A*², and corresponding tenths of these values when on the arm.

In the determination, the bob is immersed in the liquid and the balance arm weighted to balance, when the specific gravity is read directly from the weights and the arm.

The separation of minerals with heavy solutions. — The different mineral components of a rock such as granite may be separated by the use of heavy liquids. The specimen is ground only sufficiently fine to insure each particle as consisting of one mineral species only; the fineness necessary is determined by an examination of the powder with a microscope. The sample is then charged in chamber *A* of the separatory apparatus, Fig. 377, and Thoulet's solution, density 3.00, poured in, stoppered and shaken; all accessory minerals, as zircon, apatite, magnetite, amphibole, and tourmaline, will settle in the chamber *A*, while the others will float on the surface of the liquid. The heavy minerals may, after settling, be drawn into *B* by means of the cock *C*, and finally after shaking a second time, out at the bottom by turning the cock *C'*. The solution in chamber *A* is now diluted until calcite just sinks, when it is again shaken, allowed to settle, and all minerals above 2.72, as the micas, are drawn off. The solution in *A* is again diluted until quartz just sinks, which is separated from the orthoclase.

Where samples for analysis are required it is advisable to pass the material through the separator several times, care being taken

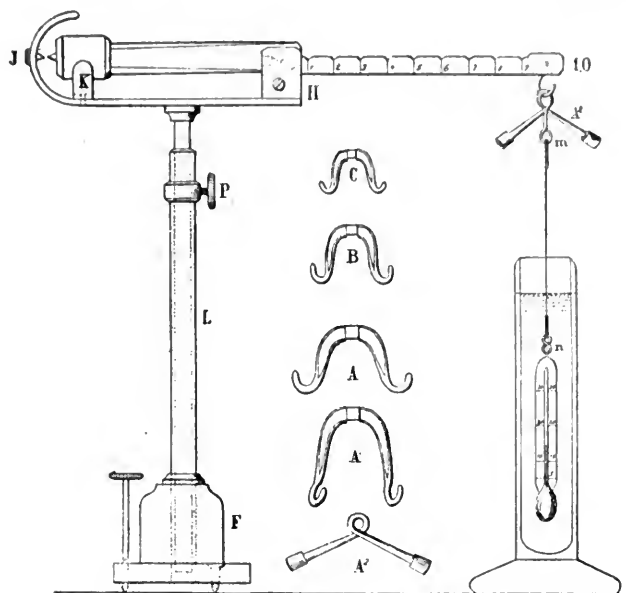

FIG. 376. — The Wesphal Balance.

to have the specific gravity of the heavy liquid nicely adjusted to the specific gravities of the minerals to be separated.

Terms used in the description of mineral aggregates. — Individual crystals, even though of the same species and combinations of the same forms, may differ greatly in appearance. The general shape of a crystal will depend upon the crystal form which predominates in the combination; thus various habits arise which are described by the following terms:

Tabular is when a pair of parallel faces, as the base or pinacoid, predominate. The crystal is short in one direction and extended in the other two, as in some barites, tabular parallel to the base, Fig. 378.

Prismatic is when the individuals are elongated in the direction of any one axis, usually the vertical axis, as in quartz.

Short and stout prismatic crystals are said to be of columnar habit, as beryl.



FIG. 377.

Acicular is where the prismatic habit is so accentuated that the crystals are long and needle-like, as stibnite or rutile.



FIG. 378. — Tabular Barite and Acicular Stibnite. Felsöbanya, Hungary.

When still more attenuated or hairlike, they are said to be capillary, as millerite, Fig. 379.

Fibrous is when the fine hairlike crystals are parallel in arrangement, and usually easily separable, as asbestos, Fig. 380.



FIG. 379. — Millerite. Antwerp, Jefferson County, New York.

All the above habits may be illustrated by specimens of the same mineral species.

The surfaces of crystal faces and mineral aggregates differ in appearance and the following descriptive terms are in use:

Striated. — Crystal faces are often crossed by striations, which are always parallel to some definite crystallographic direction and

often serve for the identification of zones or individual forms. They are of two varieties: those caused by alterations of growth, between two crystal forms and therefore parallel to their intersection or edge, as the horizontal striations on the prism faces of quartz.

When the striations are very marked, the crystal is said to be **furrowed**. **Twinning striations** differ from oscillatory striations, or those caused by the alterations in growth between two forms, in that they represent the composition plane between twins which



FIG. 380. — Asbestos. Thatford, Quebec, Canada.

penetrate and pass through the body of the crystal. They will therefore appear on cleavage pieces as well as on crystal faces, either singly, as in the Alaska epidotes, or often repeated as parallel lines, as in the plagioclases.

Vicinal faces. — It has often been observed that each face of a simple form, which may be represented by parameters or indices of normal value, as the cube or octahedron in the isometric system, is replaced by a low and very flat pyramid. The number of faces of the pyramid will depend upon the symmetry of the face replaced — in the cube four and in the octahedron three. These flat vicinal faces intersect the axes at long distances and their indices, contrary to the general rule of simple indices, are large and indefinite, though the faces conform to the symmetry of the type

and represent always the more general form of the type. Vicinal faces are common on fluorite, where the face of the cube seems to be replaced by a very flat tetrahedron, Fig. 381.



FIG. 381.—A Cube of Fluorite, showing Four Vicinal Faces replacing the Cube Face.

When a zone of vicinal faces occurs, the crystal appears rounded or bounded by curved faces.

Drusy.—A surface formed of numerous small individual crystals and therefore dull is said to be **drusy**. Drusy surfaces may be caused by a secondary mineral produced by surface decomposition, or it may be the result of very fine crystals usually in parallel position, representing a second generation of the same species;

or it may be caused by a parallel or radiated aggregate of fine crystals, each terminated at the surface, as in crusts of millerite or smithsonite.

Internal structures.—**Granular** is where the individual crystals



FIG. 382.—Calamine with Radiated Structure. Franklin, New Jersey.

are equidimensional and irregularly packed together, the individuals being distinguishable by the unaided eye.

Massive or compact.—A granular structure in which the individuals are not to be distinguished by the unaided eye.

Powdery. — Is when the fine individuals are easily parted and break down under slight pressure.

Lamellar. — Is when the individuals are flattened and in parallel position and easily parting, as some tale. Foliated is an equivalent term, only the laminae are thicker.

Radiated. — Formed of individual crystals, usually acicular, which radiate from a point, the nucleus of crystallization, like the sticks of a fan. Sometimes termed **fan-shaped**, as calamine or wavellite, Fig. 382.

Reticulate. — Individual prismatic crystals arranged like lattice-work, with definite twinning angles, as the rutile from Tavetsch,

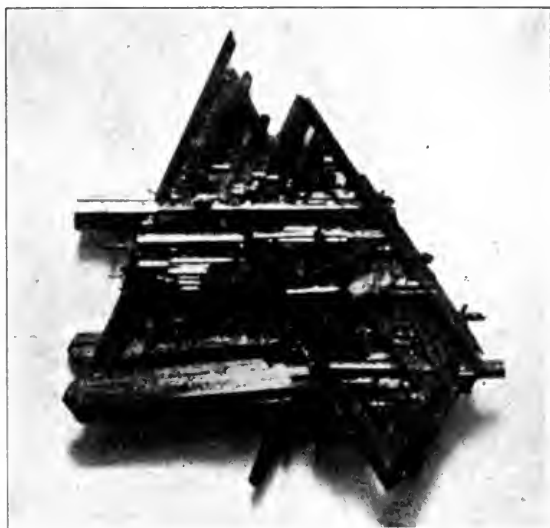

FIG. 383. — Reticulate Rutile, enlarged. Tavetsch, Switzerland.

Switzerland, Fig. 383, or irregularly matted, as the cerussite from Cornwall, England.

Dendritic. — Branching forms deposited from solutions, in cleavage cracks and rock fissures, as pyrolusite or metallic copper, Fig. 384.

Wiry. — Like wire, usually native metals, as silver or gold, also in sheets or leafy.

Nuggets. — Are irregular rounded or rolled lumps, usually applied to the precious metals, as gold, silver, or platinum, Fig. 385.

Nodular. — Applies to rounded individual masses of minerals; as the rounded balls of pyrite occurring in some clays, Fig. 386.

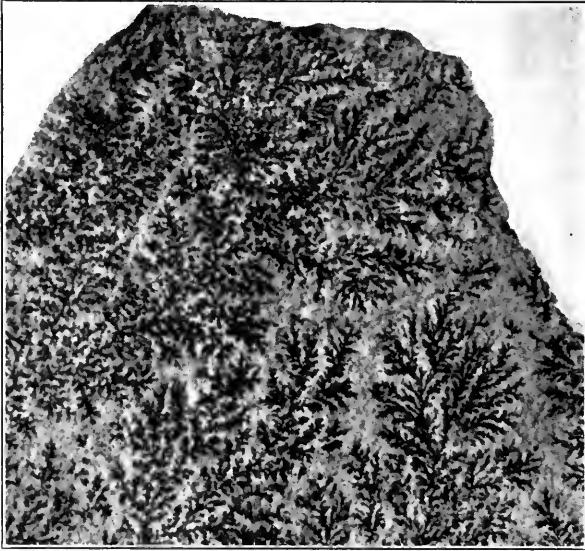

FIG. 384. — Dendritic Psilomelane. Leadville, Colorado.

Geodes. — Are cavities in clays or other formations, which have been encrusted with a wall of quartz or other mineral, and which



FIG. 385. — Platinum Nugget. Nischi-Tagilsk, Siberia.



FIG. 386. — Nodular Pyrite.

separate as a hollow mass, the interior walls of which are usually studded with crystals, Fig. 387. Small almond-shaped steam cavities occurring in lavas are often filled by minerals, deposited from

solution; such bodies of minerals are termed **amygdules** and the structure **amygdaloidal**.



FIG. 387. — Geode studded with Quartz Crystals.

Pisolitic. — Spherical forms with concentric shell-like structure, as in some calcites from Freiburg, Saxony, Fig. 388. When the individual spherules are small, the mass resembles fish roe, or **oölitic**.



FIG. 388. — Oölitic Calcite. Carlsbad, Bohemia.

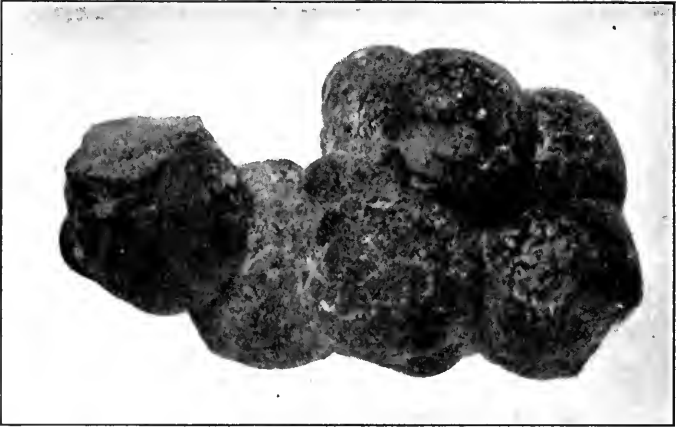

FIG. 389. — Botryoidal Prehnite. Bergen Hill, New Jersey.

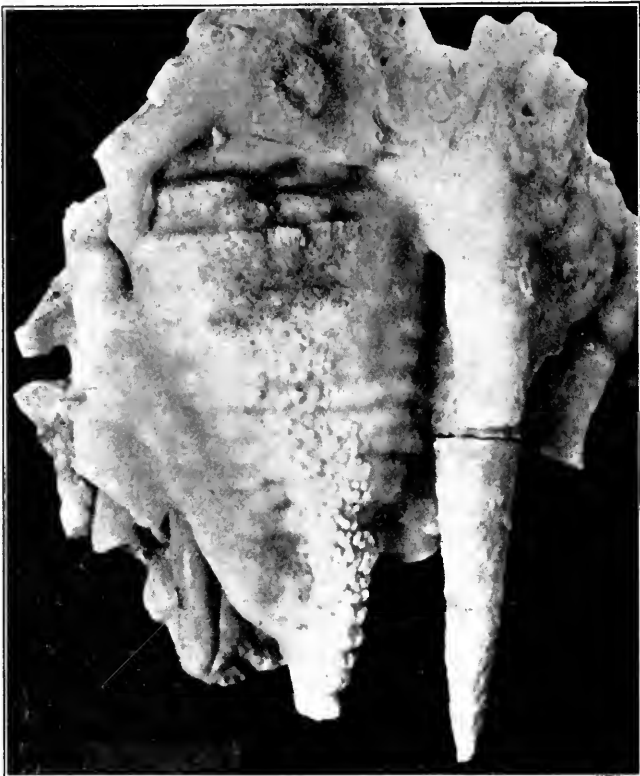

FIG. 390. — Stalactite of Calcite. Copper Queen Mine, Bisbee, Arizona.

Botryoidal. — When in rounded irregular masses, usually with a smooth surface and an internal radiated structure, as prehnite, Fig. 389. When in forms resembling kidneys, often termed reniform, as some hematites.

Stalactitic. — Minerals are often formed by the evaporation of solutions dripping from the walls and ceilings of caves; the solids are deposited in the form of icicles or stalactites, as calcite, malachite, or limonites, Fig. 390. Stalactites are often long, slender, and hollow, the solution flowing down the hollow tube and deposit-



FIG. 391. — Stalagmite of Calcite.

ing the mineral substance only on evaporating at the lower end. Such stalactites are **strawlike**.

Stalagmites. — Are the reverse of stalactites, or the structure which forms on the floor of caves under the drip from a stalactite, Fig. 391.

Mammillary. — When the crusts are composed of rounded masses or nipple-like structures.

Other terms in common usage in the description of minerals will need no particular explanation.

Color of minerals. — The outward appearance of minerals, due to other causes than form or structure, is caused by light, or **color** and **luster**. The color of a specimen when opaque is caused by reflected light wholly; when transparent, to transmitted light in combination with reflected light. When white light falls upon a mineral, some rays are absorbed and the complementary color is

reflected as the color of the surface, while the depth or tone is modified by the physical condition of the surface, for a highly polished surface will glisten with the quantity of light reflected, and a rough, earthy, or powdery surface will appear dull from the amount of light diffused. Combined with these surface effects, in transparent minerals, is the color of transmitted light, characteristic in some cases, as in crocoite, of the compound, in others, as in quartz, due entirely to impurities.

Since the nature of the surface is variable, it has been found more accurate in comparing the color of mineral specimens to use the very finely ground powder, which insures a surface always of the same nature, from which the same amount of light will be reflected or diffused, and the color will not depend upon fortuitous causes. The most convenient method of obtaining the fine powder quickly is to draw, with a firm pressure, the rounded corner of the specimen quickly across an unglazed porcelain surface, when most minerals will leave a mark, termed the **streak**, the color of which is that of the fine powder. The color of the streak is of great help in the rapid determination of minerals. The streak is little affected by the structure of the specimen, as hematite occurs in well-formed crystals, micaceous, compact, massive, and earthy, with a blood-red color, gray, steel-gray to nearly black, iridescent, or brown; all of these varieties will yield a cherry-red streak.

A mineral is described as of **metallic luster** when the streak is dark in color and the specimen is opaque on the thin edges or in thin sections and has a shiny surface, common to most metals, as tin or iron. When the streak is dark and the surface is not shiny, it is of **submetallic luster**.

If the streak is light in color or the thin edges and sections transmit light, it is **non-metallic** in luster.

The color of metallic and submetallic minerals is more characteristic and less variable than in non-metallic. It is therefore more reliable as a means of identification.

The true color of a mineral is shown only on a freshly broken surface, as by oxidation or weathering the natural surface may be entirely changed. The beautiful iridescence of some pyrites, chalcopyrite, limonite, and hematite, is caused by a thin film of oxides or hydroxides which yield spectral colors through the interference of light.

The surface change in color due to chemical change is termed

tarnish. Non-metallic minerals are transparent on thin edges or in thin sections, such as rock sections, which are under .04 mm. Many minerals which are opaque in coarse fragments, as the black tourmalines or rutile, will be transparent in thin sections; even metals, as gold, will transmit light if the sheets are thin enough. The opacity to light is relative, depending upon the thickness of the section. A mineral is said to be **transparent** if the outline of objects can be distinguished through it; **translucent** when the light is diffused and the outlines of objects are no longer distinguishable through the specimen. Some effects are due to both diffusion and interference of light, as opalescence, and the milki-ness of some quartz, the play of colors in the fire opal, or the color yielded by some labradorite when viewed at certain angles with the twinning planes. The star sapphires and cat's-eye are due to reflections and a fibrous structure. The prism colors or banded effects produced by films of air in thin cleavage cracks are due to interference.

The variability of color in non-metallic minerals is well illustrated in quartz, a mineral which, when pure, is colorless. Very small amounts of some oxides which are present as impurities act as a pigment, yielding decided colors even when the amount of coloring material is so small as not to be detected by the ordinary chemical tests.

Certain colors are characteristic of chemical elements, as most copper minerals are blue, green, or red; and copper compounds will yield these colors when present in other minerals as impurities or inclusions. Calcite, smithsonite, and quartz are often colored green by copper compounds. Chromium yields a green color, as in the green of some garnets and in the emerald. The red of the ruby as well as the red of crocoite is chromium in a different form or ion. Nickel also yields a green color, as in chrysoprase, a variety of quartz. Iron as an impurity will yield shades of red, brown, yellow, green, or blue according to its state of oxidation or combination. The yellow calcites of Joplin, Missouri, contain ferrous iron carbonate and the red jaspers and bloodstones are colored by ferric iron. Very small quantities of manganese yield intense colors; pinks, amethystine, and some greens are caused by manganese. The rose color of some quartz and tourmaline is caused by titanium, which also when in a lower state of oxidation will yield a blue. Cobalt is the most intense of all mineral pigments and many blue minerals owe their color to cobalt; when in cobaltic form, the ion is

pink, as in cobalt bloom. Uranium minerals are yellow or green. Molybdenum yields greens and yellows, and tungsten yellow or blue; while the browns and yellows of most quartz, as smoky quartz, are caused possibly by organic matter, and the delicate blues, violets, greens, and yellows of fluorite, apatite, barite, and topazes are also attributed to organic matter.

Inclusions of colored minerals within the body of a colorless mineral are often the cause of color in minerals, as the red or flesh-



FIG. 392. — Section of Tourmaline, with an Uneven Distribution of Color. Brazil.

colored orthoclases of some granites is caused by included scales of hematite, as is also the peculiar appearance of aventurine quartz.

The color of minerals caused by pigments is not always evenly distributed, as during the period of growth of some crystals the chemical composition of the mother solution may have changed as regards these minor constituents, resulting in the change of color of the forming crystals, producing **phantoms** or outlined crystals within the body of larger individuals, as the phantom amethysts of Schemnitz, Hungary, and the phantom fluorides of Cumberland, England. The best illustration of the uneven or irregular distribution of color is the variegated tourmaline of many localities, as of Haddam, Connecticut; Pala, California, or Brazil. In the latter the colors appear in concentric bands as illustrated in the section,

Fig. 392, at right angles to the vertical axis of a tourmaline from Brazil. In the center there is an area of concentric bands of different shades of pink, then a colorless band, outside of which is a band of green. Again the colors may be distributed lengthwise the crystal, as many specimens from Mesa Grande, California, in which one end may be green, the other pink, and often separated by a colorless middle band across the body of the crystal.

The delicate coloring of some transparent crystals is often changed by heating; in this way the pink topazes are produced by heating the originally yellow stones from Brazil. This process is known as "pinking," and if the heat is too great, the crystal becomes colorless.

In the description of colors in minerals Werner, nearly two hundred years ago, fixed the following eight colors as primary, and since that time mineralogists have been accustomed to describe minerals in terms of these eight colors with their variations as follows:

WHITE, either clear, transparent, or translucent

Snow-white, as Carrara marble.	Greenish white, as talc.
Reddish white, as some calcite.	Bluish white, as some calcite.
Yellowish white, as some calcite.	Milk-white, as some quartz.
Grayish white, as some calcite.	

GRAY

Blue-gray, as some wernerite.	Yellowish gray, as some dolomites.
Pearl-gray, as some dolomites.	
Smoke-gray, as flint.	Ash-gray, as leucite.
Greenish gray, as tremolite.	

BLACK

Grayish black, as ilvaite.	Brownish black, as allanite.
Velvet-black, as black tourmaline.	Reddish black, as acmite.
Greenish black, as augite.	Bluish black, as tourmaline (indicolite).

BLUE

Blackish blue, as dark azurite.	Prussian blue, as eyanite.
Azure-blue, as light azurite.	Smalt-blue, as dumortierite.
Violet-blue, as some fluorites.	Indigo-blue, as some vivianites.
Lavender-blue, as some sodalites.	Sky-blue, as turquoise.

GREEN

Verdigris-green, as amazon stone.	Olive-green, as olivine.
Celandine-green, as some beryl.	Grass-green, as some diallage.
Mountain-green, as light beryl.	Pistachio-green, as some epidote.
Leek-green, as prase.	Black-green, as some serpentine.
Emerald-green, as emerald.	Oil-green, as some beryl.
Apple-green, as chrysoprase.	Siskin-green, as torbernite.

YELLOW

Sulphur-yellow, as sulphur.	Ocher-yellow, as some limonites.
Straw-yellow, as yellow topaz.	Wine-yellow, as topaz.
Wax-yellow, as orpiment.	Cream-yellow, as some kaolinite.
Honey-yellow, as some blende sphalerite.	Orange-yellow, as some orpi- ment.
Lemon-yellow as sulphur.	

RED

Aurora-red, as realgar.	Carmine-red, as ruby.
Hyacinth-red, as crocoite.	Rose-red, as rose quartz.
Brick-red, as some jasper.	Crimson-red, as ruby.
Scarlet-red, as cinnabar.	Peachbloom-red, as erythrite.
Blood-red, as pyrope.	Flesh-red, as some feldspars.

BROWN

Reddish-brown, as zircon.	Pinchbeck-brown, bronzite.
Clove-brown, as axinite.	Wood-brown, as some asbestos.
Hair-brown, as some wood opals.	Liver-brown, as some jaspers.
Chestnut-brown, as some hema- tites.	Blackish brown, as some chromites.

Luster.—Luster is a term used to describe or denote the peculiar character of light reflected from the surfaces of minerals. The difference in quality of reflected light is caused not only by the character of the surface, but also by the structure and index of refraction of the specimen. All faces of the same crystal form, as the cube faces or cubical cleavage surfaces of galena, will have the same luster, while the three pinacoids are at right angles to each other, as the three directions of the cubical cleavage, but each of the pinacoids may have a distinguishing luster.

In addition to metallic, submetallic, or non-metallic lusters, which are in a large measure dependent upon opacity to light, the following terms are used: **Adamantine** luster is a high, shiny, and brilliant luster, usually connected with minerals with a high specific gravity and index of refraction. It also gives the impression of being very hard. Good examples are cuprite, rutile, cassiterite, sphalerite, cerussite, and diamond.

Vitreous or glassy luster, as of broken glass, bright and shining, like quartz, apatite, beryl, and most of the silicates.

Greasy or resinous is a vitreous luster as if oiled or like resins, as serpentine.

Waxy, very much like resinous, like calcedony.

Pearly luster is well shown in mother-of-pearl, due to a combination of surface reflection and a shelly structure, as in brucite, talc, and the basal cleavage of apophyllite and the pinacoidal cleavage of heulandite.

Silky luster is the luster of satin, due to a fibrous structure, as in satin spar, asbestos, and enstatite.

Dull, as in chalk or kaolinite, is where the reflected light is diffused.

Phosphorescence. — Some minerals and chemical compounds possess the property of transforming energy of other forms into light and continue to emit a characteristic glow long after the exciting agent or cause has been removed or ceased to act. Calcium sulphide mixed with small amounts of bismuth is used as a luminous paint and will continue to glow for hours after exposure to sunlight. The hexagonal zinc blende, wurtzite, will glow under the emissions of radium. Diamonds, willemite, and kunzite phosphoresce when exposed to the Röntgen ray or ultra-violet light. In the case of willemite the ultra-violet light is used to test the completeness of the mechanical separation from the gangue and other zinc minerals, as every remaining particle of willemite will glow brilliantly when exposed to ultra-violet light.

Other minerals, as quartz, become luminous by friction, or when fractured, as some micas. Specimens of the same species may vary greatly in their power to phosphoresce and it would seem not to be a property of pure chemical compounds or pure minerals but is caused in most cases by impurities and is often restricted to localities, as all the minerals from Borax Lake, California, phosphoresce under ultra-violet light, which is probably due to some common constituent.

Phosphorescence is caused by the lengthening of the wave of the absorbed energy, as the ultra-violet wave and the wave of the Röntgen ray are too short to be detected by the eye, but when lengthened to .00039 mm. affect the eye as light.

Fluorescence is much like phosphorescence, only the phenomenon continues during the actual exposure only, as in the barium platinumocyanide screen, used to visualize the Röntgen rays. Some white fluorites fluoresce in the sunlight with a bluish, milky, or hazy light. This is a property possessed by uranium compounds and some compounds of boron. Uranium nitrate is used in the manufacture of fluorescent glass.

CHAPTER IV

THE NATIVE ELEMENTS

DIAMOND

Diamond. — Carbon, C; Isometric; Type, Ditesseral Polar; Common form, o (111); Twinning planes, 111 and 100; Cleavage octahedral, perfect; Brittle; Fracture, conchoidal; H.=10; G.=3.51 – 3.52; Color, white, yellow, brown to black, rarely blue or green; Luster, adamantine to slightly greasy; Transparent to opaque; $n=2.42$; Dispersion strong =.063.

B.B. — Infusible, insoluble in acids. When heated to a high temperature for a long time it burns slowly, forming CO_2 . Colored stones may change color on heating.

General description. — Always crystalline, usually simple octahedrons or rounded hexoctahedrons which are supplementary twins, combinations of the plus and minus hextetrahedrons, in which the octahedral edge is replaced by a reëntrant angle. Simple tetrahedral forms and the cube are rare. Crystal faces are often drusy or covered with triangular etch-figures, due to corrosion, which is also the cause of the rounded appearance of many diamond crystals. Twins after the spinel law, where the face of the octahedron is the composition plane, are not uncommon.

The perfect octahedral cleavage is utilized by the cutters in the rough preparation of the stones for the grinders. While the diamond is the hardest known substance, it is brittle and easily broken or ground to powder, the dust of which is used on the wheels or "skeifs" in grinding and polishing the facets of the cut stone. The inclination of all facets of the brilliant is calculated so that the greatest amount of light is totally reflected and returned. Owing to the high index of refraction, rays which meet the lower facets at an angle greater than $24^\circ 13'$ are internally totally reflected, and emerge above the girdle, owing to the very strong dispersion, yielding prismatic color. The high index of refraction and strong dispersion are the two properties which

produce the brilliancy and luster of a well-cut, perfect stone. Diamond is pure carbon, yielding on combustion carbon dioxide and .05 to .20 per cent. of ash. This foreign matter is due to impurities or inclusions, and it is these impurities which cause the various shades of color; the yellow shades predominate, and while often more brilliant are not as valuable as those of a steel-white color; blue, green, or red diamonds are the most valuable of all gems.

Cleavage fragments and dark brown specimens are termed bort and are used in glass cutters, or reduced to dust for polishing. Another most important use is in core drilling, a most convenient and economical method of prospecting mining properties. Carbonado, a black variety, from the province of Bahia, Brazil, occurring in rounded masses, lacks the perfect cleavage of the transparent stones. It is slightly porous and therefore of a lower specific gravity, yet harder than the well-crystallized material, and is said to yield better results in drilling than the diamond fragments.

The commercial unit of weight used in estimating the value of diamonds, as well as other precious stones, is the carat. Like all of the old units of measure the carat of merchants of different countries varied from 188.5 to 254.6 milligrams; the weight commonly used was from 205 to 207 milligrams. The metric carat of 200 milligrams is now the legal carat in all countries using the metric system.

All diamonds of the ancients and of Europe until 1727, when diamonds were discovered in Brazil, were from the East, where they were obtained from alluvial washings and in conglomerates, especially at Purteal and Goleonda, India. The noted diamonds of these fields are the Koh-i-noor, of 186 carats and now recut to 106; the Pitt or Regent, a yellow stone of 137.5 carats, now in the Galerie d'Apollon in the Louvre, Paris (this stone was appraised in 1791 at 12 million francs); the Orloff, of 194 carats; the Blue Hope, of 44.5; and probably the Great Mogul, of 279 carats.

In 1727 diamonds were discovered by the miners in the gold washings of Minas Geraes, Brazil; since then these workings have yielded continuously large quantities of good stones. Here also the crystals are obtained in river washings and prairie deposits and are associated with a peculiar quartz schist or flexible sandstone, termed itacolumite. The most famous diamond of the Brazilian field is the "Star of the South," weighing 247.5 carats uncut and 125 when cut.

The Vaal River locality of South Africa was discovered in 1867,

where the first diamond was taken from the sands of the river by some Boer children; attracted by its brightness, they carried it home to add to their playthings. It weighed in the rough 21.25 carats and sold for 500 pounds. In 1869 the "Star of South Africa" was found by a black shepherd on the Orange River; this was a magnificent white stone of 83.5 carats and cut to 46.5. After passing through several hands it was sold to the Earl of Dudley for 125,000 dollars. In 1870 diamonds were found at Kimberley, for the first time unmistakably in their primary position, contained in a peculiar peridotite in the form of pipes and plugs, filling the craters of ancient volcanoes. By decomposition this rock forms the famous "blue earth" from which the South African diamonds are obtained, and in which they are associated with garnets, magnetite, enstatite, augite, chromite, olivine, corundum, etc. Other similar pipes were subsequently discovered, all of which have been consolidated in the De Beers Company limited, which has produced nearly all the world's supply of diamonds for the last twenty-five years. The largest diamond ever found was the Cullinan, weighing $3253\frac{3}{4}$ carats, taken on June 6th, 1905, from the walls of the Premier mine near Pretoria, South Africa. Before this discovery, the "Excelsior Jubilee," weighing $971\frac{3}{4}$ carats, discovered in the Jagersfontein mine in the Orange River colony, was the largest. Both of these diamonds, though they were of beautiful color, owing to internal flaws were cleft and cut into various stones. The Cullinan was originally purchased by the Transvaal Assembly for 1,000,000 dollars and presented to Edward VII. It is now a part of the Royal Regalia deposited in the Tower of London.

In the United States diamonds have been found in North Carolina, Georgia, Virginia, Colorado, California, and Wisconsin, all of which were loose in gravel or sand. In 1906 diamonds were discovered in Pike County, Arkansas, in a peridotite resembling, in many respects, the deposits of South Africa. Several companies have been formed and some 1200 diamonds have resulted, yielding, when cut, gems of good color. They are small, very few weighing over one carat. The largest yet found was a stone of 6.5 carats.

The origin of diamonds has not as yet been satisfactorily explained. They have been crystallized, probably from carbon dissolved in a fused magma and under high pressure. The source of this dissolved carbon is in doubt; it may have been brought up from depths with the igneous rock or acquired from shales contain-

ing organic matter, through which the magma, while still in a fused condition, was forced. In most cases this magma has been basic, containing large quantities of magnesium silicates. After solidification they are of the nature of peridotites.

Artificial diamonds were produced by Moissan, by dissolving carbon in fused iron; upon cooling the fusion quickly in melted lead, the outer portions solidify first and the resulting contraction subjects the still liquid interior to enormous pressure. Under these conditions the excess carbon was separated as small diamonds. If the fusion was cooled slowly and without pressure, the more stable crystalline form of carbon, graphite, was formed. The diamonds contained in meteors, as the Cañon Diablo specimens, must be of this nature. Diamonds were also produced by J. Friedlander, who dissolved graphite in fused olivine; from these experiments it was found that fused magnesium and calcium silicates dissolved carbon and favored its separation on cooling in the form of diamond, a condition very similar to that of the natural deposits.

GRAPHITE

Graphite. — Carbon, Black Lead, Plumbago; C; Hexagonal; Type, Dihexagonal Alternating; $c = 1.3859$; $0001 \wedge 10\bar{1}1 = 58^\circ$, $r \wedge r' = 94^\circ 31'$; Common forms, c (0001), r ($10\bar{1}1$); Cleavage basal, perfect; Laminae, pliable; H. = 1-2; G. = 2-2.3; Color, black to steel-gray; Streak, gray to black; Luster, metallic to dull and earthy; Opaque, feels greasy and marks paper.

B.B. — Infusible, deflagrates on coal when mixed with nitre and heated to a high temperature. Insoluble in acids.

General description. — Occurs when crystalline in thin tabular crystals flattened parallel to the base, often in foliated masses, radiated scaly, compact or earthy. Many specimens are impure from oxides of iron, clay, or mixture with sand.

Cliftonite is an isometric form, harder than graphite, contained in a meteoric iron from Australia and also from Cooke County, Tennessee; these crystals have been regarded as pseudomorphs after diamond.

Graphite is very common in crystalline schists, as in the Adirondacks and at Ticonderoga, New York, and High Bridge, New Jersey, where it has been formed from the organic matter, contained in the original sedimentary deposits, by the metamorphic action of heat

and pressure. It occurs in disseminated scales in crystalline limestones, as the Laurentians of Canada. The graphite of Colfax County, New Mexico, was formed by contact of intruded igneous rock with coal beds. Graphite occurs associated with diamond in the Cañon Diablo meteor, and with native iron in the basalt of Ovikak, Greenland. A pegmatite of Maine contains 9 per cent. of graphite, which has separated from the magma after the feldspars and is contained as inclusions in the quartz. Graphite contained in fissures and veins at Ticonderoga suggests a pneumatolytic origin.

Commercially most of the graphite mining in the United States is carried on at Ticonderoga; this is the crystalline form of graphite and is used in the manufacture of crucibles, for the melting of alloys and the refining of metals. The Ceylon product is considered better, being more fibrous, requiring less binder; at the present time these mines supply most of the world's product. Graphite has been used in pencils for several hundred years; an amorphous product from Sonora, Mexico, is considered to be the best for this purpose. A finely ground graphite is mixed with oil as a lubricant. It is also used for electrodes in the electrochemical industries, and the impure forms are used as a paint to protect iron-work from rusting.

Artificial. — Fused metals dissolve carbon, iron as much as four per cent., a large portion of which separates as graphite on cooling. Thus cast iron contains carbon as graphite, which has been formed under the same conditions as that contained in meteoric iron. It is common in slags of blast furnaces. Graphite is produced at Niagara Falls electrolytically, by the Acheson process, competing commercially with the natural product.

SULPHUR

Sulphur. — S; Orthorhombic; Type, Digonal Holoaxial; \bar{a} : \bar{b} : \bar{c} = 0.8131 : 1 : 1.9034; $100 \wedge 110 = 39^\circ 6'$, $001 \wedge 101 = 66^\circ 52'$, $001 \wedge 011 = 62^\circ 17'$, $111 \wedge 001 = 71^\circ 39'$; Common forms, **c** (001), **P**(111), **p** (111), **e** (101), **s** (113), **n** (011); Twinning plane, 101; Cleavage, **c** and **m** perfect, **p** imperfect; Brittle; Fracture, conchoidal; H. = 1.5-2.5; G. = 2.05-2.09; Color, sulphur yellow and various shades of yellow; Streak, white; Luster, resinous; Transparent to translucent; $\alpha = 1.950$, $\beta = 2.038$, $\gamma = 2.240$; $\gamma - \alpha = .290$; Optically (+); Plane of the optic axes = 010; $Bx_a = \bar{c}$, $2V = 69.5^\circ$.

B.B. — Fuses easily at 114.5° and burns with a blue flame, forming sulphur dioxide. When pure, volatilizes entirely. Insoluble in acids. Dissolves in carbon disulphide.

General description. — Crystals are pyramidal in habit, terminated by the base, the two domes *e* and *n*, and the pyramids *s*; many other forms have been described, all of which are rare. Some



FIG. 393. — Sulphur Crystals from Girgenti, Sicily.

crystals are sphenoidal in habit, indicating the holoaxial symmetry. The best examples of sulphur crystals are found at Girgenti, Sicily, where they occur associated with celestite and other sulphates. More often the crystals are small or the sulphur is incrustated, massive, or powdery, mixed with clay, marl, or other impurities. Sulphur is a non-conductor of heat, and a peculiar crackling noise may be noted when a crystal is held to the ear, in the hand, due to the uneven heating; in this way crystals often fall to pieces.

Sulphur is deposited around volcanoes and solfataras, where it is condensed from vapors or reduced by the interaction of SO_2 and H_2S , or again by the oxidation of H_2S . Many hot springs contain H_2S in solution which on oxidation deposits sulphur. In sedimentary deposits sulphur is formed in the reduction of sulphates, and is often associated therefore with celestite and gypsum. It has also been observed in the cracks of galena, as at the Wheatley mine, Pennsylvania.

Deposits of sulphur in the United States are found in the Yellowstone Park, in a rhyolitic tuff; at Black Rock, Utah; at Cody,

Wyoming. But by far the most important deposit, is at Bayou Choupique, Lake Charles, Louisiana, where a bed of almost pure sulphur 100 feet thick, lies at a depth of 440 feet below the surface. This deposit furnishes nearly all the 350,000 tons annually consumed in the United States, most of which was formerly imported from Sicily.

Large quantities of sulphur are used in the wood pulp industry; in the manufacture of matches; in blasting powder; in vulcanizing rubber, and in bleaching through the chemical action of SO_2 .

Artificial crystals may be formed by evaporating a saturated solution of sulphur in carbon disulphide. There are many allotropic forms of sulphur; α -sulphur is stable at ordinary temperatures, while monoclinic, β -sulphur, forms when melted sulphur is allowed to cool until a crust forms, which is broken and the still liquid interior is poured off, when crystals of this monoclinic form will cover the walls. On standing they become opaque from the formation of small crystals of the more stable orthorhombic form.

PLATINUM

Platinum. — Pt; Isometric; Type, Ditesseral Central; Common forms, c (100), o (111), d (110); Malleable; Sectile and ductile; H. = 4-4.5; G. = 14-19, when pure, 21.42; Color and streak, steel-gray; Luster, metallic; Opaque.

B.B. — Infusible, fusing point 1755° . Soluble in hot aqua regia. For other tests see page 582.

General description. — Crystals are not common, but the cube, octahedron, and rhombic dodecahedron occur. Usually it occurs as fine grains or in irregular rolled masses. Native platinum is always alloyed with other metals of the platinum group, as osmium, iridium, palladium, rhodium, and ruthenium, all of which occur only in the native metallic state, with the exception of platinum, which occurs in sperrylite (PtAs_2) as an arsenide, and ruthenium in laurite (RuS_2) as a sulphide. In addition platinum often contains iron, nickel, and gold, to which its variable specific gravity and hardness are due.

Deposits of platinum are associated with basic rocks, as serpentine and peridotite. Its most constant companion is chromite. Platinum was first discovered in the gold washings of the Pinto River, Colombia, South America, about the year 1720, and in the

alluvial deposits of the Ural Mountains, Russia, in 1822. Here nuggets weighing as much as 18 kilos were found. The largest, weighing 18.57 kilos, is in the Demidoff collection of minerals at St. Petersburg. The larger part of the world's supply of the present day, about 15,000 pounds annually, is derived from the Russian deposits. A peculiar black sand left with the gold in the washings of the Pacific slope, particularly in British Columbia and the states of Oregon and Washington, contains small amounts of platinum; from this source a few ounces are obtained annually. Platinum has been reported as contained in a serpentine of the Urals; in a pegmatite of Copper Mountain, British Columbia; in a decomposed schist of Broken Hill, Australia; in limonite nodules in Mexico; in an altered limestone of Sumatra. In addition it is connected with certain sulphides, as the pyrrhotite of Sudbury, Canada; covellite in Wyoming; and chalcopyrite of the Key West mine near Bunkerville, Nevada, where it is associated with nickel, as at the Sudbury locality. Possibly in these associations platinum may be in the form of arsenide, as sperrylite has been reported from both Sudbury and the British Columbia localities, but has not as yet been reported from Nevada.

Owing to the high fusing point and its insolubility in single acids, platinum crucibles are used in chemical analyses. It is also used in thermoelectric couples for the measurement of high temperatures; as a catalyzer to oxidize SO_2 to SO_3 in sulphuric acid works. Having the same coefficient of expansion as glass, it is used to carry the electric current through the glass walls of physical apparatus. There are many other minor uses; and since the supply cannot keep pace with the demand, the price is constantly increasing, until at the present time platinum is more than double the value of gold.

COPPER

Copper. — Native Copper, Cu; Isometric; Type, Ditesseral Central; Common forms, a (001), o (111), d (101), h (410); Twinning plane, 111; Malleable, ductile; Fracture, hackly; H. = 2.5-3; G. = 8.8-8.9; Color, copper red; Streak, shining; Metallic; Opaque.

B.B. — Easily fusible (1084°). In the blue cone of the O. F. yields a green flame. On coal becomes black after fusion from the formation of black oxide. Dissolves in HNO_3 or HCl , yielding a solution which becomes intensely blue on the addition of an excess of ammonia.

General description. — Copper crystallizes in cubes, octahedrons, and tetrahexahedrons; other forms are rare. Twins after the spinel law are not uncommon. It occurs more often in distorted forms, or in arborescent, reticular, dendritic, filiform, and irregular masses. Pseudomorphs after other copper minerals, as cuprite, malachite,



FIG. 394. — Native Copper and Quartz from Lake Superior.

and azurite, are often formed by double decomposition and reduction. Native copper is usually coated with a coat of oxides or carbonates; many masses of cuprite still contain as a central nucleus some of the metallic copper from which they were formed.

Native copper occurs as a secondary product, either formed by precipitation from solution, or by the chemical action of reducing agents upon minerals containing copper. Percolating ground waters dissolve copper and especially under heat and pressure; even distilled water will dissolve copper under these conditions, leaching out the original copper content of the igneous rocks and transporting it to points, as veins and cavities, where it may be precipitated by contact or by intermingling with other solutions containing a reducing agent, as ferrous iron, which is capable, either as oxide, sulphate, silicate, or carbonate, of precipitating copper from its solutions.

The large deposits of the Lake Superior region have probably been formed in this way. Here metallic copper, generally in small particles, is contained in the amygdaloid cavities of a conglomerate. One mass of 400 tons was found in the Minnesota mine. Originally the copper must have been contained in the adjacent igneous

rocks, but is now concentrated by solution and precipitation in the conglomerate.

Native copper is also found in the Copper Queen mine, Arizona; in sheets at Enid, Oklahoma, and associated with fossil bones in Peru, evidently reduced by the organic matter of the bone. Small amounts of copper are present, usually as a secondary product, in nearly every copper region and mine; but only in the Lake Superior region does it constitute nearly all the copper content of the ore.

The United States produced, in 1911, 550,645 tons, nearly one half of the world's product; of this Lake Superior region contributed 110,700 tons; Montana, 141,250 tons, and Arizona, 110,500 tons.

SILVER

Silver. — Native Silver, Ag; Isometric; Type, Ditesseral Central; Common forms, **a** (100), **o** (111), **d** (101); Twinning plane, 111; Malleable and ductile; Fracture, hackly; *H.* = 2.5–3; *G.* = 10.1–11.1; Color and streak, silver-white; Luster, metallic; Opaque.

B.B. — Fuses easily (955°), and in O. F. on coal yields a brown coat of silver oxide. Soluble in nitric acid. Other tests for silver are given on page 578.

General description. — Crystals are usually elongated or distorted octahedrons. All seven forms of the type occur on silver crystals, but others than the octahedron and cube are comparatively rare. In occurrence it is more often, in dendritic or arborescent growths, due to twinning and parallel positions; sheets, wire, and disseminated scales are also common.

On exposure the bright surfaces become brown to black, from the formation of sulphides. Owing to its solubility and the easily formed sulphides, silver is not found in placer deposits, but it is associated with gold and copper in vein deposits, where most of the native silver is of secondary origin, being reduced from sulphides, chlorides, and other compounds.

Masses of native silver weighing from 500 to 1000 pounds have been taken from the deposits of Cobalt, Ontario, where it is associated with ores of cobalt and nickel. Masses weighing as much as 800 pounds have been found at Huantaya, southern Peru, while beautiful specimens of crystalline and wire silver are obtained in the mines of Batopilas, Mexico; and Kongsberg, Norway. In the

United States alloys of silver and copper are found in the copper mines of the Lake Superior region, the Poor Man's Lode, Idaho, and many localities through the West. Mexico is the largest producer of silver, with 72,000,000¹ ounces, while the United States produced 57,796,117 ounces, and Canada, 31,500,000 ounces, in 1911.

GOLD

Gold. — Native gold, Au; Isometric; Type, Ditesseral Central; Common forms, o (111), d (110); Malleable and ductile; Fracture, hackly; H. = 2.5–3; G. = 15.8–19.3; Color and streak, gold-yellow; Luster, metallic; Opaque.

B.B. — Fuses easily (1065°). Insoluble in acids except aqua regia, also in nascent chlorine, and in potassium cyanide in presence of oxygen. For other tests see page 582.

General description. — When crystalline, usually in octahedrons elongated parallel to one axis or flattened parallel to a face. Also in arborescent and reticular shapes, or sheets, disseminated scales, and rolled water-worn masses, known as nuggets.

The purest native gold is said to be that of Mount Morgan, Queensland, 99.7 per cent. gold. Most gold contains silver; electrum from Hungary is a pale yellow natural alloy containing 30 per cent. silver.

Gold may also contain copper, iron, lead, bismuth, platinum, or mercury, most of which reduce its specific gravity and modify its color.

Gold is nearly world-wide in occurrence, though in very small quantities except where it has been concentrated by secondary causes. Most of the world's gold, until recent years, was recovered from river sand and alluvial deposits, where, owing to its high specific gravity and insolubility, it has remained behind unchanged for centuries. Such gold is recovered by the simplest of all mining, placer, which consists of washing the lighter sands away, in sluices or pans. All placers of the world are worked by modifica-

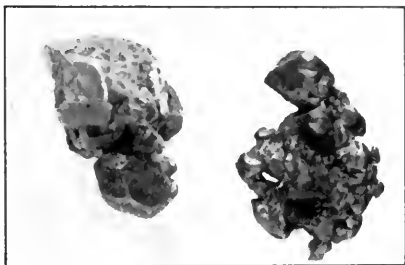

FIG. 395. — Crystals of Gold. Australia.

tions of this simple method, which reduces the cost of handling the enormous quantities of material made necessary. By the hydraulic method in California the cost has been so reduced that a cubic yard of earth can be handled at a cost of two cents.

The largest nuggets have been taken from the gravels of Australia, one weighing 190 pounds, another 180 pounds. Gold occurs in quartz veins, especially the veins of schists, porphyry, and those rocks high in silica. Less often do the veins of basic rocks contain gold, though it may be found in some limestones and slates. It is probably more soluble in magmas high in silica.

Gold as a primary mineral has been reported in granite from Mexico; in pitchstone from Chili; and small amounts of gold are shown by assay to be contained in granites, syenite, basalt, and diabases of California.

Gold is soluble in sodium or potassium silicates, ferrous sulphates and chloride, and the alkali sulphides. The small amounts of gold contained in the country rocks are dissolved by these natural solvents and transported in solution by the percolating waters to veins or cavities where, through a changed physical condition, as a reduction of temperature and pressure, or by contact with a precipitant, they are deposited. As evidence of such concentration, gold is being deposited with the siliceous sinter at the Steamboat Springs of Nevada and at the hot springs of New Zealand, and its presence in sea water has been repeatedly verified.

Gold in solution is very unstable and is easily precipitated by such agents as organic matter, ferrous salts, metallic sulphides, especially those of iron, copper, zinc, arsenic, and antimony; with the ores of these metals gold is often associated.

Pyrite is a constant companion of gold in quartz veins, inclosing it within the body of the crystals as inclusions; the pyrite on oxidation is mostly carried away, leaving the gold behind, contained in a porous, rusty quartz, always so pleasing in appearance to the old prospector.

The largest producing gold mines of the world are on the Rand in South Africa; at Victoria, Australia; and in the United States. The United States produced, in 1911, \$96,233,428 of pure gold, the mint value of which is \$20.6718 per ounce troy or \$0.6646 per gram. To this production twenty states contributed, of which Colorado, Alaska, California, Nevada, and South Dakota, in order, were the largest producers.

Gold is the basis of the world's coinage; that of the United

States is 9 parts gold to 1 of copper, or 900 fine. The proportion in jewelry is designated by the carat, 24 carat being pure gold. In England the usual standard is 22 carat, or 916.67 fine.

MERCURY

Mercury. — Quicksilver, Hg; Isometric; Type, Ditesseral Central; Crystals, octahedrons; Liquid at ordinary temperatures; Solid at -39° with cubic cleavage; G. = 13.6; Color, tin-white; Brilliant metallic luster; Opaque.

B.B. — Volatilizes entirely when pure, yielding a gray coat on coal. See tests on page 579.

General description. — Native mercury is not of common occurrence. It is found as small metallic liquid globules in the gangue associated with cinnabar, from which it has probably been reduced by organic agents. It also occurs in shales, slate, and marls, as at Idria, Austria, one of the important European localities, where it occurs in a clay slate. The deposits of California and Texas where native mercury is found are also associated with sedimentary rocks, which yield hydrocarbon gases. Hot springs, as the Steamboat Springs of Nevada, bring mercury to the surface.

The mercury of commerce is obtained from the sulphide, cinnabar. In the United States, California for a long time was the only producing state, but since the discovery of the mercury deposits at Terlingua, Brewster County, Texas has also been a producer. About twenty-one thousand flasks, of seventy-five pounds each, were produced in the United States in 1911, of which California produced seventeen thousand.

The greatest demand for mercury is in the amalgamation of silver and gold ores. It is also used in the production of vermilion paint, and in smaller quantities in the sciences and in the construction of electrical apparatus.

The metals iron, lead, bismuth, arsenic, and antimony are also found in nature in a free state, but only locally and in very restricted quantities. Iron occurs in meteors and as a primary accessory component in some basalts, as at Antrim, Ireland, in the trap of New Jersey, and in the dolerites of Mount Washington, New Hampshire. The most noted locality, however, is at Disco Island, West Greenland, where large masses, many tons in weight, have weathered out of the basalt; these masses were originally supposed to be meteoric.

CHAPTER V

SULPHIDES, ARSENIDES, ANTIMONIDES

REALGAR

Realgar. — Sulphide of arsenic, As_2S_2 ; As = 70.1; S = 29.9; Monoclinic; Type, Digonal Equatorial; $\hat{a} : \hat{b} : \hat{c} = 1.4403 : 1 : .9729$; $\beta = 66^\circ 5' = 001 \wedge 100$; $100 \wedge 110 = 52^\circ 47'$, $001 \wedge 101 = 40^\circ 22'$, $110 \wedge \bar{1}\bar{1}0 = 105^\circ 34'$, $001 \wedge 011 = 41^\circ 39'$; Common forms, **a** (100), **b** (010), **c** (001), **m** (110), **r** (012); Cleavage, **b** perfect, **c**, **a**, and **m** less so; Sectile; Fracture, conchoidal; H. = 1.5–2; G. = 3.55; Color, a dark orange-red, streak somewhat lighter in color; Luster, resinous; Transparent to translucent; Optically (–); Plane of the optic axes, **b** (010); $\text{Bx}_a \wedge \hat{c} = +11^\circ$; $2V = 92^\circ 58'$.

B.B.— On coal in O. F. burns, yielding an arsenic odor and when pure leaves no residue. In the closed tube yields a cherry-red sublimate of arsenic sulphide, in the open tube yields a white sublimate of As_2O_3 and an SO_2 odor.

General description. — Crystals prismatic, usually combinations of (001), (110), (010) with the prism zone striated lengthwise; also occurs as compact masses, granular, or in crusts. Usually coated with a yellow film of orpiment into which it changes on exposure. Realgar is associated with antimony, arsenic, and silver ores. It occurs as a sublimation product in the lavas of Vesuvius, and at the present time it is being deposited associated with orpiment from the water of the hot springs of Norris Geysir Basin, Yellowstone Park. In the United States it is mined at Monte Cristo, Washington.

Uses. — Mixed with lime, realgar is used in tanning, to remove the hair from the hides; it furnishes the white lights in pyrotechnics. It is also used as a pigment, but the commercial, or ruby, arsenic is an artificial product. When realgar is dissolved in sodium bicarbonate at 150° under pressure, upon cooling the solution, it separates as crystals.

ORPIMENT

Orpiment. — Arsenic trisulphide, As_2S_3 ; $As = 61, S = 39$; Monoclinic; Type, Digonal Equatorial; $\hat{a} : \hat{b} : \hat{c} = .5962 : 1 : .665$; $\beta = 89^\circ 19'$; $110_A \bar{1}\bar{1}0 = 62^\circ 11'$, $120_A 120 = 96^\circ 23'$; Common forms, **m** (110), **u** (120), **o** (101); Twinning plane, 100; Cleavage, **b** perfect, laminae flexible, inelastic; Sectile; $H. = 1.5-2$; $G. = 3.4-4.5$; Color, lemon-yellow; Streak, pale yellow; Luster, resinous; cleavage surfaces pearly; Transparent to translucent; Optically (-); Axial plane, 001.

B.B. — Fuses and volatilizes entirely when pure, yielding an arsenic odor.

General description. — Crystals are rare, but small crystals are found in the clays at Tajowa, Hungary. It occurs usually in foliated or columnar masses with rounded surfaces. It is associated with and may be formed as an efflorescence on realgar.

STIBNITE

Stibnite. — Antimony glance, Sb_2S_3 ; Antimony trisulphide; $Sb = 71.4, S = 28.6$; Orthorhombic; Type, Didigonal Equatorial; $\hat{a} : \hat{b} : \hat{c} = .9926 : 1 : 1.0179$; $100_A 110 = 44^\circ 47'$, $001_A 101 = 45^\circ 43'$, $001_A 011 = 45^\circ 30'$, $111_A 110 = 34^\circ 41'$; Common forms, **m** (110), **p** (111), **b** (010); Cleavage, **b** perfect, **a** and **m** imperfect; Slightly sectile and pliable; Fracture, conchoidal; $H. = 2$; $G. = 4.52-4.62$; Color, steel-gray, tarnishing to black; Streak, lead-gray, marks paper; Luster, metallic, splendid on fresh surfaces.

B.B. — Fuses in O. F. at once (630°) and on coal yields a white coat of Sb_2O_3 , also an odor of sulphur dioxide. When pure, volatilizes entirely, in R. F., yielding a yellowish green antimony flame. Soluble in HCl, but in HNO_3 forms a white insoluble Sb_2O_5 .

General description. — Crystals are long prismatic or acicular with striations and furrows parallel to the \hat{c} axis, usually terminated with the unit pyramid. Numerous forms have been described, especially on crystals from Ichinokawa, Island of Shikoku, Japan, where brilliant crystals nearly two feet in length have been found; in some cases these are peculiarly twisted around the vertical axis. Often in radiated groups and aggregates of acicular crystals, as at Felsöbanya, Hungary, penetrating the tabular crystals of barite with which they are associated. Massive and granular

varieties of stibnite often appear much harder than 2, from the impurities. Crystals of stibnite are at times coated with white crust formed by oxidation, and at times the entire crystal has undergone



FIG. 396. — Stibnite from Lyo Island, Japan.

oxidation, forming pseudomorphs of cervantite (Sb_2O_4) after stibnite, as at Charcas, Mexico.

In the United States stibnite occurs at Lovelocks and Humboldt regions, Nevada; in Iron County, Utah; and in Buck County, Idaho. Very little is mined, as most of the American antimony is obtained in the smelting of lead ores, which contain antimony in small quantities.

The metal is used principally in the alloys, type, babbett, and britannia metal. The trisulphide is used to produce the "Bengal Fire," the trioxide in the glaze of enameled ironware and in coloring glass and porcelain yellow. Many of its salts are used in medicine.

BISMUTHINITE

Bismuthinite. — Bi_2S_3 . The trisulphide of bismuth is a rare mineral, occurring in striated, irregularly terminated prisms. It is found in small quantities in Rowan County, North Carolina, associated with gold, and in the gold ores of Goldfield, Nevada. Lead ores contain bismuth and most of the commercial metal is produced in the electrolytic refining of lead.

MOLYBDENITE

Molybdenite. — MoS_2 ; Sulphide of molybdenum; Mo = 60, S = 40; Hexagonal; Type, Dihexagonal Equatorial; $c = 1.098$;

0001 \wedge 10 $\bar{1}0$ = 65° 35'; Crystal forms, **c** (0001), **m** (10 $\bar{1}0$); Cleavage, **c** perfect, laminae flexible but inelastic; H. = 1-1.5; G. = 4.7-4.8; Color, lead-gray to bluish gray to bluish black, marks paper, and feels greasy; Streak, bluish gray; Luster, metallic; Opaque.

B.B. — Infusible in the forceps, but yields a green flame. The powdered mineral on coal in O. F. yields a white coat. In the open tube yields SO₂. Decomposed with HNO₂, moistened with H₂SO₄, and evaporated in a porcelain crucible, yields a blue residue on cooling.

General description. — Crystals are tabular, parallel to the base, and six-sided, with the prism faces irregularly striated and furrowed horizontally. Several prisms have been described, but good faces are rare. Usually much like graphite in appearance. In flat scales disseminated through granite and pegmatites, as at Cooper, Maine. It occurs also in gneiss, schist, gabbro, granular limestones, and in quartz veins, as at Chelan County, Washington, and Beaverhead County, Montana. Crystals two to three inches across have been found in Okanogan County, Washington, and at Aldfield, Pontiac County, Quebec.

While molybdenite occurs in many localities in the United States, they are all small deposits, two of which are at present mined, that at Cooper, Maine, and in Washington, even though molybdenite is the principal ore of the metal and is quoted as being valued at \$1.50 per pound.

The metal is used in making tool steel; as ammonium molybdate in the determination and separation of phosphoric acid in iron ores; in the staining of leather, and as sodium molybdate in the coloring of pottery blue. Artificial crystals of molybdenite have been formed by fusing the oxide with sulphur and potassium carbonate.

ARGENTITE

Argentite. — Silver glance; Ag₂S; Sulphide of silver; Ag = 87.1; S = 12.9; Isometric; Type, Ditesseral Central; Common forms, **o** (111), **a** (001), **d** (110); Twinning plane, 111, interpenetrating; Cleavage, **a** and **d** in traces; Sectile and malleable; H. = 2-2.5; G. = 7.2-7.35; Color, dark lead-gray; Streak, gray, shining; Luster, metallic; Opaque.

B.B. — Fuses with intumescence in O. F. on coal, yielding a globule of silver and a sulphur dioxide odor.

General description. — Crystals are octahedrons, rhombic dodecahedrons, cubes, or combinations of these forms; all forms of the type have been observed on argentite, but the other four forms are rare. Fresh surfaces are bright and shiny, but like all silver minerals become dark on exposure. Its occurrence is more often



FIG. 397. — Argentite from Freiberg, Saxony.

dendritic, granular, or disseminated. At the Comstock Lode, Nevada, it alone constitutes a workable silver ore; also at Port Arthur, Lake Superior. It occurs in small amounts in most silver mines, and in the cobalt region, Canada, in considerable quantities.

It is usually associated with stephanite, galena, pyrite, cobalt, and nickel ores, gold, and silver, the latter being a secondary product reduced from the sulphide.

Argentite and galena are isomorphous, and the latter, especially the fine granular varieties, contains small amounts of silver, and the smelting of galena yields each year a considerable amount of the world's production of silver.

Silver in solution, either as the sulphate, carbonate, or nitrate, is precipitated by the natural sulphides as pyrite, chalcopyrite, bornite, or galena, a reaction which without doubt plays an important part in the secondary enrichment of silver ores.

GALENA

Galenite. — Galena; Lead glance; PbS , lead sulphide; $Pb = 86.6$, $S = 13.4$; Isometric; Type, Ditesseral Central; Common forms, a (100), o (111), d (110); Twinning plane, 111, both contact and interpenetrating; Cleavage cubic, perfect; Brittle; Fracture, subconchoidal; $H. = 2.5-2.75$; $G. = 7.4-7.6$; Color and streak, lead-gray; Opaque.

B.B. — Fuses easily on coal in the O. F., yielding SO_2 fumes and a yellow oxide of lead coat, which is often quite white with lead carbonate or sulphate. In R. F., especially when mixed with soda, is reduced to malleable lead. The soda fusion, when placed on a silver surface and moistened, leaves a black stain (S). Dissolves in nitric acid, forming insoluble white lead sulphate (PbSO_4).

General description. — Crystals are usually cubic or combination of the cube and the octahedron, less often the rhombic dodecahedron; the simple octahedral habit is rare. Other forms occur



FIG. 398. — Galena Crystals. Bavaria.

which at times give the crystals a rounded appearance; cube faces are often vicinal. Twins after the spinel law are flattened, as is usual with twins of this class. Cleavage is cubical with brilliant surfaces, and in some cases striated from polysynthetic twinning; in rare exceptions, as at Lancaster, Pennsylvania, and Nordmarken, Sweden, the cleavage is octahedral; such specimens have always been found to contain bismuth. Massive, granular, and disseminated varieties are common, but fibrous and plumose specimens are rare. Galena contains as impurities zinc, copper, cadmium, bismuth, arsenic, and antimony, possibly as sulphides; also gold and silver; often the silver value is greater than that of lead, when it constitutes a true silver ore.

Galena occurs both as a primary and secondary mineral, but by far the most important commercially are the secondary vein deposits or those filling cavities in limestone formations, where it is associated with sphalerite and chalcopyrite. The gangue of such

veins is usually calcite, siderite, barite, or fluorite. Such deposits have been formed by the precipitation of lead, carried in solution as the carbonate, sulphate, or even the sulphide (as galena is deposited by some thermal springs), by water, percolating down from the superficial areas, which tends to dissolve the oxidized ores at the surface and again deposit them as sulphides at lower levels; deposits formed in this way are apt to become poor at depths. Galena may be deposited by ascending solutions, in which case the supply is brought nearer the surface from depths; also lead sulphide is volatile without decomposition when heated in an atmosphere of many gases, and on cooling recrystallizes as cubes; galena of this nature has been observed in the lavas of Vesuvius.

Galena is very widely distributed; of the 24 states commercially producing lead ore in 1909, Missouri, Idaho, Utah, and Colorado produced more than three quarters of the 350 thousand tons of that year. The deposits of Missouri, Southern Illinois, Wisconsin, and the Mississippi valley generally are found in limestone and dolomite. Those of Idaho and Colorado are associated with igneous rocks as well as dolomite; others, associated in veins with gold, silver, and copper ores, are of a complex nature, and the usual gangue mineral is quartz.

Artificial galena crystals have been produced by the volatilization of precipitated sulphide, and by the precipitation of a solution of lead nitrate containing free nitric acid. Octahedral crystals are formed when one part of lead sulphide is fused with six parts each of potash and sulphur.

CHALCOCITE

Chalcocite. — Copper glance; Cu_2S ; Cuprous sulphide; $\text{Cu} = 79.8$, $\text{S} = 20.2$; Orthorhombic; Type, Didigonal Equatorial; $\bar{a} : \bar{b} : \bar{c} = .5822 : 1 : .9701$; $100 \wedge 110 = 30^\circ 12'$, $001 \wedge 101 = 59^\circ 2'$, $001 \wedge 011 = 44^\circ 8'$; Common forms, **a** (100), **b** (010), **c** (001), **m** (110); Twinning plane, 110 and 032; Cleavage, **m** distinct; Brittle, fracture conchoidal; $H. = 2.5-3$; $G. = 5.5-5.8$; Color and streak, dark lead-gray, tarnishes to blue on exposure; Luster, metallic; Opaque.

B.B. — On coal fuses easily and boils with spirting. In O. F. yields SO_2 fumes and odor. Powdered and roasted without fusing, then heated in R. F. yields malleable copper, also shows copper with the fluxes.

General description. — Crystals are tabular parallel to the base, combinations of the base, prism, and pinacoid with a pyramid and dome; as the prism angle is $119^{\circ} 35'$, these combinations are pseudo-hexagonal in symmetry. This is even more striking when twinned; such crystals are found at Bristol, Connecticut, and in Cornwall, England. The base is often striated parallel to the edge *c/d*. Massive, granular, or disseminated chalcocite is more common than the crystalline. Specimens are often coated with a black crust of melaconite or of the green and blue carbonates, and less often with the blue sulphide, covellite; all of which are alteration products of chalcocite.

Stromeyerite (CuAg_2S), as it is variable in composition, is probably a mixture of acanthite, Ag_2S , the orthorhombic sulphide of silver, and chalcocite, which in many localities contains silver.

Chalcocite is a mineral of secondary origin associated with other copper ores, with arsenopyrite, tetrahedrite, sphalerite, pyrite, and galena, in veins, joints, lenses, etc., in which the gangue mineral is principally quartz. At Butte, Montana, probably the largest copper camp of the world, the sulphide ore is 50 per cent. chalcocite. It is also an important mineral at Bingham Cañon, Utah, associated with pyrite and chalcopyrite, both of which are enriched with chalcocite. Chalcocite occurs more or less abundantly in all copper deposits, in the zone of secondary enrichment, where it has been precipitated from the descending solutions, by contact with pyrite, sphalerite, galena, or sulphides of arsenic, etc.

Artificial chalcocite may be produced by heating a solution of cuprous sulphide in a sealed tube with a solution of ammonium sulphocyanate.

SPHALERITE

Sphalerite. — Zinc blende; black jack, ZnS , zinc sulphide; $\text{Zn} = 67$, $\text{S} = 33$; Isometric; Type, Ditesseral Polar; Common forms, $\pm o$ (111), d (110), a (100); Twinning plane, 111; Cleavage, dodecahedral, perfect; Brittle, fracture conchoidal; $H. = 3.5-4$; $G. = 3.9-4.1$; Color, shades of yellow, brown to black, rarely red, green, or white; Streak, pale to colorless; Luster, adamantine; Transparent to opaque; $n. = 2.369$; Pyroelectric and polar in the direction of the trigonal axes.

B.B. — Infusible or nearly so; powdered and reduced on coal with soda yields a white zinc oxide coat, which may be more or

less yellow when cold, from the presence of cadmium; this coat moistened with cobalt solution and again heated in the O. F. becomes green; the soda fusion yields a sulphur reaction on silver. Soluble in hot HCl, evolving sulphuretted hydrogen.

General description. — Crystals are usually combinations of the plus and minus tetrahedrons with the cube or the dodecahedron, less often with the trigonal trisoctahedron (311). They are often

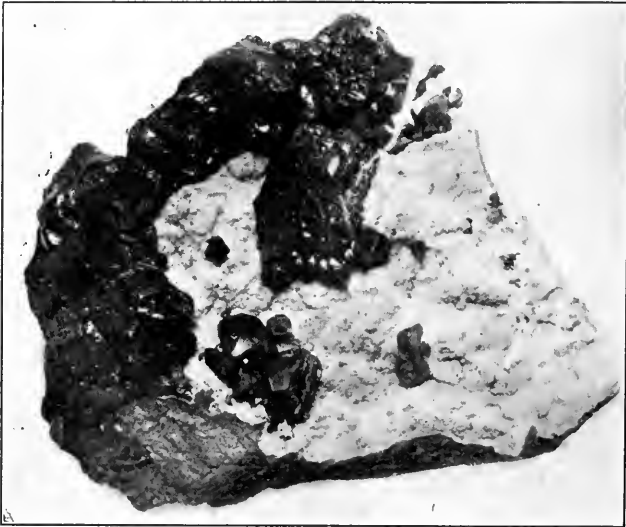

FIG. 399. — Sphalerite and Calcite. Joplin, Missouri.

rounded on the tetrahedral edges and striated parallel to the intersection of the two tetrahedrons; on the cube face these striations are diagonal, showing its hemihedral symmetry.

Twins after the spinel law are common and may be developed polysynthetically. Granular, compact, fibrous, or foliated varieties are common. Pure sphalerite is white and occurs at Franklin, New Jersey, and at Nordmarken, Sweden. It is usually colored with iron or manganese, even though these metals are present only in very small quantities. Cadmium sulphide, being isomorphous with zinc sulphide, is usually present, in some localities as high as 5 per cent. The very dark specimens contain small quantities of indium, gallium, or thallium; gallium was first discovered by Lecoq de Boisbaudran in 1875 in a specimen of blende from Pierrefitte, Pyrenees. Indium was discovered in 1863 by Reich and Richter

in a blende from Freiberg, Saxony. Specimens containing these rare elements are very dark in color, as that from Roxbury, Connecticut. Sphalerite is found under the same conditions and in the same formations as galena, which is its constant companion, with the exception that zinc sulphide is more soluble than lead sulphide and in many cases in the oxidized zones the zinc has been carried away in solution, leaving the galena. The oxidation products of sphalerite are calamine and smithsonite, which are ores of the superficial areas of zinc deposits. In weathering these may be redissolved and carried down by the percolating waters. This is well substantiated by the analyses of the mine waters at Freiberg, where it was estimated that the discharge in the valley carried 479 kilograms of zinc per day, or 175,024 kilograms per year. In undisturbed deposits such solutions of zinc are reprecipitated either by pyrite, marcasite, or organic matter as a sulphide, or by replacement in limestones as a carbonate. When sphalerite is formed, these reactions take place at low temperatures, as wurtzite, the hexagonal zinc sulphide, is the stable form at high temperature. Simple crystals of sphalerite occur in the dolomites of the Binnenthal, and beautiful specimens are obtained at Santander, Spain.

In the United States sphalerite is widely distributed in the limestones of the Mississippi valley, and the regions of contact of limestones with igneous rocks; all deposits of sphalerite mined for the zinc alone are of these characters. Southern Missouri and the Leadville district, Colorado, both blende deposits, produced 175 thousand of the 280 thousand tons of ore mined in 1909. Sphalerite also occurs, but of minor importance, in the metalliferous veins of rocks of all ages.

Zinc is used in innumerable ways; as a metal it is a component of brass, white metal, and german silver. It is used in roofing in galvanizing iron to prevent rusting, and in the zinc boxes as a reducing agent to precipitate gold from the solutions in the cyanide process; as an oxide in paint, and at the present time is to a large extent displacing white lead. Artificial sphalerite is formed when a solution of zinc is heated in a sealed tube with hydrogen sulphide, at higher temperatures. In fusions, as of precipitated zinc sulphide with potassium carbonate and sulphur, or with calcium fluoride and barium sulphate, the hexagonal form of ZnS , wurtzite, is formed. Sphalerite when heated to bright redness is changed to wurtzite.

ALABANDITE

Alabandite. — MnS ; Manganese sulphide; $\text{Mn} = 63.1$, $\text{S} = 36.9$; Isometric; Type, Ditesseral Polar; Common forms, a (100), d (110), $\pm o$ (111); Twinning plane, 111; Cleavage, cubic, perfect; $H. = 3.5-4$; $G. = 3.95-4.04$; Brittle, fracture uneven; Color, iron-black; Streak, green; Luster, dull submetallic.

B.B. — On coal in O. F. yields sulphur dioxide odor; the black oxide remaining reacts for manganese with the fluxes. Soluble in dilute hot HCl , yielding hydrogen sulphide.

General description. — Crystals are combinations of the cube and the rhombic dodecahedron, often repeatedly twinned after the spinel law; more often massive or granular. On exposure weathers to a brown color.

Alabandite is not a common sulphide, and for that reason it is commercially unimportant. In the United States it occurs in the Snake River region, Colorado, where it is associated in veins with argentite, pyrite, galena, and rhodochrosite, also at Tombstone, Arizona, in large but rough twinned cubes.

CINNABAR

Cinnabar. — HgS ; Mercuric Sulphide; $\text{Hg} = 86.2$, $\text{S} = 13.8$; Hexagonal; Type, Trigonal Holoaxial; $c = 1.1453$; $0001 \wedge 10\bar{1}1 = 52^\circ 54'$, $r \vee r' = 87^\circ 23'$; Common forms, c (0001), m ($10\bar{1}0$), r ($10\bar{1}1$); Twinning axis \bar{c} , interpenetrating; Cleavage, m perfect; $H. = 2-2.5$; $G. = 8-8.2$; Slightly sectile, fracture conchoidal; Color, cochineal-red to dark red; Streak, scarlet; Luster, adamantine; Transparent to opaque; $\omega = 2.854$, $\epsilon = 3.201$ $\epsilon - \omega = .447$; Optically (+); Circular polarization.

B.B. — On coal in O. F., when pure, volatilizes entirely, yielding a sulphur dioxide odor and possibly a gray coat. Heated in the closed tube with dry soda yields a sublimate of metallic mercury.

General description. — A very heavy massive reddish brown mineral, at times almost black from organic matter, or earthy and disseminated. Crystals are not common, but occur in rhombohedral habit, in short thick crystals, combinations of the unit prism terminated by a rhombohedron, or by the base, when the habit is tabular. The most general form of the type, the trigonal trapezohedron, is very rare, but several have been described on crystals

from Mount Avala, Servia. Beautiful examples of penetrating rhombohedral twins often repeated are obtained in the province of Kweichow, China. Twinning lamellæ parallel to the base show Airy's spirals as in quartz. The rotary polarization is very strong, some fifteen times that of quartz in sections of the same thickness, while the index of refraction is the highest of minerals.



FIG. 400. — Cinnabar Twins. Hu-Nan, China.

Mercuric sulphide is dimorphous; the red cinnabar forms at a temperature above 45° , while the black isometric, tetrahedral form, meta-cinnabar, forms below 45° C.; the latter form was formerly plentiful at the Reddington mine, Lake County, California.

Cinnabar is associated more abundantly with sedimentary deposits, shales, slates, and organic matter than with quartz schists or porphyries.

The concentrations of cinnabar, forming impregnations in limestones and sandstones, or filling fissures, cracks, and cavities in sedimentary formations near regions of igneous action, owe their origin in most cases to ascending hot alkaline solutions carrying mercury sulphide, as in case of the Steamboat Springs, Nevada; from such solutions the cinnabar is either precipitated by dilution of the solution, by a reduction of pressure, or by contact with organic matter. Pyrite, marcasite, sulphur, barite, gypsum, calcite and quartz are the usual associates.

Cinnabar is the principal ore of mercury; the largest producing deposits are Idria, Austria, and Almaden, Spain. In the United States cinnabar is mined in California at New Idria and New Almaden; in southern Nevada, and at Terlingua, Texas.

The artificial product is used as vermilion paint and is manufactured on a large scale by distilling in iron retorts a mixture of 8 parts sulphur and 42 parts mercury. In the wet way cinnabar may be produced by dissolving a mixture of mercury and sulphur in a caustic potash solution and heating above 45° C., as below this temperature the black phase will form.

COVELLITE

Covellite. — CuS ; Cupric sulphide; $\text{Cu} = 66.4$, $\text{S} = 33.6$; Hexagonal; Type, Trigonal Holoaxial, or Monoclinic; $\bar{c} = 1.1466$, $0001 \wedge 1011 = 52^\circ 56'$; Common forms, c (0001), r ($10\bar{1}1$), m ($10\bar{1}0$), x ($11\bar{2}2$); Cleavage, basal perfect, thin lamellæ, flexible; $H. = 1.5-2$; $G. = 4.59-4.64$; Color, deep indigo-blue; Streak, gray to black; Opaque.

B.B. — On coal in O. F. fuses to a globule and yields SO_2 fumes. Roasted and reduced with soda yields malleable copper.

General description. — Usually in cleavable masses or in disseminated scales, rarely in crystals; less common in occurrence than the cuprous sulphide, chalcocite, of which it is at times an alteration product.

Covellite is a sulphide of secondary origin, probably produced by the interaction of chalcocite and copper sulphide in solution, resulting in covellite and metallic copper. It is associated with other copper minerals, as at Butte, Montana; at the Copper Queen mine, Bisbee, Arizona; and at the Rambler mine, Wyoming. While its percentage of copper is high, owing to its rare occurrence in quantity it is only a minor ore of copper.

GREENOCKITE

Greenockite. — CdS ; Cadmium sulphide; $\text{Cd} = 77.7$, $\text{S}_A = 22.3$; Hexagonal; Type, Dihexagonal Polar; $\bar{c} = 0.8109$; $0001 \wedge 10\bar{1}1 = 43^\circ 7'$; Common forms, c (0010), M ($10\bar{1}0$), p ($10\bar{1}1$); $H. = 3-3.5$; $G. = 4.9-5.0$; Cleavage, prismatic distinct, c less so; Brittle, fracture conchoidal; Color, shades of yellow; Streak, orange-yellow to red; Luster, adamantine to resinous; Transparent to translucent; $\omega = 2.688$; Optically (+).

B.B. — On coal yields a sulphur dioxide odor and a reddish brown coat of cadmium oxide. Reduced with soda yields malleable buttons of cadmium. Soluble in hot HCl , yielding hydrogen sulphide.

General description. — Crystals of greenockite are interesting from their polar development, being combinations of the lower base with the hexagonal prism of the second order, terminated above with a series of hexagonal pyramids of the second order and a

small basal plane. It is isomorphous with wurtzite, the fibrous zinc sulphide; used in the spintharoscope to demonstrate the radiations of radium.

It occurs in the Joplin region of Missouri as a yellow coating on crystals of calcite and sphalerite. The yellow smithsonite of Arkansas, or "turkey-fat ore," owes its color to an admixture of greenockite; it also occurs in small quantities with zinc minerals at Friedensville, Pennsylvania, and as a furnace product.

Artificial crystals of greenockite have been obtained by fusing cadmium sulphide, sulphur, and potassium carbonate, or from a hot solution of cadmium sulphide in ammonium sulphhydrate, which deposits crystals of greenockite on cooling.

MILLERITE

Millerite. — Capillary pyrite; Hair sulphide; NiS , sulphide of nickel; $\text{Ni} = 64.6$, $\text{S} = 35.3$; Hexagonal; Type, Ditrigonal Polar (?), $c = .9883$; $0001_A 11\bar{2}1 = 48^\circ 46'$; $H. = 3-3.5$; $G. = 5.3-5.65$; Color, bronze-yellow; Streak, greenish black; Luster, metallic.

B.B. — On coal in the O. F. blackens, fuses to a globule, and yields a sulphur dioxide odor. Well roasted, the black oxide reacts for nickel with the fluxes; it may contain iron, cobalt, or copper, all of which will interfere with the bead reactions.

General description. — In very slender elongated crystals or hairlike tufts, often interwoven and matted, as at Antwerp, New York, where it occurs in cavities of hematite. It often forms botryoidal crusts with a radiated structure, as at the Gap mine, Lancaster County, Pennsylvania; here it is associated with a granular pyrrhotite. Very fine tufts of the hairlike variety are found in cavities of calcite and dolomite near St. Louis, Missouri.

Nickel, as is shown by the analyses of rocks made by the United States Geological Survey, is a very common constituent of igneous rocks, though as a very minor accessory mineral, amounting to .027 per cent. It is to the concentration of this trace of nickel that the occurrence of millerite in veins and cavities is due.

Beryrichite, Ni_3S_4 , and polydymite, Ni_4S_5 are rare, though they may be formed under nearly the same conditions as millerite.

Millerite, from its restricted occurrence, though rich in nickel, is of minor importance as a nickel ore.

PYRRHOTITE

Pyrrhotite. — FeS , $\text{Fe}_n\text{S}_{n+1}$; Magnetic sulphide of iron; $\text{Fe} = 61.6$, $\text{S} = 38.4$; Hexagonal; Type, Ditrigonal or Dihexagonal Polar (?) $\dot{c} = 0.7402$; $0001 \wedge \frac{1120}{1071} = 45^\circ 7'$; Common forms, $c(0001)$, $m(10\bar{1}0)$, $s(10\bar{1}1)$; Twinning plane s ; Cleavage, c distinct, a less so; Brittle, fracture uneven; $H. = 3.5-4.5$; $G. = 4.58-4.64$; Color, bronze-yellow; Streak, grayish black; Luster, metallic; Magnetic.

B.B. — In O. F. on coal yields sulphur dioxide and in R. F. blackens and becomes strongly magnetic. Yields an iron reaction with the fluxes; some may show cobalt, nickel, or copper. Dissolves in hot HCl, yielding hydrogen sulphide.

General description. — Usually massive with a distinct parting, granular, or disseminated. Crystals are rare, generally small six-sided tablets, combinations of the base and a prism; the prism faces are horizontally striated. Other forms have been described as a series of pyramids, but are unusual in occurrence. Artificial crystals show a polar development. Pyrrhotite darkens on exposure, often iridescent, easily oxidizing to hematite or limonite.

Chemical analyses show a great variation in the proportions of iron and sulphur, there being more sulphur than is required for the formula FeS by an amount equal to an atom of sulphur in excess; from this it has been suggested that the series may be represented by the formula $\text{Fe}_n\text{S}_{n+1}$, commonly $\text{Fe}_{11}\text{S}_{12}$, though analyses show a variation from Fe_5S_6 to $\text{Fe}_{16}\text{S}_{17}$ in the natural mineral. Both nickel and cobalt may form an analogous series of sulphides, as in each case minerals related in the same manner have been described, while pyrrhotite contains small quantities of these metals, and in fact the larger portion of the nickel of commerce is derived from pyrrhotite. When the percentage of nickel is above 6 per cent., the mineral is known as pentlandite $(\text{FeNi})\text{S}$.

Troilite, FeS , is the massive ferrous sulphide occurring in meteorites. Pyrrhotite may occur as a magmatic segregation, as is the case of the Norway deposits, or as a minor accessory, connected with gabbro, diorite, basalts, and norites, or with other ferromagnesian rocks. Such magmas dissolve sulphides which on solidification separate very early, a process somewhat analogous to the formation of a matte in the smelting furnace. The large deposits at Ducktown, Tennessee, and at Sudbury, Ontario, are impregna-

tions, though it may be said there is great doubt of this in case of the Sudbury deposit. In these localities pyrrhotite is associated with pyrite, chalcopyrite, and other minerals, which are the results of oxidation. Pyrrhotite may also result from pneumatolytic action, as by the interaction of hydrogen sulphide and ferric chloride.

In addition to the localities mentioned above, pyrrhotite occurs at Standish, Maine, in crystals; in Essex County, New York; at the Gap mine, Pennsylvania; in North Carolina and Virginia; large tabular crystals are obtained from Minas Geraes, Brazil.

Artificially pyrrhotite may be formed by the reaction of H_2S on iron at a high temperature and under pressure; in the wet way by heating a solution of $FeCl_3$, Na_2CO_3 , and H_2S , for a considerable time at $200^\circ C.$ in a closed tube with all air excluded, otherwise pyrite will form; also by the action of H_2S on slightly acid solutions of ferrous salts containing some ferric salts between the temperatures of 80° and 225° .

NICCOLITE

Niccolite. — Copper nickel; $NiAs$, Arsenide of nickel; $Ni = 43.9$, $As = 56.1$; $0001 \wedge 10\bar{1}1 = 43^\circ 25'$. Hexagonal; Type, Hexagonal Polar (?) $c = 0.8194$; Common forms, c (0001), m (1011); Cleavage, doubtful; Brittle, fracture uneven; $H. = 5-5.5$; $G. = 7.33-7.67$; Color, pale copper-red; Streak, brownish black; Luster, metallic.

B.B. — Fuses easily on coal to a brittle globule and yields an arsenical odor, with fumes of As_2O_3 and possibly a white coat of oxide. Well roasted and treated with borax on coal yields a persistent nickel reaction. Soluble in hot nitric acid.

General description. — Crystals very rare, usually massive or disseminated; when fresh, the color is very characteristic but tarnishes to black. Isomorphous with $CoAs$, $NiSb$, and $FeAs$, all of which it may contain in small quantities, and these metals will show in the first portions of borax when testing on coal for the bead colorations.

Breithauptite, $NiSb$, is the very similar antimony compound associated with niccolite at the mines at Freiberg, Saxony; Andreasberg in the Harz; and at Cobalt, Ontario. At the latter locality there is a remarkable deposit of cobalt, nickel, and silver ores, filling veins, fissures, and the joints in a metamorphosed rock

and in diabase, with a gangue of calcite. The associated minerals are niccolite, chloanthite, millerite, cobaltite, smaltite, argentite, dyscrasite, pyrargyrite, arsenopyrite, with other oxidized ores and native silver in the superficial areas. These minerals have either been concentrated from the near-by diabase or carried up from depths by warm solutions. In addition to the localities mentioned, niccolite occurs at Chatham, Connecticut; Franklin, New Jersey; Silver Cliff, Colorado; and Tilt Cove, Newfoundland.

BORNITE

Bornite. — Purple copper ore; Horseflesh ore; Cu_3FeS_3 ; Cu = 55.5, Fe = 16.4, S = 28.1; Isometric; Type, Ditesseral Central; Common forms, *o* (111), *d* (110), *n* (211); Twinning plane, 111; Cleavage, octahedral in traces, slightly sectile; Fracture, conchoidal; H. = 3; G. = 4.9–5.4; Color, copper-red to brown, iridescent from tarnish; Streak, grayish black; Luster, metallic, opaque.

B.B. — Fuses easily on coal in the R. F. to a magnetic globule. In the O. F. yields a sulphur dioxide odor; well roasted and reduced with soda yields malleable copper buttons. Soluble in hot nitric acid.

General description. — Crystals are very rare, cubic or octahedral in habit, but are rough and irregular; the usual occurrence is massive, granular, or disseminated.

Bornite occurs as a primary magmatic constituent of igneous rocks, but more often in veins and fissures of contact zones, as well as impregnations and replacements, associated with other metallic sulphides. It oxidizes easily in the superficial areas, forming carbonates, etc., or is carried down in solution as sulphates.

Bornite next to chalcopyrite and chalcocite is the most important copper ore; it forms the greater bulk of the ore in the Copper River region, Alaska; also in quantity at Butte, Montana, and in nearly all copper mining districts.

CHALCOPYRITE

Chalcopyrite. — Copper pyrite, CuFeS_2 ; sulphide of copper and iron; Cu = 34.5, Fe = 30.5, S = 35.0; Tetragonal; Type, Ditetragonal Alternating; *c* = .9852; Common forms, $\pm P$ (111), *c* (001), *m* (110) *r* (332), *z* (201); Twinning plane, 111 and 110; Cleavage, at times distinct; Brittle, fracture uneven; H. = 3.5–4;

G. = 4.1–4.3; Color, brass-yellow, often tarnished and iridescent; Streak, greenish black; Luster, metallic.

B.B. — In R. F. on coal fuses to a magnetic globule and in O. F. yields an odor of sulphur dioxide. Well roasted and reduced with soda, yields malleable copper buttons. Soluble in hot nitric acid.

General description. — Crystals are not uncommon as simple sphenoids or combinations of the sphenoid, base, and prism. The axial ratio being so near unity these sphenoids have the appearance of tetrahedrons; such simple forms are found in the Joplin region,



FIG. 401. — Chalcopyrite and Sphalerite on Dolomite. Aurora, Missouri.

Missouri, on dolomite associated with sphalerite and galena. Other sphenoids both obtuse and acute have been described, and the appearance of the crystal will depend upon which is the predominating form; the tetragonal trapezohedron ω (576) occurs on crystals from French Creek, Pennsylvania. Twins in which the twinning axis is **P**, both contact and penetrating, occur; other twins are rare.

Chalcopyrite is present in all copper mines, especially in the zone below oxidation, and is very widely distributed in other mines;

it is the most important of the copper ores. Its copper content, however, varies greatly from an admixture of pyrite.

Some deposits have arisen from magmatic segregation, and then it is associated with other sulphides, as pyrite, bornite, or pyrrothite; as a primary mineral it is disseminated through the ferromagnesian igneous rocks, especially those containing pyroxene or hypersthene. It is these primary sulphides which furnish the copper of the secondary deposits, in veins, etc. Of the products of oxidation, derived from chalcopyrite, the sulphates of iron and copper are very soluble and may be transported in solution to be reprecipitated again, either close at hand or at a distance according to local conditions, as chalcopyrite or in some other form. These solutions may flow down along the veins from which the sulphates originated, to be precipitated at lower levels by hydrogen sulphide, pyrite, or other sulphides, yielding the more valuable ores of the area of secondary enrichment. In this way pyrite used in the Copper Queen mine, in the early days, to fill stopes is being mined at the present time, it having accumulated nearly 12 per cent copper. Chalcopyrite is present in nearly all ore veins contained in metamorphic or sedimentary rocks and limestones; also reported in furnace slags, indicating its formation by dry fusion at ordinary pressures, analogous to its artificial formation in a simple fusion of pyrite and copper sulphide.

STANNITE

Stannite. — $\text{Cu}_2\text{FeSnS}_4$; Tin pyrite; Cu = 29.5, Sn = 27.5; Fe = 13.1, S = 29.9; Tetragonal; Type, Ditetragonal Alternating; $c = .986$; Crystals sphenoidal, very rare; Cleavage, indistinct; Brittle, fracture uneven; H. = 4; G. = 4.3–4.52; Color, steel-gray to iron-black; Streak, black; Luster, metallic.

B.B. — On coal fuses and yields a white coat (SnO_2) and a sulphur dioxide odor. Roasted and reduced with soda, yields malleable buttons which react with the fluxes for copper. Soluble in hot nitric acid, yielding a blue solution and a white residue of tin oxide and sulphur.

General description. — Crystals have been described from Bolivia; its usual occurrence is massive, granular, or disseminated, variable in composition owing to the admixture of other sulphides as chalcopyrite. Stannite is associated with cassiterite in the Corn-

wall mines, in Bolivia, Zinnwald, and the Black Hills, South Dakota. It is not a common mineral, and, while it contains considerable tin and copper, owing to its restricted occurrence it is of minor importance as an ore.

PYRITE

Pyrite. — FeS_2 ; Disulphide of iron; Fe = 46.6, S = 53.4; Isometric; Type, Tesseral Central; Common forms, *a* (100), *o* (111), *e* (120), *s* (312); Twinning supplementary and interpenetrating; Cleavage, *a* and *o* distinct; Brittle, fracture conchoidal to uneven; H. = 6–6.5; G. = 4.5–5.1; Color, light brass yellow; Streak, greenish to brownish black; Luster, metallic, often brilliant.

B.B. — On coal in O. F., yields a sulphur dioxide odor, darkens, and in R. F. becomes magnetic. With the fluxes reacts for iron. In the closed tube yields a sublimate of sulphur. Soluble in hot nitric acid.

General description. — Crystals are very common of cubic, octahedral, or pentagonal dodecahedral habit, or combinations of these three forms. Numerous other forms, including all seven forms of the type, have been described, as on crystals from Gilpin County, Colorado. The cube and pyritohedral faces are usually striated parallel to their intersection; on the cube the striations are parallel to the opposite sides and at right angles to the striations on adjacent faces, indicating the hemihedral symmetry of the pyrite cube. Penetrating supplementary twins of the plus and minus pyritohedrons are obtained at Minden, Prussia; complex stellate and parallel growths are common in clays, slates, and argillites. A peculiar elongated octahedral form, possibly a tetragonal phase, occurs at French Creek, Pennsylvania. Beautiful crystals are obtained from the Isle of Elba, from Peru, and from French Creek, Pennsylvania. Pyrite also occurs massive, granular, or in nodules.

Chemically pyrite may contain copper, nickel, and cobalt sulphides as mixtures, as well as arsenic and metallic gold. It is the most widely distributed of all the sulphides, occurring under the most varied conditions; as primary constituent of igneous rocks and secondary impregnations, in sedimentary rocks, clays, and coal formations, as well as filling veins, fissures, and joints, where it is associated with other sulphides, carbonates, sulphates, and oxides. By oxidation it yields sulphates, acid sulphites, and sulphuric acid,

all of which are soluble in water and when in solution react both as solvents and reducing agents, attacking other minerals. The ultimate result or products of oxidation are the hydroxides of iron, limonite and göthite, and the oxide hematite, all of which often

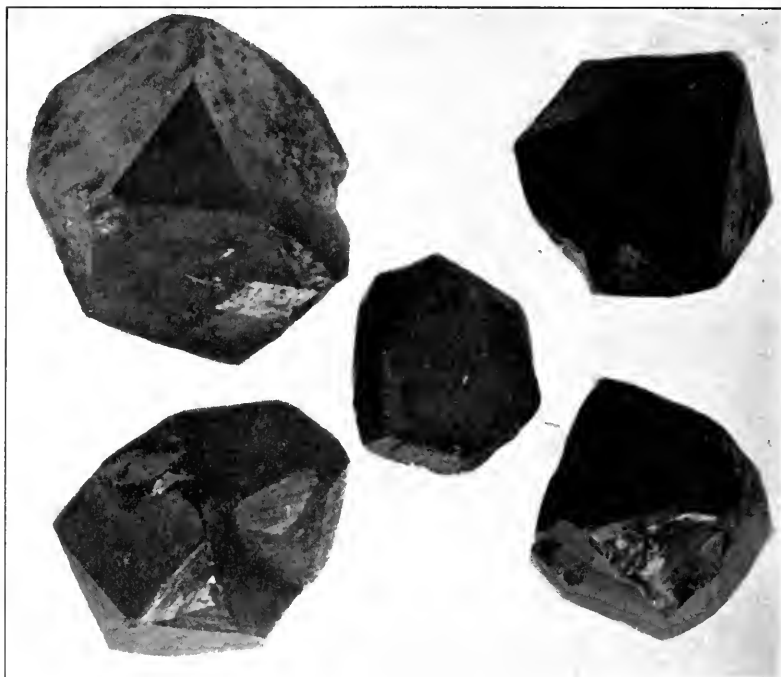

FIG. 402. — Pyrite Crystals.

occur as pseudomorphs after pyrite. Secondary pyrite is formed from the sulphates of iron carried in the circulating ground waters; the organic matter contained in shales, coal, and fossils reduces these solutions and the iron is precipitated as pyrite.

Pyrite is mined commercially at Davis, in the Berkshire Hills, Massachusetts, where it is found in a crystalline schist; in St. Lawrence County, New York; these deposits are associated with limestone and schist. In Eastern Virginia large lenses of pyrite occur associated with chalcopyrite, sphalerite, galena, and pyrrhotite; these deposits yield one half of the quarter of a million tons produced in the United States annually. It is also mined in smaller quantities in Georgia, Alabama, and California. All the pyrite mined is used in the production of sulphuric acid. Pyrite may be

formed artificially by gently heating FeS with sulphur, or by passing H₂S over oxides and chlorides of iron, heated to redness; also by heating the mixture of ferric oxide, sulphur, and ammonium chloride slowly to a temperature above which the latter volatilizes, when cubes and octahedrons of pyrite will form. Pyrite is also formed by the action of H₂S on ferric sulphate, as in marcasite, but from neutral or slightly acid solutions.

SMALTITE

Smaltite. — Diarsenide of cobalt, CoAs₂; Co = 28.2, As = 71.8; Isometric; Type: Tesseral Central; Common forms, **a** (100), **o** (111), **d** (110), **e** (210); Twinning plane, 111, composition face, 211; Cleavage, 111 distinct, **a** in traces; Brittle, fracture uneven; H = 5.5-6; G. = 6.4-6.6; Color, tin-white; Streak, gray-black; Luster, metallic.

B.B. — On coal easily fusible, yielding a magnetic globule and an arsenic odor, may yield a white coat of As₂O₃. With borax shows persistent cobalt reactions. Soluble in hot nitric acid.

General Description. — Habit like pyrite, but well-developed crystals are rare; more often massive with the surface darkened from tarnish. It may contain both iron and nickel, as the corresponding diarsenide of nickel, chloanthite, is isomorphous with cobaltite; the two species grade into each other. Safflorite is an orthorhombic form of CoAs₂ occurring at Tunaberg, Sweden.

Skutterudite, CoAs₃, is a triarsenide from Modun, Norway, also isometric. Smaltite occurs in veins associated with other ores of cobalt, nickel, iron, and silver; the most noted locality of America is at Cobalt, Ontario. The historic European localities are Freiberg, Saxony; Joachimsthal, Bohemia; and Tunaberg, in Sweden.

CHLOANTHITE

Chloanthite. — Diarsenide of nickel; NiAs₂; Ni = 28.1, As = 71.9; Common forms, **a** (100), **o** (111), **d** (110), **e** (210); Twinning plane, 111; Cleavage, 111 distinct, **a** in traces; Brittle, fracture uneven; H. = 5.5-6; G. = 6.4-6.6; Color, tin-white; Streak, gray-black; Luster, metallic.

B.B. — Fuses easily on coal to a globule and yields an arsenic odor, with possibly a white coat of As₂O₃. Roasted and treated with borax yields a persistent nickel reaction. It may contain considerable cobalt.

General Description. — Crystalline habit, occurrence, and association like smaltite, often coated with the green nickel arsenate, annabergite, $\text{Ni}_2(\text{AsO}_4)_3$, an oxidation product.

Rammelsbergite is an orthorhombic form of NiAs_2 occurring very sparingly at Schneeberg, Saxony.

COBALTITE

Cobaltite. — Sulpharsenite of cobalt, CoAsS ; Co = 35.5, As = 45.2, S = 19.3; Isometric; Type, Tesseral Central; Common forms, c (100), o (111), e (120); Cleavage, cubic; Brittle, fracture uneven; H. = 5.5–6; G. = 6–6.3; Color, reddish to silver-white; Streak, grayish black; Luster, metallic.

B.B. — Fuses easily on coal to a magnetic globule and yields an arsenic odor and sulphur dioxide fumes. Well roasted and treated with borax yields a cobalt reaction. Soluble in hot nitric acid, which after diluting yields a white precipitate with BaCl_2 (BaSO_4).

General description. — Crystals are cubes and pyritohedrons, or combinations of these two forms. In habit very much like pyrite, with similar striations on the crystal faces; crystals are much more common than those of the two preceding species; often massive, granular, and disseminated. Occurs under similar conditions and associations as smaltite.

Gersdorffite, sulpharsenide of nickel, NiAsS , is similar in habit, occurrence, and association to cobaltite, with which it is isomorphous.

ULLMANNITE

Ullmannite. — Sulph-antimonite of nickel, NiSbS ; Ni = 27.8, Sb = 57.0, S = 15.2; Isometric; Type, Tesseral Polar; Forms, a (100), \pm e (120), d (110), \pm o (111); Twins, interpenetrating tetrahedrons; Cleavage, cubic perfect; Brittle, fracture uneven; H. = 5–5.5; G. = 6.2–6.7; Color, steel-gray to silver-white; Streak, grayish black; Luster, metallic.

B.B. — On coal in R. F. fuses easily to a globule, boils, and yields an antimony coat. After roasting yields a nickel reaction with the fluxes. Decomposed with hot nitric acid with the separation of sulphur and white oxide of antimony. It may contain some arsenic.

General Description. — Crystals from Sarrabus, Sardinia, are combinations of the cube, rhombic dodecahedron, and the pyritohedron; while crystals from Lölling in Carinthia are tetrahedral in habit, combinations of the tetragonal and trigonal tristetrahedrons with the plus and minus tetrahedrons and the rhombic dodecahedron. Chemically the two are alike and therefore must be tetartohedral in symmetry, as in that type only can all these forms occur.

Ullmannite is a rare mineral and its principal interest is as a representative of tetartohedral symmetry in the isometric system.

MARCASITE

Marcasite. — Disulphide of iron, FeS_2 ; Fe = 46.6, S = 53.4; Orthorhombic; Type, Didigonal Equatorial; $a : \bar{b} : c = .7662 : 1 : 1.2342$; $100 \wedge 110 = 37^\circ 27'$, $001 \wedge 101 = 58^\circ 10'$, $001 \wedge 011 = 50^\circ 59'$, $111 \wedge \bar{1}11 = 66^\circ 7'$; Common forms, c (001), 1 (011), e (101), m (110); Twinning planes, 110 and 101; Cleavage, m distinct, l less so; Brittle, fracture uneven; H. = 6–6.5; G. = 4.85–4.9; Color, light bronze yellow; Streak, gray; Luster metallic.

B.B. — Fuses easily on coal and blackens, yielding a sulphur dioxide odor in O. F. In R. F. becomes magnetic and reacts for iron with the fluxes.

General Description. — Crystals when simple are tabular parallel to the base; it is more often twinned, with the prism face the composition plane, which twinning is often repeated to fivefoldings with a pentagonal outline and concentric striations; this method of twinning forms the spearhead pyrites of the Dover Cliffs, England. Twins with the macrodome as the composition face are not so common; also, radiated, encrusted, stalactitic, and reniform.

Marcasite is dimorphous with pyrite. It is always a secondary mineral found in sedimentary rocks, or associated with coal beds and organic matter; how its molecule differs from that of pyrite has not been determined; marcasite has been represented as a

ferrous sulphide, $\text{Fe} \begin{matrix} \text{S} - \text{S} \\ \text{S} - \text{S} \end{matrix} \text{Fe}$, and pyrite as a ferriferous sul-

phide, $\text{Fe} \begin{matrix} \text{S} - \text{S} \\ \text{S} - \text{Fe} - \text{S} \\ \text{S} - \text{S} \end{matrix} \text{Fe}$. This conclusion has been reached

by a consideration of the amount of iron yielded by their de-

composition, in the ferrous and ferric states. Marcasite oxidizes more readily than pyrite, yielding ferrous sulphate and sulphuric acid; the ferrous sulphate appears as a white efflorescence, and the specimen swells, cracks, and falls to pieces. Marcasite is the less stable form and passes into pyrite. Their ultimate oxidation products are the same. At 450° marcasite passes over to pyrite with an evolution of heat; this probably explains the absence of marcasite as a primary constituent of igneous rocks.

Marcasite has been formed artificially by the slow action of H₂S on ferric sulphate or chloride at several temperatures up to 300°. Acidity favors the formation of marcasite, for when the solution is neutral, pyrite is formed. The amount of pyrite mixed with marcasite formed under these conditions decreases with the acidity. The favorable conditions for the formation of nearly pure marcasite is 100° and 1.18 per cent. of free H₂SO₄.

ARSENOPYRITE

Arsenopyrite. — Mispickel, FeSAs; Sulpharsenide of iron; Fe = 34.3, As = 46, S = 19.7; Orthorhombic; Type, Didigonal Equatorial; $\check{a} : \bar{b} : \check{c} = .6773 : 1 : 1.1882$; $100 \wedge 110 = 34^\circ 6'$, $001 \wedge 101 = 60^\circ 19'$, $001 \wedge 011 = 49^\circ 54'$; Common forms, **m** (110) \wedge **u** (014), **e** (101) **q** (011); Twinning plane, 110, also 101, both contact and interpenetrating; Cleavage, **m** distinct, **c** faint traces; Brittle, fracture uneven; H. = 5.5–6; G. = 5.9–6.2; Color, silver-white to steel-gray; Streak, grayish black; Luster, metallic.

B.B. — On coal fuses easily to a brittle globule and yields an arsenic odor and sulphur dioxide fumes; roasted and treated in the borax bead yields an iron reaction; in the closed tube yields first an arsenious sulphide sublimate and then a metallic mirror of arsenic.

General description. — Crystals are prismatic combinations of the unit prism with the unit domes, the prism zone striated; at times the prism is very short when the crystal is pyramidal in appearance. Twinning is of two classes, those in which the composition face is **m**, often repeated, yielding pseudo-hexagonal forms, as in marcasite, or the dome **e** is the composition face; as the angle **e** \wedge **e'** is 120° 38', the individuals when repeated form a six-armed star. Arsenopyrite is very often massive, granular, or compact; some

iron is usually replaced by cobalt as the corresponding sulpharsenide of cobalt, glaucodot (CoFeSAs), is an isomorphous compound.

Arsenopyrite occurs as a constituent of pegmatites, in the deep-seated and intermediate veins, especially those in metamorphic schists and serpentine, where it is associated with chalcopyrite, pyrite, sphalerite, and the arsenides of cobalt and nickel, as well as with gold or silver minerals. By oxidation it yields arsenates which

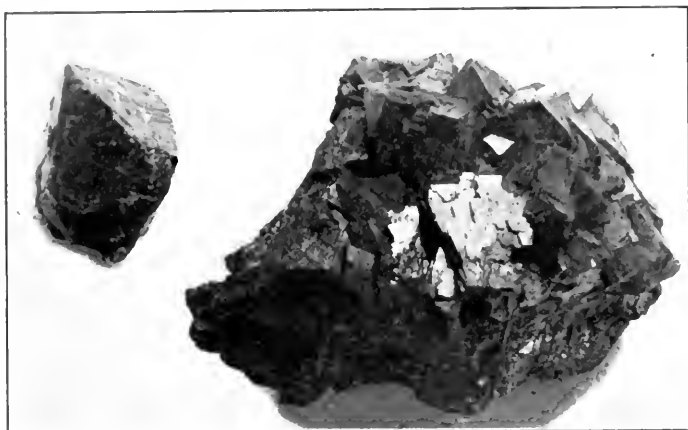

FIG. 403. — Arsenopyrite from Freiberg, Saxony.

form a series of minerals characteristic of the zone of oxidation; or, being soluble in this form, the arsenic may be carried away in solution; some mine waters and indeed the waters of some natural springs contain arsenic in such quantities as to be highly poisonous.

Complex crystals occur at Franconia, New Hampshire; simple combinations at Tavistock, Devonshire. Arsenopyrite is mined commercially, for the arsenic it contains, at several places in Virginia and in the state of Washington; but as it is associated with gold, silver, and copper ores, most of the commercial arsenic is recovered from the flue dust of smelters using such ores.

CHAPTER VI

SULPHO COMPOUNDS

ZINKENITE

Zinkenite. — Sulphantimonide of lead, PbSb_2S_4 ; Pb = 35.9, Sb = 41.8, S = 22.3; Orthorhombic; Type, Didigonal Equatorial; $\check{a} : \bar{b} : \check{c} = .5575 : 1 : .6353$; $100 \wedge 110 = 29^\circ 8'$, $001 \wedge 101 = 48^\circ 44'$, $001 \wedge 011 = 32^\circ 25'$; Crystal forms, **e**(102), **k**(061); Cleavage, none; Brittle, fracture uneven; H. = 3–3.5; G. = 5.3–5.35; Color and streak, steel-gray; Luster, metallic.

B.B. — Fuses easily in R. F., yielding an antimony coat, and with von Kobell's flux shows lead; also yields a sulphur reaction when fused with soda. Dissolves in hot HCl, yielding H_2S and white lead chloride. Crystals are columnar with faces indistinct and striated lengthwise, or fibrous, also massive.

General description. — Zinkenite is a member of a series of minerals which may be represented by the general formula $\text{R}''\text{S}$, $\text{R}_2'''\text{S}_3$, in which R'' may be lead, copper, or iron and R''' may be antimony, arsenic, or bismuth. They are all very similar in their physical properties and crystalline habit, and as they are isomorphous, grade into each other.

Sartorite, PbAs_2S_4 , and galenobismuthite, PbBi_2S_4 , are the lead members. Emplectite, $\text{Cu}_2\text{Bi}_2\text{S}_4$, and chalcostibite, CuSb_2S_4 , are the copper members; and berthierite, FeSb_2S_4 , is the iron member of the series. Berthierite is the most common of the group. On coal it fuses easily, yielding an antimony coat, sulphur dioxide odor, and a magnetic residue. It occurs fibrous, plumose, or massive with cleavage.

JAMESONITE

Jamesonite. — $\text{Pb}_2\text{Sb}_2\text{S}_5$; Pb = 50.8, Sb = 29.5, S = 19.7; Orthorhombic; Type, Didigonal Equatorial; $\check{a} : \bar{b} : \check{c} = .819 : 1 : ?$; Cleavage, basal perfect; Brittle, fracture uneven; H. = 2–3; G. = 5.5–6; Color, steel-gray; Streak, grayish black; Luster, metallic.

B.B. — Like zinkenite.

General description. — Jamesonite is a representative of a series of isomorphous lead and silver minerals; they are generally not well crystallized, and resemble each other so closely that in many cases they are to be distinguished only by chemical analysis. They are not common in occurrence, and are associated with other sulphides and arsenides in ore deposits.

BOURNONITE

Bournonite. — $(\text{Cu}_2 \cdot \text{Pb})_3\text{Sb}_2\text{S}_6$; Cu = 13, Pb = 42.5, Sb = 24.7, S = 19.8; Orthorhombic; Type, Didigonal Equatorial; $\tilde{a} : \tilde{b} : \tilde{c} = .9379 : 1 : .8968$; $100 \wedge 110 = 43^\circ 10'$, $001 \wedge 101 = 43^\circ 43'$, $001 \wedge 011 = 41^\circ 53'$; Forms, **a** (100), **b** (010), **c** (001), **n** (011), **o** (101), **m** (110); Twinning-plane, **m**; Cleavage **b** distinct, **a** and **c** less so; H. = 2.5-3; G. = 5.7-5.9; Brittle, fracture uneven; Color and streak gray to iron-black; Luster, metallic.

B.B. — Fuses easily on coal, yielding a white coat of antimony trioxide; on continued heating yields a yellow coat (lead). The residue reduced with soda yields copper buttons or reacts for copper with the fluxes.

General description. — Crystals tabular parallel to the base, with the short prism faces striated parallel to the vertical axis. Often twinned with the prism as the composition face, when repeated forming the characteristic cogwheel-shaped aggregates, as at Kopnik, Hungary, where it is known as wheel ore. The best crystals are from the Harz, Germany. Also massive, granular, or compact.

Occurs in the United States in Yavapai County, Arizona; Montgomery County, Arkansas; and in several localities in Colorado. It is an important ore of lead and copper, but only locally.

BOULANGERITE

Boulangerite. — $\text{Pb}_3\text{Sb}_2\text{S}_6$; Pb = 58.9, Sb = 22.8, S = 18.3; Orthorhombic; Type, Didigonal Equatorial; $\tilde{a} : \tilde{b} : \tilde{c} = .5527 : 1 : .7478$; Crystal forms, rare; Brittle, fracture uneven; H. = 2.5-3; G. = 5.75-6; Color, bluish lead-gray; Streak, black; Luster, metallic, dull.

B.B. — The same as zinkenite.

General description. — Crystals very rare, usually fibrous, plumose, granular, or compact. Often with yellow spots of oxide of antimony on the surface.

Occurs at Příbram, Bohemia; in the Harz; and in the Echo district, Nevada. It is an ore of lead, but too rare to be of much importance.

PYRARGYRITE

Pyrargyrite. — Dark ruby silver; Sulphantimonide of silver, $\text{Ag}_3\text{Sb}_2\text{S}_3$; Ag = 59.9, Sb = 22.3, S = 17.8; Hexagonal; Type, Ditrigonal Polar; $\epsilon = 0.7891$; $0001 \wedge 10\bar{1}1 = 42^\circ 20'$, $e \wedge e' = 42^\circ 5'$, $r \wedge r' = 71^\circ 22'$, $v \wedge v' = 74^\circ 25'$; Forms, a ($11\bar{2}0$), m ($10\bar{1}0$), e ($01\bar{1}2$), r ($10\bar{1}1$), v ($21\bar{3}1$); Twinning plane, $11\bar{2}0$ also $10\bar{1}4$ quite common, $10\bar{1}1$ or $10\bar{1}2$ rare; Cleavage, r distinct, e less so; Brittle, fracture conchoidal; H. = 2.5; G. = 5.77–5.86; Color, grayish black to black; Streak, purplish red; Luster, adamantine; Nearly opaque, deep red in thin splinters; $\omega = 3.084$, $\epsilon = 2.881$, $\omega - \epsilon = .203$; Optically (—).

B.B. — Fuses easily on coal to a globule and yields a white coat of antimony trioxide. In R. F. or with soda yields a malleable button of silver. Soluble in nitric acid with the separation of sulphur and insoluble oxide of antimony. In the closed tube yields a red sublimate.

General description. — Crystals usually quite complicated both through twinning and the complexity of the forms. A large number of forms have been described, but as formerly pyrargyrite and proustite were considered one and the same species, their individual forms have not as yet been entirely separated. Doubly terminated crystals are not common, but when they do occur they are generally supplementary twins with the basal plane as the composition face, in which case the two terminations are similar. The polarity of its symmetry is shown by the striations on the prism faces, which are not symmetrical to the basal plane. Also occurs compact, granular, or disseminated.

Pyrargyrite occurs in veins associated with other silver minerals, as argentite, proustite, or native silver, with sulphides and arsenides; calcite, barite, fluorite, or quartz are the gangue minerals. In such cases it has been produced by the interaction of antimonides on silver, in solution, either by precipitation or replacement at comparatively low temperatures, which also its synthesis in the laboratory would indicate. Often alters to argentite and forms pseudomorphs after native silver.

Pyrrargyrite is an important ore of silver occurring in most silver mines, as at Andreasberg and Freiberg, Saxony; at Příbram, Bohemia; Kongsberg, Norway; at various localities in Chili and Mexico. In the United States in the Ruby district, Colorado, associated with tetrahedrite; in the Poorman's Lode, Idaho, in large masses; also in Arizona and New Mexico. Artificially formed by precipitating a solution of silver with potassium sulph antimonate; this precipitate is amorphous, but if mixed with sodium carbonate and heated in a sealed tube above 80° the product becomes crystalline.

PROUSTITE

Proustite. — Light ruby silver; Ag_3AsS_3 ; $\text{Ag} = 65.4$, $\text{As} = 15.2$, $\text{S} = 19.4$; Hexagonal; Type, Ditrigonal Polar; $c = .8039$, $0001 \wedge 10\bar{1}1 = 42^{\circ} 51'$, $e \wedge e' = 42^{\circ} 46'$, $v \wedge v' = 74^{\circ} 39'$, $r \wedge r' = 72^{\circ} 12'$; Forms, $a(11\bar{2}0)$, $e(01\bar{1}2)$, $r(10\bar{1}1)$, $m(10\bar{1}0)$, $(21\bar{3}1)$; Twinning plane, $u(10\bar{1}4)$ and $r(10\bar{1}1)$ common, e and c rare; Cleavage, r distinct; Brittle, fracture conchoidal; $H. = 2-2.5$; $G. = 5.57-5.64$; Color and streak, scarlet; Transparent to translucent, becoming black on exposure; $\omega = 3.087$, $\epsilon = 2.792$, $\omega - \epsilon = 0.295$; Optically (-).

B.B. — On coal in R. F. fuses easily and yields an arsenic odor and sulphur fumes, may yield a white coat of arsenic trioxide. Reduced with soda yields a globule of malleable silver. Soluble in nitric acid with the separation of sulphur.

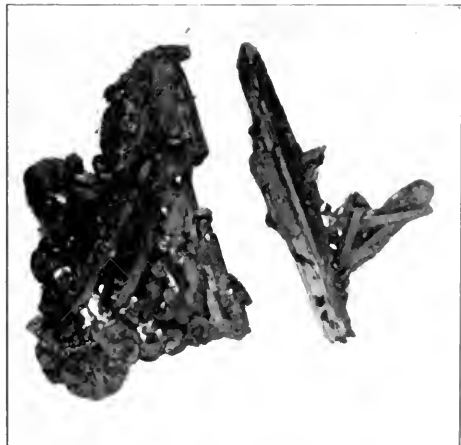

FIG. 404. — Proustite. Freiberg, Saxony.

General Description.

— Crystals elongated and terminated by the scalenohedron v , or the rhombohedron e . Proustite is isomorphous with pyrrargyrite and resembles it in every respect except in its light color and in its streak. Fresh specimens are very beautiful, but soon lose their ruby color and become dark and opaque unless protected from the light.

It occurs with pyrargyrite in the same localities and under the same conditions.

TETRAHEDRITE

Tetrahedrite. — Cu_3SbS_3 ; Sulphantimonide of copper; $\text{Cu} = 46.8$, $\text{Sb} = 29.6$, $\text{S} = 23.6$; Isometric; Type, Ditesseral Polar; Common forms, $\pm o$ (111), d (110), n (211); Twinning plane, 111; Cleavage, none; Brittle, fracture subconchoidal; $H. = 3-4.5$; $G. = 4.4-5.1$; Color, lead-gray to iron-black; Streak, brown to iron-black; Luster, metallic; Opaque.

Tennantite, Cu_3AsS_3 ; Sulpharsenide of copper. The isomorphous arsenide is similar in crystallization and appearance and often mixed with the antimonide.

B.B. — Fuses easily in R. F. on coal, yielding a white coat of either Sb_2O_3 or As_2O_3 as the case may be; in O. F. yields a sulphur dioxide odor. The coat may contain either lead or zinc oxide if either of these metals is present. Well roasted and reduced with soda yields malleable copper buttons which may be quite white in color from the presence of lead or silver. When mercury is present, the powdered mineral when heated in the closed tube with dry soda will yield a sublimate of small globules of metallic mercury. Decomposed in hot nitric acid with the separation of sulphur and oxide of antimony.

General description. — Crystals are well-developed combinations of the plus and minus tetrahedrons, modified by the trigonal



FIG. 405. — Tetrahedrite on Dolomite. Clausthal, Harz.

and tetragonal trisoctahedrons, usually striated or furrowed parallel to the tetrahedral edges; such crystals are found at Kapnik, Hungary, associated with chalcopyrite, pyrite, and sphalerite. At Clausthal, Harz, the simple trigonal tristetrahedron, the

tetrahedron, or combinations of these two forms, also penetrating supplemental tetrahedral twins, with the perpendicular to 111 as the twinning axis, occur, in veins in a dolomite associated with chalcopyrite crystals and quartz. In crystalline habit tennantite is more apt to be rhombic dodecahedral, with small modifications of the tetrahedrons, as at Redruth in Cornwall, England. Both occur massive, granular, or compact.

Chemically tetrahedrite may be represented by the formula $R''_3R'''S_3$, in which R'' is mostly copper, but often replaced in part by silver, lead, mercury, zinc, or iron, and R''' represents antimony, arsenic, or bismuth. These substitutions lead to numerous local variations and possibly when not well crystallized to confusion with other minerals of the same nature. It is often an important silver ore, as the variety freibergite, while schwartzite is the mercurial form.

Tetrahedrite occurs as a vein mineral associated with sulphides, arsenides, and antimonides in the silver districts of Mexico, in Colorado, and Nevada. It has probably been formed by precipitation or replacement at comparatively low temperature.

Alteration products are bournonite, covellite, malachite, azurite, and oxidized antimony or arsenic minerals. Chalcopyrite often forms a crust enveloping the mother crystal of tetrahedrite, as at Liskeard, Cornwall. Tetrahedrite is an important ore of copper and silver.

STEPHANITE

Stephanite. — Ag_5SbS_3 ; Sulphantimonide of silver; $Ag = 68.5$, $Sb = 15.2$, $S = 16.3$, Orthorhombic; Type, Didigonal Polar; $\tilde{a} : \tilde{b} : \tilde{c} = .6291 : 1 : .6851$, $100 \wedge 110 = 32^\circ 10'$, $001 \wedge 101 = 47^\circ 26'$, $001 \wedge 011 = 34^\circ 25'$, $111 \wedge 110 = 37^\circ 51'$; Common forms, c (001), b (010), m (110), d (011), P (111); Twinning plane m quite common, others as a and b less so; Cleavage, b and d imperfect; Brittle, fracture uneven; $H. = 2-2.5$; $G. = 6.2-6.5$; Color and streak, iron-black; Luster, metallic; Opaque.

B.B. — On coal fuses easily with spirting, yielding a white coat of antimony trioxide, which may become red with oxidized silver. In O. F. yields an odor of sulphur dioxide. Reduced with soda yields a malleable button of silver.

General Description. — Crystals are usually tabular parallel to the base, or short stout prisms, at times elongated parallel to the brachyaxis. Twins with m as the composition face are often

repeated, yielding a pseudo-hexagonal symmetry. The polar nature of the crystals is shown by the diagonal striations on the prism faces; also granular or massive.



FIG. 406. — Stephanite. Freiberg, Saxony.

Fine crystals are obtained at Freiberg, Saxony, and in the Ophir mine, Nevada.

It is an important ore of silver and is found at all the noted silver localities of Europe, as in the Harz; Pribram, Bohemia; Kremnitz, Hungary; Kongsberg, Norway. In the United States it is the principal ore of silver in the noted Comstock lode in Nevada; also occurs at other points in Nevada and Idaho.

Polybasite, $9 \text{Ag}_2\text{S}, \text{Sb}_2\text{S}_3$, and Polyargyrite, $12 \text{Ag}_2\text{S}, \text{Sb}_2\text{S}_3$, are two sulphantimonides in the same series as stephanite, but higher in their silver content. The former usually contains some copper and has a good basal cleavage. The latter is isometric, crystallizes in cubo-octahedrons with a cubic cleavage.

ENARGITE

Enargite. — $3 \text{Cu}_3\text{S}, \text{As}_2\text{S}_5$; Sulpharsenate of copper; $\text{Cu} = 48.3$, $\text{As} = 19.1$, $\text{S} = 32.6$; Orthorhombic; Type, Didigonal Equatorial; $\tilde{a} : \tilde{b} : \tilde{c} = .8711 : 1 : .8248$; $100 \wedge 110 = 41^\circ 3'$; $001 \wedge 101 = 43^\circ 26'$; $001 \wedge 011 = 39^\circ 31'$; Forms, a (100), b (010), c (001), m (110), d (011); Twinning plane, x (320); Cleavage, m perfect, a and b distinct; Brittle, fracture uneven; $H. = 3$; $G. = 4.4$; Color and streak, grayish to iron-black; Luster, metallic; Opaque.

B.B. — Fuses easily in R. F. on coal and yields an arsenic odor. In the O. F. a sulphur dioxide odor. Roasted and reduced with soda yields malleable copper buttons. It may also contain antimony, zinc, or iron.

General Description. — Crystals are small, prismatic, and striated lengthwise; it usually occurs massive or disseminated. Not a common mineral, but at Butte, Montana, it is an important copper ore. Found also in several localities in Colorado, Utah, and in the Brewster gold mine, South Carolina.

CHAPTER VII

THE HALOID COMPOUNDS

HALITE

Halite. — Common salt; NaCl, Sodium chloride; Na = 39.4, Cl = 60.6; Isometric; Type, Ditesseral Central; Common forms, a (100), o (111); Cleavage, cubic perfect; Twins rare; Brittle, fracture conchoidal; H. = 2.5; G. = 2.1–2.6; Color, white, gray, blue, yellowish, or red; Streak, white; Luster, vitreous; Transparent to translucent; $n = 1.542$.

B.B. — Fuses at two (815°), often with decrepitation, and colors the flame intense yellow (Na). With S. Ph. bead saturated with copper oxide yields an azure blue flame (Cl). Dissolves in water easily and has a salty taste.

General Description. — Crystals are cubes, while other forms in combination are rare. When crystallized from solution containing caustic soda it separates in octahedrons, or in combinations of the cube and octahedron, according to the alkalinity of the solution. Natural crystals showing the cube and octahedron are rare. Twins are not known, except in some cases thin lamellæ have been noted which have probably been formed by pressure. Pure salt is white; the yellow and reddish colors are caused by such impurities as oxide of iron or clay. Calcium and magnesium sulphates and chlorides are often present, and these chlorides cause the deliquescence of many specimens of rock salt. The beautiful blue of some specimens from Stassfurt has been attributed to the presence of the subchloride of sodium or to small amounts of metallic sodium, as the blue color may be produced by exposing crystals to the vapors of sodium, also to the cathode ray, or to the radiations of radium.

Both halite and sylvite are diathermous and allow the non-luminous heat rays to pass with very little absorption.

Salt deposits are found in the sediments of all ages; those of New York are Upper Silurian, while those of Michigan are Carboniferous. They have been formed and deposited from solution, the

mother brines having become saturated by the evaporation of an enclosed arm of the sea. In some cases the supply of salt has been added to by a periodical breaking in of the sea, or by the waves washing over the inclosing bar; through these additions of salt, carried in by each fresh supply of water which in turn is evaporated, salt beds of enormous thickness have been made possible. Those at Spereberg, Germany, reach a thickness of 4000 feet, while the average thickness of the New York beds is 75 feet, and those of Michigan are in places 400 feet thick. Such beds of salt are in course of formation at the present time, under practically the above conditions, in some of the bays of the eastern shore of the Caspian Sea. Other deposits may form by the simple concentration of an inland sea, as the Salton Sea deposits of California. Both the Great Salt Lake and the Dead Sea are highly concentrated brines. The water of the Dead Sea contains 22.86 per cent. salt, while the average sea water contains but 3.5 per cent. Such lakes are nothing more than large evaporating dishes which deposit their salts in more or less definite order when concentration has reached saturation (see anhydrite), as the salt deposits of Stassfurt, Germany. When such deposits of salt are protected from the solvent action of percolating ground waters by an impervious stratum of clay, they have been preserved through the ages; however, many salt springs exist which derive their salt from such embedded deposits. All natural waters contain from one to ten parts of salt in a million in solution. The origin of the sodium contained in all these natural solutions and enormous deposits of salt have in large part resulted from the decomposition of feldspars; but the source of such quantities of chlorine is more difficult of explanation, since few primary minerals, as soldalite and apatite, contain chlorine, and they only in small amounts. The two states, Michigan and New York, produce three quarters of the thirty million barrels of salt used annually in the United States, while fourteen states contribute to the remaining quarter.

SYLVITE

Sylvite. — KCl ; Potassium chloride; $\text{K} = 52.4$, $\text{Cl} = 47.6$; Isometric; Type, Tesseral Holoaxial; Common forms, $c(100)$, $o(111)$; Twins rare; Cleavage, cubic perfect; Brittle, fracture uneven; $H. = 2$; $G. = 1.97$; Color, white, yellow, reddish, or blue; Streak, white; Luster, vitreous; Transparent to translucent; $n = 1.490$.

B.B. — Fuses at two (790°) and colors the flame violet (K). If much sodium is present, the blue glass should be used. With S. Ph. bead saturated with copper oxide yields an azure blue flame (Cl). Dissolves easily in water, yielding a saline taste.

General Description. — Crystals are usually small cubes and less often in combination with the octahedron; other forms are rare. The variation in color of specimens is due to impurities, as in the



FIG. 407. — Sylvite from Stassfurt, Prussia.

case of halite, as pure potassium chloride is white. Its holoaxial symmetry is clearly shown by the asymmetrical position of the square etch figures in relation to the edges and diagonals of the cube faces.

Sylvite is more soluble than halite, and is therefore deposited at a later stage in the concentration of complex salt solutions, or, in the sequence of the deposit, sylvite will lie above the stratum of halite and will be mixed with the more soluble magnesium compounds, from which at times sylvite may be formed as a secondary mineral.

All rock salt contains potassium chloride in small amounts, but the most noted deposit of potassium salts is that of Stassfurt in Prussia; smaller deposits of the same general nature are also found in Austria. It is from these European localities that the

commercial supply of the potassium salts of the world is at present obtained; for this reason they are most important, as potassium is one of the few elements required by all soils to produce good crops, and must be imported by all nations, as a fertilizer, to add to the soil when the original supply of potassium has been exhausted. It is also used in the production of niter (KNO_3) from Chili saltpeter, which is the oxidizing agent in gun and blasting powder.

CERARGYRITE

Cerargyrite. — Horn silver; Silver chloride, AgCl , $\text{Ag} = 75.3$, $\text{Cl} = 24.7$; Isometric; Type, Ditesseral Central; Forms, *a* (100), *d* (110), *o* (111); Twinning plane *o*; Cleavage, none; Highly sectile; *H.* = 1–1.5; *G.* = 5.55; Color, white gray to brown; Darkens on exposure to light; Luster, resinous to adamantine; Transparent to opaque; *n* = 2.61.

B.B. — On coal fuses easily, yielding globules of metallic silver. In the S. Ph. bead saturated with copper oxide yields an azure blue flame (*Cl*). Insoluble in acids, but soluble in ammonia.

General description. — Crystals are rare, but cubic in habit; it occurs more often massive, disseminated, or in crusts and dendritic.

The best specimens have been obtained from Peru, though good crystals are found in the Poor Man's lode in Idaho. Cerargyrite is an important ore of silver at the Comstock lode, Nevada; Leadville, Colorado, and Cobalt, Ontario. It is common in veins, associated with galena, native silver, barite, calcite, and quartz, especially in the superficial portions, where it is formed as a secondary mineral. Soluble silver sulphate is formed by the oxidation of sulphides, arsenides, or antimonides, and is then precipitated by contact with chlorides or by the intermixing with other solutions containing chlorides.

Cerargyrite has been produced artificially by the slow diffusion, through a diaphragm of asbestos, of solutions of sulphate and chloride of silver.

Bromyrite, AgBr , iodyrite, AgI , and embolite, $\text{Ag}(\text{ClBr})$, are very similar to cerargyrite, both in appearance and association. Iodyrite is interesting as an example of dihexagonal polar symmetry. They are all valuable ores of silver.

FLUORITE

Fluorite. — Calcium fluoride, CaF_2 ; Ca = 51.1, F = 48.9; Isometric; Type, Ditesseral*Central; Common forms, *c*(100), *o*(111), *d*(110), *e*(210), *t*(421); Twinning plane 111, interpenetrating; Cleavage, octahedral perfect; Brittle, fracture conchoidal to splintery; H. = 4; G. = 3.01–3.25; Color, white, various shades of yellow, green, blue, brown, and red; Streak, white; Luster, vitreous; Transparent to nearly opaque; $n = 1.434$.

B.B. — Fuses at 1387°C . to an enamel, yielding a reddish flame (Ca). The ignited fragment reacts alkaline with turmeric paper. With potassium bisulphate in the closed tube shows fluorine.

General description. — Crystals are beautifully developed and very common, usually cubic in habit: simple octahedrons are less



FIG. 408. — Fluorite and Calcite from Weardale, England.

common, but occur at Chamonix and St. Gothard, Switzerland; at Spitzenberg, and in Colorado. They are usually pink or rose-colored, with drusy faces, caused by repeated growths of small cubes.

Combinations of the cube, octahedron, and rhombic dodecahedron occur at St. Gothard, Switzerland; at Redruth in Cornwall, England; while cubes with the corners modified by the hexoctahedron (421) occur at Alston Moor and Weardale, England.

Fluorite presents a good example of a perfect octahedral cleavage; with care, perfect octahedral cleavage pieces may be split out, but

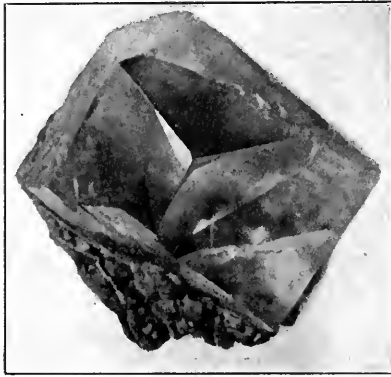

FIG. 409.—Fluorite Twins, showing the Hexoctahedron. Weardale, England.

as there are four cleavage directions the ultimate particles are tetrahedrons. In color, fluorite is the most variable of minerals; commonly it is white, yellow, purple, or green. The green specimens, termed chlorophane, and occurring at Trumbull, Conn., yield phosphorescent light when heated. The phosphorescence is, however, not confined to the green varieties. The various colors have been attributed to organic matter,

as many specimens, on heating, lose their color, and particularly if heated in oil. Transparent white specimens are very valuable, as, owing to the low index of refraction of fluorite, it is used in the construction of physical apparatus. Some colored crystals exhibit a slight birefringency caused by laminae parallel to the cube or octahedral faces; colorless specimens do not show this phenomenon.

Fluorite occurs more often as a vein mineral associated with sulphides or sulphates, as galena, sphalerite, and barite, and as a gangue in many metalliferous deposits. It is also associated with the deposits of cassiterite, for the formation of which, as a pneumatolytic agent, it is in large part responsible. Veins containing fluorite may be contained in both acid and basic igneous rocks as well as in the schists and sedimentary formations; it is of common occurrence lining the cavities of limestones, where it has been deposited from solution.

Less frequently it is found as a primary mineral in granites, syenites, and quartz porphyry; in which occurrences the escape of the volatile fluorides must have been prevented by the superimposed formations, as determined in the syenites of Norway. Fluor-

ite has also been produced by the condensation of vapors or by the interaction of volatile fluorides with other minerals, as in the lavas of Vesuvius.

Crystalline specimens of great beauty are obtained in Cornwall and Cumberland, England; at St. Gothard, Switzerland; at Amity and Brewster, and in St. Lawrence County, New York; and at Castle Dome, Arizona. Fluorite is mined in large quantities along the Ohio River in Illinois and Kentucky, where there are large deposits, filling veins in limestone, associated with galena, sphalerite, chalcopyrite, and pyrite. They were probably formed by precipitation or replacement of the calcium carbonate. Both in Virginia and Colorado fluorite is produced commercially, but as a by-product resulting from the mining of lead, zinc, or silver ores.

In the United States 60,000 tons are used annually, mostly as a flux in the metallurgical industries. By its use a very fluid slag, melting at a low temperature, is formed, at the same time lowering the sulphur and phosphorus content of the resulting iron or steel. It is used in minor quantities in the production of hydrofluoric acid, in enameling works, in glazes and opalescent glass. The famous Blue John mine of Derbyshire, England, produces a banded purple spar used for vases and other ornaments.

CRYOLITE

Cryolite. — Sodium aluminium fluoride; Na_3AlF_6 ; $\text{Na} = 32.8$, $\text{Al} = 12.8$, $\text{F} = 54.4$; Monoclinic; Type, Digonal Equatorial; $\bar{a} : \bar{b} : \bar{c} = .9663 : 1 : 1.3882$; $\beta = 89^\circ 49' = 001_{\wedge} 100$; $100_{\wedge} 110 = .44^\circ 1'$; $001_{\wedge} 101 = 55^\circ 2'$; $001_{\wedge} 011 = 54^\circ 14'$; Common forms, **a** (100), **c** (001), **m** (110), **d** (101), **r** (011); Twinning plane 010; Cleavage, **c** quite perfect, **m** less so; Brittle, fracture uneven; $H. = 2.5$; $G. = 2.95-3$; Color, white, reddish, brown to nearly black; Streak, white; Luster, vitreous to greasy, Transparent to opaque; $n = 1.36$; Optically (+). Axial plane perpendicular to 010; $\text{Bx}_{\wedge} \text{a}$ normal to 001 = $44^\circ 5'$; $2\text{E} = 59^\circ 24'$.

B.B. — Fuses easily to a white enamel, which becomes blue with cobalt solution (Al), yields a yellow flame, and the ignited fragment reacts alkaline with turmeric paper. Fused with potassium bisulphate in the closed tube shows fluorine.

General description. — Crystals are rare and exist only in the cracks of the massive mineral; as its name indicates, the massive

mineral when wet resembles ice in appearance. Crystals are cubelike in shape, with the corners and edges modified, while the massive mineral shows striations due to polysynthetic twinning.

There is but one large deposit of cryolite in the world, that of

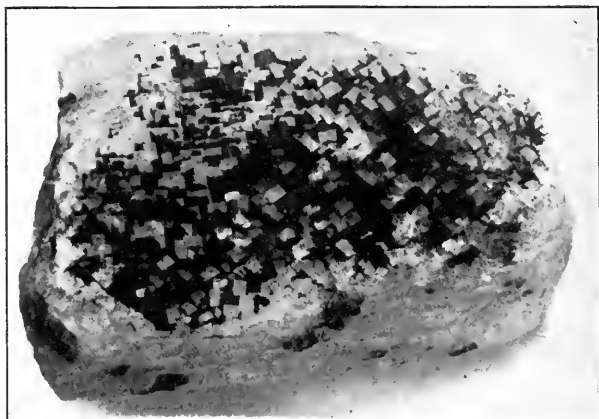

FIG. 410. — Cryolite Crystals from Ivigtut, Greenland.

Ivigtut, West Greenland. This deposit is from 500 to 1000 feet thick, occurring as a residual secretion in the granite; associated and contained in the cryolite are siderite, sphalerite, chalcopyrite, galena, and other rare minerals, such as columbite, wolframite, molybdenite, and cassiterite.

At Miask in the Urals and at the base of Pike's Peak in Colorado other deposits occur, but these are small and of no commercial importance. The product of the Greenland mine, some six or seven thousand tons, is used in the manufacture of glass, porcelain, and enamel ware. Cryolite forms the basis of the fused bath used as a solvent for the oxide of aluminium in the Hall electrolytic process for the reduction of the metal aluminium.

Associated with cryolite, as a secondary product formed by the substitution of calcium for some of the sodium, is pachnolite $(\text{Na, Ca})_3\text{AlF}_6, \text{H}_2\text{O}$.

ATACAMITE

Atacamite. — $\text{CuCl}_2, 3\text{Cu}(\text{OH})_2$; Basic chloride of copper; $\text{Cu} = 14.9, \text{Cl} = 16.6, \text{H}_2\text{O} = 12.7$; Orthorhombic; Type, Didigonal Equatorial; $\text{a} : \text{b} : \text{c} = .6612 : 1 : .7515$; $100 \wedge 110 = 33^\circ 28'$; $001 \wedge 101 = 48^\circ 49'$; $001 \wedge 011 = 36^\circ 58'$; Common forms,

b (010), **c** (001), **m** (110), **e** (011), **p** (111), **d** (110); Twinning plane 110; Cleavage, **b** perfect, 101 imperfect; Brittle, fracture conchoidal; H. = 3-3.5; G. = 3.75-3.77; Color, various shades of green; Streak, apple-green; Luster vitreous; Transparent to translucent; Optically (-); Plane of the optic axes parallel to 100; **Bx_a** parallel to **ä**.

B.B. — Fuses on coal, yielding an azure-blue flame, and in R. F. yields malleable copper buttons. In the closed tube blackens and yields water. Easily soluble in acids.

General description. — Crystals are slender prisms striated lengthwise and usually terminated by the unit pyramid and brachydome; more often massive, fibrous, or granular. First discovered as a sand associated with the copper ores in the province of Atacama, Chili. Occurs in dry regions associated with other copper minerals in Tarapaea, Bolivia; Wallaroo, Australia; and at Jerome, Arizona; but only in Chili does it occur in quantities sufficient to constitute an important copper ore.

CARNALLITE

Carnallite. — Potassium and magnesium chlorides; $\text{KCl} \cdot \text{MgCl}_2 \cdot 6\text{H}_2\text{O}$; K = 14.1, Mg = 8.7, Cl = 38.3, H_2O = 39.0; Orthorhombic; Type, Didigonal Equatorial; $\check{a} : \check{b} : \check{c} = .5935 : 1 : .6906$; $100 \wedge 110 = 30^\circ 41'$, $001 \wedge 101 = 49^\circ 19'$, $001 \wedge 011 = 34^\circ 37'$, $001 \wedge 111 = 53^\circ 32'$; Common forms, **c** (001), **m** (110), **p** (111); Cleavage, none; Fracture conchoidal, brittle; H. = 1; G. = 1.60; Color, white or reddish; Streak, white; Luster, greasy; Transparent to translucent; Deliquescent; Has a bitter taste; Optically (+); Plane of the optic axes parallel to **ä**; $2E = 115$ l.

B.B. — Easily fusible, yielding a violet flame (K). With S. Ph. bead saturated with copper oxide an azure-blue flame (Cl). After ignition on coal leaves a residue which becomes flesh-colored when treated with cobalt solution. Easily soluble in water, the solution having a bitter taste.

General description. — Usually massive, deposited in layers interbedded with salt and kieserite ($\text{MgSO}_4 \cdot \text{H}_2\text{O}$), and associated with sylvite and kainite, both of which may be derived from the carnallite, as percolating waters containing magnesium sulphate

dissolve the carnallite; on recrystallization the salts separate as sylvite and kainite.

The carnallite beds are at the top of the Stassfurt deposits and represent the last products of deposition from the brines. Here it is mined in large quantities, and together with kainite is the principal source of the quantities of potassium used as fertilizers.

CHAPTER VIII

OXIDES, INCLUDING THE ALUMINITES, FERRITES, CHROMITES

OXIDES OF THE RO TYPE

WATER

Water. — Ice; Snow; Frost; H_2O ; H = 11.1, O = 88.9; Hexagonal; Type, Dihexagonal Alternating; $d = 1.4026$; $0001 \wedge 10\bar{1}1 = 58^\circ 18'$; Common forms, *c* (0001), *m* (10 $\bar{1}$ 0), *r* (1012); H. = 1.5; G. = .9167; Luster, vitreous; Transparent; Color, white when pure, but blue in large masses; $\omega = 1.3090$; $\epsilon = 1.3133$; Optically (+).

B.B. — Fuses at 0° , volatilizes entirely, leaving no coat and yielding no odor.

General description. — Crystals with individual faces rare; sometimes they occur on hailstones. Usually complex stellate aggregates produced by twinning; occurs during low temperature as frost, snow, and sheets of ice covering lakes and streams. In the high latitudes it forms the permanent polar ice cap. In Alaska sheets of geological ice occur interbedded with sedimentary deposits. Glaciers are streams of ice moving from the perpetual snow-covered mountain ranges to lower altitudes.

CUPRITE

Cuprite. — Red oxide of copper; Cuprous oxide, Cu_2O ; Cu = 88.8; O = 11.2; Isometric; Type, Tesseral Holoaxial; Common forms, *a* (001); *o* (111); *d* (110); Cleavage, octahedral imperfect; Brittle, fracture conchoidal; H. = 3.5–4; G. = 5.85–6.15; Luster, adamantine to earthy; Color, cochineal-red to nearly black; Streak, shades of red or brown; Transparent on thin edges to opaque; $n = 2.849$.

B.B. — Fuses and in R. F. yields malleable copper, and an emerald green flame. With the fluxes shows copper. Easily soluble in acids.

General description.— Crystals are octahedrons, rhombic dodecahedrons, and cubes, or combinations of these three forms. Other forms occur, but are rare. The pentagonal didodecahedron



FIG. 411.— Crystalline Cuprite. Cornwall, England.

(986) has been described as occurring on crystals from Cornwall, England. It is never twinned. Occurs in compact, granular, massive, and also earthy forms. Tile ore is an impure cuprite mixed with limonite and hematite.

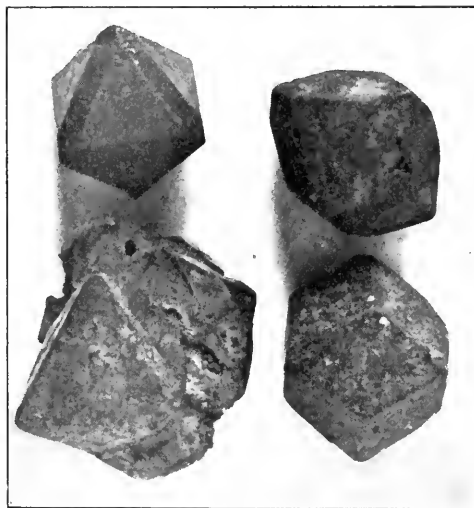

FIG. 412.— Cuprite Coated with Malachite.
Chessy, France.

Cuprite is found in connection with all copper deposits, as a secondary oxidation product in the surface or upper levels of the workings. It is formed as the result of oxidation of the sulphur of sulphides, reducing some of the copper to the metallic state, which is in turn oxidized to cuprite. Quite

often masses of cuprite are found which still inclose a core of metallic copper that has as yet not been oxidized to cuprite.

Cuprite may oxidize to CuO , the black oxide of copper, tenorite, or by the action of percolating waters containing carbon dioxide be oxidized and transformed to the carbonates, either malachite or azurite, as is illustrated by the pseudomorphs of malachite after cuprite of Chessy, France, some of which still contain a central nucleus of cuprite.

It occurs in good crystals at Bisbee, Arizona; in the Lake Superior region; and along the border of the trap of the Atlantic coast, as at Somerville, New Jersey; at New Haven, Connecticut. Elongated, capillary, distorted cubes occur at Morenci, Arizona, in plushlike mats, forming the variety known as chalcotrichite. Noted European localities are Cornwall, England, where beautiful crystals with complicated and rare forms are found; also Chessy, France, in individual crystals, combinations of the octahedrons and the rhombic dodecahedron.

Cuprite is an important ore of copper.

ZINCITE

Zincite. — Oxide of zinc, ZnO ; $\text{Zn} = 80.3$, $\text{O} = 19.7$; Hexagonal; Type, Dihexagonal Polar; $\epsilon = 1.621$; $0001 \wedge 10\bar{1}1 = 61^\circ 54'$; Forms, p (1011), m (1010), c (0001); Cleavage, basal and prismatic; Brittle, fracture subconchoidal; $H. = 4-4.5$; $G. = 5.43$; Color, deep red to orange; Streak, orange; Luster, adamantine; Transparent to nearly opaque; Optically (+).

B.B. — Infusible. In R. F. with soda and borax on coal yields a zinc coat. Easily soluble in hot acids without effervescing. Generally shows manganese with the fluxes.

General Description. — Crystals are very rare, usually simple hemipyramids, as both the base and prism are rare faces on natural crystals. Crystals of zincite appearing as flue or slag products are much more complex than the natural crystals.

Pure oxide of zinc is white, but



FIG. 413. — Zincite Crystal from Franklin, New Jersey.

the natural oxide, occurring as it does with other manganese minerals, is colored by that element.

The only deposit of zincite in the world of any importance is at Franklin and Sterling, Sussex County, New Jersey, where it forms an important zinc ore; otherwise a very rare mineral. Here it is intimately mixed with franklinite, willemite, and embedded in calcite. Cleavable masses are common, which may also have a lamellar structure. The crystals occur in isolated side stringers, where the conditions of formation have differed from that of the general body of the deposit, as these crystals are associated with such rare minerals as leucophaenite, pyrochroite and gageite.

TENORITE

Tenorite. — Melaconite; Black oxide of copper, CuO ; $\text{Cu} = 79.8$, $\text{O} = 20.2$; Triclinic; $\bar{a} : \bar{b} : \bar{c} = 1.4902 : 1 : 1.3604$; $\beta = 80^\circ 28'$; $100 \wedge 110 = 55^\circ 46'$, $001 \wedge 101 = 38^\circ 2'$, $001 \wedge 011 = 53^\circ 18'$; Forms, $a(100)$, $c(001)$, $p(111)$; Twinning plane, 001 ; Cleavage, basal easy; Brittle, fracture conchoidal; $H. = 3-4$; $G. = 5.85$; Color, iron-gray to black; Streak, black; Opaque; Metallic.

B.B. — Fuses and in the R. F. on coal is reduced to malleable copper. Other reactions as in cuprite.

General Description. — Crystals are rare; small plates hexagonal in outline occur in the lavas of Vesuvius. Mostly occurs in the black massive form, melaconite, or granular, earthy, and disseminated. It is a common mineral occurring usually in small quantities in the upper oxidation zone of most all copper deposits, though not as common as the red oxide, cuprite. It is the ultimate product formed in the oxidation of other copper minerals, as the sulphides, native copper, and cuprite.

Tenorite fuses at 1050°C. , when it loses oxygen and forms cuprite.

Other anhydrous protoxides of the formula of $\text{R}''\text{O}$, in nature, are very rare and occur in localities in which there has been a peculiar combination of physical and chemical conditions which has favored their formation.

Periclase, MgO , is an isometric mineral found in cubo-octahedrons in the lavas of Vesuvius and also at Nordmark, Sweden.

Manganosite, MnO , occurring at Langban, Sweden, and bun-

senite, NiO, occurring at Johaungeoigenstadt, Saxony, are both isometric minerals crystallizing in small cubes.

Massicot, PbO, is a massive yellow mineral found in several localities in Chihuahua, Mexico.

OXIDES OF THE R_2O_3 TYPE

CORUNDUM

Corundum. — Sesquioxide of aluminium, Al_2O_3 ; Al = 52.9, O = 47.1; Hexagonal; Type, Dihexagonal Alternating; $c = 1.363$; $0001_A 10\bar{1}1 = 57^\circ 34'$; $r_A r' = 93^\circ 56'$; Common forms, $a (11\bar{2}0)$, $r (10\bar{1}1)$, $c (0001)$, $v (4483)$, $n (22\bar{4}3)$; Twinning plane r , polysynthetic; Cleavage, parting parallel to r and c at times perfect; H. = 9; G. = 3.95–4.1; Color, gray, red, blue, green, white, or nearly black; Streak, white; Luster, adamantine; Transparent to opaque; $\omega = 1.768$; $\epsilon = 1.76$; $\omega - \epsilon = .008$; Optically (—).

B.B. — Infusible, fusing point 1880° ; the very fine powder heated on coal in O. F., moistened with cobalt solution, and again heated becomes blue. Insoluble in acids, but dissolves slowly both in borax and the S. Ph. beads.



FIG. 414. — Corundum Crystals from Montana.

General description. — Crystals when large are coarse, rough prisms, swelling in the middle and drawn in at the ends or barrel-shaped, terminated with the base; such large crystals are opaque

and colored brown or flesh-colored from the iron content, Fe_2O_3 being isomorphous with Al_2O_3 . Clear corundum is variable in color and runs through the entire list of colored precious stones. When it is wished to convey the idea that the gem in question is corundum, the term "oriental" is prefixed, as "oriental topaz," "oriental amethyst," or "oriental emerald," etc. The true ruby is corundum; and when of that dark "pigeon blood" red, so much sought after and of the right transparency, it is the most expensive of gems, even surpassing the diamond of the first water in value.

The ruby is colored with small quantities of chromium, while the sapphire and other colors are due to cobalt, titanium, or iron.

Its physical properties, together with its wide range of colors, render the transparent varieties of corundum an ideal gem stone. It is the third hardest substance known, being surpassed only by the diamond and silicon carbide, a product of the electric furnace.

Corundum is a primary mineral of such igneous rocks as granites, syenites, rhyolites, and rocks rich in alumina.

In thin sections it appears transparent and nearly colorless, with or without crystalline outline, and there are no characteristic inclusions. Relief is strong, and the interference colors are of the first order yellow or gray.

In addition to being a primary mineral of igneous rocks, it is also a characteristic mineral of the belt of metamorphism, and is there associated with tourmaline, spinels, cyanites, garnets; while in its decomposition by weathering it forms a whole series of aluminous minerals, as gibbsite, diasporite, margarite, muscovite, etc.

Occurrence.—Most of the gem material is of Eastern origin; the best rubies are found in the gravels of Irrawaddy River, near Mandalay, Burma, and in the crystallized limestone on its eastern bank; the crystals are tabular in habit and associated with spinels and garnets. Those recovered from the river gravels are rounded and water-worn, but owing to their excessive hardness some still retain their crystalline faces. In Ceylon the gemstones are also recovered mostly from the gravels of the Ratnapura and Rakwena districts. In the United States sapphires are found in the gravel bars of the upper Missouri River in Montana, and stones of gem value are mined in the Judith River valley, Montana. These are contained in a dyke cutting through a crystalline limestone. The dyke having weathered faster than the limestone may be traced by a depression across the country for five miles, and many sapphires have been taken from the piles of dirt at the entrance to the gopher

holes. The decomposed dyke furnished much easier digging for these little animals than the hard crystalline limestone adjacent. Corundum is also found all along the Blue Ridge in Virginia, North and South Carolinas, and Georgia. Very fine blue specimens have been obtained at Sparta, New Jersey, and at various points in Sussex County. Most of the "adamantine spar" used in the United States is mined in Renfrew County, Ontario, where it occurs in a coarse pink syenite. Emery is a compact or granular variety of corundum which is mixed with a large proportion of oxides of iron. It is mined at Chester, Massachusetts, and at Peekskill, New York. In the latter locality it is associated with hercynite, magnetite, and garnet, and occurs as a segregation product from the norite of the Courtland series. Abroad emery is mined in Asia Minor, Turkey, and Greece; 60 per cent. of this product is exported to the United States.

Corundum and emery are commercially used as an abrasive, especially in emery paper for polishing and cleaning metals; in wheels for sharpening steel tools, and in the cutting of glassware, though artificial corundum made from bauxite by heating it to a high temperature in an electric furnace is fast replacing the natural mineral.

Artificial crystallized Al_2O_3 may be produced by fusing equal parts of Al_2O_3 and lead oxide, and allowing the fusion to cool slowly, when tabular crystals of corundum separate; if a little oxide of cobalt is added, they will be sapphire-blue; if a little potassium dichromate is added they will be ruby-red. The so-called reconstructed rubies are formed in the oxyhydrogen flame; by rotating a small crystal rapidly in the flame with the temperature near the fusing point, it is then built up with fine particles of natural ruby, the color being regulated by the amount of chromium present. These artificial stones in their physical properties differ in no way from the natural ruby, and they puzzle even the expert to recognize them. They have however peculiar circular markings or pores, due to the rotation in the flame while in a semifused condition, which are a material aid in their identification.

HEMATITE

Hematite. — Red oxide of iron, Fe_2O_3 ; Fe = 70, O = 30; Hexagonal; Type, Dihexagonal Alternating; $c = 1.3656$; $0001 \wedge 10\bar{1}1 = 57^\circ 37'$; $r \wedge r' = 94^\circ$; Common forms, $c(0001)$, $r(1011)$, $e(01\bar{1}1)$, $u(10\bar{1}4)$; $n(22\bar{4}3)$; $m(10\bar{1}0)$; Twinning plane r , both

interpenetrating and polysynthetic; Cleavage, none, parting caused by twinning; Brittle, fracture uneven; H. = 5.5-6.5; G. = 4.9-5.3, varies with the structure; Luster, metallic, splendid in crystals, dull in massive form; Color, dark iron-gray, red, reddish brown, to black; Streak, cherry-red; Opaque except in thin scales when blood-red by transmitted light; $\epsilon = 2.94$; $\omega = 3.22$; $\omega - \epsilon = 0.28$; Optically (-).

B.B. — Nearly infusible (1350°). In R. F. on coal blackens and becomes magnetic, with the fluxes shows iron. Soluble in HCl at least in fine powder on heating, when impure there will be a considerable residue of quartz.

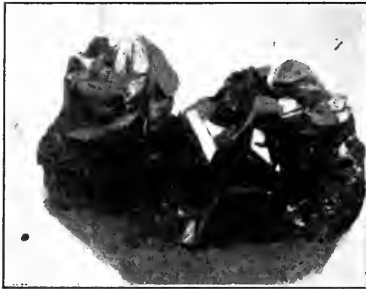

FIG. 415.—Hematite Crystals from Elba.

General Description. — When crystalline, usually in tabular crystals with a splendid luster or iridescent, combinations of *m*, *r*, *e*, *n*, and *c*, with striations on the base; a large number of other forms have been described. ∇ Micaceous hematite is formed by thin scales in parallel

position. All highly lustrous crystalline hematites are known as specular iron ore. Another peculiar complex aggregate in which the individual crystals are arranged radially around the center like the petals of a rose, "eisenrosen," occurs at St. Gothard, Fig. 416.

Amorphous hematite occurs massive, fibrous, radiated, botryoidal, concretionary, or apparently soft and unctuous, "clay iron-stone," which soils the fingers; all such varieties are red, brown, or even slightly yellowish in color, as they grade into limonite; but all true hematites yield a cherry-red streak.

Hematite is connected with igneous rocks in which it occurs as a primary constituent, as black scales, easily mistaken for magnetite.

Many feldspar phenocrysts, especially orthoclase, which seems to have a predisposition to collect these fine hematite scales

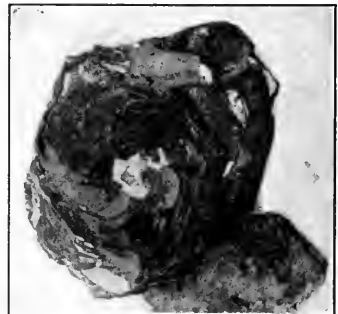

FIG. 416.—Eisenrosen. St. Gothard, Switzerland.

as inclusions, are colored red by them. Indeed most of the red sedimentary rocks are colored with hematite, as jaspers, sandstones, shales, and clays.

The most important deposits of hematite are associated with sedimentary rocks, where the layers of hematite are interbedded with chert, jasper, shales, and sandstones. These deposits have been derived from the chemical precipitation of Fe_2O_3 resulting from the oxidation of ferrous carbonate in solution. These precipitates gather in layers at the bottom of drainage basins, their physical condition depending upon future metamorphism to hematite. Such are the fossil and oölitic hematites connected with the Clinton formation, extending from New York to Alabama.

In the Lake Superior region the oxidation of silicates, pyrite, and carbonates has filled an important rôle in the formation and concentration of enormous deposits, which have yielded millions of tons of ore, but like the Clinton ores they are connected with sedimentary formations. In the oxidation and replacement processes hematite may form pseudomorphs after pyrite, calcite, siderite, magnetite, quartz, and fossils, especially shells. A variety of Fe_2O_3 , martite, occurring in large octahedrons at Twin Peaks, Mallard County, Utah, is possibly magnetite oxidized to hematite.

Eighty per cent. of all iron ore mined in the United States is hematite, most of which is taken from the Lake Superior region, where it is mined in large open quarries, as it lies near the surface. The principal localities are Marquette, Menominee, and Gogebie, Wisconsin; Vermilion and Mesaba districts of Minnesota; and the Northern Peninsula of Michigan. In the East hematite is mined at various points along the Clinton formation. Large deposits also occur at Iron Mountain, Missouri; in Wyoming; while Nova Scotia and Newfoundland supply the Canadian industries. The best crystalline specimens are obtained from the Isle of Elba; from Cumberland, England, where it is associated with quartz and dolomite; at St. Gothard, Switzerland, in rosettes and in flat tabular scales associated with rutile crystals. Large rosettes five or six inches across are obtained from Brazil.

Artificial. — Micaceous hematite crystals may be formed by heating a concentrated solution of ferrous sulphate with copper sulphate in a sealed tube for 10 hours at a temperature of 210° .

Fe_2O_3 when fused loses oxygen and on cooling forms magnetite. On fusing ferric oxide and borax and dissolving the melt in hot dilute HCl crystals of hematite will be left.

Hematite is also formed, as in the lavas of Vesuvius, by decomposing the vapors of ferric chloride with steam.

Arsenic, antimony, and bismuth form anhydrous sesquioxides which are found as minerals, but only in small quantities and restricted in distribution. Those of arsenic and antimony are isomorphous and dimorphic. Arsenolite, As_2O_3 , occurs at the Ophir mine, Nevada, and appears as white crusts on native arsenic. Senarmontite, Sb_2O_3 , is formed as a coating on stibnite. Both are isometric, crystallizing in octahedrons.

Claudetite, As_2O_3 , and valentinite, Sb_2O_3 , are both formed by oxidation of other minerals; the former is monoclinic, the latter orthorhombic.

Bismite, Bi_2O_3 , is orthorhombic in artificial crystals, in nature it is not crystalline. It occurs at Schneeberg, Bohemia, as a white to yellowish powder.

ILMENITE

Ilmenite. — Menaccanite; Titanic iron ore; Ferrous metatitanate, FeTiO_3 ; $\text{FeO} = 47.3$, $\text{TiO}_2 = 52.7$; Hexagonal; Type, Hexagonal Alternating, $c = 1.3845$; $10\bar{1}1 \wedge \bar{1}101 = 94^\circ 29'$; $0001 \wedge 10\bar{1}4 = 21^\circ 47'$; $0001 \wedge 01\bar{1}2 = 38^\circ 38'$; $0001 \wedge 22\bar{4}3 = 61^\circ 33'$; Usual forms, c (0001), a ($11\bar{2}0$), m ($10\bar{1}0$), r ($10\bar{1}1$), e ($01\bar{1}2$), u ($10\bar{1}4$), n ($22\bar{4}3$); Twinning plane, 0001 or $10\bar{1}1$, usually lamellar; Cleavage, none; Brittle, fracture conchoidal; $H. = 5-6$; $G. = 4.5-5$; Color, black to brownish; Streak, black to brownish; Submetallic; Opaque; At times slightly magnetic.

B.B. — Fuses on the thin edges in a strong R. F., and becomes magnetic; otherwise infusible. Well powdered and fused with soda, the fusion boiled in strong HCl and reduced with powdered tin, yields a violet colored solution (titanium). Reacts for iron with the fluxes.

General Description. — Crystals are tabular parallel to the base, usually combinations of the prism a , the rhombohedron r , and the base or combinations of the base and the rhombohedrons r , s , and n . When tabular the base is often marked with striations, forming triangular areas in outline, as the striations are parallel to the rhombohedral faces. The tabular crystals are often grouped in rosette aggregates, or "eisenrosen" as is hematite. Bright and well-formed crystals are not common. It is usually massive, compact, or in disseminated, rounded grains, or as sand.

Ilmenite has been grouped with the sesquioxides, as Ti_2O_3 is isomorphous with Fe_2O_3 , but there is no doubt but that ilmenite is a ferrous metatitanate and is out of place here as placed by Dana's classification. Magnesium and manganese are both isomorphous with ilmenite, and pyrophane is the manganous metatitanate, $MnTiO_3$.

Ilmenite occurs associated with magnetite and under the same conditions, as a primary constituent of igneous rocks; as such it is one of the first minerals to separate from the magma. It is more abundant in the basic rocks, as the diorites, diabases, and basalts. It also occurs in schists, gneisses, metamorphic rocks, argillites, and slates.

In rock sections it is opaque and appears brownish by reflected light. When in crystalline outline it is elongated, but occurs more often as rounded grains and irregular masses, not to be distinguished from magnetite or chromite but by chemical tests. Ilmenite is often altered, resulting in a clear or translucent boundary, or area surrounding the opaque masses, composed of a highly doubly refracting substance termed leucoxene, formed by the decomposition of the ilmenite, and which has been identified as perovskite ($CaTiO_3$), as titanite, and again as anatase. Ilmenite occurs in large masses at Bay St. Paul, Quebec, also in Orange Co., New York, associated with serpentine, spinel, rutile, and chondrodite; at Litchfield, Connecticut; at Chester and South Royalston, Massachusetts. The largest crystals of ilmenite, some of which weigh sixteen pounds or more, have been found in a diorite at Kragerö, Norway. As an accessory in igneous rocks ilmenite is very widely distributed.

Ilmenite finds but little use in commerce; it is used as linings in puddling furnaces, but owing to the difficulty of handling it in the blast furnaces it is not used as an iron ore, though at the present time titanium steel is being tried for rails with encouraging results. Artificially ilmenite has been formed by heating a mixture of metallic iron, ferric oxide, and amorphous titanite oxide in a sealed tube to 270° - 300° C.

OXIDES OF THE RO_2 TYPE

CASSITERITE

Cassiterite. — Stream tin; Tin binoxide, SnO_2 ; Sn = 78.6, O = 21.4; Tetragonal; Type, Ditetragonal Equatorial; $\epsilon = .6723$; $001_{\lambda} 101 = 33^{\circ} 54'$; $110_{\lambda} 111 = 46^{\circ} 27'$; Common forms,

$s(111)$, $e(101)$, $m(110)$ $a(100)$. Twinning plane 101, both geniculate and cyclic; Cleavage, 110 imperfect; Brittle, fracture uneven; $H. = 6-7$; $G. = 6.8-7.1$; Luster, splendid adamantine; Color, various shades of brown, red, and gray to almost black; Streak, pale; $n = 1.997$.

B.B. — Infusible, reduced with soda and borax on coal yields malleable tin buttons. Insoluble in acids.

General description. — Crystals are short stout prisms with the prism faces striated parallel to the c axis, usually terminated with the two unit pyramids. Acicular crystals terminated by the pyramids (321) and (521) occur at Cornwall, England, also massive or

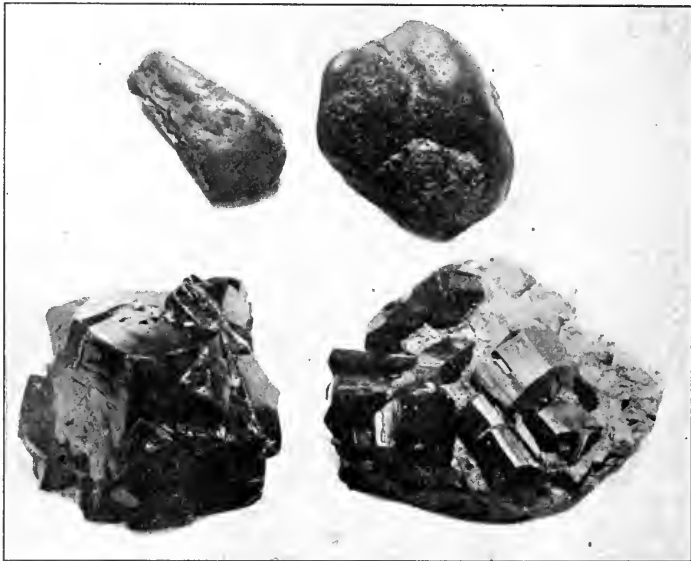

FIG. 417. — Cassiterite from Bohemia. The Upper Figures are Stream Tin from Mexico.

granular. While cassiterite is found as a granular or disseminated primary accessory mineral in some igneous rocks, it is more often connected with the cavities and pegmatitic veins in the region of granitic masses which have been intruded in sedimentary formations. Here its origin is the result of pneumatolytic agencies which have concentrated the tin on the border of the granitic mass, where it has been deposited in the veins, close at hand, of the disturbed area. In such veins it is associated with fluorite, tourma-

line, topaz, and other rarer minerals, as wolframite, scheelite, or uraninite, which have been concentrated by the same agents.

Owing to its high specific gravity and not being affected by weathering, cassiterite is left behind after most of the other minerals forming the rock mass have been decomposed and carried away; it is thus mechanically concentrated in the bottom of streams as rolled, rounded, and water-worn pebbles (stream tin). It is from these alluvial deposits that a large amount of the tin of commerce is recovered.

Little cassiterite is produced or mined in the United States; small deposits are found in Lincoln County, North Carolina; at Harney's Peak, South Dakota; near El Paso, Texas; and in the Seward Peninsula, Alaska. The world's supply is derived from the Malay Peninsula, Bolivia, Australia, and Cornwall, England.

RUTILE

Rutile. — Dioxide of titanium, TiO_2 ; $Ti = 60$, $O = 40$; Tetragonal; Type, Ditetragonal Equatorial; $c = .644$; $001 \wedge 101 = 32^\circ 47'$; Common forms, *s* (111), *e* (101), *m* (110), *a* (100), Twinning as in cassiterite; Cleavage, 110 and 001 good; $H. =$

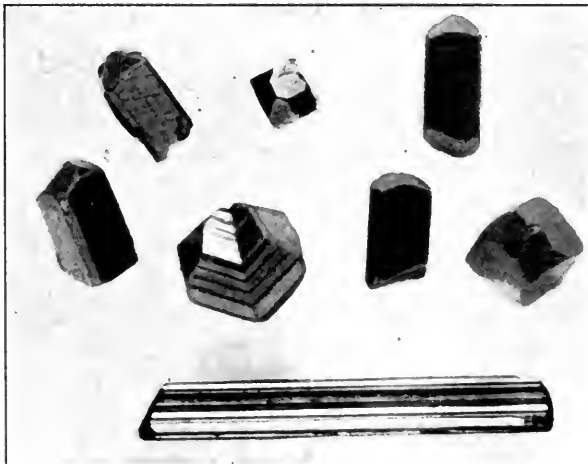

FIG. 418. — Rutile Crystals from Lynchburg, Virginia.

6-6.5; $G. = 4.18-4.25$; Brittle, fracture uneven; Color, shades of brown to nearly black; Streak, pale brown or reddish; Luster, adamantine, metallic in appearance; Translucent to opaque; $\omega = 2.615$; $\epsilon - \omega = .287$; Optically (+).

B.B. — Infusible. In the S. Ph. bead beside tin on coal yields a violet color when cold; the bead powdered and dissolved in concentrated HCl, then reduced with powdered tin, yields a violet solution. Insoluble in acids.

General Description. — Rutile occurs in all varieties of rocks, igneous, metamorphic, and sedimentary, either as short stout, or elongated and acicular prisms, with striations on the prism zone parallel to the \hat{c} axis; very often these long, hairlike crystals are



FIG. 419. — Acicular Crystals of Rutile included in Quartz. Japan.

found penetrating clear quartz, as at St. Gothard, Switzerland, when the specimens are polished and cut as ornaments. At this same locality small prismatic rutile crystals are found placed in parallel position on hexagonal plates of hematite. At Tavetsch, Switzerland, reticulated, platelike masses of elongated crystals, interlocking at the twinning angle of $65^{\circ} 35'$, occur and are known as sagenite.

Rutile in the United States has been mined in Virginia, where it is found near Arring-

ton in a pegmatite; at Nelson it is associated, in dykes, with apatite; at Lynchburg beautifully formed crystals with a steel-like luster, both simple and twinned, are common, as also in Alexander County, North Carolina, and at Graves's Mountain, Georgia.

As a secondary mineral rutile is derived from octahedrite and brookite, forming pseudomorphs after the latter, as at Magnet

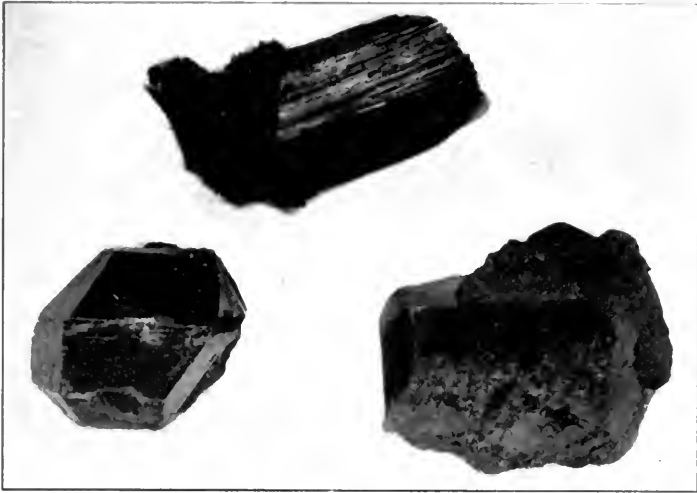

FIG. 420.—Rutile Crystals from Graves's Mountain, Georgia. The Upper Twins are from the Tyrol.

Cove, Arkansas. These three minerals are all dioxides of titanium, in different phases, and are quite often associated; rutile has the highest specific gravity and is the stable form at high temperatures. Octahedrite is also of tetragonal symmetry, while brookite is orthorhombic. Rutile may also be formed in the alteration of ilmenite and titanite, which process is reversed in the alteration of rutile.

Chemically rutile generally contains iron, to which the red or brown color is due; the iron content is considerable in some cases and massive rutile may grade gradually into ilmenite.

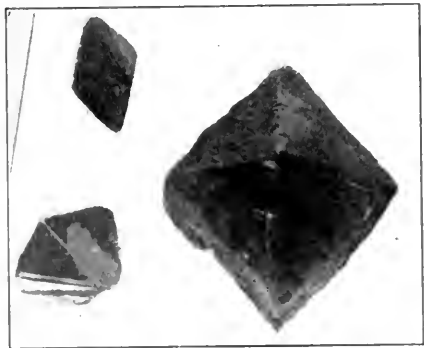

FIG. 421.—Brookite from Magnet Cove, Arkansas.

Commercially rutile is the source of titanium salts, which are used as a yellow coloring agent in porcelain and to obtain the ivory-

like color in artificial teeth. Titanium trichloride is replacing stannous chloride as a mordant in cloth printing. Ferro-titanium is used to produce a hard steel, with a high transverse and tensile strength; this more recent use may in the near future increase the demand for titanium minerals.

PYROLUSITE

Pyrolusite. — Dioxide of manganese, MnO_2 ; Mn = 63.2, O = 36.8; Amorphous but often in pseudomorphs; H. = 2–2.5, soils paper; G. = 4.82; Color and streak, black; Luster, metallic to dull, opaque.

B.B. — Infusible, shows manganese with the fluxes. In the closed tube yields little or no water. Dissolves in HCl with the liberation of chlorine.

General Description. — Massive, compact, fibrous, stalactitic, or dendritic. Oxides of manganese are usually associated with iron ores, having been formed in many cases by the interaction of the same agents. Pyrolusite is formed from hydrated oxides of manganese by loss of water. It has been thought that pyrolusite may be orthorhombic in symmetry, but it is probable that such crystals are pseudomorphs derived from manganite by the expulsion of its water.

Oxides of manganese are concentrated at many localities either by replacement or by precipitation from solutions resulting from the decomposition of silicates or carbonates containing manganese. Such deposits are associated with limestone and sedimentary formations, or form irregular pockets and nodules in clays. Such deposits extend all along the Appalachian and Piedmont regions, where they are mined commercially in the Blue Ridge Mountains of Virginia, and at Cartersville, Georgia. Pyrolusite is also mined at Batesville, Arkansas; and Livermore, California. Cabinet specimens are obtained at Salisbury, Connecticut, and Stockbridge, Massachusetts.

QUARTZ

Quartz. — Silicon dioxide, SiO_2 ; Si = 46.7, O = 53.3; Hexagonal; Type, Trigonal Holoaxial; $c = 1.100$; Common forms, $m(10\bar{1}0)$, $r(10\bar{1}1)$, $z(01\bar{1}1)$, $x(51\bar{6}1)$, $s(11\bar{2}1)$; $0111 \wedge 0110 = 38^\circ 13'$; $10\bar{1}0 \wedge 51\bar{6}1 = 12^\circ 1'$; $10\bar{1}0 \wedge 1\bar{1}01 = 38^\circ 18'$ Cleavage, r perfect but difficult; Brittle, fracture conchoidal; H. = 7; G. =

2.65; Color, when pure, colorless or white, when impure, all shades; Luster, vitreous, splendid to dull or greasy; Streak, white, or in colored specimens very pale; Transparent to opaque; $\epsilon = 1.5532$; $\omega = 1.5441$; $\epsilon - \omega = .0091$; Optically (+); Rotary polarization in thick sections.

B.B. — Infusible (1600°); yields little or no water in the closed tube; when finely ground and fused with two volumes of soda on the platinum wire yields a clear bead when cold. Insoluble in acids except hydrofluoric.

General description. — Crystals are very common and well developed, usually elongated parallel to the c axis, combinations of the plus and minus rhombohedrons and the unit prism. The prism faces are often striated horizontally, which serves to identify the prism faces on distorted specimens. The trigonal pyramid s



FIG. 422. — Quartz Var. Rock Crystal. Hot Springs, Arkansas.

and the trapezohedron x are common in certain localities, but are, like the large number of other forms that have been described, rare except for the few favored localities. When the two rhombohedrons are equally developed, the crystals have the appearance of being terminated by a hexagonal pyramid, but this is not pos-

sible in the type in which quartz crystallizes. When the rhombohedrons are unequally developed, the plus rhombohedron r is usually the larger and has a high luster, in fact is more perfect than the minus rhombohedron z , which may be dull, and faces occurring in the same zone with it and the prism face beneath it are also apt to be dull, while the faces appearing under r will be bright.

Since the right and left trigonal trapezohedrons are rare forms or restricted to noted localities, it is not always possible to determine

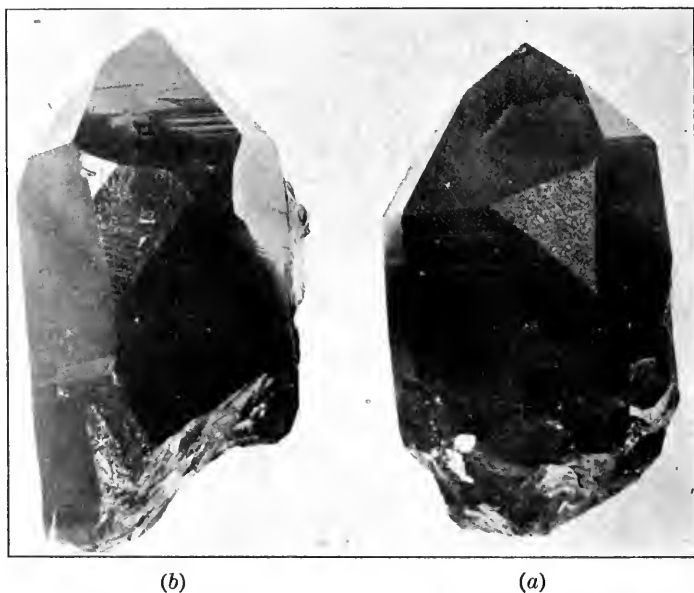

FIG. 423. — Right- (a) and Left- (b) handed Smoky Quartz Crystals from St. Gothard, Switzerland.

whether any given specimen is a right- or left-handed crystal; but when the trigonal trapezohedron is present, the crystal is a right-handed one when the face appears in the upper right-hand corner of the prism face, or just below the right-hand corner of r , and left-handed when in a similar position in the left-hand corner.

The trigonal pyramid s is a member of the same zone as m , x , and z , and will appear between z and x ; striations on s parallel to the intersection of s and r are characteristic, and will determine the character of the crystal when x is absent. Holding the crystal in the usual position, when these striæ run from northeast to southwest, as directions are considered on a map, the crystal is right-

handed; if from northwest to southeast the crystal is left-handed. Again if the edges of the zone $mxsz$ ascend to the right around the crystal, like a right-handed screw, the crystal is right-handed; if to the left, left-handed. Still a fourth method of distinguishing right and left crystals is by the corrosion figures which often appear on crystals as the result of some solvent, or are produced artificially by treatment with hydrofluoric acid; these figures are pointed at one end and broad at the other; those on the right are minor images of those on the left.

As the trapezohedral faces are a key to both the twinning of quartz and its right- or left-handedness, it should be remembered that four of these forms are possible. The positive forms occur the more often, and are situated below r , the



FIG. 424. — Quartz Twinned, composed of Right-hand Individuals. St. Gothard, Switzerland.

positive right under the right-hand corner, and the positive left directly under the left-hand corner. The left-handed forms hold the same relation to the rhombohedral faces z .

Twinning in quartz is very frequent, though it is not always to be recognized unless the trapezohedral faces are present.

1. Interpenetrating twins occur, where the twinning axis is normal to the prism edge. In such twins x will occur on adjacent prism faces, modifying the upper right-hand corner; they may not appear on all six prism faces, but if they do appear on any two adjacent faces it is sufficient to establish the twinned nature of the crystal. In all such twins the rhombohedral faces are complex in nature, portions which are bright are r and portions which may be dull are z ; these areas are quite irregular and separated by curved and jagged boundaries, plainly shown in the photographs. Whether the twin consists of two right- or two left-handed individuals may be determined from the relation of x to the bright patches of the rhom-

bohedral faces, as x will be under the bright areas in right- and under the dull areas in left-handed crystals.

2. Twins occur in which the face x modifies both upper or both lower corners of the prism face; these are twinned by reflection over a plane perpendicular to the prism face and parallel to the vertical axis. These are termed Brazilian twins and are often repeated, interpenetrating and quite irregular, but the twins are always formed by the union of right and left individuals. In some cases the plane of reflection may pass through opposite prism edges, when four x faces will lie adjacent to a single and alternate prism edge.

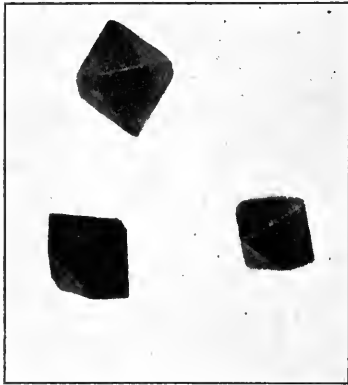

FIG. 425. — Quartz Crystals from near Rome, Italy.

3. Twins occur in which the twinning axis is perpendicular to the rhombohedral face $11\bar{2}2$; after a revolution of 180° around this axis the vertical crystallographical axes of the two individuals will lie at $84^\circ 33'$. This type of twins is usually flattened parallel to the prism face and they are known as the Japanese twins, as the most beautiful specimens are obtained from that country.

Quartz is the most common of all minerals. It is distributed universally and occurs under the most varied conditions. It is one of the essential minerals of granite, mica schist, and gneiss, while quartzite and sandstones may be almost pure quartz. In rock magmas SiO_2 takes the part of an acid, and for this reason quartz is never found in the basic and dark-

colored igneous rocks, as quartz is formed only in those cases where there is an excess of SiO_2 over the basic oxides. It is usually near the last to crystallize or separate in the solidification of a rock

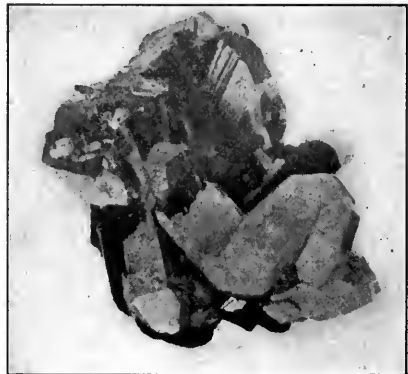

FIG. 426. — Quartz twinned on $11\bar{2}2$.
Alaska.

magma. It may therefore include within its mass all those minerals which have separated previous to it, as the oxides of iron, rutile, apatite, zircon, mica, amphibole, and pyroxene; and in some instances it forms a ground mass in which the individual crystals of other minerals are imbedded.

In the final solidification of acid igneous rocks, quartz usually preserves a balanced equilibrium with orthoclase, separating as a eutectic, which is well illustrated in the structure of the micropegmatites, where the crystals are so fine and intimately mixed as to be revealed only by the microscope.

In thin sections quartz is colorless and transparent. Its index of refraction is so near that of Canada balsam that there is scarcely any relief, and the quartz grains when free of inclusions have the appearance of holes in



FIG. 427. — Enlarged Micropegmatite between Crossed Nicols. The Light Areas are Quartz, the Dark Orthoclase.

the rock sections. In sections less than .04 mm. in thickness the interference is gray or yellow of the first order. It is often filled with small inclusions of liquids or gas.

As a secondary mineral quartz may be formed by the solvent action of percolating waters containing carbon dioxide, decomposing complex silicates by carrying out the bases in solution, forming carbonates of the bases and quartz. The SiO_2 may dissolve also, to be later deposited in veins, cracks, and cavities, either in the form of quartz or as hydrated silica (opal). Such quartz is associated with many ore deposits as the gangue mineral or vein filler; it has a peculiar greasy luster and splintery fracture and is often termed vein quartz.

The quartz grains of granites resist atmospheric weathering; and when changes and decomposition of the other minerals are in progress at the surface, these grains remain unchanged in the residue, forming the sands of the soil; or when washed clean and redeposited

by running water form the stratified sandstones in which silica deposited from solution may be the cementing agent.

Varieties. — Rock crystal is that clear, colorless, crystallized variety to which the sciences of mineralogy and crystallography owe so much. It has furnished convenient material to the scientist and physicist for experimentation and for apparatus since historic times, and it stands in its relation to crystallography as the frog does to the biological sciences. It has indeed furnished the name crystal, as the ancients believed it to be water which had been subjected to such a low temperature as to be no longer capable of returning to the liquid state. Nicolaus Steno in 1669 noted the similarity of the angles between crystal faces on quartz while cutting sections.

Beautiful clear crystals of quartz occur in the calcareous sandstone of Herkimer County, New York, known from their brightness as Herkimer County diamonds. These are in some cases chemically pure SiO_2 , others are colored dark with carbonaceous inclusions, while others have cavities containing liquids in which bubbles may be rolled back and forth like the bubble of a spirit level. Evidently all these crystals have, from the character of the inclusions, been formed from solution and at a low temperature. This variety of quartz is in all cases considered to have been formed at a temperature below that of 575°C ., for when quartz is heated to a temperature of 575°C ., it passes over to another phase, β -quartz, in which the physical properties are different from α -quartz, the phase stable below 575°C .

Large crystals and thick sections of quartz in passing this inversion temperature are shattered, crack and fall in pieces; β -quartz is hexagonal holoaxial, while α -quartz is trigonal holoaxial; and whenever the trigonal trapezohedral face x appears, that crystal must have been formed at a temperature below the inversion point and as α -quartz, since the trigonal trapezohedron is not a possible form in the hexagonal holoaxial type; also the occurrence of two rhombohedrons r and z unequal in development and luster would indicate that the crystal had separated as α -quartz, since these faces in the hexagonal holoaxial type should be similar in all respects. Quartz of granite micropegmatites and some macropegmatites has been formed at a temperature above 575° , as is shown by its fractured condition. Large clear crystals are found at the Hot Springs, Arkansas; these have been formed in several stages of growth as is indicated by the internal crystalline outlines known as "phantoms,"

caused at this locality by fine crystals of chlorite being deposited on the crystal at different periods of its growth. More complicated crystals are found in North Carolina, showing rare forms.

Quartz is quarried in Connecticut, Maryland, New York, Wisconsin, and North Carolina, for various purposes. When finely ground it is used as a filler in paints and scouring soaps. It is used in pottery and glass, and recently it has been fused and blown as glass, in chemical ware, such as evaporating dishes, flasks, crucibles, and ignition tubes, for the determination of carbon; here it has the advantage, due to its low coefficient of expansion, of not being liable to crack when submitted to sudden changes of temperature; even when at a bright red heat it may be plunged into cold water without the least danger of cracking. After fusion it has lost its crystalline structure and is amorphous silica, but on repeatedly heating and cooling, the molecules will rearrange themselves and become crystalline, and then the tubes are liable to shatter on passing the inversion temperature of β - to α -quartz.

Colored quartz. — Owing to small quantities of metallic oxides or organic matter as impurities quartz may appear in various colors. Some of the colored varieties have received special names, as citrine or yellow quartz, which is clear and transparent, in appearance very much like the topaz, and indeed when cut, polished, and mounted in jewelry is sold in the trade as topaz, or false topaz. The best examples of this variety are obtained from Brazil. Smoky quartz is a dark colored variety of crystalline quartz which owes its color to organic matter or carbon compounds. The evenly colored transparent specimens are polished and valued as a semiprecious stone. Disentis and St. Gothard, Switzerland, are noted localities. These crystals generally have the faces x and s well developed. In the United States, it occurs at Pike's Peak, Colorado; in Richmond County, New York; and very large crystals have been obtained at Paradise River, Nova Scotia.

Amethyst is a purple or bluish violet quartz which is colored with small amounts of manganese or possibly by organic matter. The color may vary greatly; in most specimens it is unevenly distributed through the crystal, and is usually concentrated at the apex. Dark, evenly colored crystals are much prized as a semiprecious stone. The best colored specimens are from Siberia, India, Uruguay, and Brazil. Pale varieties are widely distributed. In the United States amethysts of good color are found in Lincoln and Macon counties, North Carolina; Nelson County, Virginia; Rabun

County, Georgia; Thunder Bay, Lake Superior; also at Digby Neck, Nova Scotia.

Other varieties are cryptocrystalline or aggregates of radiated, parallel, or matted fine fibers; in all these the chemical properties



FIG. 428. — Onyx from Brazil.

are the same as crystalline quartz, but they are softer and of a little lower specific gravity.

Chalcedony is a translucent, concretionary form of SiO_2 , usually light in color, often stalactitic or botryoidal, occurring as crusts lining cavities, and in geodes, which often contain large cavities partly filled with water, which may be seen through the translucent wall on rolling the specimens back and forth. When very marked in color they have been given special names, as carnelian for the translucent red variety. Chrysoprase is light green, colored by the oxide of nickel.



FIG. 429. — Moss agate.

Bloodstone is chalcedony with small inclusions of red jasper. The banded varieties are agates, and when the bands are flat and

regular it is onyx. At times the impurities are dendritic and appear like pieces of moss inclosed within the specimen; these are moss agates. When dark in color and associated with limestones in nodules it forms flint. Lydian or touchstone is also a very dark, almost black, variety, used by the goldsmiths to test the purity of their gold alloys, by means of the color of the streak made by the metal in drawing it across the stone.

Jasper is an opaque variety of impure SiO_2 of a red, brown ocher, gray, green, or black color.

In addition there are pseudomorphs of SiO_2 after shells, wood (silicified wood), or bones; and various minerals, as carbonates and sulphates, may be replaced by SiO_2 from solution.

TRIDYMITE

Tridymite. — Silicon dioxide, SiO_2 ; Hexagonal, Hexagonal above 130°C ., below probably Orthorhombic; $c = 1.653$; 0001_A $10\bar{1}1 = 62^\circ 21'$; Common forms, $c(0001)$, $m(10\bar{1}0)$, $a(1120)$, $p(10\bar{1}1)$; Twinning plane $10\bar{1}6$ and 3034 ; Cleavage, $10\bar{1}0$ distinct; Brittle, fracture conchoidal; $H. = 7$; $G. = 2.28-2.33$; Colorless to white; Luster, vitreous; Streak, white; $\epsilon = 1.477$.

B.B. — Like quartz, but soluble in boiling alkaline carbonates. Fuses at 1625°C .

General Description. — Crystals are small hexagonal tablets, combinations of the base, prism, and pyramid, or aggregations of these small scaly crystals. At ordinary temperatures tridymite is pseudo-hexagonal; above 130° it becomes truly uniaxial, and below it shows low double refraction (.0018), is optically (+), and is probably orthorhombic in symmetry. It is not a common mineral, but found in acid volcanic rocks and lavas, as in the lavas of Vesuvius and Krakatau, Obsidian Cliff, Yellowstone Park, and in some meteorites. It was discovered at Pachuca, Mexico, where it occurs in aggregates of twins; in the cavities of an andesine rock. It has since been discovered in many localities connected especially with, and in cavities of, the more recent acid volcanic rocks.

Tridymite and quartz are polymers of SiO_2 . The transition temperature between the two is near 800°C ., quartz being the more stable phase below, and tridymite the more stable phase above that temperature. Artificially, tridymite has been formed both in solution and in dry fusion. When a silicate is dissolved in the salt

of phosphorus bead, the silica left behind as the silica skeleton is in the form of tridymite.

HYDRATED OXIDES

BRUCITE

Brucite. — Hydroxide of magnesium, $\text{Mg}(\text{OH})_2$; $\text{MgO} = 69$, $\text{H}_2\text{O} = 31$; Hexagonal; Type, Dihexagonal Alternating; $c = 1.208$; $r \wedge r' = 97^\circ 38'$; $0001 \wedge 10\bar{1}1 = 60^\circ 20'$; Common forms, c (0001), r ($10\bar{1}1$), p ($20\bar{2}1$); Cleavage, basal perfect, laminæ sectile; $H. = 2.5$; $G. = 2.4$; Color, white, greenish or bluish; Streak, white; Luster, waxy to pearly; Translucent to opaque; $\epsilon = 1.579$; $\omega = 1.559$; $\epsilon - \omega = .020$; Optically (+).

B.B. — Whitens and becomes opaque; when it contains Mn or Fe may change to gray on heating. After ignition reacts alkaline with turmeric paper; with cobalt solution becomes flesh-colored (Mg). Infusible; in the closed tube yields much water. Soluble in acids.

General description. — Crystals are rare; they occur as tabular combinations of the base and rhombohedrons at Texas, Pennsylvania. Brucite is usually foliated or fibrous, variety nemalite.

Brucite is a secondary mineral formed in the zone of hydration from magnesium silicates and is nearly always associated with serpentine, both being derived from a common origin. By the action of carbon dioxide brucite forms hydromagnesite, $3 \text{MgCO}_2 \cdot \text{Mg}(\text{OH})_2 \cdot 3\text{H}_2\text{O}$.

It occurs at the Tilly Foster mine, Brewster, New York; Richmond and Westchester Counties, New York. At Bergen Hill, New Jersey, fibrous. Artificial crystals are produced by precipitating MgCl_2 with KOH and heating to 200° under pressure; on cooling, brucite separates. It has also been noted as a constituent of boiler scale.

Pyrochroite, $\text{Mn}(\text{OH})_2$, is isomorphous with brucite; found in simple rhombohedrons and in combinations with the base and scale-nohedrons at Franklin Furnace, New Jersey. Crystals are nearly transparent and light in color when first brought to the surface, but soon darken and become opaque on exposure. Found also in several localities in Sweden.

IRON HYDROXIDES

Limonite. — Hydroxide of iron; Brown hematite; Bog iron ore; $2\text{Fe}_2\text{O}_3 \cdot 3\text{H}_2\text{O}$; $\text{Fe}_2\text{O}_3 = 85.5$, $\text{H}_2\text{O} = 14.5$; Amorphous; Brittle; H. = 5-5.5; G. = 3.6-4; Color, dark brown to ocher-yellow; Luster, submetallic to dull; Streak, ocher-yellow.

B.B. — Like hematite, but yields water in the closed tube.

General description. — All the varieties of hydrated oxides of iron are colloids with no constant chemical composition; their water content varies with their state of dehydration, with the one exception of göthite, $\text{FeO}(\text{OH})$, which crystallizes in the orthorhombic system. They are all secondary minerals produced by oxidation and hydration in the belt of weathering; where deposited from solution in caves and cavities they form stalactites, botryoidal masses, and crusts, with a fibrous or radiated structure which at times have a very characteristic surface as if varnished, or as if having been fused, and in some specimens beautifully iridescent.



FIG. 430. — Limonite Stalactite. Ore Hill, Connecticut.

In the oxidation of sulphides, as pyrite or marcasite, ferrous sulphate is formed and carried in solution, while a hydrated oxide of iron remains behind, as the gossans, capping many of the sulphide ore deposits of the West. Many crystals of pyrite have been replaced in this way by pseudomorphs of limonite and turgite ($2\text{Fe}_2\text{O}_3 \cdot 2\text{H}_2\text{O}$). Large specimens of this nature are obtained from Australia, and small crystals, though perfect in outline, are found near Lancaster, Pennsylvania. Beautiful pseudomorphs of limonite after marcasite occur in a clay in Richland County, Wisconsin. Many pyrite crystals in Virginia and Maryland have a coat of varying thickness of limonite enclosing the still unoxidized sulphide.

The waters of swamps and some springs carry ferrous salts in solution, either connected with organic acids or as carbonate or sulphate. When exposed to the air these salts oxidize and the iron



FIG. 431. — Limonite Pseudomorph after Marcasite from Richland County, Wisconsin.

is separated as ferric hydrate, which may be noted many times as an iridescent oil-like film on the surface of stagnant water of swamps. When the surface is agitated, the film of heavy oxides sinks, and constantly accumulating on the bottom they form the lake and swamp deposits of "bog iron ore." It is not necessary to add that such ore is usually impure, from the nature of its formation; it is mixed with sand and organic matter and often contains considerable phosphorus and sulphur. Numerous iron springs are so charged with iron in solution that their banks and beds become coated with a bright yellow gelatinous deposit of ferric hydrate. Limonite is found in clays and as a residual deposit of ferruginous limestones, the calcium carbonate having been removed in solution, while the ferrous carbonate was oxidized and remained in place and concentrated as the chemical reactions continued. Such limonites associated with limestones are found along the Blue Ridge in western Virginia and in Tennessee, where they are mined

as an iron ore. The hydrated ores of iron mined in the United States are eight or ten per cent. of the total product. They are mined in Alabama, Virginia, Tennessee, Georgia, and Connecticut; at Salisbury in the latter state beautiful stalactitic specimens are obtained. In the West it is used as a flux in the smelters. Large quantities of limonite are used as a cheap metallic paint and as a pigment in the coloring of mortars, as ocher, umber, and sienna; after the water is driven out by heat they form burnt umber or burnt sienna.

HYDRATED OXIDES OF ALUMINIUM

DIASPORE

Diaspore. — $\text{AlO}(\text{OH})$; $\text{Al}_2\text{O}_3 = 85.0$, $\text{H}_2\text{O} = 15.0$; Orthorhombic; Type, Didigonal Equatorial; $\tilde{a} : \tilde{b} : \tilde{c} = .9372 : 1 : .6038$; $100_{\tilde{a}} 110 = 43^\circ 9'$; $001_{\tilde{a}} 101 = 32^\circ 48'$; $001_{\tilde{a}} 011 = 31^\circ 7' 35''$; Common forms, **c** (001); **b** (010), **m** (110), **h** (210); Cleavage, brachypinacoidal eminent, **h** less so; Brittle, fracture conchoidal; H. = 6.5-7; G. = 3.3-3.5; Color, white, yellowish, gray to brown; Streak, white; Luster, brilliant to pearly on cleavage faces; $\alpha = .702$; $\gamma = 1.750$; $\alpha - \gamma = .048$; Optically (+); Axial plane = 010; $\text{Bx}_{\tilde{a}} = \tilde{a}$.

B.B. — Most specimens decrepitate and yield water in the closed tube; after ignition with cobalt solution becomes blue. Infusible; after ignition, soluble in H_2SO_4 , otherwise not attacked by acids.

General Description. — When crystalline it is tabular or in scales and flakes; also acicular with striations parallel to the \tilde{c} axis. More often massive, encrusted or stalactitic. Generally associated with corundum as in Macon County, North Carolina, and especially with the impure form emery, as at Chester, Massachusetts, and in Chester County, Pennsylvania. It is also found with chloritic schists and in dolomites. As a decomposition product it may be formed by the weathering of corundum, nephelite and sodalite, or the reverse of this is also true, and diaspore by dehydration forms corundum.

GIBBSITE

Gibbsite. — Hydrargillite; Hydroxide of aluminium, $\text{Al}(\text{OH})_3$; $\text{Al}_2\text{O}_3 = 65.4$, $\text{H}_2\text{O} = 34.6$; Monoclinic; Type, Equatorial;

$\bar{a} : \bar{b} : \bar{c} = 1.7089 : 1 : 1.9184$; $\beta = 85^\circ 29' = 100 \wedge 110$; $001 \wedge \bar{1}01 = 50^\circ 50'$; $001 \wedge 011 = 62^\circ 24'$; Common forms, c (001), a (100), m (110); Cleavage, basal, micaceous laminae tough and wills how percussion figures as in mica; $H. = 2.5-3.5$; $G. = 2.28-2.42$; Color, white, green, gray, or reddish; Streak, white; $\alpha = 1.5347$ $\gamma = 1.5577$; $\gamma - \alpha = .023$; Optically (+); Bx_a in the angle β , $20^\circ 57'$ from \bar{c} ; Axial plane = 010.

B.B. — Like diaspore, except it is soluble in H_2SO_4 and in potassa solution.

General description. — Hydrargillite, the crystalline form, is rare; it occurs in tabular habit, parallel to the base and with a hexagonal outline; more often botryoidal, stalactitic, or in crusts, as in Dutchess and Orange counties, New York, and at Richmond, Massachusetts.

Gibbsite is not a common mineral and occurs under the same conditions and associations as diaspore.

Artificial scaly crystals may be prepared by passing CO_2 through a hot alkaline solution of aluminium hydroxide.

BAUXITE

Bauxite. — $Al_2O_3 \cdot 2H_2O$; $Al_2O_3 = 73.9$, $H_2O = 26.1$, but variable; Amorphous; $H. = 1-3$; $G. = 2.4-2.55$; Color, white, gray, when iron is present yellowish or red; Streak, white; Luster, dull to earthy; Opaque.

B.B. — Infusible, yields water in the closed tube, and is little attacked by acids; otherwise like diaspore.

General description. — In large deposits it is claylike, or oölitic and porous; usually brown or red from iron. It was originally described from Baux, France, where it was found in disseminated grains in a compact limestone. Its origin has been attributed to the direct weathering of basalt-like rocks; this seems to be certainly so in some German localities; from rhyolites; or again, as in case of the Arkansas bauxites, connected with the decomposition of syenites. Other bauxites have been formed as a chemical precipitate, when hot ascending waters have brought solutions of alumina to the surface, where they have been precipitated by calcium or other carbonates.

The bauxite deposits of the United States are found in Alabama, Georgia, and Arkansas, where it is mined in large quantities.

Commercially it is the source of all the metallic aluminium, which is reduced, after purification, electrolytically from its solution in fused cryolite. While bauxite has been described as a separate species, it may be only a mixture of the other two hydroxides of aluminium, diaspore and gibbsite, as its composition is variable. By metamorphism bauxite forms corundum; in fact corundum wheels are now made from a product obtained by heating bauxite to a high temperature.

MANGANESE HYDROXIDES

MANGANITE

Manganite. — $\text{MnO}(\text{OH})$; $\text{Mn}_2\text{O}_3 = 89.7$, $\text{H}_2\text{O} = 10.3$; Orthorhombic; Type, Didigonal Equatorial; $\tilde{a} : \tilde{b} : \tilde{c} = .844 : 1 : .545$; $100_{\wedge} 110 = 40^{\circ} 10'$; $001_{\wedge} 101 = 32^{\circ} 50'$; Common forms, c (001),

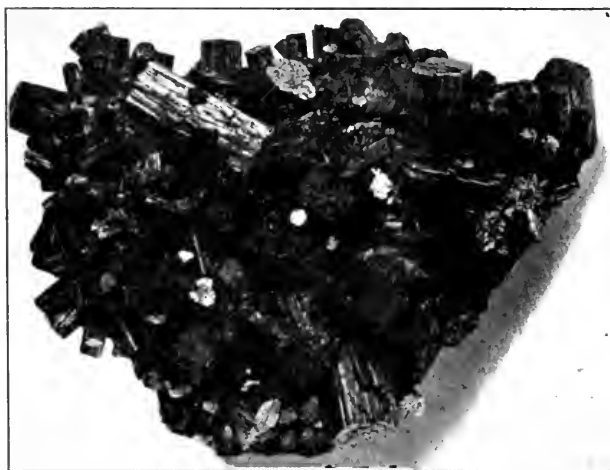

FIG. 432. — Manganite from the Harz, Germany.

m (110), l (120), d (210); Twinning plane e (011) common; Cleavage, brachypinacoidal perfect, m imperfect; Brittle, fracture uneven; $H. = 4$; $G. = 4.2 - 4.4$; Luster, submetallic though bright; Color, dark steel gray; Streak, brown to black; Opaque.

B.B. — Infusible. In the closed tube yields much water. Dissolves in HCl , liberating chlorine; with the fluxes reacts for manganese.

General description. — Nearly always crystalline; in habit elongated parallel to the vertical axis with deep longitudinal stria-

tions giving the crystals the appearance of parallel growths or complex aggregates; also acicular, radiated, fan-shaped or in the form of dendrites.

Beautiful specimens are obtained in the Harz, Germany, where it is associated with calcite. Manganite is a secondary mineral formed much in the same way as limonite. Manganese is dissolved out of the igneous or sedimentary rocks by percolating waters and is carried in solution to be precipitated either as carbonate or oxide. It is therefore a vein mineral, where it is associated with calcite, quartz, and iron oxides, or it is found in nodules in clays and sedimentary deposits. By dehydration manganite passes into pyrolusite, which often retains the form of manganite. Small equidimensional crystals of manganite are found at Salisbury, Connecticut, associated with the limonite. It also occurs in the Lake Superior region; in Douglas County, Colorado. For use see pyrolusite.

Pyrochroite, $Mn(OH)_2$, is isomorphous with brucite, see page 362.

PSILOMELANE

Psilomelane is an amorphous mixture of various hydrated oxides of manganese and therefore varies greatly in its composition. It generally contains barium oxide. One variety, asbolite, contains cobalt, and another, lampadite, contains copper.

Amorphous, botryoidal, stalactitic, reniform, or in crusts; Color, black to steel-gray; Luster, submetallic to dull and earthy; Streak, brown to black; Opaque; H. = 5.6, earthy varieties are soft, soiling the fingers; G. = 3.7-4.7.

B.B. — Like manganite, but usually contains barium or other elements isomorphous with barium.

General description. — Psilomelane is associated with limonite and they are both formed by the same agencies and under the same conditions, so much so that all limonites will yield a qualitative test for manganese, and in some cases the amount of manganese may be considerable.

Wad is the soft earthy form; it is also known as bog manganese ore, as it is deposited from solution in many streams and marshes. The pebbles in many streams are covered with a soft, velvety coating of amorphous hydroxide of manganese. These oxides also occur as nodules on the floor of the ocean, where the oxides have accumulated around some object, as a bone or shark tooth, as a

nucleus. Nodular manganese oxides occur in clays and other sedimentary formations.

Psilomelane occurs at Brandon, Vermont, and at several points



FIG. 433. — Psilomelane from Langenberg, Saxony.

in Arkansas. Asbolite is found at Silver Bluff, South Carolina.

Lampadite, as well as wad, occurs in the Copper Queen mine, Arizona.

OPAL

Opal. — $\text{SiO}_2 \cdot n(\text{H}_2\text{O})$; Amorphous; The amount of water varies according to the dehydration; Brittle, fracture conchoidal; $H. = 5.5-6.5$; $G. = 1.9-2.3$; Color, all colors; Luster, vitreous to resinous; Streak, white; Transparent to nearly opaque; $n = 1.436-1.450$. In thin sections isotropic and colorless, filling small cracks and as crusts in amygdaloidal cavities.

B.B. — Like quartz, but yields water in the closed tube; in some specimens this may be small in amount. Soluble in boiling alkali solution.

General description. — Opal is gelatinous or colloidal silica, deposited from solutions. Perecolating waters decompose many silicates, especially the orthosilicates, the silica of which may be again deposited either as quartz or opal. If there are alkalis present in the solution, quartz is usually the mineral formed; if alkalis are absent, opal is the form in which the silica is deposited. Thus opal is connected as a secondary component of lavas and sedi-

mentary rocks, especially in the cavities of argillites and limestones; also as a deposit around hot springs and geysers. In the filling of cavities from which other minerals or fossils have been removed by solution, opal appears as pseudomorphs, especially after wood, as wood opal, where even the structure of the wood fiber has been replaced, step by step, and so faithfully that in some cases the species of wood may be microscopically identified.

Hyalite is a clear, colorless, botryoidal opal, having the appearance of frogs' eggs, from which it takes its name; it is a very dense opal, showing double refraction from internal stress. The best specimens are obtained at Waltseh, Bohemia.

Precious opal is a transparent to translucent variety yielding a play of colors or flashes of light, as of fire, which have been attributed to minute fractures formed as the silica lost water. The thin films of air in the cracks disperse the light, yielding the beau-

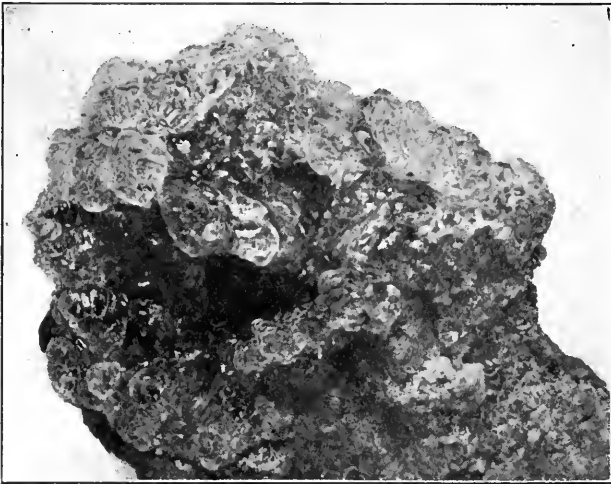

FIG. 434. — Opal Var. Hyalite from Waltseh, Bohemia.

tiful play of colors which is so much admired in the opal as a gem. The best gem opals were originally obtained in Hungary, where they were found filling cracks and small cavities in an andesite. More recently opals with a good play of color have been found in Queensland, Australia; and a fire opal of a honey-yellow color is found at Queretaro, Mexico, in a rhyolite; these opals are jelly-like and lack the fire of the Austrian or Australian specimens.

Geyselite is an opaque white, but very porous opal, deposited

by the waters of hot springs and geysers. Large quantities of geyserrite are being deposited by the geysers and hot springs of the Yellowstone Park, and in New Zealand and Iceland.

Tripolite, or infusorial earth, is an opal-like silica secreted by organisms, as the shells of diatoms. They may form beds of considerable extent; such deposits are found in Maryland, Virginia, Alabama, Missouri, and California.

Tripolite is used commercially as a wood filler; as an abrasive; as a filter stone; in scouring soap; as a polishing powder; as a non-conductor of heat for packing steam pipes and boilers; in the manufacture of dynamite, as a holder for the nitroglycerine; and in California as a building stone.

Artificially opal is formed by the drying of gelatinous silica.

SPINEL GROUP

The spinels form a small, well-defined group of isometric minerals, crystallizing in the ditesseral central type with an octahedral habit, or in combinations of the octahedron, rhombic dodecahedron, and the cube, while the cube with rare exceptions is a subordinate form. Chemically they are salts of the general acid $HR'''O_2$, in which R''' may be Al, Fe''' , Cr, Mn''' , or mixtures of these, and the H may be replaced by Mg, Fe'' , Zn, Mn'' , or Be; in case of the latter in combination with Al the mineral chrysoberyl is formed, the only mineral of the series which is not isometric, but orthorhombic. They are aluminites, ferrites, manganites, or chromites, and have usually been classified with the oxides. They may be primary constituents of the igneous rocks, in which, when they occur, they are among the first minerals to crystallize. They may also be formed as the results of thermal metamorphism or be derived from the decomposition of other minerals as precipitates.

Spinel, $MgAl_2O_4$.

Hereynite, $FeAl_2O_4$.

Gahnite, $ZnAl_2O_4$.

Magnetite, $FeFe_2O_4$.

Manganoferrite, $MgFe_2O_4$.

Franklinite $(Fe . Zn . Mn) (Fe, Mn)_2O_4$.

Jacobsite, $(Mn . Mg) (Fe . Mn)_2O_4$.

Chromite, $FeCr_2O_4$.

SPINEL

Spinel. — Magnesium metaluminite, $MgAl_2O_4$; $MgO = 28.2$, $Al_2O_3 = 71.8$; Crystal forms, o (111), d (110), other forms, (001),

(311), (322), (221), (332) rare; Twinning plane, 111; Cleavage, octahedral imperfect; Brittle, fracture conchoidal; Streak, white; H. = 8; G. = 3.5-4.1; Luster, vitreous; Color, gray, brown to black in opaque specimens, in transparent, red, blue, pink, green yellow; $n = 1.715$.

B.B. — The light-colored varieties may change color; infusible; insoluble in acids; in fine powder becomes blue with cobalt solution.

General description. — Crystals always well formed, of octahedral habit, in combination with the rhombic dodecahedron and cube; other forms are rare. Pure spinel is white or light in color, but as some of the magnesium is always replaced with other metals of the isomorphous group, the various colors are due to these and to impurities. In sections always pale in color, and owing to its high index of refraction the surface is rough, showing a high relief. Crystals are well formed with good outlines or in rounded grains, but always fresh and free from decomposition. Some crystals have the appearance of having been fused, with a glazed surface and rounded edges; this is a characteristic of all the species of the group.

Spinel may occur as a primary accessory mineral in igneous rocks, especially those rocks rich in magnesium or aluminium; often as picotite, a variety in which ferrous iron replaces the magnesium, and chromium some of the aluminium. Spinel is often connected with contact metamorphism and occurs in a granular limestone, from Sparta in northern New Jersey to Amity in New York; these are well-formed gray and brown crystals associated with serpentine.

In North Carolina it occurs with corundum, from which it may be formed as a decomposition product. It may also result from the alteration of olivine, garnets, or other minerals rich in magnesium or aluminium.

Ruby spinel, so called from its resemblance in color to the true ruby, and is nearly as hard, is used as a gem. The gem material is associated with corundums in the gem-bearing gravels of Ceylon and Burma; of the various colors the "flame-red" and blue are the most sought after. Ruby spinels occur also at Gold Bluff, California.

Artificial spinels may be formed by fusing the oxides or fluorides of magnesium and aluminium with boric acid; various colors may be produced by the addition of small amounts of iron and chromium oxides.

MAGNETITE

Magnetite. — A ferrous ferrite, FeFe_2O_4 ; $\text{Fe}_2\text{O}_3 = 69.0$, $\text{FeO}_2 = 31.0$; Isometric; Type, Ditesseral Central; Common forms, $o(111)$, $d(110)$, other rare forms, (001) , (311) , (531) , (310) ; Twinning parallel to 111; Cleavage, octahedral imperfect; Brittle, fracture uneven; $H. = 5.5-6.5$; $G. = 5.17-5.18$; Color, iron-black; Streak, black; Luster, metallic splendent or dull; Naturally magnetic.

B.B. — Fuses with difficulty (1225°C.), and in a strong O. F. changes to red (Fe_2O_3) and loses its magnetism. In fine powder is soluble in hot concentrated HCl ; but if it contains titanium or magnesium, it may dissolve with difficulty. Insoluble in HNO_3 .

General description. — Crystals are octahedral in habit, with the edges replaced by the rhombic dodecahedron; other forms are rare, as is also the rhombic dodecahedral habit. Some simple rhombic dodecahedrons

are found at the Tilly Foster mine, New York.

In twinning magnetite follows the spinel law, in which the twinning plane is parallel to an octahedral face, and when this is repeated polysynthetically, the crystals are striated parallel to an octahedral



FIG. 435. — Magnetite Crystals from the Tilly Foster Mine, Brewster, New York.

edge. Large deposits of magnetite are usually granular, coarse or fine; or massive with a parting or laminated structure. Its natural magnetism serves to distinguish it from all other black minerals with the exception of franklinite, some specimens of which are quite as magnetic as magnetite.

In rock sections when well crystallized magnetite appears either square or with six-sided outlines, and is always opaque; also as rounded grains, irregular masses, or very fine disseminated opaque specks.

In rock magmas when there is an excess of iron over silica to form metasilicates this excess usually separates as magnetite. Magnetite is one of the first minerals to separate on consolidation. It, however, may contain as inclusions both zircons and apatite, earlier

products of crystallization, but less often will it contain silicates. It may be found as inclusions in most of the silicates and quartz. Large deposits of magnetite have resulted from this magmatic differentiation, as in the Kirunavaara district of Sweden, where one ridge of magnetite has been estimated to contain 740 millions of tons. The value of magnetite as an iron ore and in the production of steel depends largely upon the impurities in the form of sulphur and phosphorus which it may contain, even though these are present in only a fraction of a per cent. The sulphur may be oxidized in the Bessemer process and carried off in the slag. The phosphorus is not so easily handled, and very little renders the ore less fit for the production of steel by this process. When titanium is present to the amount of several per cent. the blast furnace is in danger of freezing, owing to the high fusing point of the slag.

Magnetite deposits in the Eastern states extend from northern New York through the intervening states to Alabama. Those deposits connected with the basic igneous rocks are generally ti-

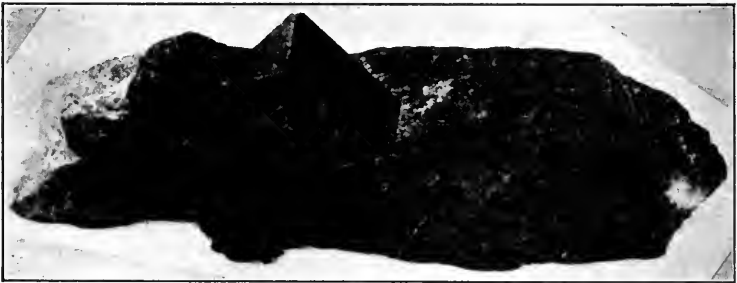

FIG. 436. — Magnetite twinned after the Spinel Law, from Brewster, New York.

taniferous, while those connected with the gneisses and limestones are non-titaniferous and are therefore more valuable to the iron industry. Magnetite in small amounts is very widely distributed as a secondary product derived from the alteration and oxidation of such minerals as pyrite, siderite, garnet, augite, olivine, amphibole, or biotite. Owing to its high specific gravity and proneness to decomposition or solution, it remains behind as a component of the black sands arising from the weathering of metamorphic and igneous rocks.

Lodestone is a variety of magnetite which is a natural magnet, showing polarity; good specimens are found at Magnet Cove, Arkansas. It is thought that the unknown people of the Southwest,

precursors of the American Indian, must have used this natural magnet to orient their temples, as they are all placed parallel to the magnetic meridian. Magnetite may be formed artificially by the fusion of an iron silicate with lime. A large number of basic rocks fused in this way will yield magnetite. The black scales formed on red-hot iron when cooling are magnetite.

FRANKLINITE

Franklinite. — $(\text{Fe} . \text{Mn} . \text{Zn}) (\text{Fe} . \text{Mn})_2\text{O}_4$; Isometric; Type, Diteséral Central; Common forms, *o* (111), *d* (110), other forms rare; Cleavage, octahedral parting; Brittle, fracture conchoidal to uneven; *H.* = 5.5–6.5; *G.* = 5.07–5.22; Color, iron-black to brownish black; Streak, brown to black; Luster, metallic; Opaque.

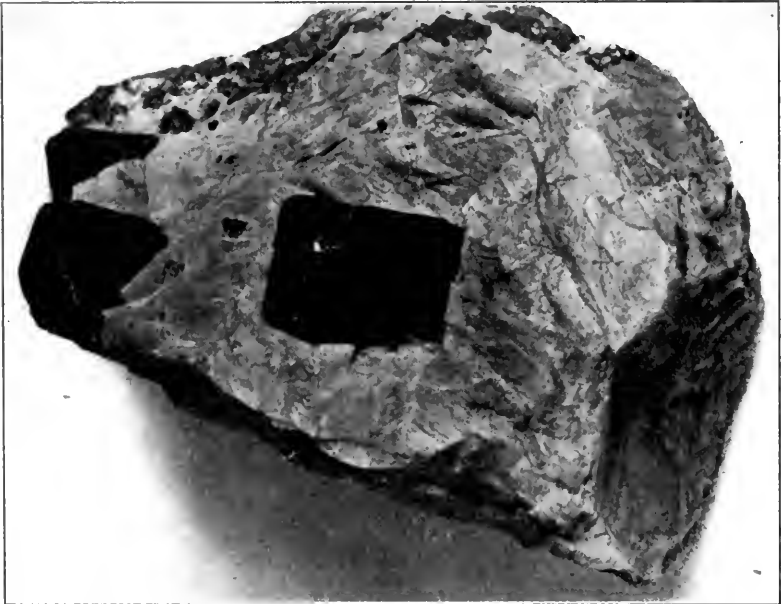

FIG. 437. — Crystals of Franklinite in Calcite. Franklin, New Jersey.

B.B. — Infusible; fused with soda in the O. F. shows green sodium manganate. Fused with borax and soda in the R. F. on coal yields a zinc coat. Slowly soluble in hot HCl. Some specimens are quite magnetic.

General description. — Octahedral in habit with the edges rounded as if fused, or truncated with the rhombic dodecahedron;

other forms as the cube, tetragonal and trigonal trisoctahedrons, occur but are very rare; also granular or massive.

The only deposit of franklinite of any importance is at Franklin and Stirling Hill, New Jersey, where it occurs in lens-shaped masses, in a crystalline limestone, and associated with willemite and zincite. This deposit has been worked for years. After the separation of the willemite and zincite mechanically, the zinc is volatilized and collected either as oxide or spelter as the case may be; the residual, iron and manganese, is reduced to "spiegeleisen," an alloy used in the Bessemer steel process.

CHROMITE

Chromite. — Ferrous chromite, FeCr_2O_4 ; $\text{FeO} = 32.0$, $\text{Cr}_2\text{O}_3 = 68.0$; Isometric; Type, Ditesseral Central; Common forms, $o(111)$, $d(110)$; Cleavage, none; Brittle, fracture uneven; $H. = 5.5$; $G. = 4.32-4.57$; Color, brownish black to gray or yellowish; Luster, metallic to submetallic, dull or greasy; Streak, brown to grayish brown; Opaque.

B.B. — Infusible; with borax in O. F. yields an emerald green bead, which treated with KNO_3 in O. F. and dissolved in water and several drops of acetic acid yields a yellow precipitate with lead acetate (PbCrO_4). Insoluble in acids, but easily decomposed when fused with sodium peroxide.

General description. — Crystals are octahedral in habit; other forms even in combination are rare. Chromite is more often massive, granular, or disseminated in rounded grains.

In rock sections it appears usually in scattered rounded grains; in very thin sections it may be brown or reddish in color, but opaque otherwise, and not to be distinguished from magnetite except by means of chemical tests.

Chromite is associated with the basic magnesian rocks, as peridotites and their alteration products, like serpentine, and while widely distributed in small amounts there are no large deposits in the United States. It is mined in small amounts in California, but most of the chrome ore used is imported from New Caledonia, Greece, Canada, Newfoundland, and Portuguese Africa.

Crystals occur at Texas, Lancaster County, and massive in various localities in Chester County, Pennsylvania; at Baltimore, Maryland; also at the Reed Mine, Hartford, Maryland; in North Carolina and Wyoming.

Chromite is used in the making of ferrochrome, in the steel industry. It is the source of all chromium salts, which are used extensively as pigments and oxidizers. The powdered mineral is made into bricks with tar as a binder, which are used in furnaces where a refractory lining is required to resist the corrosive action of the fused charge.

Chromite, like magnetite, resists decomposition by weathering and is therefore a component of many residual sands, some of which are of commercial value for their chrome content.

Other members of the spinel group are rare in occurrence and are unimportant minerals. Gahnite, $ZnAl_2O_4$, the zinc spinel, is found at Franklin, New Jersey; at the Canton mine, Georgia; in Mitchell County, North Carolina. When the molecule contains manganese and iron as well as zinc it is known as dysluite, $(Zn.Mn.Fe)(Al.Fe)_2O_4$, a variety of gahnite also found at Stirling Hill, New Jersey.

CHRYSOBERYL

Chrysoberyl. — $Be(AlO)_2$, $BeO = 19.8$; $Al_2O_3 = 80.2$; Orthorhombic; Type, Didigonal Equatorial; $\check{a} : \check{b} : \check{c} = .470 : 1 : 0.580$; $100 \wedge 110 = 25^\circ 10'$; $001 \wedge 101 = 50^\circ 59'$; $001 \wedge 011 = 30^\circ 7'$; Forms, **a** (100), **o** (111), **m** (110), **n** (121); Twinning plane, 031; Cleavage, 011 distinct and 010 less so; Brittle, fracture uneven; $H. = 8.5$; $G. = 3.5-3.85$; Color, various shades of green, brown, yellow, and sometimes red; Streak, white; Luster, vitreous; Transparent to translucent; $\alpha = 1.747$; $\beta = 1.748$; $\gamma = 1.7565$; $\gamma - \alpha = .009$; $2V = 45^\circ 20'$; $2E = 84^\circ 43'$; Axial plane = 010; $Bx_a = \bar{b}$; Optically (+).

B.B. — Infusible; powdered and ignited with cobalt solution becomes blue. Dissolves slowly in the S. Ph. bead. Insoluble in acids.

General description. — Crystals are usually tabular parallel to the macropinacoid, with striations parallel to the \check{c} axis. Twins are common, both contact and penetrating, often repeated, yielding a six-sided pseudohexagonal shape. In these twins the face **a** (100) is common to all the individuals and will locate the direction of the \check{c} axis in each by its striations.

Chrysoberyl is a rare mineral found in granites and pegmatites, where it is associated with such minerals as tourmaline, beryl,

garnet, and columbite, as at Haddam, Connecticut; and found also in granite at Saratoga, New York; at Norway, and Stoneham, Maine.

Alexandrite is a transparent variety from Takowayo in the Urals in Russia, named for the Czar Alexander II. It is a gem of great beauty, being a fine green by daylight, and in artificial light changes to a raspberry-red. The cat's-eye is an opalescent variety of chrysoberyl, the best specimens of which are obtained from Ceylon. It has been used as a gem in the East from the earliest times.

CHAPTER IX

CARBONATES

CALCITE

Calcite. — Calcium carbonate, CaCO_3 ; $\text{CaO} = 56$, $\text{CO}_2 = 44$; Hexagonal; Type, Dihexagonal Alternating; $c = .8542$; $0001 \wedge 10\bar{1}1 = 44^\circ 36'$; $r \wedge r' = 74^\circ 55'$; $e \wedge e' = 45^\circ 3'$; $v \wedge v' = 75^\circ 22'$; Common forms, r ($10\bar{1}1$), m ($10\bar{1}0$), e (0112), f ($02\bar{2}1$), y (3251), v ($21\bar{3}1$), a ($11\bar{2}0$), c (0001); Twinning planes, $10\bar{1}1$, 0001 , $10\bar{1}2$; Cleavage, rhombohedral (r) perfect; Brittle, fracture conchoidal, but difficult; $H. = 3$; $G. = 2.713$; Color, white and pale shades of yellow, brown, red, purple, or gray according to the impurities; Streak, white; Luster, vitreous; Transparent to opaque; $\epsilon = 1.487$; $\omega = 1.659$; $\omega - \epsilon = .172$; Optically (-).

B.B. — On heating whitens and becomes opaque, yielding a calcium flame; after ignition reacts alkaline with turmeric paper. Dissolves in cold dilute HCl with effervescence, yielding CO_2 ; when pure leaves no residue. Calcite may be distinguished from aragonite by treating the fine powder in dilute cobalt solution in the cold; aragonite becomes lilac-colored, which remains on boiling; calcite remains white in the cold solution and becomes blue on boiling. If powdered calcite is heated in a solution of ferrous sulphate, it precipitates a yellow ferric hydroxide, while aragonite will produce a green precipitate of ferrous hydroxide.

General description. — Calcite crystals are very rich in forms; some 330 forms have been described, with about one hundred additional forms which are doubtful. With so many possible forms it can be imagined that, while occurring very widely distributed, the crystals of many localities are combinations locally peculiar.

Four general habits may be recognized: 1. Rhombohedral; several rhombohedrons occur as simple crystals as e , f , or r . The flat rhombohedron e occur as a simple crystal and in flat combinations, in West Cumberland, England, where they are known as nail-head spar, from their resemblance to the old hammer-made wrought-

iron nails. The sharp rhombohedron *f* occurs as a simple form in the Fontainebleau sand crystals, while the cleavage rhombohedron *r* occurs as a simple form at Sterlingbush, New York; from this locality individual crystals weighing nearly a thousand pounds have been obtained, mostly rhombohedral in form with but slight modifications. In many localities this rhombohedron is the predominating form, as at Rossie, St. Lawrence County, New York, where *r* is well developed but with the equatorial belt highly modified with scalenohedrons. Since the cleavage of calcite is so perfect and in every specimen may be recognized either by the internal

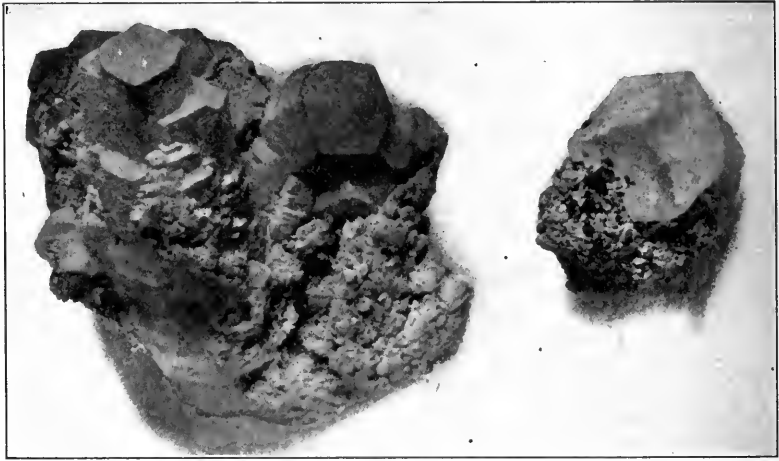

FIG. 438. — Prismatic Habit of Calcite, Wanlockhead, Scotland. The Small Specimen is the Rhombohedron *e*, Freiberg, Saxony.

fractures or by the brilliant cleavage surfaces, other forms occurring may usually be oriented by their relation to this cleavage rhombohedron *r* ($10\bar{1}1$) or the commonly occurring prism *m* ($10\bar{1}0$).

2. Prismatic crystals owe their general appearance to the predominating prism *m* which may be terminated by the simple rhombohedron *e*, as at Keokuk, Iowa, or at Freiberg, Saxony. Again the termination may be by the rhombohedron and base, as at Patterdale, England; or complicated by the combination of several scalenohedrons and rhombohedrons, as at Patterdale and Derbyshire, England.

3. When the prism is very short and terminated by the base, or small modifications of a scalenohedron, or rhombohedron in combination with these two predominating forms, the crystalline habit

is tabular, as at Andreasberg in the Harz, also in West Cumberland, England.

4. Calcite crystals of the scalenohedral habit, designated "dog-tooth spar," is probably the most common. In this form the scalenohedron v ($2\bar{1}\bar{3}1$) is the predominating form. At Tavetsch, Switzerland, this scalenohedron occurs uncombined. Nearly simple scalenohedrons of large size but slightly modified on the



FIG. 439. — Calcite Rhombohedron r , and Epidote from Sulzbachthal, Tyrol.

apex by rhombohedrons and very flat scalenohedrons occur at Joplin, Missouri, also at Mineral Point, Wisconsin. Very acute scalenohedrons occur at Thunder Bay, Lake Superior. Probably the clearest and most beautiful specimens of this habit are those of West Cumberland, England.

Twinning. — 1. Twins in which the vertical axis \bar{c} is the twinning axis and the base is the composition face. The reëntrant angle appears in the plane of the lateral axes as in Fig. 295, which are twinned scalenohedrons from Guanajuato, Mexico.

2. When the twinning axis is the normal to e , and the face e ($01\bar{1}2$) is the composition plane. In these twins the vertical axes of the two individuals stand at an angle of $52^{\circ} 30' 30''$. Fig. 294 are scalenohedrons from Mexico, twinned after this law. This style of twins also forms the polysynthetic twins of rock-forming calcite and the parting noticed in some calcites as that from Franklin,

New Jersey. Some very large rhombohedrons twinned after this law were taken from a cave in the Joplin district of Missouri.



FIG. 440. — Calcite with a Scalenohedral Habit. Cumberland, England.

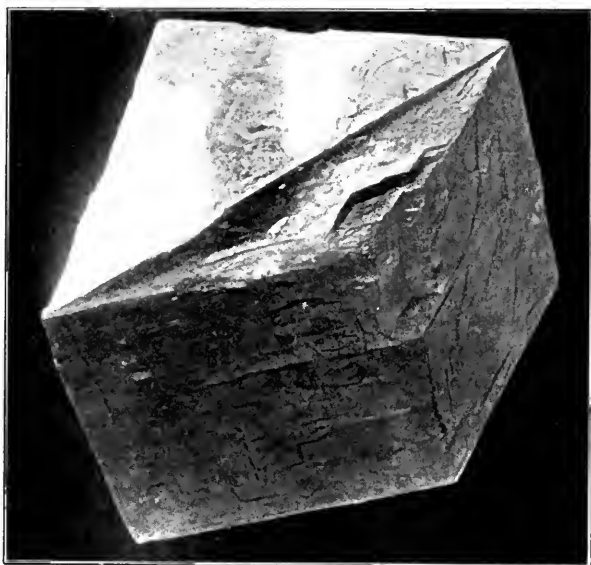

FIG. 441. — Calcite twinned on the Rhombohedral Face e (01 $\bar{1}2$). Joplin, Missouri.

3. Twins in which the twinning axis is normal to the face of the rhombohedron r (1011) are not uncommon; here the vertical axes of the two individuals lie at an angle of $90^{\circ} 46'$, as shown in Fig. 442, which are twins from Cumberland, England.

4. Twins in which the twinning axis is normal to (0221) are rare. In this type the angle between the ϵ axes is $53^{\circ} 46'$.

In rock sections calcite is colorless between crossed nicols and yields a gray interference color of high order. The relief is high when the ray is vibrating parallel to ω , and the marked cleavage cracks and surface scratches are all distinct; by a rotation of the section through an angle of 90° the marks are less distinct, as the ray is now vibrating parallel to ϵ , which is the fast ray having the least index of refraction. The cleavage parallel to r is nearly always to be noted in sections, and in many cases polysynthetic twinning lamellæ parallel to the rhombohedron e appear as light and dark bands when between crossed nicols.

Owing to the high double refraction, even thin basal sections of calcite yield good interference figures, with one or more colored rings.

Occurrence. — Calcium carbonate is very widely distributed; as massive rock it forms the large beds of limestone, which crystallizes to marble when associated with metamorphism. As a product derived from the weathering and solution of many silicates containing calcium, calcite may occur filling the cracks, veins, and cavities in almost any rock, and it is therefore a very common vein filler, associated with quartz, sulphates, sulphides, fluorite, oxides, carbonates, and other oxidized vein minerals. Calcium carbonate is soluble in water containing CO_2 as calcium bicarbonate, $\text{Ca}(\text{HCO}_3)_2$, and is the cause of the temporary hardness of natural waters; on boiling such hard waters the excess CO_2 is driven off and the water becomes milky by the precipitation of calcium carbonate; from cold solutions calcite is formed, and from hot solutions, aragonite.



FIG. 442. — Calcite twinned on r (1011). Cumberland, England.

the orthorhombic calcium carbonate. Some stalactites or stalagmites may be calcite and others aragonite according to the temperature at which they were formed. The large caves so common in limestone regions owe their origin to the solubility of the rock in the

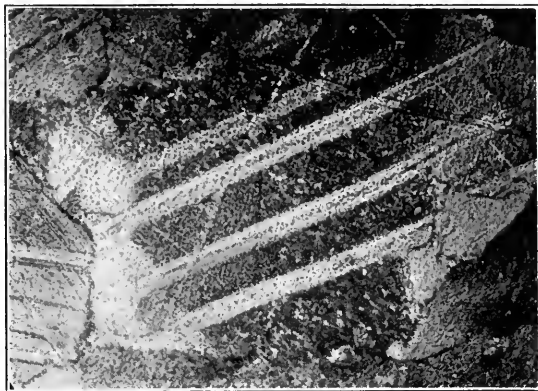

FIG. 443. — A Section of Calcite, Crossed Nicols, showing Twinning Bands parallel to the Rhombohedron e (0112).

natural ground waters containing CO_2 , and it is carried out in solution to some locality where, by relief of the pressure and loss of CO_2 , the calcium carbonate is redeposited either as calcite or aragonite.

Calcite appears as pseudomorphs after a long list of minerals, either formed by replacement, double decomposition, or as casts filling cavities after the decomposed crystals of other species have been carried away. A beautifully clear and pure calcite occurs at Eskifjord, Iceland, known as Iceland spar. This form of calcite, like quartz, has been a great servant of science, for its perfect cleavage pieces and strong double refraction led Bartholinus and Huygens to the discovery of the law of double refraction, and later Malus to the discovery of polarized light. Iceland spar is used in the construction of the nicol prism, in the dichroscope, and for other parts of optical apparatus. Unfortunately the Iceland deposit has been exhausted and calcite suitable for optical instruments is very expensive, and hard to obtain at any price. Good crystals of calcite are to be obtained at numerous localities in the United States; noted localities are Rossie and Sterlingbush, New York; Joplin, Missouri; Thunder Bay, Lake Superior; Mineral Point, Wisconsin. Calcite may appear massive, oölitic, pisolitic, or sta-

lactitic, as from the caves of Kentucky. Chalk is a soft, earthy variety derived from the shells of organisms.

Uses. — Limestone is used in the building industries not only as a building stone, but it is heated to drive off the carbon dioxide, when quicklime (CaO) remains; this is slaked with water and mixed with sand for mortar; or is sintered with eight or nine per cent. of clay and then ground, forming Portland cement, of which nearly fifty millions of barrels are used annually in the United States, and which now largely replaces the older quicklime mortars. Quicklime is often air-slaked and applied to the soil as a fertilizer to correct the acidity and as an aid in liberating combined potassium, in a form in which it is available for plant growth.

Granular limestones and marbles are crystalline limestones; their color varies with the impurities they contain, and some have a very pleasing effect as ornamental and building stones. When very pure, white, and of an even texture, as Carrara marble, it is used by sculptors as statuary marble. There is a deposit of statuary marble in Colorado said to equal, if not to surpass, in quality that of the noted quarries of Carrara, Italy. Limestone is also used as a flux in blast furnaces, where it combines with the silica of the ore to form a fusible slag. Limestones are quarried in many states, but the center of the industry is around Rutland, Vermont. Tennessee produces colored marbles in large quantities, and California the onyx variety.

Artificial. — Calcite forms from ordinary solutions of calcium bicarbonate at low temperatures; if heated or at temperatures near the boiling point, aragonite will form. Calcite will also form in a fusion with alkaline carbonates, while from an alkaline solution aragonite will form.

MAGNESITE

Magnesite. — Carbonate of magnesium, $MgCO_3$; $Mg = 47.6$, $CO_2 = 52.4$; Hexagonal; Type, Dihexagonal Alternating; $c = .8112$; $0001 \wedge 10\bar{1}1 = 43^\circ 7' 45''$; $r \wedge r' = 72^\circ 36'$; Forms r (1011), m (1010), c (0001); Cleavage, rhombohedral perfect; Brittle, fracture conchoidal; H. = 3.5–4.5; G. = 3–3.12; Luster, vitreous to dull and earthy; Transparent to opaque; Color, white, gray, or brown; $\epsilon = 1.515$, $\omega = 1.7171$, $\omega - \epsilon = .202$, Optically (—).

B.B. — Reacts like calcite, but dissolves in dilute HCl more slowly. Becomes flesh-colored when heated with cobalt solution,

and the concentrated HCl solution yields no precipitate with H_2SO_4 . Yields no flame coloration in the forceps.

General description. — Magnesite is rarely crystalline. The best crystals, which are simple rhombohedrons, occur in a chloritic schist at Hall in the Tyrol; they are of a light brownish color, contain 10 per cent. of ferrous carbonate, and are known as breunerite.

The massive magnesite is dull white or gray and very tough. It is formed by the same agencies as calcite, but naturally from the decomposition of minerals or rocks rich in magnesium; it is therefore associated with serpentine, olivine, and garnets, in talcose and chloritic schists. White magnesite occurs in Massachusetts, Pennsylvania, and Maryland. All magnesite mined in the United States is from the California deposits, especially those of Tulare and Santa Clara Counties. The imported magnesite is obtained from Greece and Austria.

Uses. — In addition to being the source of all magnesium salts, calcined magnesite, made in the form of bricks, is used as a refractory lining in the basic open hearth furnaces, in cement kilns, or as a lining to resist chemical corrosion at high temperatures, as its fusing point is about 2250° .

Artificial. — If a solution of magnesium carbonate in water is heated to 300° with a porous stopper, allowing the CO_2 to escape gradually, small rhombohedral crystals of magnesite will form. They are also formed when sodium carbonate, magnesium chloride, and water are heated in a sealed tube to a temperature of 160° to 200° .

DOLOMITE

Dolomite. — Pearl spar; Calcium magnesium carbonate, $CaMg(CO_3)_2$; Ca = 30.4, Mg = 21.7, CO_2 = 47.8; Hexagonal; Type, Hexagonal Alternating; $\dot{c} = .832$; $0001 \wedge 10\bar{1}1 = 43^\circ 51' 37''$; $r \wedge r' = 73^\circ 45'$; Forms, c (0001), m ($10\bar{1}0$), r ($10\bar{1}1$); Twinning, like calcite; Cleavage, rhombohedral perfect; Brittle, fracture subconchoidal; H. = 3.5–4; G. = 2.8–2.9; Color, various shades of gray, light yellow, and brown; Luster, pearly to vitreous; Streak, white; Transparent to opaque; $\omega = 1.682$; $\epsilon = 1.502$; $\omega - \epsilon = .180$; Optically (–).

B.B. — Infusible, whitens by loss of CO_2 and reacts alkaline with

turmeric paper. Insoluble in dilute HCl, but effervesces in hot acid. The concentrated HCl solution yields a white precipitate with $\text{H}_2\text{SO}_4(\text{CaSO}_4)$.



FIG. 444. — Dolomite. Traversella, Switzerland.

General description. — In habit, generally in simple rhombohedrons which may occur in complex aggregates, with curved, warped, or saddle-shaped surfaces; this warped appearance of the crystal faces may occur in any of the species of the rhombohedral group of carbonates, but is especially characteristic of dolomite and siderite. Dolomite, while placed in the calcite group, is not an isomorphous mixture of the two carbonates, but a double salt. This is not only shown by the difference of symmetry, but by the specific gravity of dolomite (2.85) being higher than would be required by the molecular mixture (2.843). That magnesium carbonates do enter the calcite molecule and form isometric mixtures is shown by

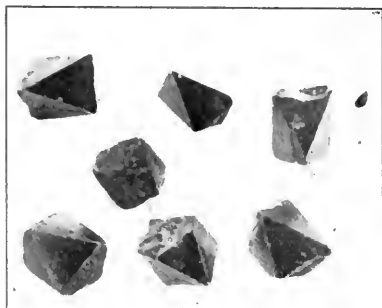

FIG. 445. — Dolomite Var. Teruelite. Teruel, Spain.

almost any analysis of calcite; most of the magnesian limestones are of this nature. Beds of dolomitic limestone are formed by the replacement of calcium carbonate with magnesium carbonate in coral reefs. This can take place in solutions of $MgCl_2$ and $MgSO_4$ common in sea water, and especially in the presence of CO_2 and at a temperature of 20° to 25° C.

Mountain ranges in the West are formed by dolomite in which the rivers have eroded steep walled cañons, which, with the cross valleys and tributary streams, cover the country with the peculiar butte formations; such a section in the Tyrol is known as the Dolomites.

An interesting variety of nearly black dolomite, teruelite, occurs at Teruel, Spain, in a matrix of gypsum. The crystals are combinations of an acute rhombohedron and the base equally developed, resembling very closely the octahedron, but the basal faces are always rough and quite different from the rhombohedron.

Uses. — Massive dolomites are very desirable as building stones.

SIDERITE

Siderite. — Chalybite; Spathic iron ore; Ferrous carbonate, $FeCO_3$; $FeO = 62.1$ ($Fe = 48.2$), $CO_2 = 37.9$; Hexagonal; Type, Dihexagonal Alternating; $c = .8184$; $0001 \wedge 10\bar{1}1 = 43^\circ 22'$



FIG. 446. — Fluorite and Siderite. Harz Mountains, Germany.

51''; $r_A r' = 73^\circ 0'$; Common forms, $r(1011)$, $c(0001)$; Twinning plane, $e(0112)$; Cleavage, rhombohedral perfect; Brittle, fracture uneven; H. = 3.5-4; G. = 3.83-3.88; Color, various shades of brown and gray; Streak, white unless oxidized, when it may be brown; Luster, vitreous; Translucent; $\omega = 1.873$, $\epsilon = 1.633$; $\omega - \epsilon = .240$; Optically (-).

B.B. — Loses CO_2 and blackens. In R. F. becomes magnetic. Fuses at 4.5 and reacts for iron with the fluxes. Effervesces in dilute HCl, especially when hot, and dissolves completely when pure.

General description. — Crystals are simple rhombohedrons or complex crystals, which are curved rhombohedrons as in dolomite. Simple rhombohedral crystals of half a pound in weight occur embedded in the cryolite of Ivigtut, Greenland. At the Buckler's



FIG. 447. — Cryolite and Siderite from Ivigtut, Greenland.

Mine, Cornwall, England, crystals, combinations of the rhombohedron, base, hexagonal prism, and a scalenohedron occur, but forms other than the rhombohedron are rare. Siderite is also massive, granular, or disseminated.

The various colors depend upon the amount of oxide of iron, or oxidation, and at times it is very dark, due to the presence of hematite or limonite, to which it is easily transformed by oxidation.

When mixed and crystallized with MgCO_3 , it forms mesitite, as at Traversella in Piedmont, which has a rhombohedral habit and is theoretically iron and magnesium carbonates in molecular proportions. Ankerite is a mixture of calcium, iron, and magnesium carbonates, occurring with iron ores and siderite, as in Styria, Siegen, Nova Scotia, and northern New York.

Siderite like other carbonates is deposited from the bicarbonate solution, but in this case it must be laid down under non-oxidizing conditions or in the presence of organic matter, otherwise hematite or limonite will form, as ferric carbonate is not known as a dry salt. It is also formed by the replacement of calcium in calcite



FIG. 448. — Siderite, showing the Hexagonal Prism and Base. Cornwall, England.

and limestones and is therefore an important constituent of many sedimentary rocks, especially those of the coal formations. Siderite as a vein filler is associated with many ore deposits.

Uses.—It is mined as an iron ore in Cornwall, England, but it is of little importance as an iron ore in the United States. Formerly it was mined at Roxbury, Connecticut.

Artificial.—Microscopic crystals may be obtained by precipitating a solution of ferrous sulphate with sodium bicarbonate and heating in a sealed tube to 150° for several hours.

RHODOCHROSITE

Rhodochrosite.—Manganese carbonate, MnCO_3 ; Mn = 61.7, CO_2 = 38.3; Hexagonal; Type, Dihexagonal Alternating; $c = 8184$; $0001 \wedge 10\bar{1}1 = 43^\circ 22' 50''$; $r \wedge r' = 73^\circ 0'$; Forms,

r ($10\bar{1}1$), e ($\bar{1}1\bar{1}2$); Cleavage, rhombohedral perfect; Brittle, fracture uneven; $H.$ = 3.5–4.5; $G.$ = 3.45–3.60; Color, various shades of red or pink, yellowish gray, brown when oxidized; Streak, white; Transparent to opaque; ϵ = 1.597; Optically (–).

B.B. — Blackens and decrepitates, infusible; with the fluxes reacts for manganese. Dissolves in hot dilute HCl with effervescence, yielding carbon dioxide.

General description. — Crystals are not common, but in habit are simple rhombohedrons; other forms are rare. Complex warped rhombohedrons of a beautiful pink color occur in Saguache County, also dark rose-colored transparent rhombohedrons associated with cubes of pyrite at Alicante, Lake County, Colorado. At Butte, Montana, the simple rhombohedrons are coated with quartz. Fine specimens are obtained from Franklin Furnace, New Jersey, where large masses of cleavable calcite occur, colored pink with manganese carbonate which has crystallized with it as an isomorphous mixture.

These mixtures of calcium and manganese carbonates are given definite names when the amount of manganese reaches a considerable percentage, as manganocalcite for the 25 per cent. mixture, or manganosiderite when much iron is present.

Rhodochrosite is formed under the same conditions as the other rhombohedral carbonates, as it is more stable than the ferrous carbonate; when they are contained in the same solution, the iron is deposited first, and the manganese may be carried in solution much farther from the original source. Owing to this difference of stability in solution the two are almost always deposited apart.

Artificial. — Microscopic rhombohedrons may be formed by heating a solution of manganese chloride and sodium carbonate in a closed tube to 160° C.

SMITHSONITE

Smithsonite. — Dry bone, Carbonate of zinc, $ZnCO_3$; ZnO = 64.8, CO = 35.2; Hexagonal; Type, Dihexagonal Alternating; c = .8063; $0001_A 10\bar{1}1 = 42^\circ 57' 20''$; $r_A r' = 72^\circ 20'$; Forms, r ($10\bar{1}1$), e ($011\bar{2}$), v ($21\bar{3}1$); Cleavage, rhombohedral perfect; Brittle, fracture, uneven; $H.$ = 5; $G.$ = 4.3–4.45; Color, white, yellow, green, brown; Streak, white or pale; Luster, vitreous to dull; Transparent to opaque; ϵ = 1.618; Optically (–).

B.B. — Infusible; reduced with soda and borax on coal yields a white coat which becomes green with cobalt solution (Zn). Dissolves in hot dilute HCl, completely when pure, with effervescence yielding carbon dioxide. Highly colored green varieties contain copper; the brown, iron or manganese.

General description. — Crystals are not common, but occur in small simple rhombohedrons, or scalenohedrons, as at Friedensville, Pennsylvania. Smithsonite is more often massive, incrustated, botryoidal, banded, or earthy, than crystalline. The pure zinc carbonate is white, and the mineral owes its various colors to the impurities and isomorphous carbonates which crystallize with it. A very beautiful green variety containing considerable copper occurs at Kelley, New Mexico; also in Greece. The bright yellow variety, known in Arkansas and southern Missouri as "turkey-fat ore," is colored with the sulphide of cadmium, greenockite, which is associated in small amounts with the zinc ores of this region.

Smithsonite is connected with most zinc ore deposits as a secondary mineral, a surface oxidation product derived from sphalerite, after which pseudomorphs are common. Zinc may be carried, by percolating waters, in solution, either as the sulphate or bicarbonate, to be precipitated as sulphide or by replacement of carbonate of lime as carbonate. Zinc ores therefore fill veins, pockets, or lenses in limestones, and may have been concentrated from the limestone itself or carried to it from neighboring regions. As a vein mineral smithsonite is associated with calcite, barite, siderite, galena, pyrite, most of which have originated through the same agencies.

Smithsonite as a zinc ore is of minor importance in the United States. It is mined in Virginia, Pennsylvania, Arkansas, and Colorado.

Its synthesis is effected by the same means as the other carbonates of the group.

Sphærocobaltite, a carbonate of cobalt isomorphous with the calcite group, is found in small rhombohedral crystals at Schneeberg in Saxony. Some rhodochrosites contain small quantities of cobalt.

ARAGONITE

Aragonite. — Calcium carbonate, CaCO_2 ; $\text{CaO} = 56\frac{1}{2}$, $\text{CO}_2 = 44$; Orthorhombic; Type, Didigonal Equatorial; $\tilde{a} : \tilde{b} : \tilde{c} =$

.6224 : 1 : .7205; $100 \wedge 110 = 31^\circ 54'$; $001 \wedge 101 = 49^\circ 10' 42''$; $001 \wedge 011 = 35^\circ 46' 30''$; Common forms, *c* (011), *b* (010), *m* (110), *o* (112), other forms numerous but not common; Twinning plane, 110, often repeated; Brittle, fracture subconchoidal; H. = 3.54; G. = 2.93-2.95; Color, white, yellow, gray, sometimes green; Streak, white; Luster, vitreous; Transparent to opaque; $\alpha = 1.529$; $\beta = 1.681$; $\gamma = 1.685$; $\gamma - \alpha = .156$; Optically (-); $2V = 18^\circ 11'$; Axial plane parallel to 100; Bx_a parallel to *c*.

B.B. — Like calcite.

General description. —

Crystalline habit prismatic, combinations of the unit prism with the brachypinacoid; as the prism angle is $116^\circ 12'$, the crystals have a hexagonal outline. Such combinations terminated by the base are common at Herregrund, Hungary. At Cleator, England, crystals occur illustrating the chisel-shaped habit, where the termination is formed by the long steep pyramid (991) and dome (091), in which the dome predominates, giving the crystal the flattened or chisel appearance. Twinning in aragonite adds to the hexagonal appearance, as the composition plane is parallel to the unit prism; when repeated and joined in parallel position, yield short stout hexagonal prisms terminated by a flat face, the base. The complexity of such specimens is easily seen by the striations on the base, or by the concave or offset prism faces.

Aragonite, as the unstable form of calcium carbonate at ordinary temperatures, is less common than calcite. It is formed from hot solutions, around thermal springs, in crusts, botryoidal shapes, and peculiar coral-like masses known as "flos-ferri," or flowers of iron, from their form and association with beds of iron ore. The "sprudelstein" of the hot springs of Carlsbad, Bohemia, is aragonite, as well as the calcic skeleton of corals and the pearly lining of many shells.



FIG. 449. — Aragonite from Herregrund, Hungary.

Heretofore all non-crystalline deposits of calcium carbonate were termed aragonite, but calcite is deposited in a massive state



FIG. 450. — Chisel-shaped Crystals of Aragonite from Cumberland, England.

at low temperatures also, and the identity of such formations should be determined by actual tests (see calcite). Aragonite passes over to calcite, with which it is dimorphous, by a change of its physical properties, forming pseudomorphs, the chemical composition remaining unchanged.

Good aragonite crystals are not common; those of Herregrund are probably the best. Pseudo-hexagonal forms occur at

Aragon, Spain, where the mineral was first discovered. At Girgenti, Sicily, it occurs associated with celestite, sulphur, and gypsum. Often associated with zeolites, and in clays with gypsum.

Artificial. — When a solution of calcium bicarbonate is heated above 30° C., aragonite separates; below 30° , calcite separates.

WITHERITE

Witherite. — Barium carbonate, BaCO_3 ; Ba = 77.7, CO_2 = 22.3; Orthorhombic; Type, Didigonal Equatorial; $\bar{a} : \bar{b} : \bar{c} = .6032 : 1 : .7302$; $100 \wedge 110 = 31^{\circ} 6'$; $001 \wedge 101 = 50^{\circ} 26' 30''$; $110 \wedge 001 = 36^{\circ} 8' 15''$; Common forms, **c** (001), **m** (110), **b** (010); Twinning plane parallel to 110; Cleavage, **b** distinct, **m** imperfect; Brittle; Fracture, uneven; H. = 3–3.75; G. = 4.29–4.35; Luster, vitreous; Color, white, gray, or yellow; Streak, white;

Transparent to translucent; $\beta = 1.740$; Optically (-); Axial plane parallel to 010; $Bx_a = \dot{c}$; $2E = 26^\circ 30'$.

B.B. — Fuses easily to a globule and yields a green flame in the forceps. After ignition reacts alkaline with turmeric paper. Effervesces with cold dilute HCl; the solution greatly diluted yields a white precipitate with H_2SO_4 .

General description. — Witherite occurs, as a rule, not in well-formed crystals, but in masses with a radiated, columnar, botryoidal, or granular structure. When crystals are well developed, they are pseudohexagonal in shape, from the repeated twinning parallel to 110.

Its genesis and associations are like aragonite, but it occurs more often in veins with barite and galena. By the action of waters containing sulphates in solution witherite will be transformed to barite. Witherite is not a common mineral, and it occurs in the United States in but few localities, as at Lexington, Kentucky, and near Thunder Bay, Lake Superior. At Fallowfield, England, it is mined commercially; splendid crystals are obtained at this locality.

It is isomorphous with aragonite and alstonite or bromlite; $(Ba, Ca) CO_3$ is such a mixture, found in pseudohexagonal crystals at Alston Moore, England, while barytocalcite, $BaCa (CO_3)_2$, is probably a double salt and monoclinic in symmetry.

Witherite is the source of barium salts; it is used as a substitute in paints, and in powder as a rat poison.

Artificially it is formed when the carbonate is fused with sodium chloride, or in the precipitation of a hot solution of barium salts by ammonium carbonate.

STRONTIANITE

Strontianite. — Strontium carbonate, $SrCO_3$; Sr = 70.1, $CO_2 = 29.9$; Orthorhombic; Type, Didigonal Equatorial; $\dot{a} : \dot{b} : \dot{c} = .6090 : 1 : .7238$; $100_A 110 = 31^\circ 20' 30''$; $001_A 101 = 49^\circ 55' 30''$; $001_A 011 = 35^\circ 54'$; Common forms, c (001), b (010), m (110), i (021); Twinning plane, 110; Cleavage, prismatic good; Brittle; Fracture, uneven; H. = 3.5–4; G. = 3.68–3.71; Luster, vitreous; Color, white, yellow, gray, pale green; Streak, white; Transparent to translucent; $\alpha = 1.515$; $\beta = 1.664$; $\gamma = 1.666$;

Optically (-); Axial plane parallel to 100; $Bx_a = \dot{c}$; $2E = 10^\circ 36'$.

B.B. — Fuses in the forceps with difficulty and yields a deep red flame; after ignition reacts alkaline with turmeric paper. Effervesces in cold dilute HCl.

General description. — Crystals are often sharply pointed in habit, caused by the development of the acute pyramid and brachydome, as at Hamm in Westphalia, also columnar, fibrous, or granular.

It is isomorphous with barium and calcium carbonates and usually contains some of these salts. In its occurrence it is associated with galena in ore deposits, and with barite and celestite; from the latter it may have been derived as a secondary product, as at Mount Bonnell near Austin, Texas; occurs also in Jefferson County, New York, and in Monroe County, Michigan.

Strontianite is the commercial source of the salts of strontium, which are used to produce the red fires in pyrotechnics. The hydrate is used in the beet sugar industry to precipitate the sugar from the molasses; for this purpose barium hydrate, owing to its cheapness, is sometimes used as a substitute.

Artificially produced like witherite.

CERUSSITE

Cerussite. — Carbonate of lead, $PbCO_3$; $PbO = 83.5$, $CO_2 = 16.5$; Orthorhombic; Type, Didigonal Equatorial; $\dot{a} : \dot{b} : \dot{c} = .6099 : 1 : .7230$; $100 \wedge 110 = 31^\circ 22' 55''$; $001 \wedge 101 = 49^\circ 51'$; $001 \wedge 011 = 35^\circ 52'$; Common forms, $c(001)$, $m(110)$, $b(010)$, $P(111)$ $i(021)$; Twinning plane, 110; Cleavage, m and i distinct; Brittle; Fracture, conchoidal; $H. = 3-3.5$; $G. = 6.46-6.57$; Color, white, yellow, or gray; Streak, white; Luster, adamantine to resinous; Transparent to opaque; $\alpha = 1.804$; $\beta = 2.076$; $\gamma = 2.078$; Optically (-); Axial plane parallel to 010; $Bx_a = \dot{c}$; $2V = 8^\circ 14'$; $2E = 17^\circ 8'$.

B.B. — Darkens in the closed tube and decrepitates. On coal in R. F. reduces to malleable lead and yields a lead coat. Dissolves in dilute nitric acid with effervescence, yielding carbon dioxide.

General description.—Crystals are tabular, pyramidal, or elongated prismatic in habit. When pyramidal in habit, like other members of the group, they are pseudo-hexagonal in appearance, from the equal development of the pyramid and brachydome, as at Mies in Bohemia. When tabular, it is very apt to form stellate groups by repeated twinning after the aragonite method, but here the space between individuals is not completely filled as in aragonite, as at Mies and Příbram, Bohemia. When elongated in habit, the prism zone is deeply striated lengthwise, as at the old Wheatley



FIG. 451. — Cerussite, Twins. Mies, Bohemia.

Mine, Chester County, and Phoenixville, Pennsylvania. It occurs also in crusts, stalactitic, granular, or massive, often colored green or blue with copper carbonates.

Cerussite is associated as a secondary product in the superficial areas of lead deposits where it is formed from galena by oxidation and the action of carbonated waters, which may also form carbonates from anglesite, the sulphate of lead, after which many pseudomorphs are found.

Next to galena cerussite is the most important ore of lead and is mined at Leadville, Colorado; Arizona; and Utah.

Artificially it may be formed as aragonite.

MALACHITE

Malachite.—Basic carbonate of copper, $(\text{Cu} \cdot \text{OH})_2\text{CO}_3$; $\text{CuO} = 71.9$, $\text{CO}_2 = 19.9$, $\text{H}_2\text{O} = 8.2$; Monoclinic; Type, Equatorial; $\mathbf{a} : \mathbf{b} : \mathbf{c} = .881 : 1 : .401$; $\beta = 61^\circ 50' = 001 \wedge 100$; $100 \wedge 110 = 37^\circ 50'$; $001 \wedge 011 = 19^\circ 29'$; Common forms, c (001), a (100), b (010), m (110); Twinning plane, 100; Cleavage, basal perfect, b less so; Brittle; Fracture, uneven; $H. = 3.5-4$; $G. = 3.9-4$; Color, bright green; Streak, pale green; Luster, vitreous, silky

to dull and earthy; Translucent to opaque; $\beta = 1.87$; Optically (-); Axial plane parallel to 010; $Bx_{\alpha}Ac = 23^{\circ} 39'$ in front; $2E = 89^{\circ} 18'$; $2V = 44^{\circ} 7'$.

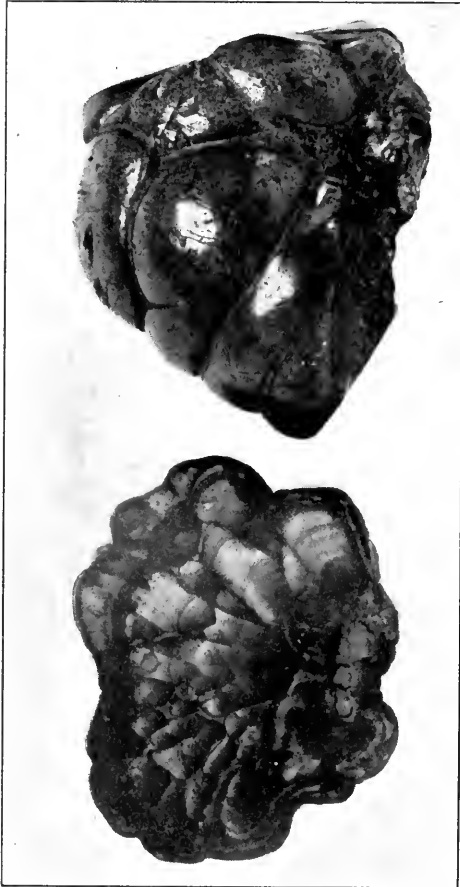

FIG. 452. — Malachite, Austria.

B.B. — Blackens and fuses. In R. F. on coal yields copper and a green flame. In the closed tube yields water, dissolves in dilute HCl with effervescence, yielding carbon dioxide.

General description. — Crystals are seldom distinct individuals, but grouped in tufts, divergent or elongated, acicular, and radiated, as at Betzdorf, in Westphalia; also botryoidal, stalactitic, nodular, and curvilinear masses, formed with concentric layers of different shades of green, are common, as at Bisbee, Arizona. Malachite is a secondary mineral formed as an oxidation product

of other copper ores, as cuprite, chalcocite, chalcopyrite, or melaconite, by the action of percolating waters charged with carbon dioxide, and is characteristic of the surface workings of all copper deposits. Numerous pseudomorphs of malachite, especially after cuprite, occur, as at Chessy near Lyons, France, where there are beautiful examples of octahedrons and rhombic dodecahedrons, some of which are only coated with a crust of carbonate, while the interior is still unaltered cuprite. Octahedral pseudomorphs are also found at Bisbee, Arizona.

Malachite is of common occurrence in many copper localities;

the most beautiful specimens in the United States are obtained at Bisbee, Arizona. The massive banded variety occurs in the Urals in Russia, where it is much prized as an ornamental stone, used in the veneering of vases, table tops, and decorations in buildings. The large interior columns of St. Isaac's Cathedral at St. Petersburg are of malachite.

Malachite is also a valuable ore of copper.

Artificial malachite is formed upon heating a solution of copper bicarbonate.



FIG. 453. — Malachite with Concentric Bands of Various Shades of Green. Bisbee, Arizona.

AZURITE

Azurite. — Chessylite; Basic copper carbonate, $\text{Cu}(\text{OH})_2 \cdot 2(\text{CuCO}_3)$; $\text{CuO} = 69.2$, $\text{CO}_2 = 25.6$, $\text{H}_2\text{O} = 5.2$; Monoclinic; Type, Equatorial; $\mathbf{a} : \mathbf{b} : \mathbf{c} = .850 : 1 : 1.880$; $\beta = 87^\circ 36' = 001_{\wedge} 100$; $100_{\wedge} 110 = 40^\circ 21'$; $001_{\wedge} 101 = 44^\circ 46'$; $001_{\wedge} 011 = 41^\circ 21'$; Common forms, \mathbf{c} (001), \mathbf{a} (100), \mathbf{m} (110), \mathbf{p} (021); Twinning plane \mathbf{v} (201); Cleavage, \mathbf{p} perfect, \mathbf{a} less so; Brittle; Fracture, conchoidal; $\mathbf{H.} = 3.5\text{--}4$; $\mathbf{G.} = 3.77\text{--}3.83$; Color, azure-blue to deep blue; Streak, smalt-blue; Luster, vitreous to dull; Translucent to opaque; Optically (+); Axial plane perpendicular to 010; $\mathbf{Bx}_{\mathbf{a}} \mathbf{c} = -12^\circ 36'$; $2\mathbf{E} = 151$.

B.B. — Like malachite.

General description. — Well-developed crystals are more common than those of malachite. They are varied in habit, and highly modified, often tabular combinations of the base and unit prism with a pyramid and dome, with the base striated, as at Bisbee, Arizona. Peculiar complex aggregates, two inches in diameter, some rhombohedral, others rounded, occur in the claylike pockets in the Copper Queen mine, Bisbee, Arizona; also at Chessy, France.

Azurite is also radiated, massive, stalactitic, granular, earthy, or botryoidal, with banded concentric layers like malachite, from which such specimens may form by a loss of CO_2 and hydration.



FIG. 454. — Azurite Crystals. Bisbee, Arizona.

Azurite is a secondary mineral formed from other copper minerals in which the chemical reactions have gone a step farther than in malachite, and some of the CO_2 has been replaced by hydroxyl.

Azurite is widely distributed in the superficial workings of almost all copper deposits.

Commercially it is an important ore of copper, and, like malachite, the well-banded and colored specimens are used in the manufacture of trinkets, ornaments, and the less expensive jewelry.

NATRON

Natron. — Hydrrous sodium carbonate, $\text{Na}_2\text{CO}_3 \cdot 10 \text{H}_2\text{O}$; $\text{Na}_2\text{O} = 21.7$, $\text{CO}_2 = 15.4$, $\text{H}_2\text{O} = 62.9$; Monoclinic; Type, Equatorial; $\mathbf{a} : \mathbf{b} : \mathbf{c} = 1.482 : 1 : 1.400$; $\beta = 58^\circ 52' = 001 \wedge 100$; $100 \wedge 110 = 51^\circ 46'$; $001 \wedge 011 = 50^\circ 10'$; Common forms, \mathbf{b} (010), \mathbf{m} (110), \mathbf{e} (011); Cleavage, basal distinct; Brittle; Fracture, conchoidal; H. = 1-1.5; G. = 1.42-1.46; Color, white

to gray or yellow; Streak, white; Luster, vitreous to dull; Transparent to earthy.

B.B. — Soluble in water, yielding an alkaline solution; effervesces with dilute acids. In the forceps a sodium flame. A strong alkaline taste.

TRONA

Trona. — Hydrous sodium bicarbonate, $\text{Na}_3\text{H}(\text{CO}_3)_2 \cdot 2\text{H}_2\text{O}$; $\text{Na}_2\text{O} = 41.2$, $\text{CO}_2 = 38.9$, $\text{H}_2\text{O} = 19.9$; Monoclinic; Type, Equatorial; $\mathbf{a} : \mathbf{b} : \mathbf{c} = 2.846 : 1 : 2.969$; $\beta = 77^\circ 23' = 001 \wedge 100$; Common forms, $c(001)$, $a(100)$, $o(\bar{1}11)$; Cleavage, \mathbf{a} perfect; $H. = 2.5-3$; $G. = 2.11-2.14$; Color, white, gray, yellowish; Streak, white; Luster, vitreous; Translucent.

B.B. — Like natron.

GAYLUSSITE

Gaylussite. — Hydrous sodium calcium carbonate, $\text{Na}_2\text{Ca}(\text{CO}_3)_2 \cdot 5\text{H}_2\text{O}$; $\text{CaCO}_3 = 33.8$, $\text{Na}_2\text{CO}_3 = 35.8$, $\text{H}_2\text{O} = 30.4$; Monoclinic; Type, Equatorial; $\mathbf{a} : \mathbf{b} : \mathbf{c} = 1.489 : 1 : 1.444$; $\beta = 78^\circ 27' = 001 \wedge 100$; $100 \wedge 110 = 55^\circ 35'$; $001 \wedge \bar{1}01 = 49^\circ 44'$; $001 \wedge 011 = 54^\circ 45'$; Common forms, $c(001)$, $e(011)$, $m(110)$, $r(\bar{1}12)$; Cleavage, prismatic perfect, basal difficult; Brittle; Fracture, conchoidal; $H. = 2-3$; $G. = 1.93-1.95$; Color, white, gray, yellowish; Streak, white; Luster, vitreous; Translucent.

B.B. — Whitens and fuses to a white enamel, yielding an intense yellow flame (Na); the residue after fusion reacts alkaline with turmeric paper. Soluble in acids with effervescence; the solution made alkaline with ammonia yields a precipitate with ammonium oxalate (Ca).

General description. — Natural soda occurs in numerous localities where the dryness of the climate has permitted the concentration or complete evaporation of large bodies of saline waters. In the West such deposits occur in Wyoming, Nevada, Utah, and at Mona, Borax, and Owens lakes, California. Most of these localities have been worked commercially for the sodium carbonates they contain. It has been estimated by Loew that Owens

Lake contains in solution 22 million tons of dry sodium carbonate. Near Ragtown, Nevada, crusts of trona exists over the surface of Soda Lake, of sufficient thickness and strength to bear the weight of a man.

A third sodium carbonate, thermonatrite, $\text{Na}_2\text{CO}_3 \cdot \text{H}_2\text{O}$, with one molecule of water, is deposited from these solutions under favorable conditions. Of the three carbonates, trona is the first to be deposited; as concentration increases, the very soluble natron separates, mixed with sulphates and chlorides.

Gaylussite is deposited in these lakes near the entrance of small streams or springs; as the waters of these, carrying calcium in solution, are mixed with the strong soda solution, the calcium salt is deposited as gaylussite.

All these large bodies of alkaline carbonates have been attributed to the concentration of solutions from volcanic rocks, or by the interaction of calcium bicarbonates in solution with alkali sulphates and chlorides.

CHAPTER X

SILICATES, TITANATES, ETC.

FELDSPARS AND LEUCITE

THE FELDSPARS

THE feldspars constitute a most important group of rock-forming minerals, so important that not only is nearly 60 per cent. of the igneous rocks composed of feldspars, but their classification depends to a great extent upon the quantity and species of feldspar that is present. They are isomorphous in the fullest sense of the term, and even though they belong to both the monoclinic and triclinic systems and are also salts of two silicic acids, yet they mix in all proportions, forming solid solutions. One species grades gradually into the others. The various mixtures which seem to be more constant in nature have been given special names, and in the past were considered as distinct species.

From a chemical standpoint there are four species, two of which, orthoclase and albite, are salts of the trisilicic acid ($H_4Si_3O_8$) while the other two, anorthite and celsian, are salts of orthosilicic acid (H_4SiO_4).

Since they form a compact isomorphous group, they are very similar in all their physical and crystallographical properties.

The following table will show very clearly these relations and will also serve for their microscopic identification.

ORTHOCLASE

Orthoclase. — Potassium aluminium trisilicate; $KAlSi_3O_8$; $K_2O = 16.9$, $Al_2O_3 = 18.4$, $SiO_2 = 64.7$; Monoclinic; Type, Digonal Equatorial; $\mathbf{a} : \mathbf{b} : \mathbf{c} = .658 : 1 : .555$; $\beta = 116^\circ 3'$; $001 \wedge \bar{1}00 = 100 \wedge 110 = 30^\circ 36'$; $001 \wedge \bar{1}01 = 50^\circ 17'$; $001 \wedge 011 = 26^\circ 31'$; Common forms, \mathbf{c} (001), \mathbf{b} (010), \mathbf{m} (110), \mathbf{x} ($\bar{1}01$), \mathbf{y} ($\bar{2}01$), \mathbf{n} (011), \mathbf{o} (111); Twinning common, composition face \mathbf{b} twinning axis \mathbf{c} (Carlsbad twins), composition face \mathbf{n} with twinning axis $\perp \mathbf{n}$

FELDSPARS

SPECIES	FUSIBILITY	COMPOSITION	GRAVITY	%SiO ₂	INDICES OF REFRACTION				χ_{2V}	EXTINGUISHING ANGLES REFERRED TO CLEAVAGE			OPTICAL CHARACTER	AXIAL ANGLES			$\chi_{001 \wedge 010}$ CLEAV. ANGLE
					a	β	γ	$\gamma - a$		on (001) + b cleavage	on (010) and c	B _a \wedge \bar{a}		a	β	γ	
Orthoclase . . .	about 1150°	KAlSi ₃ O ₈	2.55	64.7	1.519	1.524	1.526	.007	69° 43'	0°	+5°	85° from \perp (001) 21° from \perp (010)	-	90°	116° 3'	90°	90°
Microcline . . .	about 1150°	KAlSi ₃ O ₈	2.55	64.7	1.522	1.526	1.529	.007	83° 41'	+15°	+5°	\parallel to \bar{a} + nearly \parallel to b	+	90°	116° 3'	90°	89° 30'
Albite (Ab) . . .	about 1150°	NaAlSi ₃ O ₈	2.605	68.7	1.525	1.530	1.531	.006	77° 39'	+5°	+19°		-	94° 3'	116° 29'	88° 9'	86° 24'
Oligoclase . . .	1340°	Ab ₃ +An	2.649	62.0						+1°	+1½°		-	93° 4'	116° 23'	90° 5'	86° 8'
Labradorite . . .	about 1475°	An ₇ +Ab	2.72	49.3						-18°	-29°		+	93° 31'	116° 3'	89° 54'	86° 4'
Anorthite (An)	1532°	CaAl ₂ Si ₂ O ₈	2.76	43.2	1.574	1.579	1.586	.012	77° 18'	-37°	-36°		-	93° 13'	115° 55'	91° 12'	85° 50'
Celsian . . .	?	BaAl ₂ Si ₂ O ₈	3.34	32.0	1.583	1.588	1.594	.011	80° 22'	0°	+28°		+	90°	115° 2'	90°	90°

(Baveno twins), composition face c with twinning axis $\perp c$ = (Manebach twins); Cleavage, basal perfect, b less so and M imperfect; Brittle; Fracture, uneven; $H.$ = 6; $G.$ = 2.55; Color, white to light yellow, pink, or red and gray; Streak, white; Luster, vitreous; Transparent to opaque; α = 1.519; β = 1.524; γ = 1.526; $\gamma - \alpha$ = .007; Optically (-); Axial plane perpendicular to 010; $Bx_a \Delta a$ = $5^\circ - 7^\circ$ in the obtuse angle β ; $2V$ = $69^\circ 43'$; $2E$ = 120° .

B.B. — Fuses at 5, about $1150^\circ C.$, rounds on thin edges. With potassium flux and the blue glass shows potassium flame. Insoluble in acids.

General description. — Crystals when well formed are generally combinations of c , m , b , y , or x , elongated parallel to the clin-

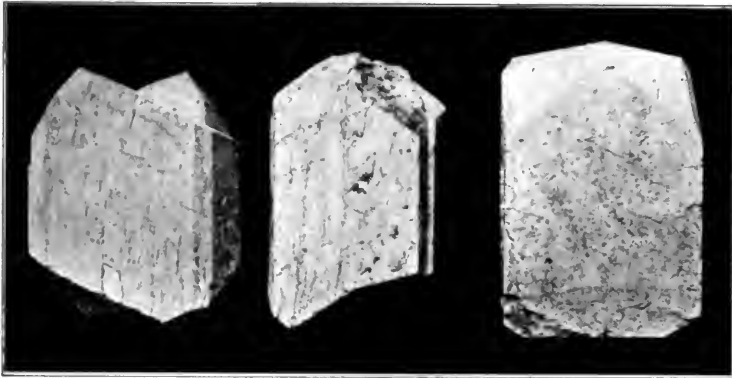

FIG. 455. — Crystals of Orthoclase. Two are Carlsbad Twins, Brice, New Mexico.

axis; or less often parallel to the vertical axis. At times the forms o and n appear; other forms are rare. Crystals are short and stout; when elongated parallel to the clinaxis they have a square cross section; again they may be tabular, flattened parallel to the base or clinopinacoid. Orthoclase also occurs massive, granular, flint- or jasper-like. Twinning is very common, after three laws which are important.

1. The Carlsbad law, where the twinning axis is the vertical axis, with the composition plane parallel to the clinopinacoid. They may be either interpenetrating or contact twins, and if repeated polysynthetically produce the banded appearance between crossed nicols so common to the feldspar on the base or basal cleavage faces parallel to the clinopinacoid. Carlsbad twins are the most

commonly occurring twins in orthoclase. The name is derived from Carlsbad in Bohemia, where they are found in great perfection.

2. Baveno law, twinning axis perpendicular to n (021), with n as the composition plane. Since the angle $n \wedge n' = 89^\circ 13'$ or nearly 90° , the outward form of the square section perpendicular to the clinaxis is not changed. As the composition plane passes diagonally across the prism face M , making unequal angles with the two faces, upon a revolution of 180° around the twinning axis there will appear in the twin crystal a reëntrant angle at one extremity much larger than at the other. This habit of twinning may be repeated with the other diagonal of the square section as the twinning plane, when the crystal will be composed of four individuals. The name is derived from Baveno in Piedmont, where the pink granite quarries furnish many fine crystals twinned after this law.



FIG. 456. — Baveno Twins of Orthoclase, from Baveno.

3. Manebach law, twinning axis is perpendicular to the base and the composition face is the base. Since the base and clinopinacoid are at right angles, the square section of the crystal is not changed, but the form which terminates the crystal will show a reëntrant angle at one extremity only. When developed polysynthetically, the twinning planes will appear on the clinopinacoidal cleavage faces and not on the basal cleavage.

In sections, orthoclase when fresh is colorless and transparent, but often milky or cloudy through kaolinization. In many cases the crystal sections will show numerous fine inclusions of hematite, which may impart a slight reddish tinge to the mineral. Orthoclase seems to possess the peculiar habit of collecting these oxide of iron inclusions from the magma, and when porphyritic the individual crystals may be pink to red in color from the numerous inclusions.

In most rocks orthoclase is one of the last minerals to crystallize and therefore may include such minerals as magnetite, zircons,

apatite, micas, pyroxene, or amphiboles; or it may form a ground mass filling in the cavities between the crystals of earlier crystallization.

In many instances quartz and orthoclase crystallize simultaneously and in eutectic proportions, forming intergrowths of the two species, termed pegmatites, which

when fine in structure are micropegmatites. Cleavage is always present, and at right angles when the section is perpendicular to 001. Interference colors are grays of the first order, and relief is not marked. The acute bisectrix lies in the large angle β , with extinction 5°



FIG. 457.—Section of Orthoclase, showing the Low Relief and Well-developed Basal Cleavage Cracks.

from the good basal cleavage. This angle increases with the replacement of potassium by sodium, and in some specimens may be as large as 10° .

Orthoclase is the important feldspar of granites, where it crystallizes at about the same time as quartz. In the coarse crystalline pegmatites the two minerals are in eutectic proportion, two molecules of orthoclase to one of quartz, or, in composition, about 35 per cent. quartz.

Orthoclase is also formed as the result of metamorphic agencies in both the schists and gneisses of thermal or aqueous origin. Secondary orthoclase sometimes fills veins, and is also associated with metalliferous fissure veins as a gangue mineral. It is easily decomposed, yielding its alkali to solutions containing carbon dioxide, especially under pressure, when, with the separation of some silica and hydration, orthoclase forms kaolin. It is by this continuous decomposition of orthoclase that the available supply of potassium for plant growth is principally sustained in the soil; and it is well known that soils yielded by the decomposition of granites are the most fertile. Other decomposition products of orthoclase are muscovite, biotite, and gibbsite.

Adularia is a transparent orthoclase; the most noted locality is at St. Gothard in Switzerland. The name is derived from Mount Adula of that region. It occurs in crystals of an apparent rhombohedral habit, being a combination of the prism m and the base,

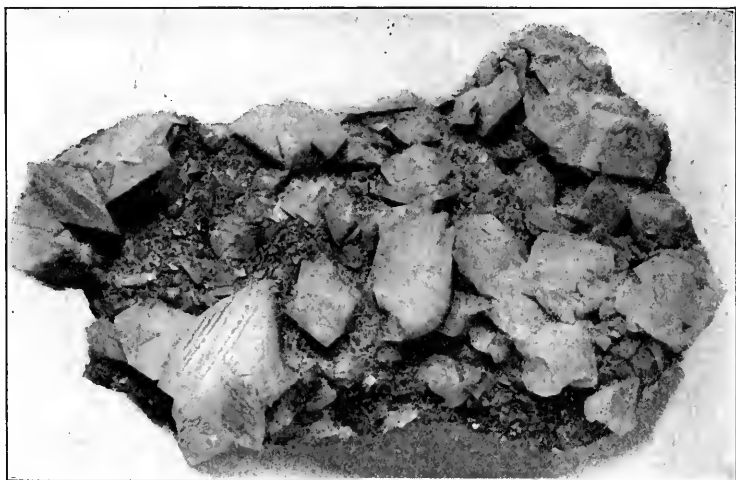

FIG. 458. — Adularia from St. Gothard, Switzerland.

nearly equally developed. The base may be distinguished by the horizontal striations.

Beautiful specimens coated with chlorite and associated with epidote occur in the Sultzbachthal, Tyrol. Adularia when cut and polished *en cabochon* is the moonstone of the jewelers.

Feldsite is a compact flint or jasper-like rock, showing no cleavage, of which the varieties rhyolite, trachyte, and phonolite have a chemical composition of an alkalic feldspar. Perthite denotes a structure made up of interlaminated potassium and sodium feldspars; when the laminae are exceedingly thin it forms microperthite.

Potassium and sodium feldspars intercrystallize, forming alkalic feldspars, while sodium and calcium feldspars intermix, forming plagioclases, or calcic feldspars; although the potassium and calcium spars are isomorphous, in nature they are seldom found intercrystallized.

Sanidine is a clear, glassy, granular orthoclase, usually associated with lavas and the later eruptive rocks. It is found in the lavas of Monte Somma, Vesuvius, in clear, colorless grains.

Uses. — Orthoclase is quarried in Maine, Massachusetts, Connecticut, Pennsylvania, and Maryland from the pegmatites, where it is associated with quartz, muscovite, and small quantities of magnetite, tourmaline, and garnets. It is ground and mixed with kaolin and quartz in the manufacture of chinaware. It is also a component of both the glaze and underglaze. It is also the flux used in the making of corundum wheels. It is used as a wood filler; in scouring soaps; and in opalescent glass. Artificially orthoclase has not been formed by the dry fusion of its components, but other chemical reagents which act as liquefiers must be added, as the alkalic feldspars are so viscous at their fusing points as to prevent crystallization in any moderate length of time. If fluorides, tungstates, or magnetite are added to the melt, or if heated in the presence of water under pressure, crystals are formed.

MICROCLINE

Microcline. — KAlSi_3O_8 ; A triclinic form of potassium aluminium trisilicate in which the cleavage angle varies by $30'$ from 90° ,

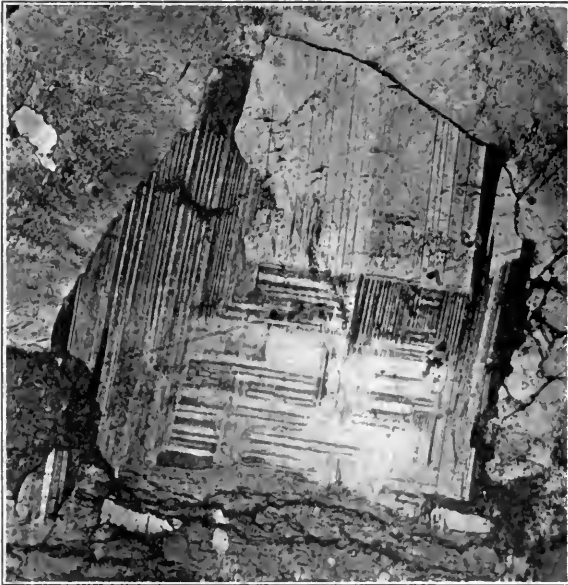

FIG. 459. — Section of a Complexly Twinned Feldspar between Crossed Nicols.

or the angle $010 \wedge 001 = 89^\circ 30'$. In all other respects it is very much like orthoclase. Their difference may be seen in the table, page 404.

Microcline is always twinned with striations differing from those of orthoclase. It has been advanced as a theory that orthoclase is a triclinic feldspar and that its monoclinic symmetry is a pseudo one, and caused by thin laminae, so thin as to be submicroscopic, and when considered from this standpoint it would not differ from microcline.

In addition to the twins found in orthoclase there are two other important twinning laws represented in the twins of microcline:

1. The albite twins, in which the twinning axis is the normal to the pinacoid 010, and the composition plane is parallel to 010; when repeated polysynthetically, this produces striations on the base and bands between crossed nicols on the basal cleavage parallel to the intersection of the basal and brachypinacoids.

2. Pericline twins, in which the twinning axis is the crystallographical axis \bar{b} and the composition plane is parallel to the axis \bar{b} and inclined to the base, at an angle depending upon the composition of the feldspar. These twins are also repeated, and produce striations and bands on both the brachypinacoidal cleavage and on the basal cleavage. Those on the base are at right angles to the striations produced by the Carlsbad and albite twins and the two sets of bands between crossed nicols from

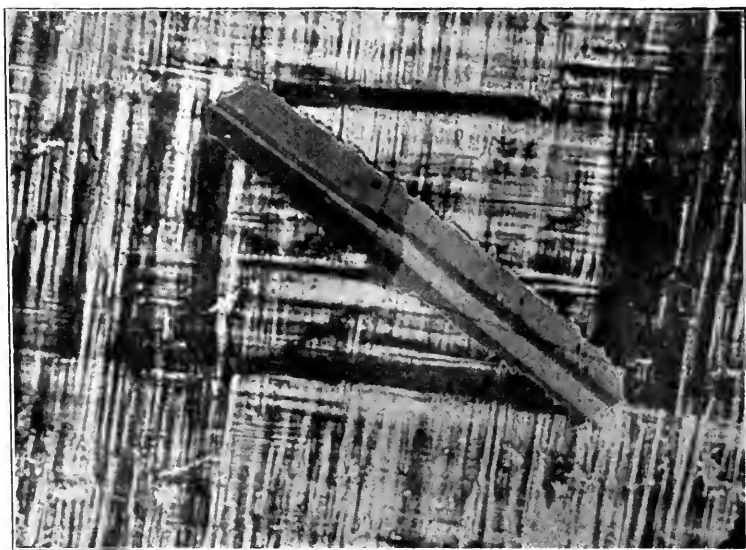

FIG. 460. — Section of Microcline, showing the Gridiron Structure and inclosing a Crystal of Plagioclase.

the well-known gridiron structure, recognized in sections and characteristic of microcline, serving as an easy means of distinguishing microcline from orthoclase.

Microcline is associated with orthoclase in the older igneous rocks, as granites and syenites, but it is not associated with sanidine in the more recent felsites and lavas.

Amazon stone is the name given to a green variety of microcline, beautiful specimens of which are obtained near Pikes Peak, Colorado; in fact most microcline is very apt to be light green in color, the cause of which is not known.

ALBITE

Albite. — Sodium aluminium trisilicate, $\text{NaAlSi}_3\text{O}_8$; $\text{Na}_2\text{O} = 11.8$, $\text{Al}_2\text{O}_3 = 19.5$, $\text{SiO}_2 = 68.7$; Triclinic; Type, Centrosymmetric; $\bar{a} : \bar{b} : \bar{c} = .633 : 1 : 558$; $\alpha = 94^\circ 3'$; $\beta = 116^\circ 29'$; $\gamma = 88^\circ 9'$; $100 \wedge 010 = 90^\circ 3'$; $100 \wedge 001 = 63^\circ 35'$; $= 010 \wedge 001 = 86^\circ 24'$; Common forms, c (001), b (010), m (110), M ($\bar{1}\bar{1}0$), x ($\bar{1}01$); Twinning, albite, Carlsbad, Baveno, and Manebach laws common, also pericline twins; Cleavage, basal perfect, brachypinacoidal less so, and m imperfect; Brittle; Fracture, uneven; H. = 6–6.5; G. = 2.6–2.65; Color, white, gray to reddish; Streak, white; Luster, vitreous; Transparent to opaque; $n_\alpha = 1.525$; $n_\beta = 1.530$; $n_\gamma = 1.531$; $n_\alpha - n_\gamma = .006$; Optically (+); $2V = 77^\circ 39'$.

B.B. — Fuses a little easier than orthoclase, insoluble in acids, and will not yield a potassium flame, at least not a strong one.

General description. — In habit albite is tabular parallel to the brachypinacoid rather than elongated, though both habits occur. Crystals are combinations of the base, brachypinacoid, and the two unit prisms; other forms are not common. Well-formed crystals occur in cavities and veins in granites, syenites, or gneisses, especially the more acid varieties, where they are associated with such minerals as topaz, beryl, tourmaline, chrysoberyl, and other rare species. In color albite is more apt to be white than is orthoclase, and the two good cleavages are not at 90° but at 86° . Twinning striations caused by twinning after the albite law are characteristic and nearly always appear on the basal cleavage. In sections albite is colorless, with very low relief, and is similar in many respects to orthoclase, with which it may be intimately intergrown in laminae parallel to the macropinacoid (perthite), or in concen-

tric layers. Since it is triclinic, extinction is always at an angle, and when measured on the basal cleavage in regard to the brachy

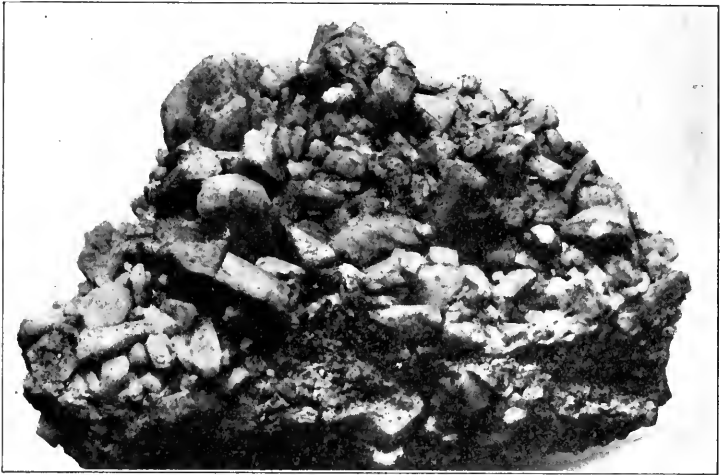

FIG. 461. — Albite from Pfitsch, Tyrol.

cleavage cracks it is 5° ; when measured on the brachy cleavage in reference to the basal cleavage cracks it is 19° . The interference color is a little higher than orthoclase, but still gray of the first order. The axial plane is nearly perpendicular to 010. The acute bisec-

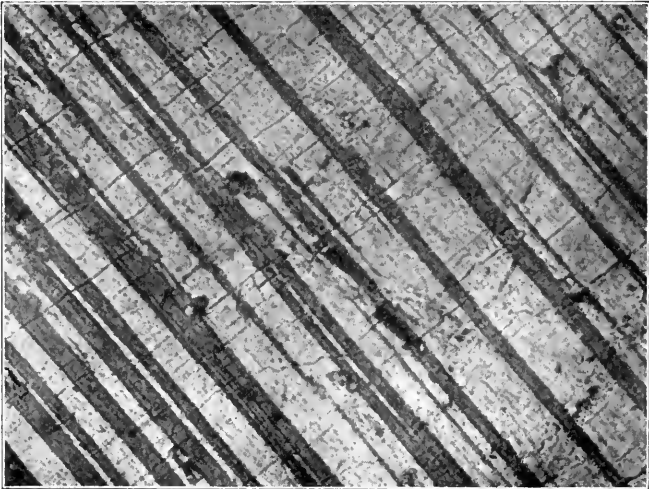

FIG. 462. — Polysynthetic Twinning in Albite, Crossed Nicols.

trix is nearly perpendicular to 100 or the **b** cleavage, the cleavage piece yielding a nearly symmetrical interference figure. Optically (+).

Albite is associated with orthoclase and microcline in the granites, syenites, gneisses, and schists, and in the microcrystalline ground mass of porphyries as well as in phenocrysts. It crystallizes with orthoclase, forming the series of alkali feldspars, and with anorthite to form the soda-lime feldspars.

In decomposing it resembles orthoclase in forming kaolin, but not quite as easily, since in the same sections the albite may appear clear and fresh, while the orthoclase will be clouded by kaolinization. It is associated with hornblende in diorite, and with pyroxene in gabbro; here the feldspars often alter to a substance known as saussurite, a mixture of albite, zoisite, etc.

Albite may also occur as a vein mineral in phyllites and clay-slates. Artificially albite is formed under the same conditions as orthoclase, except that sodium salts are substituted for potassium.

ANORTHITE

Anorthite. — Calcium aluminium orthosilicate, $\text{CaAl}_2\text{Si}_2\text{O}_8$; $\text{CaO} = 20.12$, $\text{Al}_2\text{O}_3 = 36.72$, $\text{SiO}_2 = 43.16$; Triclinic; Type, Centrosymmetric; $\bar{a} : \bar{b} : \bar{c} = .635 : 1 : .550$; $\alpha = 93^\circ 13'$; $\beta = 115^\circ 55'$; $\gamma = 91^\circ 12'$; $100 \wedge 010 = 83^\circ 54'$; $100 \wedge 001 = 63^\circ 57'$; $010 \wedge 001 = 85^\circ 50'$; Common forms, **c**(001), **b**(010), **m**(110), **M**($\bar{1}\bar{1}0$), **x**($\bar{1}01$), **y**($20\bar{1}$); Twinning, albite law common, other laws less so; Cleavage, basal perfect, 010 less so; Brittle; Fracture, uneven; H. = 6–6.5; G. = 2.74–2.76; Color, white, gray to reddish; Streak, white; Transparent to opaque; $\alpha = 1.574$; $\beta = 1.579$; $\gamma = 1.586$; $\gamma - \alpha = .012$; Optically (–); $2V = 77^\circ 18'$; Bx_a is $53^\circ 14'$ to the normal to 001 and 58° to the normal to 010.

B.B. — Fuses with difficulty (1532°C.) Decomposed with HCl gelatinizing. The solution freed of silica yields tests for calcium.

General description. — Anorthite in the pure state, unmixed with albite, is very rare; it has been described as occurring in the lavas of Monte Somma, in rounded grains and in small complex crystals, where it is associated with hornblende and biotite. It has also been identified at Raymond, Maine, in a metamorphic limestone.

Twinning is polysynthetic, after the albite law, with twinning striations on the base; other twins are not so common.

In sections anorthite is colorless and much like orthoclase in re-

lief. The interference color is first order yellow, and extinction is inclined as indicated in the table on page 404. The interference figure is yielded by a basal cleavage fragment, showing the emergency of an optic axis in the plus octant, behind, and near the edge of the field, with the plane of the optic axis running down to the right.

Anorthite is a constituent of the more basic igneous rocks, especially gabbros, basalts, and porphyrites, and it also appears in crystalline limestones. It is easily decomposed but less often alters to kaolin, forming rather zeolites and quartz.

Artificial crystals are easily obtained by the simple fusion of its constituent oxides in the right proportion, in an open crucible. Anorthite standing at the basic end of the series easily forms crystals in the simple fusion; this property is lost, however, as albite or orthoclase is approached at the acid end of the series.

Celsian, $\text{BaAl}_2\text{Si}_2\text{O}_8$, is a rare barium feldspar found at Jakobsberg in Sweden; and hyalophane is a potassium barium feldspar, $\text{K}_2\text{BaAl}_4\text{Si}_8\text{O}_{24}$, found in a crystalline dolomite at Binnenthal, Switzerland.

SODA-LIME FELDSPARS

The two feldspars albite (**ab**) and anorthite (**an**) are found in nature mixed in crystals in all proportions, and since they are solid solutions and not double salts, there are no theoretical compositions for members of the series. However, mixtures within indicated limits have received distinctive names and form a complex series grading from pure albite at one end to pure anorthite at the other.

In crystalline habit they are all much alike, having two good cleavages at approximately 86° . They all form twins after the ordinary laws, but polysynthetic twinning after the albite law with striations or bands on the basal cleavage parallel to the edge **c/b** is particularly characteristic. The variation and trend of the optical properties with the change in the composition is indicated and may be seen by an inspection of the table on page 404.

The most important members of the series, with their composition expressed in terms of albite (**ab**) and anorthite (**an**), are as follows:

Albite	ab + an ₀ to ab ₆ + an
Oligoclase	ab ₆ + an ₁ to ab ₃ + an
Andesine	ab ₃ + an to ab + an
Labradorite	ab + an to ab + an ₃
Bytownite	ab + an ₃ to ab + an ₆
Anorthite	ab + an ₆ to ab ₀ + an

OLIGOCLASE

Crystals of oligoclase are not common, but when well developed they are of the same general habit as albite. It is usually massive or cleavable. Twinning after the albite law is the common form, producing striations on the base. Pericline twins are also developed

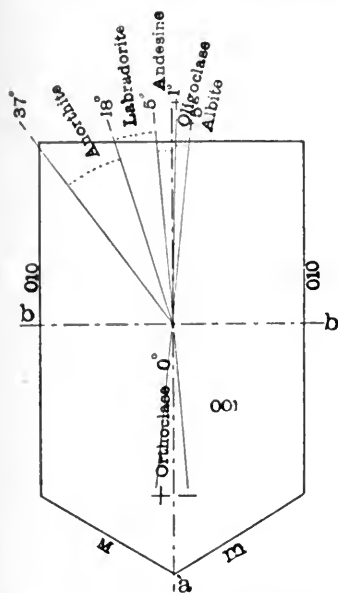

FIG. 463. — Diagram of the Extinction Angles of the Feldspars on the Base in Reference to the Pinacoidal Cleavage 010.

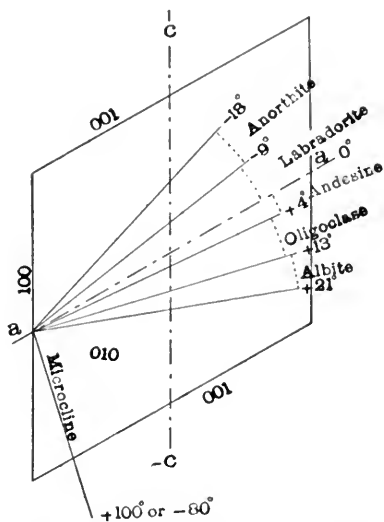

FIG. 464. — Diagram of the Pinacoidal Section 010, showing the Inclination of the Pericline Twinning Plane in Reference to the Basal Cleavage Cracks.

polysynthetically, producing striations on the brachypinacoid; the inclination of these striations to the basal cleavage cracks or to the edge c/b varies with the composition of the specimen, and is of great assistance in locating the position of the crystal in the series of plagioclases; that is, in roughly determining its composition. Fig. 463 is a diagram showing how this angle is measured in a plus or minus direction and also giving its value for each member of the series.

Oligoclase being a member of the acid end of the series is associated with orthoclase and albite in the granites, syenites, diorites, and their porphyritic equivalents, where the individual crystals usually contain large quantities of glass as inclusions.

In decomposition through weathering it usually forms kaolin, and under varied conditions forms zeolites, epidote, and quartz.

Labradorite is a rock-forming soda-lime feldspar, dark gray to nearly black in color, often showing a play of colors or iridescence. In composition it is a member of the 'basic' end of the series of

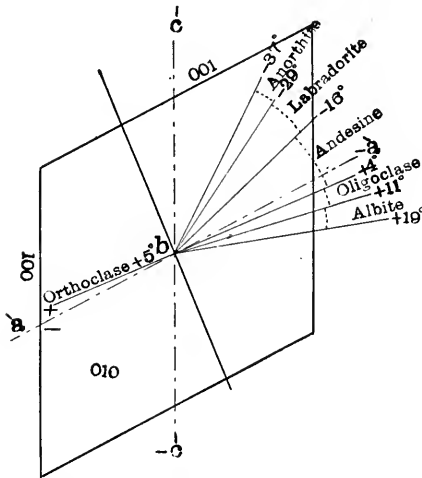

FIG. 465.—Diagram of the Pinacoidal Section 010, showing the Extinction Angles of the Feldspar in Reference to the Basal Cleavage Cracks.

plagioclases. The relation of its optical properties to other members of the series is shown in the table, page 404.

In occurrence it is associated with the more basic rocks, particularly the eruptive rocks. It is rarely associated with quartz or orthoclase. In sections it appears in characteristic lath-shaped crystals, especially in the diabases. Since the more basic feldspars are the first to crystallize from a magma, they often show zonal structure in which the central portion is labradorite, each zone outwardly becoming less basic or calcic in character. This change in composition, from basic to acid, may also take place in passing from the exterior portions of a rock mass to the interior portions. Labradorite is associated with pyroxene, amphibole, and magnetite in those rocks in which the ferromagnesian content is considerable.

LEUCITE

Leucite.—Potassium aluminium metasilicate, $KAl(SiO_3)_2$; $K_2O = 21.5$, $Al_2O_3 = 23.5$, $SiO_2 = 55$; Pseudoisometric. Forms, $n(211)$, $d(110)$, $c(100)$; Twinning plane = 110; Cleavage, 110, imperfect; Brittle; Fracture, conchoidal; H. = 5.5–6; G. = 2.45–2.5; Color, white, gray; Streak, white; Luster, vitreous; Transparent to nearly opaque; $\epsilon = 1.509$; $\omega = 1.508$; $\epsilon - \omega = .001$; Optically (+).

B.B. — Infusible (about 1400°), shows potassium with the flux and blue glass. Decomposed with HCl without gelatinization but with the separation of silica. The solution freed of silica yields a precipitate of aluminium hydroxide with ammonia. The powdered mineral often becomes blue when treated with cobalt solution.

General description. — Crystals are usually simple tetragonal trisoctahedrons, rarely in combinations with the cube or rhombic dodecahedrons; also in rounded grains, as in the lavas of Vesuvius; seldom massive. Leucite is dimorphous; the apparently simple isometric crystals at ordinary temperatures are complex aggregates of twinned lamellæ, and probably orthorhombic. When heated above 500° these complex individuals become simple isometric crystals, losing their double refraction, and are isotropic. The isometric form, being



FIG. 466. — Leucite. Vesuvius, Italy.

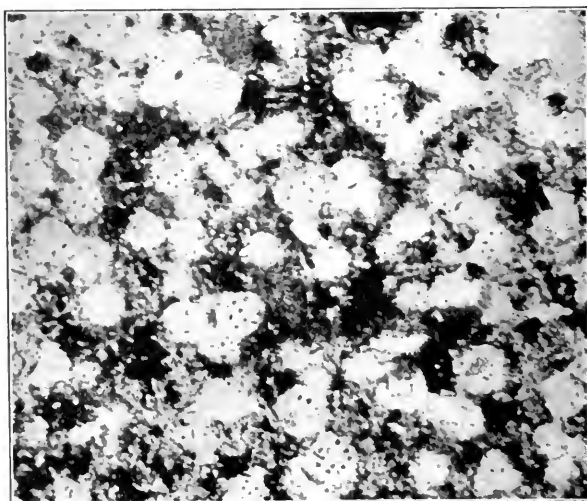

FIG. 467. — Section of a Leucite, showing Rounded Leucite Crystals with Dark Inclusions arranged Symmetrically.

stable above 500° , and the orthorhombic form the stable form below that temperature.

Leucite is a constituent of igneous rocks, especially those tertiary or recent lavas rich in potassium and aluminium in which the silica is insufficient to produce feldspars. It is associated with augite, haüynite, nepheline, olivine, apatite, and magnetite.

In rock sections the crystals appear in polygonal or nearly circular outlines, colorless and with a very low relief. Inclusions are very common and symmetrically arranged in concentric belts or radiated starlike. These inclusions may be glass or fine crystals of those minerals which have preceded the leucite in crystallization, as magnetite, apatite, or augite. Between crossed nicols the twinning lamellæ will appear in large crystals, showing an interference color

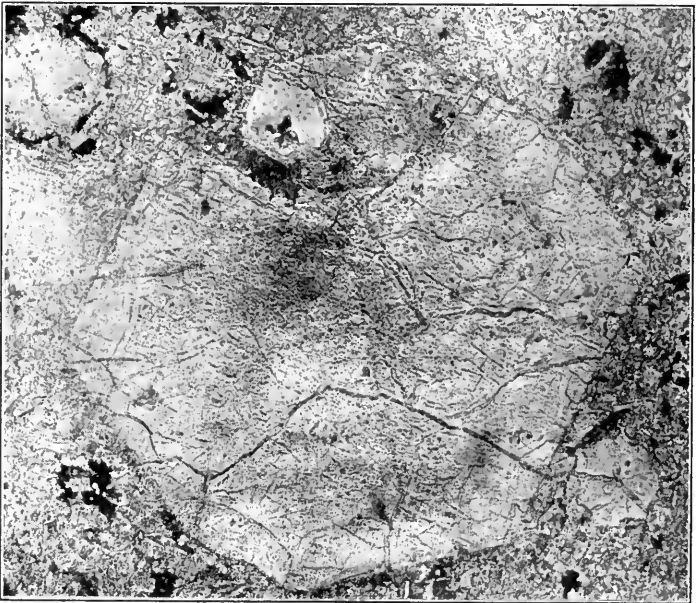

FIG. 468. — Outline of a Leucite Crystal in a Section of Porphyry.

of a very low gray of the first order, while the small rounded grains may appear as isotropic.

Leucite is easily decomposed, yielding its potassium to percolating waters, which may at the same time replace the potassium with sodium; this replacement and hydration yields analcite, which crystallizes in the same form. The leucites of the older rocks have

all had their potassium replaced at least in part in this way. In other instances leucite has produced feldspars or micas which have retained the crystalline form, producing pseudomorphs. Ultimately leucite decomposes, forming kaolin.

Artificially leucite has been produced by simply fusing its constituents in an open crucible and cooling the melt slowly; also by fusing mixtures of natural minerals, as microcline and biotite, or from the fusion of muscovite alone. When leucite is heated to 195° in a solution of sodium chloride or carbonate, analcite is formed.

PYROXENES

The pyroxenes are the most important ferromagnesian rock-forming minerals. They are essentially metasilicates of the general formula, $R''SiO_3$ in which R'' may be Mg, Ca, Fe, Mn, Zn, Na_2 , Li_2 , or the triad elements Al, Fe''' , or Mn''' , which enter with a second more or less complex, as $R'' R''' SiO_6$. Again silica may be replaced in part by Zr, Ti, or Cb.

The series in symmetry runs through the orthorhombic, monoclinic, and triclinic systems. Magnesium metasilicate is orthorhombic, calcium metasilicate is monoclinic, manganese metasilicate is triclinic, and the ferrous metasilicate has not been found unmixed with other silicates as a pyroxene, but as an amphibole. The members of the series are isomorphous, and have many characteristics in common, which may be seen by an inspection of the table which follows. They have two cleavage directions at an angle near 87° , which serves to distinguish them from the closely related forms of amphibole. In crystalline habit they are usually short, stout, prismatic, or columnar.

ORTHORHOMBIC PYROXENES

The orthorhombic pyroxenes are mixtures of the metasilicates of iron and magnesium; some calcium may enter the molecule, though always in small proportions. The two species enstatite and hypersthene in composition grade into each other, the varieties depending upon the percentage of ferrous iron present; when this amounts to 10 to 12 per cent. the mineral is known as bronzite; when much greater, hypersthene; when much less, enstatite.

PYROXENE

SYS-TEM	SPECIES	COMPOSITION	AXIAL RATIO	β	INDICES OF REFRACTION FOR SODIUM LIGHT	2V	AX PL.	$Bx_2 \wedge c$	GRAVITY
Ortho-rhombic	Enstatite	MgSiO ₃	a : b : c 1.0307 : 1 : .5885		α 1.665 β 1.669 γ 1.674	70°	010	0	3.1 - 3.3
	Hypersthene	(Mg · Fe) SiO ₃	1.0319 : 1 : .5872		α 1.662 β 1.702 γ 1.705	50°	010	90°	3.4 - 3.5
Monoclinic	Diopside	CaMg(SiO ₃) ₂	1.0921 : 1 : .5893	74° 10' 9"	α 1.6707 β 1.6776 γ 1.6906 $\alpha = 1.7320$ $\beta = 1.7366$ $\gamma = 1.7506$	59° 7'	010	in front 38°	3.11
	Hedenbergite	CaFe(SiO ₃) ₂	1.0912 : 1 : .5843	74° 35'		59° 52'	010	" 47° 10'	3.31
	Scheffelite	(Ca · Mg)(Fe · Mn)(SiO ₃) ₂	1.0988 : 1 : .5953	74° 35'		65° 3'	010	" 44° 25'	
	Jeffersonite	(Ca · Mg · Zn)(Fe · Mn)(SiO ₃) ₂	1.0921 : 1 : .5893	74° 30'	$\alpha = 1.6972$ $\beta = 1.7039$ $\gamma = 1.7227$	61° 12'	010	" 53° 22'	3.63 3.23
	Augite	CaMg(SiO ₃) ₂ Mg(Al · Fe)SiO ₃	1.0996 : 1 : .6012	73° 11'	α 1.7630 β 1.7990 γ 1.8126	62° 13'	010	" 96°	3.52
	Acmite	NaFe(SiO ₃) ₂	1.1283 : 1 : .6234	69° 32' 30"	$\alpha = 1.651$ $\beta = 1.669$ $\gamma = 1.677$	70°	010	" 26°	3.27
	Jadeite	NaAl(SiO ₃) ₂	—	—		54° +	010	"	3.17
	Spodumine	LiAl(SiO ₃) ₂	1.0963 : 1 : .7150	69° 42' 30"	$\beta = 1.75$ $\alpha = 1.700$ $\beta = 1.716$ $\gamma = 1.726$	79° 46'	010	behind 20°	3.51
	Lärvנית	Na(Mn · Ca · Fe)(Zr · O · F)(SiO ₃) ₂	1.0549 : 1 : .7091	70° 45'	$\alpha = 1.654$ $\beta = 1.651$ $\gamma = 1.677$	71° +	1 (010)	" 43° 15'	3.41
	Wöhlerite	12(Na ₂ Ca)(Si · Zr)O ₃ RNb ₂ O ₆ with F	1.1687 : 1 : .9776	78° 13'	$\alpha = 1.621$ $\beta = 1.633$ $\gamma = 1.635$	90°?	1 (010)	" 12° +	3.31
Rosenbuschite	Na ₂ Ca ₂ (Si · Zr · Ti)O ₄	1.1140 : 1 : .9864	84° 40'		60°	1 (010)	$\beta_{x\beta}$ b	2.68	
Pectolite	H NaCa ₂ (SiO ₃) ₃	1.0531 : 1 : .9676	84° 30'		2E 70°	(010)	behind 32° 12'	2.85	
Wollastonite	CaSiO ₃	—	—						
Triclinic	Rhodonite	MnSiO ₃	1.0729 : 1 : 0.6213	$\alpha = 103° 18'$ $\beta = 108° 44'$ $\gamma = 81° 30'$		76° 12'			3.4 - 3.68
	Fowlerite	(Mn · Fe · Ca · Zn · Mg)(SiO ₃) ₂	1.0786 : 1 : .6263	$\alpha = 103° 30'$ $\beta = 108° 45' 30''$ $\gamma = 81° 55' 30''$					
	Hortdahlite	4Ca(Si · Zr)O ₃ Na ₂ ZrO ₃ F ₂	.9983 : 1 : .3512	$\alpha = 80° 22' 30''$ $\beta = 90° 36' 50''$ $\gamma = 90° 5' 50''$					3.267
	Babingtonite	(Ca · Fe · Mn)SiO ₃ Fe(SiO ₃) ₃	1.0691 : 1 : .6308	$\alpha = 104° 21' 30''$ $\beta = 108° 31'$ $\gamma = 83° 34'$	1.68 + strong		111		3.36

ENSTATITE

Enstatite. — Magnesium metasilicate, MgSiO_3 ; $\text{MgO} = 40$, $\text{SiO}_2 = 60$; Orthorhombic; Type, Didigonal Equatorial; $\check{a} : \bar{b} : \check{c} = 1.0307 : 1 : .588$; $100_{\wedge} 110 = 44^{\circ} 8'$; $001_{\wedge} 101 = 30^{\circ} 29'$; $001_{\wedge} 011 = 29^{\circ} 43'$; $110_{\wedge} 110 = 88^{\circ} 16'$. Crystal forms rare, c (001), a (100), b (010), m (110); Twinning rare, forming lamellae; Cleavage, prismatic, easy; Brittle; Fracture, uneven; $H. = 5.5$; $G. = 3.1-3.3$; Color, gray, yellowish, olive to brown; Streak, white to gray; Luster, vitreous to silky, metalloid and bronze-like; Transparent to opaque; $\alpha = 1.665$; $\beta = 1.669$; $\gamma = 1.674$; $\gamma - \alpha = .009$; Optically (+); Axial plane = 010; $Bx_a = \check{c}$; $2V = 70^{\circ}$, varies with Fe present.

B.B. — Fuses with difficulty (1400°). Insoluble in acids.

HYPERSTHENE

Hypersthene. — (Mg. Fe) SiO_3 ; with FeO greater than 10 per cent. Orthorhombic; Type, Didigonal Equatorial; $\check{a} : \bar{b} : \check{c} = .9713 : 1 : .5704$; $100_{\wedge} 110 = 44^{\circ} 10'$; $001_{\wedge} 101 = 30^{\circ} 25'$; $001_{\wedge} 011 = 29^{\circ} 42'$; $110_{\wedge} 110 = 88^{\circ} 20'$; Crystals, rare; Cleavage, b perfect, m and a less so; Brittle; Fracture, uneven; $H. = 5-6$; $G. = 3.4-3.5$; Luster, pearly to metalloid, bronze-like; Color, dark brown, greenish to black; Translucent to opaque; $\alpha = 1.692$; $\beta = 1.702$; $\gamma = 1.705$; $\gamma - \alpha = .013$; Optically (-); Axial plane = 010; $Bx_a = \check{a}$; $2V = 50^{\circ}$ varies with Fe.

B.B. — Fuses with difficulty to a black slag. On coal in R. F. becomes magnetic. Partially decomposed with HCl.

General description. — These two minerals are rarely found showing crystalline faces. Large crystals of enstatite, combinations of m , a , and b , terminated by a series of brachydomes and the pyramid (223), occur at Bamle, Norway. Usually they occur lamellar, foliated or fibrous in structure, cleavable at an angle near 88° . The transition form between enstatite and hypersthene is known as bronzite from its peculiar metalloid bronze-like luster.

In sections enstatite is either colorless or pale shades of yellow or green, always much lighter than hypersthene, which is rather reddish; both are irregular or in rough crystalline outline, with relief well marked, and surface appearing rough; cleavage well

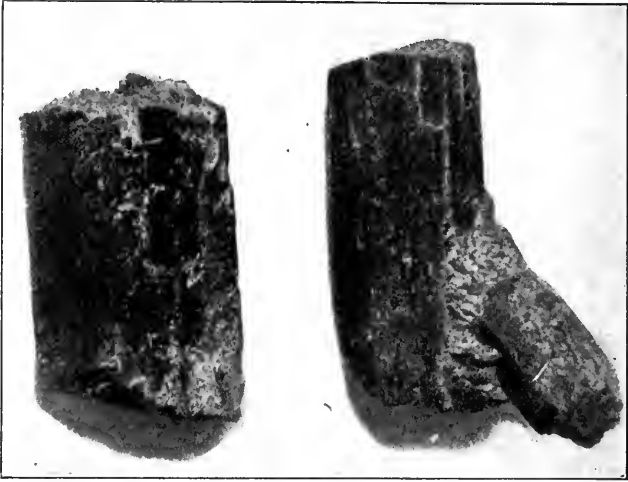

FIG. 469. — Enstatite. Bamle, Norway.

developed at an angle near 88° . Pleochroism varies with the iron content; it is almost absent in enstatite and well marked in hypersthene, changing from brown to green when parallel to the axis \hat{c} . Interference color, upper first order. The acute bisectrix in enstatite is parallel to \hat{c} , and when iron reaches 10 per cent. it changes to the axis \hat{a} .

Inclusions are very characteristic, consisting of microscopic crys-

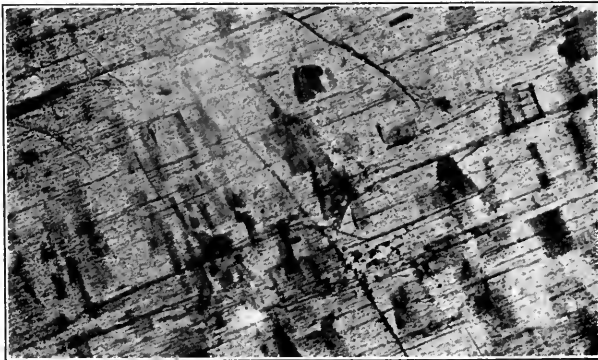

FIG. 470. — Section of Enstatite showing the Regularly Arranged Inclusions causing the "Schiller."

tals in plates, rods, or grains, arranged parallel to the brachypinacoid, producing the "schiller" so characteristic of these two

minerals. Minerals crystallizing earlier, as apatite, zircon, or magnetite, may occur as inclusions, while lamellar intergrowths parallel to 010 with monoclinic pyroxene are not uncommon.

Orthorhombic pyroxenes are common pyrogenetic constituents of igneous rocks, especially the more basic varieties, as peridotites, norites, diorites, and some syenites and their corresponding porphyries and lavas, where they are associated with monoclinic pyroxenes, olivine, plagioclases and micas, but never associated with nepheline or leucite.

In their weathering and hydration they form bastite, a fibrous substance, in composition much like serpentine; other alteration products are serpentine, talc, carbonates, iron oxides, and quartz.

Artificial. — There are four modifications of magnesium metasilicate, two of which are pyroxenes, the other two amphiboles. Of the two pyroxenes one is monoclinic, the other orthorhombic. The transition temperature between these two modifications is about 1100° C.

When magnesia, iron oxides, and silica are fused in an open crucible and allowed to crystallize near their fusing point, the monoclinic form appears. If crystallization takes place below 1100°, the orthorhombic form, enstatite, will appear.

If serpentine is fused, it breaks down, on cooling, into a mixture of enstatite and olivine.

MONOCLINIC PYROXENES

In the monoclinic pyroxenes, calcium, iron, and aluminium enter the molecule and are more important than magnesium. While the varieties thus formed agree closely in their crystallographic habit and physical properties, they differ widely in their occurrence and association. The varieties from diopside to aemite and jadeite are included under the species pyroxene and they may vary in their composition and pass one into the other gradually. Their normal compositions and relations are given in the table, page 420.

DIOPSIDE

Diopside. — Calcium magnesium metasilicate, $\text{CaMg}(\text{SiO}_3)_2$; Monoclinic; Type, Digonal Equatorial; $\alpha : \beta : \gamma = 1.0921 : 1 : .5893$; $\beta = 74^\circ 10' = 100 \wedge 001$; $100 \wedge 110 = 46^\circ 25'$; $001 \wedge 101 = 24^\circ 21'$; $001 \wedge 011 = 29^\circ 33'$; Common forms, *c* (001), *b* (010), *a* (100), *m* (110), *s* (111), *w* (111); Twinning plane 110, contact

twins and repeated, parallel to 001 producing striations and parting; Cleavage, prismatic at $87^{\circ} 12'$ perfect, α less so; Brittle; Fracture, conchoidal; H. = 5-6; G. = 3.2-3.6; Color, white, green to brown; Streak, white to gray; Luster, vitreous to dull; Transparent to opaque; $\alpha = 1.6707$; $\beta = 1.6776$; $\gamma = 1.6996$; $\gamma - \alpha = .0289$; Optically (+); Axial plane = 010; $Bx_{\alpha} \wedge c = 38^{\circ}$ in front; $2V = 59^{\circ} 70'$.

B.B. — Fusibility below five, but varies with the composition. If much iron is present, it may become magnetic in R. F. on coal. Generally insoluble in acids.

General description of the pyroxenes. — In habit the crystals are short, stout prisms, rarely much elongated except in aëmite and diallage. The pinacoids are well developed and usually terminated by the plus and minus unit pyramids. In some specimens the two end terminations may differ, indicating a symmetry lower than that of digonal equatorial. Diopside is the light-colored variety and contains but little iron and aluminium, while the dark opaque varieties are augite. Jeffersonite is a variety from Franklin, New Jersey, containing zinc; and schefferite is a manganese variety from Sweden. Hedenbergite is a dark green variety containing iron, which replaces most of the calcium; it was first described by Berzelius as from Sweden. Diallage is a variety

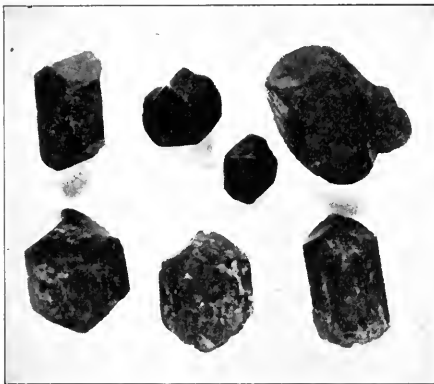

FIG. 471. — Augite Crystals. Bilin, Bohemia.

elongated in habit, and in most instances is laminated or even fibrous parallel to 010; it may be intergrown with the orthorhombic pyroxenes and exhibit the same "schiller" characteristic of those varieties.

In thin sections it is either in polygonal outline, rounded, or irregular. When crystals are well formed they are eight-sided in section, formed by the two pinacoids and the unit prism. The color varies from colorless in diopside, through various shades of green and brown, in augite or aëmite, the color depending upon the amount of iron

present. Relief is high and the sections appear very rough. Cleavage is always well developed, and in sections at right angles to the vertical axis will show the true prismatic angle of $87^{\circ} 12'$. Pleochroism is not marked. The cleavage angle and lack of pleochroism serve to distinguish the pyroxenes from the amphiboles.

Crystals may show zonal structure and intergrowths with the orthorhombic varieties. Extinction in sections parallel to the orthoaxis is either straight or bisects the cleavage angle; in all other sections there is inclined extinction, increasing to a maximum in the plane of symmetry, where it varies from 38° to

54° , according to the composition of the specimen. The acute bisectrix is in the large angle β ; the angle between it and the axis c varies with the variety, as is shown in the diagram, Fig. 473. Double refraction is strong, from .020 to .030, always yielding interference colors of at least the second order. Interference figure distinct, showing an optic axis in the basal section near the center of the field; the other axis emerges in the orthopinacoid. Optically (+).



FIG. 472. — Augite from Egausville, Renfrew County, Canada.

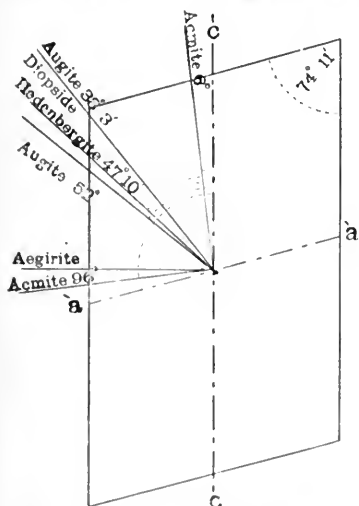

FIG. 473. — Diagram of the Plane of the Optic Axes 010, showing the Extinction of the Various Species of Pyroxenes.

The pyroxenes are constituents of the igneous rocks, especially the ferro-magnesian varieties, eruptives and lavas. They are one of the essential minerals of gabbros, where they are associated with the plagioclases, biotite hornblende, olivine, and less often, with quartz.

Diallage is the usual pyroxene of gabbro; in the diorites and norites it is associated with hornblende and hypersthene. The dark colored varieties, as augite and ægirite, are more often associated with nepheline in the clæolite-syenites and with leucite in the recent alkali lavas. Pyroxenes occur less frequently with the schists and sparingly as a metamorphic product associated with limestone. The green sodium pyroxene, jadeite, is never in individual crystals, but occurs in very tough and compact masses, breaking with a splintery fracture. It is much prized by the Chinese, who have used it for ages as a material out of which they carve ornaments. It is one of the minerals commonly known as jade. An alteration characteristic of pyroxene is uralitization, in which there is a physical change from pyroxene to a fibrous amphibole with little or no chemical change; the fibers of the uralite always lie parallel to the \hat{c} axis; the formation of epidote or zoisite may accompany uralitization. Those varieties containing much magnesium are apt, in their weathering, to form talc, serpentine, and bastite, while the calcium will form calcite; when more iron is present, biotite, chlorite, and calcite are produced.

Pyroxenes are easily crystallized from the fusion of their constituents in open crucibles. They are common minerals of blast furnace slags.

SPODUMENE

Spodumene. — Lithium aluminium metasilicate, $\text{LiAl}(\text{SiO}_3)_2$; $\text{Li}_2\text{O} = 8.4$, $\text{Al}_2\text{O}_3 = 27.4$, $\text{SiO}_2 = 64.5$; Monoclinic; Type, Digonal Equatorial; $\hat{a} : \hat{b} : \hat{c} = 1.1283 : 1 : .6234$; $\beta = 69^\circ 32'$; $001 \wedge 100 = 46^\circ 30'$; $100 \wedge 110 = 33^\circ 25'$; $001 \wedge 011 = 30^\circ 47'$; Common forms, c (001), a (100), b (010), m (110), p ($\bar{1}10^\circ$); Twinning plane parallel to 100; Cleavage prismatic 87° perfect; Brittle; Fracture, uneven; H. = 6.5–7; G. = 3.13–3.20; Color, gray, yellowish, green, or purple; Streak, white; Luster, vitreous to pearly; Transparent to opaque; for optical properties see table, page 420.

B.B. — Fuses easily to a clear glass, yielding a lithium flame especially with the potassium bisulphate flux. Insoluble in acids.

General description. — Crystals are elongated in habit, parallel to the vertical axis, with striations on the prism zone lengthwise. At times they are of enormous size, as at the Etta mine in South Dakota, where it is said that crystal faces forty feet in length have

been uncovered; the mineral is mined there for the manufacture of lithium compounds. There is a lamellar structure very often developed parallel to the orthopinacoid and when prominent yields a parting.

Spodumene occurs in the pegmatites of New England, as at Mount Mica and Windham, Maine; at Goshen, Massachusetts, and Branchville, Connecticut. In these pegmatites it is associated with

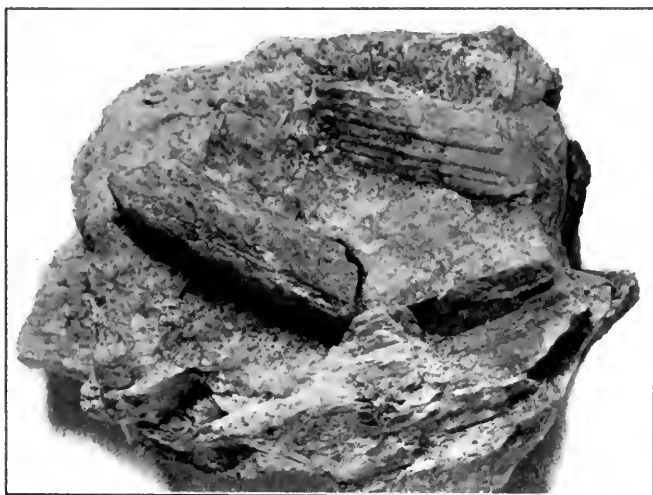

FIG. 474.—Spodumene. Goshen, Massachusetts.

tourmaline, amblygonite, lepidolite, and beryl. The green variety, hiddenite, is found in cavities in a gneiss-like rock at Stony Point, Alexander County, North Carolina, where it is associated with a clear green beryl.

Kunzite, a lilac-colored variety, is mined at Pala, San Diego County, California. Both of these clear colored varieties are used as gems; beautiful specimens have lately been discovered in a coarse pegmatite in the island of Madagascar, where they are associated with magnificent tourmalines, lepidolite, and the pink beryl (morganite).

By an interchange of alkali, spodumene alters to albite, microcline, or muscovite.

PECTOLITE

Pectolite. — An acid sodium calcium metasilicate, $\text{HNaCa}_2\text{-(SiO}_3)_3$; $\text{Na}_2\text{O} = 9.3$, $\text{CaO} = 33.8$, $\text{SiO}_2 = 54.2$, $\text{H}_2\text{O} = 2.7$; Mono-

clinic; Type, Digonal Equatorial; $a:b:c = 1.1140: 1: .9864$; $\beta = 84^\circ 40' = 001 \wedge 100$; $100 \wedge 110 = 47^\circ 57'$; $001 \wedge 101 = 39^\circ 10'$; $001 \wedge 011 = 44^\circ 29'$; Forms, c (001), a (100), h (540), q (340), w (140); Twinning plane, 100; Cleavage, a and c perfect; Brittle; Fracture, uneven; $H. = 5$; $G. = 2.68-2.88$; Color, white, gray; Streak, white; Luster, silky; Transparent to opaque; $n = 1.61$; $\gamma - \alpha = .038$; Axial plane perpendicular to 010, making an angle of 90° nearly with the axis c ; $Bx_a = \bar{b}$; $2V = 60^\circ$; Optically (+).

B.B. — Fuses quietly, coloring the flame yellow (Na). Gelatinizes with HCl; the solution freed of silica yields little or no precipitate with ammonia, but a heavy white precipitate with ammonium carbonate (calcium).

General description. — Crystals are elongated and needle-like, in radiated, nodular masses, with an opaque porcelain appearance or silky; sometimes in groups of long, slender and parallel, though

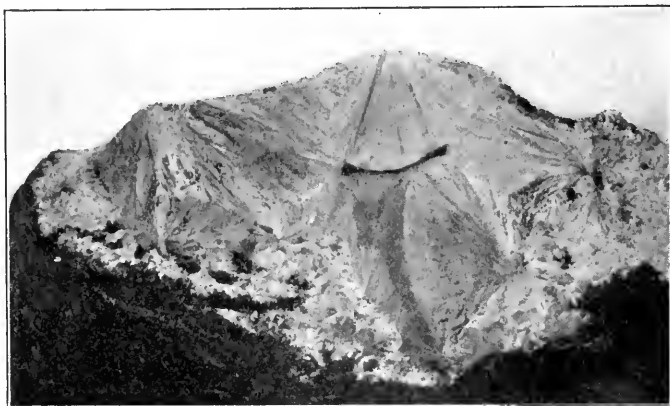

FIG. 475. — Pectolite. Franklin, New Jersey.

individual, crystals. Elongation is parallel to the orthoaxis, with the base and orthopinacoid as the prominent faces, terminated by h and w . Tabular crystals are rare, but they have been found at Bergen Hill, New Jersey.

Pectolite is found as a secondary mineral in the cracks and cavities of the basic eruptive rocks, where it has been deposited by percolating waters and associated with zeolites, calcite, apophyllite, and datolite. It is a common mineral in the traps of Bergen Hill and Paterson, New Jersey; Isle Royal, Michigan; Magnet Cove, Arkan-

sas. A massive variety has been described from Tehama County, California, and Alaska.

WOLLASTONITE

Wollastonite. — Calcium metasilicate, CaSiO_3 ; $\text{CaO} = 48.3$, $\text{SiO}_2 = 51.7$; Monoclinic; Type, Digonal Equatorial; $\mathbf{a} : \mathbf{b} : \mathbf{c} = 1.0531 : 1 : .9676$; $\beta = 84^\circ 30' = 100_\wedge 001$; $100_\wedge 110 = 46^\circ 21'$; $001_\wedge 101 = 45^\circ 5'$; $001_\wedge 011 = 43^\circ 55'$; Common forms, \mathbf{c} (001), \mathbf{a} (100), \mathbf{h} (540), \mathbf{m} (110), \mathbf{v} (101); Twinning plane, 100; Cleavage, \mathbf{a} perfect, \mathbf{c} less so; Brittle; Fracture, uneven; $H. = 4.5-5$; $G. = 2.8-2.9$; Color, white, gray, yellow, brown, or pink; Streak, white; Luster, vitreous to pearly; Translucent to opaque; $\alpha = 1.621$; $\beta = 1.633$; $\gamma = 1.635$; $\gamma - \alpha = .014$; Optically (-); Axial plane = 010; $\mathbf{Bx}_{\mathbf{a}} \mathbf{c} = 32^\circ 12'$ behind; $2\mathbf{E} = 70^\circ$.

B.B. — Fuses quietly to a white, somewhat glassy globule. Gelatinizes with HCl; the solution freed of silica yields little or no precipitate with ammonia, but a heavy white precipitate with ammonium carbonate (calcium).

General description. — In habit crystals are tabular, with the base as the prominent face, or elongated parallel to the orthoaxis; also fibrous or divergent, but usually in cleavable masses. The color is white to gray in pure material, but as iron and manganese replace the calcium the color becomes brown or pink.

Wollastonite is a characteristic mineral of contact metamorphic regions where there is an abundance of calcium; it is therefore a common mineral in crystalline limestones, where it is associated with garnets, epidote, vesuvianite, diopside, etc. It may occur in lavas and basalts, where it is associated with nepheline.

A pink variety containing considerable manganese occurs at Franklin, New Jersey. Wollastonite also occurs at various places in Lewis County, New York, in well-formed crystals; in the Lake Superior region, and at Grenville, Quebec.

There are two forms of calcium metasilicate; the β - CaSiO_3 is stable below 1190° . This form is the mineral wollastonite. The other form, α - CaSiO_3 , is pseudo-hexagonal, is the stable form above 1190° , and is formed when the constituents are fused in an open crucible and cooled quickly. It is the common form of calcium metasilicates found in slags. Wollastonite is formed when a glass of the composition of CaSiO_3 is heated to 900° or 1000° and kept

at that temperature for some time; or α - CaSiO_3 may be inverted to β - CaSiO_3 by the addition of a fluoride or boric acid and cooling slowly.

RHODONITE

Rhodonite. — Manganese metasilicate, MnSiO_3 ; $\text{MnO} = 54.1$
 $\text{SiO}_2 = 45.9$; Triclinic; Type, Centro-symmetric; $\bar{a} : \bar{b} : \bar{c} =$
 $1.0729 : 1 : .6213$; $\alpha = 103^\circ 18'$; $\beta = 108^\circ 44'$; $\gamma = 81^\circ 39'$
 $100 \wedge 010 = 94^\circ 26'$; $100 \wedge 001 = 72^\circ 36'$; $010 \wedge 001 = 78^\circ 42'$
 $100 \wedge 110 = 48^\circ 33'$; Crystal forms, c (001), a (100), b (010)
 m (110), M ($1\bar{1}0$); Cleavage, prismatic ($92^\circ 28'$) perfect, c less so:
 Brittle; Fracture, uneven; $H. = 5.5$ – 6.5 ; $G. = 3.4$ – 3.7 ; Color,
 shades of red and pink; Streak, white; Luster, vitreous to pearly,
 Translucent to opaque; Optically (–); $2V = 76^\circ 12'$.

B.B. — Fuses at three to a black slag. With borax yields a manganese reaction. Nearly insoluble in acids; some may effervesce from containing carbonates, and others (fowlerite) may yield a zinc coat on coal.

General description. — Crystals are usually large and rough, combinations of the three pinacoids, flattened parallel to the base or elongated parallel to the vertical axis. The crystal faces often appear glassy, as if fused; also massive, granular, or in rounded separate grains. On exposure the surface blackens from oxidation, and impure varieties may be yellow or green; this variation in color is due to the replacement of manganese by iron, calcium, or zinc. Fowlerite from Franklin, New Jersey, is a light-colored form containing as much as 7 per cent. ZnO ; while bustamite is a variety containing at times as much as 20 per cent. CaO .

Rhodonite is found in schists and metamorphic limestones; it is a product of contact metamorphism. At Franklin, New Jersey, it is associated with wollastonite, spinels, and garnets. At Filipstad in Sweden it is associated with the iron ores. A massive variety is mined near Ekaterinberg, Urals, Russia, and used as an ornamental stone.

In weathering the manganese forms carbonates. The silica forms a soluble silicate and quartz; when the decomposition is incomplete, the mineral is a mixture of silicate and carbonate.

AMPHIBOLES AND BERYL

AMPHIBOLES

The amphiboles are metasilicates of the formula, $R''SiO_3$ or $R'R'''(SiO_3)_2$ in which R may be Na, K, $R_2'' = Ca, Mg, Fe, Mn$, and $R''' = Al$ or Fe, or they may be mixed silicates in which there is one molecule of an ortho- and one of a trisilicate; this would yield the same proportions of silicon and oxygen. Such radicals as $(Al_2 \cdot OF_2)''$, $(Fe_2 \cdot OF_2)''$, $(Al_2O(OH)_2)''$, and $(Fe_2O(OH)_2)''$ also enter the molecule of the more complex varieties. They are distributed through the orthorhombic, monoclinic, and triclinic systems as are the pyroxenes, but the orthorhombic varieties are very unimportant and not rock-forming minerals. They differ from the pyroxenes, with which the simpler forms are dimorphous, in that magnesia or its equivalent enters the molecule in greater proportions, — in amphibole, in amounts of three or four to one of calcium, while in pyroxene they are in the proportion of one to one. They all cleave at an angle approximately 124° , while in pyroxenes it is 87° . In crystalline habit they are elongated or fibrous, with the exception of the basaltic hornblende, which occurs usually in equidimensional crystals.

The following table will show the crystalline and optical relations of the various amphiboles.

TREMOLITE

Tremolite. — $CaMg_3(SiO_3)_4$; $CaO = 13.45$, $MgO = 28.83$, $SiO_2 = 57.72$; Monoclinic; Type, Digonal Equatorial; $a : b : c = .5415 : 1 : .2986$; $\beta = 74^\circ 48' = 100 \wedge 001$; $100 \wedge 110 = 27^\circ 54'$; $m \wedge m' = 55^\circ 49'$; $001 \wedge 101 = 24^\circ 4'$; $001 \wedge 011 = 15^\circ 46'$; Common forms, c (001), a (100), b (010), m (110), r (011), t (101); Twinning plane 100, contact twins, also lamellar parallel to the base; Cleavage, prismatic ($124^\circ 30'$), a and b at times distinct; Brittle; Fracture, uneven; H. = 5–6; G. = 2.9–3.4; Color, gray, white, brown, or nearly black, according to composition; Streak, white to gray; Luster, vitreous to pearly; Subtranslucent to opaque. For the optical properties see table, page 432.

B.B. — Like the pyroxenes in every respect, from which they must be distinguished by their physical and optical properties.

General Description. — Crystals are elongated or fibrous parallel to the vertical axis. In basaltic hornblende the habit is short

and stout combinations of *m*, *b*, *r*, and *t*; the pinacoid *a* is never well developed. On the surface these crystals appear as if corroded, caused probably by magmatic resorption. The character-

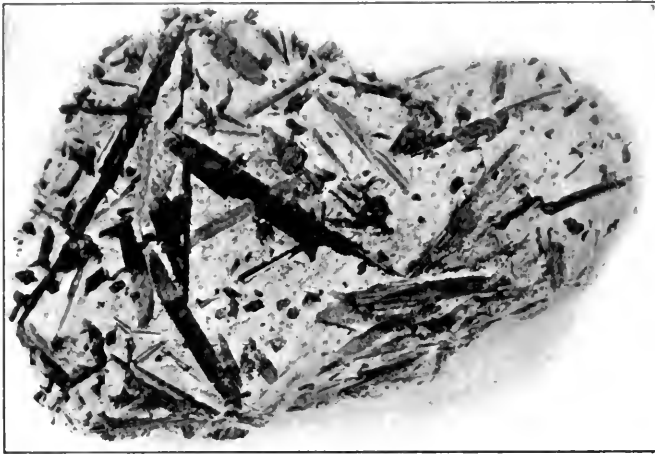

FIG. 476. — Actinolite in Talc, from the Tyrol.

istic cleavage of approximately 124° serves to distinguish them from the pyroxenes. Color varies greatly with the composition, being white or gray in tremolite, where there is little or no iron; green in actinolite; black or dark brown in the basaltic hornblende; and

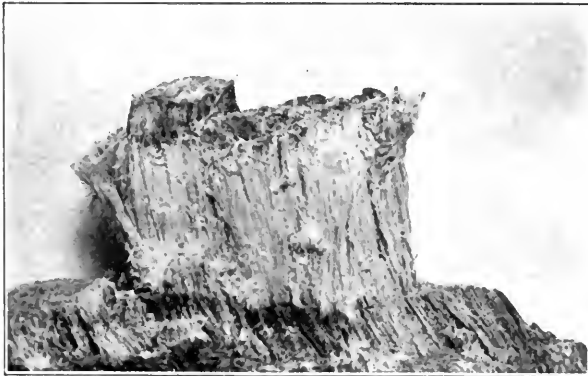

FIG. 477. — Fibrous Amphibole: Var. Asbestos from the Tyrol.

pink in hexagonite, a manganese variety. The soft, fibrous variety is asbestos and differs from the serpentine variety of asbestos, as it contains no water. In sections it is irregular, granular, or

rhombic in outline. Tremolite is colorless; actinolite, light green; hornblende, olive to brown. All varieties show the characteristic prismatic cleavage of $124^{\circ} 30'$ when cut perpendicular to the vertical axis. The relief is distinct and the surface is rough, especially in the dark-colored varieties. Pleochroism is very characteristic and increases with the depth of color, absorption being the stronger parallel to the cleavage. Interference colors are higher, second order, or very high in case of some of the basaltic forms. Extinction varies from 0° to 20° with the percentage of iron present, though not regularly, being higher in the darker varieties. The plane of the optic axes is in the plane of symmetry with the acute bisectrix in the small angle β , Fig. 347, page 199.

Interference figures are well defined, an optic axis emerging in the basal and orthopinacoidal sections. Distinguished from

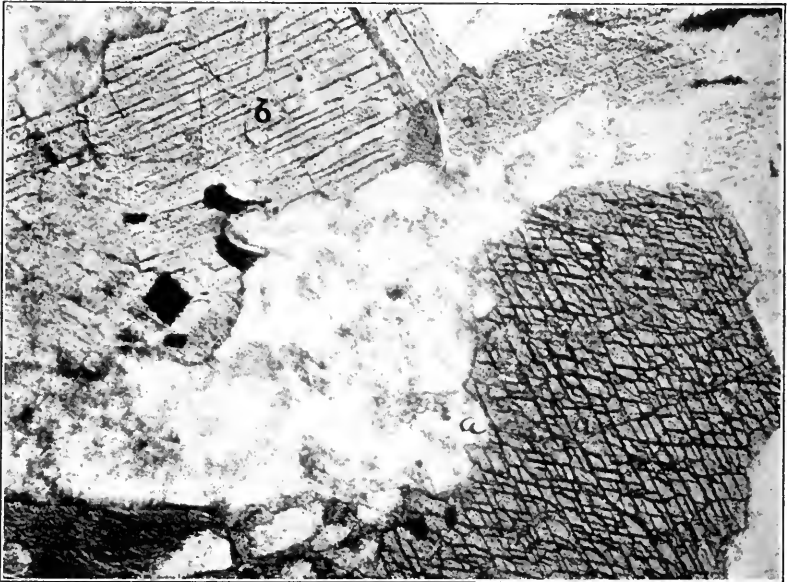

FIG. 478.—Section of Diorite, showing the Relief and Cleavage Angle, 124° , of Hornblende *a*, and also the Parallel Cleavage *b*, when cut Parallel to the Vertical Axis.

pyroxenes by the cleavage; by the strong pleochroism; smaller angle of extinction; lower interference colors and somewhat lower relief.

The amphiboles are important rock-forming minerals widely distributed in igneous and metamorphic rocks. Tremolite and ac-

tinolite are found in schists and granular limestones and are associated with metamorphism only, while hornblende occurs both as a primary mineral in granites, syenites, diorites, and gabbros, as well as in the gneisses and schists. The dark basaltic hornblendes are igneous only, and form phenocrysts in ferruginous lavas, basalts, and gabbros, as at Aussig in Bohemia, or Monte Somma, Vesuvius. The soda-iron varieties, barkevikite, riebeckite, arfved-

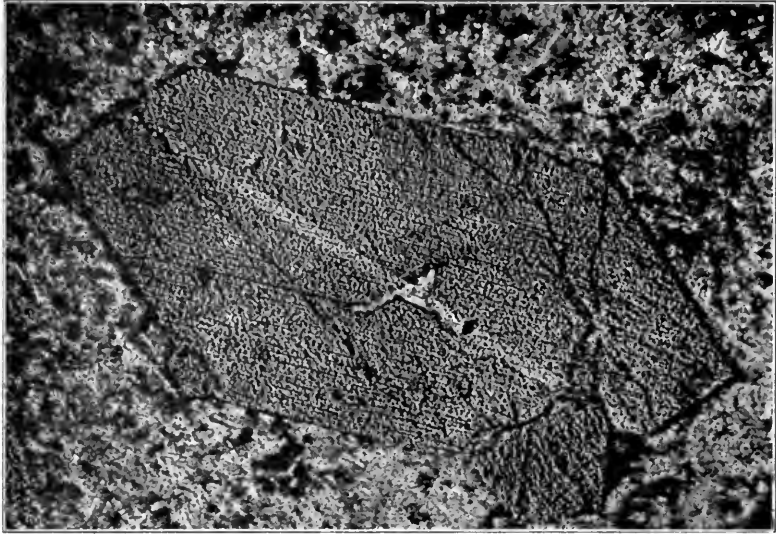

FIG. 479. — Hornblende-diorite-porphry, showing Section of a Hornblende Crystal.

sonite and ænigmatite, occur only in those igneous rocks rich in alkali, as the nephelite-syenites of Greenland and Norway. Arfvedsonite is found near Magnet Cove, Arkansas. Crocidolite is a fibrous soda-iron variety of varied colors, occurring near the Orange River, South Africa; it occurs included in quartz, making a very pleasing ornamental stone; when polished and mounted in jewelry it is the semiprecious "tiger-eye."

The decomposition products of the calcium and magnesium varieties are talc, serpentine, and calcite, while those containing iron in addition form hematite, limonite, or siderite, as well as chlorite, epidote, and augite. Uralite is a fibrous pseudomorph of hornblende after augite, having the crystalline form of augite but the cleavage of hornblende; under suitable conditions this process of uralitization may be reversed, and hornblende will pass over to augite.

In the formation of amphiboles the rate of cooling, the presence of an excess of magnesium over calcium, as well as the presence of water and pressure, all have an influence in determining whether an amphibole or pyroxene will form. Amphibole is the less stable form of the two, as when fused and cooled a pyroxene will be formed, it being impossible to form amphiboles by a simple fusion in an open crucible.

The amphiboles artificially are produced with difficulty and only by long-continued heating of their constituents, with water and under pressure. The magnesium metasilicate with optical properties of an amphibole has been formed by simple fusion.

BERYL

Beryl. — Beryllium aluminium metasilicate, $\text{Be}_3\text{Al}_2(\text{SiO}_3)_6$; $\text{BeO} = 14.11$, $\text{Al}_2\text{O}_3 = 19.05$, $\text{SiO}_2 = 66.84$; Hexagonal; Type, Dihexagonal Equatorial; $\epsilon = .4989$; $0001 \wedge 10\bar{1}1 = 29^\circ 57'$; $0001 \wedge 20\bar{2}1 = 49^\circ 2'$; Common forms, $c(0001)$, $m(10\bar{1}0)$, $r(10\bar{1}1)$, $u(20\bar{2}1)$; Twinning not observed; Cleavage, basal imperfect; Brittle; Fracture, conchoidal; $H. = 7.5-8$; $G. = 2.63-2.80$; Color, shades of green, yellow, white, or lilac; Streak, white; Luster, vitreous; Transparent to subtranslucent; $\omega = 1.584$; $\epsilon = 1.578$; $\omega - \epsilon = .006$; Optically (-).

B.B. — Whitens and fuses with difficulty, only on the thinnest edges. When containing alkalis, it may fuse easier. Insoluble in acids.

General description. — Crystals are stout prismatic in habit, usually combinations of the hexagonal prism and pyramid of the first order and the base, often striated or furrowed lengthwise. Various other pyramids and complex combinations have been described from Alexander County, North Carolina. Hexagonal prisms of enormous size, weighing hundreds of pounds, occur at Grafton and Acworth, New Hampshire. It is also common in the pegmatites of Maine, at Albany, Norway, Bethel, and Paris, usually associated with tourmaline, spodumene, and lepidolite.

The clear green variety is the gem emerald, but owing to the prevalence of cavities it is very difficult to obtain an emerald that is flawless. The emeralds of commerce are in large part mined at Muzo, United States of Colombia, where they are found in a crystalline limestone and slates. Fine emeralds are also obtained from

Brazil; from the Ural Mountains in Siberia, where they are associated with topaz and quartz; from the Tyrol, imbedded in a chloritic schist; from North Carolina, where they are associated with the green spodumene, hiddenite.

Aquamarine, the clear blue-green variety, is more common and less valuable than the emerald. A pink or lilac-colored beryl, morganite, found in a pegmatite of Madagascar and at Pala,



FIG. 480.—Beryl. The Simple Crystal is from Albany, Maine, the Other from Middletown, Connecticut.

California, where it is associated with spodumene of the same color, tourmaline, and lepidolite, is also used as gem material.

The various colors of beryl are caused by the replacement of beryllium in part by the alkalis potassium, caesium, lithium, and sodium; the aluminium may at the same time be replaced by chromium, which yields the green and bluish colors.

Beryl is a common mineral of the pegmatites, where it is associated with tourmaline, topaz, spodumene, corundum, micas, feldspars, and garnets. In the Black Hills, South Dakota, it is associated with cassiterite. As a product of metamorphosis it occurs in the crystalline limestones, chloritic schists, and slates.

In weathering the beryllium is carried away in solution to form secondary minerals, while the aluminium and silica form kaolin,

and with the addition of alkali and water form micas. Artificial beryl has been formed by fusing the constituent oxides with boric acid.

ORTHOSILICATES

SODALITE GROUP

	COMPOSITION	GRAVITY	INDEX OF REFRACTION
Sodalite	$\text{Na}_4(\text{AlCl})\text{Al}_2(\text{SiO}_4)_3$	2.14–2.30	1.4827
Häüynite	$(\text{Na}_2 \cdot \text{Ca})_2(\text{NaSO}_4\text{Al})\text{Al}_2(\text{SiO}_4)_3$	2.4–2.5	1.496
Noselite	$\text{Na}_4(\text{NaSO}_4\text{Al})\text{Al}_2(\text{SiO}_4)_3$	2.25–2.4	
Lazurite	$\text{Na}_4(\text{NaS}_3 \cdot \text{Al})\text{Al}_2(\text{SiO}_4)_3$	2.38–2.45	

The four species included in this group are all alkali aluminium orthosilicates containing either chlorine or sulphur. They are all isometric in symmetry, have a low specific gravity and a hardness of 5.5–6, and a vitreous or greasy luster; Crystal forms are the cube, rhombic dodecahedron, and octahedron, but generally massive or granular; Cleavage, dodecahedral; Brittle; Fracture, conchoidal to uneven. Color, white, gray, yellow, blue, green, or brown; Streak, white or pale blue. Index of refraction very low. All isotropic, häüynite may in cases show a weak double refraction.

B.B. — Fuse at 3.5 to 4.5. All gelatinize with HCl; the solution freed of silica and slowly evaporated will yield cubic crystals of salt (NaCl). Lazurite when dissolved in HCl yields hydrogen sulphide and usually glows with a blue flame when first heated in the O. F.

When häüynite is dissolved in HCl, the solution freed of silica, and the Al precipitated with ammonia and filtered out, the filtrate will yield a white precipitate with ammonium carbonate (Ca); the other three members of the group containing no calcium will not yield a precipitate. Noselite is distinguished from sodalite by yielding a sulphur reaction when fused with soda and a little coal dust, then placed on silver.

General description. — These four minerals are associated in nature and occur as constituents of those lavas low in silica and high in their alkali content, where nepheline and leucite are their companions. Häüynite and noselite are found in the lavas of recent geological date and are very rare in the coarsely crystalline elæolite syenites, here sodalite alone of the group occurs. Lazurite occurs in crystalline limestone and is a product of contact metamorphism.

In their crystallization from the magma they usually follow the pyroxenes, forming the ground mass in which the crystals and minerals previously crystallized are embedded, as is often the case with the feldspars; from this relation they are termed the feldspathoids.

In sections when well formed they are square or six-sided in outline, otherwise rounded and irregular, colorless, greenish to blue.

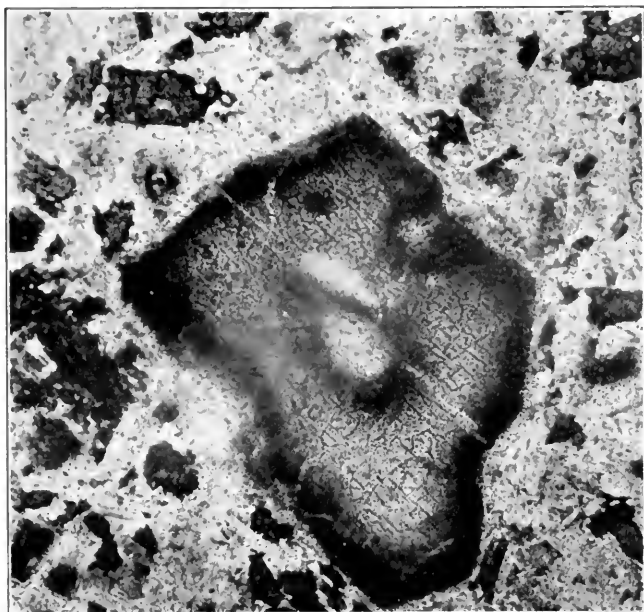

FIG. 481.—Section of Häüynite, showing the Dark, Dust-like Inclusions collected near the Margin.

The relief is slightly rough. Inclusions in sodalite are rare, but fine particles of glass and cavities filled with gas are characteristic of häüynite. They are often collected at the center, or marginal or in concentric bands in the crystal section. The feldspathoids are easily decomposed; the first step is hydration, forming zeolites; numerous pseudomorphs of natrolite after sodalite occur. When alteration is pushed still further muscovite and kaolin are formed.

Lazurite is used as an ornamental stone and in inexpensive jewelry, as lapis lazuli. It is particularly prized in Russia for tables, vases, and in the decoration of altars in the churches. It is mined at Badakshan in Siberia. A fine quality also comes from Persia. The pigment ultramarine was formerly the natural mineral

ground to a powder, but has been displaced by the much cheaper artificial product, formed by the fusion of kaolin, sodium carbonate, and sulphur at comparatively a low temperature, below 700° , as these minerals decompose or are unstable above that temperature.

IOLITE

Iolite. — Cordierite; Dichroite; $H_2(Mg.Fe)_4Al_8Si_{10}O_{37}$; $MgO = 10.2$, $FeO = 5.3$, $Al_2O_3 = 33.6$, $SiO_2 = 49.4$, $H_2O = 1.5$; Orthorhombic; Type, Didigonal Equatorial; $\bar{a} : \bar{b} : \bar{c} = .5871 : 1 : .5585$; $100 \wedge 110 = 30^{\circ} 25'$; $001 \wedge 101 = 43^{\circ} 34'$; $001 \wedge 011 = 29^{\circ} 11'$; Common forms, **c** (001), **a** (100), **b** (010), **m** (110), **d** (130), **s** (112); Twinning plane **m** forming pseudo-hexagonal shapes; Cleavage, brachypinacoidal distinct, **a** and **c** less so; Brittle; Fracture, conchoidal; $H. = 7-7.5$; $G. = 2.6-2.66$; Color, shades of blue or smoky; Streak, white; Transparent to translucent; Pleochroism very strong, **a** bluish, **b** yellow, **c** blue; $\alpha = 1.532$; $\beta = 1.536$; $\gamma = 1.539$; $\gamma - \alpha = .007$; Optically (-); Axial plane = 100; $Bx_a = c$; $2V = 39^{\circ} 32'$ but variable.

B.B. — Becomes opaque, and fuses with difficulty at 5.5. The powdered mineral heated very hot in the closed tube yields water. Partially decomposed in acids.

General description. — Crystals are short prismatic in habit, pseudo-hexagonal from twinning; more often it occurs granular or massive. Iolite occurs as a constituent of igneous rocks, but is more characteristic of schists, gneisses, and contact metamorphosis, where it is associated with tourmaline, biotite, garnets, sillimanite, quartz, and the plagioclases. It is widely distributed in the gneisses of Connecticut, Massachusetts, and New Hampshire. In sections it appears very much like quartz, but is slightly pleochroic in thin sections and is biaxial. The variety cerasite from Japan has a large number of inclusions symmetrically arranged, as in andalusite or chialtolite. It decomposes easily, forming by hydration a series of compounds, as fahlunite, praseolite, gigantolite, and with the addition of iron and alkalies, pinite or mica is formed.

NEPHELITE

Nephelite. — Nepheline; Elæolite, $(Na.K)AlSiO_4$, usually written $K_2Na_6Al_3Si_9O_{34}$; $K_2O = 7.7$, $Na_2O = 15.1$, $Al_2O_3 = 33.3$, $SiO_2 = 44$; Hexagonal; Type, Hexagonal Alternating; $\bar{c} = .8389$; $0001 \wedge 10\bar{1}1 = 44^{\circ} 5'$; Crystal forms, **c** (0001),

m (10 $\bar{1}0$), p (10 $\bar{1}1$), a (1120 $\bar{0}$); Cleavage, prismatic and basal distinct; Brittle; Fracture, subconchoidal; $H.$ = 5.5-6; $G.$ = 2.55-2.65; Color, white, yellow, green, blue, brown, or red; Streak, colorless or pale; Luster, vitreous to greasy; Transparent to opaque; ω = 1.5416; ϵ = 1.5376; $\omega - \epsilon$ = .004; Optically (-).

B.B. — Fuses quietly at 3.5 (1100°), yielding a yellow flame (sodium). Gelatinizes with HCl; the solution freed of silica yields a precipitate of aluminium hydroxide with ammonia.

General description. — Crystals when developed are short, stout, hexagonal prisms terminated by the base or tabular parallel to the base. Several pyramids of both the first and second orders have been described on small crystals from the lavas of Monte Somma, Vesuvius.

Elæolite is the more common granular or massive form of nepheline, of the older syenites, in which it occurs at times as the dominant mineral.

Chemically nepheline is probably a mixture of sodium aluminium orthosilicate (NaAlSiO₄), which has been produced artificially,

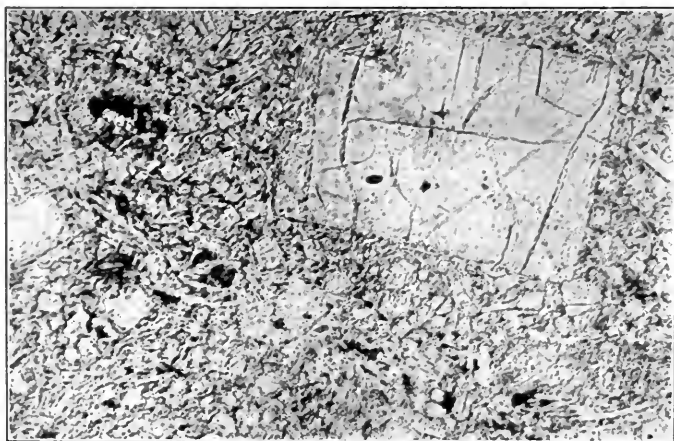

FIG. 482. — Nepheline in a Section of Phonolite. The Small Square Crystals are also Nepheline. The Elongated Crystals are Feldspar.

but is not known as a mineral, and potassium aluminium orthosilicate (KAlSiO₄), which is the mineral kaliophyllite, with possibly a little excess SiO₂ in its molecule. Eucriptite is the lithium salt (LiAlSiO₄), while cancrinite, H₆N₁₆Ca(NaCO₃)₂Al₃(SiO₄)₃, is a min-

eral very similar in physical and crystalline properties, as well as associations, but contains carbonates in its composition.

In sections, nepheline when crystalline is either square or hexagonal in outline, colorless, with no relief; cleavage is not marked except when decomposition has begun. Inclusions are not characteristic except that in some occurrences it may be filled with dust-like inclusions of glass and gas bubbles, in concentric bands or zonal. Interference color very low grays of the first order, and extinction parallel to the cleavage or symmetrical.

Nepheline is a primary mineral of many igneous rocks, especially those rich in alkalis and low in silica. It seems to form in those magmas in which the sodium is in excess of that required to produce feldspars, separating from the magma in most cases just before the feldspars and directly after the sodalite group, with which it is frequently associated, as in the lavas of Vesuvius. At Litchfield, Connecticut, it is associated with cancrinite in an elæolite syenite. In syenites the massive elæolite is characteristic, lending its name to the group, elæolite syenites.

In weathering, zeolites, especially natrolite, result; but the formation of sodalite by the addition of chlorine may be the first step in this reaction.

Artificially nephelinite has been produced by a fusion of its constituent oxides at a low temperature, from which crystals easily separate.

GARNETS

Garnets are orthosilicates of the general formula $R''_3R'''_2(\text{SiO}_4)_3$, in which R'' may be Ca, Mg, Fe'' , Mn, and $R''' = \text{Al}, \text{Fe}''', \text{Cr}$; Isometric; Type, Ditesseral Central; Common forms, *d* (110), *n* (211), *s* (321); Twins rare; Cleavage, dodecahedral sometimes distinct; Brittle; Fracture, conchoidal; H. = 6.5–7; G. = 3.15–4.3; Color, all colors; Streak, white or pale; Transparent to opaque; Luster, vitreous to resinous; *n* = 1.7–1.8.

B.B. — Fuses at three, except uvarovite which fuses at six. After fusion gelatinizes with HCl, otherwise not much affected by acids. Those containing much iron become magnetic after fusion in O. F.

General description. — Crystals are common and in some instances very large, up to a foot in diameter; in habit either rhombic dodecahedrons or tetragonal trisoctahedrons or combina-

tions of these two forms. Other forms are rare; the cube occurs on crystals from Mill Rock, New Haven, Conn., and the octahedron on crystals from the isle of Elba.

Striations appear on the dodecahedral face parallel to the long diagonal, and on the trisoctahedral face parallel to its intersection

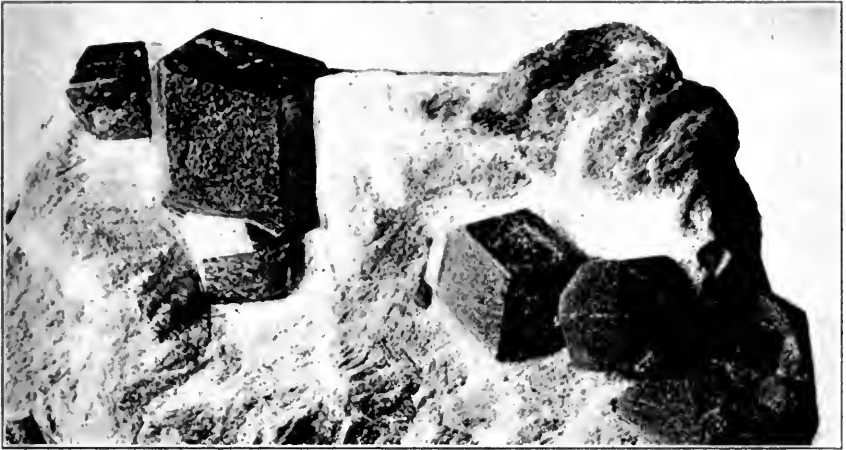

FIG. 483. — Garnet Crystals in Schist. Southbury, Connecticut.

with the rhombic dodecahedrons; these striations appear on the weathered or water-worn crystals also.

The garnets form a very compact isomorphous group in which there is a gradual transition from one variety to the other. They are as a rule grouped under six heads, with varieties under each of these.

I. Grossularite, Calcium aluminium garnet, $\text{Ca}_3\text{Al}_2(\text{SiO}_4)_3$; $\text{CaO} = 37.30$, $\text{Al}_2\text{O}_3 = 22.69$, $\text{SiO}_2 = 40.01$; H. = 6.5; G. = 3.5; Color, white, amber yellow to cinnamon brown, sometimes green when chromium is present. Cinnamon stone, or hessonite, is a brown variety, beautiful specimens of which are obtained from Ala, Piedmont; also Ceylon; and Bethel and Rumford, Maine; Amity, New York, and many other localities, as it is a common variety of garnet.

II. Pyrope; Magnesium aluminium garnet, $\text{Mg}_3\text{Al}_2(\text{SiO}_4)_3$; $\text{MgO} = 29.82$, $\text{Al}_2\text{O}_3 = 25.40$, $\text{SiO}_2 = 44.78$; H. = 7.5; G. = 3.7; Color, dark red to nearly black.

This is the precious garnet of the jewelers, often called the "Cape Ruby." Good pyropes are associated with serpentine at

Bilin, Bohemia; pyrope is found in the "Blue Ground" with the diamond in South Africa; in New Mexico on the Navajo Reservation, where it is associated with chrysolite.

III. Almandite; Common Garnet; Iron aluminium garnet, $\text{Fe}_3\text{Al}_2(\text{SiO}_4)_3$; $\text{FeO} = 43.34$, $\text{Al}_2\text{O}_3 = 20.34$, $\text{SiO}_2 = 36.15$; but

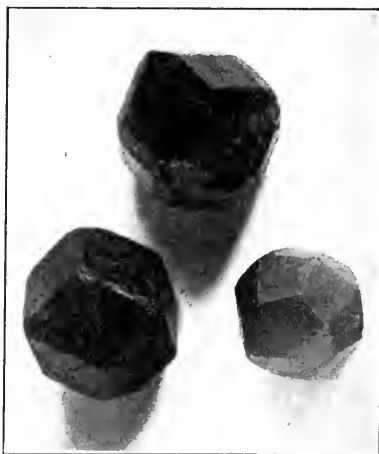

FIG. 484. — Garnet.

composition variable; Color, red to black; Transparent to opaque. The clear red specimens are the "carbuncle," used as a precious garnet. Large crystals of this garnet are of common occurrence, as at Salida, Colorado; Fort Wrangle, Alaska, where symmetrical combinations of the dodecahedron and the tetragonal trisoctahedrons are obtained. Dodecahedrons of an inch in diameter are found in a schist at Southbury, Connecticut. Crystals three or four inches in diameter occur

at Arendal, and somewhat smaller specimens at Bodo, Norway. All the well-developed and large crystals are in a mica schist.

IV. Spessartite; Manganese aluminium garnet, $\text{Mn}_3\text{Al}_2(\text{SiO}_4)_3$; $\text{MnO} = 42.95$, $\text{Al}_2\text{O}_3 = 20.73$, $\text{SiO}_2 = 36.30$; $\text{H.} = 6.5$; $\text{G.} = 3.8$; Color, dark hyacinth-red to brown-red. Beautiful specimens of this garnet are found at Amelia Court House, Virginia; also at Salem, North Carolina; Haddam, Connecticut; and Bethel, Maine.

V. Andradite; Calcium iron garnet, $\text{Ca}_3\text{Fe}_2(\text{SiO}_4)_3$; $\text{CaO} = 33.06$, $\text{Fe}_2\text{O}_3 = 31.49$, $\text{SiO}_2 = 35.45$; in the black melanite and schorlomite some of the silica may be replaced by titanium; $\text{H.} = 6.5$; $\text{G.} = 3.8$; Color, various shades of green and yellow to black. Demantoid is a massive green variety often polished as an ornamental stone. Aplome is also a green variety found at Schwarzenberg, Saxony. Topazolite is greenish yellow and found at Ala in Piedmont. Polyadelphite is a brown variety found in large crystals and massive at Franklin, New Jersey; it contains considerable manganese. Black varieties are also found at Franklin, while the titaniferous garnets occur at Magnet Cove, Arkansas; and at Henderson, North Carolina.

VI. Uvarovite: Calcium chrome garnet, $\text{Ca}_3\text{Cr}_2(\text{SiO}_4)$; $\text{CaO} = 29.27$, $\text{Cr}_2\text{O}_3 = 32.50$, $\text{SiO}_2 = 38.23$; $\text{H.} = 7$; $\text{G.} = 3.4$; Color, bright green. Fuses with difficulty and will not gelatinize after fusion. This garnet is usually associated with chromite and with serpentine; at Oxford, Canada, however, it is found in the cavities of a granular limestone. It occurs at Wood's chrome mine, Lancaster, Pennsylvania; at New Idria, California.

In rock sections garnet appears in crystalline outline, granular or irregular, colorless or in pale colors, with a high relief and a rough surface and parting at times distinct. A zonal structure

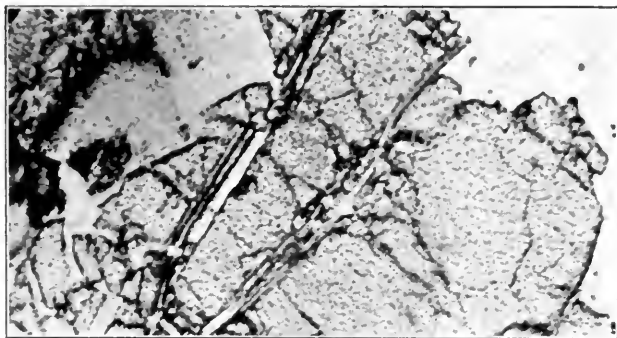

FIG. 485.—Section of Garnet, showing the High Relief and Parting.

is often noticed, especially in the titaniferous varieties. Isotropic, but may exhibit anomalous weak double refraction, which is very often a characteristic of the garnets of contact zones.

Occurrence.—Garnets occur as accessory minerals in rocks of all varieties, the kind depending upon the nature of the magma. Andradite and almandite are found in granites; pyrope is connected with peridotites and serpentine; spessartite is found in quartzite and rhyolite; grossularite is the common garnet of crystalline limestone; while all may be found in crystalline schists and gneisses, as well as in metamorphic and contact zones. Eclogite is a rock composed almost entirely of massive garnet.

Garnet is easily decomposed by weathering, and forms chlorite, iron ores, calcite, kaolinite, epidote, and a large number of secondary minerals, depending upon the chemical composition of the original garnet. Garnets when fused break down, and the melt on cooling forms other silicates, as anorthite, pyroxenes, or scapolite. They are therefore unstable at the temperature of fusion. Some garnets have been formed, as spessartite, by a simple fusion

of the constituent oxides; but as a rule some flux, as calcium chloride, must be added to lower the fusing point to a temperature at which the formation of garnets is possible.

OLIVINE GROUP

The olivine group is composed of isomorphous orthosilicates of the general formula $R''_2\text{SiO}_4$, in which R'' is Ca, Mg, Fe'' , Mn, Zn, or mixtures of these metals; they are of orthorhombic symmetry and members of the didigonal equatorial type, crystallizing usually in combinations of the three pinacoids with the unit pyramid and a dome, or pyramidal in habit; at times tabular, parallel to \mathbf{b} more often than to \mathbf{a} . They have two well-developed cleavages at a right angle.

The following table will serve to show their relations both optically and chemically.

OLIVINE

Olivine. — Chrysolite; Magnesium iron orthosilicate; MgFe-SiO_4 ; $\text{MgO} = 49.19$, $\text{FeO} = 10.54$, $\text{SiO}_2 = 39.85$; $\check{\mathbf{a}} : \bar{\mathbf{b}} : \check{\mathbf{c}} = .4656 : 1 : .5865$; $110 \wedge 100 = 24^\circ 58'$; $001 \wedge 101 = 51^\circ 33'$; $001 \wedge 011 = 30^\circ 24'$; Common forms, \mathbf{a} (100), \mathbf{b} (010); \mathbf{c} (001), \mathbf{m} (110). \mathbf{s} (120), \mathbf{d} (101), \mathbf{e} (111), \mathbf{k} (021); Twinning plane, 011 rare; Cleavage, \mathbf{b} distinct, \mathbf{a} less so; $\mathbf{H.} = 6.5-7$; $\mathbf{G.} = 3.27-3.37$; Color, shades of green to red or brown; Streak, white or pale; Luster, vitreous; Transparent to opaque; $\alpha = 1.653$; $\beta = 1.670$; $\gamma = 1.689$; $\gamma - \alpha = .036$; Optically (\pm); Axial plane = 001; $\mathbf{Bx}_a = \check{\mathbf{a}}$ or $\bar{\mathbf{b}}$; $2V = 86^\circ 89'$.

B.B. — Dark-colored specimens fuse to a magnetic slag, while the light-colored specimens whiten and fuse with difficulty. Gelatinizes with HCl. With the fluxes reacts for iron.

General description. — Crystals are usually small and nearly equidimensional or tabular, parallel to \mathbf{a} or \mathbf{b} ; more often granular, friable masses, in which form it is often found in large rock areas, as the dunites of Georgia, North and South Carolinas, where it is associated with corundum. Chrysolite and peridot are names often applied to olivine, but more particularly to the clear transparent varieties, which are used as gem stones. Peridot is leaf-green in color, and for a long time was gathered along the shore of the Red Sea, where the water-worn pebbles were thrown up by

TABLE OF THE OLIVINE GROUP

SPECIES	COMPOSITION	SPECIFIC GRAVITY	a : b : c	INDICES OF REFRACTION	OPT. CHAR.	2 V _γ	Bxa	PL. OPT. AXES
Monticellite . . .	CaMgSiO ₄	3.11	.4337 : 1 : .5758	$\gamma - \alpha$ $\left\{ \begin{array}{l} \alpha = 1.650 \\ \beta = 1.662 \\ \gamma = 1.668 \end{array} \right\}$	-	37°0	b	(001)
Forsterite . . .	Mg ₂ SiO ₄	3.25	.4666 : 1 : .5868	$\left\{ \begin{array}{l} \beta = 1.659 \end{array} \right\}$	+	86°	\bar{a}	(001)
Glaucochroite . . .	CaMnSiO ₄	.4400 : 1 : .5660		High			\bar{a}	
Olivine	(MgFe) ₂ SiO ₄	3.35	.4656 : 1 : .5865	$\left\{ \begin{array}{l} \alpha = 1.653 \\ \beta = 1.670 \\ \gamma = 1.689 \end{array} \right\}$	±	86°-89°	FeO > 12% \bar{b}	(001)
Hortonolite	(FeMgMn) ₂ SiO ₄	3.91	.4660 : 1 : .5800	$\left\{ \begin{array}{l} \alpha = 1.768 \\ \beta = 1.791 \\ \gamma = 1.803 \end{array} \right\}$	-	69°	\bar{b}	(001)
Fayalite	Fe ₂ SiO ₄	4.13	.4584 : 1 : .5793	$\left\{ \begin{array}{l} \alpha = 1.824 \\ \beta = 1.864 \\ \gamma = 1.874 \end{array} \right\}$	-	69°	\bar{b}	(001)
Knebelite	(MnFe) ₂ SiO ₄	4.12	.4621 : 1 :		-	63°45'	\bar{b}	(001)
Tephroite	Mn ₂ SiO ₄	4.12	.4600 : 1 : .5939		-	76°6	\bar{b}	(001)
Roeppeite	(FeMnZn) ₂ SiO ₄	4.00					\bar{b}	(001)

the waves after storms. It was also obtained from the Arabs of Egypt, but the exact locality from whence it was gotten is unknown. Gem material is found near Fort Defiance, Arizona.

Chrysolite is a yellow variety resembling very much the yellow topaz when cut and polished.

Olivine occurs as an essential constituent of many igneous rocks, which are low in silica and rich in the alkali earth metals. Its



FIG. 486.—Olivine Crystals from France.

composition is variable, depending upon the proportion of magnesium, calcium, iron, or manganese, present in the magma. It is found in such rocks as peridotite, gabbros, basalts, nephelites, and leucites, and many lavas, while dunite is almost entirely olivine. It appears less often in andesites and trachytes.

In rock sections it is colorless or pale, with crystalline outline, or more often granular or irregular. The two cleavage directions are well marked, that parallel to b more so than that parallel to a . Extinction parallel. The index of refraction being high, the relief is marked, with all cracks distinct. Interference colors of the second and third order. The plane of the optic axes is parallel to 001 and the optical character is plus, with the acute bisectrix \check{a} , when the ferrous oxide is below 12 per cent.; when above 12 per cent., the acute bisectrix is \bar{b} and the optical character is minus. Inclusions are not characteristic, but spinel, chromite, apatite, and hypersthene appear; also glass and slag in the lava occurrences. Pleochroism is marked only when the iron content is high.

In its alteration olivine readily forms serpentine, the alteration following the fractures or cleavage cracks in the crystal, with the serpentine fibers lying crosswise. The iron at the same time separates as oxide and is deposited along the cracks, or where the specimen is rich in iron as layers interlaminated with the serpentine; carbonates, as magnesite and calcite, and also opal, quartz,

and brucite may appear as alteration products. Chromite is almost always associated with the alteration of peridotite or with the serpentine resulting from it, as at the Maryland locality.



FIG. 487.—Section of Olivine, showing the Cracks filled with Secondary Magnetite and a Marginal Band of Enstatite and Hornblende.

Some nickel deposits, as the garnierite of New Caledonia, are associated with olivine or its alteration products, as also platinum and the diamonds of South Africa.

Artificially the olivine group is easily synthesized by a direct fusion of their constituents in the right proportion, particularly if a little boric acid is added to lower the fusing point. They are therefore common products of slags and are also found in meteors. When olivine is fused with a little silica in excess, enstatite is formed; if the silica is increased, then pyroxenes are formed.

MONTICELLITE

Monticellite. — Calcium magnesium orthosilicate, CaMgSiO_4 ; $\text{CaO} = 35.9$, $\text{MgO} = 25.6$, $\text{SiO}_2 = 38.5$; Orthorhombic; Type, Didigonal Equatorial; $\tilde{a} : \tilde{b} : \tilde{c} = .4337$; $1 : .5758$; $100 \wedge 110 = 23^\circ 27'$; $001 \wedge 101 = 53^\circ$; $001 \wedge 011 = 29^\circ 56'$; Common forms, as in olivine; Cleavage, \tilde{b} distinct; Brittle; Fracture, conchoidal; $H. = 5-5.5$; $G. = 3.03-3.25$; Color, white, gray; Streak, white; Luster, vitreous; Transparent to translucent; $\alpha = 1.650$; $\beta = 1.662$; $\gamma = 1.668$ $\gamma - \alpha = .018$; Optically (-); Axial plane 001 ; $Bx_a = \tilde{b}$; $2V = 37^\circ$.

B.B. — Fuses on the thin edges. Gelatinizes with HCl; this solution freed of silica yields little or no precipitate with ammonia, but a heavy white precipitate with ammonium carbonate.

General description. — In crystalline habit like olivine; also granular and in cleavable masses. It is a product of metamorphism, and as such occurs in ejected blocks of limestone at Monte Somma, Vesuvius. Large crystals nearly an inch in length occur at Magnet Cove, Arkansas. In all other respects it agrees with olivine, though much more restricted in its occurrence.

FORSTERITE

Forsterite. — Magnesium orthosilicate; Mg_2SiO_4 ; $MgO = 57.00$, $SiO_2 = 42.9$; Orthorhombic; Type, Didigonal Equatorial; $\bar{a} : \bar{b} : \bar{c} = .4666 : 1 : .5868$; $100 \wedge 110 = 24^\circ 55'$; $001 \wedge 101 = 51^\circ 34'$; $001 \wedge 011 = 30^\circ 21'$; Common forms as in olivine; Cleavage, **b** distinct, **c** less so; $H. = 6-7$; $G. = 3.21-3.33$; Color, white and light shades of yellow to green; Streak, white; Luster, vitreous; Brittle; Fracture, conchoidal; Transparent to translucent; $\beta = 1.659$; $\gamma - a$ high; Plane of the optic axes = 001; $Bx_a = \bar{a}$; $2V = 86^\circ$.

B.B. — Infusible, gelatinizes with HCl, this solution freed of silica, an excess of ammonia added yields no precipitate with ammonium carbonate (calcium), but yields a white precipitate with ammonium phosphate (magnesium).

General description. — In crystalline habit like olivine, but is largely a product of metamorphism; as such it occurs in the ejected blocks of limestone at Monte Somma, Vesuvius. A variety, Boltonite, occurs as embedded crystals and disseminated grains in a limestone at Bolton, Massachusetts.

FAYALITE

Fayalite. — Ferrous orthosilicate; Fe_2SiO_4 ; $FeO = 70.6$, $SiO_2 = 29.4$; Orthorhombic; Type, Didigonal Equatorial; $\bar{a} : \bar{b} : \bar{c} = .4584 : 1 : .5793$; $100 \wedge 110 = 24^\circ 38'$; $001 \wedge 101 = 51^\circ 39'$; $001 \wedge 011 = 30^\circ 5'$; Forms as in olivine; Cleavage, **b** distinct, **a** less so; Brittle; Fracture uneven; $H. = 6.5$; $G. = 4-4.14$; Color, yellow to nearly black; Streak, pale when unoxidized; Transparent to opaque; $\alpha = 1.824$; $\beta = 1.864$; $\gamma = 1.874$;

$\gamma - \alpha = .050$; Optically (-); Axial plane = 001; $Bx_a = \bar{b}$; $2V = 49^\circ 50'$.

B.B. — Fuses easily in the O. F. and becomes magnetic on coal in R. F. Gelatinizes with HCl.

General description. — Fayalite occurs in small crystals, flattened parallel to the orthopinacoid, in the rhyolites and obsidian of the Yellowstone Park. It has also been identified in a granite at Rockport, Mass. Originally it was described from Fayal Island, Azores.

It is also a common constituent of furnace slags.

It is easily decomposed by weathering, the iron being oxidized to ferric oxide. This takes place along the cracks and on the surface, the crystals becoming dark brown or black and at times iridescent.

Knebelite is a massive mineral containing manganese, or may be considered as a mixture of fayalite and tephroite.

Tephroite is the manganese orthosilicate, Mn_2SiO_4 member of the olivine group. It occurs as a brown or red massive mineral at Franklin, New Jersey, where it is associated with zincite, willemite, and franklinite.

Roepperite is a variety from the same locality containing some zinc.

WILLEMITE

Willemite. — Zinc orthosilicate; Zn_2SiO_4 ; $ZnO = 73$, $SiO_2 = 27$; Hexagonal; Type, Hexagonal Alternating; $c = .6775$; $0001 \wedge 10\bar{1}1 = 38^\circ 2'$; $10\bar{1}1 \wedge \bar{1}011 = 64^\circ 30'$; Common forms, c (0001), a ($11\bar{2}0$), r ($10\bar{1}1$), e ($01\bar{1}2$); Cleavage, basal and prismatic easy; Brittle; Fracture, conchoidal; H. = 5.5; G. = 3.89–4.18; Color, shades of green, yellow, brown, and red; Streak, white or pale; Transparent to translucent; $\omega = 1.6931$; $\epsilon = 1.7118$; $\epsilon - \omega = .0187$; Optically (+).

B.B. — Whitens and fuses with difficulty. On coal in R.F. with soda and a little coal dust yields a zinc coat. Gelatinizes with HCl.

General description. — Crystals are hexagonal, prismatic in habit, terminated by rhombohedrons. It occurs at Franklin, New Jersey, in stout prisms an inch across and several inches in length; these crystals contain manganese, and are red or ash color to dark

brown, known as troostite. In all other localities the crystals are very small, as at Altenberg, Saxony, where the crystals are only a few millimeters in length.

At Franklin it occurs in sufficient quantities to form a valuable ore of zinc, but mostly in cleavable yellow or light green masses, associated with zincite, franklinite, and tephroite. At times it forms long needle-like crystals, apple-green or nearly white in color, or in radiated masses; this last form is rare. The light colored varieties phosphoresce under the influence of magnesium light or the radiations of radium, especially the radiated variety.

Willemite has often been observed in furnace slags, where a lead ore containing zinc is being smelted.

PHENACITE

Phenacite. — Beryllium orthosilicate; Be_2SiO_4 ; $\text{BeO} = 45.55$, $\text{SiO}_2 = 54.45$; Hexagonal; Type, Hexagonal Alternating; $\hat{c} = .6611$; $0001 \wedge 10\bar{1}1 = 37^\circ 21'$; $r \wedge r' = 63^\circ 24'$; Common forms, a ($11\bar{2}0$), m ($10\bar{1}0$), r ($10\bar{1}1$), x ($12\bar{3}2$); Cleavage, a indistinct, r imperfect; Brittle; Fracture, conchoidal; H. = 5-8; G. = 2.97-3; Color, white, pale yellow, brown, or red; Streak, white; Luster, vitreous; Transparent to translucent; $\omega = 1.6542$; $\epsilon = 1.6700$; $\epsilon - \alpha = .0158$; Optically (+).

B.B. — Infusible, with borax in fine powder fuses to a clear glass. With cobalt solution yields a dull blue. Yields reactions for beryllium.

General description. — Crystals are rhombohedral in habit or short prismatic, terminated by rhombohedrons, at times, of all three orders. In its occurrences it is associated with beryl and topaz.

The largest crystals, some nearly four inches across, are obtained near Ekaterinberg in the Urals, Russia. At Pike's Peak it is found implanted on crystals of microcline.

Phenacite when clear and free of flaws is polished as a gem stone.

DIOPTASE

Dioptase. — An acid copper orthosilicate, H_2CuSiO_4 ; $\text{CuO} = 50.4$, $\text{SiO}_2 = 38.2$, $\text{H}_2\text{O} = 11.4$; Hexagonal; Type, Hexagonal Alternating; $\hat{c} = .5341$; $0001 \wedge 1011 = 31^\circ 40'$; $r \wedge r' = 54^\circ 5'$;

Twinning plane $10\bar{1}1 = \text{Common forms, } a (11\bar{2}0), r (10\bar{1}1), s (02\bar{2}1).$
 Cleavage, rhombohedral perfect; Brittle; Fracture, conchoidal;
 H. = 5; G. = 3.28-3.35; Color, emerald green; Streak, pale
 green; Luster, vitreous; Transparent to translucent; $\omega = 1.667$;
 $\epsilon = 1.723$; $\epsilon - \omega = .056$ Optically (+).

B.B. — Infusible, but blackens and decrepitates. Reduced on
 coal with soda and a little coal dust yields metallic copper.
 Gelatinizes with HCl. Yields water in the closed tube.

General description. — Crystals are prismatic in habit, combina-
 tions of the hexagonal prism of the second order, terminated by the
 rhombohedron *s* or several rhombohedrons of the same series.
 The rhombohedron *x* (1231) also appears on some specimens, fix-
 ing the symmetry as hexagonal alternating.

Diopside is a rare mineral, found only in a few localities and then
 in very small amounts. The finest specimens, some of which
 are nearly an inch in length are obtained in a limestone near
 Altyn-Tübe, Siberia. Occurs at Copiapo, Chili, and in the Clifton
 Mine Graham Co., Arizona.

When the crystals are clear and flawless, they are cut and
 polished as a gem.

SCAPOLITE GROUP

The chemical composition is variable, as the scapolite group, like
 the plagioclase feldspars, is formed by two end members, meion-
 ite, $\text{Ca}_4 \text{Al}_6 \text{Si}_6 \text{O}_{25} (\text{me})$ and marialite, $\text{Na}_4 \text{Al}_3 \text{Si}_9 \text{O}_{24} \text{Cl} (\text{ma})$;
 these two species form isomorphous mixtures in all proportions,
 and therefore in composition the series passes uninterruptedly
 from one extreme to the other.

		\bar{c}	ω	ϵ	$\omega - \epsilon$
Meionite	$\text{me} + \text{ma}_0$ to $\text{me}_3 + \text{ma}_1$	0.4393	1.594	1.557	0.037
			1.583	1.554	0.029
Wernerite	$\text{me}_2 + \text{ma}_1$ to $\text{me}_1 + \text{ma}_1$	0.4384	1.570	1.547	0.023
Mizzonite	$\text{me}_1 + \text{ma}_1$ to $\text{me}_1 + \text{ma}_3$	0.4424	1.567	1.550	0.017
Marialite	$\text{me}_1 + \text{ma}_3$ to $\text{me}_0 + \text{ma}$	0.4417	1.562	1.546	0.016
			1.5545	1.5417	0.013

WERNERITE

Wernerite. — Calcium aluminium orthosilicate, $\text{Ca}_4 \text{Al}_6 \text{Si}_6 \text{O}_{25}$;
 CaO = 25.1, $\text{Al}_2 \text{O}_3 = 34.4$, $\text{SiO}_2 = 40.5$; Tetragonal; Type,

Tetragonal Equatorial; $c = .4384$; $001 \wedge 101 = 23^\circ 40'$; Common forms, *a* (100), *c* (001), *m* (110), *e* (101), *h* (210); Cleavage, *a* and *m* distinct; Brittle; Fracture, uneven; *H.* = 5-6; *G.* = 2.66-2.73; Color, white, gray, shades of yellow, green, red, brown to black; Streak, white or pale; Luster, vitreous to pearly; Transparent to opaque; $\omega = 1.562$; $\epsilon = 1.546$; $\omega - \epsilon = .016$; Optically (-).

B.B. — Fuses easily with intumescence to a blebby glass. The fused mass powdered gelatinizes with HCl.

General description. — Crystals coarse prismatic, combination of the two prisms *a* and *m* terminated by the unit pyramid or the two unit pyramids. The third order prism *h* (210) and the pyramid *z* (311) occur on crystals from Grass Lake, New York. Wernerite is often granular or massive.



FIG. 488. — Wernerite. Laucinpaai, Finland.

In sections the scapolites are colorless, either in crystalline outline or rounded grains; prismatic cleavage cracks distinct; relief is very low, about that of quartz. The inclusions are not characteristic; double refraction rather strong, yielding interference colors of the second order and increasing with the amount of calcium present. The interference figure is found in the

sections in which the cleavage cracks are at right angles, yielding a dark cross with color bands in thin sections, in the margin of the field only. Optically negative. The scapolites are found in igneous rocks as secondary minerals only. They are the products especially of contact metamorphism and commonly occur in granular limestones, where they are associated with pyroxene, hornblende, zircon, spinel, titanite, and garnets.

Wernerite occurs in fine crystals at Pierrepont, Gouverneur, Monroe, and Amity, New York, and at numerous points in New Jersey, Pennsylvania and the New England States.

Meionite and mizzonite occur in the ejected blocks of limestone on Monte Somma, Vesuvius.

The scapolites are easily decomposed by weathering, particularly those containing sodium, the ultimate products being kaolin, talc, or micas, with calcite and quartz.

The artificial production of the scapolites is in doubt.

VESUVIANITE

Vesuvianite. — An orthosilicate of calcium and aluminium, $\text{Ca}_6(\text{Al}.\text{OH})\text{Al}_2(\text{SiO}_4)_5$, in which other isomorphous elements may enter; $\text{CaO} = 42.3$, $\text{Al}_2 = 19.1$, $\text{SiO}_2 = 37.5$, $\text{H}_2\text{O} = 1.1$; Tetragonal; Type, Didigonal Equatorial; $\epsilon = .5372$; $001_A 101 = 28^\circ 15'$; $001_A 111 = 37^\circ 14'$; Common forms, *c* (001), *a* (100), *m* (110), *p* (111); Cleavage, prismatic imperfect, *a* and *c* less so; Brittle; Fracture, uneven; *H.* = 6.5; *G.* = 3.35–3.45; Color, shades of brown and green; Streak, white; Translucent; $\omega = 1.705$; $\epsilon = 1.701$; $\omega - \epsilon = .004$; Optically (–), sometimes (+).

B.B. — Fuses with intumescence at three, to a brown slag, which when powdered gelatinizes with HCl. Some varieties will yield reactions for manganese or copper.

General description. — Crystals are well developed, stout prismatic combinations of the prisms of the first and second orders terminated by the base and the unit pyramid. Striations on the prism zone lengthwise. Beautiful crystals, combinations of these forms, are found on the Vilui River, Siberia. Crystals from Wakefield, Quebec, have the pyramid reduced to almost a line and are terminated by the base. Well-formed crystals, combinations of all seven forms of the type, are found at Poland, Maine, and more complicated combinations are found on the crystals from Vesuvius, in some of which the prism zone is very much reduced, yielding crystals of pyramidal habit. Vesuvianite also occurs radiated, columnar, irregular, granular or massive. A compact, green, jade-like variety is known as californite.

Chemically the calcium may be replaced in part by manganese, magnesium, or iron; also fluorine and boron may be present in small amounts. In sections vesuvianite may appear in crystalline outlines, rounded or irregular, colorless or pale. The relief is well marked, with prismatic cleavage cracks imperfectly developed. Pleochroism faint, but increasing with the depth of color of the specimen. Interference colors gray of the first order. Basal sections show only the shadow of the interference figure but no colors. Optically negative, rarely positive.

Zonal structure and optical anomalies are not uncommon.

Vesuvianite is a mineral produced by contact metamorphism. It appears in schists but more often in granular limestones, where

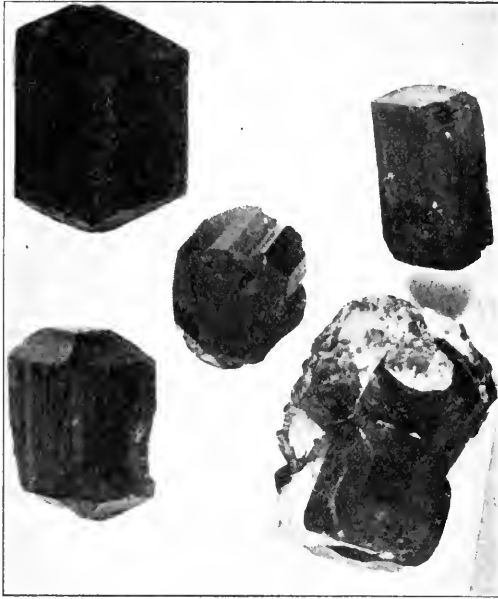

FIG. 489.—Vesuvianite, Poland, Maine. The Upper Crystal is Viluite from Siberia.

it is associated with garnets, epidote, wernerite, wollastonite, and diopside. It is a common mineral in the ejected blocks of limestone on Monte Somma, Vesuvius; in small brilliant crystals also in the Ala thal, Piedmont. Clear green brilliant crystals occur at Amity, New York. It occurs at Rumford and Poland, Maine, in limestones associated with garnets; at Newton, New Jersey, with corundum and spinel.

The clear crystals are sometimes polished, but it makes an indifferent gem known as idocrase.

It is seldom found altered, though pseudomorphs after vesuvianite are known.

Vesuvianite has not been produced artificially; when fused it breaks down and on cooling the melt produces olivine, anorthite, and melilite.

ZIRCON

Zircon.—Zirconium orthosilicate, $ZrSiO_4$; $ZrO_2 = 67.2$; $SiO_2 = 32.8$; Tetragonal; Type, Ditetragonal Equatorial; $c = .6403$; $001 \wedge 101 = 32^\circ 38'$; $110 \wedge 111 = 47^\circ 50'$; $111 \wedge \bar{1}\bar{1}1 = 56^\circ 40'$; Common forms, $p(111)$, $m(110)$, $u(331)$, $x(311)$; Twinning plane 111, geniculate twins; Cleavage, m distinct, p less so; Brittle; Fracture, conchoidal; $H. = 7.5$; $G. = 4.68-4.7$; Color,

pale yellow, brown, red, green, white, and at times nearly black. Streak, white; Transparent to opaque; $\omega = 1.923$; $\epsilon = 1.968$; $\omega - \epsilon = .045$; Optically (+).

B.B. — Whitens but infusible. Only very slightly affected by acids. Yields a zirconium reaction with turmeric paper.

General description. — Crystals are short prismatic combinations of the unit prism and pyramid of the first order. When x is present the crystals are acutely pointed. Microcrystals are more apt to be pyramidal in habit. Twins are not common, but geniculate twins like those found in rutile occur in Renfrew County, Quebec. Zircon is related in its angles and axial ratio to cassiterite and rutile, and these with thorite, ThSiO_4 , constitute an isomorphous group. In rock sections zircon appears either in crystalline outlines or rounded, with a very high relief, and white or pale yellow or brown in color. Cleavage cracks are not marked.



FIG. 490.—Zircon, Buncombe County, North Carolina. The Small Crystal is from Essex County, New York.

Interference colors are high fourth order, and the interference figure shows several colored circles in addition to the dark cross. Optically positive.

Zircon is very widely distributed, occurring as one of the most common accessory minerals of the igneous rocks, as the granites, syenites, and diorites, but never in very large quantities; in such magmas it is the first silicate to separate. It is also of common occurrence in pegmatites, as at Green River, North Carolina, where it is separated in commercial quantities; near Cash, Oklahoma, in a pegmatite. At Greenville, Canada, and Amity, New York, it occurs in a crystalline limestone. At several points in Essex and Orange Counties, New York, deep brown to almost black crystals occur.

It is decomposed by weathering with difficulty and is found in alluvial deposits and gold-bearing sands, with garnets, cassiterite, magnetite, and other heavy minerals, still in a fresh unaltered

condition. At times by hydration it becomes dull and greasy in appearance, forming several varieties, as the malacon from Hitterøe, Norway.

Jargon, jacinth, and hyacinth are clear varieties usually obtained from Ceylon, which are cut and polished as gems.

Artificial zircon may be produced by heating gelatinous silica and zirconia to a red heat under pressure.

TOPAZ

Topaz. — $\text{Al}_2\text{Al}(\text{O},\text{F}_2)\text{SiO}_4$; $\text{Al}_2\text{O}_3 = 55.44$, $\text{SiO}_2 = 32.61$, $F = 20.65$; Orthorhombic; Type, Didigonal Equatorial; $\bar{a} : \bar{b} : \bar{c} = .528$; $1 : .477$; $110_{\wedge}1\bar{1}0 = 55^\circ 43'$; $120_{\wedge}1\bar{2}0 = 86^\circ 49'$; $001_{\wedge}111 = 45^\circ 35'$; $001_{\wedge}223 = 34^\circ 14'$; $001_{\wedge}221 = 63^\circ 54'$; $001_{\wedge}041 = 62^\circ 20'$; $001_{\wedge}043 = 32^\circ 27'$; $001_{\wedge}201 = 61^\circ 30''$; $001_{\wedge}021 = 43^\circ 39'$; Common forms, **a** (100), **b** (010), **c** (001), **m** (110), **l** (120), **d** (201), **f** (021), **y** (041), **x** (043), **o** (221), **u** (111), **i** (223); Cleavage basal perfect; Brittle; Fracture, subconchoidal; $H. = 8$; $G. = 3.4-3.65$; Color, white and pale shades of yellow, pink, blue, green; Streak, white; Transparent to translucent; $\alpha = 1.615$; $\beta = 1.618$; $\gamma = 1.625$; $\gamma - \alpha = .010$; $2V = 62^\circ 33'$; Axial plane = 010; $Bx_a = \bar{c}$; Optically (+).

B.B. — Changes color, but infusible. Yields a fluorine reaction in the closed tube. The powdered mineral becomes blue with cobalt solution. Very little affected by acids.

General description. — Crystals are prismatic in habit, combinations of the two prism, **m** and **l**, both of which are striated lengthwise, but **l** more than **m**; terminated by one or two domes and pyramids, rarely doubly terminated.

In chemical composition the fluorine is variable, as it may be replaced by hydroxyl (OH); both of these are driven off at a white heat, transforming the topaz to sillimanite.

In rock sections topaz appears with crystalline outlines or lath-shaped, elongated parallel to \bar{c} ; the basal cleavage is well marked by cracks. Relief is medium and the interference colors are first order gray or yellow. The interference figure is shown in the basal section; the angle $2E$ varies with the fluorine and decreases as OH increases. For .93 per cent. H_2O , $2E = 114^\circ$. Cavities elongated parallel to the vertical axis and containing fluids are common.

Topaz is an accessory mineral in many granites, and is also

especially characteristic of pegmatites containing cassiterite, in which it is also associated with beryl, tourmaline, fluorite, and apatite. At Schneckenstein, Saxony, it is associated with apatite chalcopyrite, and cassiterite.

The large blue crystals from Mursinka, in the Urals, are associated with smoky quartz, lepidolite, and feldspars. At Nathrop, Colorado, and in the Thomas Range, Utah, well-developed crystals, both white and wine-colored, are associated with quartz, in cavities in rhyolite.

At Stoneham, Maine, it occurs in granite. The topazes of Minas Geraes, Brazil, occur in a decomposed schist; they are a light brown color with numerous elongated cavities, containing liquid carbon dioxide.

Topaz, owing to its hardness, transparency, and delicate coloring, has for a long time been used as a precious stone, especially those from Siberia and Brazil. The Brazilian topazes may be improved in color and the yellow and brown shades changed to a delicate pink by careful heating; this process is known as pinking.

In the process of weathering, topaz takes up water and alkalis, forming micas.

The synthesis of topaz has been accomplished by heating a mixture of silica and aluminium fluoride to a red heat and then igniting the mixture in a current of silicon fluoride. Both the synthesis and the associations indicate that in many cases topaz has been the result of pneumatolytic reactions in which volatile fluorides were the direct agent.

ANDALUSITE

Andalusite. — $\text{Al}(\text{AlO})\text{SiO}_4$; $\text{Al}_2\text{O}_3 = 63$, $\text{SiO}_2 = 37$; Orthorhombic; Type, Didigonal Equatorial; $\tilde{a} : \tilde{b} : \tilde{c} = .986 : 1 : .702$; $100_{\tilde{a}}110 = 44^\circ 36'$; $001_{\tilde{a}}011 = 35^\circ 5'$; Common forms, c (001), m (110), s (011); Cleavage, prismatic distinct, a less so; Brittle; Fracture, uneven; $H. = 7.5$; $G. = 3.16-3.20$; Color, gray, reddish, pink, blue, and green; Streak, white; Luster, vitreous; Transparent to opaque; $\alpha = 1.632$; $\beta = 1.638$; $\gamma = 1.643$; $\gamma - \alpha = .011$; Optically (-); $Bx_a = \tilde{c}$; $2V = 83^\circ 37'$.

B.B. — Infusible, not attacked by acids. The fine powder becomes blue with cobalt solution.

General description. — Crystals are coarse, prismatic, simple combinations of the nearly square unit prism and the base or dome;

such combinations are found at Lisens Alp, Tyrol, embedded in a chloritic schist. Transparent crystals which display very strong



FIG. 491.—Andalusite from Lancaster, Massachusetts.

dichroism are obtained in Minas Geraes, Brazil, and are cut as gem stones showing green when viewed along one direction and red when viewed in the other.

Many specimens of andalusite contain organic inclusions arranged symmetrically, the outline or cross section of which varies with the position in the crystal. Like the symmetrical inclusions in leucite, this arrangement is prob-

ably due to a skeletal development during the growth of the crystal; such inclusions are especially characteristic of the variety known as chiasmolite, found in argillaceous schists and clay slates, the crystals of which are slender, prismatic, almost acicular.

Andalusite is trimorphic with sillimanite and cyanite, all being of the same percentage composition chemically, but differing in their physical and crystallographical properties. Of the three, sillimanite is the most stable at high temperatures, as both andalusite and cyanite when heated to 1400° C. pass over to sillimanite on cooling.

In rock sections andalusite appears in almost square or in elongated outlines. Relief is marked, and the pleochroism shows only in the colored varieties. Inclusions are symmetrically arranged. Interference colors are yellows of the first order.

Andalusite is the result of metamorphism and is developed in some gneisses and schists, where it is associated with sillimanite, cyanite, iolite, garnets, corundum, and tourmalines. Specimens with typical inclusions are found at Lancaster, Massachusetts, and Rochester, New Hampshire. It is a common mineral at numerous points in New England.

The name andalusite is derived from the noted locality of Andalusia, in Spain.

Andalusite in weathering is decomposed by percolating waters containing alkalis, forming micas and kaolinite.

SILLIMANITE

Sillimanite. — $\text{Al}(\text{AlO})\text{SiO}_4$; $\text{AlO}_3 = 63$; $\text{SiO}_2 = 37$; Orthorhombic; $\bar{a} : \bar{b} : \bar{c} = .970 : 1 : ?$ $110_A \bar{1}\bar{1}0 = 88^\circ 15'$; $230_A \bar{2}30 = 69^\circ$; Common forms, **a** (110), **b** (010), **m** (110), **h** (230); Cleavage, **b** perfect; Brittle; Fracture, uneven; $\cdot\text{H.} = 6-7$; $\text{G.} = 3.23-3.24$; Color, shades of gray, brown, and green; Streak, white; Luster, vitreous; Transparent to opaque; $\alpha = 1.660$; $\beta = 1.661$; $\gamma = 1.681$; $\gamma - \alpha = .020$; Axial plane = 010; $\text{Bx}_a = \bar{c}$; Optically (+); $2V = 31^\circ 19'$.

B.B. — Like andalusite.

General description. — Crystals are slender, elongated, parallel to the vertical axis; from this habit the mineral is sometimes known as fibrolite. Terminations have never been observed. Also in compactly massed fibers arranged parallel or radiating. In sections sillimanite may be distinguished from andalusite by the fibrous structure, by the higher double refraction yielding interference colors of the second order, and by the optical character being positive.

In occurrence and decomposition by weathering, it resembles andalusite.

CYANITE

Cyanite. — Disthene, $\text{Al}(\text{AlO})\text{SiO}_4$; $\text{Al}_2\text{O}_3 = 63$, $\text{SiO}_2 = 37$; Triclinic; Type, Centro-symmetric; $\bar{a} : \bar{b} : \bar{c} = 0.8994 : 1 : .7089$; $\alpha = 90^\circ 5'$; $\beta = 101^\circ 2'$; $\gamma = 105^\circ 44'$; $100_A 010 = 73^\circ 56'$; $100_A 001 = 78^\circ 30'$; $010_A 001 = 86^\circ 45'$; $100_A 110 = 34^\circ 17'$; Common forms, **a** (100), **b** (010), **c** (001), **m** (110); Twinning plane, 100; Cleavage, **a** perfect, **b** less so and parting parallel to **c**; Brittle; Fracture, fibrous; $\text{H.} = 5-7.25$; $\text{G.} = 3.56-3.67$; Color, blue, white, reddish, and green; Luster, vitreous; Transparent to translucent; $\alpha = 1.717$; $\beta = 1.722$; $\gamma = 1.729$; $\gamma - \alpha = .012$; Optically (-); Bx_a nearly normal to 100; $2V = 82^\circ$.

B.B. — Like andalusite.

General description. — Crystals are long, bladelike in habit, combinations of the two pinacoids **a** and **b**, with the unit prism;

the *a* pinacoid is often striated longitudinally. Terminations are very rare. The two pinacoidal cleavages are at an angle of 106° with a cross parting parallel to the base. The hardness is remarkable for its variation with the direction; when tested parallel to



FIG. 492. — Cyanite, Pizzo Eorno, St. Gothard, Switzerland.

the length of the crystal, on *a*, the hardness is nearly 7, but when tested at right angles to this direction on the same face its hardness is only 4.

Cyanite is a mineral produced by metamorphic agents and is never found as a pyrogenetic mineral in igneous rocks, but is associated with staurolite and garnets in crystalline schists.

Typical specimens are found at Litchfield and Newton, Connecticut; in Yancey County, North Carolina. The rare white and yellow variety rhaetizite is found in the Zillerthal and Pfitschthal Tyrol. Most beautiful specimens occur at Pizzo Forno, St. Gothard, Switzerland, in a paragonite schist, associated with staurolite, with which it is often in parallel position.

In its alterations cyanite is like sillimanite and andalusite.

When the constituent oxides in the required proportion are fused, sillimanite is formed; just what are the conditions required to produce the two less stable forms, cyanite and andalusite, is not as yet exactly known.

BASIC ORTHOSILICATES

DATOLITE

Datolite. — A borosilicate of calcium, $\text{Ca}(\text{BOH})\text{SiO}_4$; $\text{CaO} = 35.0$, $\text{B}_2\text{O}_3 = 21.8$, $\text{SiO}_2 = 37.6$, $\text{H}_2\text{O} = 5.6$; Monoclinic; Type, Digonal Equatorial; $\mathbf{a} : \mathbf{b} : \mathbf{c} = .6344 : 1 : 1.2657$; $\beta = 89^\circ 51' = 100^\wedge 001$; $100^\wedge 110 = 32^\circ 24'$; $001^\wedge 101 = 63^\circ 16'$; $001^\wedge 011 = 51^\circ 41'$; Common forms, \mathbf{c} (001), \mathbf{a} (100), \mathbf{m} (101), \mathbf{m}_x (011), \mathbf{n} (111), \mathbf{b} (010), \mathbf{g} (012), \mathbf{x} (102), other forms also numerous; Cleavage, none; Brittle; Fracture, uneven; H. = 5–5.5; G. = 2.9–3; Color, white, pale green, or yellow; Streak, white; Luster, vitreous; Transparent to translucent; $\alpha = 1.624$; $\beta = 1.652$; $\gamma = 1.669$; $\gamma - \alpha = .045$; Optically (-); Axial plane = 010; $\mathbf{Bx}_\wedge \mathbf{c} = 1^\circ - 4^\circ$ in the acute angle β .

B.B. — Fuses easily with intumescence, and in the forceps alone yields a green flame (boron). Gelatinizes with HCl. In the closed tube yields water.

General description. — Crystals are short, prismatic, or equidimensional combinations of \mathbf{a} , \mathbf{m} , \mathbf{c} , \mathbf{n} , \mathbf{x} , \mathbf{m}_x , and \mathbf{m} , all of which are very bright, with a high luster, except \mathbf{x} , which is dull. A massive form, very much like porcelain on fracture surfaces, occurs in the Lake Superior copper regions.

Datolite is a secondary mineral deposited from solutions in the cavities, cracks, and veins, especially of basalts and gabbros, where it is associated with calcite, zeolites, prehnite, and quartz. It is a common mineral in the quarries opened in the traps of the New England and Middle states. Fine specimens have been obtained at Bergen Hill and Patterson, New Jersey; at Westfield, Massachusetts, and at New Haven, Connecticut.

EPIDOTE GROUP

The epidote group is made up of basic orthosilicates of the general formula $\text{R}''_2\text{R}'''_2(\text{AlOH})(\text{SiO}_4)_3$, in which R'' is Ca, Mn, or Fe, and R''' is Al, Fe, Ce, or Mn. Some epidotes are orthorhombic, but

with the increase of iron and manganese in the formula they become monoclinic.

ZOISITE

Zoisite. — A basic orthosilicate of calcium and aluminium; $\text{Ca}_2\text{Al}_2(\text{AlOH})(\text{SiO})_3$; $\text{CaO} = 24.6$, $\text{Al}_2\text{O}_3 = 33.7$, $\text{SiO}_2 = 39.7$, $\text{H}_2\text{O} = 2.0$; Orthorhombic; Type, Didigonal Equatorial; $\bar{a} : \bar{b} : \bar{c} = .6196 : 1 : .3429$; $100_\wedge 110 = 31^\circ 47'$; $001_\wedge 101 = 28^\circ 58'$; $001_\wedge 011 = 18^\circ 56'$; Common forms, $a(100)$, $b(010)$, $m(110)$, $o(111)$, $d(101)$, $f(011)$, $r(120)$; Cleavage, b perfect; Brittle; Fracture, uneven; $H. = 6-6.5$; $G. = 3.25-3.37$; Color, gray, white, or pale shades of green, pink, red, or yellow; Streak, white; Luster, vitreous to pearly; $\alpha = 1.696$; $\beta = 1.696$; $\gamma = 1.702$; $\gamma - \alpha = .006$; Optically (+); Axial plane = 010 at times 001; $Bx_\wedge = \bar{a}$; $2V = 0-60^\circ$.

B.B. — Fuses with intumescence at three to a white blebby slag, gelatinizes after fusion. After strong ignition in the closed tube yields water.

General description. — Crystals are prismatic in habit, elongated parallel to the vertical axis, while epidote is elongated parallel to the orthoaxis; in the comparison of these two minerals the \bar{c} axis of zoisite is equivalent to the \bar{b} axis of epidote. Deep striations on the prism zone parallel to the vertical axis are characteristic. The crystals are rarely terminated, occurring in parallel or divergent groups; also massive.

Thulite is a pink variety from Norway, and Traversella, in Piedmont; the pink color is due to manganese.

Zoisite contains but little iron and is essentially an aluminium epidote. Clinozoisite is a light-colored variety of epidote with small amounts of iron; the characteristic pistachio-green color of epidote deepens with the increase of iron in the molecule.

In rock sections zoisite appears in elongated crystals or granular; colorless, or pale; with the cleavage cracks parallel to the macropinacoid distinctly developed. Relief is high, but the interference color is a low first order gray. Extinction parallel. The plane of the optic axis is usually parallel to the base, but at times may be parallel to the macropinacoid. Optically (+).

Zoisite is associated with the crystalline schists; rarely is it found in granites or igneous rocks. As a secondary mineral it is

derived from the alteration of the plagioclases. Saussurite is a mixture of plagioclase and zoisite in various proportions.

It occurs in various localities in Massachusetts, Connecticut, and North Carolina; at Ducktown, Tennessee; and in the Coast Range, California. The synthesis of zoisite is uncertain, as the products of various fusions have contained no water.

EPIDOTE

Epidote. — A basic orthosilicate of calcium aluminium and iron, $\text{Ca}_2(\text{AlFe})_2(\text{AlOH})(\text{SiO}_4)_3$; $\text{CaO} = 23.73$, $\text{Al}_2\text{O}_3 = 25.95$, $\text{Fe}_2\text{O}_3 = 10.18$ (when $\text{Fe} : \text{Al} :: 4 : 1$), $\text{SiO}_2 = 35.20$, $\text{H}_2\text{O} = 1.91$; Monoclinic; Type, Digonal Equatorial; $\mathbf{a} : \mathbf{b} : \mathbf{c} = 1.5787 : 1 : 1.8036$; $\beta = 64^\circ 37' = 100_\wedge 001$; $100_\wedge \bar{1}\bar{1}0 = 55^\circ$; $001_\wedge 101 = 34^\circ 43'$; $001_\wedge 011 = 58^\circ 28'$; Common forms, c (001), a (100), m (110), e (101), r ($\bar{1}01$), o (011), d (111); Twinning plane, 100 contact twins, also 001, but rare; Cleavage, basal perfect and a imperfect; Brittle; Fracture, uneven; $H. = 6-7$; $G. = 3.25-3.5$; Color, shades of green, also yellow, red, or gray; Streak, white; Luster, vitreous; Transparent to opaque; $\alpha = 1.724$; $\beta = 1.729$; $\gamma = 1.734$; $\gamma - \alpha = .010$; Optically (—); Axial plane = 010; $Bx_\alpha \wedge c$ $2^\circ-3^\circ$ in the acute angle β ; $2V = 73^\circ-88^\circ$.

B.B. — Fuses at three with intumescence to a black blebby glass, which when powdered is generally magnetic and gelatinizes with HCl. After strong ignition in the closed tube yields water.

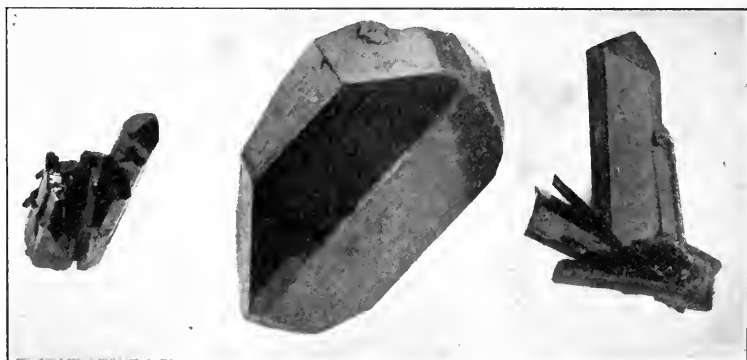

FIG. 493. — Epidote, Sulzbachthal, Tyrol. The Central Figure is from Prince-of-Wales Island, Alaska.

General description. — Crystals are elongated parallel to the orthoaxis, with terminations generally rich in faces; often twinned

as is indicated by the reëntrant angle. Particularly fine specimens of this habit occur in a chloritic schist, associated with adularia, apatite, titanite, and calcite, in the Sulzbachthal, Tyrol. A tabular habit, though not as common as the elongated habit, also occurs, good specimens of which are obtained on the Prince of Wales Island, Alaska; these are also twinned, the twinning being revealed by the striations on the clinopinacoidal face. Massive

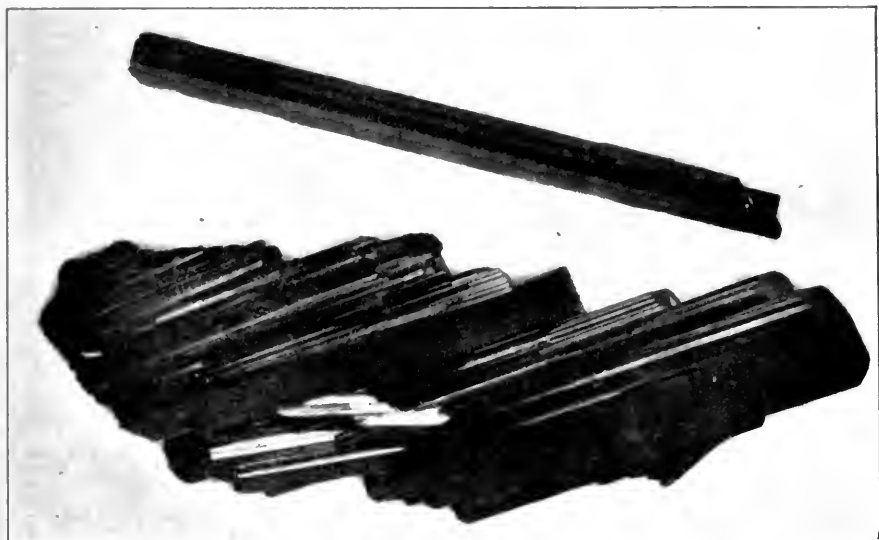

FIG. 494. — Epidote. Sulzbachthal, Tyrol.

and granular epidote mixed with quartz occurs as the rock epidosite; it is derived from the alteration of plagioclase feldspars together with some ferromagnesian mineral, as pyroxene or amphibole.

Piedmontite is a brown or red epidote in which the iron is replaced by manganese; it occurs in Piedmont, Italy, and also in a rhyolite at South Mountain, Pennsylvania.

In rock sections epidote appears colorless, pale yellow, or brown, depending upon the percentage of iron; in tabular or elongated crystals, at times intergrown with zoisite. The relief is high, and the basal cleavage cracks are distinct. Pleochroism is strong in the colored varieties, and much less in the colorless, or those poor in iron. Interference colors are high, as the double refraction may vary from .03 to .06. The extinction is inclined and varies from 2

to 3° with the imperfect orthopinacoidal cleavage cracks. Basal cleavage fragments show one optic axis, while the acute bisectrix is nearly perpendicular to 100. Optically (-).

Epidote appears as a secondary mineral in igneous rocks and in schists, where it is derived from the alteration of feldspars and pyroxene or amphibole, usually associated with chlorite. It is also the product of metamorphism, and is found in contact zones, as well as in granular limestones where it is associated with vesuvianite, garnets, hematite, and pyroxenes. It rarely occurs as a primary mineral of igneous rocks. In the United States epidote is a common mineral at various localities along the Atlantic slope in the New England, Middle, and Southern states. Its synthesis, like zoisite, is uncertain.

ALLANITE

Allanite. — $\text{Ca}_2(\text{Al} \cdot \text{Ce} \cdot \text{Fe})_2(\text{AlOH})(\text{SiO}_4)_3$; Composition variable; Monoclinic; Type, Digonal Equatorial; $\mathbf{a} : \mathbf{b} : \mathbf{c} = 1.5509 : 1 : 1.7691$; $\beta = 64^\circ 39' = 100^\wedge 001$; $100^\wedge 110 = 54^\circ 34'$; $001^\wedge 101 = 63^\circ 24'$; $001^\wedge 001 = 58^\circ 3'$; Common forms, \mathbf{c} (001), \mathbf{a} (100), \mathbf{m} (110), \mathbf{d} (111), \mathbf{n} ($\bar{1}11$); Twinning plane, 100; Cleavage, 100 and 001 in traces; Brittle; Fracture, uneven; $\mathbf{H.} = 5.5\text{--}6$; $\mathbf{G.} = 3.5\text{--}4.2$; Color, pitch brown to black or yellowish; Streak, pale gray or greenish; Luster, pitchy to dull; Opaque to subtranslucent.

B.B. — Fuses easily with intumescence. Becomes magnetic in R. F. After strong ignition in the closed tube yields water. Gelatinizes with HCl; the solution freed of silica yields reactions for cerium, page 571.

General description. — Either tabular in habit parallel to 100, or acicular parallel to the orthoaxis; also granular or massive.

The elongated variety has been described under the name of orthite; it contains much water, even as high as 17 per cent., while the true allanite contains only one or two per cent.

Allanite is an epidote in which some of the iron is replaced by the rare elements, cerium, lanthanum, didymium, yttrium, or erbium; the amount of each varies with the locality; the total of them all is about 20 per cent.

Allanite occurs as an accessory mineral in igneous rocks, more often in those rich in silica, as granites and pegmatites; also in schists and crystalline limestones.

It is found at many localities along the Atlantic slope, as South Mountain, Pennsylvania; Edenville, New York; Haddam, Connecticut; Franklin, New Jersey; Amelia Court House, Virginia; Bethany Church, Iredell County, North Carolina.

AXINITE

Axinite. — A borosilicate of calcium and aluminium, $\text{HCa}_3\text{-Al}_2\text{B}(\text{SiO}_4)_4$; Composition variable; Triclinic; Type, Centrosymmetric; $\tilde{a} : \tilde{b} : \tilde{c} = .4921 : 1 : .4797$; $\alpha = 82^\circ 54'$; $\beta = 91^\circ 52'$; $\gamma = 131^\circ 32'$; $010_{\wedge}100 = 48^\circ 21'$; $100_{\wedge}001 = 93^\circ 49'$; $010_{\wedge}001 = 97^\circ 50'$; $110_{\wedge}100 = 15^\circ 34'$; $\bar{1}10_{\wedge}100 = 28^\circ 53'$; Common form, **a** (100), **b** (010), **c** (001), **m** (110), **M** ($\bar{1}10$), **r** ($1\bar{1}1$), **x** (111), **e** ($\bar{1}\bar{1}1$); Cleavage 010 distinct, Brittle; Fracture, conchoidal; H. = 6.5–7; G. = 3.27 – 3.29; Color, brown, blue, gray, or yellow; Streak, white or pale; Transparent to translucent; $\alpha = 1.685$; $\beta = 1.692$; $\gamma = 1.695$; $\gamma - \alpha = .010$; Optically (–); Bx_a nearly perpendicular to 111; $2V = 71^\circ 38'$.

B.B. — Fuses easily with intumescence, yielding a green flame (boron). Gelatinizes with HCl after fusion, but insoluble before. May yield an iron or manganese reaction with the fluxes.



FIG. 495. — Axinite from Dauphine, France.

General description. — Crystals flattened, with the forms **r**, **M**, and **m** prominent, with edges sharp like an axe, hence the name

axinite. Striations on the prism zone parallel to the vertical axis are characteristic. The color is usually clove-brown, but varies with the replacement of calcium with iron or manganese.

Like most other borates, axinite is formed by pneumatolytic action, and therefore usually appears in the cracks and veins of granites and diabases, or in metamorphic contact zones.

Fine crystals implanted on the walls of veins in diabase occur at Bourg d'Oisans, Dauphine', France; at St. Gothard, Switzerland. In the United States it occurs at Franklin, New Jersey, in yellow crystals associated with garnets and rhodonite; at Bethlehem, Pennsylvania, and at Phippsburg, Maine.

PREHNITE

Prehnite. — An orthosilicate of calcium and aluminium; $H_2Ca_2Al_2(SiO_4)_3$; $CaO = 27.1$, $Al_2O_3 = 24.8$, $SiO_2 = 43.7$, $H_2O = 4.4$; Orthorhombic; Type, Didigonal Equatorial; $a : b : c = .8401 : 1 : .5549$; $100_A 110 = 40^\circ 2'$; $001_A 101 = 33^\circ 27'$; $001_A 011 = 29^\circ 2'$; Common forms, c (001), a (100), b (010), m (110), o (061); Cleavage, basal distinct; Brittle; Fracture, uneven; $H. = 6-6.5$; $G. = 2.8-2.95$; Color, light green, oil-green, yellow, white; Streak, white; Luster, vitreous; Nearly transparent to translucent; $\alpha = 1.616$; $\beta = 1.626$; $\gamma = 1.649$; $\gamma - \alpha = .033$; Optically (+); Axial plane = 010; $Bx_a = c$; $2V = 69^\circ 22'$.

B.B. — Fuses easily with intumescence to a blebby glass and gelatinizes after fusion with HCl. After the separation of silica and aluminium with ammonia, yields a heavy white precipitate with ammonium carbonate (calcium). Yields water in the closed tube.



FIG. 496. — Prehnite. Bergen Hill, New Jersey.

General description. — Crystals are small and rarely simple, but in parallel position or joined in ridged groups with a rough surface on which the individual crystals may be seen to be joined by the base, with the

prism angle free on the surface. Often globular or botryoidal with very small crystal faces. The nodules when broken show a radiated structure. The color is nearly always light green or yellowish, the color fading on exposure.

Prehnite is a secondary mineral formed from solution in the cavities and veins of the basic igneous rocks, where it is associated with the zeolites, datolite, calcite, and quartz. It is a common mineral in the cracks of the traps of Massachusetts, Connecticut, and New Jersey; also in the Lake Superior copper regions.

It forms pseudomorphs after analcite, natrolite, and the plagioclases, and decomposes, forming chlorite.

When fused it breaks down and on cooling yields wollastonite.

CHONDRODITE

Chondrodite. — $[\text{Mg}(\text{F} \cdot \text{OH})]_2\text{Mg}_3(\text{SiO}_4)_2$; Monoclinic; Type, Digonal Equatorial; $\mathbf{a} : \mathbf{b} : \mathbf{c} = 1.0863 : 1 : 3.1447$; $\beta = 90^\circ = 100_A$ 001; $100_A 110 = 47^\circ 22'$; $001_A 101 = 70^\circ 57'$; $001_A 011 = 72^\circ 22'$; Common forms, \mathbf{c} (001), \mathbf{b} (010), \mathbf{r}_2 (125), \mathbf{r}_3 ($\bar{1}23$); Twinning plane, 105; Cleavage, basal; Brittle; Fracture, conchoidal; $H. = 6-6.5$; $G. = 3.1-3.2$; Color, shades of yellow, brown, and red; Streak, white or pale yellow; Luster, vitreous; Transparent to translucent; $\alpha = 1.607$; $\beta = 1.619$; $\gamma = 1.639$; $\gamma - \alpha = .032$; Optically (+) axial plane perpendicular to 010; $\mathbf{Bx}_o \wedge \mathbf{c} = 25^\circ 30'$; $2\mathbf{V} = 79^\circ 40'$.

B.B. — Infusible, but whitens. Gelatinizes with HCl. Yields a fluorine reaction in the closed tube. Often reacts for iron with the fluxes.

General description. — Crystals are equidimensional; at times flattened parallel to 010, with striations on the orthodome parallel to the orthoaxis; crystals are complicated and very rich in forms; also granular and massive.

Chondrodite is a member of the humite group; the other members are humite, $[\text{Mg}(\text{F} \cdot \text{OH})]_2\text{Mg}_5(\text{SiO}_4)_2$; clinohumite $[\text{Mg}(\text{F} \cdot \text{OH})]_2 \text{Mg}_7(\text{SiO}_4)_4$.

In composition they differ from each other by MgSiO_4 . Humite is orthorhombic, while the others are monoclinic. They agree very closely in their occurrences, associations, and physical properties. They occur in metamorphic limestones containing considerable magnesia. All three are found in the ejected blocks of limestone on Monte Somma, Vesuvius, and at the Tilly Foster mine, Brew-

ster, New York, associated with serpentine. Chondrodite occurs at Sparta, New Jersey, and at Amity and Warwick, New York, in a limestone associated with spinel.

By hydration they alter to serpentine and sometimes to brucite.

ILVAITE

Ilvaite. — $\text{CaFe}_2(\text{FeOH})(\text{SiO}_4)_2$; $\text{CaO} = 13.7$; $\text{FeO} = 35.2$; $\text{Fe}_2\text{O}_3 = 19.6$; $\text{SiO}_2 = 29.3$; $\text{H}_2\text{O} = 2.2$; Orthorhombic; Type, Didigonal Equatorial; $\tilde{a} : \tilde{b} : \tilde{c} = .6665 : 1 : .4427$; $100_{\wedge} 110 = 33^\circ 41'$; $001_{\wedge} 101 = 33^\circ 35'$; $001_{\wedge} 011 = 23^\circ 53'$; Common forms, **b** (010), **m** (110), **s** (120), **o** (111); Cleavage, **b** and **c** distance **a** and **m** less so; Brittle; Fracture, uneven; $H. = 5.5-6$; $G. = 3.99-4.05$; Color, iron-black; Streak, black to brownish; Luster, sub-metallic; Opaque.

B.B. — Fuses easily with some intumescence to a slag which is magnetic; gelatinizes with HCl. Manganese may replace some of the iron, when it will yield reactions for that metal.

General description. — Crystals are prismatic in habit, with striations on the prism zone parallel to the vertical axis. It is not a common mineral; it occurs on the isle of Elba in a dolomite, and takes its name from the Latin term for the island. It has also been reported as from Somerville, Massachusetts, and Cumberland, Rhode Island.

The crystals are not unusually coated with a yellow or brown oxide of iron, which is the result of oxidation.

CALAMINE

Calamine. — Hemimorphite; Hydrous orthosilicate of zinc; $\text{Zn}_2\text{SiO}_4 \cdot \text{H}_2\text{O}$; $\text{ZnO} = 67.5$; $\text{SiO}_2 = 25.0$; $\text{H}_2\text{O} = 7.5$; Orthorhombic; Type, Didigonal Polar; $\tilde{a} : \tilde{b} : \tilde{c} = .7834 : 1 : .4778$; $100_{\wedge} 110 = 38^\circ 4'$; $001_{\wedge} 101 = 31^\circ 23'$; $001_{\wedge} 011 = 25^\circ 32'$; Common forms, **b** (010), **c** (001), **m** (110), **i** (031), **v** (121), **t** (301); Twinning plane 001, supplementary twins; Cleavage, prismatic perfect; Brittle; Fracture, uneven; $H. = 4.5-5$; $G. = 3.40-3.50$; Color, white, brown, or yellow; Streak, white; Luster, vitreous to adamantine; Transparent to translucent; Pyroelectric; $\alpha = 1.613$; $\beta = 1.617$; $\gamma = 1.636$; $\gamma - \alpha = .023$; Optically. (+); Axial plane 100; $\text{Bx}_a = \tilde{c}$; $2\text{E} = 78^\circ 39'$; $2\text{V} = 46^\circ 9'$.

B.B. — Fuses with difficulty. With soda and borax in R. F. on coal yields a zinc oxide coat. Gelatinizes with HCl. In the closed tube yields water.

General description. — Crystals are tabular in habit or prismatic, flattened parallel to 010, with striations lengthwise. Polar in development, with one end terminated by the brachydome zone, while the other is terminated by pyramids. They are almost always implanted on the pyramid termination, with the domes free, and joined by the large face 010 in parallel positions, forming ridges and crystalline crusts, with a drusy surface; or in nodules which show a radiated structure when broken. Simple, free crystals are rare; they occur at Altenberg, in Saxony.

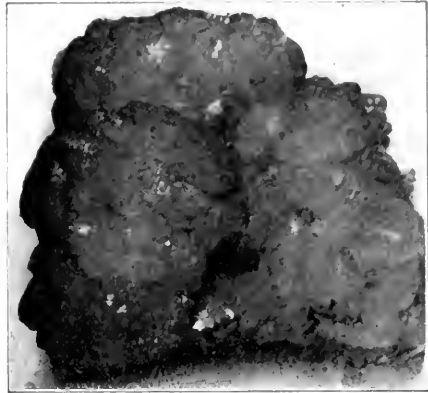

FIG. 497. — Calamine from Stirling Hill, New Jersey.

It also occurs as crusts, stalactitic, mamillary, granular, or earthy and amorphous; the amorphous variety is softer than the crystalline. Calamine is a secondary mineral deposited from solution at low temperatures. The percolating ground waters carry zinc silicate, the zinc being derived from the oxidation of sphalerite which unites with the silica in solution, forming calamine.

Calamine is characteristic of the zone of oxidation and is associated with the superficial area of most zinc deposits. Beautiful specimens were formerly obtained at Stirling Hill and Franklin, New Jersey. It also occurs at Friedensville, Pennsylvania; Granby, Missouri; Virginia; Colorado; and Utah.

TOURMALINE

Tourmaline. — A borosilicate of aluminium, the alkalis and alkali earth metals, of the general formula $R_9Al_3(B.OH)_2Si_4O_{19}$, in which R may be Li, K, Na, H, Ca, Fe, or Mg and Al may be replaced by Fe or Cr, and OH by fluorine. The composition is therefore variable, but always contains B_2O_3 about 10 per cent.,

Al_2O_3 from 25 to 40, and SiO_2 , 35 to 40 per cent.; Hexagonal; Type, Ditrigonal Polar; $\hat{c} = .4477$; $0001 \wedge \bar{1}011 = 27^\circ 20'$; $\bar{1}011 \wedge 10\bar{1}1 = 46^\circ 52'$; $01\bar{1}2 \wedge 0\bar{1}12 = 25^\circ 2'$; $02\bar{2}1 \wedge 0\bar{2}21 = 77^\circ$; Common forms, *c* (0001), *m* ($10\bar{1}0$), *a* ($11\bar{2}0$), *r* ($10\bar{1}1$), *o* ($02\bar{2}1$), *e* ($01\bar{1}2$); Other forms numerous; Twinning plane 0001, supplementary twins, other twins rare; Cleavage, *a* and *r* difficult; Brittle; Fracture, uneven; H. = 7–7.6; G. = 2.98–3.20; Color, commonly dark brown to black, but all shades of green, blue, red, to white; Streak, white or gray; Transparent to opaque; $\omega = 1.640$; $\epsilon = 1.622$; $\omega - \epsilon = .018$; Optically (–).

B.B. — Generally fuses to a slag or glass, with a change in color; but some varieties fuse with difficulty, or are infusible. With Turner's flux yields a boric acid flame (green). Not attacked by acids.

General description. — Crystals are either long and slender, parallel to the vertical axis, or short and stout, with striations on the prism zone lengthwise; combinations of the hexagonal prism of the second order and the trigonal prism of the first order. Oscilla-

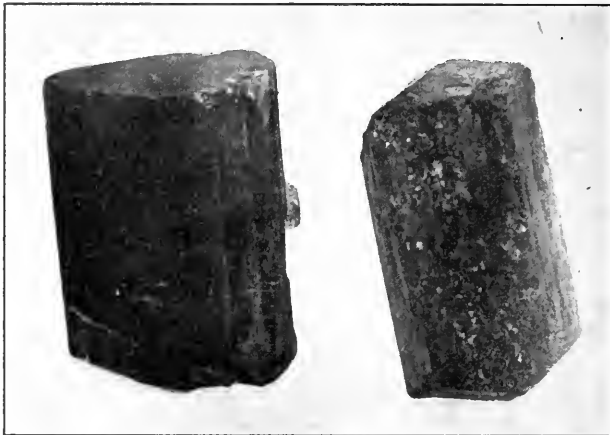

FIG. 498. — Tourmaline from Mesa Grande, California. The Smaller Specimen is from Acworth, New Hampshire.

tions in growth between these two forms produce the striations so characteristic. They may be deep furrows or ridged, in which the cross section becomes only approximately trigonal; such crystals are well represented by those from Mesa Grande, California.

In the black variety, schorl, the polar character of the mineral is

well illustrated by the double terminated crystals from Pierrepont, New York, where they occur in a limestone. They are short, stout prisms, combinations of *a* and *m*, and less commonly the ditrigonal prism *h* (41 $\bar{5}$ 0) in the prism zone, terminated at one end by the pyramids *r* and *e*, which are flat. At the other end they are terminated by the much steeper pyramid *o* and a small basal plane; the two ends are quite different in appearance.

Owing to the great variation in composition possible, tourmaline differs widely in color. The transparent pale pink, blue, green, and colorless specimens are rich in alkalis. Their color is often unevenly distributed, as different parts of the same specimen will differ in color; this distribution of color may be from end to end, one end being colorless, green, or pink, while the other may be blue; or the distribution may be concentric around the vertical axis, as in the Brazilian specimens, in many of which the central axis is pink, then a colorless area, while the outside is green. Beautifully colored and transparent tourmalines are obtained at Haddam, Connecticut; Paris, Maine; Mesa Grande, California; Madagascar; and Brazil. When transparent and flawless, they are cut and polished as gems. The pink varieties are known as rubellite, the green as Brazilian emeralds, the yellow as Ceylon peridot, the blue as indicolite, and the white as achroite.

The black varieties are rich in iron; that from Pierrepont contains 9.08 per cent. of FeO. The brown varieties are high in magnesium; that of Gouverneur, New York, contains 14.9 per cent. of MgO.

Tourmaline is very strongly pleochroic; even the gems cut from the transparent specimens are often of different color, according to the direction in which the light passes through the crystal. This absorption is more strongly marked in the darker varieties and is developed to such an extent in the dark brown specimens that in a section parallel to the vertical axis the ordinary ray is entirely absorbed. Such sections are used, as in the tourmaline tongs, to replace the nicols in viewing interference figures of mineral sections placed between them.

Tourmaline is also the best example of the pyroelectric property in minerals. When a crystal of tourmaline is cooling after being heated, one end, the analogous end (the sharp end), is usually negatively charged, while the antilogous end (the blunt end) is positively charged. The reverse of this is true when the temperature is rising. If a crystal of tourmaline after being heated is dusted

with a mixture of flowers of sulphur and powdered red lead, the positively charged end of the crystal becomes yellow as it attracts the sulphur, and the negatively charged end becomes red as it attracts the red lead.

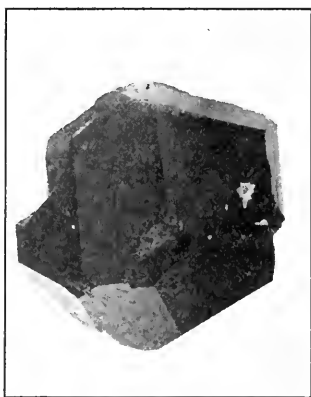

FIG. 499.—Tourmaline. Jefferson County, New York.

In rock sections it appears elongated, branched, and needle-like; when cut perpendicular to the vertical axis, roughly triangular. In color, white and pale shades, to brown and green, especially in rock-forming tourmalines. Relief is well marked and absorption very strong, particularly in the dark varieties. Interference colors, low second order; the basal section shows a dark cross only, in thin sections. Optically (-).

The black tourmaline occurs as a primary component in some granites; other tourmalines are mostly formed by fumarole action, caused by the contact of igneous intrusions with limestones or sedimentary rocks. Boron is the commonest of the pneumatolytic agents. Tourmaline is therefore a common mineral in pegmatites, crystalline schists, and granular limestones, and is usually associated with cassiterite, topaz, fluorite, beryl, lepidolite, the various micas, and quartz.

In the United States the noted localities for varicolored specimens are Haddam, Connecticut; Paris, Maine; Mesa Grande, California, where it is found in pegmatites associated with lepidolite, spodumene, and beryl.

The brown variety occurs at Gouverneur, New York; Franklin, New Jersey; Unionville, Pennsylvania, in limestones associated with scapolite, spinels, or tremolite. Also in many of the Maine pegmatites; near San Diego, California, in large black crystals six inches across, in a feldspar.

Tourmaline alters to chlorite, muscovite, or biotite, with which minerals it is generally associated.

Synthetically tourmaline has never been produced in the laboratory. In nature it must be formed at rather a low temperature, or under pressure, as upon fusion it breaks down, forming minerals with less complex molecules, as olivine and spinel.

STAUROLITE

Staurolite. — $\text{HFeAl}_5\text{Si}_2\text{O}_{13}$; Composition variable; Orthorhombic; Type, Didigonal Equatorial; $\bar{a} : \bar{b} : \bar{c} = .4734 : 1 : .6828$; $100 \wedge 110 = 25^\circ 20'$; $001 \wedge 101 = 55^\circ 16'$; $001 \wedge 011 = 34^\circ 19'$; Common forms, c (001), b (010), m (110), r (011); Twinning plane, x (032), also z (232), both common; y (130); rare; Cleavage, b distinct, m in traces; Brittle; Fracture, uneven; $H. = 7-7.5$; $G. = 3.65-3.75$; Color, shades of dark brown to nearly black; Streak, white to yellowish; Luster, vitreous to resinous; Translucent to opaque; $\alpha = 1.736$; $\beta = 1.741$; $\gamma = 1.746$; Optically (+); $\gamma - \alpha = .010$; Axial plane = 100; $Bx_a = \bar{c}$; $2V = 88^\circ 46'$.

B.B. — Infusible; when containing much manganese fuses at 4. With borax and S. Ph. yields an iron reaction. Insoluble in acids.

General description. — In crystalline habit, short prismatic, combinations of the unit prism, macrodome, and the basal and brachypinacoids. The surface is often dull from alterations.

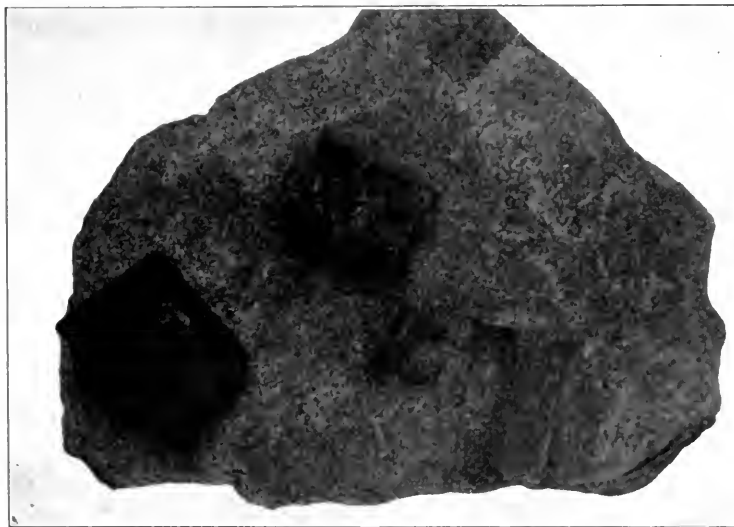

FIG. 500. — Staurolite. Windham, Maine.

Interpenetrating twins in which the composition face is 032, and the vertical axes of the two individuals are at right angles, are characteristic, and it is from this twinning that the name staurolite, "cross-shaped," is derived, Fig. 297. Twins in which the vertical

axes are at 60° , with 232 as the composition face, are also common.

In rock sections staurolite is pale yellow to reddish brown, usually in crystalline outline, containing numerous inclusions, often of carbonaceous matter, at times symmetrically arranged. Relief is high, interference colors gray to yellow of the first order. The interference figure is in the basal section. The optic axes lie without the field of view.

It is a product of contact metamorphism, occurring in argillaceous shales and schists, associated with cyanite, sillimanite, and garnets.

Beautiful specimens occur at Pizzo Formo, near St. Gothard, Switzerland, where it is found in a paragonite schist associated with cyanite, often in parallel growths.

At Windham, Maine, crystals nearly two inches in length are embedded in a mica slate associated with cyanite and small garnets. It occurs also at Franconia, New Hampshire; at Sheffield, Massachusetts, at many points in Connecticut, Virginia, North Carolina, and Georgia. In Lincoln and Fannin counties, Georgia, many simple and twinned crystals lie loose in the soil or in the decomposed schist. It is not easily altered by weathering, but at times forms muscovite, or a steatite-like substance mixed with quartz.

The synthesis of staurolite, like many other contact and pneumatolytic minerals, has not as yet been accomplished with certainty.

ZEOLITES

The zeolites are a group of hydrated silicates of aluminium with either calcium and the alkalis, or both. Calcium may be replaced by barium or strontium, but there is little or no magnesium. In their occurrence, they are not found as primary minerals, but they are all secondary products derived by the hydration of such primary minerals as the feldspars, nepheline, or leucite. They may be found in the mass of the rock containing the minerals of which they are hydration products, or they may be found filling the pores, cracks, and other cavities in which they have been precipitated or crystallized from solution.

They are common minerals associated with such rocks as diabase, diorite, syenites, and those containing leucite, nepheline, or sodalite. They are also less commonly found connected with the metamorphosed, or even the semimetamorphosed, sedimentary

ZEOLITES

NAME	COMPOSITION	SYSTEM	SiO ₂	Al ₂ O ₃	CaO	K ₂ O	Na ₂ O	H ₂ O
Apophyllite	H ₁₁ K ₂ Ca ₈ (SiO ₂) ₁₆ · 9 H ₂ O	II	53.7		25.0	5.2		16.1
Pitohite	(Ca · K ₂ · Na ₂)Al ₂ Si ₁₀ O ₂₁ · 5 H ₂ O	V	70.35	11.90	3.87	2.83	0.77	10.18
Mordenite	(Ca ₂ · Na ₂ · K ₂)Al ₂ Si ₁₀ O ₂₁ · 6½ H ₂ O	V	66.40	11.17	1.94	3.58	2.27	13.31
Heulandite	H ₄ CaAl ₂ (SiO ₃) ₆ · 3 H ₂ O	V	59.2	16.8	9.2			14.8
Brewsterite	H ₄ (Sr · Ba · Ca)Al ₂ (SiO ₃) ₆ · 3 H ₂ O	V	54.42	15.25	1.19	6.89 BaO	8.99 SrO	13.22
Epistilbite	H ₄ CaAl ₂ (SiO ₃) ₆ · 3 H ₂ O	V	59.2	16.8	9.2			14.8
Wellsite	(Ba · Ca · K ₂)Al ₂ Si ₃ O ₁₀ · 3 H ₂ O	V	43.86	24.96	5.80	3.40	3.80	13.35
								5.07 BaO
								3.15 SrO
								.62 MgO
								16.5
Phillipsite	(K ₂ · Ca)Al ₂ (SiO ₃) ₄ · 4½ H ₂ O	V	48.8	20.7	7.6	6.4		
Harmotome	H ₂ (K ₂ · Ba)Al ₂ (SiO ₃) ₅ · 5 H ₂ O	V	47.1	16.0	20.6 BaO	2.1		14.1
Stilbite	(Na ₂ · Ca)Al ₂ Si ₆ O ₁₆ · 6 H ₂ O	V	57.4	16.3	7.7		1.4	17.2
Gismondite	CaAl ₂ (SiO ₃) ₄ · 4 H ₂ O	V	35.88	27.23	13.12	2.85		21.10
Laumontite	H ₄ CaAl ₂ Si ₄ O ₁₄ · 2 H ₂ O	V	51.1	21.7	11.9			15.3
Chabazite	(Ca · Na ₂)Al ₂ (SiO ₃) ₄ · 6 H ₂ O	III	47.4	20.2	11.1			21.3
Gmelinite	(Na ₂ · Ca)Al ₂ (SiO ₃) ₄ · 6 H ₂ O	III	47.96	29.47	0.83	1.87		18.87
Analcite	NaAl(SiO ₃) ₂ · H ₂ O	I	54.5	23.2			14.1	8.2
Faujasite	H ₄ Na ₂ CaAl ₄ (SiO ₃) ₁₆ · 18 H ₂ O	I	46.12	16.81	4.79		5.09	27.02
Edingtonite	Ba ₂ Al ₂ Si ₃ O ₁₀ · 3 H ₂ O	II	36.98	22.63	26.84 BaO			12.46
Natrolite	Na ₂ Al(AIO)(SiO ₃) ₃ · 2 H ₂ O	IV	47.4	26.8			16.3	9.5
Scolecite	Ca(AIOH) ₂ (SiO ₃) ₂ · 2 H ₂ O	V	45.9	26.0	14.3			13.8
Thomsonite	(Na ₂ · Ca)Al ₂ (SiO ₄) ₂ · 2½ H ₂ O	IV	36.8	31.6	8.6		9.5	13.8
Hydronaphelite	HN ₂ Al ₃ (SiO ₄) ₃ · 3 H ₂ O	III	39.3	33.4			13.5	13.8
Rauite	(Na ₂ · Ca)Al ₂ (SiO ₄) ₂ · 2 H ₂ O							

rocks. Their formation takes place at comparatively low temperatures and some even at temperatures near zero, as phillipsite has been found in the volcanic mud at the bottom of the Pacific Ocean.

Zeolites are formed synthetically by heating their constituents in the correct proportions, in each case, in a sealed tube with water, to temperatures between 170° and 250°. In a similar way they are often separated from the percolating waters of many hot springs. Their water content is held with different degrees of firmness; some even lose their water to dry air and reabsorb it without any material physical change. This water is therefore said to take no part in the formation of the crystalline molecule. Zeolites which have had their water driven out at a temperature below redness will not only reabsorb the water from moist air, but will take up in the same way alcohol, ammonia, silicon chloride, and coloring matter. If the zeolite is fused, it loses this property, as the molecule is changed in nature, for from fused natrolite on cooling nepheline is formed; from apophyllite, hexagonal calcium metasilicate; from chabazite, anorthite; from heulandite pyroxene is produced.

The zeolites are so near alike in their occurrence and appearance that unless well crystallized it is difficult to distinguish them, and often a quantitative determination of silica and water is necessary for the identification of species. They all boil when heated in the blowpipe flame, from which the group takes its name.

They are usually associated with datolite, prehnite, pectolite, quartz, calcite and pyrite, or chalcopyrite.

APOPHYLLITE

Apophyllite.— $H_{14}K_2Ca_8(SiO_3)_{16} \cdot 9 H_2O$; a hydrated metasilicate of calcium and potassium; Tetragonal; Type, Ditetragonal Equatorial; $c = 1.2515$; $001 \wedge 101 = 51^\circ 22'$; $001 \wedge 111 = 60^\circ 32'$; Common forms, **a** (100), **c** (001), **m** (110), **p** (111); Twinning plane, 111 rare; Cleavage, basal perfect, **m** less so; Brittle; Fracture, uneven; H. = 4.5–5; G. = 2.3–2.4; white, gray, or pale shades of yellow, green, or red; Streak, white; Transparent to translucent; Luster, vitreous, on the base pearly; $\omega = 1.534$; $\epsilon = 1.536$; $\omega - \epsilon = .002$; Optically (\pm) often showing anomalies.

B.B. — Exfoliates and fuses to a white blebby enamel. Colors the flame violet (potassium) or shows potassium through the blue glass. In the closed tube yields water. Decomposed with HCl without gelatinization. Often shows fluorine.

General description. — Crystals are prismatic or tabular, parallel to the base; less often are they pyramidal. Usually combinations of the base, the unit pyramid of the first order, and the unit prism of the second. The prism face is vertically striated, and the base is often dull.

Apophyllite is a common mineral in the fissures of the traps of the New England and Middle states. Beautiful specimens of stout prismatic habit have been taken from the various railroad cuts through Bergen Hill, New Jersey, where it is asso-



FIG. 501. — Apophyllite with Small Crystals of Albite. Paterson, New Jersey.

ciated with other zeolites, prehnite, pectolite, and datolite. It is also common in the Lake Superior copper region; at Peter's Point, Nova Scotia. Light pink crystals occur at Andreasberg in the Harz, which are pyramidal in habit; also at Aussig in Bohemia, which is a noted European locality for zeolites in general.

HEULANDITE

Heulandite. — $H_4CaAl_2(SiO_2)_6 \cdot 3H_2O$; Monoclinic; Type, Digiagonal Equatorial; $\dot{a} : \dot{b} : \dot{c} = .4035$; $l : .4293$; $\beta = 88^\circ 34' = 001 \wedge 100$; $100 \wedge 110 = 21^\circ 58'$; $001 \wedge 011 = 23^\circ 13'$; $201 \wedge 001 = 63^\circ 40'$; $001 \wedge \bar{2}01 = 66^\circ$; Twinning plane, 100; Common forms, c (001), b (010), m (110), t (201), s ($\bar{2}01$); Cleavage, b perfect; Brittle; Fracture, subconchoidal; H. = 3.5–4; G. = 2.18–2.22; Color, white, gray, brown, or brick-red; Streak, white; Luster, vitreous, on cleavage face pearly; Transparent to translucent; $\alpha = 1.498$; $\beta = 1.499$; $\gamma = 1.505$; $\gamma - \alpha = .007$; Optically (+); Axial plane perpendicular to 010; Bx_1 normal to the ortho-axis; $2V = 0^\circ$ to 90° .

B.B. — Exfoliates and curls, fusing at 2–2.5 to a white enamel. Yields water in the closed tube. Decomposed with HCl without gelatinization, the solution freed from silica yields a precipitate with ammonia (Al), after filtering, the filtrate yields a white precipitate with ammonia carbonate (Ca).

General description. — Crystals are flattened in habit, parallel to **b**, and usually joined along the same face in parallel positions forming ridges, the top of the ridge being the base and the sides the two forms **s** and **t**, which are vitreous in luster, while the strong



FIG. 502. — Heulandite from the Faroe Islands.

pearly luster on **b** is very characteristic. The face **b** is often concave, while **s** and **t** are convex and striated parallel to their intersection with **b**. Sometimes it occurs in globular shapes or granular.

Chemically the calcium in part may be replaced by sodium, potassium, barium, or strontium, when it approaches brewsterite, another very closely related zeolite.

Heulandite is a very common mineral in the trap of Bergen Hill, and in the quarries at Paterson, New Jersey. Red specimens are found in Nova Scotia; Fassathal, in the Tyrol. It also occurs in Iceland and the Faroe Islands.

HARMOTOME

Harmotome. — $\text{H}_2(\text{K}_2, \text{Ba})\text{Al}_2(\text{SiO}_3)_5 \cdot 5 \text{H}_2\text{O}$; Monoclinic; Type, Digonal Equatorial; $\dot{a} : \dot{b} : \dot{c} = .7032 : 1 : 1.2310$; $\beta = 55^\circ 10' = 001 \wedge 100$; $100 \wedge 110 = 29^\circ 59'$; $001 \wedge 101 = 35^\circ 42'$; $001 \wedge 011 = 45^\circ 18'$; Common forms, **c**(001), **b**(010), **a**(100), **m**(110);

Twinning plane the base, penetrating twins common; Cleavage, **b** easy, **c** less so; Brittle; Fracture, uneven; $H. = 4.5$; $G. = 2.44-2.50$; Color, white, gray, yellow, or brown; Streak, white; Luster, vitreous; Translucent to transparent; $\alpha = 1.503$; $\gamma = 1.508$; $\gamma - \alpha = .005$; Optically (+); $Bx_a = \bar{b}$; $Bx_0 \wedge \bar{a} = 60^\circ$ in front.

B.B. — Whitens, crumbles, and fuses at 3.5 to a white, transparent glass. Yields water in the closed tube. Very little affected with HCl; fused with soda and freed of silica and aluminium, the filtrate yields a white precipitate with dilute sulphuric acid (barium).

General description. — Crystals are usually twinned in cross-shaped, interpenetrating, or contact twins, in which the composition face is the base, yielding a crystal orthorhombic in appearance, in which the unit prism **m** appears as if a pyramid face, and the faces **b** and **c** as if prisms. This habit of twinning is also characteristic of other zeolites, as phillipsite and stilbite.

The barium and strontium zeolites are rare and local in their occurrence. In the United States harmotome occurs associated with stilbite in places, in the gneiss of Manhattan Island, New York.

STILBITE

Stilbite. — $(Na_2, Ca)Al_2Si_6O_{15} \cdot 6H_2O$; Monoclinic; Type, Digonal Equatorial; $\bar{a} : \bar{b} : \bar{c} = .7622 : 1 : 1.1940$; $\beta = 50^\circ 50' = 001 \wedge 100$; $100 \wedge 110 = 30^\circ 35'$; $001 \wedge \bar{1}01 = 89^\circ 30'$; $001 \wedge 011 = 42^\circ 47'$; Common forms, **c** (001), **b** (010), **m** (110), **e** (011); Twinning plane, the base penetration twins; Cleavage, basal perfect; Brittle; Fracture, uneven; $H. = 3.5-4$; $G. = 2.1-2.2$; Color, white, gray, yellow, brown, or red; Streak, white; Luster, vitreous, **b** pearly; Transparent to translucent; $\alpha = 1.494$; $\beta = 1.498$; $\gamma = 1.500$; $\gamma - \alpha = .006$; Optically (-); Axial plane, $\perp 100$; $Bx_a \wedge c = 31^\circ 10'$ in front; $2V = 33^\circ$.

B.B. — Exfoliates, curls, and fuses at 2-2.5 to a white enamel. Yields water in the closed tube. Decomposes with HCl without gelatinizing.

General description. — Crystals flattened parallel to 010 and joined by this face in complex bundles of parallel or divergent ag-

gregates, often restricted in the middle or sheaf-like, a form very characteristic of stilbite. Twinning also as in harmotome. When the crystals are tabular and simple, the very strong pearly luster on the orthopinacoid has the appearance of fish scales.

Chemically the calcium may be replaced in part by sodium, and the brown color of some specimens is due to the presence of iron. Stilbite is a common mineral in the cracks of the basic eruptive



FIG. 503.—Stilbite from Nova Scotia.

rocks. Very fine white specimens have been taken from the railroad cuts through Bergen Hill, New Jersey. It is also found in the trap quarries at Moore's Station, New Jersey, where it is associated with natrolite, prehnite, calcite, and pectolite.

Cabinet specimens are obtained at Partridge Island, Nova Scotia and the Lake Superior region.

CHABAZITE

Chabazite. — $(Ca \cdot Na_2)Al_2(SiO_3)_4 \cdot 6 H_2O$; Hexagonal; Type, Dihexagonal Alternating; $c = 1.0860$; $0001 \wedge 10\bar{1}1 = 51^\circ 26'$; $\bar{1}011 \wedge 1011 = 85^\circ 14'$; Common forms, $r(10\bar{1}1)$, $e(0112)$, $s(0\bar{2}21)$; Twinning axis c , interpenetration twins; Cleavage, rhombohedral distinct; Brittle; Fracture, uneven; $H. = 4.5$; $G. = 2.08-2.16$; Color, white, yellow, gray, flesh-red, or pink; Streak, white;

Luster, vitreous; Transparent to translucent; $n = 1.46$; $\omega - \epsilon = .002$; Optically (\pm) depending upon the amount of water.

B.B. — Intumesces and fuses easily to a blebby glass. Yields water in the closed tube. Decomposes with HCl, yielding slimy silica.

General description. — Crystals are simple rhombohedrons, nearly cubical in appearance, but the angle is 85° ; or combinations of r and e with striations on both forms parallel to their intersections. Interpenetrating twins in which the vertical axis is the



FIG. 504. — Chabazite. Swan's Point, Nova Scotia.

twinning axis are common. Upon the whole chabazite has very much the appearance of fluorite, also granular or amorphous.

Chemically the calcium and sodium content is variable, and they replace each other, and at times barium, strontium, or iron may enter the molecule.

Chabazite in its occurrences is associated with the other zeolites and under the same conditions. Good specimens are obtained at Bergen Hill, New Jersey; at various points in Nova Scotia; as well as at the noted zeolite localities of Europe, as the Giant's Causeway, Faroe Islands, Iceland, and Aussig.

ANALCITE

Analcite. — $\text{NaAl}(\text{SiO}_3)_2 \cdot \text{H}_2\text{O}$; Isometric; Type, Ditesseral Central; Common forms, n (211) other forms, as a (100) and d (110), rare; Cleavage, cubic in traces; Brittle; Fracture, subconchoidal;

H. = 5-5.5; G. = 2.22-2.29; Color, white with various tints, especially reddish; Streak, white; Luster, vitreous to nearly opaque; $n = 1.487$.

B.B. — Fuses easily to a colorless glass, gelatinizes with HCl. Yields water in the closed tube.

General description. — Crystals simple tetragonal trisoctahedrons; rarely is it in combination with the cube or the rhombic



FIG. 505. — Tetragonal-trisoctahedron of Analcite, from Fassathal, Tyrol.

dodecahedron. Like leucite, these individual crystals may be complexes, and the outward form is only pseudo-isometric, also massive.

Analcite is formed in many instances as pseudomorphs after leucite, by an interchange of alkalis and hydration; it is also formed from sodalite and nepheline.

Analcite is one of the more common zeolites and occurs in rocks containing sodalite, nepheline, or leucite, as a secondary mineral, as well as in the cracks and cavities of the traps, diorites, and

basalts. It is found at Bergen Hill and Princeton, New Jersey; in the Lake Superior region; Golden, Colorado; various points in Nova Scotia; and in Europe, in the Fassathal, Tyrol; Aussig, Bohemia; Andreasberg, Harz; Faroe Islands and Iceland.

NATROLITE

Natrolite. — $\text{Na}_2(\text{AlO})\text{Al}(\text{SiO}_3)_3 \cdot 2\text{H}_2\text{O}$; Orthorhombic; Type, Didigonal Equatorial; $\bar{a} : \bar{b} : \bar{c} = .9785 : 1 : .3536$; $100 \wedge 110 = 44^\circ 23'$; $001 \wedge 101 = 19^\circ 52'$; $001 \wedge 011 = 19^\circ 28'$; $110 \wedge 111 = 63^\circ 11'$; Common forms, m (110), o (111), b (010), c (001); Cleavage, prismatic perfect, b imperfect; Brittle; Fracture, uneven; H. = 5-5.5; G. = 2.20-2.25; Color, white, gray, yellow, or reddish; Streak, white; Luster, vitreous; Transparent to translucent; $\alpha = 1.475$; $\beta = 1.478$; $\gamma = 1.488$; $\gamma - \alpha = .013$; Optically (+) Axial plane = 010; $\text{Bx}_a = \bar{c}$; $2V = 61^\circ 56'$.

B.B. — Fuses at 2 to a colorless glass. Yields water in the closed tube. Gelatinizes with HCl; the solution freed of silica and aluminium yields little or no precipitate with ammonium carbonate (calcium).

General description. — Long prismatic in habit, the individual crystals are combinations of nearly a square prism terminated by the unit pyramid, tetragonal in appearance; except for the occurrence of the brachypinacoid, as in case of the specimens from San-

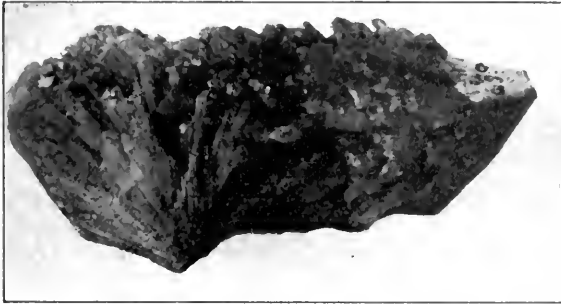

FIG. 506. — Natrolite. Aussig, Bohemia.

doen, Norway. Often in long acicular crystals joined in spherical or divergent masses with the free end terminated; in this habit, it is very similar to pectolite, mesolite, and thomsonite. Also granular but rarely massive, as that in which the neptunite and benitoite is imbedded, occurring in San Benito County, California.

Natrolite occurs filling amygdaloid cavities and cracks in basalt and other related igneous rocks, as at Bergen Hill; Moore's Station, New Jersey; at various points in Nova Scotia and Magnet Cove, Arkansas.

THOMSONITE

Thomsonite. — $(\text{Na}_2\text{Ca})_2\text{Al}_2(\text{SiO}_4)_2 \cdot 5\text{H}_2\text{O}$; Orthorhombic; Type, Didigonal Equatorial; $\tilde{a} : \tilde{b} : \tilde{c} = .9932 : 1 : 1.0066$; $100 \wedge 110 = 44^\circ 48'$; $001 \wedge 101 = 44^\circ 37'$; $001 \wedge 011 = 45^\circ 11'$; $001 \wedge 111 = 55^\circ$; $001 \wedge 012 = 26^\circ 43'$; Common forms, *a* (100), *m* (110), *c* (001), *d* (401), *p* (111); Cleavage, *b* perfect, *a* less so; Brittle; Fracture, uneven; H. = 5–5.5; G. = 2.5–3.4; Color, white, reddish to brown; Streak, white; Transparent to translucent; $\alpha = 1.497$; $\beta = 1.503$; $\gamma = 1.525$; $\gamma - \alpha = .028$; Optically (+); Axial plane = 001; $\text{Bx}_4 = \tilde{b}$; $2V = 53^\circ 50'$.

B.B. — Intumescens and fuses at 2 to a white enamel; yields water in the closed tube. Gelatinizes with HCl; the solution freed of silica and aluminium yields a white precipitate with ammonium carbonate (calcium).

General description. — Simple individual crystals are rare, usually elongated and joined with their vertical axis parallel or in radiated and divergent groups, resembling pectolite and natrolite. The free ends of the long acicular crystals are usually terminated by the base and not by the pyramid, as in natrolite. It also occurs nodular, concretionary, or massive; comptonite is a massive variety filling amygdaloid cavities of the lavas on Monte Somma, Vesuvius. A radiated variety found filling cavities in a rock at Grand Marais, Lake Superior, is known as lintonite. It is often polished and used for buttons and small ornaments, showing concentric rings of green, red, and white. Much of this material is gathered on the beach of Lake Superior, as water-worn pebbles.

Thomsonite occurs associated with other zeolites at the various points in Nova Scotia; at Kaden, Bohemia; Kilpatrick, Scotland; Schneeberg, Saxony. It is rare at the zeolite localities in New Jersey, but recently identified at Paterson. It is associated with other zeolites at Magnet Cove, Arkansas, and Table Mountain, near Golden, Colorado.

MICAS

Muscovite	$H_2KAl_3(SiO_4)_3$.
Paragonite	$H_2NaAl_3(SiO_4)_3$.
Biotite	$HK(Mg, Fe)_2Al_2(SiO_4)_3$.
Phlogopite :	$H_2KMg_3Al(SiO_4)_3$.
Lepidomelane	A phlogopite rich in iron.
Lepidolite	$H_2KAl_3(SiO_4)_3 + R'_3AlF_2Si_3O_8$.
Zinnwaldite	Is a lepidolite with magnesia and iron.

The above list includes the most important species of micas, but between these are varieties representing substitution products and mixtures of the two molecules of ortho- and tri-silicates, in various proportions, as their compositions vary considerably.

Chemically the micas are mostly orthosilicates, substitution products derived from the general formula $Al_4(SiO_4)_3$, in which the substitution replaces one or more of the aluminium atoms. In muscovite one of the Al atoms is replaced by H_2K , yielding the formula

$H_2KAl_3(SiO_4)_3$. In paragonite H_2Na takes the place of one Al, in biotite $HK(Mg, Fe)_2$ is substituted for two Al, and in phlogopite H_2KMg_3 takes the place of three Al. In all the species hydrogen appears as one element, either as basic or acid, and therefore all micas yield water at a high temperature. Their formation in nature must be a hydrothermal reaction under pressure. Mixed with the orthosilicate in some species is a trisilicate ($H_4Si_3O_8$), and when this appears in sufficient amounts the percentage of silica may be that of a metasilicate, as in lepidolite.

They are all monoclinic and assume a pseudohexagonal symmetry, as the angle of the unit prism is 120° , which in combination with the pinacoid yields a basal section of hexagonal outline, parallel to which is the characteristic perfect basal cleavage known as micaceous.

MUSCOVITE

Muscovite. — A potash mica; $H_2KAl_3(SiO_4)_3$; $K_2O = 11.8$; $Al_2O_3 = 38.5$; $SiO_2 = 45.2$; $H_2O = 4.5$; Monoclinic; Type, Digonal Equatorial; $\hat{a} : \hat{b} : \hat{c} = .5773$; $1 : 3.3128$; $\beta = 89^\circ 54' = 001_\lambda 100$; $100_\lambda 110 = 30'$; $001_\lambda 101 = 80^\circ 12'$; $001_\lambda 011 = 73^\circ 12'$; $001_\lambda 221 = 85^\circ 36'$; Common forms, c (001), m (110), b (010); Twinning plane, 110; Cleavage, basal micaceous; Laminae flexible, elastic, and tough; $H. = 2-2.5$; $G. = 2.76-3$; Color, gray and shades of brown, green, rarely red; Streak, white; Luster, vitreous; Transparent to translucent; $\alpha = 1.557$; $\beta = 1.587$; $\gamma = 1.590$; $\gamma - \alpha = .038$; Optically (-); Axial plane $\perp 010$; $Bx_a \perp$ to the base; $2V = 64^\circ-72^\circ$.

B.B. — Fuses quietly at 5.5. Yields some water in the closed tube. Not decomposed with sulphuric acid.

General description. — Crystals are short, stout prisms or tabular combinations of the prism, base, and brachypinacoid, pseudo-hexagonal in section and outline. Cleavage laminae yield percussion figures indicating a secondary cleavage or a parting. If a blunt-pointed instrument is placed on a cleavage piece of muscovite and struck a sharp blow, a six-pointed star will be produced at the point of contact, formed by the intersection of three straight cracks intersecting each other at an angle of 60° . The cracks are parallel to the six sides of the basal section, and the crack parallel to the brachypinacoid is more developed or larger than the other two, indicating the monoclinic nature of the mineral; for if it were hexag-

onal, all three should be interchangeable. On the other hand, the figure produced by pressure, or pressure figure, will have the three lines at right angles to the sides of the basal section. Inclusions,



FIG. 507. — Muscovite Crystals from Woodstock, Maine.

often oxides of iron, in micas are, in numerous instances, symmetrically arranged along lines intersecting at 60° , thus forming equilateral triangles, the sides of which are parallel to the rays of the above figures, — more often to the rays of the pressure figure. In some cases both sets may be present.

The chemical composition of muscovite varies greatly from the

formula given above, as some of the potassium may be replaced by sodium, lithium, or caesium, while the hydrogen is replaced by fluorine, and all micas contain small amounts of fluorine. Aluminium is at times replaced by chromium, as in the green chrome mica, fuchsite, of Pfitsch, Tyrol; or again by vanadium, as in roscoelite, a vanadium mica occurring in some of the gold-bearing veins of California. Ferric iron may also take the place of aluminium, yielding varieties of dark color.

Both composition and physical texture are taken into account in separating the micas into species and varieties, which in some cases may be only artificial distinctions, as it is possible that they, like the plagioclase feldspars, are isomorphous mixtures of various salts which have not been definitely determined; if so, they should in their composition grade into each other with no sharp line of demarcation.

In rock sections muscovite is of an irregular outline. When cut parallel to the vertical axis, the sections show fine parallel cleavage cracks, very close together; the relief in this section is high, and the interference colors are of the second or third order. When the section is parallel to the base or cleavage, there are no cracks or relief, and the interference color is a gray of the first order, and as the cleavage is only slightly inclined to the acute bisectrix, the inter-

ference figure is symmetrical in the field showing well-defined dark shadows, but in thin sections no color bands. Pleochroism is not marked, but absorption takes place in those sections containing cleavage cracks and is the strongest in sections parallel to the vertical axis and parallel to the cleavage cracks, which is the reverse of that found in tourmaline, where absorption is the strongest parallel to the vertical axis.

Muscovite is a common primary mineral of granites, syenites, and pegmatites, and usually separates from the magma directly after zircon, apatite, and magnetite and before the feldspars. It is particularly characteristic of pegmatites, in which the sheets may be of enormous size, as in the Black Hills, where sheets a yard across have been found.

It is also widely distributed in the schists and gneisses, where the scales are parallel in position and, in the variety sericite, very small and silky in appearance. As a secondary mineral it is a product derived from the alteration of numerous aluminium silicates, as the feldspars, andalusite, cyanite, scapolite, nepheline, and also from corundum. Muscovite itself is very stable under the conditions of weathering, persisting in an exceptionally fresh condition in the residual products of such rocks as granite and syenite, long after other minerals have succumbed to oxidation or kaolinization. Under the influence of hot aqueous solutions and pressure, the reactions above may be reversed, and muscovite will be transformed to leucite, nepheline, or feldspars. The complex nature of micas is demonstrated on fusion, for then they break down on cooling to various products, among which, in case of muscovite, are leucite, sillimanite, glass, and water.

Commercially muscovite is mined in the pegmatites of the Black Hills, South Dakota; along the Blue Ridge in North and South Carolina, Virginia, and Georgia; at Cañon City, Colorado, while several other states are producers of small quantities. The product of sheet mica in the United States is about one million pounds annually.

The micas, especially muscovite, are used for many purposes, when in large sheets, as for stove doors and lamp chimneys and shades. The value varies greatly with the size of the sheets. Fragmental mica is used as an insulator in various electric apparatus, and when finely ground it is used as a paint for frosting, and, as in the case of graphite, as a lubricant.

The synthetic production of mica is uncertain. Biotite has been

produced by the fusion of a mixture of KAlSiO_4 and Mg_2SiO_4 with fluorides; by a variation of the components, phlogopite, zinnwaldite, and muscovite have also been produced, but none of these artificial products contains hydrogen, which all natural micas do. Micas have been found as a crystalline product in some furnace slags.

BIOTITE

Biotite. — $\text{HK}(\text{Mg} \cdot \text{Fe})_2\text{Al}_2(\text{SiO}_4)_3$; $\text{K}_2\text{O} = 11.21$; $(\text{Mg} \cdot \text{Fe})\text{O} = 19.21$; $\text{Al}_2\text{O}_3 = 24.35$; $\text{SiO}_2 = 43.08$; $\text{H}_2\text{O} = 2.14$; Monoclinic; Type, Digonal Equatorial; $\mathbf{a} : \mathbf{b} : \mathbf{c} = .5774 : 1 : 3.2743$; $\beta = 90^\circ = 001 \wedge 100$; $100 \wedge 110 = 30^\circ$; $001 \wedge 101 = 80^\circ$; $001 \wedge 011 = 73^\circ 1'$; $001 \wedge 221 = 85^\circ 38'$; Common forms, \mathbf{c} (001), \mathbf{b} (010), \mathbf{M} (221), \mathbf{r} (101), \mathbf{o} (112); Twinning plane, 110; Cleavage, basal perfect; Laminae, flexible, elastic, and tough; $\text{H.} = 2.5\text{--}3$; $\text{G.} = 2.7\text{--}3.1$; Color, greenish black to black in thick crystals; Streak, colorless; Luster, splendid, transparent to translucent; $\alpha = 1.504$; $\beta = 1.589$; $\gamma = 1.589$; $\gamma - \alpha = .085$; Optically (—); Axial plane $\perp 010$ or $\parallel 010$; $\mathbf{Bx}_a \perp 001$; $2\mathbf{V} = 0\text{--}40^\circ$.

B.B. — Whitens and fuses, some with difficulty, while specimens with much iron fuse easily and become magnetic. In the closed tube yields water. Decomposes with sulphuric acid without gelatinizing.

General description. — In crystalline habit twinning and cleavage like muscovite.

Chemically biotite differs from muscovite in that two atoms of aluminium have been replaced by magnesium and iron. Ferric iron may replace the Al in part; lepidomelane is a black mica rich in both ferrous and ferric iron.

In rock sections biotite is brown, greenish, or reddish, rarely with distinct outline. Pleochroism very marked, increasing with the depth of color; the absorption is the strongest with the ray vibrating parallel to the cleavage cracks. Relief is high in those sections in which the cleavage cracks appear, and is very low in the basal section, in which the indices of refraction are but little above that of Canada balsam. Interference colors in sections parallel to the vertical axis are high, but in the basal section where the two indices are so nearly equal, the section reacts like a uniaxial crystal, appearing as if dark during a complete revolution. The plane of the optic axes varies in its position from perpendicular to the plane

of symmetry, 010, in muscovite, paragonite, lepidolite, or the alkali micas, and some biotites, termed anomites, to parallel to the plane of symmetry in most biotites, phlogopite, zinnwaldite, and lepidomelane. The former are the micas of the first class, while the latter are the micas of the second class. The angle between the



FIG. 508. — Biotite Crystals from Franklin, New Jersey.

optic axes in some cases is so near zero that biotite for a long time was thought to be hexagonal, but $2V$ may vary from 0, to in some cases nearly 60° .

Biotite is probably the most common of all the micas, occurring as a primary mineral in such rocks as granite, syenite, diorites, and the basaltic igneous rocks, in which latter muscovite is rare. It separates from the magma early, crystallizing before the feldspars, and in some cases is intergrown with other species forming crystals of zonal structure, in which the central portion will be the more magnesian varieties of phlogopites, while the alkali micas form the outer zone. In this way lepidolite often forms the outer zone of muscovite. Biotite is also of metamorphic origin, as in the gneisses and schists, as well as in the sedimentary rocks. As a secondary mineral it is not formed from the material furnished by the alteration of a single mineral, as is the case of the feldspars and muscovite,

but by double decomposition and precipitation from solution of materials furnished by magnetite and feldspars or amphibole as an illustration.

Owing to its iron content, biotite is much easier decomposed by weathering and oxidation than muscovite, the first step in which seems to be the absorption of water, or hydration, and loss of alkali, forming hydrobiotite or vermiculite, $H_2Mg_3Al_2(SiO_4)_3 \cdot 3 H_2O$. The second step is the formation of chlorite, $H_2(MgOH)_4Al_2(SiO_4)_3$ by further hydration, in which the water becomes more firmly attached to the molecule. When the biotite is rich in iron, magnetite is a

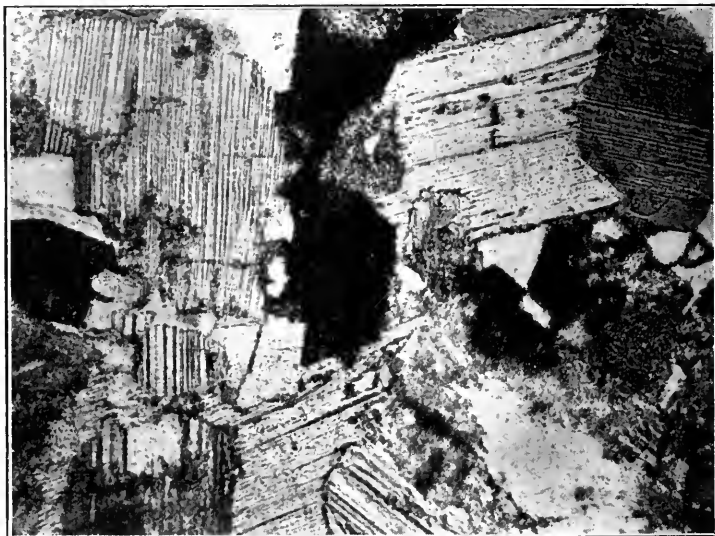

FIG. 509. — Biotite and Muscovite in a Section of Augite-syenite, between Crossed Nicols. The Dark Areas are Dark Brown Biotite, Parallel to the Cleavage. The Fine Striations are Traces of the Micaceous Cleavage.

product. A large number of minerals have been described as derived from biotite, as epidote, serpentine, kaolinite, gibbsite, etc.

Biotite when fused loses its water and breaks down, forming olivine, leucite, spinel, and glass. Its synthesis is as in muscovite.

PHLOGOPITE

Phlogopite. — Magnesian mica, $H_2KMg_3Al(SiO_4)_3$; $K_2O = 8.40$, $MgO = 28.90$, $Al_2O_3 = 10.87$, $SiO_2 = 44.81$, $H_2O = 5.42$, with a little iron, sodium, and fluorine; Monoclinic; Type,

Digonal Equatorial; Crystalline elements and habit like biotite; Cleavage, basal perfect, micaceous, laminae tough and elastic; $H. = 2.5-3$; $G. = 2.78-2.85$; Color, yellowish brown, with metallic-like reflections, also greenish to nearly colorless; Streak, white; Luster, pearly; Transparent to translucent; $\alpha = 1.562$; $\beta = 1.606$; $\gamma = 1.606$; $\gamma - \alpha = .044$; Optically (-); Axial plane = 010; $Bx_a \perp$ to 001; $2E = 0-40^\circ$.

B.B. — Whitens and fuses on the thin edges. Generally yields no iron reactions with the fluxes. Decomposes with sulphuric acid, leaving the silica in thin flakes. In the closed tube yields some water.

General description. — In rough, six-sided crystals, which are, however, better formed than in biotite.

It occurs, as a product of metamorphism, in the crystalline limestones and dolomites, as at Gouverneur, New York; Newton, New Jersey; Franklin, New Jersey; and various other localities in the Middle States and Ontario. Crystals from Sydenham, Ontario, measure five or six feet across the base.

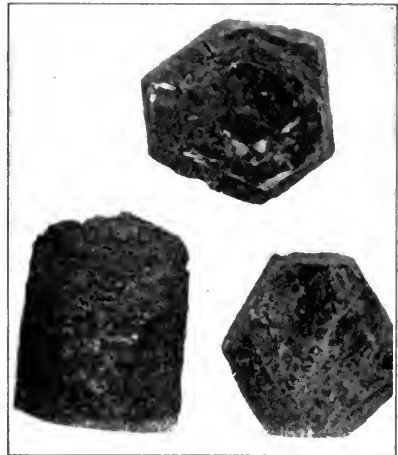

FIG. 510.—Phlogopite. Rossie, New York.

In decomposition it resembles biotite, and commercially it finds the same uses as muscovite.

LEPIDOLITE

Lepidolite. — Lithia mica, $H_2KAl_3(SiO_4)_3 \cdot R_3AlF(Si_3O_8)$; Monoclinic; Type, Digonal Equatorial; Crystalline elements and form as in muscovite; Cleavage, basal perfect, micaceous laminae flexible, elastic, and tough; $H. = 2.5-4$; $G. = 2.8-2.9$; Color, pale pink, violet, gray, or yellowish; Streak, colorless; Luster, pearly; Transparent to translucent; $\beta = 1.597$; $\gamma = 1.605$; $\gamma - \beta = .008$; Optically (-); Axial plane \perp to 010; $Bx_a \wedge c = 5^\circ$; $2E = 57^\circ-85^\circ$.

B.B. — Intumescens and fuses at 2.5 to a blebby glass, yielding a lithium flame, especially when mixed with the potassium bisulphate flux. Only slightly attacked by acids.

General description. — Crystals are small tabular or scaly aggregates or massive. Chemically it approaches the formula of a metasilicate, or it may be a mixture of the ortho- and trisilicate as the formula given would indicate, in which R' represents lithium and small amounts of rubidium and caesium; as with all micas, fluorine is present.

Polyolithionite is a lepidolite from Greenland, in which the silica is in the proportion of a metasilicate. Zinnwaldite is a lithia mica, found in the tin veins of Bohemia, containing considerable iron.

Lepidolite occurs in pegmatites or granitic veins associated with tourmaline, spodumene, amblygonite, beryl, cassiterite, feldspars, biotite, and quartz, often intergrown with the biotite forming the margins of the plates.

In the United States it occurs at Hebron and Paris, Maine, and at various points in Massachusetts and Connecticut; at the rubellite locality in San Diego County, California.

In weathering it hydrates and probably forms cookeite, which is associated with it at Paris and Hebron, Maine, and at Chesterfield, Massachusetts.

CLINTONITE GROUP

The clintonites or brittle micas are foliated micaceous minerals in which the alkalis of the true micas are wanting and the magnesia is in large part replaced by iron and calcium; manganese may also enter the molecule. They are all basic and more complex in their nature and chemical composition. Their formula may be expressed $R_3R''R'''O_2(SiO_4)$ or $R_3R''R'''O_2(Si_3O_8)$ or a mixture of the two, in which R''' is either aluminium or ferric iron, R'' is Fe, Ca, Mn, or Mg, and R' is H, OH, or F. They are all easily altered by hydration, and it is difficult to determine whether the specimen represents the true and unaltered composition or not, — another difficulty in the way of expressing a formula.

Margarite, $H_2CaAl_4Si_2O_{12}$, a calcium mica, associated with corundum, from which it is often derived as a secondary product. It has a hardness of 3.4–4.5, $G. = 2.99$; Color, pink, gray, or yellow; Luster, pearly.

B.B. — Fuses on the thin edges, yields water in the closed tube. Crystals are rare. It is found associated with staurolite and

tourmaline in schists at Chester, Massachusetts; also at Unionville, Pennsylvania, and at the corundum localities of North Carolina and Georgia.

Ottrelite, $H_2(Fe.Mn)Al_2Si_2O_9$, is a mica in which there is considerable manganese; $H. = 6-7$; $G. = 3.3$. It fuses with difficulty and yields iron and manganese reactions and is usually dark gray to black.

Clintonite is a bronze-colored mica occurring at Amity, New York.

CHLORITES

The composition of the chlorites is complex and uncertain. They are all hydrated decomposition products, probably formed of mixtures of several isomorphous salts or types of salts, but just what these types are is still unknown. When fused, their water is driven off and they break down into a portion which is soluble, and into an insoluble portion, of the nature of spinel. They may be derived from the hydration and alteration of almost any ferromagnesian mineral containing aluminium, as they are all basic orthosilicates of aluminium and ferrous iron. Some ferric iron may replace the aluminium, and isomorphous elements replace the ferrous iron, as manganese. When crystallized, they are monoclinic in symmetry, tabular and six-sided in habit, with a perfect basal cleavage. The laminae are flexible and tough, but inelastic. Their color is usually shades of green, as the name implies, except where manganese is present, when they may be pink; $H. = 1-3.5$; $G. = 2.65-2.96$; Double refraction .001 to .009; Optically (\pm); $Bx_a \wedge c = 0-8$.

B.B. — They whiten and fuse on the edges to a black slag when much iron is present, or a yellowish slag when it is absent. Yield much water in the closed tube, about 12 per cent.; decomposed by sulphuric acid.

Clinochlore, $H_8(Mg.Fe)_5Al_2Si_3O_{18}$, and orochlorite (ripidolite) $H_{40}(Mg.Fe)_{23}Al_{14}Si_{13}O_{90}$, are well-crystallized members of the group, occurring in large hexagonal plates or curiously curved prisms. Their crystals are often implanted on the edges in divergent groups. They yield pressure and percussion figures as in the true micas. Large rough crystals of clinochlore occur at West Chester, Pennsylvania, and well-formed tabular crystals at Texas, Pennsylvania.

Corundophilite, $H_{20}(Mg \cdot Fe)_{11}Al_8Si_6O_{45}$, is associated with corundum at Chester, Massachusetts, and Asheville, North Carolina. Thuringite is a massive scaly variety occurring at French Creek, Pennsylvania; Hot Springs, Arkansas; and at Harper's Ferry inclosing garnets.

Stilpnomelane is an iron variety having the metallic luster of brass or mosaic gold, occurring at the Sterling iron mine, New York.

Some fifteen other species and varieties could be added, most of which are rare or uncertain.

Chlorites occur as schist-forming minerals, and lining cavities or filling veins in all kinds of igneous rocks, as alteration products. Most schist-forming chlorites are fine and scaly, having a talclike or soapy feeling; but chemically they are easily distinguished, as chlorite contains much aluminium.

SERPENTINE

Serpentine. — $H_4Mg_3Si_2O_9$, or $H_3Mg_2(Mg \cdot OH)(SiO_4)_2$; $MgO = 43.52$, $SiO_2 = 43.16$, $H_2O = 13.32$; Monoclinic, never in crystals; Cleavage, basal sometimes distinct; $H. = 2.5-5.5$; $G. = 2.50-2.65$; Color, shades of green and yellow; Fracture, conchoidal or splintery; Streak, white; Luster, dull to resinous, or greasy; feels smooth or greasy; Translucent to opaque; $\alpha = 1.560$; $\beta = 1.570$; $\gamma = 1.571$; $\gamma - \alpha = .011-.013$; Optically (-); Chrysotile (+); Axial plane (?); $Bx_a = c$, In chrysotile, $\perp c$; $2V = 16^\circ-98^\circ$.

B.B. — Fuses with difficulty on very thin edges. In the closed tube yields water. After ignition with cobalt solution usually flesh-colored (Mg); decomposes with HCl without gelatinization; the solution freed of silica yields little or no precipitate with ammonia (Al) (those containing iron will yield a brown precipitate); the filtrate tested with sodium phosphate shows magnesium.

General description. — Massive with a microscopic fibrous or felted structure, also foliated or slaty. Chemically serpentine is a basic orthosilicate, which when fused breaks down to olivine and enstatite. Iron may replace the magnesium to as much as seven per cent. and also manganese or nickel in small quantities. It is in all cases a secondary product formed by the weathering and hydration of a large number of minerals; in fact, any silicate containing considerable magnesium may form serpentine. It is especially derived from the weathering of olivine, tremolite, and

enstatite; large masses of serpentine, often impure, result from the alteration of rocks containing these minerals. Magnesium silicates yield much of their associated bases, as calcium and iron, to percolating water containing carbon dioxide, as bicarbonates, the magnesium remaining behind in the basic form as serpentine. Pseudomorphs of serpentine after such minerals as olivine, amphibole, and pyroxene result from this method of alteration. Magnesium may also be carried in solution by the percolating waters as a bicarbonate, which will replace calcium or iron in silicates, again forming serpentine; pseudomorphs formed by this method after minerals which contain no magnesium, as the feldspars and even quartz, are common.

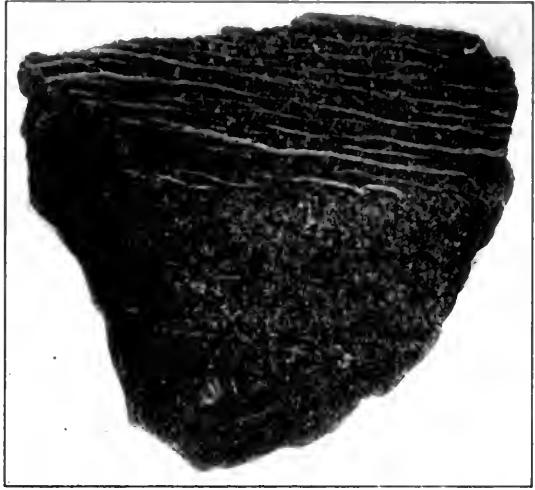

FIG. 511. — Serpentine with Veins of Fibrous Chrysotile. Vernon, New York.

Serpentine is itself decomposed by percolating waters, especially those of solfataric origin, yielding its magnesium as a sulphate or carbonate, leaving the silica free as quartz or opal. Brucite is also a product of the decomposition and hydration of serpentine.

From the many sources from which it may be derived serpentine is necessarily a very widely distributed mineral. It occurs in large bodies, and associated with it in many instances are deposits of chromite and nickel ores, as at Bare Hill, Maryland, and Texas, Lancaster County, Pennsylvania.

Massive serpentine is quarried as a building stone, and when polished is known in the trade as serpentine marble. When mixed with carbonates, which it often is, it forms the mottled green "verdi antique." Serpentine is often disseminated through dolomites, where it has arisen from the alteration of contained silicates rather than from the magnesium of the carbonates.

The variety chrysotile commercially known as asbestos is fibrous and occurs in cross-fibred veins in massive serpentine. When the fibers are soft, silky, and easily separable, they are spun and woven into fireproof cloth. The poorer qualities are used for fireproofing and as non-conductor coverings for steam boilers and pipes.

Chrysotile is mined at Black Lake, Thetford, Quebec; in the United States at Casper, Wyoming, and in northern Vermont near the Canada locality. Closely related to serpentine is the silicate of nickel, **genthite**, $H_4Mg_2Ni_2(SiO_4)_3 \cdot 4H_2O$; as bright green or yellowish green, amorphous crusts, or stalactitic, associated with chromite and serpentine, at Texas, Pennsylvania, and Webster, North Carolina. It is a secondary mineral derived from the serpentine. Usually contains about 30 per cent. of NiO.

Garnierite, also a green amorphous silicate of nickel and magnesium, $H_2(Ni.Mg)SiO_4$, is associated with serpentine at Webster, North Carolina, and at Riddle, Oregon. In New Caledonia it occurs in quantities sufficient to be worked as an ore of nickel.

TALC

Talc. — A basic metasilicate of magnesium, $H_2Mg_3(SiO_3)_4$; MgO = 31.7, SiO₂ = 63.5, H₂O = 4.8; Orthorhombic or monoclinic, well-developed crystals are not known; Cleavage, basal; H. = 1-1.5; G. = 2.7-2.8; Color, gray, or shades of green and yellow; Streak, white; Luster, pearly to greasy; Subtranslucent to opaque; $\alpha = 1.539$; $\beta = 1.589$; $\gamma = 1.589$; $\gamma - \alpha = .050$; Optically (-); Axial plane = 100; $Bx_a \perp 001$; $2E = 6^\circ-40^\circ$.

B.B. — Whitens, exfoliates somewhat, and fuses with difficulty on the very thin edges. Ignited in the forceps with cobalt solutions becomes flesh-colored (Mg). Insoluble in acids.

General description. — Usually massive, granular, or foliated, rarely does it occur in six-sided scales. The massive variety is known as soapstone or steatite. Rensselaerite is a fibrous variety, pseudomorphous after enstatite or amphibole, preserving the structure of the parent mineral.

Chemically, small amounts of iron or nickel may replace the magnesium. Talc is the end product, produced in the weathering of a large number of silicates containing magnesium, especially amphiboles and pyroxenes and often spinel. It is very stable under conditions of weathering, but when fused it loses water and on cooling forms enstatite and quartz.

Like serpentine, owing to the many sources from which it may originate, it forms pseudomorphs after a large number of minerals, and even after species which contain no magnesium, as quartz, topaz, and cyanite, where the magnesium is furnished by percolating waters.

Talc is an abundant mineral, occurring under the same conditions as the chlorites or serpentine; it forms a large proportion of some schists, which are termed talcose schists. It is also found as lenticular masses in metamorphic rocks, and magnetite, chromite, hornblende, serpentine, and chlorites are associated minerals.

Sepiolite (meerschaum), $H_4Mg_2Si_3O_{10}$, is a magnesium silicate closely related to talc. Commercially talc finds many and varied uses; in the powdered form it is used as a paper filler; in toilet powders, paints, lubricants, and soaps. In slabs it is used in the manufacture of hearthstones, table tops, vats, ovens, furnace linings, stair treads, etc.

All the Atlantic coast states are commercial producers of talc. The fibrous variety is only found at Gouverneur, New York.

KAOLINITE

Kaolinite. — Clay; A basic orthosilicate of aluminium, $H_4Al_2Si_2O_9$; $Al_2O_3 = 39.5$, $SiO_2 = 46.5$, $H_2O = 14.0$; Monoclinic; Type, Digonal Equatorial; $a : b : c = .5748 : 1 : 1.5997$; $\beta = 83^\circ 11' = 100 \wedge 001$; $100 \wedge 110 = 29^\circ 43'$; $001 \wedge 101 = 76^\circ 22'$; $001 \wedge 011 = 57^\circ 48'$; Common forms, $b(010)$, $c(001)$, $m(110)$, $n(111)$; Twins as in mica; Cleavage, basal perfect, flexible, inelastic, plastic, and unctuous; $H. = 1-2.5$; $G. = 2.6-2.65$; Color, when pure, white, otherwise yellow, brown, red, or bluish; Streak, white or pale; Luster, pearly to dull; Transparent scales to translucent; $n = 1.54$; $\gamma - \alpha = .008$; Axial plane $\perp 010$; $Bx_a \perp 001 = 20^\circ$ behind; $2E = 0^\circ-90^\circ$.

B.B. — Infusible, becomes blue with cobalt solution. Yields water in the closed tube and a silica residue in the S. Ph. bead. Insoluble in acids.

General description. — In microscopic six-sided scales with angles of nearly 120° ; also friable, mealy, or massive. When wet it is plastic and has a peculiar greasy feel. When dry it absorbs moisture from and sticks to the tongue and emits a peculiar argillaceous odor just after being moistened.

Kaolinite represents the ultimate product in the weathering and hydration of a long series of aluminium silicates. The most important source is in the alteration of the feldspars, known as kaolinization, which is the result of percolating waters charged with carbon dioxide. This is especially true of the alkali feldspars, as anorthite does not form kaolin. The potassium is yielded as a carbonate, leaving the aluminium silicate in the hydrated form as kaolin. It is therefore a secondary mineral widely distributed in all rocks which have suffered alteration and in all soils. It forms pseudomorphs after many minerals, or remains behind mixed with other products of weathering, to form the soils; or it is carried by running water and deposited as sedimentary beds, some of which are very pure kaolin. Owing to the extreme fineness of the scales, they remain longer in suspension, and are deposited apart from heavier and coarser materials.

Clay is a large component of all sedimentary rocks except the sandstones and carbonates. Under ordinary conditions of weathering it is extremely stable and is not broken down, but under the influence of heat and pressure it is dehydrated, yielding its alumina and silica for the formation of minerals characteristic of metamorphic sediments.

Allophane, $\text{Al}_2\text{SiO}_5 \cdot 5 \text{H}_2\text{O}$, is an amorphous aluminium silicate forming mammillary crusts and stalactites. Hardness 3, harder than kaolin, and gelatinizes with HCl.

Pyrophyllite, $\text{H}_2\text{Al}_2\text{Si}_4\text{O}_{12}$, is a silicate of aluminium resembling talc in appearance, as to color, structure, luster, and feeling. It may also be radiated and fibrous as well as massive, but when heated it swells many times its volume and becomes blue when ignited with cobalt solution.

There are other silicates of aluminium related to kaolinite, some of which are probably mixtures, and the composition of others is uncertain.

Commercially clay or kaolinite is the basis of all porcelain and chinaware, and the impure varieties are used in the manufacture of tile, drainpipes, and bricks.

The purer varieties are obtained in Chester and Delaware Counties, Pennsylvania, and in North Carolina, while a large proportion of the ordinary clays is dug in New Jersey.

CHRYSOCOLLA

Chrysocolla. — A hydrous metasilicate of copper, $\text{CuSiO}_3 \cdot 2\text{H}_2\text{O}$; $\text{CuO} = 45.2$, $\text{SiO}_2 = 34.3$, $\text{H}_2\text{O} = 20.5$; Cryptocrystalline; Brittle; Fracture, conchoidal; $H. = 2-4$; $G. = 2-2.4$; Color, shades of blue and green passing into black by oxidation; Streak, white when pure; Luster, vitreous to earthy; Transparent to earthy.

B.B. — Deceperitates, infusible but yields a copper flame. Reduced with soda, borax, and a little coal dust, yields copper buttons. In the closed tube blackens and yields water. Decomposed with HCl with the separation of silica, but without gelatinizing.

General description. — Occurs in crusts, botryoidal, or filling veins and seams in the gangue rock of copper deposits. It is often impure from an admixture of silica, when it will appear much harder than 4. It becomes black from the formation of oxides.

Chrysocolla is a mineral deposited from the percolating waters which carry copper and silica, and is characteristic of the zone of oxidation. It is therefore associated with the superficial areas of most copper deposits.

Fine specimens have been obtained at Bisbee, Arizona; at Somerville, New Jersey, and in the Lake Superior copper region.

When in sufficient quantity it is an excellent copper ore. It is often polished and sold as an imitation turquoise.

TITANITE

Titanite. — Calcium titanosilicate, CaTiSiO_5 ; $\text{CaO} = 28.6$, $\text{TiO}_2 = 40.8$, $\text{SiO}_2 = 30.6$; Monoclinic; Type, Digonal Equatorial; $\dot{a} : \dot{b} : \dot{c} = .7546 : 1 : .8543$; $\beta = 60^\circ 17' = 001 \wedge 100$; $100 \wedge 110 = 33^\circ 14'$; $001 \wedge \bar{1}01 = 65^\circ 57'$; $001 \wedge 011 = 36^\circ 34'$; $001 \wedge 102 = 21^\circ$; $001 \wedge 111 = 38^\circ 16'$; Common forms, c (001), m (110), n (111), x (102), a (100), s (021); Twinning plane 100, both contact and penetrating, other twins rare; Cleavage, prismatic distinct; Brittle; Fracture, subconchoidal; $H. = 5-5.5$; $G. = 3.4-3.6$; Color, brown, yellow, gray, green, rose-red to black; Streak, white to pale brown; Transparent to opaque; $\alpha = 1.887$; $\beta = 1.894$; $\gamma = 2.009$; $\gamma - \alpha = .122$; Optically (+); Axial plane = 010; $B_{x_a} \wedge \dot{c} = 51^\circ$ in front; $2V = 27^\circ 30'$; $2E = 52^\circ 30'$.

B.B.—Fuses at 3 with intumescence, in most cases. The powdered mineral fused with soda and dissolved in strong HCl and heated with tin yields a violet-colored solution (titanium). Only slightly attacked by HCl, but decomposed by sulphuric acid.

General description.—Crystals are tabular parallel to the base in habit, or elongated parallel to the prism, when they are terminated by the unit pyramid. Usually combinations of the base, unit

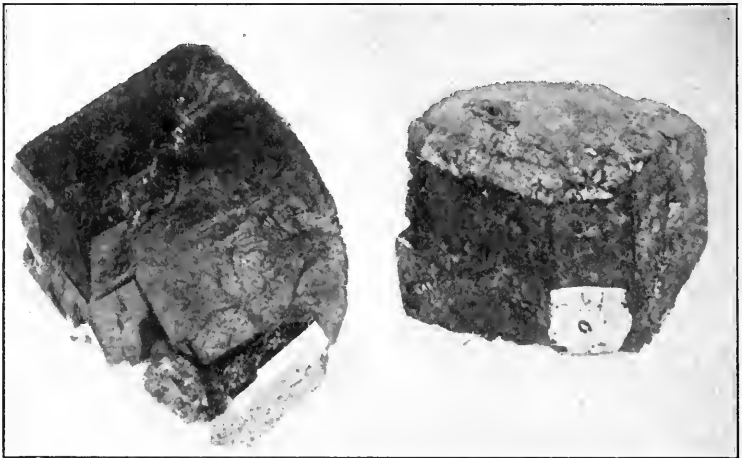

FIG. 512. —Titanite. Renfrew, Canada.

prism, and pyramid; other faces, as x , a , and s , are less common. A large number of rare forms have been described.

Chemically, some of the titanium may be replaced by ferric iron and aluminium, and a rose-red manganese variety occurs at St. Marcel, Piedmont, associated with piemontite, the manganese epidote.

In rock sections titanite appears in wedge-shaped outline or rounded grains, either colorless, pale yellow, or brown. The relief is very marked; cleavage in two directions distinct, but peculiar from the fact that they are never parallel to the crystal outline. The extinction due to dispersion is ill-defined. Interference colors vary greatly according to the direction of the section in the crystal, from gray of a high order to gray of the first order, when the two rays α and β , which are nearly equal, are vibrating in the section.

Titanite as a pyrogenetic accessory mineral is very widely distributed in all igneous rocks, except those rich in silica and magnesia. As a metamorphic mineral it occurs in the schists and crystalline limestones, where it is associated with such minerals as apatite, seapolite, zircon, hornblende. Especially fine crystals occur in a limestone at Renfrew County, Ontario. In the United States it occurs at numerous localities in the Atlantic coast states.

At St. Gothard, Switzerland, clear honey-yellow crystals occur, associated with adularia.

Alteration products of titanite are not common. At times it forms perovskite, CaTiO_3 , an isometric mineral crystallizing in cubes and octahedrons; by the elimination of both calcium and silica, rutile and octahedrite have been noted as being formed from titanite. Under favorable conditions the reverse of this may occur and titanite result from rutile or octahedrite, and especially from ilmenite, when the alteration product is known as leucoxene.

The synthesis of titanite has been effected by the simple fusion of its chemical constituents, at a temperature of 1400° . If the melt is low in silica, perovskite will form.

Benitoite, $\text{BaTi}(\text{SiO}_3)_3$, a titanosilicate of barium, is an interesting mineral, as it represents the ditrigonal equatorial type, which up to the time of its discovery had no representative. It occurs in San Benito County, California, imbedded in a vein of massive natrolite and associated with another rare titanium mineral, neptunite, $(\text{Na.K})_2(\text{Fe.Mn})(\text{Si.Ti})_5\text{O}_{12}$, heretofore only found at Narsarsuk, Greenland.

COLUMBITE

Columbite. — $(\text{Fe.Mn})(\text{CbO}_3)_2$; a columbate of iron and manganese; Orthorhombic; Type, Didigonal Equatorial; $\bar{a} : \bar{b} : \bar{c} = .8285 : 1 : .8897$; $100 \wedge 110 = 39^\circ 38'$; $001 \wedge 101 = 47^\circ 2'$; $001 \wedge 011 = 41^\circ 40'$; $001 \wedge 111 = 54^\circ 21'$; $001 \wedge 133 = 43^\circ 48'$; Common forms, **a** (100), **b** (010), **c** (001), **m** (110), **o** (111), **u** (133), **k** (103); Twinning plane, 021, contact and heart-shaped twins common; Cleavage, **a** distinct, **b** less so; Brittle; Fracture, uneven; $H. = 6$; $G. = 5.3-7.3$; Color, iron-black to brownish; Streak, dark red to black; Luster, submetallic, brilliant to resinous; Opaque, at times iridescent.

B.B. — Infusible or fuses with great difficulty. The S. Ph. bead saturated and reduced with tin on coal, then dissolved in a

little dilute HCl and boiled with tin, yields a turbid brown color; when boiled with zinc yields a blue color. Fused with soda in O. F. generally yields a green color (Mn). Insoluble in acids.

General description. — Either crystalline or massive; when crystalline, in short stout prisms or of tabular habit, parallel to the macropinacoid, at times acutely terminated by the pyramid (133).

It often contains considerable amounts of tantalum, tungsten, and tin. Tantalum and columbium form isomorphous compounds which are associated in nature; tantalite $(\text{Fe. Mn})(\text{TaO}_3)_2$ is a mineral isomorphous with columbite, and it is rarely that one is found without containing an admixture of the other crystallized with it. They also form a series of compounds with the rare earths, of which fergusonite $(\text{Y. Er. Ce})(\text{Cb. Ta})\text{O}_4$ is the most important. It occurs at Rockford, Massachusetts; in North Carolina; and in Llano County, Texas.

Columbite is associated with cassiterite, wolframite, ilmenite, magnetite, and other minerals found in pegmatites. It occurs in the pegmatites of Maine; brilliant crystals occur at Standish and Middletown, Connecticut; at various localities in North Carolina; in the pegmatites of the Black Hills in South Dakota, where crystals weighing nearly two thousand pounds have been found; here it is also associated with cassiterite and it has been concentrated by the same pneumatolytic agents. It is associated and contained in the cryolite deposit of West Greenland.

Tantalum has been used in the production of incandescent lamp filaments, which are much more efficient than the carbon lamps. Little or no columbite is mined in the United States.

CHAPTER XI

COLUMBATES, PHOSPHATES, VANADATES, INCLUDING NITRATES, BORATES, AND URANATES

MONAZITE

Monazite.—(Ce.La.Di)PO₄; an orthophosphate of the rare earths, cerium, lanthanum, and didymium; Monoclinic; Type, Digonal Equatorial; Ce₂O₃ = 37.26, (Ce.La.Di)₂O₃ = 31.60, P₂O₅ = 29.32, ThO₂ = 1.48; SiO₂ = .32 (North Carolina); $\bar{a} : \bar{b} : \bar{c} = 9693$; $1 : .9256$; $\beta = 76^\circ 20' = 001 \wedge 100$; $001 \wedge 110 = 43^\circ 17'$; $001 \wedge 101 = 37^\circ 7'$; $001 \wedge 011 = 41^\circ 58'$; $101 \wedge 100 = 39^\circ 12'$; $\bar{1}11 \wedge 100 = 48^\circ 30'$; Common forms, **a** (100), **b** (010), **m** (110), **w** (101), **x** ($\bar{1}01$), **r** (111), **v** ($\bar{1}11$), **e** (011); Twinning plane, 100; Cleavage, basal perfect, **a** distinct, **b** difficult; Brittle; Fracture, uneven; H. = 5-5.5; G. = 4.9-5.3; Color, clove-brown to yellow-brown, and red; Streak, white to yellowish; Luster, somewhat resinous; Translucent to opaque; $\alpha = 1.796$; $\beta = .1796$; $\gamma = 1.841$; $\gamma - \alpha = .045$; Optically (+); Axial plane perpendicular to 010; $Bx_a \wedge \bar{c} = 2^\circ 6' 30''$ in front; $2E = 24^\circ 36'$.

B.B.—Infusible; powdered and fused with soda, then dissolved in HNO₃, yields a yellow precipitate with ammonium molybdate, or the powdered mineral moistened with H₂SO₄ yields a green flame. In O. F. reacts for the rare earths. Page 572, decomposed with H₂SO₄, but difficultly soluble in HCl.

General description.—Crystals are tabular parallel to the orthopinacoid or elongated parallel to the orthoaxis, also massive or in rounded disseminated grains.

Monazite is an accessory mineral in certain granites, granitic gneisses, and pegmatites. Chemically it always contains some thorium, which may amount in some cases to 9 per cent. of ThO₂. In such cases it becomes a source of this rare earth, which is now used in considerable quantities in the manufacture of incandescent gas mantles. The bulk of the commercial supply of monazite is derived from Brazil, where it is separated from detrital sands. In the United States the supply is concentrated from sands at several

localities in North Carolina. It occurs at Amelia Court House, Virginia, in a granite associated with rutile and hiddenite. Often found in the gold gravels of the West, especially in Idaho. At Arendal, Norway, it is inclosed in the red apatite crystals.

APATITE

Apatite. — Fluo-phosphate of calcium, $\text{Ca}_4(\text{CaF})(\text{PO}_4)_3$; $\text{Ca} = 55.5$, $\text{P}_2\text{O}_5 = 42.3$; Hexagonal; Type, Hexagonal Equatorial; $c = .7346$; $0001 \wedge 10\bar{1}1 = 40^\circ 18'$; $0001 \wedge 1012 = 22^\circ 59'$; Common forms, $c(0001)$, $m(10\bar{1}0)$, $x(10\bar{1}1)$; Twinning, doubtful; Cleavage, basal imperfect; Brittle; Fracture, uneven; $H. = 5$; $G. = 3.17-3.23$; Color, shades of green, brown, and red, also white, gray, and violet; Streak, white or pale; Luster, vitreous; $\alpha = 1.638$; $\epsilon = 1.634$; $\omega - \epsilon = .004$; Optically (-).

B.B. — Fuses with difficulty at 5. The powder moistened with H_2SO_4 yields a green flame in O. F., or the nitric acid solution shows phosphoric acid with ammonium molybdate.

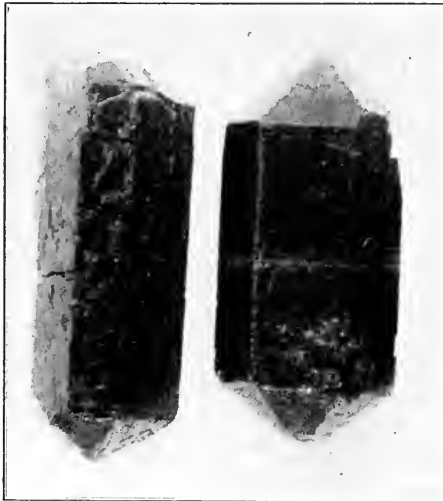

FIG. 513. — Apatite from Templeton, Canada.

The concentrated HNO_3 solution yields a white precipitate with $\text{H}_2\text{SO}_4(\text{Ca})$.

General description. — Crystals are stout prisms terminated with the pyramid of the first order, or with the pyramid in combination with the base. Combinations of the three orders of prisms, which as well as the etch figures fix the symmetry, occur on small, brilliant, colorless crystals found in a chloritic

schist, associated with epidote and adularia, in the Untersulzbachthal, Austria. All three orders of prisms are in combination on small tabular crystals, with small prism faces striated parallel to the vertical axis, occurring in veins associated with fluorite,

cassiterite, and sulphides at Ehrenfriedersdorf, Saxony. Crystals rich in forms have also been described from Branchville, Connecticut, and Alexander County, North Carolina.

Chemically there are two compounds, a chlor-apatite and a fluor-apatite, which are isomorphous and occur in the same crystals. It is rarely that one occurs without the other; in addition the chlorine or fluorine may be replaced by hydroxyl (OH); such specimens will yield a little water in the closed tube. Phosphatic rock found in the South and West is of the nature of apatite, but of organic origin; a bone phosphate, phosphatic nodules, coprolites, all of which are



FIG. 514.—Apatite. Snarum, Norway.

phosphates of calcium, but not crystalline, and therefore their composition varies greatly.

Extensive beds of these phosphates are found in South Carolina and the Gulf states; after treatment with sulphuric acid they form the superphosphates of the fertilizer industry.

Apatite occurs in rocks of all descriptions and under variable conditions. In igneous rocks it is always well crystallized, elongated parallel to the vertical axis; one of the very first minerals to separate from the magma; it appears as inclusions in all others, even penetrating the magnetite.

In rock sections it is colorless, with a hexagonal outline, or elongated when cut nearly parallel to \bar{c} ; such sections usually show a transverse parting, but the basal cleavage is seldom observed in sections. The relief is well marked; interference colors are grays of the first order. Apatite is a common mineral in the metamorphic rocks and crystalline limestones, where it is associated with titanite, scap-

olite, pyroxene, and vesuvianite. At Burgess, Ontario, hexagonal prisms a foot in length occur in the limestone. These large crystals always have a peculiar vitrified appearance, their edges are rounded as if they had been partly fused. Apatite occurs commonly along the Atlantic slope from Ontario to Georgia. It is associated with the tin veins of Bohemia and Cornwall, where its origin is due, as is also the cassiterite, to the chemical interaction of volatile fluorides and chlorides.

It is very peculiar that apatite, being quite soluble in acids and a salt of a weak acid, decomposes in nature with difficulty. Under the action of percolating waters containing carbon dioxide the calcium phosphate passes into solution, to be again separated as various



FIG. 515.—Section of a Mica-diorite, showing *a*, Apatite; *b*, Hornblende; *c*, Biotite; *e*, Quartz; and *f*, Feldspar partially Altered.

secondary iron phosphates, as vivianite, $\text{Fe}_3(\text{PO}_4)_2 \cdot 8 \text{H}_2\text{O}$, a common mineral of clays; also as dufrenite, $\text{Fe}_2(\text{OH})_3\text{PO}_4$; phosphosiderite, $2 \text{FePO}_4 \cdot 3\frac{1}{2} \text{H}_2\text{O}$; strengite, $\text{FePO}_4 \cdot 2 \text{H}_2\text{O}$; as secondary aluminium phosphates, wavellite, $\text{Al}_3(\text{OH})_3(\text{PO}_4)_2 \cdot 5 \text{H}_2\text{O}$; variscite, $\text{AlPO}_4 \cdot 2 \text{H}_2\text{O}$; turquoise, $\text{Al}_2(\text{OH})_3\text{PO}_4 \cdot \text{H}_2\text{O}$.

Artificial apatite has been formed by heating calcium and ammonium chlorides with calcium phosphate in a sealed tube at a temperature as low as 150°C . It has been reported as a constituent of some slags, but this has never been confirmed by analysis. Either chlor- or fluor-apatite may be produced in the dry fusion of sodium phosphate with either calcium chloride or calcium fluoride as the case requires.

PYROMORPHITE

Pyromorphite. — $\text{Pb}_5\text{Cl}(\text{PO}_4)_3$; Chloro-phosphate of lead; $\text{-PbO} = 82.3$, $\text{Cl} = 2.6$, $\text{P}_2\text{O}_5 = 15.7$; Hexagonal; Type, Hexagonal Equatorial; $\dot{c} = .7362$; $0001 \wedge 10\bar{1}1 = 40^\circ 22'$; $0001 \wedge 20\bar{2}1 = 59^\circ 32'$; Common forms, $c(0001)$, $m(10\bar{1}0)$, $x(10\bar{1}1)$, $y(20\bar{2}1)$; Cleavage, m and x in traces; Brittle; Fracture, conchoidal; $H. = 3.5\text{--}4$; $G. = 6.9\text{--}7$; Color, shades of green, yellow, or brown; Streak, white or pale; Luster, resinous; Subtranslucent to nearly opaque; $\omega = 1.51$; $\epsilon = 1.45$; $\omega - \epsilon = .006$; Optically (-).

B.B. — Fuses easily at 3.5. With soda and borax in R. F. on coal yields lead buttons and a lead coat. Dissolves in HNO_3 , yields a yellow precipitate with ammonium molybdate. When a S. Ph. bead is saturated with copper oxide and heated with the powdered mineral it shows chlorine. Some specimens may contain arsenic.

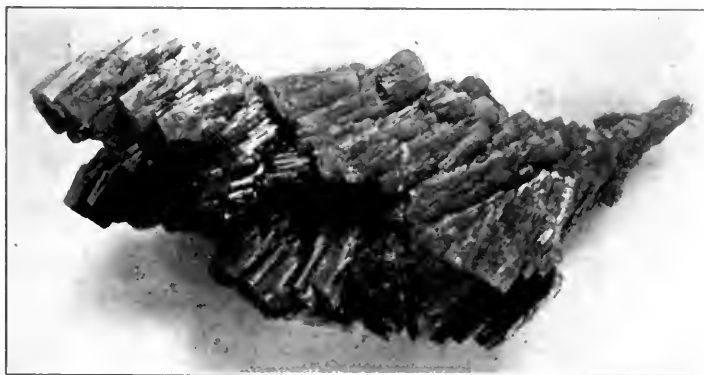

FIG. 516. — Pyromorphite from Baumbach, Prussia.

General description. — Crystals are columnar, striated lengthwise, usually hexagonal prisms roughly terminated or pitted at the termination. In rare cases they are terminated by the pyramid and base, as at Causthal in the Harz. Crystals from Ems, Nassau, are terminated by the base only. Also in parallel growths, irregular aggregates, or granular; sometimes in amorphous crusts and concretions.

Pyromorphite is a secondary mineral formed by the interaction of water containing phosphates in solution and lead ores. It is

characteristic of the zone of oxidation and is therefore found in the superficial workings of lead mines. While it is a valuable ore of lead, it occurs only in small quantities.

Good specimens have been obtained at the Wheatley mine, Chester County, Pennsylvania. It occurs in small quantities at various localities in New England and North Carolina.

Mimetite, $Pb_5Cl(AsO_4)_3$, a chlorarsenate of lead, is very similar in habit and occurrence to pyromorphite, with which it is isomorphous. In color it is yellow to greenish white and often in globular or barrel-shaped crystals.

Vanadinite, $Pb_5Cl(V_2O_4)_3$, a chlorvanadate of lead, another member of the apatite group, in which V_2O_5 takes the place of P_2O_5 or As_2O_5 . It is similar in habit and crystallization, but usually red to light yellow in color. It is associated with lead ores at various localities in Arizona and New Mexico.

Endlichite is a light yellow variety containing arsenic, occurring in Sierra County, New Mexico.

AMBLYGONITE

Amblygonite. — $Li(AlF)PO_4$; $Li_2O = 10.1$, $Al_2O_3 = 34.4$, $P_2O_5 = 47.9$, $F = 12.9$; Triclinic; Type, Centrosymmetric; $a : b : c = .7334 : 1 : .7633$; $\alpha = 108^\circ 51'$; $\beta = 97^\circ 48'$; $\gamma = 106^\circ 27'$; $100 \wedge 010 = 69^\circ 25'$; $100 \wedge 001 = 75^\circ 30'$; $010 \wedge 001 = 67^\circ 38'$; $100 \wedge 110 = 29^\circ 35'$; $001 \wedge 0\bar{2}1 = 74^\circ 40'$; Common forms, c (001), a (100), m (110), M ($\bar{1}10$), e ($0\bar{2}1$); Twinning plane, 101 and $\bar{1}01$, polysynthetic twins common, the two sets of striations making an angle of $89^\circ 8'$; Cleavage, basal perfect, at times e also; Brittle; Fracture, uneven; $H. = 6$; $G. = 3.01-3.09$; Color, white, gray, or pale blue, green, and brown; Streak, white; Luster, vitreous; Translucent to opaque; $\alpha = 1.579$; $\beta = 1.593$; $\gamma = 1.597$; $\gamma - \alpha = .018$; Optically (-).

B.B. — Fuses easily at 2 with intumescence and yields a lithium flame, especially when fused with the fluorite flux. When fused with soda and dissolved in nitric acid, shows phosphoric acid with ammonium molybdate. Usually contains some water from the replacement of F by OH.

General description. — Crystals are coarse and not well formed, usually in cleavable masses. It occurs in the coarse granites and

pegmatites of Maine, as at Hebron, Paris, and Auburn, where it is associated with spodumene, lepidolite, and tourmaline; also in North Carolina, and at Pala, San Diego County, California, with the same associated minerals.

Chemically some sodium may replace the lithium, when the flame will be mixed with yellow. There has been a variety described in which sodium occurs alone, without lithium, forming a sodium amblygonite.

OLIVENITE

Olivenite. — $\text{Cu}_2(\text{OH})\text{AsO}_4$; Basic copper arsenate; $\text{CuO} = 56.1$, $\text{As}_2\text{O}_5 = 40.7$, $\text{H}_2\text{O} = 3.2$; Orthorhombic; Type, Didigonal Equatorial; $\tilde{a} : \tilde{b} : \tilde{c} = .9396 : 1 : .6726$; $100 \wedge 110 = 43^\circ 13'$; $001 \wedge 101 = 35^\circ 36'$; $001 \wedge 011 = 33^\circ 55'$; Common forms, **a** (100), **b** (010), **m** (110), **e** (011), **v** (101); Cleavage, **m**, **b**, and **e** in traces; Brittle; Fracture, uneven; H. = 3; G. = 4.1; Color, shades of dark green and brown; Streak, green or brown; Luster, vitreous; Translucent to opaque.

B.B. — Fuses easily, yielding a bluish green flame. On coal yields an arsenical odor, and after roasting and reducing with soda, borax, and coal dust yields metallic copper; in the closed tube yields water. Soluble in nitric acid.

General description. — Crystals small, acicular, prismatic, or fibrous aggregates with a velvety surface. The brown varieties are known as "wood copper." Olivenite is a secondary mineral deposited in veins or cavities, associated with quartz in the oxidized zone of copper mines. Found in the United States in the Tintic district of Utah.

LIBETHENITE

Libethenite. — $\text{Cu}_2(\text{OH})\text{PO}_4$ is the phosphate of copper isomorphous with olivenite, and the two are therefore often crystallized together. It differs from olivenite in that the cold nitric acid solution yields a yellow precipitate with ammonium molybdate, (P_2O_5).

Adamite, $\text{Zn}_2(\text{OH})\text{AsO}_4$, is the zinc member of the series; it is associated with libethenite in the old zinc mines of Laurium in Greece.

DESCLOIZITE

Descloizite. — ZnPb(OH)VO_4 ; A basic vanadate of lead and zinc; $\text{PbO} = 55.4$, $\text{ZnO} = 19.7$, $\text{V}_2\text{O}_5 = 22.7$, $\text{H}_2\text{O} = 2.2$; Orthorhombic; Type, Didigonal Equatorial; $\tilde{a} : \tilde{b} : \tilde{c} = 0.6368 : 1 : 0.8045$; $100 \wedge 110 = 32^\circ 29' 40''$; $001 \wedge 101 = 51^\circ 38'$; $001 \wedge 011 = 38^\circ 49'$; Common forms, *a* (100), *m* (110), *b* (010), *o* (111), *f* (201); Cleavage, none; Brittle; Fracture, uneven; *H.* = 3.5; *G.* = 5.9–6.2; Color, orange-red, cherry-red, also shades of brown to black; Streak, orange to brownish; Luster, greasy; Transparent to opaque.

B.B. — Fuses easily; when reduced with soda, etc., on coal yields malleable lead buttons or a lead coat. Yields a green bead with the fluxes in R. F. and water in the closed tube. Easily soluble in cold dilute nitric acid which yields tests for vanadium, page 576.

General description. — Crystals are small prisms or pyramids, forming drusy surfaces on crusts; more often amorphous, powdery or earthy. The lead and zinc may be replaced by manganese or iron and at times some of the V_2O_5 is replaced by As_2O_5 ; several such compounds have received separate names.

Descloizite is found at Tombstone and various other localities in Arizona and New Mexico; also at Leadville, Colorado; and small quantities have been taken from the Wheatley mine at Phoenixville, Pennsylvania. Vanadium minerals are at the present time very valuable, as the vanadium is used in the manufacture of vanadium steel. A very small quantity of vanadium added to steel increases the toughness and the elastic limit without decreasing its ductility. Nickel accomplishes the same result, but vanadium is nearly twenty times as effective.

CARNOTITE

Carnotite. — $\text{KUO}_2\text{VO}_4 \cdot 1\frac{1}{2} \text{H}_2\text{O}$; a potassium uranyl vanadate; $\text{K}_2\text{O} = 10.37$, $\text{UO}_2 = 63.54$, $\text{V}_2\text{O}_5 = 20.12$, $\text{H}_2\text{O} = 5.95$.

A light canary-yellow mineral, disseminated as a yellow powder through sandstones in Montrose, San Miguel, and Mesa counties, Colorado, and the adjacent counties of Utah. It is easily soluble in acids and yields reactions for uranium and vanadium. It is a valuable mineral, not only for the large percentages of uranium and vanadium it contains, but also for the radium, which is associated with the uranium.

DUFRENITE

Dufrenite. — $\text{Fe}_2(\text{OH})_3\text{PO}_4$; a basic orthophosphate of iron; $\text{Fe}_2\text{O}_3 = 62.0$, $\text{P}_2\text{O}_5 = 27.5$; $\text{H}_2\text{O} = 10.5$; Orthorhombic; Type, ? $\bar{a} : \bar{b} : \bar{c} = .8734 : 1 : .4262$; $100 \wedge 110 = 41^\circ 8'$; $011 \wedge 0\bar{1}1 = 46^\circ 10'$; $001 \wedge 101 = 26^\circ 1'$; $001 \wedge 011 = 23^\circ 5'$; Common forms **a** (100), **b** (010), **m** (110), **e** (011); Cleavage, macropinacoidal distinct; Brittle; Fracture, uneven; H. = 3.5–4; G. = 3.2–3.4; Color, dark green to nearly black, brown and yellow by oxidation; Streak, green; Luster, dull to silky; Subtranslucent to opaque.

B.B. — Fuses in R. F. and becomes magnetic. Powdered and treated with H_2SO_4 yields a green flame in O. F., or dissolved in nitric acid shows phosphoric acid with ammonium molybdate. Yields water in the closed tube and only iron reactions with the fluxes.

General description. — Crystals are small and cubical in appearance, but very rare, generally occurring as radiated or fibrous masses with drusy surfaces.

Dufrenite is a secondary mineral, precipitated from solutions and associated with limonite deposits, as at Rockbridge County, Virginia. It is also found as a crust in the green sand formations of Allentown, New Jersey. By oxidation it becomes brown and by loss of P_2O_5 forms limonite.

LAZULITE

Lazulite. — $(\text{Fe, Mg})\text{Al}_2(\text{OH})_2(\text{PO}_4)_2$; when Fe : Mg : : 1 : 2, $\text{FeO} = 7.7$, $\text{MgO} = 8.5$, $\text{Al}_2\text{O}_3 = 32.6$, $\text{P}_2\text{O}_5 = 45.4$, $\text{H}_2\text{O} = 5.8$; Monoclinic; Type, Digonal Equatorial; $\bar{a} : \bar{b} : \bar{c} = .9749 : 1 : 1.6483$; $\beta = 89^\circ 13' = 001 \wedge 100$; $100 \wedge 110 = 44^\circ 16'$; $001 \wedge 101 = 58^\circ 49'$; $001 \wedge 011 = 58^\circ 45'$; Common forms, **P** (111), **e** ($\bar{1}\bar{1}\bar{1}$), **t** (101); Twinning plane, 100; Cleavage, prismatic distinct; Brittle; Fracture, uneven; H. = 5–6; G. = 3.06–3.12; Color, azure-blue; Streak, white; Subtranslucent to opaque; $\alpha = 1.603$; $\beta = 1.632$; $\gamma = 1.639$; $\gamma - \alpha = .036$; Optically (–); Axial plane parallel to 010; $\text{Bx}_{\bar{a}} \wedge \bar{c} = 9^\circ 20' - 9^\circ 45'$ behind; $2 \wedge \text{E} = 132^\circ$; Pleochroism strong.

B.B. — Swells, whitens, and crumbles. The powdered mineral moistened with H_2SO_4 yields a green flame (P_2O_5) or fused with

soda and dissolved in HNO_3 yields a yellow precipitate with ammonium molybdate (P_2O_5). Becomes blue when treated with cobalt solution (Al). Insoluble in acids.

General description. — Crystals are plus and minus unit pyramids, or combinations of these with the unit orthodome; other forms are rare. More often massive or granular, and associated with quartz and cyanite in slates. At Crowder Mountain, Gaston County, North Carolina, it is associated with corundum; at Graves Mountain, Georgia, it occurs in fine sky-blue crystals, an inch or more in length, associated with rutile and cyanite. Crystals six inches long occur in pockets of quartzite in Wermland, Sweden.

VIVIANITE

Vivianite. — $\text{Fe}_3(\text{PO}_4)_2 \cdot 8 \text{H}_2\text{O}$; Hydrous ferrous phosphate; $\text{FeO} = 43.0$, $\text{P}_2\text{O}_5 = 28.3$, $\text{H}_2\text{O} = 28.7$; Monoclinic; Type, Digonal Equatorial; $a : b : c = .7498 : 1 : .7016$; $\beta = 75^\circ 34' = 001 \wedge 100$; $100 \wedge 110 = 35^\circ 59'$; $001 \wedge \bar{1}01 = 49^\circ 46'$; $001 \wedge 011 = 34^\circ 11'$; Common forms, *a* (100), *b* (010), *m* (111), *n* (101); Cleavage, clinopinacoidal perfect, almost micaceous, very thin laminae slightly flexible and sectile; *H.* = 1.5–2; *G.* = 1.58–2.68; Color, blue to green; Streak, white to blue, darkens on exposure; Luster, vitreous to pearly; Transparent to opaque.



FIG. 517. — Vivianite. Leadville, Colorado. The smaller specimen is from Red Bank, N.J.

B.B. — Fuses easily at 1.5, and yields a green flame (P_2O_5). In R. F. blackens and becomes magnetic. Yields water in the closed tube. Dissolves in acids.

General description. — Crystals are prismatic and flattened parallel to the orthopinacoid, which is often rounded and striated lengthwise; also in interpenetrating stellate groups, or radiated, encrusted, friable, and earthy; at times replacing shells and roots and fossil bones, and is then known as bone turquoise.

Vivianite is a secondary mineral formed by the action of solutions containing ferrous iron on apatite or other calcium phosphates of organic origin. It occurs in the clays and gravel beds as blue nodules at several localities in Monmouth County, New Jersey. It is also associated with limonite, as at Stafford County, Virginia; replacing roots in clay at Eddyville, Kentucky. Groups of large crystals are obtained at Leadville, Colorado.

ERYTHRITE

Erythrite. — Red Cobalt; Cobalt bloom; Hydrous arsenate of cobalt, $Co_3(AsO_4)_2 \cdot 8 H_2O$; $CoO = 37.5$, $As_2O_5 = 38.4$, $H_2O = 24.1$; Monoclinic; Type, Digonal Equatorial; $\hat{a} : \hat{b} : \hat{c} = .7937 : 1 : .7356$; $\beta = 74^\circ 51'$; Common forms, **a** (100), **b** (010), **m** (110); Cleavage, **b** perfect, **a** and **w** (101) distinct, very thin laminae flexible and sectile; $H. = 1.5-2.5$; $G. = 2.95$; Color, crimson or shades of red and pink, sometimes grayish; Streak, pale; Luster, pearly on cleavage faces; Transparent to translucent.

B.B. — Fuses on coal to a dark globule and yields an arsenic odor. In the closed tube darkens and yields water. With borax yields a blue bead (Co). Dissolves in HCl to a rose-colored solution.

General description. — Crystals prismatic, in stellate or radiated aggregates; in drusy crusts or earthy. Associated with cobalt ores as an oxidation product. Beautiful radiated specimens are obtained at Schneeberg in the Harz and at Freiberg in Saxony. It is found as drusy crusts and as an earthy powder associated with the cobalt ores of Cobalt, Ontario.

The corresponding nickel mineral, Annabergite, $Ni_3(AsO_4)_2 \cdot 8 H_2O$, is apple green and is also found associated with the ores of cobalt and nickel as an oxidation product.

WAVELLITE

Wavellite. — $\text{Al}_3(\text{OH})_3(\text{PO}_4)_2 \cdot 5 \text{H}_2\text{O}$; hydrous basic aluminium orthophosphate; $\text{Al}_2\text{O}_3 = 38.0$, $\text{P}_2\text{O}_5 = 35.2$, $\text{H}_2\text{O} = 26.8$; Orthorhombic; Type, Didigonal Equatorial $\bar{a} : \bar{b} : \bar{c} = .5573 : 1 : .4084$; $100 \wedge 110 = 26^\circ 47'$; $001 \wedge 101 = 36^\circ 36'$; $001 \wedge 011 = 20^\circ 33'$; Common forms, **m** (110), **b** (010), **p** (101); Cleavage, **p** and **b** quite perfect; Brittle; Fracture, uneven; $H. = 3.25-4$; $G. = 2.3-2.33$; Color, shades of green, yellow, white to gray, when impure brown to black; Streak, white; Translucent to opaque; Luster, vitreous to pearly; $\gamma - \alpha = .025$; Optically (+); Axial plane = 100; $Bx_a = \bar{c}$; $2E = 127^\circ 2'$.

B.B. — Infusible, but whitens and crumbles somewhat; becomes blue with cobalt solution. The nitric acid solution yields a yellow precipitate with ammonium molybdate (P_2O_5). Soluble in hot strong acids.

General description. — Separate crystals are very rare; usually occurs in concretionary masses with drusy surfaces and radiated structure; also stalactitic or in crusts. Small amounts of iron or manganese may replace the aluminium, and while it is not recognized in the formula, fluorine is nearly always present.

Evansite, $\text{Al}_3(\text{OH})_6\text{PO}_4 \cdot 6 \text{H}_2\text{O}$, **peganite**, $\text{Al}_2(\text{OH})_3\text{PO}_4 \cdot 1\frac{1}{2} \text{H}_2\text{O}$, and **sphærite**, $\text{Al}_5(\text{OH})_9(\text{PO}_4)_2 \cdot 3\frac{1}{2} \text{H}_2\text{O}$, are other phosphates of aluminium with varying amounts of water, very closely related to wavellite.

They are all secondary minerals produced by the interaction of percolating waters, containing phosphates in solution, with argillaceous shales and slates, in the cracks and cavities of which they occur, never forming deposits of great extent.

Wavellite is associated with limonite at White Horse Station, Pennsylvania; at Magnet Cove, Arkansas, in fine green radiated aggregates.

TURQUOISE

Turquoise. — $\text{CuO} \cdot 3 \text{Al}_2\text{O}_3 \cdot 2 \text{P}_2\text{O}_5 \cdot 9 \text{H}_2\text{O}$; $\text{CuO} = 9$, $\text{Al}_2\text{O}_3 = 36.50$, $\text{P}_2\text{O}_5 = 34.13$, $\text{H}_2\text{O} = 20.12$; Triclinic; $a : b : c = .791 : 1 : .605$; $\alpha = 92^\circ 58'$; $\beta = 93^\circ 30'$; $\gamma = 107^\circ 41'$; $0\bar{1}0 \wedge 100 = 44^\circ 50'$; $100 \wedge 110 = 31^\circ 10'$; $0\bar{1}1 \wedge \bar{1}10 = 105^\circ 36'$; Forms **b** (010), **a** (100), **m** (110), **M** ($\bar{1}\bar{1}0$), **k** (011); Cleavage, marked; Brittle; Fracture,

conchoidal; $H. = 6$; $G. = 2.6-2.86$; Color, sky-blue to apple-green; Streak, white to pale green; Luster, waxy; Subtranslucent to opaque; $\alpha = 1.61$, $\gamma = 1.65$, $\gamma - \alpha = .04$.

B.B. — Infusible, becoming brown and glassy, yields a green flame. The S. Ph. bead reduced with tin shows copper. In the closed tube yields water.

General description. — Crystals of Turquoise were discovered for the first time at Lynch Station, Campbell County, Virginia, and described within the year. They were very small and scarce. Usually occurs in amorphous masses filling small veins in altered porphyries. In the United States turquoise is mined extensively at Mineral Park, Mohave County, Arizona; Washoe County, Nevada; Burro Mountains, New Mexico.

The blue color is due to copper, and in many specimens fades on exposure. The finest gem turquoise is found near Mishapur, Persia. Turquoise has been used as a gem from remote ages, as the bracelets discovered at El-Mehesna, the oldest known jewels, contained beads of turquoise alternated with beads of gold.

The American material is slightly soft and porous, which affects the polish.

Variscite. — $AlPO_4 \cdot 2 H_2O$; a crystalline hydrous phosphate of aluminium, very similar to turquoise in color, but lighter green to deep emerald green. It contains no copper and occurs in southwestern Utah, where it is found as nodules contained in a limestone, associated with jade, chalcedony, and limonite.

TORBERNITE

Torbernite. — Hydrous uranyl phosphate of copper, $Cu(UO_2)_2 \cdot (PO_4)_2 \cdot 8 H_2O$; $Cu = 8.4$, $UO_3 = 61.2$, $P_2O_5 = 15.1$, $H_2O = 15.3$; Tetragonal; $c = 2.9361$; $001 \wedge 101 = 71^\circ 11'$; Forms, c (001), m (110), a (100), e (101); Cleavage, basal micaceous; Brittle; $H. = 2-2.5$; $G. = 3.4-3.6$; Color, emerald or siskin-green; Streak, pale green; Luster, pearly; Transparent to opaque.

B.B. — Fuses at 2.5 to a black slag and yields water in the closed tube. Reduced with soda, etc., on coal, yields copper buttons. The nitric acid solution shows phosphoric acid with ammonium molybdate, also yields tests for uranium, page 576.

General description. — Crystals are thin plates or tabular; also in foliated and micaceous aggregates. Chemically some arsenic may replace the phosphoric acid. Zeunerite, $\text{Cu}(\text{UO}_2)_2(\text{AsO}_4)_2 \cdot 8 \text{H}_2\text{O}$, is the arsenic mineral isomorphous with torbernite and very similar to it, except in color, which is lemon or sulphur yellow.

Autunite, $\text{Ca}(\text{UO}_2)_2(\text{PO}_4)_2 \cdot 8 \text{H}_2\text{O}$, is a member of the same group, but orthorhombic and lemon or sulphur yellow in color.

All three minerals are secondary oxidation products associated with uranium deposits of Joachimsthal, Bohemia. Torbernite is associated in small amounts with the carnotite at Richardson, Utah.

NITRATES

SODA NITER

Soda Niter. — Chili Saltpeter, NaNO_3 ; Nitrate of soda; $\text{Na}_2\text{O} = 36.5$, $\text{N}_2\text{O}_5 = 63.5$; Hexagonal; Type, Dihexagonal Alternating; $\hat{c} = .8276$; $0001 \wedge 10\bar{1}1 = 43^\circ 42'$; $r \wedge r' = 73^\circ 30'$; Cleavage, rhombohedral perfect; Fracture, conchoidal; Brittle; H. = 1.5–2; G. = 2.24–2.29; Color, white, gray, red, brown, or yellow; Transparent; $\omega = 1.587$; $\epsilon = 1.336$; $\omega - \epsilon = .251$; Optically (–).

B.B. — Deflagrates on coal, colors the flame intensely yellow (Na). Has a cooling taste, easily soluble in water and yields reactions for nitrogen, page 590.

General description. — Crystals are rare, usually in beds, crusts, or granular. It is isomorphous with calcite, though differing from it entirely chemically. All nitrates are very soluble in water, and their occurrence in nature is therefore restricted to arid regions or to caves where little water has access. Nitrates are formed in the soils by the oxidation of organic matter through the action of certain bacteria. Nitrates are carried in the ground water and serve as a supply for growing vegetation. Nitrogen is one of the most expensive as well as the most important plant foods, and for this reason the nitrate deposits of Chili are of enormous commercial importance, as they are the only extensive deposits of nitrogen salts in the world. The origin of these beds has as yet not been satisfactorily explained. They may have been deposited by evaporating solutions, by volcanic action, or by decaying organic materials. They extend over an area of many square miles in

northern Chili, southern Peru, and Bolivia. The nitrate is associated with salt, gypsum, glauber salts, and generally borax. Small amounts occur in Humboldt County, Nevada, and in San Bernardino County, California.

NITER

Niter. — Saltpeter, Potassium Nitrate, KNO_3 ; $\text{K}_2\text{O} = 46.5$, $\text{N}_2\text{O}_5 = 53.5$; Orthorhombic; Type, Didigonal Equatorial; $\mathfrak{a} : \mathfrak{b} : \mathfrak{c} = .5843 : 1 : .7028$; $100 \wedge 110 = 39^\circ 35'$; $001 \wedge 101 = 49^\circ 30'$; $001 \wedge 011 = 35^\circ 2'$; Common forms, **b** (010), **m** (110), **t** (021), **o** (111), **q** (011); Cleavage, 011 perfect, 010 and 110 imperfect; Brittle; Fracture, uneven; H. = 2; G. = 2.09–2.14; Color and streak, white; Luster, vitreous; Subtranslucent; $\alpha = 1.334$; $\beta = 1.505$; $\gamma = 1.506$; $\gamma - \alpha = .172$; Optically (–); Axial plane = 100; $\text{Bx}_a = \bar{\mathfrak{b}}$; $2\text{E} = 8^\circ 40'$.

B.B. — Deflagrates on coal, yielding a violet flame (K), has a cooling saline taste. Easily soluble in water, the solution yields reactions for nitrogen, page 590.

General description. — Crystals are acicular, forming crusts or silky tufts, as efflorescent crusts in dry regions. It is an oxidation product found in soils, the result of the action of certain nitrifying bacteria; the nitric acid thus formed combines with the bases, with potassium to form niter, or with calcium to form nitrocalcite, $\text{Ca}(\text{NO}_3)_2 \cdot n (\text{H}_2\text{O})$.

Niter is dimorphous, and in each form is isomorphous with the two forms of calcium carbonate, calcite and aragonite. The orthorhombic form here, however, is stable at ordinary temperatures. The hexagonal phase of soda-niter is stable at ordinary temperatures and forms the natural occurring salt.

Niter is of great commercial importance both as a fertilizer and in the manufacture of gunpowder, the natural supply being so limited that the salt is formed from Chili saltpeter by the interaction of potassium chloride.

Niter is associated to some extent with the sodium salts in the Chili nitrate beds. It also occurs as an impregnation in the earth on the floors of some of the caves in Kentucky and Tennessee. It is often obtained by lixiviating such soils.

BORACITE

Boracite. — $Mg_7Cl_2B_{16}O_{30}$; A chloride and borate of magnesium; $MgO = 31.4$, $Cl = 7.9$, $B_2O_3 = 62.5$; Pseudo-isometric; Type, Ditesseral Polar; Common forms, $a(100)$, $d(110)$, $\pm o(111)$; Twinning plane, 111; Cleavage, 111 traces; Fracture, conchoidal; Brittle; $H. = 7$; $G. = 2.9-3$; Color, white, gray, pale yellow, or green; Streak, white; Transparent to translucent; Double refraction below 265° ; $\alpha = 1.662$; $\beta = 1.667$; $\gamma = 1.673$; $\gamma - \alpha = 0.11$.

B.B. — Fuses easily at 2, intumesces and yields a green flame. With cobalt solution a flesh color (Mg). Yields a chlorine reaction with CuO , soluble in HCl . The massive variety yields water.

General description. — Crystals cubic or tetrahedral in habit; generally isolated simple crystals, or massive and granular. The faces of the plus tetrahedron are bright and highly polished, while those of the minus form are dull. The polar nature of boracite is brought out on heating, when the plus and minus tetrahedrons show opposite polarity.

Boracite is dimorphous, the orthorhombic form is stable at ordinary temperatures and passes over to the isometric form at 265° . The beautifully formed isometric crystals at ordinary temperatures are complex aggregates of orthorhombic twins and twinning lamellæ, as is shown by their double refraction, all of which disappear when heated to 265° , at which temperature the mineral becomes isotropic, and even the polarity disappears. Chemically magnesium may be replaced by ferrous iron, as in the green boracites. Artificial boracite has been formed in which Zn , Cd , or Ni enter as the base, while the chlorine has been replaced with iodine.

Boracite occurs in the Stassfurt salt deposits, imbedded in the gypsum, anhydrite, and carnallite.

Stassfurtite is a massive variety, which is softer than the crystalline and yields water in the closed tube.

BORAX

Borax. — $Na_2B_4O_7 \cdot 10 H_2O$; Hydrrous sodium pyroborate; $Na_2O = 16.23$, $B_2O_3 = 36.65$, $H_2O = 47.12$; Monoclinic; Type, Digonal Equatorial; $a : b : c = 1.0995 : 1 : .5632$; $\beta = 73^\circ 25' =$

001 \wedge 100; 1001 \wedge 10 = $46^{\circ}30'$; 001 \wedge $\bar{1}01$ = $29^{\circ}54'$; 001 \wedge 011 = $28^{\circ}21'$; Common forms, **a** (100), **c** (001), **b** (010), **n** (110), **o** (111), **z** (221); Twinning plane **a**; Cleavage, orthopinacoidal perfect, **m** less so; Brittle; Fracture, conchoidal; H. = 2-2.5; G. = 1.69-1.72; Color, white, gray, or pale blue or green; Streak, white; Luster, vitreous to earthy; Transparent to opaque; α = 1.446; β = 1.469; γ = 1.472; $\gamma - \alpha$ = .026; Optically (-); Axial plane \perp 010; **Bx** \wedge \bar{c} = $71^{\circ}35'$ in the obtuse angle; $2E$ = $59^{\circ}18'$.

B.B. — Fuses easily with intumescence to a clear bead. With Turner's flux yields a green flame. Soluble in water, the solution reacts for boric acid with turmeric paper. Has a sweetish, alkaline taste.

General description. — Crystals prismatic in habit, often large, some from the California lake regions weigh as much as a pound each. More often granular, earthy, and impure. This crude, impure borax is sold in the trade as tincal, and was first brought from the borax lakes of Tibet. Owing to its solubility in water, borax is found associated with deposits formed by the concentration of the waters of certain lakes. Such lakes are found in the West, as in San Bernardino County, California, where the borax is associated with gypsum, anhydrite, thenardite, glauberite, hanksite, halite, colemanite, and trona. It is also found in the saline lakes and marshes of Nevada and Oregon, and at other localities in California; associated with the soda niter in Chili and the salt deposits of Stassfurt, Germany; in the hot springs of the Yellowstone Park and in sea water. The origin of the borax in all these deposits is uncertain; at Stassfurt it has been by concentration of the solutions, while in numerous other localities its origin may be traced to volcanic and fumarole action. Sassolite, H_3BO_3 , or the orthoboric acid, is found in solution in the waters issuing from the fumaroles of Tuscany; from these solutions it is recovered by evaporation.

Owing to the varied properties of borax, it finds many and widely different uses. When fused it dissolves the oxides of the metals, yielding characteristically colored glasses which form the color base in stained glass. It is used in soldering to dissolve the oxides from the surface of the metals; as a flux in the melting and purification of the precious metals; in the manufacture of enamel and granite ware and in encaustic tiles. From its cleansing powers it is used

in making soap, and from its preservative properties it is used in the canning of meats and vegetables and to prevent fermentation in milk.

ULEXITE

Ulexite. — $\text{NaCaB}_5\text{O}_7 \cdot 8 \text{H}_2\text{O}$; a hydrous sodium calcium borate; $\text{Na}_2\text{O} = 7.7$, $\text{CaO} = 13.8$, $\text{B}_2\text{O}_3 = 43.0$, $\text{H}_2\text{O} = 35.5$; Monoclinic, elements or angles not determined; $H. = 1$; $G. = 1.65$; Color and streak, white; Luster, silky; Translucent.

B.B. — Fuses easily with intumescence to a clear glass, and colors the flame yellow (Na). With Turner's flux yields a green flame (B). In the closed tube yields water, and after ignition reacts alkaline with turmeric paper. Insoluble in cold water, but slightly soluble in hot water, yielding an alkaline solution.

General description. — Crystals very fine and fibrous, in round masses, with a loose, porous texture, commonly known as snowball or cotton mineral by the prospectors. It forms around the cracks or small holes where the solutions escape at the surface by evaporation. It is the common borate at Teel's, Rhodes', and Columbus marshes, Nevada; also in Inyo and San Bernardino counties, California, which are practically a continuation of the Nevada field. Ulexite is also associated with soda niter in the deposits of the dry deserts of Tarapaca and Atacama, northern Chili. It is probably formed by the interaction of solutions containing borax and calcium bicarbonate.

In commerce it is used in the manufacture of borax and boric acid.

COLEMANITE

Colemanite. — $\text{Ca}_2\text{B}_6\text{O}_{11} \cdot 5 \text{H}_2\text{O}$; a hydrous calcium borate; $\text{CaO} = 27.2$, $\text{B}_2\text{O}_3 = 50.9$, $\text{H}_2\text{O} = 21.9$; Monoclinic; Type, Digonal Equatorial; $a : b : c = .7748 : 1 : .5410$; $\beta = 69^\circ 51' = 001 \wedge 100$; $100 \wedge 110 = 36^\circ 2'$; $001 \wedge 101 = 42^\circ$; $001 \wedge 011 = 26^\circ 55'$; $001 \wedge 111 = 33^\circ 45'$; $001 \wedge 110 = 73^\circ 49'$; Common forms, a (100), b (010), c (001), m (110), β (111), h (201); Cleavage, b perfect, c distinct; Brittle; Fracture, uneven; $H. = 4-4.5$; $G. = 2.42$; Color, white, yellowish, or gray; Streak, white; Luster, vitreous; Transparent to translucent; $\alpha = 1.586$; $\beta = 1.592$; $\gamma = 1.614$; $\gamma - \alpha = .028$; Optically (+); Axial plane $\perp 010$; $Bx_a \wedge c = 83^\circ$ in front; $2E = 95^\circ 15'$; $2V = 54^\circ 52'$.

B.B. — Exfoliates, decrepitates, and colors the flame green. Soluble in HCl, yielding a boric acid reaction with turmeric paper.

General description. — Crystals prismatic combinations of **a**, **b**, **c**, and **m**, other forms less prominently developed. Beautiful groups of highly lustrous crystals associated with quartz occur in geodes of the massive mineral, to which the terms priceite and pandermite have been applied.

Colemanite was first discovered in the Death Valley, California; it also occurs in Nevada, Oregon, and Chili.

It is the most abundant borate in the California locality, and is the source from which borax and borates are derived. The product or pulp is treated with sulphuric or sulphurous acid, precipitating the calcium, leaving the boric acid in solution, which is recovered in the crude form by evaporation.

URANINITE

Uraninite. — Pitchblende, U_3O_8 or $(UO_2)(UO_3)_2$; Uranoso-uranic oxide; Composition, variable; Isometric; Type, Ditesseral Central; Common forms **o**(111), **d**(110), sometimes **a**(100); Cleavage, none; Brittle; Fracture, conchoidal; H. = 3–6; G. = 9–9.7; Color, pitch-black or greenish; Streak, olive-green, brown to gray; Luster, greasy, pitchy, or dull submetallic; Opaque.

B.B. — Infusible; with borax or S. Ph. a green bead in R. F. (U). Yields tests for uranium, page 576.

General description. — Crystals are combinations of the octahedron, rhombic dodecahedron, and at times the cube; they are rare; it usually occurs massive or amorphous, pitchlike in appearance. Its chemical composition is variable, some lead is almost always present, and calcium, copper, iron, arsenic, bismuth, thorium, cerium, and the yttrium earths may also enter into its composition. Cleveite, a variety from Arendal, Norway, contains 10 per cent. of the yttrium earths.

It was in uraninite that Klaproth, in 1789, discovered uranium, and Péligré separated the metal in 1842, Klaproth's product being the oxide UO_2 . It was also from this mineral that Madam Curie separated radium, and it has since been proven that radium and helium contained in the mineral are the results of the breaking

down of uranium; pitchblende is therefore radioactive, and is at present the source of radium.

Crystals of uraninite occur in the granites and pegmatites of Moss and Arendal, Norway; Cornwall, England; and in the feldspar quarries of Middletown, Connecticut. The massive mineral is associated with ore veins at Joachimsthal and Schneeberg. In the United States it is found in Gilpin County, Colorado; in the Black Hills, South Dakota, and in Llano County, Texas.

It is the present source of radium and uranium.

Uranium compounds are used in the laboratory in the determination of phosphorus and zinc; in photography; in pottery glazes; for coloring glass; in the manufacture of special steels for use in gun barrels, and as a pigment.

Gummite is an alteration product of uraninite, of a light reddish yellow or yellowish brown color, containing considerable water. It is associated with the pitchblende of Flat Rock, Mitchell County, North Carolina. Some of the rounded masses of orange-red color still contain a nucleus of unaltered uraninite.

CHAPTER XII

SULPHATES, CHROMATES, TUNGSTATES, AND MOLYBDATES

THENARDITE

Thenardite. — Anhydrous sodium sulphate, Na_2SO_4 ; $\text{Na}_2\text{O} = 56.3$, $\text{SO}_3 = 43.7$; Orthorhombic; Type, Didigonal Equatorial; $\bar{a} : \bar{b} : \bar{c} = .5976 : 1 : 1.2524$; $100 \wedge 110 = 30^\circ 52'$; $001 \wedge 101 = 64^\circ 30'$; $001 \wedge 011 = 51^\circ 24'$; Common forms, *c* (001), *a* (110), *m* (110), *o* (111), *t* (106), *r* (101), *e* (011); Twinning plane, 101, also 011, crossed twins common; Cleavage, basal distinct; Fracture, uneven; Brittle; H. = 2-3; G. = 2.68-2.69; Color, white, gray or brownish; Streak, white; Transparent to translucent; Optically (+); Axial plane, 001; $\text{Bx}_a = \bar{b}$; $2\text{V} = 83^\circ 32'$.

B.B. — Fuses easily and colors the flame yellow (Na). Easily soluble in water, the solution yielding a heavy white precipitate with barium chloride (BaSO_4). After ignition reacts alkaline with turmeric paper.

General description. — Crystalline habit is pyramidal or short prismatic, usually combinations of the unit pyramid, prism, base, and dome. Owing to its great solubility in water its occurrence is restricted to desert lake regions, as those of Siberia, Chili, Arizona, Nevada, and California.

Sodium sulphate is the last of the sulphates to crystallize from solution upon evaporation. The anhydrous sulphate is separated above a temperature of 32°C .; below this temperature the decahydrate mirabilite, $\text{Na}_2\text{SO}_4 \cdot 10 \text{H}_2\text{O}$, is in equilibrium and separates from the saturated solution. In a dry atmosphere this effloresces, losing its water and passing into the anhydrous salt thenardite.

Thenardite is associated with halite, trona, gypsum, hanksite, borax, and other minerals characteristic of the desert lake deposits.

GLAUBERITE

Glauberite. — $\text{Na}_2\text{Ca}(\text{SO}_4)_2$; Sodium calcium sulphate; $\text{Na}_2\text{O} = 22.3$, $\text{CaO} = 20.1$, $\text{SO}_3 = 57.6$; Monoclinic; Type, Digonal Equatorial; $\tilde{a} : \tilde{b} : \tilde{c} = 1.2199 : 1 : 1.0275$; $\beta = 67^\circ 49' = 001 \wedge 100$; $100 \wedge 110 = 48^\circ 29'$; $001 \wedge 101 = 30^\circ 37'$; $001 \wedge 011 = 43^\circ 34'$; $110 \wedge 111 = 32^\circ 29'$; Common forms, **a** (100), **c** (001), **m** (110), **s** (111); Cleavage, basal perfect; Fracture, conchoidal; Brittle; $H. = 2.5-3$; $G. = 2.7-2.85$; Color, pale yellow, gray, or red; Streak, white; Luster, vitreous; Transparent to translucent; Optically (-); Axial plane $\perp 010$; $\text{Bx}_a \tilde{c} = 30^\circ 46'$ in front; $2E = 11^\circ$.

B.B. — Whitens, decrepitates, and fuses at 1.5, coloring the flame intensely yellow (Na). Dissolves in HCl; the solution yields a white precipitate with barium chloride (BaSO_4). Whitens in water, depositing gypsum, which also dissolves in an excess. Has a bitter, salty taste.

General description. — Crystals tabular in habit, combinations of **c**, **s**, **m**, and **a**; at times the pyramid predominates. The faces **c** and **s** are often striated parallel to their intersection.

Glauberite is associated with the deposits of other soluble sodium salts, as at Stassfurt, Germany; Tarapaca, Chili; and the various borax and salt lakes of Nevada and California.

BARITE

Barite. — Heavy spar; Barium sulphate, BaSO_4 ; $\text{BaO} = 65.7$, $\text{SO}_3 = 34.3$; Orthorhombic; Type, Didigonal Equatorial; $\tilde{a} : \tilde{b} : \tilde{c} = .8152 : 1 : 1.3136$; $100 \wedge 110 = 39^\circ 11'$; $001 \wedge 101 = 58^\circ 11'$; $001 \wedge 011 = 52^\circ 43'$; $111 \wedge 001 = 64^\circ 19'$; $102 \wedge \bar{1}02 = 77^\circ 43'$; Common forms, **a** (100), **b** (010), **c** (001), **m** (110), **o** (011), **d** (102); Twinning planes, 110 and 601 both developed as lamellæ; Cleavage, basal and prismatic perfect, **b** imperfect; Fracture, uneven; Brittle; $H. = 2.5-3.5$; $G. = 4.3-4.6$; Color, white, or pale shades of yellow, green, blue, brown, or red; Streak, white; Luster, vitreous; Transparent to translucent; $\alpha = 1.637$; $\beta = 1.638$; $\gamma = 1.649$; $\gamma - \alpha = .012$; Optically (+); Axial plane, 010; $\text{Bx}_a = \tilde{c}$; $2E = 63^\circ 12'$.

B.B. — Often decrepitates, whitens, and fuses at 3, coloring the flame yellowish green (Ba). After ignition reacts alkaline with

turmeric paper. Fused with soda and a little coal dust in R. F. yields a sulphur reaction on silver. Insoluble in acids.

General description. — Crystals are tabular parallel to the base, when they are combinations of *m*, *c*, *o*, and *d*. The perfect cleavages parallel to *m* and *b*, which are usually to be observed, serve to orient the crystals. It is also elongated in habit parallel to the brachyaxis; again parallel to the macroaxis; but rarely are the crystals elongated parallel to the vertical axis, as at Betler, Hungary. Parallel growths are common when tabular in habit; they are joined by the base, yielding at times a cockscomb-like surface or radiated, with deep reëntrant angles separating the individuals. It also occurs in beds, massive, granular, radiated, in banded nodules, as well as stalactitic.



Fig. 518. — Barite and Dolomite from Cumberland, England.

Barite is easily distinguished from other white minerals by its weight, from which it takes its common miner's name of heavy spar. The various shades, other than white, are due to impurities. It often contains calcium or strontium sulphates, with which it is isomorphous.

Barite is a secondary mineral associated with sedimentary rocks and ore veins. In ore veins it is more often associated with lead and zinc ores and with veins containing sulphides. In such veins it is deposited through the interaction of percolating waters, carrying barium in solution, either as the chloride or the bicarbonate, with soluble sulphates, as gypsum, or with sulphates furnished by the oxidation of sulphides, as pyrite. Beautiful crystals of barite are

found on the walls of cavities in the lead mines of Cornwall, England. Crystals elongated parallel to \bar{a} are associated with the iron mines of West Cumberland, England, in cavities of dolomite.

Wonderfully developed tabular crystals, associated with and penetrated by acicular crystals of stibnite, are characteristic of Felsöbanya, Hungary. Barite has also been observed as the cementing material in some sandstones, where also it must have been deposited by double decomposition. It occurs around some springs as a sinter and is also deposited in pipes in mines, being precipitated from the mine waters. It is associated with limestones as lenticular deposits, and it is from such occurrences that all the commercial barite is mined. In the United States barite is mined in the lead regions of Missouri, also in Tennessee, Virginia, and North Carolina; while in small amounts it is widely distributed. Good crystals are found at Sterling, Colorado; at Cheshire, Connecticut; at the Perkiomen lead mine, Pennsylvania.

Uses. — Ground barite when pure white is used as a paint, as a filler for paper, and, owing to its insolubility, in rubber goods. It is also the principal source of the barium salts. The banded varieties are cut and polished as vases, mantles, and for other ornamental purposes.

CELESTITE

Celestite. — Strontium sulphate, SrSO_4 ; $\text{SrO} = 56.4$, $\text{SO}_3 = 43.6$; Orthorhombic; Type, Didigonal Equatorial; $\bar{a} : \bar{b} : \bar{c} = .7789 : 1 : 1.2800$; $100 \wedge 110 = 37^\circ 55'$; $001 \wedge 101 = 58^\circ 40'$; $001 \wedge 011 = 52^\circ$; $102 \wedge \bar{1}02 = 78^\circ 49'$; $001 \wedge 111 = 64^\circ 21'$; Common forms, a (100), b (010), c (001), m (110), o (102), p (011), z (111); Cleavage, basal and prismatic perfect, b less so; Brittle; Fracture, uneven; $H. = 3-3.5$; $G. = 3.95-4$; Color, faint bluish white, rarely red; Streak, white; Luster, vitreous; Transparent to translucent; $\alpha = 1.622$; $\beta = 1.623$; $\gamma = 1.629$; $\gamma - \alpha = .007$; Optically (+); Axial plane = 010; $Bx_a = \bar{a}$; $2E = 88^\circ 38'$.

B.B. — Often decrepitates, whitens, and fuses at 3, yielding a deep red flame; after ignition reacts alkaline with turmeric paper. Fused with soda and a little coal dust in R. F. yields a sulphur reaction on silver. Insoluble in acids.

General description. — In crystalline habit and general appearance like barite, with which it is isomorphous. It is not as common in its occurrence as barite and is less often associated with ore de-

posits; but is more often associated with gypsum and halite deposits, and fills cavities in limestones and dolomites, where it has been deposited by percolating waters. Sulphur and celestite are common associates in the region of volcanoes or solfataras. The most noted occurrence of this character is that of Girgenti, Sicily, which furnishes beautiful crystals of both celestite and sulphur. At many localities, as at Tyrone, Pennsylvania, a fibrous blue celestite, filling veins, occurs. A red variety occurs in Brown County, Kansas. Very large crystals are found on Strontian Island, Lake Erie. Clear crystals associated with colemanite occur in Death Valley,



FIG. 519.—Celestite. Put-in-Bay, Ohio.

California; also large crystals at Lampasas, Texas. Celestite is the source of strontium salts; for their uses see strontianite.

ANHYDRITE

Anhydrite.—Calcium sulphate, CaSO_4 ; $\text{CaO} = 41.2$, $\text{SO}_3 = 58.8$; Orthorhombic; Type, Didigonal Equatorial; $\bar{a} : \bar{b} : \bar{c} = .8932 : 1 : 1.0008$; $100 \wedge 110 = 41^\circ 46'$; $001 \wedge 101 = 48^\circ 15'$; $001 \wedge 011 = 45^\circ 1'$; Common forms, **a** (100), **b** (010), **c** (001), **m** (110), **z** (111); Twinning plane, 012; Cleavage, basal and brachypinacoidal perfect, **a** less so; Brittle; Fracture, uneven; H. = 3–3.5; G. = 2.9–3; Color white, gray, or pale shades of yellow, blue, or red; Streak, white; Luster, vitreous; Transparent to translucent; $\alpha = 1.569$; $\beta = 1.575$; $\gamma = 1.613$; $\gamma - \alpha = .044$; Optically (+); Axial plane, 010; $\text{Bx}_a = \bar{a}$; $2\text{E} = 70^\circ 18'$.

B.B.—Whitens and fuses at 3, yielding a yellowish red flame (Ca); after ignition reacts alkaline with turmeric paper. Fused with a little coal dust in R. F. on coal yields a sulphur reaction with silver. Soluble in HCl. Yields no water in the closed tube.

General description.—Crystals are not common; when well formed they are stout, tabular combinations of the three pinacoids, in combination with a pyramid or two, as at Aussee in Styria. A simple combination of the two unit domes elongated parallel to the

macroaxis occurs on crystals from Stassfurt. It is usually granular, massive, lamellar, or fibrous. While it is classed with the barite group of sulphates, it differs from other members of the group widely in its cleavage and axial ratio. Anhydrite is also the most soluble of the series, and is therefore carried in solution longer and farther than the others, and is often deposited by the evaporation of these natural waters.

It occurs in beds connected with salt deposits; in the evaporation and deposition of the soluble salts from saturated solutions, anhydrite is normally on the bottom of such deposits, with the more soluble magnesium, sodium, and potassium compounds above it.

In the normal concentration of a calcium sulphate solution at ordinary temperatures, gypsum is deposited, but when the solution contains sodium chloride or magnesium salts, anhydrite is deposited at temperatures as low as 25° C. Gypsum in a concentrated solution of sodium chloride at 30° passes over to anhydrite, and, while gypsum is the first mineral to separate on concentration, very often when concentration has advanced the sulphate first crystallized as gypsum forms anhydrite. Under heat and pressure gypsum may lose its water and be transformed to anhydrite, or the reverse of this is also possible and anhydrite by hydration in many cases forms gypsum. The two minerals are often mixed, areas of anhydrite occur containing considerable gypsum, which is probably secondary to the anhydrous sulphate.

Anhydrite occurs at the borax lakes and salt deposits of California and Nevada, at the salt deposits of Michigan; at Lockport, New York; in Nova Scotia, at the mouth of the Avon and St. Croix rivers. Commercially anhydrite is of little value; when attractively colored and veined it is polished as an ornamental stone. Artificial crystals may be formed by fusing calcium sulphate and sodium chloride.

ANGLESITE

Anglesite. — Sulphate of lead, PbSO_4 ; $\text{PbO} = 73.6$; $\text{SO}_3 = 26.4$; Orthorhombic; Type, Didigonal Equatorial; $\text{a}:\text{b}:\text{c} = .7852:1:1.2894$; $100 \wedge 110 = 38^\circ 8'$; $001 \wedge 101 = 58^\circ 40'$; $001 \wedge 011 = 52^\circ 12'$; $102 \wedge 102 = 78^\circ 47'$; $001 \wedge 111 = 64^\circ 24'$; Common forms, *a*(100), *b*(010), *c*(001), *m*(110), *d*(102), *z*(111); Cleavage, basal and prismatic distinct; Fracture, conchoidal; Brittle; *H.* = 2.75–3; *G.* = 6.1–6.4; Color, white, gray or pale yellow. or blue; Streak, white; Luster, adamantine to resinous; Trans-

parent to opaque; $\alpha = 1.877$; $\beta = 1.882$; $\gamma = 1.894$; $\gamma - \alpha = .017$; Optically (+); Axial plane, 010; $Bx_a = \tilde{a}$; $2V = 66^\circ 47'$.

B.B. — Decrepitates and fuses at 1.5. In R. F. on coal reduces to lead and yields a lead coat; fused with soda and a little coal dust yields a sulphur reaction with silver. Insoluble in acids.

General description. — Crystals often tabular in habit, combinations of *c*, *m*, and *d*, or elongated similar to barite, with which it is isomorphous. Transparent crystals have a particularly high luster, as the specimens from Monte Poni, Sardinia, where they occur implanted on galena. Anglesite is named for the island of Anglesea, where it was first observed associated with an earthy limonite.

Anglesite is an oxidation product associated with lead ores, particularly with galena, and when in sufficient quantities it is a valuable lead ore.

CROCOITE

Crocoite. — Lead chromate, $PbCrO_4$; $PbO = 68.9$, $CrO_3 = 31.1$; Monoclinic; Type, Digonal Equatorial; $\tilde{a} : \tilde{b} : \tilde{c} = .9603 : 1 : .9158$; $\beta = 77^\circ 33' = 001 \wedge 100$; $100 \wedge 110 = 43^\circ 10'$; $001 \wedge 101 = 37^\circ 41'$; $001 \wedge 011 = 41^\circ 48'$; $111 \wedge \bar{1}\bar{1}1 = 60^\circ 50'$; Common forms, *b* (010), *c* (001), *m* (110), *t* (111), *v* (111); Cleavage, *m* distinct, *a* and *c* less so; Brittle; Fracture, uneven; *H.* = 2.5–3; *G.* = 5.9–6.1; Color, bright hyacinth-red; Streak, orange-red; Luster, adamantine to vitreous; Transparent to translucent; $\beta = 2.42$; Optically (+); Axial plane, 010; $Bx_a \wedge \tilde{c} = 5^\circ 30'$; $2V = 54^\circ 3'$.

B.B. — Fuses at 1.5, and reduced on coal with soda yields lead buttons and a lead coat. In *S. Ph.* yields a green bead in both flames (Cr). In the closed tube blackens and decrepitates, but recovers its original color on cooling.

General description. — Crystals are elongated parallel to the vertical axis with striations on the prism faces lengthwise. At times apparently rhombohedral or granular.

Crocoite was described as a new mineral from the Urals in Russia by Lehmann in 1762, where it occurs associated with quartz crystals. It was in crocoite that Klaproth and Vauquelin independently in 1797 discovered the metal chromium.

Beautiful long, slender crystals with nearly a square cross section have been found at Dundas, Tasmania. It also occurs in

Brazil, the Philippine Islands, and in Maricopa County, Arizona, where it is associated with vanadinite and wulfenite.



FIG. 520. — Crocoite from Dundas, Tasmania.

Lead chromate is used as an oxidizer and as a pigment, but this is the artificial salt, as crocoite is too scarce and not sufficiently pure.

KAINITE

Kainite. — $\text{MgSO}_4 \cdot \text{KCl} \cdot 3 \text{H}_2\text{O}$; $\text{K}_2\text{O} = 18.9$, $\text{MgO} = 16.1$, $\text{Cl} = 14.3$, $\text{SO}_3 = 32.1$, $\text{H}_2\text{O} = 21.8$; Monoclinic; Type, Diagonal Equatorial; $\mathbf{a} : \mathbf{b} : \mathbf{c} = 1.2187 : 1 : .5863$; $\beta = 85^\circ 6' = 001 \wedge 100$; $100 \wedge 110 = 50^\circ 32'$; $001 \wedge 101 = 24^\circ 43'$; $001 \wedge 011 = 30^\circ 18'$; $111 \wedge \bar{1}11 = 54^\circ 1'$; Common forms, \mathbf{a} (100), \mathbf{b} (010), \mathbf{c} (001), \mathbf{m} (110), \mathbf{o} (111), ω ($\bar{1}11$); Cleavage, \mathbf{a} distinct, and \mathbf{b} less so; $H. = 2.5-3$; $G. = 2.06-2.2$; Color, white to dark flesh-red or yellow; Streak, white; Luster, vitreous; Transparent to translucent; Optically (-); Axial plane, 010; $\mathbf{Bx}_a \wedge \mathbf{c} = 10^\circ 45'$ in front; $2V = 84^\circ 33'$.

B.B. — Yields a potassium flame. Soluble in water, the solution yields a white precipitate with barium nitrate (BaSO_4), filtered and acidified with nitric acid yields a white precipitate with silver nitrate (Cl), or reacts for chlorine with copper oxide. Will not effervesce with acids. Has a bitter, saline taste.

General description.—Crystals are combinations of the plus and minus unit pyramids and prism, with the pinacoids at times.

The base is usually rough and uneven. It is more often granular or massive.

Kainite being very soluble in water has been deposited from concentrated sea water; when this concentration has reached the stage where the sulphates have been deposited and the mother liquor is saturated in respect to the chlorides and sulphates, double salts are separated, of which kainite is an example. This mineral, however, may have been formed by the interaction of carnallite ($\text{KCl} \cdot \text{MgCl}_2 \cdot 6 \text{H}_2\text{O}$) and kieserite ($\text{MgSO}_4 \cdot \text{H}_2\text{O}$) as a secondary mineral.

Kainite is found in quantities at the unique salt deposits of Stassfurt and in small deposits of the same character in Galicia. These two deposits are of great commercial value, as they furnish the potash supply to the world, and which is essential as one of the necessary plant foods, so apt to be early exhausted from the soil.

HANKSITE

Hanksite. — $9\frac{1}{2} \text{Na}_2\text{SO}_4 \cdot 2\text{Na}_2\text{CO}_3 \cdot \text{K}_2\text{A}$ A double salt found under the same conditions as kainite, and interesting as one of the few minerals illustrating the dihexagonal equatorial type. Its crystals are tabular combinations of the base, unit pyramid, and prism. It is found associated with the borax lake deposits of California.

MIRABILITE

Mirabilite. — Hydrous sodium sulphate, $\text{Na}_2\text{SO}_4 \cdot 10 \text{H}_2\text{O}$; $\text{Na}_2\text{O} = 19.3$, $\text{SO}_3 = 24.8$, $\text{H}_2\text{O} = 55.9$; Monoclinic; Type, Digonal Equatorial; $\hat{a} : \hat{b} : \hat{c} = 1.1158 : 1 : 1.2372$; $\beta = 72^\circ 15' = 001 \wedge 100$; $100 \wedge 110 = 46^\circ 44'$; $001 \wedge 101 = 57^\circ 55'$; $001 \wedge 011 = 49^\circ 41'$; Common form, $a(100)$, $b(010)$, $c(001)$, $m(110)$; Cleavage, a perfect, c and b in traces; H. = 1.5-2; G. = 1.48; Color and streak, white; Luster, vitreous; Transparent to opaque; $\beta = 1.44$; Optically (-); Axial plane $\perp 010$; $\text{Bx}_a = \hat{b}$; $2\text{E} = 122^\circ 48'$.

B.B. — Boils and yields a yellow flame (Na). In the closed tube yields much water. After ignition leaves an alkaline residue. Very soluble in water, the solution yields a white precipitate with barium chloride (BaSO_4). Has a cooling, bitter taste.

General description. — Occurs as crusts or in beds in the deposits formed by the evaporation of salt lakes. Sodium sulphate is contained in varying amounts in all natural waters; upon con-

centration mirabilite separates from the saturated solution when the temperature is below 32° ; when the temperature is higher, the anhydrous salt, thenardite, is separated. Its solubility varies greatly with the temperature, thus at Great Salt Lake, Utah, on cold days in winter large amounts of sodium sulphate are thrown up on the shore by the waves, only to be redissolved when the temperature rises. In a dry atmosphere it loses its water of crystallization, falling down as a fine white powder. It also occurs as an efflorescence on rocks or near springs, where much water is quietly evaporating.

GYPSUM

Gypsum. — $\text{CaSO}_4 \cdot 2 \text{H}_2\text{O}$; Hydrous calcium sulphate; $\text{CaO} = 32.5$, $\text{SO}_3 = 46.6$, $\text{H}_2\text{O} = 20.9$; Monoclinic; Type, Digonal Equatorial; $\hat{a} : \hat{b} : \hat{c} = .6899 : 1 : .4124$; $\beta = 80^{\circ} 42' = 001 \wedge 100$; $100 \wedge 110 = 34^{\circ} 15'$; $001 \wedge 101 = 28^{\circ} 17'$; $001 \wedge 011 = 22^{\circ} 9'$; $111 \wedge \bar{1}\bar{1}1 = 36^{\circ} 12'$; Common forms, **b** (010), **c** (001), **m** (110), **l** (111), **n** (111); Twinning plane, 100, contact and crossed penetrating, also 101 less common; Cleavage, clinopinacoidal perfect, **a** less so, and 111 fibrous; laminae flexible parallel to the fibrous cleavage; $H. = 1.5-2$; $G. = 2.3-2.33$, when pure; Color, white, pale yellow, red, brown to black when organic matter is present; Streak, white; Luster, silky, pearly, vitreous to dull; Transparent to opaque; $\alpha = 1.5204$; $\beta = 1.5229$; $\gamma = 1.5296$; $\gamma - \alpha = .009$; Optically (+); Axial plane = 010; $\text{Bx}_a \wedge \hat{c} = 52^{\circ} 30'$ in front; $2V = 58^{\circ} 8'$.

B.B. — Whitens and fuses to an opaque white mass at 3; colors the flame yellowish red; after ignition reacts alkaline with turmeric paper. In the closed tube yields water. Fused with soda and a little coal dust in the R. F. reacts for sulphur with silver. Soluble in HCl.

General description. — Crystals usually simple combinations of the plus and minus unit pyramids with the unit prism and the clino- and basal pinacoids. Crystals six feet in length have been found in Wayne County, Utah. The faces **m** and **b** often striated parallel to their intersection with the base. Parallel growths and rounded stellate aggregates are common, as at St. Mary's River, Maryland, and Postelberg, Bohemia. Twinning in which the composition plane is parallel to the orthopinacoid, forming the well-known swallow-tail twins, and, when the crystals are rounded,

the arrowhead twins, is common at Montmartre near Paris. Simple crystals are more often found in clays, as at Poland, Ohio.

All crystalline gypsum which shows the perfect cleavage is known as selenite. The fibrous variety with a satiny or pearly luster and a fibrous fracture is satin spar, while the granular massive variety is alabaster. Rock gypsum is an impure granular form, often earthy. Gypsum is deposited from solution and is associated with sedimentary rocks, limestones, and clays, from which the soluble calcium sulphate has been leached out. It is also associated with salt deposits, being deposited from the concentrated brines before

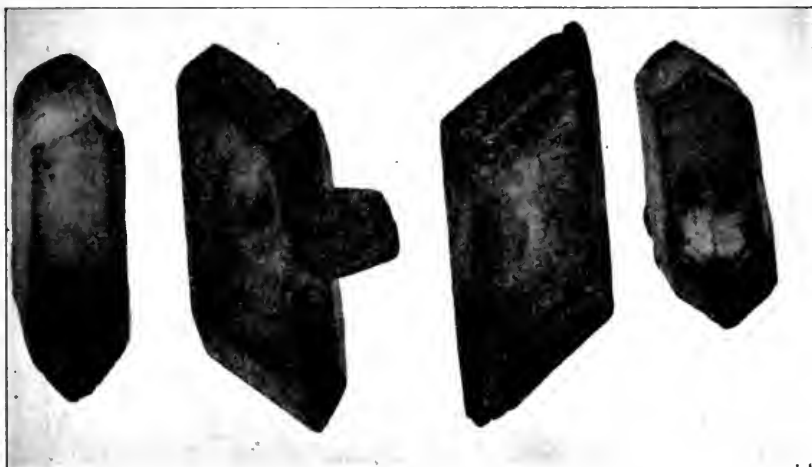

FIG. 521.—Gypsum. Poland, Ohio.

the more soluble sodium or magnesium sulphates and chlorides, and therefore in the usual position underlying the salt, or is near it in position; at times, when there have been several distinct periods of concentration, it may be interbedded with salt and shales. Large beds of rock gypsum are found in the Salina formations of New York, but here the gypsum beds are above the salt and are probably independent of it, the concentration of the solution having been interrupted before the salt was deposited.

Large beds of gypsum are found in Nova Scotia, Newfoundland, Michigan, and in the borax lakes regions of California and Nevada. Gypsum is also formed near volcanoes and fumaroles; small crystals of gypsum cover the walls of the lava caves of Kilauea.

Commercially rock gypsum is ground and used as a fertilizer. The purer varieties, when heated at a temperature below 130° C.,

until one molecule of the water of crystallization is driven off, form a cement known as "plaster of Paris," named from the Montmartre deposits near Paris where this cement was first made. This calcined product when moistened absorbs water, forming a network of fibrous crystals, and solidifies as a whole. When all the water of crystallization is driven off, it forms anhydrite; the product loses its power to absorb water or absorbs it very slowly, and its setting or crystallizing power is lost.

Satin spar and alabaster are polished as ornamental stones and for inexpensive jewelry.

EPSOMITE

Epsomite. — Epsom salts, $\text{MgSO}_4 \cdot 7 \text{H}_2\text{O}$; $\text{MgO} = 16.3$, $\text{SO}_3 = 32.5$, $\text{H}_2\text{O} = 51.2$; Orthorhombic; Type, Dignonal Holoaxial; $\bar{a} : \bar{b} : \bar{c} = .9902 : 1 : .5709$; $100 \wedge 110 = 44^\circ 43'$; $001 \wedge 101 = 29^\circ 58'$; $001 \wedge 011 = 29^\circ 43'$; $111 \wedge \bar{1}\bar{1}\bar{1} = 52^\circ 38'$; Common forms, a (100), b (010), c (001), z (111), n (101); Cleavage, b perfect, 011 less so; Brittle; Fracture, conchoidal; $H. = 2-2.5$; $G. = 1.68-1.75$; Color and streak, white; Transparent to translucent; $\alpha = 1.432$; $\beta = 1.455$; $\gamma = 1.461$; $\gamma - \alpha = .029$; Optically (-); Axial plane = 001; $\text{Bx}_a = \bar{b}$; $2E = 78^\circ 20'$.

B.B. — Boils and yields an infusible white alkaline residue which becomes flesh-pink when treated with cobalt solution (Mg). Soluble in water; the solution yields a white precipitate with barium chloride (BaSO_4). It has a very bitter taste.

General description. — Crystals are prismatic in habit, combinations of the sphenoids and unit prism; they are interesting as examples of the holoaxial type; also in fine silky acicular crystals. The mineral is named from the locality of Epsom Springs, England, where it was first known.

Magnesium sulphate is easily soluble in water; all springs and percolating ground waters contain both magnesium and calcium sulphates in considerable quantity. They cause the permanent hardness of natural waters. Where large amounts of water are evaporating, as on the face of cliffs or on the surface of the soil in very dry seasons, epsomite is left as white crusts. The white crusts formed on fresh brick walls are in part epsomite. Such residual crusts occur on the floors of the caves of Tennessee and Kentucky and on many of the alkaline plains of California, Utah, and Nevada.

Kieserite, $\text{MgSO}_4 \cdot \text{H}_2\text{O}$, is a magnesium sulphate containing only one molecule of water. It is monoclinic and much less soluble than epsomite, but dissolves slowly in water and recrystallizes as epsomite at ordinary temperatures. Kieserite separates from solutions above 68°C . Kieserite is associated with carnallite and gypsum at the Stassfurt salt deposits. Here it has been separated from solutions containing sodium and potassium salts, and under these conditions a number of double salts have been formed, as blödite, $\text{Na}_2\text{Mg}(\text{SO}_4)_2 \cdot 4 \text{H}_2\text{O}$; löweite, $\text{Na}_2\text{Mg}(\text{SO}_4)_2 \cdot 2\frac{1}{2} \text{H}_2\text{O}$; picromerite, $\text{K}_2\text{Mg}(\text{SO}_4)_2 \cdot 6 \text{H}_2\text{O}$.

Isomorphous with epsomite is the zinc sulphate, goslarite, $\text{ZnSO}_4 \cdot 7 \text{H}_2\text{O}$, derived from the oxidation of sphalerite and occurring on the walls of old mine workings; also morenosite, $\text{NiSO}_4 \cdot 7 \text{H}_2\text{O}$; the nickel sulphate is a member of the same group.

Commercially magnesium sulphate is separated at the Stassfurt works. It is used in medicine as a purgative, and as a coating for cotton cloth in dyeing.

MELANTERITE

Melanterite. — Copperas; Ferrous sulphate, $\text{FeSO}_4 \cdot 7 \text{H}_2\text{O}$; $\text{FeO} = 25.9$, $\text{SO}_3 = 28.8$, $\text{H}_2\text{O} = 45.3$; Monoclinic; Type, Digonal Equatorial; $\hat{a} : \hat{b} : \hat{c} = 1.1828 : 1 : 1.5427$; $\beta = 75^\circ 44' = 001 \wedge 100$; $100 \wedge 110 = 48^\circ 54'$; $001 \wedge 101 = 43^\circ 44'$; $001 \wedge 011 = 56^\circ 13'$; $111 \wedge 111 = 78^\circ 33'$; $001 \wedge 110 = 80^\circ 41'$; Common forms, b (010), c (001), m (110), r (111), o (011), v (101); Cleavage, basal perfect, m less so; Brittle; Fracture, conchoidal; $H. = 2$; $G. = 1.89-1.90$; Color, shades of green to yellow; Streak, white; subtransparent to translucent; $\alpha = 1.471$; $\beta = 1.478$; $\gamma = 1.485$; $\gamma - \alpha = .014$; Optically (+); Axial plane = 010; $\text{Bx}_a \wedge \hat{c} = 62^\circ 28'$ behind; $2V = 88^\circ 48'$.

B.B. — Fuses and blackens, leaving a magnetic residue on coal, which reacts only for iron with the fluxes. In the closed tube yields water. Soluble in water; the solution acidified with HCl yields a white precipitate with barium chloride; yields a sulphur reaction with soda on silver. It has an astringent, metallic taste.

General description. — Crystals are short, prismatic in habit, but the salt in nature is usually fine fibrous, massive, or concretionary. The yellow color of some specimens is caused by oxidation

on exposure. Chemically it may contain some magnesium, as epsomite is very closely related.

Pisanite is a variety containing copper.

Melanterite is the result of the oxidation of such sulphides as pyrite, marcasite, pyrrhotite, or other sulphides containing iron; the soluble ferrous sulphate is carried off in solution, to be deposited by evaporation, as copperas if the conditions are favorable. All mine waters in sulphide regions contain ferrous sulphate in solution, which according to the conditions may form several iron sulphates, as coquimbite, $\text{Fe}_2(\text{SO}_4)_3 \cdot 9 \text{H}_2\text{O}$, the ferric sulphate, or the ferrous ferric sulphate roemerite, $\text{FeFe}_2(\text{SO}_4)_4 \cdot 12 \text{H}_2\text{O}$.

Iron sulphates are not common in nature, as owing to their solubility they may occur only under very restricted conditions.

The commercial copperas is a by-product produced in the precipitation of copper sulphate with scrap iron. It is used as a disinfectant, in dyeing, in the manufacture of ink and pigments.

CHALCANTHITE

Chalcanthite. — Blue vitriol; Copper sulphate, $\text{CuSO}_4 \cdot 5 \text{H}_2\text{O}$; $\text{CuO} = 31.8$; $\text{SO}_3 = 32.1$; $\text{H}_2\text{O} = 36.1$; Triclinic; Type, Centrosymmetric; $\bar{a} : \bar{b} : \bar{c} = 0.5721 : 1 : .5554$; $\alpha = 82^\circ 5'$; $\beta = 107^\circ 8'$; $\gamma = 102^\circ 41'$; $100 \wedge 010 = 79^\circ 6'$; $100 \wedge 110 = 26^\circ 7'$; $010 \wedge 011 = 64^\circ 58'$; $011 \wedge \bar{0}11 = 56^\circ 59'$; $100 \wedge 011 = 69^\circ 50'$; Common forms, a (100), b (010), m (110), M ($\bar{1}\bar{1}0$), p (111), Cleavage, M , m , and p imperfect; Brittle; Fracture, conchoidal; $H. = 2.5$; $G. = 2.12-2.3$; Color, shades of blue; Streak, white; Luster, vitreous; Translucent; $\alpha = 1.514$; $\beta = 1.537$; $\gamma = 1.543$; $\gamma - \alpha = .029$; Optically (-); $2E = 93^\circ$. The normal to the optic plane makes an angle of $53^\circ 30'$ with the normal to 110, with $\bar{1}\bar{1}0$ an angle of $12^\circ 30'$, and with the normal to $\bar{1}\bar{1}\bar{1}$, 67° .

B.B. — Fuses easily on coal and blackens; reduced with soda, yields copper, and a sulphur reaction on silver. In the closed tube yields water. Soluble in water, and has a metallic taste.

General description. — Crystals stout, tabular parallel to 111 with the zone c , b striated parallel to their intersection. More often massive, granular, stalactitic or in crusts.

Chalcanthite occurs in many copper mines, where it is deposited from the mine waters on evaporation. It is derived from the oxidation of sulphides in the upper levels of the ore deposits and is

carried down to the lower zones in solution, where it is usually re-deposited by the action of pyrite as sulphide; but where conditions favor the evaporation of the solution, it may form the sulphate. The mine waters of Butte, Montana, and at Bisbee, Arizona, contain considerable copper in solution as the sulphate, which is recovered by allowing it to run slowly over scrap iron.

Good specimens are obtained from the Copper Queen mine, Bisbee, Arizona; and from Isabella mine, Polk County, Tennessee.

Brochantite, $\text{Cu}_4(\text{OH})_6\text{SO}_4$, is a basic copper sulphate, orthorhombic in symmetry, insoluble in water, and without taste; other tests like chalcantite; occurs in the Tintic district, Utah; Chaffee County, Colorado; and at several localities in Arizona.

Owing to its rare occurrence chalcantite is unimportant commercially; the artificial blue vitriol is used in electric batteries, as a fungicide in Bordeaux mixture, and as a mordant in dyeing.

ALUNITE

Alunite. — $\text{KAl}_2(\text{OH})_6(\text{SO}_4)_2 \cdot 3 \text{H}_2\text{O}$; a basic potassium aluminium sulphate; $\text{K}_2\text{O} = 11.4$, $\text{Al}_2\text{O}_3 = 37.0$, $\text{SO}_3 = 38.6$, $\text{H}_2\text{O} = 13.0$; Hexagonal; Type, Dihexagonal Alternating; $c = 1.252$; $0001 \wedge 10\bar{1}1 = 55^\circ 19'$; $10\bar{1}1 \wedge 1101 = 90^\circ 50'$; Cleavage, basal distinct; Brittle; Fracture, uneven; $H. = 3.5-4$; $G. = 2.58-2.75$; Color, white, gray, or pale red; Streak, white; Luster, vitreous to pearly; Transparent to opaque; $\omega = 1.572$; $\epsilon = 1.592$; $\epsilon - \omega = .020$; Optically (+).

B.B. — Infusible, but may decrepitate when ignited; treated with cobalt solution becomes blue (Al). In the closed tube yields water, and fused in R. F. with soda and a little coal dust yields a sulphur reaction on silver. Insoluble in HCl, soluble in H_2SO_4 .

General description. — Crystals are small and rhombohedral in habit, usually combinations of several rhombohedrons of the same series. More often massive, granular, or of a fibrous-like structure.

Alunite is very local in its occurrence, and it has been produced by the action of sulphurous fumes on the feldspars of such rocks as rhyolites, andesites, or trachytes, or by the decomposition of these rocks by percolating waters containing sulphuric acid, as in the Goldfield district of Nevada; here the formation of alunite has a direct connection with the workable deposits of gold. It also

occurs at Cripple Creek, Colorado; in Mariposa County, California; near Morenci, Arizona.

Alunogen, $\text{Al}_2(\text{SO}_4)_3 \cdot 18 \text{H}_2\text{O}$, hydrous sulphate of aluminium, is soluble in water and occurs as an efflorescence on the walls of coal mines. Formed by the action of sulphuric acid on shales. A large deposit, fibrous in character, occurs at Smoky Mountain, North Carolina.

Aluminite $(\text{AlO})_2\text{SO}_4 \cdot 9 \text{H}_2\text{O}$, a basic sulphate insoluble in water, is found in concretionary forms imbedded in clay.

Kalinite, $\text{KAl}(\text{SO}_4)_2 \cdot 12 \text{H}_2\text{O}$, is a natural potash alum, found as an efflorescence on slates and on the walls of caves of Tennessee.

All these minerals were found in sufficient quantities are used in the manufacture of soluble aluminium salts and alum.

WOLFRAMITE

Wolframite. — Tungstate of iron and manganese, $(\text{Fe} \cdot \text{Mn})\text{WO}_4$; when $\text{Fe}:\text{Mn}::4:1$, $\text{FeO} = 18.9$, $\text{MnO} = 4.7$, $\text{WO}_3 = 76.4$; Monoclinic; Type, Digonal Equatorial; $\mathbf{a}:\mathbf{b}:\mathbf{c} \doteq .8300:1:.8678$; $\beta = 89^\circ 21' = 001 \wedge 100$; $100 \wedge 110 = 39^\circ 41'$; $001 \wedge 101 = 45^\circ 56'$; $001 \wedge 011 = 40^\circ 57'$; Common forms, \mathbf{a} (100), \mathbf{m} (110), \mathbf{t} (102), \mathbf{y} ($\bar{1}02$), \mathbf{o} ($\bar{1}11$); Twinning axis \mathbf{c} , composition plane, 100; Cleavage, \mathbf{b} perfect; Brittle; Fracture, uneven; $H. = 5-5.5$; $G. = 7.2-7.5$; Color, dark brown to nearly black; Streak, brownish or reddish to nearly black; Luster, metallic adamantine to dull; Opaque, rarely translucent.

B.B. — Fuses at three or four to a globule which in R. F. is usually magnetic. When dissolved in the S. Ph. bead and reduced with tin on coal yields a blue solution when dissolved in HCl. Fused with soda in O. F. yields green sodium manganate.

General Description. — Crystals tabular with 100 prominent, or stout prismatic, striated on 100 parallel to the vertical axis. Also in granular masses.

Wolframite is an isomorphous mixture of hübnerite, MnWO_4 , the tungstate of manganese, and ferberite, FeWO_4 , the tungstate of iron. Hübnerite occurs as brown, translucent, bladed crystals, while ferberite is black and opaque.

The three minerals occur under the same conditions, usually in quartz veins in granites, associated with sulphides; here they have probably been precipitated from hot solutions. They also occur

in pegmatites, associated with cassiterite, as in Cornwall, England; in the Black Hills, South Dakota; also in the Seward Peninsula, Alaska. In all such cases their origin, like that of the cassiterite, is due to pneumatolitic agencies. A third but less common occurrence is the replacement in limestone, as at Turnbull, Connecticut.

Wolframite and hübnerite occur in numerous localities in the Western states, associated with gold-bearing quartz veins, but always in small amounts. Wolframite is mined on a commercial scale in Boulder County, Colorado. Hübnerite was first described or obtained from the Enterprise mine, Nevada, where it is associated in a vein with apatite, fluorite, and scheelite.

Commercially wolframite is the principal source of the metal tungsten and its salts. The metal is added to steel in the form of ferrotungsten, producing a tungsten steel which will retain its temper when working at or near a red heat; from this steel, lathe tools, drills, hack saws, etc., are manufactured. Incandescent lamp filaments made of tungsten yield a very white light and reduce the current used to $1\frac{1}{4}$ watts per candle power, while the carbon filament requires three watts. Sodium tungstate is used in fireproofing curtains and draperies; as a mordant in dyeing. Calcium tungstate is the phosphorescent salt with which the screen used in viewing the Röntgen rays is coated.

Artificial wolframite may be produced by fusing sodium tungstate and the chlorides of sodium, manganese, and iron. When the iron is left out, hübnerite is the result.



FIG. 522. — Wolframite Crystal from Zinnwald, Bohemia.

SCHEELITE

Scheelite. — Calcium tungstate, CaWO_4 ; $\text{CaO} = 19.4$, $\text{WO}_3 = 80.6$; Tetragonal; Type, Tetragonal Equatorial; $\epsilon = 1.5356$;

$001 \wedge 101 = 56^\circ 55'$; $111 \wedge \bar{1}\bar{1}1 = 79^\circ 55'$; $101 \wedge 011 = 72^\circ 40'$; Common forms, *p* (111), *e* (101), *c* (001), *h* (313), *s* (311); Twinning plane, 100, both contact and interpenetrating; Cleavage, 111 distinct, *e* interrupted; Brittle; Fracture, uneven; *H.* = 4.5–5; *G.* = 5.9–6.1; Color, white, pale yellowish white, pale yellow to brown; Streak, white; Luster, adamantine to vitreous; Transparent to opaque; $\omega = 1.934$; $\epsilon = 1.918$; $\omega - \epsilon = .016$; Optically (-).

B.B. — Fuses at 5. When dissolved in S. Ph., the bead is yellow in O. F., blue in R. F. when cold; the same bead reduced beside tin on coal shows tungsten, page 587. Soluble in HNO_3 , or HCl, leaving a yellow powder (WO_3), which is soluble in ammonia.

General description. — Crystals octahedral in habit, combinations in which the pyramid of the second order usually predomi-

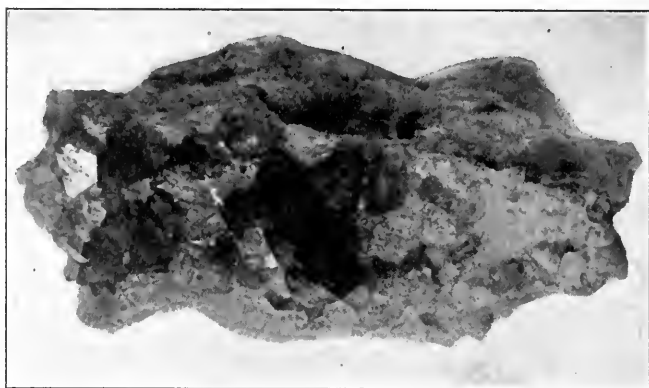

FIG. 523. — Scheelite and Fluorite from Schwarzenberg, Saxony.

nates. Crystals from Turnbull, Connecticut, are combinations of the first and second order pyramids in which the former predominates.

Scheelite is interesting as an example of the tetragonal equatorial type, and pyramids of all three orders occur on crystals from Schlackenwald and Zinnwald, Bohemia. It also occurs massive.

Chemically copper may replace some of the calcium; the pure copper tungstate is the mineral, cuprotungstite, CuWO_4 , from La Paz, Lower California. Molybdenum may replace the tungsten, as in the variety, or mineral, powellite of western Idaho.

Tungstic acid (WO_3) was discovered in scheelite, in 1781, by the

chemist Scheele, for whom it was named. Tungsten is Swedish for heavy stone, in reference to the high specific gravity of all the minerals containing it.

In occurrence, association, and artificial production, scheelite is like wolframite, with which it is very closely associated, often being a secondary mineral derived from it.

Scheelite occurs at Chesterfield, Massachusetts; Carabarus County, North Carolina; Mammoth district, Nevada; at Turnbull and Huntington, Connecticut, and large crystals at Marlow, Beauce County, Quebec.

Stolzite is the lead tungstate isomorphous with scheelite.

WULFENITE

Wulfenite. — Molybdate of lead, PbMoO_4 ; $\text{PbO} = 60.7$, $\text{MoO}_3 = 39.3$; Tetragonal; Type, Tetragonal Polar; $c = 1.5777$; $001 \wedge 101 = 57^\circ 37'$; $111 \wedge 111 = 80^\circ 22'$; $102 \wedge \bar{1}02 = 76^\circ 31'$; Common forms, n (111), u (102), c (001), m (110), f (320); Cleavage, 111 good, e and s (113) less so; Brittle; Fracture, uneven; $H. = 2.75-3$; $G. = 6.7-7$; Color, various shades of yellow, red, or green; Streak, yellowish white; Luster, adamantine to resinous; Transparent to translucent; $\omega_r = 2.402$; $\epsilon_r = 2.304$; $\omega - \epsilon = .098$; Optically (-).

B.B. — Fuses easily and boils. Reduced with soda on coal yields lead buttons and a lead coat. In the S. Ph. bead it is yellowish green in O. F., clear green in R. F.; this bead shows molybdenum, page 586.

General description. — Crystalline habit, tabular parallel to the base; combinations of the base with several pyramids, as at the Red Cloud mine, Yuma County, Arizona; or the base with short prisms, as at Radersberg, Montana. The tabular crystals are at times very thin and scaly.

Wulfenite is interesting as an example of the tetragonal polar type. Crystals from New Mexico show this polar development of the pyramids, while crystals from Phœnixville, Pennsylvania, have the upper and lower base unequally developed.

Wulfenite is a secondary mineral associated with oxidized lead ores. It is found only in small quantities, though in some localities it occurs in sufficient amounts to constitute an ore of molybdenum.

PART III

CHAPTER I

DESCRIPTION OF THE INSTRUMENTS, REAGENTS, AND CHEMICAL TESTS USED IN THE BLOWPIPE TABLE FOR THE DETERMINATION OF THE MINERAL SPECIES

VERY little apparatus and few reagents are necessary for the blowpipe determination of the common minerals. While elaborate apparatus and mechanical blowpipes have been devised, equally as good results can be obtained by the careful worker with but few and very simple instruments; the success of blowpipe work will depend upon the care and skill of the worker rather than upon the elaborateness of the instruments used.

The blowpipe is by far the most important of all the instruments required. It is in constant use and takes part in almost every experiment. The style of blowpipe to be recommended is that known as the Freiberg model, Fig. 524. This model possesses a trumpet mouthpiece, either of hard rubber or horn, with which blowing may be continued for a long time with very little, if any, fatigue. A trumpet mouthpiece is not necessary, but it involves considerable muscular energy to keep the lips closed around a tube inserted in the mouth, with the necessary air pressure on the cheeks, to yield a strong and constant blast. Where both kinds of mouthpieces have been used there will never be any doubt that the trumpet style will be the one chosen. The shaft **B** may vary in length according to the desire and convenience of the individual, but as manufactured it is about 23 cm. long. Freiberg blowpipes are fitted with platinum tips; this is expensive, but necessary where much work is to be done. Some dealers furnish a spun tip, which is always very thin at the point, so

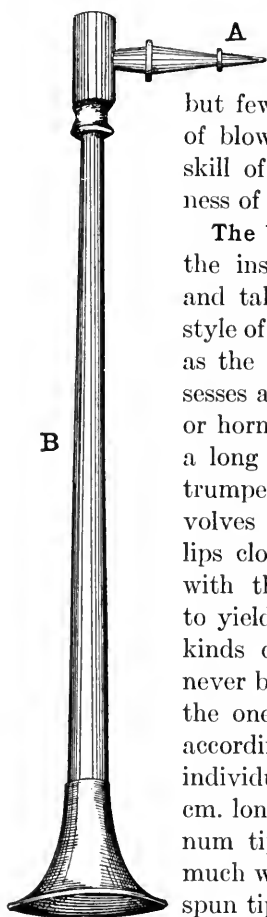

FIG. 524.

thin, in fact, that it will not hold its shape and is very liable to split or crack with but little use, and become worthless. The tip **A** should be thick at the very end, with a smoothly drilled hole of 0.5 mm. diameter. The tip should always be kept clean of dust and when in use yield a well-pointed symmetrical flame at right angles to the shaft, and should under no circumstances be used as a probe to stir or turn the assay.

Burner.—As the fuel used in laboratories and under ordinary circumstances is gas, the Bunsen burner will be used. It is constructed as in Fig. 525, stands 13 cm. high, with an orifice **a**, near the base of the tube, to admit air, which mixes with the gas entering at **b**; this mixture passes up through the tube **c** to be burned at the top. When the orifice **a** is open the flame should be nearly colorless, and should not deposit soot upon any object held in the upper portion of the flame. This colorless or light blue

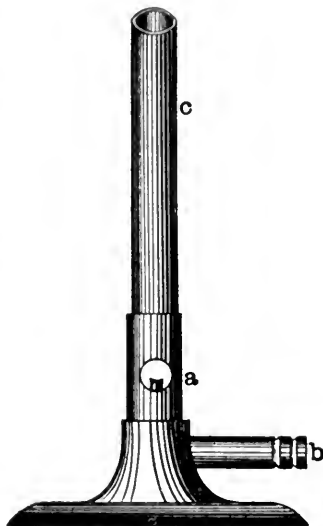

FIG. 525. — The Bunsen Burner.

flame is used to boil test tubes, heat glass tubes, for fusion with the fluxes, or for any experiment where a moderate heat only is required. The substance being heated should be held near the top of the flame, which is by far the hottest portion, and not near the top of the burner tube, as the beginner is always inclined to do. When the orifice **a** is closed and no air is allowed to enter and mix with the gas as it passes up,

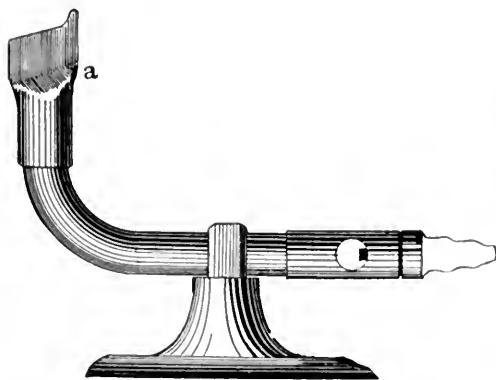

FIG. 526. — The Blowpipe Burner.

the flame will be yellow and yield a thick deposit of soot upon any object that may be held in it; while this flame is useless

for ordinary purposes, it is the flame always used with the blowpipe. It is better to have two burners, one the Bunsen burner as just described, and another, a modified burner, as in Fig. 526. This burner is fitted with a special cap *a* which flattens the flame in the direction of the blast. This cap simply pushes on the top of the burner tube and is easily removed, when the burner may be used in the ordinary way. For convenience in use and ease in blowing, this modified burner should stand not more than 8 cm. high.

Where gas is not to be had, as in field work and prospecting, the paraffine candle will take the place of the blowpipe burner, or a kerosene oil lamp, with a flat wick, will furnish more heat and larger charges may be used. For heating test tubes the alcohol lamp is easily carried and yields a hot, colorless flame, which deposits no soot.

Before testing substances in the blowpipe flame it is necessary to thoroughly understand the difference between the oxidizing flame, always designated the O. F., and the reducing flame, designated the R. F. The student must practice blowing these two flames until a pure flame is obtained in each case, which can be kept constant and can be continued for some time with ease and without exertion.

Structure of the flames. — Light the Bunsen burner, open the orifice and admit air to mix with the gas, have the cock opened until the flame stands about 7 cm. high. Immediately above the tube of the burner will be seen a conical-shaped area, *a*, Fig. 527. This cone is formed by the upward pressure of the gas. Here the flame is hollow, the gas has not yet ignited, and there is little or no heat. If a platinum wire be pushed quickly across this cone, it will become red-hot on either side of this area and in the center will remain dark for some little time. Surrounding this area like a mantle is the inner blue cone *b*, Fig. 527, where the ignited gas is being decomposed; here it contains a large proportion of carbon monoxide, which burning to carbon dioxide colors the flame blue. Carbon monoxide has a strong affinity for oxygen; thus this blue mantle will reduce a large number of compounds when held in it. The most effective reducing portion of the blue cone is just below the tip; the substance to be reduced is held so as to be completely surrounded by the blue flame.



FIG. 527.

The third area *c*, a large purplish cone inclosing the blue mantle, is formed by the heated products of combustion mixed with air, which rushes into the flame from all sides. Area *c* is oxidizing, as substances held in it are raised to a high temperature and while heated come in contact with the oxygen of the air. The hottest portion is immediately outside the blue mantle. In heating test tubes and other large objects they should always be held above the blue cone and never down near the tube of the burner.

The areas of the O. F. as produced with the blowpipe are very similar to those of the Bunsen burner. To produce the O. F. grasp the blowpipe in the right hand with the first and second fingers above, the third and fourth fingers below the shaft of the instrument, with the thumb braced up toward the mouthpiece. In this position a firm pressure may be applied to the mouthpiece, a very material aid in keeping the flow of air constant, and at the same time the blowpipe will not slip through the hand. With the hand in the position described, place the lips against the mouthpiece, fill the cheeks with air from the lungs; while the air from the cheeks is passing slowly through the blowpipe take another breath through the nose. With each breath taken keep the tension on the cheek muscles as nearly constant as possible. With a little practice the constant draft through the blowpipe can be continued almost indefinitely with but little exertion.

Having practiced the breathing as described, place the forearm, about halfway from the elbow, against the edge of the desk. The lighted burner should be placed to suit this position and with the narrow slot in the cap parallel to the edge of the desk, slanting down to the left. Place the tip of the blowpipe over the slot, covering half of it, and 5 mm. above the cap. Blow a strong constant draft through the blowpipe parallel to the slot. The flame will be directed down and to the left, by the draft, as in Fig. 528. It should be about 3 cm. long, sharp-pointed, with a well-defined inner blue cone *a* corresponding to the blue mantle of the Bunsen burner flame. It should burn steadily without sputtering or hissing, and should contain no yellow stripes. If it is irregular, forked, or hisses, the tip is probably imperfect, contains particles of dust, the orifice

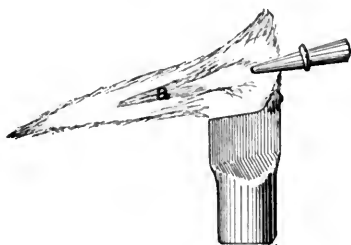

FIG. 528. — The O. F.

is rough, or the draft has been directed against the cap of the burner. All of these must be looked to, until all irregularities of flame are corrected. The length of the flame may be regulated by the position of the platinum tip. If a short flame is required, the tip is pushed a little farther over the slot, and when a long flame is needed the tip is withdrawn, when the flame will shorten or lengthen as the case may be.

The O. F. is used to oxidize substances; for this use the object is held beyond the tip of the blue cone. It must be remembered that the blue cone is formed by burning carbon monoxide, which is reducing, therefore the blue cone must not come in contact with the substance being oxidized. The O. F. is used for testing the fusibility of minerals, testing for flame colorations, and, as it is the hottest flame, in general where a high temperature is required.

To test the temperature of the O. F. take a piece of platinum wire 0.1 mm. in diameter, bend 5 mm. of the end at right angles; holding the wire in the forceps, place it in the flame just so that the extremity touches the tip of the blue cone, with the bent portion parallel to the draft and pointing in the direction of the blowpipe. If the conditions are right, the wire will be seen to shorten and a small globule of fused platinum form on the end. Platinum fuses at a temperature of 1755° C. This temperature must have been reached in the small flame or the globule could not have formed. It will also be seen that it is not the largest flame, but a small well-pointed flame which fuses the wire the more quickly.

The reducing flame, R. F. — It is only necessary to turn the gas up somewhat and withdraw the blowpipe tip until the point is just over the edge of the burner and somewhat higher than when blowing the O. F. The entire flame will be deflected by the draft to the left and a little below the horizontal.

The R. F. is composed of burning hydrocarbons and carbon monoxide and colored with particles of glowing carbon, all of which are reducing agents. The R. F. will reduce many oxides to a lower state of oxidation. If red oxide of iron, Fe_2O_3 , be held in it for only a short time it will be reduced to the protoxide, FeO , thus $\text{Fe}_2\text{O}_3 + \text{CO} = 2\text{FeO} + \text{CO}_2$; one third of the oxygen will be taken up by the R. F. If the FeO be held in a pure O. F. it will pass back to Fe_2O_3 . In all such cases a portion of the oxygen is at the command of the operator; it can be taken away or added to the substance according to the flame used.

Another class of oxides when treated in the R. F. is reduced di-

rectly to metal, thus $\text{PbO} + \text{CO} = \text{Pb} + \text{CO}_2$, which again may be oxidized by the O. F. The substance to be reduced should be completely covered by the flame. In a flickering, unsteady flame, where the assay is alternately covered by the R. F. and then exposed to the oxygen of the air, there is reduction, then oxidation, and in this way the operation may be prolonged indefinitely, in fact good results never obtained.

Coal and its use. — Charcoal is used as a support for substances to be tested, either in the O. F. or R. F., and when used with the R. F. materially aids the reduction; as a reducing agent it is mixed directly with the assay. The best coal is that from light woods, as bass and willow; such coal contains a small amount of ash and is a better non-conductor. It can be held in the fingers while in use for a long time without discomfort. It is sawn in lengths of 12 cm. with a square cross section 2 cm. wide; coals of this shape are economical, as all four sides can be used. They should be dry, free of cracks, burn without snapping or cracking, and yield a light flocculent ash, which is easily blown away. A single piece of coal will last for a long time, if after each experiment the surface is either filed or scraped clean with the spatula. In treating an assay on coal a cavity is made with the steel coal borer, near the end of the coal; the depth of the cavity will depend upon the character of the experiment. If a reduction is required, the hole is made rather deep, 3 to 5 mm., with steep walls. If an oxidizing reaction, the cavity should be shallow, only sufficient to support the assay. In heating the assay, the coal is held between the first finger and thumb, with its long axis parallel to the blast, slightly tilted toward the flame, as in Fig. 529. In this position the coal protects the hand,

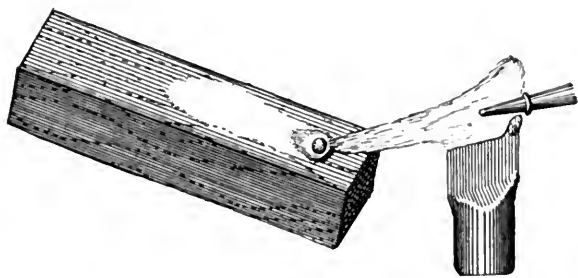

FIG. 529. — Position of Assay on the Coal.

while the draft from the blowpipe will sweep any volatile compounds over the outer end of the coal, where they may collect as coats.

Substances are either heated alone on coal or mixed with a flux to aid the reaction. When heated alone the following phenomena may occur: (1) It **volatilizes**, disappears as a vapor. Volatility must not be confounded with (2) **decrepitation**, where the mineral is thrown off the coal by crackling due to the evolution of gases in cavities causing the mineral to explode. (3) A **coat** may form on the cooler portion of the coal. Metallic vapors driven from the assay come in contact with the oxygen of the air, are oxidized, and settle on the coal, forming coats. (4) Some oxides and compounds are **reduced to metal** when heated along on coal, as Cu, Pb, Sn, Ag, Au, Pt all yield metallic globules, which again upon further heating may volatilize and yield a coat, according to the metal reduced. (5) **Magnetism**, in the case of compounds of iron, the assay may become magnetic; nickel and cobalt when reduced to metal will also be magnetic. (6) **Fusion**, the fragment becomes rounded on the edges or if easily fused forms a spherical globule. (7) **Odors**, as of a burning match, very characteristic of sulphur dioxide; arsenic, selenium, and tellurium also yield odors. (8) **Flame coloration**, the vapors of some metals when burning color the flame, as antimony, zinc, copper, or lead.

Illustration. — In a shallow cavity on coal place some oxide of lead, then holding the coal as directed, blow a short, hot R. F., covering the assay with the flame. It will be seen to fuse first, then little globules of metallic lead will appear, which grow in size until all the oxide is reduced to metal. Change the flame to the O. F., holding the globule just beyond the tip of the blue cone. The metallic lead will boil, the vapors of lead coloring the flame an azure-blue. If the O. F. is continued, the globule will volatilize entirely; the hot metallic vapor will combine with the oxygen of the air and settle on the coal beyond the assay, forming a yellow oxide of lead coat.

Roasting is a metallurgical term, used when either sulphur, arsenic, antimony, or other volatile compounds are either burned or driven off an ore by heat and oxidation. In blowpipe work roasting is in some cases a necessary operation preliminary to reduction on coal or testing with the fluxes. The substance to be roasted is ground to a fine powder, spread out in a thin layer, in a broad shallow cavity on coal, then heated very gently with the O. F. The assay should be carefully watched and not allowed to fuse, as fusion will prevent the air from coming in contact with each particle. If the assay has been fused, it should be powdered again, returned to

the coal, and the roasting continued. The assay is stirred from time to time or turned over with the spatula until all parts are brought in contact with the flame and air. If sulphates and arsenates are present, the O. F. and R. F. should be used alternately. When white fumes no longer escape or the odor of sulphur dioxide is no longer perceptible, the roasting is completed; the residue remaining, generally speaking, is an oxide, and is in condition for use in subsequent bead or reduction tests with the fluxes.

Illustration. — Spread finely ground pyrite, FeS_2 , in a thin layer over a shallow cavity on coal, heat gently in the O. F., but not hot enough to fuse it. Bluish fumes of SO_2 , identified by the odor, will arise as the result of oxidation; the assay will blacken from the formation of the magnetic oxide of iron, Fe_3O_4 , which may be proven with the magnet. If the roasting is completed and the oxidation continued, the final product will be the red oxide of iron, Fe_2O_3 , which is not magnetic.

Platinum wire, .4 mm. in diameter, is used to support fine powder in testing for flame colorations, for fusing silicates with soda (Na_2CO_3), but especially as a support for the borax and salt of phosphorus beads, in testing for the bead colorations, so characteristic of many oxides. For this purpose the wire is held in the platinum wire holder, Fig. 530, the free end is bent in a loop as nearly circular as possible 4 mm. in diameter. To make the borax bead, heat the loop of wire in the O. F.; while hot touch it to the powdered borax, or to a grain of borax of suitable size, then fuse it in the O. F. until all bubbles have disappeared, and the bead is clear and colorless when cold. Sufficient borax should be used to fill the loop and form a spherical bead when cold. Oxides are dissolved in the borax bead by touching the hot bead to the oxide, when some of it will stick to it. It is then heated once more in the O. F. until all the little particles seen floating in the fused borax have disappeared and the bead is clear and transparent. If oxide of manganese is used, the bead when cold will be colored violet-red. In viewing a bead it should be held up to the light of a window, or with a white background; never hold it between the eye and the yellow flame of the burner. If the bead is dark and opaque, an excess of oxide has been dissolved, and the color will appear only after it has been flattened with a gentle pressure with



FIG. 530.

the hammer while it is still plastic; or better still, make a fresh bead and dissolve less oxide in it. It is always better to use a very small amount of material at a time and work up to the color by several additions, examining the bead after each addition, than to at once saturate the bead. After an examination of the color produced in the O. F. the same bead is now held in the R. F., so that it is completely covered, on all sides, by the flame, and in this way protected from the oxygen of the air. The manganese sesquioxide, Mn_2O_3 , which colored it violet-red in the O. F., will be slowly reduced to manganese protoxide, MnO , which has no perceptible coloring effect in borax. The bead when cold and completely reduced will be clear and colorless. Highly charged beads may assume a light violet color due to oxidation while cooling. They should be cooled quickly by pressing them while still hot on the anvil with the hammer. This same bead may be again oxidized, when it will become violet-red. For practice in handling the flames the student should alternately oxidize and reduce it several times.

Salt of phosphorus, $NaNH_4HPO_4 \cdot 4H_2O$, is used in the bead tests in the same way as borax; the two are known as the glass fluxes. Upon first heating the salt boils violently, due to the large quantity of water it contains; for this reason the bead must be built up by installments, heating after each addition until boiling ceases and a clear colorless glass remains. During the fusion the composition has been changed by the loss of water and ammonia; sodium, metaphosphate remains, $NaPO_3$; this is the S. Ph. bead. Its use is the same as the borax bead.

Platinum forceps are used to hold fragments of minerals in the O. F. either to test their fusibility or for a flame coloration. The most convenient model, Fig. 531, is made of steel nickel plated; one end is the ordinary steel forceps used in picking up hot beads, etc.;



FIG. 531.

the other end is self-holding and platinum-tipped. Minerals with luster which fuse easily, or those which

reduce to metal, should not be held in the platinum, as they will alloy with it and the forceps will be ruined.

Illustration. — Heat a slender fragment of strontionite ($SrCO_3$) in a small well-pointed O. F., holding the fragment of mineral in such a manner that it projects out beyond the platinum tips and

may be held at the tip of the blue cone where it will be heated very hot without actually heating the forceps at all. When sufficiently hot, it will color the flame intensely red. In the testing of minerals for fusibility a slender fragment, not larger than 1 mm. in thickness at the point, should be selected; if the mineral fuses with difficulty, very fine-pointed pieces should be tested before it is decided that the mineral is infusible. Select a suitable piece of almandite garnet, hold it as in testing for flame coloration, at the tip of the blue cone, care being taken that it projects beyond the forceps. Almandite fuses at 3; its edges will become rounded and at the highest temperature the entire end of the fragment will be globular. Select a piece of orthoclase of the standard size (fusibility 5); after heating in the same way it will be found that the edges are rounded only; fine needle-like pieces will fuse to a globule on the end.

Fusibility is determined by comparison with a mineral selected as a standard. The scale of fusibility was arranged by Von Kobell and modified by Penfield. Specimens of the standard minerals should be tested.

Fusibility 1, Stibnite, large fragments fuse in the yellow gas flame.

Fusibility 2, Chalcopyrite, small fragments fuse to a globule in the yellow flame.

Fusibility 3, Almandite, coarse fragments become globular in the O. F.

Fusibility 4, Actinolite, coarse edges are rounded in the O. F.

Fusibility 5, Orthoclase, needle-like fragments become globular in O. F.

Fusibility 6, Bronzite, needle-like fragments become rounded on the point.

While heating a mineral for its fusibility, it should be carefully watched and the following noted: whether it **intumescs**, that is, swells and bubbles when it fuses; whether it **swells or curls** without fusing—**exfoliates**; whether it becomes **enameled** or is **glassy** and clear after fusion; or whether it fuses to a **blebby, vesicular glass**. All these conditions are quite important in the determination of minerals.

Hammer and anvil.—Any small hammer will serve, as it is used only to break small pieces of minerals and to flatten malleable buttons.

A block of hardened steel 3 cm. square serves as an anvil; both hammer and anvil should be well polished and kept free of rust.

Agate mortar and pestle. — Used to grind minerals to a fine powder, and in the washing of assays for malleable buttons. A fragment of the mineral to be ground is wrapped in paper and broken down to a coarse powder with the hammer on the anvil. A small amount is then placed in the mortar and ground. In testing for solubility, gelatinization, and in fusion with the fluxes all minerals must be very finely ground.

Magnifying glass. — Used to examine small crystals, to search washed slags for malleable buttons, and to examine fragments of minerals after heating to determine their fusibility.

Magnet. — A small bar magnet shaped like a cold-chisel, used in testing the magnetism of minerals and slags.

Files triangular and flat. — Used for testing the hardness of minerals and cleaning coals.

GLASSWARE

Dropping Bottle. — Used to drop cobalt solution or to drop water in mixing charges for reduction on coal. The ordinary medicine dropper, Fig. 532, is convenient,

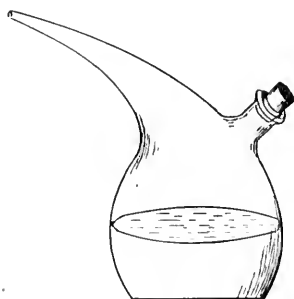

FIG. 532. — Dropper.

or one can be quickly made by fitting a small bottle with a perforated cork through which a glass tube extends to near the bottom of the bottle, which is cut off 2 cm. above the cork. In use the cork is grasped between the thumb and second finger, while the first finger is placed over the open end of the glass tube when the cork and tube is withdrawn from the bottle; by releasing the pressure of the finger on the top of the tube, the liquid contained will fall slowly out, a drop at a time.

Test tubes. — Used for chemical tests in the wet analysis, for boiling acids, etc. A convenient size 15 mm. in diameter by 15 cm. long.

Filter funnels. — Glass funnels 5 cm. in diameter and cut filter papers 7 cm. in diameter. In use the papers are folded twice, forming a quadrant, one side of which is opened, and the cone thus formed is fitted in the funnel and dampened with water, when it is ready for use. The solution to be filtered is carefully poured into the paper, never filling it more than two thirds full. After the

solution has drained off, the solids are washed by dropping distilled water from the wash bottle around the edge of the paper; after it drains, repeat several times, when the solids may be considered practically free of salts carried in solution, at least free enough for qualitative tests.

Closed tubes or matrasses are made from hard glass tubing 6 mm. inside diameter. The tube is cut in 15 cm. lengths; these are heated in the middle in the Bunsen burner flame until the glass softens, constantly turning the tube; draw apart quickly until the two ends part. Reheat the end that has been drawn out, while soft cut off the extremity with an old pair of scissors, then fuse in the flame until rounded. They should be cooled slowly or annealed to prevent cracking when they are reheated while in use.

The closed tube is used to heat substances out of contact with the oxygen of the air, therefore there is little or no oxidation. Substances to be heated should be in small fragments or coarse powder, and simply dropped to



FIG. 533. — Matrass Holder.

the bottom. The tube, held in the **matrass holder**, Fig. 533, is heated with the O. F. gently at first, finally increasing the heat until the walls of the tube are fused. During the heating the following phenomena are looked for.

a. Water. — Some minerals contain water of crystallization or water of constitution; the first is driven off at a comparatively low temperature, the latter at a much higher temperature. This water will collect in little drops or as a mistlike coat on the cold walls of the upper end of the tube. It is needless to say that care must always be taken that the open end is always cold enough to condense the water. Heat a small piece of calamine ($Zn_2SiO_4 \cdot H_2O$).

b. Sublimates are solids condensed on the cold walls of the tube, formed of vapors driven from the mineral being heated. They may be **white** or **colored**. Heat some arsenopyrite ($FeSAs$), gently at first, when a **bright red** sublimate of sulphide of arsenic will form, becoming brownish red as it collects. On continued heating crystals of metallic arsenic will form a little below the sulphide, finally forming a complete band or **metallic mirror** of arsenic.

c. Odors caused by escaping gases and acid fumes.

d. Charring. — The substance blackens and usually emits a

bituminous odor. If the black residue burns or glows in the air when heated, the presence of carbon or organic matter may be assumed.

e. Change of color. — Characteristic of some oxides.

Open tube. — Pieces of hard glass tube 15 cm. long and 7 mm. inside diameter are used to heat coarsely powdered minerals in a current of air, oxidizing the volatile compounds as they are driven off by the heat. Substances to be tested are placed about 3 cm. from the end. The tube is held in the matrass holder; the O. F. is directed on the glass directly under the coarse powder, at the same time the tube is held diagonally across the flame and 45° from the perpendicular. The object is to obtain a draft of air to furnish the oxygen and to also carry the vapors up through the tube, where they may condense as sublimates or pass out as gases. Heat is applied gently at first, increasing the temperature to full redness.

a. The escaping gas smells like a burning sulphur match, due to **sulphur dioxide**. **Arsenic** and **selenium** also yield characteristic odors.

Illustration. — Heat some coarsely powdered pyrite in the open tube. Here a sublimate of sulphur is not obtained, as in the closed tube, but the sulphur combines with the oxygen of the air passing through the tube, forming SO_2 , which escapes at the upper end, yielding the odor.

b. Sublimates. — They may be white or colored as in the closed tube.

Illustration. — Heat a small fragment of arsenic in an open tube. The sublimate formed is not a metallic mirror as in the closed tube, but a white sublimate of trioxide of arsenic (As_2O_3) which is composed of octahedral crystals. Examine with the magnifying glass.

Watch glasses to hold powdered mineral, soda, borax, etc., and one or more porcelain evaporating dishes will be required to concentrate solutions and to gelatinize powdered minerals. If the under sides of these porcelain dishes are unglazed, they will serve as **streak tablets** also.

Blue Glass. — A darkly colored piece of cobalt glass 5 cm. square used for the absorption of sodium light in testing for potassium. Bottles of clear glass with plane parallel sides, and filled with solutions of potassium permanganates or chrome alum are much better than the blue glass but less convenient for use in the potassium test, see page 563.

REAGENTS

Solid reagents are kept in small salt-mouth bottles from which they are easily removed in small quantities, with a spatula, as required for use. To insure a clean and pure reagent the excess should never be returned to the bottle.

Borax glass, fused sodium baborate, $\text{Na}_2\text{B}_4\text{O}_7$, in granules, the size of rice grains, and also finely powdered borax for use as a flux.

Salt of Phosphorus. — Sodium ammonium hydrogen phosphate, $\text{NaNH}_4\text{HPO}_4 \cdot 4 \text{H}_2\text{O}$. For S. Ph. beads.

Soda, dry sodium carbonate, Na_2CO_3 , used as a flux in the decomposition of silicates. Five parts of soda are mixed with one part of finely powdered mineral and a drop or two of water added to form a paste; this charge is fused on coal or platinum wire until it stops effervescing, when the charge is dissolved in dilute acid.

Potassium bisulphate. — Potassium hydrogen sulphate, KHSO_4 , is used as a component of special fluxes. Upon heating potassium bisulphate loses water, passing over to potassium pyrosulphate, $\text{K}_2\text{S}_2\text{O}_7$; with continued heating SO_3 is driven off as white fumes. The residue is normal potassium sulphate, K_2SO_4 .

Potassium nitrate, KNO_3 , is used in small quantities as an oxidizing agent.

Copper oxide, CuO , finely powdered, is used in the dry test for chlorine.

Test lead, both granular and sheet, free of silver, is used in the cupellation test for silver.

Tin, granular and sheet, is used in the reduction of salts in solution, also as a reducing agent when fused with the borax, or S. Ph. bead on coal.

Silver, a bright silver surface, as a coin, is used in the test for sulphur.

Bone ash. Used in making the cupels in the separation of silver and gold from the lead button.

Turner's flux. — Made by mixing one part of powdered fluor-spar with four parts of potassium bisulphate. Used in the decomposition of borates in testing for the boric acid flame.

Lithium flux. — Made by mixing one part of powdered fluor-spar with one and one half parts of potassium bisulphate. Used in the decomposition of silicates in testing for a lithium flame.

Potassium flux. — Made by mixing three parts of powdered calcium carbonate and one of ammonium chloride. Used in

the decomposition of silicates in testing for the potassium flame. The flux should be tested for the potassium flame to insure its purity.

Von Kobell's flux. — Made by mixing equal parts of potassium iodide and flowers of sulphur. Used in testing for the lead and bismuth iodide coats on coal.

Blue litmus paper. Used in testing the acidity of fumes and of the water yielded in the closed tube.

Turmeric paper. Used in the alkaline test and also for the detection of boric acid and zirconium.

REAGENTS USED IN SOLUTION

Wet reagents are made up in the strengths indicated in each instance. They should be kept in bottles with tightly fitting ground glass stoppers. The water used is distilled.

Hydrochloric acid, used in two strengths. Concentrated as obtained from the supply houses is spc. 1.19 to 1.20, containing about 39 per cent. HCl. The dilute acid is made by adding an equal volume of water to the concentrated; this yields a solution of HCl a little stronger than five times normal, 5 n.

Sulphuric acid, H_2SO_4 , the concentrated as obtained is spc. 1.84 and is 36 times normal. The dilute is made by pouring slowly one volume of concentrated acid into six volumes of water; the diluted acid will be approximately five times normal, 5 n.

Nitric acid. — The concentrated acid is spc. 1.42, and contains 69 per cent. HNO_3 , equal to 16 times normal. The dilute acid is made by mixing 5 volumes of acid with 11 volumes of water; the diluted acid will be approximately 5 n.

Acetic acid, CH_3COOH , used in some wet tests, as in the tests for chromates.

Hydrogen sulphide, H_2S , is generated by treating ferrous sulphide with sulphuric acid, $FeS + H_2SO_4 = FeSO_4 + H_2S$. A bottle may be used as the generator; the acid is poured in the thistle tube or funnel, the lower end of which extends to the bottom of the bottle. The H_2S gas generator is led off through the bent tube. It is either used as a gas or absorbed in water. The water solution is kept in a bottle, thus avoiding the use of the generator in each test.

Sodium hydroxide, NaOH, 200 gm. of the sticks are dissolved in water and diluted to a liter. The solution will be 5 n. One cc. of

this solution will neutralize 1 cc. of the dilute acids. It is used to precipitate hydroxides.

Sodium phosphate, disodium phosphate, $\text{Na}_2\text{HPO}_4 \cdot 12\text{H}_2\text{O}$. Dissolve 171 gm. in water and dilute to a liter. This solution is used in the test for magnesium.

Ammonia, ammonium hydroxide, NH_4OH . Strong ammonia is spc. .90, it contains 29 per cent. NH_3 . One part of the strong solution diluted with 3 parts of water will yield a solution nearly 5 n. 1 cc. of this solution will neutralize 1 cc. of the dilute acids. Ammonia is used in many wet tests and to precipitate hydroxides.

Ammonium sulphide, $(\text{NH}_4)_2\text{S}$, made by saturating the dilute ammonium solution with H_2S . It is used to precipitate metallic sulphides and in some cases hydroxides.

Ammonium carbonate, $(\text{NH}_4)_2\text{CO}_3$. — To make a 5 n. solution, dissolve 200 gms. of commercial ammonium carbonate in 350 cc. of the dilute ammonia, and dilute to a liter. It is used to precipitate metallic carbonates.

Ammonium oxalate, $(\text{NH}_4)_2\text{C}_2\text{O}_4 \cdot 2\text{H}_2\text{O}$. — To make a normal solution dissolve 80 gm. in water and dilute to one liter. Used in testing for calcium.

Ammonium molybdate, $(\text{NH}_4)_2\text{MoO}_4$. — Dissolve 60 gm. of molybdic trioxide, MoO_3 , in 440 cc. of water and 60 cc. of strong ammonia. This solution is slowly poured with constant stirring into 250 cc. concentrated nitric acid previously diluted with 250 cc. of water. Let the solution stand for 24 hours, when it is either filtered or decanted. On further standing the molybdic acid gradually separates, forming a light yellow crust on the sides and bottom of the bottle, thus losing its strength on standing. This reagent is used to precipitate phosphoric acid.

Barium hydroxide, $\text{Ba}(\text{OH})_2 \cdot 8\text{H}_2\text{O}$. — A $\frac{1}{5}$ n. solution is used; dissolve 31 gm. in one liter of water. Used in the detection of carbon dioxide.

Barium chloride, $\text{BaCl}_2 \cdot 2\text{H}_2\text{O}$. — To make a normal solution dissolve 122 gm. in a liter of water. The solution is used in the tests for sulphates.

Lead acetate, $\text{Pb}(\text{CH}_3\text{COO})_2 \cdot 3\text{H}_2\text{O}$. — To make a normal solution dissolve 189 gm. in a liter of water. It is used in the detection of chromates.

Silver nitrate, AgNO_3 . — To make $\frac{1}{5}$ normal solution 34 gm. in a liter of water. It is used in the test for chlorine.

Ferrous sulphate, $\text{FeSO}_4 \cdot 7\text{H}_2\text{O}$. — To make a normal solu-

tion dissolve 139 gm. in a liter of water. It is used in the test for nitrates.

Cobalt nitrate, $\text{Co}(\text{NO}_3)_2$.—10 gm. are dissolved in 100 cc. of water. A supply is kept in a dropping bottle for use. Various compounds after ignition in the O. F. with cobalt solution yield characteristic colors, as alumina and zinc oxide.

IDENTIFICATION TESTS OF THE ELEMENTS

Included here are the blowpipe tests and the most important chemical reactions used in the identification of minerals. The order followed is to a large extent that of Mendeleeff's periodic system. The common elements and therefore the most important are placed first in each group.

THE ALKALIES

Sodium, Na; **Potassium**, K; **Lithium**, Li; and the rare elements **Rubidium**, Rb; **Cæsium**, Cs.

Owing to the great solubility of all salts of the alkali metals there is no simple direct test to prove their presence in a mineral in the wet way. From a blowpipe standpoint they all agree in yielding distinguishing flame colorations. When present only in small amounts, as is generally the case of rubidium and caesium, the spectroscope is necessary for their identification with certainty. Salts of the alkali metals, except borates, phosphates, silicates, and some salts of rare acids, when strongly ignited in O. F. yield an alkaline reaction with turmeric paper.

Example.—Ignite some powdered sodium chloride, NaCl , in the O. F. on platinum wire, moisten the wire and touch it to the powder, when enough will stick to it for the test. Place on a clean watch glass a small square, 1 cm., of turmeric paper. When the ignited salt has cooled it is placed on the paper and a single drop of water from a dropper is dropped on the ignited powder. The water dissolves the alkaline salt, and on being absorbed by the paper colors it reddish brown. In some cases it may be necessary to allow the fragment to rest on the paper for a few minutes, when the alkaline reaction will appear directly under the fragment, where it is in contact with the paper. In salts that are not alkaline before ignition the reaction is due to a decomposition of the salt by the

heat of the O. F. ; the acid radicle is partially or completely volatilized.

Potassium, K. Atomic weight, 39.10. Fusing point, 62.5° C.

a. Compounds of potassium, except silicates, phosphates, and borates, when heated on wire or in the forceps yield a light, violet flame. When sodium or lithium is present, the potassium flame is masked. In such cases the flame is viewed through the blue cobalt glass, which if dark enough absorbs the sodium and lithium flames but allows the violet rays of potassium to pass through. In place of the blue glass a clear bottle, with flat sides, filled with a solution of potassium permanganate, or better still, a solution of chrome alum, will serve the same purpose. The required depth of color is obtained by experimenting with solutions of different strengths. After a time the permanganate, by decomposition, deposits a brown film on the walls of the bottle ; from this fault a solution of chrome alum is free. Viewed through all these media the potassium flame is violet-red.

Illustration. — Heat some sylvite, KCl, on platinum wire in O. F. and observe the violet flame, also through the blue glass.

b. In case of silicates, borates, and phosphates, the finely ground mineral is mixed to a stiff paste with water and four parts of potassium flux. It is then fused in the blue mantle of the Bunsen burner flame ; the violet-red of potassium will appear through the blue glass.

Illustration. — Powder some orthoclase, KAlSi_3O_8 , in the agate mortar ; add four parts of potassium flux and water to a stiff paste. Hold the mixture on platinum wire in the Bunsen burner flame about halfway up and on the side ; observe the potassium flame through the blue glass, when it will appear violet-red.

c. **Platinum chloride test.** — If to a slightly acid solution of potassium salts hydrochloro-platinic acid, H_2PtCl_6 , is added, the solution evaporated nearly to dryness, then diluted with alcohol, the potassium will separate as yellow octahedral crystals of potassium platinic chloride, K_2PtCl_6 . The corresponding sodium salt is soluble in alcohol. Ammonium, lithium, rubidium, and cesium yield similar precipitates insoluble in alcohol.

Illustration. — Dissolve a little sylvite in water, add a drop of HCl, and precipitate with K_2PtCl_6 and alcohol.

Insoluble silicates must be fused with soda. Fuse 1 part of finely powdered orthoclase with 5 parts of soda, either make several beads on wire, or fuse on platinum foil. The fusion is boiled in water,

acidified with HCl, evaporated to dryness on the bath in a small porcelain dish; boil the residue with 2 cc. of water, cool, dilute with 2 cc. alcohol and filter through a small filter; to the filtrate one drop of dilute HCl is added and the potassium is precipitated as K_2PtCl_6 .

Sodium, Na. — Atomic weight 23. Fusing point, $95.6^\circ C$.

a. Sodium compounds when heated in the O. F. yield an intense yellow flame. This test is so delicate that great care and judgment must be exercised in its use, before deciding that sodium is present in sufficient amount to be considered as a constituent of the mineral. The flame must therefore be both strong and persistent.

Illustration. — Heat some powdered halite, NaCl, on platinum wire.

Lithium, Li. Atomic weight, 6.93. Fusing point, $186^\circ C$.

a. Most lithium compounds when heated in the O. F. either on wire or in the forceps yield a very bright crimson flame. Strontium is another metal that yields a crimson flame, very much like that of lithium, and care must be taken not to confound the two. Sodium generally occurs with lithium; after heating for some time the yellow flame of sodium may mask the lithium flame. If the fused powder or fragment is momentarily removed from the flame, then brought in contact with it again slowly, the pure crimson flame of lithium will appear, first unmixed with yellow; as lithium salts are more volatile than sodium salts they color the flame first.

Illustration. — Heat a small fragment of lepidolite in the forceps, in O. F., observe the crimson flame of lithium, and finally also the yellow flame of sodium.

b. Some minerals, especially silicates, do not readily yield a lithium flame when heated alone; before deciding that a mineral does not contain lithium, it should be mixed with 4 parts of lithium flux; the mixture is fused on wire in the Bunsen burner flame.

Illustration. — Powdered spodumene, $LiAl(SiO_3)_2$, is mixed to a stiff paste with water and 4 parts of lithium flux and fused on wire in the Bunsen burner flame. After the flux has had time to decompose the silicate the crimson flame of lithium will appear.

Rubidium, Rb. Atomic weight, 85.45. Fusing point, $28.5^\circ C$.

Caesium, Cs. Atomic weight, 132.1. Fusing point, $26.37^\circ C$.

Both very rare metals; they occur in small quantities in lepidolite, and some sphalerites. They may be separated from other metals and silicates, as is potassium; the precipitate is tested with the spectroscope.

Ammonium, NH_4 .

Ammonia, NH_3 , is a gas at ordinary temperatures; when dissolved in water it forms ammonium hydroxide, NH_4OH , commonly called ammonia. It is driven from the water solution by heat as NH_3 , which possesses a very marked odor, reacts as a base in forming salts, which in their chemical behavior are very similar to the salts of potassium, except its salts are volatile, and for that reason ammonium is termed the volatile alkali.

a. If a compound containing ammonium is boiled in a test tube with sodium hydroxide, ammonia will be liberated and carried off in the steam, when it is detected by the odor; or if a glass rod moistened with HCl is held over the tube, a white cloud of ammonium chloride, NH_4Cl , will appear.

GROUP II: THE ALKALI EARTHS

Barium, strontium, and calcium are precipitated from alkaline solutions as carbonates, phosphates, oxalates, or borates. They are alike also in yielding before the blowpipe flame colorations. Magnesium, generally placed in this group, yields no flame coloration, and its salts are more soluble. They all agree in that, if their salts, except the silicates, borates, and phosphates, are ignited, they yield an alkaline reaction with turmeric paper.

Barium, Ba. Atomic weight, 137.37. Fusing point, 850°C .

a. Flame. — If a mineral containing barium, except silicates, is heated at the tip of blue cone in the O. F., it will yield a yellowish green flame. Borates and phosphates also yield green flames that must not be mistaken for barium. Silicates must be tested as in *b*.

b. Wet test. — Barium salts in solution yield a white precipitate with sulphuric acid. This precipitate when filtered out and dried will yield a yellowish green flame.

Silicates and insoluble compounds are fused with four parts of soda, boiled in water and filtered. The residue will contain the barium as barium carbonate. This is dissolved in a few drops of dilute HCl . The solution allowed to run through the filter is collected in a test tube. In this solution H_2SO_4 will precipitate the barium as before.

Illustration. — Heat a small fragment of witherite, BaCO_3 , in O. F. After continued heating observe the yellowish green flame. Place the ignited fragment on turmeric paper; moisten with a drop of water. It will react alkaline. Dissolve a little powdered mineral

in dilute HCl; add a drop of dilute H_2SO_4 ; a white precipitate of $BaSO_4$ will appear. Filter and test this precipitate on wire for the barium flame.

Strontium, Sr. Atomic weight, 87.6. Fusing point, $900^\circ C$.

a. Flame. — Strontium minerals when heated in the O. F. yield a bright crimson flame. This will be more marked if after the first heating the fragment is moistened with HCl. Care must be taken not to confuse the strontium flame with the lithium flame, or in case HCl has been used, with the calcium flame, which is yellowish red. Silicates are fused with soda as in the case of barium.

b. Wet test. — Strontium in solution yields a white precipitate of strontium sulphate, $SrSO_4$. Insoluble compounds are fused with soda and treated as under barium, § *b*. The precipitate of sulphates may in some cases contain both strontium and barium. In testing it on wire the strontium flame will appear first. After moistening with HCl strontium will disappear first and the green of barium after continued heating.

Illustration. — Heat a fragment of strontianite, $SrCO_3$, in the forceps in the O. F., and observe the bright crimson flame. Place the ignited fragment on turmeric paper, after moistening; it will react alkaline. Dissolve a small fragment in 2 cc. of dilute HCl; add a drop of H_2SO_4 , when a white precipitate of strontium sulphate, $SrSO_4$, will appear; filter and test it for the flame.

Calcium, Ca. Atomic weight, 40.07. Fusing point, $780^\circ C$.

a. Calcium salts, especially after moistening with HCl, yield before the blowpipe a yellowish red flame. When the mineral fails to yield the calcium flame, calcium should be separated in the wet way, as in *b*.

b. Wet test. — Calcium sulphate is more soluble than either barium or strontium sulphates and is not precipitated from dilute solutions. This condition may be used to make a qualitative separation of calcium from barium and strontium. The solution of the mineral is obtained by fusion with soda, as under barium; the solution is diluted and dilute H_2SO_4 is added until a white precipitate no longer forms; boil and filter; the calcium will now be found in the filtrate, from which it is separated by evaporation to very small volume and precipitated with concentrated sulphuric acid. The white precipitate of calcium sulphate, $CaSO_4$, is tested for the calcium flame, or concentrated solutions before precipitation may be tested directly by moistening a platinum wire with it and holding it in the Bunsen burner flame.

Illustration. — Heat a small fragment of calcite, CaCO_3 , in the O. F.; at first there will be no flame coloration, but as the fragment becomes incandescent a very delicately colored flame will appear. After cooling, moisten the same fragment with HCl and heat again; the yellowish red flame of calcium will at once appear. Place the ignited fragment on turmeric paper and moisten with a drop of water; the paper will show the alkaline reaction.

Radium, Ra. Atomic weight, 226.4.

Radium is not contained in any mineral in amounts sufficiently large to yield blowpipe tests. In its chemical properties it is like barium, and may be concentrated and separated with barium, from which it is separated by fractional crystallization. It differs from barium in yielding a crimson flame.

Magnesium, Mg. Atomic weight, 24.32. Fusing point, 632.6°C .

a. Cobalt solution affords the only blowpipe test for magnesium. A large number of light-colored minerals containing magnesium become pink or flesh-colored after ignition with cobalt solution. This test at best is not very satisfactory, and especially as it cannot be applied to minerals dark in color, or those which become dark upon ignition.

b. **Alkaline test.** — Some minerals containing magnesium when strongly ignited and placed on turmeric paper will yield the alkaline reaction. In most cases the reaction is not very marked; the fragment must be allowed to rest on the paper for several minutes, and even then the alkaline reaction may be found only directly under the fragment.

c. **Wet test.** — Magnesium is a component of a large number of silicates and other difficultly soluble minerals, in which it is associated with iron, aluminium, calcium, etc., and from which the magnesium must be separated before the wet test can be applied.

The insoluble mineral is finely powdered and fused either on wire or platinum foil with four parts of soda; the fusion is dissolved in dilute HCl , and evaporated in a small porcelain dish to dryness on the bath. The dry residue is moistened with HCl , then dilute with 5 cc. of water; stir and let stand on the bath for a minute or so. The residue remaining insoluble will be silica, and is filtered out; the filtrate is collected in a test tube, boiled with 3 or 4 drops of nitric acid to oxidize the iron to ferric iron; 3 drops of concentrated HCl are now added, the solution shaken and neutralized with ammonia, when iron and aluminium are precipitated as hydroxides; after filtering, the filtrate, containing the magnesium

and other alkali earths, is collected in a test tube; to this solution a few drops of ammonia are added, then ammonium oxalate; boil and let the precipitated calcium, barium, or strontium oxalates settle, when the clear solution is tested with another drop of ammonium oxalate to insure complete precipitation. The filtrate from the calcium oxalate should be concentrated, either on the bath or by gently boiling in a test tube to 2 cc., when if it is not perfectly clear it is filtered through a small filter. 3 cc. of strong ammonia is now added, then 20 drops of sodium phosphate, shaking the solution between each drop; let stand in the cold. A white crystalline precipitate, ammonium magnesium phosphate, $\text{NH}_4\text{MgPO}_4 \cdot 6 \text{H}_2\text{O}$, indicates the presence of magnesium.

Illustration. — Heat a fragment of brucite, $\text{Mg}(\text{OH})_2$, in O. F.; after cooling moisten with a drop of cobalt solution and ignite again in the O. F. strongly for some time; after cooling observe that it has turned a delicate pink or flesh color. Moisten the ignited fragment on turmeric paper and observe that the alkaline reaction is rather weak. Dissolve some of the mineral in HCl and precipitate magnesium as directed in § c above.

GROUP III

Metals precipitated as hydroxides by ammonia and by hydrogen sulphide in alkaline solutions.

I. Common elements, aluminium and chromium.

II. Rare elements, beryllium, thorium, zirconium, yttrium, cerium, lanthanum, didymium, titanium, tantalum, columbium.

Aluminium, Al. Atomic weight, 27.1. Fusing point, 657°C .

a. Cobalt solution. — Light-colored minerals are ignited in the O. F., after cooling are moistened with cobalt solution, and again strongly ignited in the O. F., when if they contain much aluminium the ignited residue will be bright blue on cooling. Silica and minerals which fuse will yield a blue color which is not due to aluminium, but the glassy slag is colored blue with oxide of cobalt. Very hard minerals as topaz must be finely ground before ignition.

Illustration. — Heat a small splinter of cyanite, Al_2SiO_5 . In O. F. when cool moisten with a drop of cobalt solution and ignite again in a hot O. F., holding the fragment just without the tip of the blue cone; after cooling, the blue color due to the presence of aluminium will appear.

b. Wet test. — Insoluble compounds and silicates are treated as

under magnesia, § c. The hydroxides precipitated with ammonia containing the aluminium are scraped from the paper and boiled in a test tube with sodium hydrate, the aluminium hydroxide dissolves, and the insoluble hydroxides, generally iron, are filtered off and washed. The filtrate is acidified with HCl and the aluminium is reprecipitated with ammonia, filtered, dried, ignited, and tested for the blue color with cobalt solution.

Chromium, Cr. Atomic weight, 52.1. Fusing point, 1515° C.

a. Bead test. — When oxide of chromium is dissolved in the borax bead in O. F. it will color the bead yellow while hot, becoming greenish yellow on cooling. If more oxide is dissolved in the bead, it becomes red while hot, yellowish green while cooling, and finally green when cold.

In the S. Ph. bead, when in sufficient quantity, chromium yields a fine emerald green in both flames. Vanadium yields a green bead very similar to chromium, except in S. Ph., in O. F. The vanadium bead is yellow when cold. As there are several oxides which yield green beads, in case of doubt the wet test for chromium must be applied.

Illustration. — Use Cr_2O_3 , and a very pure O. F. to obtain the yellow described above, otherwise the bead will be green on cooling.

b. Wet test. — The very finely ground mineral is fused on wire with four parts of soda and two parts of borax; while the fused bead is still hot it is touched to a small grain of potassium nitrate and fused once more in the O. F. If much chromium is present, the cold bead will be yellow, due to the sodium chromate, Na_2CrO_4 , formed in the oxidation with KNO_3 . The fusion is dissolved in 2 cc. of water and acidified with acetic acid; if not now clear it is filtered. To the clear solution 3 drops of lead acetate are added, when, if chromium is present, a bright yellow precipitate of lead chromate, PbCrO_4 , will form; this may be filtered off and tested for the green bead.

Illustration. — Fuse powdered chromite, FeO , Cr_2O_3 , and proceed as directed above.

Titanium, Ti. Atomic weight, 48.1. Fusing point, 3000° C.

a. Bead test. — The distinctive bead reaction for titanium is the violet color, in R. F. and S. Ph. when cold, especially marked when reduced with tin on coal. When this bead reaction is obscured by the presence of other oxides, the wet test must be applied.

Illustration. — Use very finely ground rutile, TiO_2 , and heat the

bead in the O. F. until all the particles have dissolved, then in the R. F. for considerable time, when it will be a light violet when cold. In the treatment with tin, the bead is removed from the wire and placed in a shallow cavity beside a piece of tin of about half its size, then fused in the R. F. for some time; the tin and S. Ph. beads will fuse, but remain distinct, simply sticking to each other and rolling around in contact during the fusion. The fused tin oxidizes at the expense of the oxygen combined with the titanium, which is reduced to Ti_2O_3 , coloring the bead violet when cold.

b. Wet test. — Insoluble substances are finely powdered, made into a stiff paste with water and 6 parts soda and a little borax, and thoroughly fused either on coal or platinum foil. The fusion is dissolved in 2 cc. of concentrated HCl. Titanium is now present in solution as TiO_2 ; if much iron is present, the solution will be yellow from the ferric chloride. Granulated tin is now added, which dissolves in the HCl, forming stannous chloride, $SnCl_2$, and liberates hydrogen. As the hydrogen reduces the ferric chloride to ferrous chloride the yellow color due to iron disappears, then the TiO_2 is reduced to Ti_2O_3 , and the solution assumes a violet color, especially on standing.

c. Hydrogen peroxide test. — If the amount of titanium present is less than 3 per cent., the above tests are not sufficiently delicate. The substance is fused as directed above, but is dissolved in 3 cc. dilute H_2SO_4 by boiling in a test tube; when dissolved, dilute with water to 10 cc. and add 2 cc. of hydrogen peroxide solution, when if titanium is present the solution will assume a golden yellow and if much is present an orange color.

Illustration. — Use powdered rutile and proceed with the tests as directed.

Columbium (Niobium) Cb(Nb). Atomic weight, 93.5. Fusing point, $1950^\circ C$.

a. Wet test. — Columbium compounds are very insoluble in acids, and must be thoroughly fused with borax or potassium bisulphate on wire or foil; the fusion is then dissolved in concentrated HCl as in the case of titanium, when granular zinc is added and the solution is reduced in the same way. If columbium is present, it will become blue. In the reduction if titanium is present also, the solution will be violet first, as titanium is the first to reduce; then the columbium will be reduced, and the solution will be finally blue. Tungsten is another metal which yields blue solutions after reduction with tin; for distinguishing tests see § *b*, p. 587.

Illustration. — For above test use columbite $(\text{Fe}, \text{Mn})\text{Cb}_2\text{O}_6$.

Tantalum, Ta. — Atomic weight, 181.5. Fusing point, 2250°C . There is no blowpipe test.

a. Wet test. — Tantalum is always associated with columbium, from which it is separated with difficulty. It does not, however, yield the blue solution on reduction with tin. Columbium and tantalum may be extracted from minerals and separated from each other by the following method. The finely ground mineral is fused with 5 parts of acid potassium fluoride, the fusion is pulverized and extracted in a platinum dish with boiling water, containing a little hydrofluoric acid, evaporated nearly to dryness, and dissolved in the least possible quantity of boiling water; on cooling, tantalum will separate as needle-like crystals of potassium tantalum fluoride, K_2TaF_7 , which are brownish when dry. Columbium will separate as potassium columbium fluoride, K_2CbF_7 , from the solution on concentration as tablets.

Zirconium, Zr. Atomic weight, 90.6. Fusing point, 1500°C . Blowpipe tests, none.

a. Wet test. — The mineral is fused with 4 parts soda, the fusion dissolved in a few drops of concentrated HCl , diluted with three volumes of water. A piece of turmeric paper is moistened with this diluted solution, and then gently dried, when if zirconium is present, it will turn the paper reddish brown to orange-red, the depth of color depending upon the amount of zirconium present. Titanium if present must be reduced with tin, or Ti also will yield a reddish brown color. Molybdates and boric acid also yield, under similar conditions, a brown color with turmeric paper, and must be distinguished by their special tests from zirconium.

Illustration. — Use powdered zircon, ZrSiO_4 .

Beryllium (Glucinum), Be. Atomic weight, 9.1. Fusing point, 960°C .

Blowpipe tests, none.

a. Wet test. — Beryllium is separated from silicates in the same way as aluminium, § *b*. After treating the hydroxides with sodium hydroxide and filtering, beryllium will be found in the filtrate with the aluminium and is separated from it by diluting the solution with water and boiling, when beryllium is reprecipitated as a white flocculent hydroxide, $\text{Be}(\text{OH})_2$; the aluminium stays in solution.

Illustration. — Beryl, $\text{Be}_3\text{Al}_2(\text{SiO}_3)_6$, may be used for this separation.

Cerium, Ce. Atomic weight, 140.25. Fusing point, 623°C .

Associated with cerium chemically is a group of elements, distinguished and separated from each other with difficulty; they are known as the

Rare Earths

Their hydroxides are precipitated by either ammonia or sodium hydroxide, which separates them from the alkali earths. From the method of separation, the solubility of their oxalates, they are divided into two groups:

Group I. Gadolinite earths or Yttrium earths	Group II. Cerite earths
Yttrium, Y., Atomic weight 89.	Lanthanum, La., Atomic weight 139.
Scandium, Sc., Atomic weight 44.1	Cerium, Ce., Atomic weight 140.5
Samarium, Sm., Atomic weight 150.4	Praseodymium, Pr., Atomic weight 140.6
Gadolinium, Gd., Atomic weight 157.3	Neodymium, Nd., Atomic weight 144.3
Terbium, Tr., Atomic weight 159.2	Thorium, Th., Atomic weight 232.4
Erbium, Er., Atomic weight 167.7	Some doubtful elements may be added to this group
Thulium, Tm., Atomic weight 168.9	
Ytterbium, Yb., Atomic weight 172.	
Dysprosium, Dy., Atomic weight 162.5	

They may be extracted from a mineral as follows. If the mineral is insoluble in acids, it is mixed to a stiff paste with strong sulphuric acid, the paste is heated carefully until the SO_3 fumes are driven off, and then baked hard and dry; the dry mass is pulverized and leached with boiling water until all soluble salts are extracted.

The free acid is neutralized with ammonia. To the hot solution a few cc. of ammonium acetate and a large excess of a boiling saturated solution of ammonium oxalate are added; let cool and stand overnight. The crystalline precipitate is composed of the oxalates of the rare earths with the exception of thorium, which is still in solution; these are filtered, dried, and ignited to the oxides. From the filtrate thorium is precipitated as hydroxide with sodium hydrate. The ignited oxides are dissolved in the least possible quantity of HCl, then saturate this solution with potassium sulphate, let stand, filter, and wash with a strong solution of

potassium sulphate. The precipitate contains the cerium group as sulphates, the filtrate contains the yttrium group. The sulphates of the cerium group may be dissolved in boiling water, to which a little HCl has been added, and reprecipitated as hydroxides, with sodium hydroxide. From the filtrate containing the yttrium group, their hydroxides may also be precipitated with sodium hydroxide.

GROUP IV

Metals which are precipitated with hydrogen sulphide from alkaline solutions as sulphides, but not from acid solutions. Common elements are zinc, manganese, cobalt, nickel, and iron; rare elements are uranium, vanadium, indium, thalium, gallium.

Zinc, Zn. Atomic weight, 65.37. Fusing point, 419° C.

a. Coat. If zinc minerals are mixed in a stiff paste with water, and 4 parts soda and a little coal dust, placed in a shallow cavity on coal and heated in a hot reducing flame, the zinc is reduced (zinc volatilizes at the temperature of reduction so that zinc buttons are not found in the assay upon washing in the mortar), volatilizes, and settles as a zinc oxide coat near the assay, which is straw yellow while hot, becoming white when cold. Zinc minerals are apt to contain cadmium; in such cases the coat will be slightly yellow when cold. At times it is difficult to decide whether a slight coat has been obtained or whether it is only an ash, produced by the burning coal. The coat, however slight, is always accompanied by a bluish border, where the white coat thins out over the coal; and then, too, the ash is easily blown off the coal with a moderate breath.

b. Cobalt solution test. — The zinc coat is now moistened with a drop of cobalt solution, and heated in O. F.; the assay is also heated in the blue cone to volatilize a little more zinc if possible; after cooling, if the coat is zinc oxide, it will be a grass-green, at least in spots. If the assay contains silica or alumina, it will become blue with cobalt solution. This blue color of the assay is, therefore, no indication of zinc. Cobalt solution serves to distinguish the zinc and tin coats, which are very much alike in all other respects, save the zinc coat is grass-green and the tin coat is blue with cobalt solution.

Illustration. — Grind some smithsonite, $ZnCO_3$, mix to a stiff paste with 4 parts soda, 1 part powdered borax, and a little coal dust and water. Heat gently at first in a shallow cavity on coal

until all water is driven off, then in a hot R. F., holding the coal close up to the burner and using the blue portion of an O. F., which is reducing. Note the coat is quite yellow while hot and is surrounded by the bluish border which serves to distinguish a coat of this color and position from an ash. After cooling, the coat will be white. Moisten with cobalt solution and heat carefully in an O. F. so as not to blow the coat off; let cool, when the coat will be grass-green, at least in spots. If the green does not appear, the assay is heated in the R. F. to drive off a little zinc; let cool and the green color will appear.

Manganese, Mn. Atomic weight, 54.93. Fusing point, 1245° C.

a. Bead reactions. — Oxides of manganese when dissolved in either the borax or S. Ph. bead yield in O. F. an amethyst or violet-red color, which becomes colorless in R. F. Small charges should be used at first, as very little manganese will yield an opaque bead reducing in R. F. with difficulty. The color is much lighter in S. Ph. than in borax, and as some silicates are not decomposed in S. Ph., borax will therefore yield the better results.

b. Soda and niter test. — Any compound of manganese when fused with soda on platinum wire in O. F. and again fused with a small grain of niter in the O. F., if manganese is present the bead will be green, bluish-green, or a dark opaque blue according to the amount of manganese present. This is a very delicate test; amounts as low as .1 per cent. can be easily detected. The color is due to the formation of sodium manganate, Na_2MnO_4 .

Illustration. — Use any compound of manganese, as pyrolusite, MnO_2 .

Cobalt, Co. Atomic weight, 58.97. Fusing point, 1530° C.

a. Bead test. — Compounds of cobalt when dissolved in borax or S. Ph. yield in both flames a dark smalt-blue, a very delicate test. If copper or nickel are present they may conceal the cobalt when in small quantities; in this case the borax bead is taken from the wire and reduced beside tin on coal, when copper and nickel are reduced to metal and absorbed by the tin, when if cobalt is present the borax will be blue. See also under nickel.

Illustration. — Use oxide of cobalt. Sulphides, arsenides, and antimonides must be roasted before dissolving in the bead.

Nickel, Ni. Atomic weight, 58.68. Fusing point, 1484° C.

a. Bead reaction. — Oxides of nickel color the borax bead in O. F. a violet, which on cooling becomes brownish, or if highly charged a reddish brown; in R. F. the bead is gray, due to metallic

nickel. The S. Ph. bead is reddish yellow while hot, yellow on cooling in both flames. Small quantities of cobalt and copper will interfere with the bead reactions of nickel. Cobalt and nickel are closely associated in minerals, generally in sulphides and arsenides; in this case the mineral is fused in the R. F. to a round globule and a large proportion of the arsenic and sulphur is roasted off. A piece of borax double the size of the globule is placed beside it on coal and treated with the O. F. a short time, when the color of the borax is observed. If the globule contains iron, nickel, cobalt, and copper, they will be oxidized not all at once, but one at a time in the order mentioned, each in turn imparting its characteristic color to fresh charges of borax. The amount of each metal present can be roughly judged by the number of fresh charges of borax it takes to absorb it. If it takes only two or three beads to remove the cobalt, it is present as a minor component of the arsenide and after the blue of cobalt has disappeared, nickel will oxidize and color the borax reddish brown.

Illustration. — Use a fragment of niccolite, NiAs, which always contains some cobalt, about the size of a rice grain and fuse it on coal in a hot R. F. to a round globule; place some borax beside it and treat with the O. F. The two globules will roll around under the flame in contact, but will remain quite distinct; any cobalt in the arsenide will be oxidized by the O. F. and be absorbed by the borax. Carefully pick the arsenide globule out of the borax, with the steel end of the forceps, and place to one side for future treatment; while still hot pull the borax out with the forceps in a thread; it will be blue from cobalt, or if opaque, some of it is dissolved with fresh borax on wire and the color observed. Return the arsenide globule to the coal after cleaning the cavity of all old borax and repeat the treatment with a fresh supply. After several treatments all cobalt will have been oxidized and the borax will become reddish brown from nickel.

√Iron, Fe. Atomic weight, 55.84. Fusing point, 1600° C.

a. Bead reaction. — Oxides of iron when dissolved in the borax bead in O. F. yield, while hot, a light yellow to dark red color according to the amount present; this becomes colorless, or if well charged, yellow when cold. In R. F. the bead is green, and if well charged a dirty yellowish green on cooling; if reduced beside tin on coal, this bead is a clear bottle green. The moderately charged S. Ph. bead in O. F. is yellowish red while hot, becoming yellow and finally colorless when cold. In R. F. the well-charged bead

is red while hot, yellow while cooling, finally smoky-brown when cold. There are many oxides which interfere with the bead reaction for iron, and there are other elements which yield nearly the same colors. The table of bead reactions on page 594 must be consulted. Bead reactions in combination with the magnetic test below will serve to identify the presence of iron.

b. Magnetism. — Compounds of iron when ground finely and treated on coal in R. F. become magnetic; this is especially so if fused with soda on coal, the fusion washed in the mortar, when the black residue will be magnetic. It must be remembered that cobalt and nickel become magnetic also; however, these, if present, can easily be detected by their bead reactions. In testing the residue after reduction it should be cold and in fine powder; spread out on a white paper, the magnet is passed carefully over it; if magnetic, particles should move to the magnet. Particles may stick to the magnet from moisture or other causes and still not be magnetic.

Illustration. — For the above tests use hematite, Fe_2O_3 .

Uranium, U. Atomic weight, 238.5.

a. Bead reaction. — The colors of uranium oxides in borax are like iron; in S. Ph. uranium oxide is yellow while hot, yellowish green on cooling in O. F.; in R. F. the bead is a fine green when cold. Chromium, vanadium, and molybdenum also give green beads in R. F.

b. Wet test. — Dissolve the powdered mineral in HCl, or if insoluble first fuse with soda, nearly neutralize the free acid with ammonia, then add a solution of sodium carbonate until a precipitate ceases to form, then half as much more, let stand. Uranium at first precipitated is redissolved in the excess of sodium carbonate and will be found on filtering in the filtrate. Acidify the filtrate with HCl, boil to expel CO_2 , add an excess of ammonia, when yellow ammonium urinate, $(\text{NH}_4)_2\text{U}_2\text{O}_7$, will precipitate. This is filtered and tested for the bead reaction as above, or dissolved in 1 cc. of dilute H_2SO_4 , a small scrap of zinc added, which reduces the uranium, yielding at first blue, turning finally to green. If the green solution is poured off the zinc, in another test tube, and hydrogen peroxide added, then sodium carbonate in excess, the solution will assume a cherry-red color; this is a very delicate test for uranium.

Illustration. — Use powdered uraninite.

Vanadium, V. — Atomic weight, 51. Fusing point, 1680°C .

a. Bead reaction. — When dissolved in borax, oxides of vanadium are yellow to yellowish green in O. F. while hot, nearly colorless when cold. In R. F. a dirty green when hot and a fine green when cold. The S. Ph. bead is yellow in O. F., fine green in R. F. when cold.

b. Wet test. — The well-roasted mineral is fused with 4 parts soda and 2 of niter, the fusion is dissolved in boiling water and any insoluble residue filtered off; the soluble alkali vanadates will be found in the filtrate; this is acidified with acetic acid, and lead acetate added, which will precipitate the vanadium as lead vanadate, $Pb_3(VO_4)_2$, yellow at first, but soon turning white; this precipitate may be tested in the S. Ph. bead as above. Molybdenum and chromium will also yield yellow precipitates with lead acetate, and green beads with S. Ph. To separate vanadium from these, the solution of alkali vanadate from the soda fusion is not acidified with acetic acid, but solid ammonium chloride is added to almost saturation, when upon standing for some time ammonium metavanadate, NH_4VO_3 , will separate as a slightly yellowish crystalline precipitate; filter and wash with ammonium chloride solution. If this precipitate is heated in a porcelain crucible, the ammonia is driven off, leaving a red residue, pentoxide of vanadium, V_2O_5 . If it is wished to further test this residue, it may be dissolved in HCl and reduced with zinc; the solution, yellow at first, quickly becomes green and finally blue; the blue poured off the zinc, and hydrogen peroxide added, becomes red.

Illustration. — Use oxide of vanadium.

Thallium, Tl. Atomic weight, 204. Fusing point, 301.7° C.

Indium, In. Atomic weight, 114.8. Fusing point, 155.3° C.

Gallium, Ga. Atomic weight, 69.9. Fusing point, 30.15° C.

These three very rare elements are associated in some sphalerites. Of the three thallium alone occurs in large enough quantities to characterize two rare minerals as thallium minerals, crookesite and lorandite.

They are best detected with the spectroscope.

Thallium yields a bright green flame. Its salts are volatile, and when in R. F. on coal it yields a white oxide coat. If mixed with von Kobell's flux, it yields a lemon-yellow coat very similar to lead; the bright green flame will, however, distinguish it from lead.

GROUP, V

Metals which are precipitated from acid solution by hydrogen sulphide as sulphides, and the sulphides of which are insoluble in ammonium sulphide.

Common metals: silver, mercury, lead, bismuth, copper, and cadmium.

Rare metals: palladium, rhodium, osmium, ruthenium.

Silver, Ag. Atomic weight, 107.87. Fusing point, 955° C.

a. Reduction. — Compounds containing silver when fused on coal with 4 parts soda in R. F. yield metallic silver. If the silver button does not appear bright, it may be heated on coal in the O. F. beside borax; the base metals will oxidize first; their oxides are dissolved by the borax, leaving the silver button bright.

When the amount of silver in a mineral is small, considerable of the powdered mineral should be mixed with 2 volumes of test lead and one volume of powdered borax; this charge is placed in a deep cavity in the coal and heated with the R. F., gently at first, until the lead is fused; the reduction is continued for a couple of minutes, shaking the coal now and then while under the flame to collect the lead in one globule. All silver and other reduced metals the charge may have contained will be collected in the lead globule. The O. F. is now used to refine the lead, by oxidizing arsenic, antimony, or any easily oxidized elements the lead may contain. When the lead begins to boil freely, the assay is allowed to cool, the lead is picked out and cleaned of slag by hammering on the anvil. A cupel is now prepared by cutting a cavity 6 mm. deep and 12 mm. in diameter near the end of a firm piece of coal; this is packed full of dry bone ash and pressed down with the large end of the agate pestle, giving a twist to the pestle at the last which will leave the concave surface smooth and hard. The loose bone ash is blown off and the cupel is ignited in the O. F. to drive off all moisture. The clean lead button is placed on the cupel and fused with the R. F.; after the lead is fused and the cupel is hot, a well-pointed O. F. is directed on the lead. The flame should be no hotter than is necessary to keep the lead fused and the bone ash directly underneath it well heated or it will not absorb the oxide of lead as it is formed. It is better to roll the lead by tilting the cupel to fresh portions of the surface from time to time, but the lead should never be allowed to freeze or solidify, once the oxidation has commenced. The experiment

must be carried to the end without interruption. In cupellation the lead is oxidized, the oxide is both volatilized and absorbed by the bone ash. As the percentage of lead decreases, the globule becomes more spherical and a thin iridescent film of oxide of lead is constantly moving over its surface; as the last of the lead is driven off, this film disappears, the button brightens, and a distinct change in color is noticed. This change must be carefully watched and oxidation stopped, as silver is volatile also, and considerable of it may be lost if the heating is continued after all the lead has been oxidized. The silver button will be white unless it contains considerable gold, when it will be yellowish. It will also contain the metals of the platinum group if the ore contained any. If the ore contained no silver, the lead will disappear entirely in the bone ash, but the spot where it disappeared should always be examined with a lens.

b. Wet test. — The powdered mineral is dissolved in nitric acid, the solution cooled and filtered; a drop of HCl is added, when if silver is present a white precipitate of silver chloride, AgCl, is formed, becoming dark on exposure to light. Lead and mercurous mercury will also yield white chlorides. Lead chloride is soluble in hot water; if the solution containing the precipitate is boiled, lead chloride will redissolve; or it is filtered and washed with boiling water, when if the precipitate dissolves, it is lead; when insoluble, ammonia is poured over it on the filter; if it blackens it is mercury; if there is no effect it is silver.

Illustration. — Any ore containing silver may be used for these tests.

Mercury, Hg. Atomic weight, 200.6. Fusing point, -38.85° C.

a. The substance is mixed in powder with 3 parts dry soda, placed in a closed tube, with a little pure dry soda placed on top of the charge. The tube is now heated in the burner flame or O. F. The mercury is reduced and volatilized, forming a gray sublimate on the cold walls of the tube. This sublimate is composed of minute globules of mercury. They may be rubbed together, poured out in a watch glass, and examined with a lens.

Illustration. — Use cinnabar, HgS.

Lead, Pb. Atomic weight, 206.9. Fusing point, 327° C.

a. Reduction test. — Lead is reduced to a malleable gray metal with soda and borax in R. F. on coal. The powdered mineral is mixed to a stiff paste with water, 4 parts soda, 1 part borax, and some coal dust; this charge is fused in R. F. on coal; the resulting

fusion is cut away from the coal and ground in the mortar under water. If pressure is used in the grinding the lead buttons will be flattened out in thin scales, when if a gentle stream of water is allowed to run in the mortar, the coal and slag, being much lighter than the lead buttons, will be carried away. When very little lead is present, the end of the pestle must be examined for metallic streaks; also the coal, for the yellow oxide coat (see below). The button of lead may be further tested by dissolving it in nitric acid and adding a drop of H_2SO_4 , when if it is lead a white precipitate of lead sulphate will form.

b. Yellow lead coat. — Minerals and compounds containing lead are roasted in the O. F. for a time; then reduced with the R. F. lead is reduced to metal, and if the heat is continued, volatilizes, forming a yellow oxide of lead coat. The yellow coat may, when the mineral contains much sulphur, be masked by a white sulphate coat; if the white coat is heated in the O. F. until it glows, the white coat will be reduced and on cooling will appear yellow.

c. Bismuth yields a yellow oxide coat which at times is distinguished from the lead coat with difficulty. In this case the powdered mineral is mixed with an equal volume of von Kobell's flux and treated with a moderately hot R. F. on coal, when if lead is present, a lemon-yellow iodide of lead coat will form, at a distance from the assay. Under similar conditions bismuth will yield a brick-red coat.

Illustration. — For the above tests use galena, PbS.

Bismuth, Bi. Atomic weight, 208. Fusing point, $269^\circ C$.

a. Coat. — Bismuth compounds, when heated in a moderately hot R. F. with soda and borax as in the case of lead, yield metallic globules, which, however, are not malleable. If the flame is continued, the metal volatilizes, forming a yellow oxide coat.

b. Von Kobell's test. — The finely powdered mineral is mixed with 2 parts of von Kobell's flux and treated with a moderately hot R. F. on coal; if bismuth is present, a brick-red iodide of bismuth coat will form at a considerable distance from the assay, inside of which there may also form a yellow oxide coat. This brick-red coat is a very characteristic test for bismuth and serves to distinguish it from lead.

Illustration. — Use bismuth oxide.

Copper, Cu. Atomic weight, 63.57. Fusing point, $1084^\circ C$.

a. Flame test. — A very delicate test for copper is to roast the mineral in O. F. on coal; the charge is allowed to cool and is then

moistened with a drop of HCl; heated once more in a small R. F., a bright azure-blue copper chloride flame will appear, which on long heating, if much copper is present, will give way to the green flame of copper oxide. The azure-blue flame with care will detect .1 per cent. of copper.

b. Bead test. — Oxide of copper when dissolved in borax yields in O. F. a green bead while hot, becoming blue when cold. In R. F., if it contains much oxide, the bead is opaque red when cold, due to cuprous oxide, Cu_2O ; if the reduction is continued, the cuprous oxide is reduced to metallic copper and the borax is colorless, especially if reduced on coal. In S. Ph. the colors are the same as in borax.

c. Reduction test. — Copper is reduced from its oxidized compounds with soda and borax in R. F. on coal, yielding red buttons and scales of malleable metal on washing the charge in the mortar. Sulphides and ores containing arsenic and antimony should be roasted before mixing with soda.

Illustration. — Powder some chalcopyrite, spread it out in a thin layer on coal, and heat it with an O. F., but do not fuse it; turn it over and continue the roasting until the odor of SO_2 has disappeared. Allow it to cool and moisten with a drop of HCl, heat now in the R. F.; a bright azure-blue flame proves the presence of copper.

Mix the roasted mineral with 4 parts soda, 1 part borax, and some coal dust to a stiff paste with a little water. The charge is reduced on coal, and is finally heated in the blue cone of the O.F. until thoroughly fused, when it is cut away from the coal and ground in the mortar under water. The copper buttons or scales, being malleable, will not grind down, but the slag and coal will be broken up and washed away, leaving the red scales of metallic copper.

Cadmium, Cd. Atomic weight, 112.4. Fusing point, 321.7°C .

a. Coat. — Cadmium compounds when heated with soda and borax in R. F. are reduced; on continued heating, the metal is volatilized, yielding an orange-yellow oxide of cadmium coat. Cadmium when associated with lead may be difficult to detect as a coat; in such cases the coat is scraped from the coal and treated in a closed tube with the O. F.; care is taken not to heat the tube hot enough to drive off lead or zinc; a yellow ring of cadmium oxide will form just above the assay. If much is present, it will form a metallic mirror.

Platinum, Pt. Atomic weight, 195. Fusing point, 1755° C.

Platinum is reduced from an ore and cupeled as described under silver, p. 578. If much platinum is present, the lead button will solidify before all the lead is driven off. The remaining lead may be removed by treatment in O. F. beside borax on coal; the lead is oxidized and absorbed by the borax. The remaining button will contain the silver, gold, and the metals of the platinum group; this is dissolved in nitro-hydrochloric acid, solid ammonium chloride is added, and the solution evaporated nearly to dryness; it is now diluted with alcohol and the yellow ammonium platonic chloride, NH_4PtCl_6 , is filtered out, washed with alcohol, carefully ignited, when the platinum will remain as sponge platinum, with other metals of the platinum group. If there was any gold in the button, it will be found in the filtrate from the ammonium platonic chloride.

Other Metals of the Platinum Group

Ruthenium, Ru. Atomic weight, 101.7 Fusing point, 1950° C.

Rhodium, Rh. Atomic weight, 102.9. Fusing point, 2000° C.

Palladium, Pd. Atomic weight, 106.7. Fusing point, 1586° C.

Osmium, Os. Atomic weight, 190.9. Fusing point, 2500° C.

Iridium, Ir. Atomic weight, 193.1. Fusing point, 1950° C.

All the above five metals are rare. They are associated in small quantities with some native platinum. Their separation is difficult and there are no blowpipe or simple wet tests by means of which small quantities may be conveniently detected in minerals.

GROUP VI

Metals, the sulphides of which are insoluble in dilute acids, but soluble in alkali sulphides.

Common elements: gold, platinum, tin, antimony, arsenic.

Rare elements: germanium, iridium, molybdenum, tungsten, tellurium, selenium.

Gold, Au. Atomic weight, 197.2. Fusing point, 1065° C.

a. Gold is generally present as metallic gold, but in such fine particles as not to be discernible by the eye or hand lens. It is necessary to collect, or concentrate, the gold from a pound or more of ore. The ore is ground to pass an 80-mesh sieve; after all the sample has been sifted, the sieve is examined for particles

of gold which have been flattened in the grinding; if any are found, they are added to the ground sample. The sample is placed in a tin or iron pan 2 in. deep and 8 in. across; 2 cc. of mercury is added, the pan is filled with water, taken in the hands, and shaken with a circular motion; by this motion the sample is stratified and the materials will be arranged according to their specific gravity, with the heavier particles in the bottom, where the gold will come in contact with the mercury and form an amalgam. With care the light materials may be allowed to flow over the side of the pan, especially if a stream of water is running through it at the same time it is shaken with a circular motion, throwing the light particles to the top. If the heavy concentrates contain pyrite, they should be dried, and roasted to drive off the sulphur, then ground and repanned with the same mercury. Finally all heavy material together with the mercury is washed in the mortar and ground under water, also allowing a stream to flow through it, which is so regulated as to carry the light materials, as they are ground, over the edge, leaving in a very short time the clean bright mercury which contains the gold. The mercury is poured on a thick piece of chamois or buckskin, folded up, and most of the mercury is squeezed through; if the chamois is thick and tight, only mercury will pass through, the gold amalgam remaining. This is transferred to a porcelain crucible, heated gently at first, and finally to redness, to volatilize the mercury; or if there is only a small quantity of amalgam, the mercury may be driven off with the O. F. on coal. In either case the residue contains gold and silver, which is collected on a small piece of sheet lead; and to insure enough silver for parting, pure silver to twice the amount of the residue is folded with it in the lead and fused in the O. F.; then cupeled as in the case of silver, p. 578. The button of gold and silver if large is flattened on the anvil, and parted; that is, the gold is separated from the silver. After flattening the button it is heated with 2 cc. of dilute nitric acid in a porcelain crucible; heating serves to start the reaction and then it is allowed to proceed slowly. The nitric acid dissolves the silver, leaving the gold as a black-looking powder or a brownish, spongy mass. The nitric acid is decanted. The gold is treated in the same way with strong nitric acid, decanted, and washed with water. If the sample was weighed in the beginning and the operation carried through with care, the gold residue may be weighed and will represent a fair assay of the ore. When only a

qualitative test for gold is required, the residue from the mercury is tested in the wet way as below; cupellation and parting are not necessary.

Ores and minerals containing considerable gold may be treated in the same manner as the silver assay, p. 578.

b. Wet test. — The powdered mineral, or residue of gold from the cupel, is dissolved in nitro-hydrochloric acid, diluted and filtered, the solution evaporated nearly to dryness to drive off free acid, diluted with water, and a solution of ferrous sulphate added, when the gold will be reduced to the metallic state and precipitated in the form of a brown powder, but if the quantity is very small, the solution will be colored bluish or purple by the fine particles of suspended gold.

Tin, Sn. Atomic weight, 119. Fusing point, 232° C.

a. Reduction test. — The powdered mineral, if a sulphide, is first roasted, then mixed with soda, borax, and coal dust, reduced and washed as described under lead, p. 579. The tin globules are white and malleable. They may be mistaken for silver, from which they are distinguished by yielding insoluble white metastannic acid on heating in a test tube with HNO_3 ; also see coat below.

On heating in the R. F. the charge is well fused, but the flame should not be continued long, as tin after reduction is easily volatilized, when no buttons will be found in the charge, upon washing in the mortar.

b. Tin is easily volatile, forming an oxide coat, very near the assay, yellow while hot and white on cooling. In making the reduction test the coal should always be examined for a coat. Tin and zinc coats are much alike in their position on the coal, color, and both are volatilized with difficulty. If the tin coat is moistened with cobalt solution and heated with the O. F., it will become blue or bluish green when cold. A zinc coat will become grass-green.

Illustration. — Use cassiterite, SnO_2 . If the reduction test *a* is heated for a longer time, the tin coat of *b* will appear.

Antimony, Sb. Atomic weight, 120.2. Fusing point, 630° C.

a. Coat. — Compounds of antimony when heated on coal in the R. F. are reduced to metal; in some cases it is necessary to roast the charge in O. F. before reduction, but in all cases the metal after reduction is volatilized, yielding a white oxide coat, Sb_2O_3 , which settles at a considerable distance from the assay.

On the outer edge, where the coat is thin, it appears bluish, due to the black coal showing through the thin white film. The antimony coat is volatile and may be driven from the coal with either flame, but with more difficulty than the arsenic coat, which it very closely resembles. If a well-pointed O. F. about an inch long is blown and the coat brought up quickly to the middle of the flame and in a slanting position, the coat will volatilize and at the same time color the flame a yellowish green. This flame coloration serves to distinguish antimony from arsenic.

Illustration. — Use stibnite, Sb_2S_3 .

Arsenic, As. Atomic weight, 75. Fusing point, $450^\circ C$.

a. Compounds of arsenic when heated in the O. F. on coal oxidize; when heated in R. F. volatilize yielding a white oxide coat, As_2O_3 , which settles on the coal at a distance from the assay. It is very similar to the white coat yielded by antimony, but when treated with the O. F. the flame is not colored green. Arsenical vapors as they rise from the assay, especially after heating in R. F., yield a *garlic-like* odor, very characteristic. In case the mineral contains sulphur, it is mixed with several volumes of soda to retain the sulphur, when the arsenic odor is easily detected.

b. **Arsenic mirror.** — Fusible and volatile compounds of arsenic are mixed with coal dust; infusible compounds must be mixed with soda and coal dust. The mixture, in either case, is placed in the bottom of a narrow closed tube, also a small fragment of coal is placed on top of the charge, the O. F. is now directed upon this fragment of coal first until it glows, then the assay is heated. Arsenic is reduced and condenses as a metallic mirror on the cold walls of the tube. If the amount of arsenic is small, the closed tube should be drawn out at the bottom as represented in Fig. 534, in which *d* is the mirror.

The mirror may be further tested to distinguish it from antimony, in which the bottom of the tube is broken off; the mirror is now heated in the Bunsen flame; the arsenical odor may be detected by quickly smelling the fumes as they escape from the

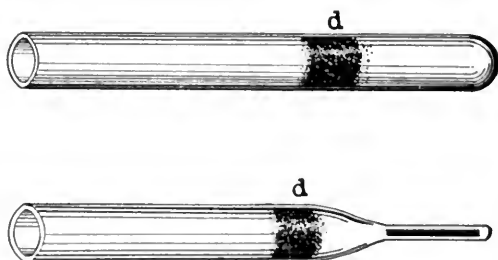

FIG. 534.

open end of the tube. If the fumes are allowed to escape in the Bunsen burner flame they will color it violet; antimony will color it yellowish green.

Compounds of arsenic when mixed with soda and potassium cyanide will yield the mirror in the closed tube.

c. Wet test. — All compounds of arsenic may be tested as follows. The substance is finely ground and mixed with 4 parts soda and 3 of niter, and fused on platinum foil or wire. The fusion is boiled in water to dissolve the sodium arsenate, Na_3AsO_4 , and filtered; the filtrate acidified with HCl, then a solution of magnesium sulphate, and finally strong ammonia in excess is added, the solution is shaken and let stand. Arsenic will separate as ammonium magnesium arsenate, $\text{NH}_4\text{MgAsO}_4 \cdot 6\text{H}_2\text{O}$, which is filtered off, washed with a solution of ammonia, dried, and tested for the mirror as in *b*.

Illustration. — Use arsenopyrite, FeSAs.

Germanium, Ge. Atomic weight, 72.5. Fusing point, 900°C .

Germanium is a very rare element found in only three minerals, argyrodite, euxinite, and canfieldite. In the R. F. it is reduced, then volatilizes, forming an oxide coat, GeO_2 , white near the assay and yellowish at a distance from it. It also has a peculiar glazed appearance. It, however, yields no odor or flame coloration. Germanium when treated as in arsenic, § *b*, yields a mirror.

Molybdenum, Mo. Atomic weight, 96.

a. Bead test. — Molybdic oxide when dissolved in the borax bead is colorless or nearly so in O. F. In R. F. it is brown to black. In S. Ph., O. F., the bead is colorless or nearly so; in R. F. a fine green.

b. Coat. — Some compounds of molybdenum yield on coal an oxide, MoO_3 , coat, yellowish while hot, white on cooling. If the R. F. is brushed over this white coat, it is partially reduced, yielding a very deep blue color. On heating the white coat in O. F. most of it is volatilized; the coal, however, reduces some of it to binoxide, which is non-volatile and remains on the coal as a copper-red film.

c. Flame. — Some compounds of molybdenum when heated in O. F. yield a green flame.

d. Wet test. — If compounds of molybdenum are fused on platinum wire with 3 parts of soda and 3 parts niter, several of these beads are dissolved in a test tube with boiling water. The clear solution is decanted, acidified with HCl, a small piece of

copper foil added and heated slightly, when the molybdenum is reduced, coloring the solution blue. Tungsten is reduced but slightly by copper, but will yield a blue solution with zinc.

Illustration. — Use molybdenite, MoS_2 .

Tungsten (wolframum) W. Atomic weight, 184. Fusing point, 2800°C .

a. Bead test. — Oxide of tungsten when dissolved in the S. Ph. bead in O. F. is colorless or nearly so; in R. F. the moderately charged bead is dirty green while hot and when thoroughly cold is blue.

b. Wet test. — Compounds containing tungsten are dissolved in the S. Ph. bead, removed from the wire, and reduced beside tin on coal. After reduction, it is powdered and dissolved in 1 cc. dilute HCl, when the solution becomes blue, or it may be necessary to heat the solution with powdered tin.

Illustration. — Use wolframite $(\text{Fe.Mn})\text{WO}_4$.

Tellurium, Te. Atomic weight, 127.6. Fusing point, 446°C .

a. Coat. — Tellurides when heated in R. F. on coal yield a white coat of TeO_2 , much like the antimony coat, which also imparts a pale greenish color to the flame.

b. Wet test. — Powdered tellurides when heated in a test tube with 2 or 3 cc. of concentrated H_2SO_4 will color the acid reddish violet.

c. The substance is fused in the closed tube with 3 parts soda and coal dust; after fusion the tube is cooled and water added; if tellurium is present the solution will be reddish violet.

Selenium, Se. Atomic weight, 79.2. Fusing point, 217°C .

a. Odor. — Compounds of selenium when heated in the R. F. on coal yield a very disagreeable but characteristic odor, which is a very delicate test for the element, even in small quantities.

b. Coat and flame. — If there is much Se present when treated as in *a*, a white oxide coat will form, at times bordered with red. The coat when treated with the R. F. volatilizes, coloring the flame an intense azure-blue.

Non-metallic acid elements.

Sulphur, S. Atomic weight, 32.07. Fusing point, 115°C .

a. Odor. — Sulphides when roasted on coal in the O. F. yield sulphur dioxide, SO_2 , which is detected by the characteristic odor, as of a burning sulphur match.

b. Soda test. — Sulphur in any form may be detected by fusing the powdered mineral in R. F. with 4 parts soda and coal dust.

Sodium sulphide, Na_2S , will be formed, soluble in water. The fusion is cut away from the coal and placed on a bright silver surface, a coin will answer, and moistened with a couple of drops of water. The dissolved sodium sulphide attacks the silver, forming a brown or black stain of silver sulphide.

c. Wet test for sulphates. — The substance if insoluble in acid is fused on coal in O. F. with 4 parts of soda, dissolved in boiling water and filtered; to the filtrate, a few drops of barium chloride are added, when, if sulphates are present, a white precipitate of barium sulphate, BaSO_4 , will form.

Illustration. — For tests in *a* and *b*, use pyrite, FeS_2 ; for *c*, use gypsum, $\text{CaSO}_4 \cdot 2\text{H}_2\text{O}$.

Chlorine, Cl. Atomic weight, 35.45. Fusing point, -102°C .

a. Flame test. — Copper oxide is dissolved in the S. Ph. bead. The hot bead is touched to the powdered substance to be tested for chlorine; it is now held just within the blue cone of the O. F.; if chlorine is present, an azure-blue copper chloride flame will appear.

b. Wet test. — The substance to be tested is dissolved in nitric acid, if insoluble it is fused with soda and boiled in water; to the clear solution a drop or two of a silver nitrate solution is added, when if chlorine is present, a white precipitate of silver chloride will form, which on exposure to light becomes violet and finally black. Bromine and iodine yield the above reaction also, except the precipitate is yellowish.

c. Separation of chlorine, bromine, and iodine. — The silver precipitate is collected on a filter, and washed with dilute ammonia; silver chloride and silver bromide are dissolved, leaving the silver iodide on the filter, which is tested according to § *d*. The filtrate is made acid with nitric acid; the bromide and chloride of silver filtered and tested for bromine as under bromine, § *c*.

Illustration. — Use halite, NaCl .

Bromine, Br. Atomic weight, 79.92. Fusing point, -7.3°C .

a. Flame test. — Compounds of bromine when treated as in chlorine, § *a*, with copper oxide also yield a blue flame.

b. Bromides are precipitated with silver nitrate as silver bromide, AgBr , a slightly yellowish precipitate soluble in ammonia.

c. If silver bromide is mixed with bismuth sulphide and heated gently in the closed tube, it will yield a sublimate of yellow bismuth bromide directly above the assay. Silver chloride under the same conditions will yield a white sublimate of bismuth chloride.

d. The substance is mixed with potassium bisulphate and fused in a closed tube, when bromine is liberated as reddish yellow vapors, best seen by looking down in the top of the tube.

Illustration. — Use potassium bromide.

Iodine, I. Atomic weight, 126.92. Fusing point, 114.2° C.

a. **Flame test.** — Iodides when heated with copper oxide as in case of chlorine yield a green flame.

b. **Iodides** in solution yield a yellow precipitate of silver iodide, with silver nitrate, nearly insoluble in ammonia, and which does not darken on exposure to light.

c. If the silver iodide from *b* is collected in the bottom of a test tube, a few drops of dilute sulphuric acid, and a fragment of zinc added, the silver will be reduced to metallic silver, and zinc iodide will go in solution. The solution is decanted, a few drops of starch paste (made by boiling starch in water) and fuming nitric acid added. Iodine will be liberated, coloring the starch solution a deep blue.

d. Compounds containing iodine when mixed with bismuth sulphide and heated in the closed tube yield a brick-red sublimate of bismuth iodide.

e. If substances containing iodine are mixed with potassium bisulphate and heated in the closed tube, iodine will be liberated as violet vapors, best seen by looking down in the top of the tube.

Illustration. — Use potassium iodide.

Fluorine, F. Atomic weight, 19. Fusing point, — 223° C.

a. **Closed tube test.** — The ground mineral is mixed with two parts of potassium bisulphate and heated in a closed tube, fluorine is liberated and attacks the walls of the tube, forming a ring, like frosted glass in appearance, due to a deposit of silica, SiO_2 . The hydrofluoric acid liberated by the fusion forms silicon tetrafluoride, SiF_4 , with the silica contained in the glass; this in turn is decomposed with water; thus $3\text{SiF}_4 + 2\text{H}_2\text{O} = 2\text{H}_2\text{SiF}_6 + \text{SiO}_2$. After the frosted ring appears, the bottom of the tube is broken off, and the tube gently dipped in water, then dried carefully; if the ring returns and is non-volatile, it is due to fluorine and is not a sublimate of sulphates. The fusion with potassium bisulphate is not applicable to silicates.

b. Silicates are tested as follows: several S. Ph. beads are made on wire and powdered; 4 parts of this powder are mixed with one part of mineral and fused in the closed tube as directed in *a* above.

Illustration. — Use fluorite, CaF_2 , for *a*, and for *b* use topaz.

Phosphorus, P. Atomic weight, 31.04. Fusing point, 44.2°C .

a. Flame coloration. — Phosphates when heated in fine powder on wire, then moistened with concentrated sulphuric acid, and heated gently until most of the white fumes of SO_2 are driven off, then held at the tip of the blue cone of an O. F., yield a yellowish green flame. The flame appears only momentarily and may be easily overlooked. The charge must be moistened with acid again and heated, when the flame will reappear. Sulphuric acid liberates the phosphoric acid, which volatilizes, coloring the flame.

b. Wet test. — The powdered mineral is dissolved in nitric acid; if not soluble, it is first fused with 4 parts soda, then dissolved. 10 cc. of ammonium molybdate solution are heated in another test tube to boiling, then the nitric acid solution of the mineral is poured into the molybdate, and well shaken. If phosphoric acid is present, a canary-yellow precipitate of ammonium phosphomolybdate, $(\text{NH}_4)_3\text{PO}_4 \cdot 12\text{MoO}_3 \cdot n(\text{H}_2\text{O})$, will form. This yellow precipitate is very soluble in alkalis. Arsenic will yield a similar yellow precipitate, but only upon heating the solution above 80°C .

Illustration. — Use apatite, $\text{Ca}_4\text{CaF}(\text{PO}_4)_3$.

Nitrogen, N. Atomic weight, 14.04. Fusing point, -210°C .

a. Closed tube test. — The powdered mineral is fused in the closed tube with 2 parts of potassium bisulphate, when nitrogen will be liberated as red fumes, NO_2 , best observed by looking down in the open end of the tube.

b. Wet test. — The substance is dissolved in sulphuric acid (one of water to one of acid) and allowed to cool. Holding the tube in a slanting position, a concentrated solution of ferrous sulphate is poured in, so as to form a layer above the solution to be tested, and not mix with it. If nitrates are present, a brown ring will form where the two solutions are slightly mixed on contact.

Illustration. — Use niter, KNO_3 .

Carbon, C. Atomic weight, 12. Infusible.

a. Carbonates. — 3 or 4 cc. of dilute hydrochloric or nitric acid are heated in a test tube and several small fragments of the mineral to be tested are dropped in the hot acid; if carbonates are present, they will be decomposed with effervescence. Minerals are apt to contain a small amount of carbonates as impurities; in such cases the effervescence continues for a short time only; where the mineral is a pure carbonate, effervescence should continue until the mineral has completely dissolved. Carbon dioxide, CO_2 , is

colorless and odorless, which distinguishes it from other gases which may be yielded in dissolving a mineral in acids. A direct test may be applied by holding a glass rod down in the test tube during the effervescence, on the end of which a drop of lime water is suspended. The drop will soon appear milky from the formation of calcium carbonate.

b. Organic carbon. — Carbon in organic matter is detected by heating the substance in a closed tube, when it will blacken, and generally yields an empyreumatic odor, also sometimes an oily distillate.

c. Free carbon, as coal or graphite, when heated on platinum foil, glows, or burns, leaving an ash which is light in color. Diamond must be powdered and heated to a high temperature before it burns.

Illustration. — For *a* use calcite, CaCO_3 , and for *b* any organic acid, as oxalic, $\text{C}_2\text{H}_2\text{O}_4$, will do.

Silicon, Si. Atomic weight, 28.4. Fusing point, 1200°C .

a. Silica, SiO_2 , when heated in the S. Ph. bead, dissolves only very slowly; it yields therefore a translucent bead. If a fragment of a silicate is heated in an S. Ph. bead, the bases or other oxides go into solution, leaving the silica insoluble, in more or less of the same shape as the fragment used. This is known as the silica skeleton.

Illustration. — Use a small fragment of orthoclase, KAlSi_3O_8 .

b. Gelatinization. — Numerous silicates when in fine powder are decomposed by hydrochloric or nitric acid, and on evaporating the solution nearly to dryness the silicic acid will separate and appear as a jelly. Best observed by stirring with a platinum wire; upon further evaporation to dryness the silicic acid is dehydrated. If the dry residue is now moistened with a few drops of dilute HCl , other elements are dissolved as chlorides, leaving the silica as a white insoluble residue, which is filtered out, washed, and tested as in *a*.

Illustration. — Use calamine, $\text{Zn}_2\text{SiO}_4 \cdot 2\text{H}_2\text{O}$.

c. All silicates, when fused with 5 parts soda and dissolved in dilute hydrochloric acid and evaporated as in *b*, yield gelatinous silica; on evaporation to dryness the silica is separated and tested as in *a*. This is the method used in qualitative and quantitative analysis to decompose silicates and separate silica from the bases. All bases will be in the filtrate from the silica and may be detected by appropriate tests.

Illustration: — Fuse powdered orthoclase with soda and separate silica as described.

d. Many silicates when treated with acids decompose, leaving a residue of flocculent silica, which on evaporation does not gelatinize.

Boron, B. Atomic weight, 11. Infusible.

a. **Flame coloration.** — Some borates when heated alone in the forceps yield a green flame; all borates when heated with Turner's flux yield a green flame.

b. The green flame may be due to copper or phosphoric acid. When in doubt, the mineral is fused with soda and dissolved in dilute HCl. A piece of turmeric paper is moistened in this solution, and carefully dried, when if boric acid is present the paper will turn reddish brown.

Illustration. — Grind some tourmaline in the mortar, mix with it 3 parts of Turner's flux and a drop of water. With a platinum wire fuse some of this mixture in the side of the Bunsen burner flame. Just after it begins to fuse, the bright green flame of boron will appear. Mix some of the powdered tourmaline with 4 parts soda and fuse several beads of the mixture on wire. These beads are dissolved in 1 cc. of strong HCl; the solution is then diluted with 4 volumes of water. A piece of turmeric paper is moistened with the solution, placed on a clean watch glass, and dried on the water bath. When dry it will be reddish brown.

TABLE I. — COATS ON COAL

COLOR	REMARKS	SUBSTANCE
White . .	At considerable distance from assay ; easily volatile in O. F. ; in R. F. yields a garlic-like odor	Arsenious oxide, As_2O_3
White . .	At considerable distance from assay ; volatile in R. F., tinging the flame yellowish green	Antimonious oxide, Sb_2O_3
White . .	At considerable distance from assay ; volatile in R. F., tinging the flame an intense green	Thallium oxide, Tl_2O rare,
White . .	Volatile in either flame, coloring the flame green	Tellurous oxide, TeO_2
White . .	Silvery luster, very volatile ; the outer edge may be reddish ; imparts an azure blue color to the flame	Selenious oxide, SeO_2
White . .	Due to chlorides, sulphates of lead bismuth, zinc, mercury, etc. They are identified by other tests	
Yellow, while hot ; white, cold	Volatile in R. F., quickly becoming blue ; in O. F. volatile, leaving a copperlike film on the coal	Molybdenum tri- oxide, MoO_3
Yellow, while hot ; white, cold	Very near the assay, not volatile in O. F., but slowly in R. F. ; treated with cobalt solution, blue-green	Tin oxide, SnO_2
Yellow, while hot ; white, cold	Very near the assay, not volatile in O. F., but slowly in R. F. ; treated with cobalt solution becomes green	Zinc oxide, ZnO
Yellow . .	May have an outer edge of white, volatile ; the substance treated with von Kobell's flux yields a lemon-yellow coat	Lead oxide, PbO
Yellow . .	May have an outer edge of white, volatile ; the substance treated with von Kobell's flux yields a brick-red coat	Bismuth oxide, Bi_2O_3
Brown to yellow . .	Yellow border and iridescent where thin ; volatile	Cadmium oxide, CdO
Red . . .	Generally preceded by a yellow or white coat	Silver with lead or bismuth

TABLE II.—COLOR REACTIONS OF OXIDES IN THE BORAX AND S.Ph. BEADS

BORAX		ELEMENT	S. Ph.	
O. F.	R. F.		O. F.	R. F.
Hot, red to yellow; cold, yellow to colorless	Bottle-green	Iron	Yellow to colorless	Smoky-brown
Hot, yellow; cold, nearly colorless	Brown	Molybdenum	Yellowish green to colorless	Fine green
Hot, orange-red to yellow; cold, yellow to colorless	Bottle-green	Uranium	Greenish-yellow to colorless	Fine green
Hot, yellow; cold, yellow to colorless	Fine green	Vanadium	Yellow to colorless	Green
Hot, yellow; cold, yellowish green	Fine green	Chromium	Green	Green
Hot, pale yellow; cold, colorless	Yellow to brown	Titanium	Colorless	Hot, yellow; cold, violet
Hot, pale yellow; cold, colorless	Yellow to brown	Tungsten	Yellow to colorless	Hot, dirty blue; cold, blue
Hot, orange-yellow; cold, yellow	Colorless	Cerium	Hot, yellow; cold, colorless	Colorless
Hot, green; cold, blue	Colorless to opaque red	Copper	Blue	Colorless to opaque red
Hot, violet; cold, reddish brown	Gray	Nickel	Yellow	Yellow
Hot, violet; cold, reddish violet	Colorless	Manganese	Violet	Colorless
Blue	Blue	Cobalt	Blue	Blue

CHAPTER II

TABLE FOR THE DETERMINATION OF THE MORE COMMON MINERALS, BY THE USE OF THEIR PHYSICAL PROPERTIES

THIS table is arranged in two parts. Part I includes those species which have a metallic luster and usually yield a streak dark in color, and the mineral specimens are opaque, even on their thin edges. Those with a bright luster are metallic and those with a dull luster are considered as sub-metallic.

Part II includes all those species which yield a streak, light in color or colorless; they are termed non-metallic.

As the color of metallic minerals is quite characteristic and more or less constant, Part I is further divided into divisions; minerals of nearly the same color and the species are arranged in each of these divisions according to their hardness.

In Part II, the non-metallic minerals (where the color of the specimens may vary widely), the divisions are made according to the color of their streaks, and those yielding streaks of nearly the same color are placed in the same division; and here again the species are arranged in the divisions according to their hardness.

NOTE. — All material used for the tests should be homogeneous and when crystalline the crystals should be used; remembering always that a mineral naturally soft may appear harder than it really is from impurities, as sand or other hard minerals. Hard minerals may often appear soft on the surface from chemical change or weathering. Impurities often effect the color of the streak of non-metallic minerals, yielding streaks darker than normal.

The abbreviations used are, H. = hardness, C. = color, G. = specific gravity, xls = crystals; cleavage parallel to a crystal form is indicated by the letter representing that form, as cleavage **m** = cleavage parallel to the unit prism; cleavage **r** = parallel to the rhombohedron, etc.

The common colors are placed first; as, white, yellowish, or green would indicate that the mineral is usually white, but yellowish specimens occur which are more common than the green. The same principle applies to the order of other descriptive terms used.

PART I. MINERALS WITH METALLIC OR SUB-METALLIC LUSTER
DIVISION A. COLOR OF SPECIMEN, BLACK OR NEARLY SO

PAGE	SPECIES	HARDNESS	SPEAK	GRAVITY	CLEAVAGE	SYSTEM	REMARKS
284	Graphite	1-2.5	Black	2-2.25	Basal	III	Laminated, compact, scaly, earthy; feels greasy.
296	Molybdenite	1-1.5	Lead-gray	4.7-4.8	Basal	III	Hexagonal plates, scales, massive.
297	Argentite	2-2.5	Gray-black	7-7.5	Not marked	I	Massive, malleable; xls. cubes and octahedrons.
325	Stephanite	2-2.5	Black	6.2-6.3	Imperfect	IV	Small tabular, xls. massive.
352	Pyrolusite	2-2.3	Black	4.7-4.8	None	Am.	Radiated, fibrous, reniform, massive.
322	Pyrrhotite	2.5	Purple-red	5.7-5.8	r, distinct	III	Massive, compact, or granular; reddish xls.
300	Chalcocite	2.5-3	Black-gray	5.5-5.8	m, imperfect	IV	Massive, granular; tabular xls.
340	Melaconite	3-4	Black	5.8-6.3	Basal	V	Massive, earthy; xls. rare.
324	Tetrahedrite	3-4.5	Black, Brown	4.4-5.5	None	I	Massive, fine granular; xls. tetrahedral.
301	Sphalerite	3.5-4	Brownish	3.9-4	Dodecahedral Perfect	I	Crystalline, granular and massive.
367	Manganite	4	Brown-black	4.2-4.4	b, perfect	IV	Columnar striated xls. and stalactitic.
363	Limonite	5-5.5	Brown	3-4	None	Am.	Massive, radiated, botryoidal, stalactitic, and earthy.
542	Wolframite	5-5.5	Brownish	7.2-7.5	b, perfect	V	Tabular and elongated, xls. massive.
525	Uraninite	5.5	Brownish	9-9.7	None	I	Pitchlike, massive, xls. rare.
376	Chromite	5.5	Brownish	4.3-4.5	None	I	Massive, granular, octahedral xls.
346	Menaccanite	5-6	Brownish	4.5-5	None	III	Massive, granular, xls. tabular and plates.
368	Psilomelane	5-6	Brownish	3.7-4.7	None	Am.	Massive, botryoidal, stalactitic, dendritic.
468	Allanite	5.5-6	Gray	3.5-4.2	a, c, trace	V	Pitchy, xls. tabular and prismatic, massive.
373	Magnetite	5.5-6.5	Black	5.1	Octahedral	I	Xls. octahedrons, massive, granular, magnetic.
343	Hematite	5.5-6.5	Red	4.9-5.3	None	III	Tabular and elongated; xls. compact, massive, and earthy. Red, steel-gray, and black.
375	Franklinite	5.5-6.5	Brownish	5-5.5	o, parting	I	Xls. octahedral, granular, massive, brownish black, sometimes magnetic.
505	Columbite	6	Dark red	5.3-7.3	Distinct	IV	Xls. prismatic, massive, brownish black, resinous.
349	Rutile	6-6.5	Brownish	4.3	m, distinct	II	Xls. prismatic, also hairlike, granular. Reddish brown.
347	Cassiterite	6-7	Brownish	6.8-7.1	a, imperfect	II	Xls. short prismatic, massive, rolled pebbles. C. reddish brown to black.

DIVISION B. MINERALS LEAD-GRAY OR SILVER-WHITE IN COLOR

PAGE	SPECIES	HARDNESS	STREAK	GRAVITY	CLEAVAGE	SYSTEM	REMARKS
296	Molybdenite	1-2.5	Lead-gray	4.7-4.8	Basal	III	Laminated, hexagonal plate, scales, massive. C. bluish lead-gray.
284	Graphite	1-2.5	Black	2-2.25	Basal	III	Laminated, compact, scales, earthy; feels greasy.
295	Stibnite	2	Lead-gray	4.5-4.6	b, perfect	IV	Xls. slender prismatic, striated, massive.
352	Pyrolusite	2-2.5	Black	4.7-4.8	None	Am.	Radiated, fibrous, reniform, massive.
298	Galenite	2.5-2.7	Lead-gray	7.4-7.6	Cubic perfect	I	Xls. cubes and octahedrons, granular, massive, and disseminated.
290	Silver	2.5-3	White	10.1-11	None	I	Malleable, scales, wire, and sheets. C. silver-white, dark by tarnish.
321	Bournonite	2.5-3	Steel-gray	5.8	b, imperfect	IV	Xls. short prismatic, tabular, compact, massive. C. bluish lead-gray.
324	Tetrahedrite	3-4.5	Black	4.5-5.5	None	I	Massive, fine granular. Xls. tetrahedral.
316	Cobaltite	5.5	Gray-black	6-6.3	Cubic	I	Xls. pyritohedral, massive. C. reddish silver-white.
316	Gersdorffite	5.5	Gray-black	5.6-6.2	Cubic	I	Massive. Xls. rare, pyritohedral. C. silver-white, tarnishing dark.
315	Smaltite	5.5-6	Gray-black	6.4-6.6	o, distinct	I	Massive. Xls. pyritohedral. C. tin-white to steel gray.
318	Arsenopyrite	5.5-6	Gray-black	5.9-6.2	Prismatic	IV	Xls. small, massive. C. silver-white, yellowish on exposed surfaces.

MINERALS WITH A METALLIC OR SUB-METALLIC LUSTER

DIVISION C. MINERALS RED OR BROWN IN COLOR

PAGE	SPECIES	HARDNESS	STREAK	GRAVITY	CLEAVAGE	SYSTEM	REMARKS
304	Cinnabar	2-2.5	Scarlet	8-8.2	m, perfect	III	Xls. small, tabular, encrusted, massive. C. bright red.
323	Proustite	2-2.5	Scarlet	5.5-5.6	r, distinct	III	Xls. rhombohedral, massive, compact. Translucent. C. scarlet, darkens on exposure.
288	Copper	2.5-3	Red	8.8-8.9	None	I	Malleable, grains, irregular masses and sheets. Copper-red, tarnishing dark.
310	Bornite	3	Gray-black	4.9-5.4	Trace	I	Granular, massive, xls. rare. C. purple to brownish red.
337	Cuprite	3.5-4	Red	5.8-6	Imperfect	I	Xls. small, octahedral and cubes, massive, granular, earthy.
309	Niocolite	5-5.5	Brownish	7.3-7.6	None	III	Massive. Xls. rare. C. pale copper-red.
343	Hematite	5.5-6.5	Red	4.9-5.3	None	III	Tabular and elongated xls. Compact, massive, earthy. C. red, steel-gray to black.
349	Rutile	6-6.5	Brownish	4.1	m, distinct	II	Xls. prismatic, also hairlike, granular. C. reddish brown.
347	Cassiterite	6.7	Brownish	6.8-7	a, imperfect	II	Xls. short prismatic, massive, rolled pebbles. C. reddish brown.

MINERALS WITH A METALLIC OR SUB-METALLIC LUSTER

DIVISION D. MINERALS YELLOW OR BRONZE IN COLOR

PAGE	SPECIES	HARDNESS	STREAK	GRAVITY	CLEAVAGE	SYSTEM	REMARKS
291	Gold	2.5-3	Yellow	15-19	None	I	Malleable grains, scales and nuggets. C. gold-yellow.
310	Bornite	3	Gray-black	4.9-5.4	Trace	I	Granular, massive, xls. rare. C. purple-red to brownish.
310	Chalcopyrite	2.5-3	Gray	5.5-5.8	m, imperfect	II	Massive. Xls. small, tabular and sphenoidal.
307	Millerite	3-3.5	Greenish black	5.3-5.6	Rhombohedral	III	Xls. slender, hairlike radiate, crusts. C. bronze, yellow.
308	Pyrrhotite	3.5-4	Gray-black	4.5-4.6	Basal	III	Massive, granular, xls. small and rare. C. bronze-yellow.
309	Nickelite	5-5.5	Brownish	7.3-7.6	None	III	Massive. Xls. rare. C. pale copper-red.
313	Pyrite	6-6.5	Brownish black	5	Distinct	I	Xls. pyritohedrons, cubes, and octahedrons. Massive. C. brass-yellow.
317	Marcasite	6-6.5	Gray-black	4.9	m, distinct	IV	Xls. small. Massive, radiated, stalactitic, globular. C. Light brass-yellow.

PART II. MINERALS WITH A NON-METALLIC LUSTER

MINERALS WHICH YIELD A STREAK LIGHT IN COLOR AND TRANSMIT LIGHT ON THE THIN EDGES

DIVISION A. MINERALS HAVING A DECIDED TASTE, HARDNESS NOT ABOVE THREE, STREAK WHITE WHEN PURE

PAGE	SPECIES	HARDNESS	COLOR OF MINERAL	GRAVITY	CLEAVAGE	SYSTEM	REMARKS
535	Mirabilite	1.5-2	White	1.5	a, perfect	V	Transparent to opaque. Efflorescent, crusts.
520	Soda niter	1.5-2	White	2.2-2.3	Rhombohedral	III	Massive, crusts. Taste, cooling.
542	Alunogen	1.5-2	Yellowish	1.6-1.8		V	Translucent, fibrous, silky, massive. Alum taste.
539	Melanterite	2	Green	1.9	Basal	V	Capillary, fibrous, massive. Translucent.
328	Sylvite	2	Red, bluish, yellowish	1.98	Cubic perfect	I	Xls. cubic. Transparent. Massive, vitreous, salty taste.
522	Borax	2-2.5	Vitreous	1.7	a, perfect	V	Xls. often large, prismatic. F. conchoidal. Taste sweetish.
538	Epsomite	2-2.5	White	1.7	b, perfect	IV	Xls. prismatic, massive, fibrous. Transparent, translucent.
401	Trona	2.5-3	Grayish	2.1	a, perfect	V	Transparent to translucent, taste, alkaline.
521	Niter	2	White	2.1	(011) perfect	IV	Translucent, vitreous. Taste, cooling.
327	Halite	2.5	Reddish and yellowish	2.3-2.6	Cubic perfect	I	Xls. cubic. Massive, granular; vitreous.
542	Kalinite	2-2.5	White	1.75		I	Fibrous, massive, crusts. Xls. cubes and octahedrons.

MINERALS WITH A NON-METALLIC LUSTER

DIVISION B. MINERALS YIELDING WHITE OR GRAY STREAKS

PAGE	SPECIES	HARDNESS	COLOR OF MINERAL	GRAVITY	CLEAVAGE	SYSTEM	REMARKS
524	Ulexite	1-1.5	White	1.65		I	Fibrous, silky, like snow in texture.
330	Cerargyrite	1-1.5	White to brown	5.5		I	Scetile, waxlike masses.
500	Talc	1-1.5	White, gray, green	2.7-2.8	Basal	V?	Laminæ scetile, inelastic. Massive, fibrous. Xls. rare.
285	Sulphur	1.5-2.5	Yellow to honey	2.1	c, m, p, perfect	IV	Xls. coarse and fine, crusts. Vitreous.
536	Gypsum	1.5-2	White, various	2.3	b, perfect	V	In separate xls, cleavable masses, fibrous, silky luster; granular.
501	Kaolinite	2-2.5	White, various	2.6	c, perfect	V	Scaly, massive, unctuous, plastic.
503	Chrysocolla	2-4	Blue, green, black	2-2.2	None	Am.	Massive, opal-like, botryoidal. Fracture conchoidal.
489	Muscovite	2-2.5	Brown, gray, green	2.7-3	c, micaceous	V	Laminæ flexible, elastic.
492	Biotite	2-2.5	Black, brown, green	2.7-3.1	Micaceous	V	Laminæ flexible, elastic, scales and tabular xls.
497	Chlorite	2-2.5	Shades of green	2.8-3	Micaceous	V?	Foliated, scales, inelastic.
494	Phlogopite	2.5-3	Shades of brown	2.7-2.8	Micaceous	V	Xls. large, six-sided, also in scales.
362	Bruceite	2.5	White, greenish	2.3-2.4	Basal	III	Foliated, fibrous, massive. Xls. tabular.
495	Lepidolite	2.5-4	Rose-red, various	2.8-2.9	Micaceous	V	Scaly aggregates.
501	Sepiolite	2-2.5	White, gray, yellow	2	None	Am.	Compact, earthy.
333	Cryolite	2.5	White, reddish	2.9-3		V	Massive, icelike. Xls. rare.
498	Serpentine	2.5-5	Green, yellow, white	2.5-2.6	b, imperfect	V	Massive, foliated, fibrous, slaty. Xls. rare.
528	Barite	2.5-3.5	White, yellow, blue	4.3-4.6	c, perf.; m, imp.	IV	Xls. tabular and prismatic, massive, banded, radiated.

DIVISION B. NON-METALLIC MINERALS YIELDING A WHITE OR GRAY STREAK

PAGE	SPECIES	HARDNESS	COLOR OF MINERAL	GRAVITY	CLEAVAGE	SYSTEM	REMARKS
366	Bauxite	3	White, various	2.55	—	Am.	Concretionary, oblitic, granular.
379	Calcite	3	White, various	2.72	Rhombohedral	III	Xls. common, grouped, massive and various.
532	Anglesite	3	White, various	6.1-6.4	c, m, distinct	IV	Xls. tabular, prismatic, massive. L, adamantine.
545	Wulfenite	3	Yellow, orange-red	6.7-7	p, dist.; c, less	II	Xls. square tabular, granular.
396	Cerussite	3-3.5	White, gray	6.5	m, i, distinct	IV	Xline aggregates, granular, massive. L, adamantine.
511	Pyromorphite	3.5-4	Gray, yellow, green	6.5-7	m, trace	III	Xls. striated, botryoidal, granular, massive. L, resinous.
531	Anhydrite	3-3.5	White, blue, red	2.9	a, b, c	IV	Xls. tabular, prismatic, massive, granular.
394	Witherite	3-3.75	White, gray	4.3	b, dist.; m, imp.	IV	Xls. pseudo-hexagonal, massive, disseminated.
388	Siderite	3.5	Brown, gray, yellow	3.8	Rhombohedral	III	Xls. rhombohedral often, curved, granular, massive.
392	Aragonite	3.5-4	White, various	2.9-3	b, distinct	IV	Massive, granular, stalactitic. Xls. pseudo-hexagonal.
395	Strontianite	3.5-4	White, yellow, green	3.7	m, perfect; b, trace	IV	Xls. elongated, acicular, radiated, granular.
386	Dolomite	3.5-4	Yellow, gray, white	2.9	Rhombohedral	III	Xls. rhombohedral, often curved, massive. L, pearly.
390	Rhodochrosite	3.5-4.5	Rose, gray	3.4-3.6	Rhombohedral	III	Xls. rhombohedral, massive, crusts.
385	Magnesite	3.5-4.5	White, gray, brown	3	Rhombohedral	III	Massive, earthy, xls. rare.
518	Wavellite	3.2-4	White, various	2.3	p, b, distinct	IV	Globular aggregates with radiated structure, stalactitic.
301	Sphalerite	3.5-4	Brown, yellow, black	4	Dodecahedral	I	Xls. cleavable masses, granular. L, adamantine, or resinous.
483	Stilbite	3.5-4	White, yellow, brown	2.1	b, perfect	V	Xls. complex sheaf-like, divergent, radiated.

DIVISION B. NON-METALLIC MINERALS YIELDING A WHITE OR GRAY STREAK

PAGE	SPECIES	HARDNESS	COLOR OF MINERAL	GRAVITY	CLEAVAGE	SYSTEM	REMARKS
481	Heulandite	3.5-4	White, gray, red	2.2	b, perfect	V	Xline aggregates. Pearly on cleavage face.
331	Fluorite	4	White, yellow, various	3.1	Octahedral	I	Xls. cubic, massive.
484	Chabazite	4.5	White, reddish	2.1	r, distinct	III	Xls. nearly cubical, massive.
480	Apophyllite	4.5-5	White, various	2.3-2.4	c, perfect	II	Xls. square, short, striated, prisms, massive.
543	Scheelite	4.5-5	Shades of yellow	6	(111) distinct	II	Xls. pyramids or tabular, massive, granular.
508	Apatite	4.5-5	Green, brown, various	3.2	c, imperfect	III	Xls. prismatic or tabular, massive.
472	Calamine	4.5-5	White, yellow- ish	3.5	m, imperfect	IV	Xls. tabular implanted, radiated, stalactitic, crusts.
429	Wollastonite	4.5-5	White, gray, yellow	2.9	a, perf.; c, less	V	Cleavable masses, fibrous. Xls. tabular.
427	Pectolite	5	White, gray	2.6	a, c, perfect	V	Xls. acicular, radiated.
391	Smithsonite	5	White, gray, various	4.4	Rhombohedral	III	Botryoidal, stalactitic, crusts. Xls. rare.
485	Analcite	5-5.5	White, pinkish	2.3	a, trace	I	Xls. tetragonal trisectahedron. Massive.
486	Natrolite	5-5.5	White, yellowish	2.2	m, perf.; b, imp.	IV	Xls. elongated, needlelike square prisms. Radi- ated.
463	Datolite	5-5.5	White, green, various	3	—	V	Xls. stout, granular.
507	Monazite	5-5.5	Red, brown	4.9-5.3	c, perf.; a, dist.	V	In rolled grains, sand, and separate xls.
503	Titanite	5-5.5	Brown, various	3.5	m, distinct	V	Xls. wedge-shaped, massive.
453	Wernerite	5-6	White, gray, reddish	2.7	a, m, distinct	II	Xls. coarse, rough, prismatic, massive.
451	Willemite	5.5	Yellow, various	4.3	c, a, easy	III	Massive. Xls. stout prisms.

DIVISION B. NON-METALLIC MINERALS YIELDING A WHITE OR GRAY STREAK

PAGE	SPECIES	HARDNESS	COLOR OF MINERAL	GRAVITY	CLEAVAGE	SYSTEM	REMARKS
419	Pyroxene	5-6	Green, brown, gray	3.2-3.6	m, 87°	V	Xls. short, stout, sometimes bladelike. Massive, granular.
431	Amphibole	5-6	Brown, green, various	2.9-3.4	m, 124°	V	Xls. elongated, also stout, massive, fibrous.
421	Enstatite	5.5	Brown, various	3.1-3.3	m, easy	IV	Fibrous, silky, massive. Xls. rare.
421	Hypersthene	5-6	Dark brown, black	3.4-3.5	b, m, a, distinct	IV	Crystalline, foliated.
461	Cyanite	5-7.2	Blue, gray, green	3.5-3.6	a, b = 106°	VI	Xls. long, bladed.
430	Rhodonite	5.5-6.5	Red, pink, yellow	3.4-3.7	m, perf.; c, less	VI	Massive, granular. Xls. stout, tabular.
441	Nephelite	5-5.6	White, various	2.5-2.6	m, dist.; c, less	III	Massive, Xls. short hexagonal prisms.
438	Sodalite	5.5-6	Gray, blue, various	2.1-2.3	Dodecahedral	I	Massive, granular. Xls. dodecahedral.
416	Leucite	5.5-6	Gray, brown	3.-6.4	(110) distinct	I	Xls. tetragonal trisoctahedrons, granular.
468	Allanite	5.5-6	Brown, black	3.4-4.2	a, c, trace	V	Pitchlike. Xls. tabular, prismatic, massive.
369	Opal	5.5-6.5	All colors	1.9-2.3	None	Am.	Massive, botryoidal, stalactitic. F. conchoidal.
518	Turquoise	6	Blue, green	2.6-2.8	None	Am.	Reniform, veins, grains. F. conchoidal.
470	Prehnite	6-6.5	Green, yellow, gray	2.9	c, distinct	IV	Globular, botryoidal with xline surfaces. Radiated.
403	Orthoclase	6	White, yellowish, red	2.5-2.6	c, a, b 90°	V	Cleavable, massive, and Xls.
409	Microcline	6	Green, white, red	2.5-2.6	c, a, b 90°	VI	Striations on cleavage face.
411	Albite	6-6.5	White, gray	2.6	c, perf.; b, less	VI	Xls. and cleavage striated; massive, granular.
413	Anorthite	6-6.5	Gray, reddish	2.75	c, perf.; b, less	VI	Xls. tabular, elongated; massive, granular.
416	Labradorite	6	Gray, brown	2.7	c, perf.; b, less	VI	Cleavage surfaces striated, iridescent, massive.

DIVISION B. NON-METALLIC MINERALS YIELDING A WHITE OR GRAY STREAK

PAGE	SPECIES	HARDNESS	COLOR OF MINERAL	GRAVITY	CLEAVAGE	SYSTEM	REMARKS
466	Epidote	6-7	Green, olive, brown	3.2-3.5	c, perf.; a, imp.	V	Xls. elongated striated. Granular, massive.
455	Vesuvianite	6.5	Brown, green, yellow	3.3-3.5	m, indistinct	II	Xls. elongated square prisms; massive, granular.
349	Rutile	6-6.5	Brown, reddish	4.1-4.2	a, imperfect	II	Xls. square prisms, acicular; massive.
347	Cassiterite	6-7	Brown, reddish, black	6.8-7.1	a, imperfect	II	Xls. stout prisms, massive, rolled pebbles.
446	Olivine	6.5-7	Green, various	3.2	b, distinct	IV	Granular, massive, separate, xls. rare.
426	Spodumene	6.5-7	White, yellow, green	3.1-3.2	m, perfect	V	Cleavable masses; xls. prismatic striated.
442	Garnet	6.5-7.5	Various	3.1-4.1	d, indistinct	I	Xls. dodecahedrons, tetragonal trisoctahedrons, massive, granular. F. conchoidal.
352	Quartz	7	White, various	2.65	r, difficult	III	Xls. hexagonal prisms, massive, granular. F. conchoidal.
477	Staurolite	7-7.5	Brown, gray	3.6	d, distinct	IV	Xls. prismatic, flattened or cross-shaped.
473	Tourmaline	7-7.5	Black, various	3-3.2	a, r, difficult	III	Xls. elongated striated prismatic. Triangular section.
456	Zircon	7.5	Brown, yellow	4.6-4.7	m, imperfect	II	Xls. square prisms and grains.
459	Andalusite	7.5	White, various	3.1-3.2	m, distinct	IV	Xls. elongated and stout, nearly square prisms. Massive.
436	Beryl	7.5-8	Green, yellow, white	2.6-2.8	c, imperfect	III	Xls. hexagonal prisms, and columnar.
371	Spinel	8	Brown, various	3.5-4.1	o, imperfect	I	Xls. octahedrons.
458	Topaz	8	White, yellow, wine	3.4-3.6	Basal, perfect	IV	Xls. prismatic massive.
341	Corundum	9	Various	3.9-4.1	m, imperfect	III	Xls. coarse prismatic, massive, granular.

DIVISION C. NON-METALLIC MINERALS YIELDING A YELLOW OR ORANGE STREAK

PAGE	SPECIES	HARDNESS	COLOR OF MINERAL	GRAVITY	CLEAVAGE	SYSTEM	REMARKS
295	Orpiment	1.5-2	Lemon-yellow	3.4-3.5	b, perfect	IV	Xls. small, fibrous, laminated, sectile.
294	Realgar	1.5-2	Orange or red	3.5	b, perf. : c, less	V	Xls. small, resinous, granular, crusts.
285	Sulphur	1.5-2.5	Yellow, honey color	2.1	c, m, p, perf.	IV	Xls. coarse and fine, crusts. L. vitreous.
511	Pyromorphite	3.5-4	Green, yellow, gray	6.5-7	m, trace	III	Xls. striated prisms, granular, massive.
301	Sphalerite	3.5-4	Brown, yellow, black	4	Dodecahedral	I	Xls. and cleavable masses, granular. L. adamantine or resinous.
388	Siderite	3.5	Brown, gray, yellow	3.8	Rhombohedral	III	Xls. rhombohedral, often curved faces. Granular, massive.
339	Zincite	4-4.5	Red, yellow	5.4-5.7	Basal perfect	III	Cleavable, massive, foliated, granular, xls. rare.
363	Limonite	5-5.5	Brown, yellow	3.6-4	—	Am.	Botryoidal, stalactitic, radiated, earthy.

NOTE. The following may, if impure, yield yellowish streaks: kaolinite, cuprite, calamine, smithsonite, cinnabar, bauxite, amphibole, pyroxene, rutile, cassiterite.

DIVISION D. NON-METALLIC MINERALS YIELDING RED OR BROWN STREAKS

PAGE	SPECIES	HARDNESS	COLOR OF MINERAL	GRAVITY	CLEAVAGE	SYSTEM	REMARKS
304	Cinnabar	2-2.5	Cochineal red	8-8.2	m, perfect	III	Granular, massive, Xls. rhombohedral.
323	Proustite	2.5-3	Scarlet, vermillion	5.5-5.6	r, distinct	III	Xls. elongated, massive.
322	Pyargyrite	2.5-3	Black, gray	5.7-5.9	r, distinct	III	Xls. prismatic, granular, massive, disseminated.
337	Cuprite	3.5-4	Red to black	5.8-6	o, imperfect	I	Xls. cubic, octahedrons, hairlike, massive, granular.
301	Sphalerite	3.5-4	Brown, yellow, black	4	Dodecahedral	I	Xls. and cleavable masses. L. adamantine or resinous.
363	Limonite	5-5.5	Brown, yellow	3.4-4	—	Am.	Botryoidal, stalactitic, radiated, crusts, earthy.
368	Psilomelane	5-6	Black, brown	3.7-4.7	—	Am.	Botryoidal, stalactitic, massive.
343	Hematite	5.5-6.5	Red, gray, black	4.9-5.3	None	III	Xls. tabular, elongated, radiated, massive, earthy.
376	Chromite	5.5	Brown to black	4.3-4.5	None	I	Massive, granular, xls. octahedrons.
349	Rutile	6-6.5	Brown, reddish	4.1-4.2	a, imperfect	II	Xls. square prism, acicular, massive.
347	Cassiterite	6.7	Brown, red, black	6.8-7.1	a, imperfect	II	Xls. stout prisms, massive, rolled pebbles.

DIVISION F. NON-METALLIC MINERALS YIELDING A GREEN STREAK

PAGE	SPECIES	HARDNESS	COLOR OF MINERAL	GRAVITY	CLEAVAGE	SYSTEM	REMARKS
497	Chlorite	2-2.5	Shades of green	2.8-3	Micaceous	V	Foliated, scales, inelastic.
503	Chrysocolla	2-4	Blue, green, black	2-2.2	F. conchoidal	Am.	Massive, botryoidal.
498	Serpentine	2.5-5	Green, yellow, gray	2.5-2.6	b, distinct	V	Massive, foliated, fibrous.
500	Garnierite	3-4	Green, yellow- ish	2.4		Am.	Crusts, stalactitic, luster dull.
397	Malachite	3.5-4	Green	3.9-4	c, perf.; b, less	V	Crusts, botryoidal, radiated, fibrous.
525	Uraninite	5.5	Brown, gray, black	6.8-7.1	None	I	Pitchlike, massive. Xls. rare.
431	Amphibole	5-6	Brown, green, gray	2.9-3.4	m, 124°	V	Xls. elongated, also stout. Massive, fibrous.
419	Pyroxene	5-6	Brown, green, gray	2.3-3.6	m, 87°	V	Xls. short, stout, sometimes bladed, massive, granular.

DIVISION E. NON-METALLIC MINERALS YIELDING A BLUE STREAK

PAGE	SPECIES	HARDNESS	COLOR OF MINERAL	GRAVITY	CLEAVAGE	SYSTEM	REMARKS
576	Vivianite	1.5-2	Blue, green, brown	2.5-2.7	b, perfect	V	Globular, radiated, earthy. Xls. flattened.
399	Azurite	3.5-4	Dark to light blue	3.7-3.8	(021) perfect	V	Crusts, botryoidal. Xls. rhombohedral in ap- pearance.
502	Chrysocolla	2-4	Blue, green, black	2-2.2	F. conchoidal	Am.	Massive, botryoidal, opal-like.
438	Lapis Lazuli	5.5	Azure-blue	2.4	Dodecahedral	I	Massive, compact. Xls. rare.

CHAPTER III

TABLE FOR THE DETERMINATION OF THE PRINCIPAL ROCK-FORMING MINERALS IN SECTIONS

I. The mineral is opaque.

Magnetite. Isometric.

In crystalline outlines, rounded grains, or dustlike.

By reflected light, bluish black in color; p. 373.

Chromite: Isometric.

In crystalline outline, or rounded grains.

By reflected light brownish and at times the very thin edges may appear brownish; p. 376.

Ilmenite. Hexagonal.

Tabular, thin plates, or irregular in outline.

By reflected light brownish and on very thin edges brown; p. 346.

Hematite. Hexagonal.

In thin plates, scales, and grains.

The thin edges and scales dark red by transmitted light; p. 343.

Graphite. Hexagonal.

In thin flakes, foliated masses, and grains.

By reflected light, metallic luster or dull black; p. 284.

Pyrite. Isometric.

Crystalline outlines, irregular masses, or rounded grains.

By reflected light yellow, metallic luster; p. 313.

Pyrrhotite. Hexagonal.

Irregular grains and masses.

By reflected light bronze-yellow with a metallic luster; p. 308.

II. Transmits light isotropically.

A. *Index of refraction below that of Canada balsam.*

Fluorite. Isometric: $n = 1.43$.

In irregular masses or rounded grains, rarely showing crystalline outlines, filling cavities or veins; Colorless, violet or purple; Cleavage cracks well developed; Relief marked, from the low refraction; p. 331.

Opal: Amorphous: $n = 1.44$.

In irregular masses, grains, and filling veins, often forming the cementing material in sandstones and shales; Colorless or nearly so; In sections may be mistaken for leucite or sodalite; p. 369.

Glass. Amorphous; $n = 1.49$; Variable.

As the residuum of crystallization, irregular in outline, filling the spaces between the crystals; Colorless, gray, or smoky.

Analcite. Isometric; $n = 1.48$.

Rounded crystalline outlines, cloudy grains, or filling cavities and veins; Cleavage cubic but not well developed; Colorless; Usually a secondary mineral after leucite, sodalite, or nepheline; p. 485.

Sodalite group. Isometric; $n = 1.48-1.50$.

In six- or eight-sided crystalline outlines or rounded grains; Cleavage not well developed, often irregularly cracked and fractured; forming the ground mass between crystals of other species; Usually colorless but often yellow or blue, especially haüynite and noselite; Often filled with dustlike inclusions, arranged in zones or collected at the center or margin; p. 436.

Leucite. Isometric; $n = 1.50$.

In six- or eight-sided crystalline outlines, or rounded grains; Cleavage not well developed, often irregularly fractured; inclusions when present are arranged symmetrically in zones or radiating from the center; Colorless; Relief very low; Large crystals are doubly refracting; Interference color first order gray, showing polysynthetic twinning; p. 415.

B. Index of refraction above that of Canada balsam.

Spinel. Isometric; $n = 1.71-1.76$.

In square or six-sided crystalline outlines or rounded grains; Cleavage not developed; Colorless to opaque, according to the species; Relief very marked and surface very rough; p. 371.

Garnet. Isometric; $n = 1.75-1.85$.

In crystalline outlines, rounded grains or irregular masses; Cleavage not developed; Irregularly fractured and cracked; Relief very marked and surface rough; Colorless, to reddish of various shades, also green, brown, to nearly opaque; p. 442.

III. Transmits light anisotropically.

A. *Uniaxial.*

1. Index of refraction less than that of Canada balsam.
 - a. Double refraction equal to or less than that of quartz; not pleochroic.¹

Nephelite. Hexagonal; $n = 1.54$; $\omega - \epsilon = .005$.
In nearly square or hexagonal outline, irregular masses, and rounded grains; Colorless, gray, greenish, bluish or brown; Cleavage prismatic and basal, though not well developed in sections; Relief very flat; Interference color low first order gray; Optically negative (-); p. 440.

Tridymite; Hexagonal; $n = 1.477$; $\epsilon - \omega = .002$.
In hexagonal plates and scaly aggregates; Colorless and transparent; The surface appears rough from the low refraction; Interference color very low gray of the first order; Optically positive (+); p. 361.

Quartz; Hexagonal; $n = 1.547$; $\epsilon - \omega = .009$.
Irregular grains and angular masses; No cleavage or relief; Interference colors first order gray to yellow; Optically positive (+); p. 352.
2. Index of refraction greater than that of Canada balsam.
 - a. Double refraction less than that of quartz.

Apatite; Hexagonal; $n = 1.635$; $\omega - \epsilon = .004$.
Hexagonal sections, prismatic elongated sections, or rounded grains; Cleavage not developed, elongated sections show transverse parting; Colorless; Not pleochroic; Relief not marked; Interference colors first order gray; Optically negative (-); p. 508.

Vesuvianite; Tetragonal; $n = 1.72$; $\omega - \epsilon = .006$.
In short square prisms, grains, or irregular masses; Cleavage not developed; Colorless, yellow, green, brown, or blue; Relief marked, surface rough; Slightly pleochroic; Interference color first order gray, often anomalously high; Optically negative (-); p. 455.

Corundum; Hexagonal; $n = 1.766$; $\omega - \epsilon = .009$.
Crystalline outlines, elongated parallel to \hat{c} , grains or irregular masses; Rhombohedral parting; Colorless, red, or blue; Pleochroic only in highly colored sections; Relief high; Interference color first order gray to yellow; Optically negative (-); p. 341.

¹ Chlorite, which is pleochroic, may appear uniaxial; p. 352.

b. Double refraction greater than that of quartz.

Scapolite; Tetragonal; $n = 1.55-1.58$; $\omega - \epsilon = .013-.035$.

Fibrous aggregates, rounded grains or rods; Cleavage prismatic; Colorless; Not pleochroic; Interference colors, bright, higher first and lower second orders; Optically negative (-); p. 453.

Calcite; Hexagonal; $n = 3.57$; $\omega - \epsilon = .172$.

Irregular masses and grains, often showing twinning lamellæ; Cleavage well developed, rhombohedral, $74^\circ 55'$; Relief varies greatly with the direction of the section; Colorless or pale; Not pleochroic; Interference colors pale of high orders; Optically (-); p. 379.

Tourmaline; Hexagonal; $n = 1.65$; $\omega - \epsilon = .017-.034$.

Lath-shaped, hexagonal or trigonal outlines, fibrous aggregates or rounded grains; Cleavage none; Color, greenish to dark brown, or pale; Pleochroism very marked, increasing with the depth of color of the section; Relief marked; Interference colors, upper first and lower second orders; Optically negative (-); p. 473.

Zircon; Tetragonal; $n = 1.96$; $\epsilon - \omega = .044-.062$.

In short square prisms or rounded grains; Cleavage not well developed; Nearly always colorless; Relief very marked; Not pleochroic; Interference colors brilliant high order; Optically positive (+); p. 456.

Rutile; Tetragonal; $n = 1.76$; $\epsilon - \omega = .287$.

Short square or long acicular prisms or rounded grains; Cleavage not marked; Colorless, brown, or red; Relief very strong; Not pleochroic; Interference colors brilliant high order, but not recognizable in deeply colored sections; Optically positive (+); p. 349.

Biotite may at times appear uniaxial, see p. 615.

B. Biaxial.

1. Index of refraction less than that of Canada balsam.

a. Double refraction that of quartz or less. Not pleochroic.
Zeolites; $n = 1.48 - 1.53$; Double refraction .003-.012.
In acicular or fibrous aggregates filling cavities or veins.

Color, white; Interference colors first order gray to yellow; p. 478.

Orthoclase; Monoclinic; $n = 1.52$; $\gamma - \alpha = .006$.

Plates and lath-shaped crystalline outlines, grains, and irregular masses; Cleavages, 001 and 010 well developed; Relief low, surface smooth; Colorless, transparent or cloudy through decomposition; Carlsbad twinning common; Interference colors low grays of the first order; Optically negative (-); p. 403.

Microcline; Triclinic; $n = 1.53$; $\gamma - \alpha = .007$.

Like orthoclase but twinning very common, showing the characteristic gridiron structure; Optically negative (-); p. 409.

Leucite; Large crystals will appear doubly refracting, see p. 610. Colorless amphiboles and andalusite may not show pleochroism. See p. 416.

Kaolinite; Monoclinic; $n = 1.54$; $\gamma - \alpha = .008$.

White scales, leafy or fibrous aggregates; Relief very low; Interference colors gray first order; a secondary or decomposition product; Optically (-); p. 501.

Iolite; Orthorhombic; $n = 1.54$; $\gamma - \alpha = .009$.

Short prisms, grains, and irregular masses; Cleavage not developed; Colorless; Relief very flat, much like quartz; Pleochroism not marked in thin sections, except in the surrounding halos; Interference colors first order grays to yellow; Optically negative (-); p. 440.

Enstatite; Orthorhombic; $n = 1.66$; $\gamma - \alpha = .009$.

Crystalline outlines, prismatic, fibrous, or in rounded grains; Inclusions often symmetrically arranged; Cleavage prismatic at 92° ; Interference colors high first order about the same as quartz; Optically (+); p. 421.

b. Double refraction greater than that of quartz.

Zeolites; some of the zeolites possess a double refraction as high as .012; p. 612.

Gypsum; Monoclinic; $n = 1.524$; $\gamma - \alpha = .010$.

Granular, tablets, and fibrous aggregates; Cleavage well developed with abundant cracks and often twinned; Colorless; Interference colors first order yellow to orange; Optically positive (+); p. 536.

Albite; triclinic; $n = 1.533$; $\gamma - \alpha = .010$.

Plates, grains, lath-shaped or irregular; Twinning lamellæ very common; Extinction inclined; Cleavage, 001 and 010, usually well developed; Relief very flat; Interference colors first order gray to yellow; Optically positive (+); p. 411.

Serpentine; Orthorhombic; $n = 1.54$; $\gamma - \alpha = .013$. Scales or fibrous aggregates; A secondary product; Surface smooth; Colorless to green; Interference colors first order gray to orange; Optically positive (+); p. 498.

2. Index of refraction greater than that of Canada balsam.

a. Not pleochroic.

Plagioclases. Triclinic; $n = 1.53-1.58$; $\gamma - \alpha = .010-.013$.

Plates, grains, lath-shaped or irregular in outline; Polysynthetic twinning lamellæ very common; Relief flat, surface smooth; Colorless, sometimes clouded; Interference colors first order grays to orange; Optically (\pm). For extinction and distinction of the species see p. 411.

Talc; $n = 1.572$; $\gamma - \alpha = .050$.

Scaly or fibrous aggregates; A secondary product; Relief marked, surface slightly rough; Colorless; Interference colors bright second or third orders; Optically negative (-); p. 500.

Muscovite; Monoclinic; $n = 1.587$; $\gamma - \alpha = .038$.

Scales, flakes, or shreds; Cleavage .001 characteristic, and well developed; Tabular sections show no cleavage and have a very low relief, while the elongated sections showing cleavage have a marked relief and nearly parallel extinction; Interference colors bright second order; Axial angle large; Optically negative (-); p. 489.

Sillimanite; Orthorhombic; $n = 1.667$; $\gamma - \alpha = .022$.

Fibrous or needle-like aggregates, often with a transverse parting; Colorless; Relief marked, surface rough; Parallel extinction; Interference color bright upper first or lower second orders; Optically positive (+); p. 461.

Olivine; Orthorhombic; $n = 1.67$; $\gamma - \alpha = .035$.

Short prismatic, grains or irregular in outline; Cleavage 001 and 010 usually well developed; Irregular

fractures common; Relief marked and surfaces rough; Colorless to green or brown; Interference colors bright second or third orders; Parallel extinction; Optically positive (+); p. 446.

Pyroxenes; Monoclinic; $n = 1.68-1.72$; $\gamma - \alpha = .022-.029$.

Prismatic crystals, grains or irregular outlines; Cleavage prismatic, 87° ; Color, shades of green, yellow, or brown; Relief strongly marked; Interference colors bright second order; Extinction from $36^\circ-54^\circ$; Optically positive (+); p. 419.

Cyanite; Triclinic; $n = 1.723$; $\gamma - \alpha = .012$.

In elongated crystals, columnar or tablets; Cleavage distinct, 74° ; Colorless to bluish, when dark in color pleochroic; Interference colors, gray to yellow or red of the first order; Axial angle large; Optically negative (-). p. 461.

b. Pleochroic.

Chlorite; Monoclinic; $n = 1.576$; $\gamma - \alpha = .001-.013$.

Sheets or scaly aggregates; Cleavage basal micaceous; Shades of green; Relief not marked; Pleochroism marked; Interference colors gray or yellow of the first order, anomalously indigo blue; Optically (\pm); p. 497.

Biotite; Monoclinic; $n = 1.58$; $\gamma - \alpha = .085$.

Flakes, plates, or shreds; Micaceous cleavage well developed; Tabular sections show no cleavage and have a very low relief; Extinction nearly parallel; Pleochroism marked; Interference colors bright second order; $2V$ usually nearly zero; Optically (-); p. 492.

Amphiboles; Monoclinic; $n = 1.62-1.64$; $\gamma - \alpha = .016-.072$.

In crystalline outlines, irregular masses, or rounded grains; Cleavage prismatic, $124^\circ 30'$, well developed; Relief marked; Colorless, green or brown; Pleochroism very marked in dark colored sections, much less in colorless sections, absorption being the greatest parallel to the cleavage cracks; Interference colors bright second order to high orders in basaltic varieties; Extinction $9^\circ-20^\circ$; Optically negative (-); p. 431.

Andalusite; Orthorhombic; $n = 1.64$; $\gamma - \alpha = .011$.

Prismatic or square crystalline outlines, or grains; Cleavage prismatic, at times well developed; Colorless, reddish, or spotted; Relief marked; Pleochroism strong in colored specimens; Interference colors first order grays to yellow; Extinction parallel; Axial angle large; Optically negative (-); p. 459.

Hypersthene; Orthorhombic; $n = 1.67$; $\gamma - \alpha = .013$.

Prismatic, fibrous or in grains; Cleavage prismatic, 92° , also parting (010); Color, shades of brown; Relief marked; Inclusions of plates or rods parallel arranged, characteristic; Pleochroism increases with the depth of color; Interference colors gray, yellow, to orange of the first order; Optically negative (-); p. 421.

Staurolite; Orthorhombic; $n = 1.741$; $\gamma - \alpha = .010$.

Short prismatic crystalline outlines; Twins common; Color, shades of yellow or brown; Cleavage prismatic and 010 distinct; Relief marked; Pleochroism changing from reddish to yellow; Large crystals contain many inclusions; Interference colors first order yellow to orange; Parallel extinction; Axial angle large; Optically positive (+); p. 477.

Epidote; Monoclinic; $n = 1.751$; $\gamma - \alpha = .032$.

Crystals elongated parallel to the orthoaxis, or granular; Cleavage basal, well developed; Color, shades of green, brown to colorless; Relief well marked; Extinction parallel in elongated sections, otherwise the angle is small; Pleochroism increases with the depth of color of the specimen; Interference colors third order; Optically negative (-); p. 466.

Titanite; Monoclinic; $n = 1.938$; $\gamma - \alpha = .145$.

In wedge-shaped crystalline outlines or granular; Cleavage prismatic, distinct, seldom parallel to the crystalline outline; Brown, yellow to colorless; Relief very marked; Interference from low orders to very high; Extinction angles not characteristic; Pleochroism increases with the depth of color of the specimen; Optically positive (+); p. 503.

CHAPTER IV

DETERMINATIVE TABLE

PART I

MINERALS WITH METALLIC, OR SUB-METALLIC LUSTER

ALL minerals included in this section yield a streak dark in color, and when finely ground the color of the powder is also dark. If coarse pieces with thin edges are held between the eye and the yellow flame of the burner, they will appear perfectly dark, and the thin edge will transmit no light. In some species one specimen may be of sub-metallic luster, while another specimen may be of a non-metallic luster; such minerals will be found in both Part I and Part II.

A fragment of the mineral is heated on coal in the O. F. and R. F. alternately; it yields a coat.

I. The coat is white, and while being heated the assay yields a garlic-like odor (arsenic). The presence of arsenic may be proven by the tests on p. 585. Minerals on p. 620.

II. The coat is white and when heated in the inner blue cone of the O. F. colors it yellowish green (antimony). The presence of antimony may be proven by the tests on p. 584. Minerals on p. 623.

III. The coat is white and colors the flame bright green (tellurium). The presence of tellurium may be proven by the tests on p. 587. Minerals on p. 625.

ABBREVIATIONS USED IN THE TABLE

I. Crystallization isometric.	F. Fusibility, fuses.
II. Crystallization tetragonal.	G. Specific gravity.
III. Crystallization hexagonal.	H. Hardness.
IV. Crystallization orthorhombic.	O. F. Oxidizing flame.
V. Crystallization monoclinic.	p. Page.
VI. Crystallization triclinic.	R. F. Reducing flame.
Amorph. Amorphous.	Soda. Sodium carbonate.
B. B. Before the blowpipe.	S. Ph. Salt of phosphorus.
C. Color.	Str. Streak.
Cl. Cleavage.	

IV. The coat is white, with a metallic-like luster, and yields a selenium odor, also colors the flame blue. Test p. 587, p. 626.

V. The coat is yellow when cold, at least near the assay, and with von Kobell's flux shows lead or bismuth. Test p. 579, p. 627.

VI. It yields sulphur dioxide when the powder is heated in the O. F. on coal, or it yields a strong sulphur reaction on silver after fusion with soda; p. 629.

VII. Reduced with soda and borax and a little powdered coal, it yields a malleable metal; p. 631.

VIII. The powdered mineral when dissolved in the borax bead shows manganese. Test p. 574. The mineral is infusible; p. 632.

IX. The mineral when powdered and heated in the R. F. on coal becomes magnetic; p. 632.

X. Minerals not included in the preceding groups; p. 634.

PART II

NON-METALLIC MINERALS OR MINERALS WITHOUT METALLIC OR SUB-METALLIC LUSTER

Minerals included here yield a streak and powder light in color, and will usually transmit light, at least on the thin edges.

I. The mineral has a decided taste, soluble, or soluble to a large extent in water. Hardness below 3. No minerals containing copper or arsenic will be found in this section; p. 635.

II. Easily and quickly volatile (if pure) when heated on coal. If the mineral decrepitates, it should be heated in the closed tube, when it volatilizes and yields a sublimate; p. 640.

III. Roasted, and then reduced with soda, borax, and a little coal dust in R. F. on coal, yields a malleable button.

A. The button is copper or contains copper; p. 641.

B. The button is silver; p. 645.

C. The button is tin; p. 646.

D. The button is lead, or the mineral fused with von Kobell's flux shows lead; p. 646.

IV. Fused with soda and borax in the R. F. on coal, it yields an oxide coat. The arsenic coat is included in Section V; p. 649.

V. In R. F. on coal yields an arsenical odor, or the powdered mineral heated with a few fragments of coal in a closed tube yields an arsenic mirror. Test p. 585, p. 651.

VI. The powdered mineral is dissolved in nitric acid, or if insoluble it is fused with soda, then dissolved; the solution treated with ammonium molybdate yields a yellow precipitate (phosphoric acid); p. 653.

VII. The powdered mineral heated on coal in the R. F. becomes magnetic; p. 657.

VIII. After intense ignition in the forceps, it yields an alkaline reaction with turmeric paper. Hardness below 5; p. 660.

IX. Fused with Turner's flux it yields a green flame (boric acid); p. 663.

X. The powdered mineral when dissolved in the borax bead in the O. F. is violet-red when cold (manganese); p. 665.

XI. The mineral is well powdered and fused with borax, dissolved in concentrated HCl, then boiled with tin; the solution is violet in color (titanium); p. 667.

XII. Treated as in XI, but the borax bead is powdered, dissolved in dilute HCl, and zinc added; the solution becomes blue (tungsten); p. 668.

XIII. The mineral in powder is dissolved in S. Ph.

A. The bead is yellow in R. F. when cold; p. 669.

B. The bead is blue in both flames; p. 669.

C. The bead is green in R. F. when cold; p. 669.

XIV. Minerals not included in the preceding groups. They are classified according to their fusibility, their solubility in acids, and their hardness.

A. Fusibility below 5.

1. Hardness below 5.

+. Yields water.

a. Soluble in HCl; p. 670.

b. Gelatinizes in HCl; p. 671.

c. Not attacked by HCl; p. 671.

-. Yields little or no water; p. 672.

2. Hardness above 5.

+. Yields water.

a. Soluble in HCl; p. 672.

b. Gelatinizes in HCl; p. 673.

c. Insoluble in HCl; p. 674.

-. Yields little or no water.

a. Soluble in HCl; p. 674.

- b. Gelatinizes in HCl; p. 674.
 - c. Insoluble in HCl; p. 675.
- B. Fusibility above 5.
 - 1. Hardness below 5.
 - + . Yields water.
 - a. Soluble in HCl; p. 677.
 - b. Gelatinizes in HCl; p. 678.
 - c. Insoluble in HCl; p. 678.
 - . Yields little or no water; p. 679.
 - 2. Hardness above 5.
 - + . Yields water.
 - a. Soluble in HCl; p. 679.
 - b. Gelatinizes in HCl; p. 679.
 - c. Insoluble in HCl; p. 680.
 - . Yields little or no water.
 - a. Soluble in HCl; p. 680.
 - b. Gelatinizes in HCl; p. 680.
 - c. Insoluble in HCl; p. 681.

PART I

MINERALS WITH METALLIC OR SUB-METALLIC LUSTER

- I. The coat is white, and while being heated the assay yields an arsenic odor. The presence of arsenic may be proven by the tests on p. 585.
- A. *When heated on coal, easily volatile without fusion.*
 - NATIVE ARSENIC**, As; C. Tin-white; Str. Gray; Cl. Basal; H. 3.5; G. 5.7; III.
Fuses easily and volatilizes entirely.
 - Allemontite**, As and Sb; C. Tin-white; Str. Gray; Cl. Basal; H. 3.5; G. 6.2; III.
- B. *After heating on coal a non-volatile residue remains.*
 - 1. Roasted and reduced with soda, yields silver; p. 578.
PEARCEITE, Ag_3AsS_6 ; C. Black; Str. Black; H. 3; G. 6.15; F. 1; V.
 - 2. Roasted on coal, then moistened with HCl and heated in the blue cone, yields an azure-blue flame (copper).

- a.* Fused with soda, yields a sulphur reaction on silver.
- + Residue in R. F. is magnetic.
- TENNANTITE**, $(\text{Cu.Fe})_8\text{As}_2\text{S}_7$; C. Blackish gray; Str. Black to dark red; H. 3; G. 4.6; F. 1.5; p. 324.
- Epigenite**, $4\text{Cu}_2\text{S}, 3\text{FeS}, \text{As}_2\text{S}_5$; C. Steel-gray; Str. Black; H. 3.5; IV.
- Residue in R. F. is not magnetic.
- a.* With von Kobell's flux shows lead.
- Langenbachite**, $\text{Pb}(\text{Ag.Cu})\text{AsS}$; C. Steel-gray; Str. Brownish, marks paper; G. 5.85.
- β .* Shows no lead.
- Binnite**, $\text{Cu}_6\text{As}_4\text{S}_9$; $3\text{Cu}_2\text{S}.\text{As}_2\text{S}_3$; C. Iron-black; Str. Black; H. 2.5-3; G. 4.5; I.
- Lautite**, CuAsS ; C. Iron-black; Str. Black; H. 3; G. 4.9.
- b.* Yields no sulphur reaction.
- Domeykite**, Cu_3As ; C. Steel-gray; Str. Gray; H. 3-3.5; G. 7.5; G. 2; Massive.
- Algodonite**, Cu_6As ; C. Steel-gray; Str. Gray; H. 4; G. 7.6; F. 2; Massive.
- Whitneyite**, Cu_9As ; C. and Str. Silver-white; H. 3.5; G. 8.5; F. 2; Massive.
3. Roasted and then oxidized beside borax on coal, as directed in § *a*, p. 574, it yields a strong cobalt reaction.
- a.* Fused with soda, yields a sulphur reaction.
- COBALTITE**, CoAsS ; C. Tin-white; Str. Black; H. 5.5; G. 6-6.2; F. 2-3; p. 316.
- GLAUCODOT**, $(\text{Co.Fe})\text{AsS}$; C. Gray; Str. Black; H. 5; G. 5.95; F. 2-3.
- b.* Yields no sulphur reaction.
- SMALTITE**, CoAs_2 ; C. Tin-white; Str. Black; H. 5.5-6; G. 6.3; F. 2.5; p. 315.
- Safflorite**, CoAs_2 ; C. Tin-white; Str. Black; H. 4.5-5; G. 7; F. 2.5; IV; p. 315.
- Skutterudite**, CoAs_3 ; C. Tin-white; Str. Black; H. 6; G. 6.75; F. 2.5; I; p. 315.
- The nickel minerals and arsenopyrite below may at times contain considerable cobalt.
4. Roasted and treated beside borax as in 3, it yields a strong nickel reaction, with possibly the first three beads colored with cobalt.

- a. Yields a sulphur reaction with soda. Shows antimony; p. 584.
Corynite, $\text{Ni}(\text{As.Sb})\text{S}$; C. Tin-white; Str. Black; H. 4.5; G. 6; F. 2; I.
Wolfachite, $\text{Ni}(\text{As.Sb})\text{S}$; C. Steel-gray; Str. Black; H. 4.5; G. 6.6; F. 2; IV.
- b. Yields a sulphur, but no antimony, reaction.
GERSDORFFITE, NiAsS ; C. Tin-white; Str. Black; H. 5.5; G. 5.8-6; F. 2; I; p. 316.
- c. Yields little or no sulphur reaction with soda.
NICCOLITE, NiAs ; Pale copper red; Str. Brownish; H. 5-5.5; G. 7.5; F. 2; III; p. 309.
Chloanthite, NiAs_2 ; Tin-white; Str. Black; H. 5.5-6; G. 6.9-7.2; F. 2; I; p. 315.
Rammelsbergite, NiAs_2 ; the same as chloanthite only orthorhombic.
5. Roasted and treated as in 3 above, yields an iron reaction.
- a. Yields with soda a sulphur reaction.
ARSENOPYRITE, FeAsS ; Silver-white; Str. Black; H. 5.5-6; G. 6-6.2; F. 2; IV; p. 319.
- b. Yields with soda no sulphur reaction.
Löllingite, FeAs_2 ; Silver-white; Str. Black; H. 5-5.5; G. 7.2-7.3; F. 2; IV.
Leucopyrite, Fe_3As_4 ; Practically the same as löllingite, massive.
6. With von Kobell's flux shows lead.
- Sartorite**, $\text{PbS.As}_2\text{S}_3$; Lead-gray; Str. Dark brown; H. 3; G. 5.4; F. 1; IV.
Dufrenoyite, $2\text{PbS.As}_2\text{S}_3$; Blackish gray; Str. Black; H. 3; G. 5.56; F. 1; IV.
Gütermannite, $3\text{PbS.As}_2\text{S}_3$; Bluish gray; Str. Black; H. 3; G. 5.9; F. 1; V.
Jordanite, $4\text{PbS.As}_2\text{S}_3$; Blackish gray; Str. Black; H. 3; G. 6.4; F. 1; V.
Baumhauerite, $4\text{PbS.3As}_2\text{S}_3$; Lead-gray; Str. Brown; H. 3; G. 5.33; Cl. Per.; V.
7. With von Kobell's flux shows bismuth.
- Alloclasite**, $\text{Co}(\text{As.Bi})\text{S}$; Steel-gray; Str. Black; H. 4.5; G. 6.6; F. 2; IV.
Bismutosmaltite, $\text{Co}(\text{As.Bi})_3$; Tin-white; Str. Black; H. 6; G. 6.92; F. 2?; I.

8. Yields tests for platinum; p. 582.

Sperrylite, $PtAs_2$; Tin-white; Str. Black; H. 6-7; G. 10.6; F. 2; I; p. 287.

II. The coat is white, and colors the inner flame pale yellowish green (antimony). The presence of antimony may be proven by the tests; p. 584.

A. *Easily and completely volatile (when pure) on coal.*

1. Yields with soda a strong sulphur reaction.

STIBNITE, Sb; Tin-white; Str. Gray; H. 2; G. 4.57; F. 1; IV; p. 295.

2. With soda in the closed tube yields mercury, p. 579.

Livingstonite, $HgS \cdot 2Sb_2S_3$; Lead-gray; Str. Gray-black; H. 2; G. 4.8; F. I; IV.

3. Yields with soda no sulphur reaction.

ANTIMONY, Sb; Tin-white; Str. Gray; H. 3-3.5; G. 6.69; F. 1; Cl. Basal; III.

B. *Not entirely volatile on coal.*

1. With soda yields a sulphur reaction.

a. Roasted and moistened with HCl yields a copper chloride flame; p. 581.

+. With von Kobell's flux shows lead.

BOURNONITE, $2PbS \cdot Cu_2S \cdot Sb_2S_3$; Steel-gray; Str. Black; H. 2.5-3; G. 5.8; F. 1; IV; p. 321.

-. With von Kobell's flux shows neither lead nor bismuth.

Stylotypite, $3(Cu_2 \cdot Ag_2 \cdot Fe)S \cdot Sb_2S_3$; Iron-black; H. 3; G. 4.8; F. 1.5; IV.

Famatinite, $3Cu_2S \cdot Sb_2S_3$; Gray; Str. Black; H. 3.5; G. 4.57; F. 1-1.5; IV.

Chalcostilbite, $Cu_2S \cdot Sb_2S_3$; Blackish gray; Str. Black; H. 3.5; C. basal; G. 4.9; F. 1.5; IV.

Some tetrahedrites, p. 324, and polybasites may fall in this group.

b. Do not yield with HCl a copper chloride flame.

+. With von Kobell's flux shows lead.

a. Reduced with soda and cupeled shows silver; § a, p. 578.

Andorite, $2PbS \cdot Ag_2S \cdot 3Sb_2S_3$; Steel-gray; Str. Black; H. 3-3.3; G. 5.33; F. 1; IV.

Brongniardite, $PbS \cdot Ag_2S \cdot Sb_2S_3$; Black; Str. Black; H. 3-3.5; G. 5.95; F. 1; Massive.

- Diaphorite**, $5(\text{Pb.Ag}_2)\text{S.Sb}_2\text{S}_3$; Steel-gray; Str. Black; H. 2.5-3; G. 5.9-6; F. 1; IV.
- Freieslebenite**, $5(\text{Pb.Ag}_2)\text{S.2Sb}_2\text{S}_3$; Steel-gray; Str. Black; H. 2-2.5; G. 6.3; F. 1; V.
- β**. Shows lead, but no silver.
- Zinkenite**, $\text{PbS.Sb}_2\text{S}_3$; Steel-gray; Str. Black; H. 3-3.5; G. 5.35; F. 1; IV; p. 320.
- Plagionite**, $5\text{PbS.4Sb}_2\text{S}_3$; Blackish-gray; Str. Black; H. 2.5; G. 5.4; F. 1; V.
- Warrenite**, $3\text{PbS.2Sb}_2\text{S}_3$; Blackish-gray; Str. Black; F. 1; Capillary.
- JAMESONITE**, $2\text{PbS.Sb}_2\text{S}_3$; Blackish gray; Str. Black; H. 2-3; G. 5.5-6; F. 1; IV; p. 320.
- Semseyite**, $7\text{PbS.3Sb}_2\text{S}_3$; Gray; Str. Black; G. 5.95; F. 1; V, Tabular.
- BOULANGERITE**, $3\text{PbS.Sb}_2\text{S}_3$; Bluish lead-gray; Str. Black; H. 2.5-3; G. 5.88; F. 1; p. 321.
- Meneghinite**, $4\text{PbS.Sb}_2\text{S}_3$; Blackish gray; Str. Black; H. 2.5; C. pinacoidal; G. 6.35; F. 1; IV.
- Geocronite**, $5\text{PbS.Sb}_2\text{S}_3$; Lead-gray; Str. Black; H. 2.5; G. 6.4; F. 1; IV.
- Kilbrickenite**, $6\text{PbS.Sb}_2\text{S}_3?$; Lead-gray; Str. Black; H. ?; G. 6.4; Massive.
- Epiboulangerite**, $3\text{PbS.Sb}_2\text{S}_3$; Blackish gray; Str. Black; H. ?; G. 6.31; F. 1; IV?
- γ**. With von Kobell's flux shows lead; roasted in the O. F., and the infusible residue reduced with soda, yields tin.
- Cylindrite**, $6\text{PbS, 6SnS}_2, \text{Sb}_2\text{S}_3$; Blackish gray; Str. Black; H. 2.5-3; G. 5.42; F. 1.5;
- Franckeite**, $5\text{PbS, 2SnS}_2, \text{Sb}_2\text{S}_3$; Blackish gray; Str. Black; H. 2-2.5; G. 5.55; F. 1; Tabular.
- . With von Kobell's flux shows no lead.
- α**. Reduced with soda yields silver. Shows sulphur when fused with soda.
- PYRARGYRITE**, $3\text{Ag}_3\text{S, Sb}_2\text{S}_3$; Dark red to black; Str. Purplish red; H. 2-2.5; G. 5.8; F. 1; III; p. 322.
- STEPHANITE**, Ag_5SbS_4 ; Iron-black; Str. Black; H. 2-2.5; G. 6.3; F. 1; IV; p. 325.
- POLYBASITE**, $9(\text{Ag.Cu})_2\text{S, Sb}_2\text{S}_3$; Iron-black; Str. Black; H. 2-3; G. 6.2; F. 1; V; p. 326.

Miargyrite, Ag_2S , Sb_2S_3 ; Iron-black; Str. Red-black; H. 2-2.5; G. 5.2; F. 1; V.

Polyargyrite, $12 \text{Ag}_3\text{S}$, Sb_2S_3 ; Black; Str. Black; H. 2.5; G. 6.97; F. 1; V.

β. With von Kobell's flux shows bismuth, § b, p. 580.

Kobellite, $2 \text{PbS} \cdot (\text{Bi} \cdot \text{Sb})_2\text{S}_3$; Blackish gray; Str. Black; H. 2.5-3; G. 6.3; F. 1.

2. Yields silver, but shows no sulphur.

Dyscrasite, Ag_3Sb ; Silver-gray; Str. Gray; H. 3.5-4; G. 9.75; F. 1.5; IV.

3. Yields a magnetic residue after treatment in the R. F.; yields a sulphur reaction with soda, but contains no copper, lead, or silver.

BERTHIERITE, $\text{FeS} \cdot \text{Sb}_2\text{S}_3$; Steel-gray; Str. Black; H. 2-3; G. 4.2; F. 2; p. 320.

4. Well roasted and dissolved in borax, yields a nickel reaction; p. 574.

a. With von Kobell's flux shows bismuth.

Kallilite, $\text{Ni}(\text{Sb} \cdot \text{Bi})\text{S}$; Light bluish gray; Str. Black; G. 7.01; Massive.

Hauchecornite, $\text{Ni}(\text{Bi} \cdot \text{Sb})\text{S}$; Bronze-yellow; Str. Black; H. 5; G. 6.4; II or Massive.

b. Yields no bismuth.

+ Shows sulphur with soda.

Ullmannite, NiSbS ; Silver-gray; Str. Black; Cl. Cubic; H. 5.5; G. 6.5; F. 1.5; I; p. 311.

- Shows no sulphur with soda.

Breithauptite, NiSb ; Copper-red; H. 5.5; G. 7.54; F. 1.5-2; III; p. 309.

III. The coat is white, and colors the inner blue cone of the flame bright green. The presence of tellurium may be proven by the tests in § b, p. 587.

A. With von Kobell's flux shows lead.

Altaite, PbTe ; Tin-white; Str. Gray; Cl. Cubic; H. 3; G. 8.16; F. 1.5; I.

Nagyagite, $\text{Au}_2\text{Pb}_{14}\text{Sb}_3\text{Te}_7\text{S}_{17}?$; Gray; Str. Black; H. 1-1.5; G. 7.02; F. 1.5; IV.

B. With von Kobell's flux shows bismuth.

Tetradymite, Bi_2Te_3 ; Tin-white; Str. Gray; Cl. Basal; H. 1.5-2; G. 7.4; F. 1.5; III.

Grünlingite, $\text{Bi}_4\text{S}_3\text{Te}$; Pale steel-gray; Str. Gray; G. 7.8; F. 1; H. 1.5–2; III.

Tapalpite, $3\text{Ag}_2(\text{S.Te}).\text{Bi}_2(\text{S.Te})_3$; Pale Steel-gray; Str. Gray; G. 7.8; F. 1; Massive.

C. *With von Kobell's flux shows neither lead nor bismuth.*

1. Easily fusible and volatile.

TELLURIUM, Te; Tin-white; Str. Gray; H. 2–2.5; G. 6.15; F. 1; Cl. Prismatic; III.

a. With soda in the closed tube yields mercury.

Coloradoite, HgTe ; Iron-black; Str. Black; H. 3; G. 8.63; F. 1; Massive.

2. Not entirely volatile.

a. Roasted and reduced with soda yields gold and silver; § a, p. 578.

–. With soda in the closed tube yields no mercury.

Petzite, $(\text{Ag.Au})_2\text{Te}$; Iron-black; Str. Gray; H. 2.5–3; G. 8.86; F. 1.5; Massive.

SYLVANITE $(\text{Au.Ag})\text{Te}_2$; Silver-white; Str. Gray; H. 1.5–2; G. 8.10; F. 1; V.

Goldschmidtite, Au_6AgTe_6 ; Silver-white; Str. grayish black; H. 2; G. 8.6; F. 1; V.

Krennerite, $\text{AuTe}_2 + \text{Ag}$; Silver-white; Str. Gray; H. 2.5; G. 8.35; F. 1; IV; Cl. Basal.

CALAVERITE, $\text{AuTe}_2 + \text{Ag}$; Silver-white; Str. Gray; H. 2.5; G. 9.04; F. 1; VI.

+. With soda in a closed tube yields mercury.

Kalgoorlite, $\text{HgAu}_2\text{Ag}_6\text{Te}_6$; Iron-black; G. 8.76; Massive.

b. Reduced with soda yields silver only.

HESSITE, Ag_2Te ; Steel-gray; Str. Gray; H. 2.5–3; G. 8.60; F. 1; I.

c. The mineral well roasted and dissolved in borax.

+. The bead shows copper.

Richardite, Cu_4Te_3 .

–. The bead shows nickel.

Melonite, Ni_2Te_3 ; Reddish white; Str. Gray; Cl. Basal; III.

IV. The coat is white with a metallic-like luster, also yields a selenium odor and colors the flame blue; § b, p. 587.

A. *Completely volatile on coal.*

1. With soda in the closed tube yields mercury.

TIEMANNITE, HgSe ; Blackish gray; Str. Black; H. 2.5; G. 8.2; I.

Orofrite, $\text{Hg}(\text{S.Se})$; Blackish gray; Str. Black; H. 2.5; G. 8.0; Massive.

B. With von Kobell's flux shows lead.

1. Reduced with soda, the button cupeled shows silver.

Naumannite, $(\text{Ag}_2.\text{Pb})\text{Se}$; Iron-black; Str. Black; H. 2.5; G. 8.0; F. 2; Cl. Cubic; I; Massive.

2. Yields no silver.

Clausthalite, PbSe ; Lead-gray; Str. Black; H. 2.5-3; G. 8; Cl. Cubic; F. 2; I.

C. With von Kobell's flux shows bismuth.

Guanajuatite, Bi_2Se_3 ; Bluish gray; Str. Black; H. 2.5-3.5; G. 6.43; F. 1.5; IV.

D. With von Kobell's flux shows neither lead nor bismuth.

1. Roasted, and reduced with soda shows copper and silver.

Eucairite, CuAgSe ; Lead-gray; H. 2.5; G. 7.5; F. 2; I; Massive.

Crookesite, $(\text{Cu.Te.Ag})_2\text{Se}$; Lead-gray; Str. Black; H. 2.5-3; G. 6.9; F. 1; Massive.

2. Yields, when reduced, copper but no silver.

Berzelianite, Cu_2Se ; Silver-white; Str. Shining; H. 2?; G. 6.7; F. 1.5; Massive.

Umangite, Cu_3Se_2 ; Cherry-red; Str. Black; H. 3; G. 5.62; F. 1.5; Massive.

3. Yields silver but no copper.

Agularite, $\text{Ag}_2\text{Se.Ag}_2\text{S}$; Iron-black; Str. Black; H. 2.5; G. 7.6; F. 1; I.

V. The coat is yellow, at least near the assay. With von Kobell's flux shows lead or bismuth.

A. With von Kobell's flux shows only lead.

1. Fused with soda shows sulphur on silver.

GALENA, PbS ; Lead-gray; Str. Grayish black; H. 2.5; G. 7.6; F. 2; Cl. Cubic; I; p. 298.

2. Fused with soda in O. F. shows manganese; § b, p. 574.

Kentrolite, $(\text{Mn}_4.\text{O}_3)\text{Pb}_3(\text{Si.O}_4)_3$; Black; Str. Brown; H. 5-5.5; G. 6.19; F. 2-2.5; IV.

Senaite, $(\text{Fe.Pb})\text{O}_2(\text{Ti.Mn})\text{O}_2$; Black; Str. Brownish; H. 6; G. 4.78; Inf.; III.

3. Roasted in the R. F. becomes magnetic.

Melanotekite, $Pb_3Fe_4Si_3O_{15}$; Brown to black; Yellowish brown; H. 5-5.5; G. 5.86; F. 2.5; IV.

4. Contains lead only.

Lead, Pb; Lead-gray; Str. Lead-gray; H. 1.5; G. 11.37; F. 1; I.

Plattnerite, PbO_2 ; Iron-black; Str. Brown; H. 5-5.5; G. 8.5; F. 1.5; II.

B. With von Kobell's flux shows lead and bismuth.

1. With HCl a strong copper chloride flame.

Aikinite, $3(Pb,Cu_2)S.Bi_2S_3$; Lead-gray; Str. Grayish black; H. 2-2.5; G. 6.7; F. 1-1.5; IV.

2. Reduced with soda and cupeled yields silver; § a, p. 578.

Schirmerite, $3(Ag_2.Pb)S.2Bi_2S_3$; Lead-gray; Str. Grayish black; G. 6.75; Massive.

Schapbachite, $PbS.Ag_2S.Bi_2S_3$; Lead-gray; Str. Grayish black; H. 3.5; G. 6.43.

3. When reduced yields neither copper nor silver.

Galenobismuthite, $PbS.Bi_2S_3$; Lead-gray; Str. Grayish black; H. 3-4; G. 7.00; Columnar.

Chiviatite, $2PbS.3Bi_2S_3$; Lead-gray; Str. Grayish black; G. 6.92; Foliated.

Rezbanyite, $4PbS.5Bi_2S_3$; Lead-gray; Str. Grayish black; H. 2.5-3; G. 6.24; Massive.

Cosalite, $2PbS.Bi_2S_3$; Lead-gray; Str. Grayish black; H. 2.5-3; G. 6.58; F. 1-1.5; IV.

Lillianite, $3PbS.Bi_2S_3$; Steel-gray; Str. Grayish black; G. 6.1; F. 1-1.5; Massive.

Beegerite, $6PbS.Bi_2S_3$; Gray; Str. Grayish black; Cl. Cubic?; G. 7.27; I?.

C. With von Kobell's flux shows bismuth, but no lead.

1. Roasted and moistened with HCl yields a strong copper chloride flame.

Emplectite, $Cu_2S.Bi_2S_3$; Grayish white; Str. Black; H. 2; G. 6.40; F. 1; IV.

Wittichenite, $3Cu_2S.Bi_2S_3$; Grayish white; Str. Black; H. 3.5; G. 6.70; F. 1; IV.

Klaprotholite, $3Cu_2S.2Bi_2S_3$; Steel-gray; Str. Black; H. 2.5; G. 4.60; F. 1; IV.

Cuprobismutite, $3Cu_2S.4Bi_2S_3$; Bluish black; Str. Black; G. 6.49; F. 1; Prismatic.

2. Yields no copper, but reduced with soda and cupelled yields silver; p. 578.

Matildite, $\text{Ag}_2\text{S}\cdot\text{Bi}_2\text{S}_3$; Gray; Str. Gray; H. 2-3?; G. 6.92; Slender prisms.

3. Yields neither copper nor silver.

BISMUTH, Bi; C. and Str. Silver-white; H. 2-2.5; G. 9.8; F. 1; Cl. Basal; III.

BISMUTHINITE, Bi_2S_3 ; Lead-gray; H. 2; G. 6.45; F. 1; IV; p. 296.

- VI. Yields sulphur dioxide when powdered and heated in the O. F. on coal, or fused with soda yields a strong sulphur reaction on silver, some may yield slight gray coats.

- A. *In the closed tube with soda yields mercury.*

CINNABAR, HgS ; Vermilion; Str. Red; H. 1-2.5; G. 8.10; F. 1.5; III; p. 304.

- B. *Well roasted then reduced with soda and borax yields copper buttons.*

1. The roasted powder is magnetic.

CHALCOPYRITE, CuFeS_2 ; Brass-yellow; Str. Greenish; H. 3.5; G. 4.20; F. 2; II; p. 310.

BORNITE, Cu_3FeS_3 ; Purplish bronze; Str. Grayish black; H. 3; G. 5-5.4; F. 2; I; p. 310.

Cubanite, CuFe_2S_4 ; Brass-yellow; Str. Black; H. 4; G. 4.05; F. 2; Cl. Cubic; I.

Stannite, $\text{Cu}_2\text{S}\cdot\text{FeS}\cdot\text{SnS}_2$; Steel-gray; Str. Black; H. 4; G. 4.4; F. 1.5; p. 312.

2. The roasted mineral is not magnetic.

CHALCOCITE, Cu_2S ; Steel-gray; Str. Black; H. 2.5-3; G. 5.7; F. 2-2.5; IV; p. 300.

COVELLITE, CuS ; Blue; Str. Grayish black; H. 1.5-2; G. 4.6; F. 2.5; III; p. 306.

- a. The nitric acid solution shows silver; § b, p. 578.

Stromeyerite, CuAgS ; C. and Str. Dark steel-gray; H. 2.5-3; G. 6.22; F. 1.5; IV.

- b. Shows vanadium, § b, p. 577.

Sulvanite, $3\text{CuS}\cdot\text{V}_2\text{S}_5$; Bronze-yellow; Massive.

- C. *The nitric acid solution shows silver or reduced with soda yields silver buttons; p. 578.*

1. The roasted mineral is magnetic.

Sternbergite, AgFe_2S_3 ; Bronze; Str. Black; H. 1-1.5; G. 4.15; Cl. Basal; F. 1.5; IV.

2. The roasted mineral is not magnetic.
ARGENTITE, Ag_2S ; C. and Str. Blackish gray; H. 2-2.5; G. 7.2; F. 1.5; I; p. 297.
Acanthite, Ag_2S ; Iron-black; H. 2-2.5; G. 7.25; F. 3.5; IV.
3. When roasted on coal it yields a yellow coat, also reacts for germanium, p. 586.
Argyrodite, Ag_8GeS_6 ; Black; Str. Grayish black; H. 2.5-3; G. 6.27; F. 1.5; I.
4. When reduced with soda yields tin buttons, also reacts for Germanium, p. 586.
Canfieldite, $\text{Ag}_8(\text{Sn.Ge})\text{S}_6$; Black; Str. Grayish black; H. 2.5-3; G. 6.27; F. 1.5-2; I.
- D. *With soda and borax in R. F. on coal yields a zinc coat; § b, p. 573.*
SPHALERITE, ZnS ; Brown to Black; Str. Light brown; H. 3.5-4; G. 4.05; F. 5; I; p. 301.
- E. *Yields a green flame when ignited in the forceps.*
MOLYBDENITE, MoS , Lead-gray; Str. Grayish black; H. 1-1.5; G. 4.75; Inf.; III; p. 296.
- F. *The powdered mineral is well roasted, and dissolved in borax on wire.*
1. The borax bead shows iron; § a, p. 575.
- a. Naturally magnetic.
PYRRHOTITE, $[\text{Fe}_n\text{S}_{n+1}]$; Bronze; Str. Black; H. 4; G. 4.65; F. 2.5-3; III; p. 308.
Pentlandite, $(\text{Fe.Ni})\text{S}$; Yellowish brown; Str. Black; H. 3.5-4; G. 5; F. 2; I; p. 308.
Troilite, FeS ; Bronze; Str. Black; H. 4; G. 4.75; F. 2.5; Massive.
- b. Naturally not magnetic.
PYRITE, FeS_2 ; Brass-yellow; Str. Brownish black; H. 6-6.5; G. 5.03; F. 3; I; p. 313.
MARCASITE, FeS_2 ; Pale yellow; Str. Grayish black; H. 6-6.5; G. 4.88; F. 3; IV; p. 317.
2. The borax bead shows nickel; § a, p. 574.
MILLERITE, NiS ; Brass-yellow; Str. Greenish black; H. 4.5; G. 4.8; F. 2; III; p. 307.
Beyrichite, Ni_3S_4 ; Lead-gray; Str. Gray; H. 3-3.5; G. 4.70; F. 2.
Polydymite, Ni_4S_5 ; Steel-gray; Str. Grayish black; H. 4.5; G. 5.65; F. 2; I.

3. The borax bead shows manganese; § *a*, p. 574.

ALABANDITE, MnS ; Iron-black; Str. Olive-green; H. 3.5-4; G. 3.95; F. 3; I; p. 304.

Hauerite, MnS_2 ; Brownish black; Str. Reddish brown; H. 4; G. 3.46; F. 3; I.

4. The borax bead shows cobalt; § *a*, p. 574.

Linnaeite, $(Co.Ni)_3S_4$; Pale steel-gray; Str. Black; H. 5.5; G. 4.9; F. 2; I.

VII. Reduced with soda and borax on coal, it yields a malleable metal. Or it is a malleable metal.

A. The button is copper.

COPPER, Cu ; Copper-red; Str. Copper-red; H. 2.5-3; G. 8.85; F. 3; I; p. 288.

CUPRITE, Cu_2O ; Grayish red; Str. Red; H. 3.5-4; G. 6.00; F. 3; I; p. 337.

MELACONITE, CuO ; Iron-black; Str. Grayish black; H. 3-4; G. 6.02; F. 3; V; p. 340.

Paramelaconite, CuO ; Purplish black; H. 5; G. 5.83; F. 3; IV.

Crednerite, $Cu_3Mn_4O_9$; Iron-black; Str. Black; H. 4.5; G. 5.00; F. 5.5; V.

B. The button is silver or gold, or both.

SILVER, Ag ; Silver-white; Str. Silver-white; H. 2.5-3; G. 10.5; F. 2; I; p. 290.

GOLD, Au ; C. and Str. Gold-yellow; H. 2.5-3; G. 19.3; F. 2.5-3; I; p. 291.

Electron, $Au.Ag$; C. and Str. Yellowish white; H. 2.5-3; G. 13-16; F. 2.5; I.

With soda in the closed tube shows mercury.

Amalgam, $Hg + Ag$; C. and Str. Silver-white; H. 3-3.5; G. 13.7-14; I.

C. The button is tin.

CASSITERITE, SnO_2 ; Brown to black; Str. Brown; H. 7-8; G. 6.95; Inf.; II; p. 347.

D. Not included above.

Iron, Fe ; Steel-gray; Str. Steel-gray; H. 4-5; G. 7.55; I.

Platinum, Pt ; Whitish steel-gray; H. 4-4.5; G. 14-17; F. Dif.; I; p. 287.

Mercury, Hg ; Tin-white; G. 13.6; Liquid; I; p. 293.

Zinc, Zn ; C. and Str. Grayish white; H. 2; G. 7.0; F. 1.5; III.

Tin, Sn; Tin-white; Str. Tin-white; H. 2; G. 7.2; F. 1; IV.

Palladium, Pd; Steel-gray; Str. Gray; H. 4-4.5; G. 11.55; F. Dif.; I.

Iridosmine, Ir, with Pt, Os, Rh; Tin-white; Str. Gray; H. 6-7; G. 19-21; Inf.; III.

Iridium, Ir, with Pt; Tin-white; Str. Gray; H. 6-7; G. 22.7; F. Inf.; I.

Awaruite, FeNi_2 ; Iron-black; Str. Black; H. 5.5-6; G. 8.3; Massive.

Josephinite, Fe_2Ni_5 ; Color, Gray; Str. Steel-gray; H. 5; G. 6.20; F. Inf.; Mass.

VIII. The powdered mineral dissolved in borax on wire yields a manganese reaction, § a, p. 574. The minerals included here are infusible.

A. *In the closed tube yields water.*

MANGANITE, $\text{Mn}_2(\text{OH})_2\text{O}_2$; Iron-black; Str. Dark brown; H. 41; G. 4.3; IV; p. 340.

1. With soda in R. F. on coal yields a zinc oxide coat; § a, p. 573.

Chalcophanite, $(\text{MnZn})\text{Mn}_2\text{O}_5 \cdot \text{H}_2\text{O}$; Bluish black; Str. Dark brown; H. 2.5; G. 4; III.

Pyrochroite may at times be very dark and yield a dark streak, p. 362.

Psilomelane and **pyrolusite** below may contain a little water.

B. *Yields little or no water.*

PYROLUSITE, MnO_2 ; Iron-black; Str. Black; H. 2-2.5; G. 4.75; Pseudomorphs; p. 352.

PSILOMELANE, MnO_2 , with MnO; Iron-black; Str. Brownish; H. 5-6; G. 4.3; Massive; p. 368.

BRAUNITE, MnMnO_3 ; Black; Str. Brownish black; H. 6-6.5; G. 4.8; II.

HAUSMANNITE, Mn_3O_4 ; Black; Str. Brown; H. 5-5.5; G. 4.8; II.

Polianite, MnO_2 ; Steel-gray; Str. Black; H. 6-6.5; G. 5.00; II.

Pyrophanite, MnTiO_3 ; Deep red; Str. Ocher-yellow; H. 5; G. 4.54; Cl. Rhom.; III.

IX. The powdered mineral heated in the R. F. on coal becomes magnetic.

A. *Fusibility below 4.*

1. Gelatinizes with HCl.

ALLANITE, $(\text{Ca.Fe})_2(\text{Al.Ce.Fe})_2(\text{AlOH})(\text{SiO})_4$; Brown to pitch-black; Str. Gray; H. 5.5-6; G. 3.90; F. 2.5; V; p. 468.

ILVAITE, $\text{CaFe}_2(\text{Fe}_2.\text{OH})(\text{SiO}_4)_2$; Iron-black; Str. Black; H. 5.5-6; G. 4.05; IV; p. 472.

2. Do not gelatinize with HCl. Shows tungsten, § b, p. 587.

WOLFRAMITE, $(\text{Fe.Mn})\text{WO}_4$; Black; Str. Black; H. 5.5; G. 7.35; F. 3-3.5; V; p. 542.

Reinite, FeWO_4 ; Blackish brown; Str. Brown; H. 4; G. 6.64; F. 3-3.5; II.

3. Shows titanium; § b, p. 570.

Neptunite, $(\text{Na.K})_2(\text{Fe.Mn})\text{Ti}(\text{SiO}_3)_4$; Black; Str. Brown; H. 5-6; G. 3.23; F. 3-4; V.

B. *Fusibility above 4.*

1. In the closed tube yields water.

LIMONITE, $2(\text{Fe}_2\text{O}_3).3\text{H}_2\text{O}$; Dark brown; Str. Yellow-ocher; H. 5-5.5; G. 3.80; p. 363.

GÖTHITE, $\text{Fe}_2\text{O}_3.\text{H}_2\text{O}$; Brown to black; Str. Yellow-ocher; H. 5-5.5; G. 4.35; p. 363.

TURGITE, $2\text{Fe}_2\text{O}_3.\text{H}_2\text{O}$; Reddish-black; Str. Indian-red; H. 5.5-6; G. 4.14; p. 363.

2. In the closed tube yields no water.

a. Fused in a soda bead on wire in the O. F. with a little niter shows green sodium manganate; § b, p. 574.

FRANKLINITE, $(\text{Fe.Zn.Mn})\text{O}(\text{Fe.Mn})_2\text{O}_3$; Iron-black; Str. Dark brown; H. 6; G. 5.15; I; p. 375.

Jacobsite, $(\text{Mn.Mg})\text{O}(\text{Fe.Mn})_2\text{O}_3$; Black; Str. Brownish; H. 6; G. 4.75; I.

Bixbyite, FeMnO_3 ; Black; Str. Black; H. 6-6.5; G. 4.91; F. 4.5; I.

The powdered mineral fused with soda on coal yields an antimony coat.

Melanostibian, $6(\text{Fe.Mn})\text{O}, \text{Sb}_2\text{O}_3$; Black; Str. Cherry-red; H. 4; G.?; IV?

b. Fused with soda, boiled in 1 cc. strong HCl, and reduced with tin shows titanium; § b, p. 570.

ILMENITE, FeTiO_3 ; Iron-black; Str. Black; H. 6; G. 5.18; III; p. 346.

Pseudobrookite, $\text{Fe}_4(\text{TiO}_4)_3$; Brownish black; Str. Reddish brown; H. 6; G. 4.94; IV.

When fused with soda on coal yields an antimony coat.

Derbylite, $5\text{FeTiO}_3 \cdot \text{FeSb}_2\text{O}_6$; Pitch-black; Str. Brown; H. 5; G. 4.5; IV.

c. The borax bead shows iron only.

MAGNETITE, Fe_3O_4 ; Iron-black; Str. Black; H. 6; G. 5.18; I; p. 373.

HEMATITE, Fe_2O_3 ; Steel-gray to iron-black; Str. Indian-red; H. 5.5–6.5; G. 5.20; III; p. 343.

Magnesoferrite, $\text{MgO}, \text{Fe}_2\text{O}_3$; Iron-black; Str. Black; H. 6–6.5; G. 4.6; I; p. 371.

d. The borax bead is yellow after oxidation with niter, and shows chromium; § b, p. 569.

CHROMITE, $\text{FeO}, \text{Cr}_2\text{O}_3$, Iron-black; Str. Brown; H. 5.5; G. 4.2; I; p. 376.

X. Minerals which are not included in the preceding divisions.

A. *Compare chromite, wolframite, and molybdenite in preceding sections.*

GRAPHITE, C; Iron-black; Str. Black; H. 1–1.5; G. 2.20; Cl. Basal; III; p. 284.

URANINITE, UO_2, UO_3 ; Black; Brownish black; H. 5.5; G. 9.35; I; p. 525.

B. *The HCl solution reduced with tin shows titanium; § b, p. 570.*

RUTILE, TiO_2 ; Brownish black; Str. Yellowish brown; H. 6–6.5; G. 4.22; II; p. 349.

Brookite, TiO_2 ; Brown to black; Str. yellowish; H. 6; G. 3.95; IV; p. 351.

Perovskite, CaTiO_3 ; Brown to black; Str. Grayish; H. 5.5; G. 3.95; I; p. 347.

C. *The HCl solution reduced with zinc shows columbium; § a, p. 570.*

COLUMBITE, $(\text{Fe}, \text{Mn})(\text{Cb}, \text{Ta})_2\text{O}_6$; Black; Str. Dark red to black; H. 6; G. 5.68; IV; p. 505.

Fergusonite, $(\text{Y}, \text{Er}, \text{Ce})(\text{Cb}, \text{Ta})\text{O}_4$; Brownish black; Str. Dark brown; 5.5–6; G. 5.80; IV; p. 506.

Samarskite, $(\text{Fe}, \text{Ca}, \text{UO}_2)_3(\text{Y}, \text{Er}, \text{Ce})_2(\text{Cb}, \text{Ta})_6\text{O}_{21}$; Velvet-black; Str. Reddish brown; H. 5–6; G. 5.70; IV.

Mossite, $\text{Fe}(\text{Cb}, \text{Ta})_2\text{O}_6$; Black; Str. Black; H. 6; G. 6.45; IV.

Æschynite, $4(\text{Ce}, \text{La}, \text{Er})_5(\text{Ti}, \text{Th})\text{Cb}_4\text{O}_{26}$; Black; Str. Gray; H. 5–6; G. 4.93; IV.

Polycrase, $\text{Cb, Ti, Y, Er, Ce, U, Fe, H, O?}$; Black; Str. Grayish brown; H. 6; G. 6.10.

Polymignite, $\text{Cb, Zr, Ti, Ca, Th, Ce, Y, Fe, O?}$; Black; Str. Dark brown; H. 6.5; G. 4.8; IV.

D. Reacts for tantalum; § a, p. 571; only slight reaction if any for columbium.

Tantalite, $\text{FeMnTa}_2\text{O}_6$; Black; Str. Black; H. 6; G. 7.15; IV.

Tapiolite, FeTa_2O_6 ; Black; Str. Black; H. 6; G. 7.43; II.

Hielmite, $\text{Ta, Cb, Sn, U, Y, Ce, Fe, Mn, Ca, H, O?}$; Black; Str. Grayish; H. 5; G. 5.8; IV.

Yttrotantalite, $(\text{Fe.Ca})(\text{Y.Er.Ce})_2(\text{Ta.Cb})_6\text{O}_{15} \cdot 4 \text{H}_2\text{O}$; Brown to black; Str. Gray; H. 5-5.5; G. 5.70; IV.

PART II

NON-METALLIC MINERALS, OR MINERALS WITHOUT METALLIC OR SUB-METALLIC LUSTER

I. Having taste, or those easily soluble, or soluble to a large extent in water. Hardness below 3. No arsenic or copper minerals are placed in this division.

A. *Dissolved in dilute HCl, yields a white precipitate with barium chloride (sulphates).*

1. Heated on coal in the R. F. it becomes magnetic.

a. Heated on wire it yields a strong yellow flame (sodium).

Sideronatriite, $\text{Na}_2(\text{Fe.OH})(\text{SO}_4)_2 \cdot 2 \text{H}_2\text{O}$; Orange to yellow; L. Silky; H. 2-2.5; G. 2.35; F. 2; IV; Fibrous.

Ferronatriite, $\text{Na, Fe}(\text{SO}_4)_3 \cdot 3 \text{H}_2\text{O}$; Pale green; H. 2; G. 2.55; F. 1.5; III; radiated.

b. Heated on wire it yields a violet flame (potassium).

JAROSITE, $\text{K}(\text{Fe} \cdot 2 \text{OH})_3(\text{SO}_4)_2 \cdot 2 \text{H}_2\text{O}$; Yellow to brown; L. Vitreous; H. 2.5-3.5; G. 3.2; F. 4.5; III.

Metavoltaite, $(\text{K}_2 \cdot \text{Na}_2 \cdot \text{Fe})_5 \text{Fe}_2(\text{Fe.OH})_4(\text{SO}_4)_{12} \cdot 16 \text{H}_2\text{O}$; Yellow; H. 2.5; G. 2.53; F. 4.5; III; Scales.

c. Fused with soda and niter in the O. F. shows manganese.

- Dietrichite**, $(\text{Zn.Fe.Mn})\text{Al}(\text{SO}_4)_4 \cdot 22 \text{H}_2\text{O}$; Dirty white to brownish yellow; Silky; Fibrous.
- Ilesite**, $(\text{Mn.Zn.Fe})\text{SO}_4 \cdot 4 \text{H}_2\text{O}$; Green to white; V.
- d. Shows magnesia; § c, p. 567.
- Knoxvillite**, $(\text{Fe.Mg})[(\text{Fe.Cr.Al})\text{OH}]_7(\text{SO}_4)_8 \cdot 5 \text{H}_2\text{O}$; Greenish yellow; IV.
- Botryogen**, $(\text{Mg.Fe})(\text{Fe.OH})(\text{SO}_4)_2 \cdot 7 \text{H}_2\text{O}$; Hyacinth-red; H. 2-2.5; G. 2.09; F. 4.5; V.
- e. Shows aluminium; § b, p. 568.
- Halotrichite**, $\text{FeAl}_2(\text{SO}_4)_4 \cdot 24 \text{H}_2\text{O}$; Yellowish white; Silky; F. 4.5-5.
- Voltaite**, $\text{Fe}_3(\text{Fe.OH})_2(\text{Fe.Al})_4(\text{SO}_4)_{10} \cdot 14 \text{H}_2\text{O}$; Greenish black; Resinous; H. 3; G. 2.79; F. 1.
- f. Contains iron as the only base.
- Reacts for ferrous iron, but not for ferric.¹
- MELANTERITE**, $\text{FeSO}_4 \cdot 7 \text{H}_2\text{O}$; Apple-green; Vitreous; H. 2; G. 1.9; V; p. 539.
- Contains both ferrous and ferric iron.¹
- Roemerite**, $\text{Fe}''\text{Fe}'''_2(\text{SO}_4)_4 \cdot 12 \text{H}_2\text{O}$; Light to dark brown; H. 3-3.5; G. 2.15; F. 4.5; VI.
- Contains ferric iron only.¹
- Coquimbite**, $\text{Fe}_2(\text{SO}_4)_3 \cdot 9 \text{H}_2\text{O}$; White, yellowish; Vitreous; H. 2; G. 2.11; III.
- Quenstedtite**, $\text{Fe}_2(\text{SO}_4)_3 \cdot 10 \text{H}_2\text{O}$; Reddish violet; Vitreous; H. 2.5; G. 2.11; V.
- Ihleite**, $\text{Fe}_2(\text{SO}_4)_3 \cdot 12 \text{H}_2\text{O}$; Orange-yellow; Vitreous; H. ?; G. 1.81; F. 4.5; Botryoidal.
- COPIAPITE**, $\text{Fe}_2(\text{FeOH})_2(\text{SO}_4)_5 \cdot 17 \text{H}_2\text{O}$; Sulphur-yellow; Pearly; H. 2.5; G. 2.10; F. 4.5-5; V.
- Castanite**, $(\text{Fe.OH})\text{SO}_4 \cdot 3\frac{1}{2}\text{H}_2\text{O}$; Chestnut-brown; Vitreous; H. 2.5; G. 2.12; F. 4.5; V.
- Amarantite**, $(\text{Fe.OH})\text{SO}_4 \cdot 3 \text{H}_2\text{O}$; Orange to brownish red; Resinous; H. 2.5; G. 2.28; F. 4.5; VI.
- Utahite**, $3(\text{FeO})_2\text{SO}_4 \cdot 4 \text{H}_2\text{O}$; Orange yellow; Silky; F. 4.5; III; Tabular.
- Fibroferrite**, $(\text{Fe.OH})\text{SO}_4 \cdot 4\frac{1}{2}\text{H}_2\text{O}$; Pale yellow; Silky; H. 2-2.5; G. 1.85; Fibrous.

¹ Ferrous iron is detected by adding potassium ferricyanide to the cold solution, when a Prussian blue precipitate will form; no precipitate is formed in a solution of ferric salts.

To detect ferric iron a drop or two of ammonium sulphocyanate is added to the solution, when if any ferric iron is present, the solution will assume a deep blood-red color.

- Raimondite**, $\text{Fe}_4(\text{OH})_6(\text{SO}_4)_3 \cdot 4 \text{H}_2\text{O}$; Honey to ocheryellow; H. 3-3.5; G. 3.20; III.
- Carphosiderite**, $\text{Fe}_6(\text{OH})_{10}(\text{SO}_4)_4 \cdot 4 \text{H}_2\text{O}$; Straw-yellow; Resinous; H. 4-4.5; G. 2.5; III.
- g. Dissolved in the borax bead shows nickel; § *a*, p. 574.
Morenosite, $\text{NiSO}_4 \cdot 7 \text{H}_2\text{O}$; Apple-green to greenish white, H. 2; G. 2; Amorph.; IV.
- h. Dissolved in the borax bead shows cobalt; § *a*, p. 574.
Bieberite, $\text{CoSO}_4 \cdot 7 \text{H}_2\text{O}$; Flesh to rose-red; Vitreous; G. 1.92; V; Incrusted.
2. When heated in R. F. on coal it does not become magnetic.
- a. Effervesces with HCl.
HANKSITE, $9 \text{Na}_2\text{SO}_4 \cdot 2 \text{Na}_2\text{CO}_3 \cdot \text{KCl}$; Colorless or white; Vitreous; H. 3-3.5; G. 2.55; F. 1.5; III; p. 535.
- b. Yields a strong sodium flame (yellow); through the blue glass shows a potassium flame also; § *a*, p. 563.
 +. With sodium hydroxide shows ammonia; p. 565.
Lecontite, $(\text{Na} \cdot \text{NH}_4 \cdot \text{K})_2\text{SO}_4 \cdot 2 \text{H}_2\text{O}$; White; Vitreous; H. 2-2.5; G. ?; F. 1; IV.
 —. Shows no ammonia.
Aphthitalite, $(\text{K} \cdot \text{Na})_2\text{SO}_4$; Colorless; Vitreous; H. 3-3.5; G. 2.65; F. 1.5; III.
- c. It yields a sodium flame only.
 +. Yields water in the closed tube.
 α. Shows aluminium with cobalt solution; § *a*, p. 568.
Mendozite, $\text{NaAl}(\text{SO}_4)_2 \cdot 12 \text{H}_2\text{O}$; White; Silky-vitreous; H. 3; G. 1.88; F. 1; Massive.
 β. Shows magnesium with cobalt solution; p. 567.
Loewite, $\text{MgSO}_4 \cdot \text{Na}_2\text{SO}_4 \cdot 2\frac{1}{2} \text{H}_2\text{O}$; White, yellow, red; Vitreous; H. 2.5-3; G. 2.38; F. 1.5; II.
Bloedite, $\text{MgSO}_4 \cdot \text{Na}_2\text{SO}_4 \cdot 4 \text{H}_2\text{O}$; Colorless; Vitreous, H. 2.5; G. 2.25; F. 1.5; V.
 γ. Shows nitrates, § *a*, p. 590.
Darapskite, $\text{Na}_2\text{SO}_4 \cdot \text{NaNO}_3 \cdot \text{H}_2\text{O}$; Colorless; Vitreous; H. 2-3; G. 2.20; F. 3; V, Tabular.
 δ. Shows sodium as the base.
MIRABILITE, $\text{Na}_2\text{SO}_4 \cdot 10 \text{H}_2\text{O}$; Colorless; Vitreous; H. 1.5-2; G. 1.48; F. 1.5; V; p. 535.
 —. Yields no water in the closed tube.
 α. With copper oxide shows chlorine; p. 580.

- Sulphohalite**, $3 \text{Na}_2\text{SO}_4 \cdot 2 \text{NaCl}$; Colorless; Vitreous; H. 3.5; G. 2.50; F. 1.5; I.
- β . Shows no chlorine.
- THENARDITE**, Na_2SO_4 ; Colorless to brownish; H. 2-3; G. 2.69; F. 1.5-2; IV; p. 527.
- d. It shows a potassium flame (violet), p. 563.
- α . With cobalt solution shows aluminium, p. 568.
- Kalinite**, $\text{KAl}(\text{SO}_4)_2 \cdot 12 \text{H}_2\text{O}$; Colorless; Vitreous; H. 2-2.5; G. 1.75; F. 1; I; p. 542.
- β . With copper oxide shows chlorine, § a, p. 580.
- KAINITE**, $\text{MgSO}_4 \cdot \text{KCl} \cdot 3 \text{H}_2\text{O}$; Colorless; H. 2.5-3; G. 2.13; F. 1.5-2; V; p. 534.
- γ . With cobalt solution shows magnesia; § a, p. 567.
- Picromerite**, $\text{MgSO}_4 \cdot \text{K}_2\text{SO}_4 \cdot 6 \text{H}_2\text{O}$; White; H. ?; G. 2.15; F. 1.5-2; V; Yields water.
- Langbeinite**, $2 \text{MgSO}_4 \cdot \text{K}_2\text{SO}_4$; Colorless; H. 3-4; G. 2.81; F. 1.5-2; I; Yields no water.
- δ . With sodium hydroxide yields ammonia; p. 565.
- Taylorite**, $\text{K}_5(\text{NH}_4)(\text{SO}_4)_3$; Yellowish white; H. 2; Massive.
- ϵ . Shows calcium; § b, p. 566.
- Syngenite**, $\text{CaK}_2(\text{SO}_4)_2 \cdot \text{H}_2\text{O}$; Colorless; H. 2.5; G. 2.60; F. 1.5-2; V.
- e. With cobalt solution shows aluminium; p. 568.
- Alunogen**, $\text{Al}_2(\text{SO}_4)_3 \cdot 18 \text{H}_2\text{O}$; White; H. 1.5-2; G. 1.70; V; Fibrous.
- Tschermigite**, $\text{NH}_4\text{Al}(\text{SO}_4)_2 \cdot 12 \text{H}_2\text{O}$; White; H. 1-2; G. 1.50; I; Yields NH_3 with NaOH .
- f. With cobalt solution shows magnesium; § a, p. 567.
- +. With sodium hydroxide shows ammonia, p. 565.
- Boussingaultite**, $\text{MgSO}_4 \cdot (\text{NH}_4)_2\text{SO}_4 \cdot 6 \text{H}_2\text{O}$; Colorless; G. 1.7; V.
- . It yields no ammonia.
- EPSOMITE**, $\text{MgSO}_4 \cdot 7 \text{H}_2\text{O}$; White; Vitreous; H. 2-2.5; G. 1.75; F. 1; IV; p. 538.
- Kieserite**, $\text{MgSO}_4 \cdot \text{H}_2\text{O}$; White, gray, yellow; H. 3-3.5; G. 2.56; F. 2-3?; V; p. 539.
- g. Entirely volatile, boiled with NaOH shows ammonia.
- Mascagnite**, $(\text{NH}_4)_2\text{SO}_4$; White; Vitreous; H. 2-2.5; G. 1.77; F. 1; IV.
- h. Dissolved in borax on wire shows manganese; § a, p. 574.

Mallardite, $\text{MnSO}_4 \cdot 7\text{H}_2\text{O}$; Pink to white; V; Fibrous.
Szmikite, $\text{MnSO}_4 \cdot \text{H}_2\text{O}$; White to pink; H. 1.5; G. 3.15; Amorphous.

Apjohnite, $\text{MnAl}_2(\text{SO}_4)_4 \cdot 24\text{H}_2\text{O}$; White to pale rose; Silky; H. 1.5; G. 1.78; V; Fibrous.

i. Fused with soda in the R. F. on coal it yields a zinc coat.

Goslarite, $\text{ZnSO}_4 \cdot 7\text{H}_2\text{O}$; White; Vitreous; H. 2-2.5; G. 2.00; IV; Acicular.

B. *Effervesces in dilute HCl (carbonates).*

1. Yields a strong sodium flame (yellow).

TRONA, $\text{HNa}_3(\text{CO}_3)_2 \cdot 2\text{H}_2\text{O}$; White to gray; Vitreous; H. 2.5-3; G. 2.13; F. 1.5; V; p. 401.

NATRON, $\text{Na}_2\text{CO}_3 \cdot 10\text{H}_2\text{O}$; White to gray; Vitreous; H. 1-1.5; G. 1.44; F. 1; V; p. 400.

Thermonatrite, $\text{Na}_2\text{CO}_3 \cdot \text{H}_2\text{O}$; White, gray to yellow; H. 1-1.5; G. 1.55; F. 1.5; IV.

C. *With copper oxide shows chlorine; § a, p. 588.*

1. Yields a strong sodium flame.

HALITE, NaCl ; White, red, blue; H. 2.5; G. 2.13; F. 1.5; I; p. 327.

2. It yields a strong potassium flame.

SYLVITE, KCl ; White; H. 2; G. 1.98; F. 1.51; p. 328.

With cobalt solution shows magnesium, p. 567.

CARNALLITE, $\text{MgCl}_2 \cdot \text{KCl} \cdot 6\text{H}_2\text{O}$; White to red; H. 1; G. 1.60; F. 1-1.5; IV; p. 335.

3. Yields a calcium flame.

a. Shows magnesium with cobalt solution; § a, p. 567.

Tachydrite, $\text{CaMg}_3\text{Cl}_6 \cdot 12\text{H}_2\text{O}$; Wax- to honey-yellow; H. 2.5; F. 1; III.

b. It contains no magnesium.

Hydrophylite, CaCl_2 ; White; G. 2.2; F. 1.5; I.

D. *Heated in a closed tube with potassium bisulphate it yields orange-colored fumes (nitrates).*

1. It yields a yellow flame (sodium).

SODA NITER, NaNO_3 ; White; Vitreous; H. 1.5-2; G. 2.29; F. 1.; III; p. 520.

2. It yields a violet flame (potassium).

NITER, KNO_3 ; White; Vitreous; H. 2; G. 2.13; F. 1; IV; p. 521.

3. It yields a green flame (barium).
Nitrobarite, $\text{Ba}(\text{NO}_3)_2$; White; Vitreous; H. 2.5;
 G. 3.20; F. 1–1.5; I.
- E. With turmeric paper the HCl solution shows boric acid; § b,
 p. 592.
1. In the closed tube yields water.
BORAX, $\text{Na}_2\text{B}_4\text{O}_7 \cdot 10 \text{H}_2\text{O}$; Vitreous; H. 2–2.5;
 G. 1.72; F. 1–1.5; V; p. 522.
Sassolite $\text{B}(\text{OH})_3$; White; Pearly; H. 1; G. 1.48;
 F. 0.5; VI.
- II. Easily and completely volatile (when pure) in a gentle O. F.
 If the mineral decrepitates, it should be heated in a
 closed tube, when it should volatilize and yield a
 sublimate.
- A. The mineral burns with a blue flame, yielding sulphur dioxide.
SULPHUR, S; Pale yellow; Resinous; H. 1.5–2.5;
 G. 2.07; F. 1; IV; p. 285.
- B. With soda in R. F. on coal it yields an arsenic odor.
1. Fused with soda in R. F. it yields on silver a sulphur re-
 action.
 –. Yields no green flame.
REALGAR, As_2S_3 ; Aurora-red; Resinous; H. 1.5–2;
 G. 3.55; F. 1; V; p. 294.
ORPIMENT, As_2S_3 ; Lemon-yellow; Pearly to resin-
 ous; H. 1.5–2; G. 3.48; F. 1; V; p. 295.
 +. It yields a green flame (thallium).
Lorandite, $\text{Tl}_2\text{S} \cdot \text{As}_2\text{S}_3$; Carmine-red; Adamantine;
 H. 2–2.5; G. 5.53; F. 1; V.
2. It yields no sulphur reaction with soda.
Arsenolite, As_2O_3 ; White; Adamantine; H. 1.5;
 G. 3.70; Volatile; I; p. 346.
Claudetite, As_2O_3 ; White; Pearly; H. 2.5; G. 4.00;
 Volatile; V.
- C. Yields a white coat which colors the inner flame pale yellowish
 green (antimony); p. 584.
1. With soda it yields a sulphur reaction.
KERMESITE, $\text{Sb}_2\text{S}_2\text{O}$; Brownish red to maroon;
 H. 1–1.5; G. 4.60; F. 1; V.
2. Yields no sulphur reaction with soda.
Senarmonite, Sb_2O_3 ; White; Adamantine; H. 2–2.5;
 G. 5.25; F. 1.5; I.

VALENTINITE, Sb_2O_3 ; White; Pearly, adamantine;
H. 2.5-3; G. 5.56; F. 1.5; IV; p. 346.

D. *Fused with soda in the closed tube it yields mercury*; § a, p. 579.

1. Fused with soda it yields a sulphur reaction on silver.

CINNABAR, MgS ; Red, vermilion; Adamantine;
H. 2-2.5; G. 8.10; F. 1.5; III; p. 304.

2. With copper oxide it shows chlorine, § a, p. 588.

Calomel, HgCl ; White; Adamantine; H. 1-2; G.
6.48; Volatile; II.

Eglestonite, $\text{Hg}_3\text{Cl}_2\text{O}$; Yellow to black; H. 2-3;
G. 8.327; I; Darkens on exposure.

Terlinguaite, Hg_2ClO , Sulphur-yellow, dark olive;
H. 2-3; G. 8.725; V.

3. With copper oxide shows no chlorine.

Montroydite, HgO ; Red; Adamantine; H. 1.5.

E. *Reduced with soda on coal, it yields lead buttons.*

Contunnite, PbCl_2 ; White; Adamantine; H. 1-2;
G. 5.8; Volatile; IV.

III. Powdered, roasted, and then reduced with soda and borax
in R. F. on coal, it yields malleable buttons or scales when
washed in the mortar.

A. *The button is copper or contains copper.*

1. Dissolves in hot dilute HCl with effervescence (carbonates).

MALACHITE, $(\text{CuOH})_2\text{CO}_3$, Bright green; Vitreous;
H. 3.5-4; G. 3.96; F. 3; V; p. 397.

AZURITE, $\text{Cu}(\text{Cu.O.H})_2(\text{CO}_3)_2$; Azure-blue; Vitreous;
H. 3.5-4; G. 3.77; F. 3; V; p. 399.

Aurichalcite, $2(\text{Zn.Cu})\text{CO}_3 \cdot 3(\text{Zn.Cu})(\text{OH})_2$; Pale
green to blue; Pearly; H. 2; G. 3.6; F. Dif.; V.

2. The HCl solution yields a white precipitate with barium
chloride (sulphates).

+. Completely soluble in water, when pure.

CHALCANTHITE, $\text{CuSO}_4 \cdot 5\text{H}_2\text{O}$; Azure-blue; Vit-
reous; H. 2.5; G. 2.21; F. 3; VI; p. 540.

Pisanite, $(\text{Fe.Cu})\text{SO}_4 \cdot 7\text{H}_2\text{O}$; Blue; Vitreous; H. 2.5;
F. 3-4; V; Becomes magnetic.

Kröhnkite, $\text{CuNa}_2(\text{SO}_4)_2 \cdot 2\text{H}_2\text{O}$; Azure-blue; H. 2.5;
G. 1.98; F. 1; V; Yellow flame.

Cyanochroite, $\text{CuK}_2(\text{SO}_4)_2 \cdot 6\text{H}_2\text{O}$; blue; Vitreous; V.

Hydrocyanite, CuSO_4 ; Pale green, Brownish yellow;
F. 3; V; Yields no water.

- . Not completely soluble in water.
- a. Alone yields an azure-blue flame.
- Spangolite**, $(\text{Al.Cl})\text{SO}_4 \cdot 6 \text{Cu}(\text{OH})_2 \cdot 3 \text{H}_2\text{O}$; Dark green; Cl. basal; H. 2–3; G. 3.14; F. 3; III.
- Connellite**, $\text{Cu}_{15}(\text{Cl.OH})_4\text{SO}_{16} \cdot 15 \text{H}_2\text{O}$; Blue; H. 3; G. 3.36; F. 2.5; III. Prismatic.
- b. Do not yield an azure-blue flame.
- BROCHANTITE**, $\text{Cu}_4(\text{OH})_6\text{SO}_4$; Deep emerald-green; H. 3.5–4; G. 3.9; F. 3.5; IV; p. 541.
- Stelznerite**, $\text{CuSO}_4 \cdot 2 \text{Cu}(\text{OH})_2$; Green; G. 3.88; IV.
- Langite**, $\text{CuSO}_4 \cdot 3 \text{Cu}(\text{OH})_2 \cdot \text{H}_2\text{O}$; Blue, greenish blue; H. 2.5–3; G. 3.50; F. 3.5; IV.
- Herrengrundite**, $2(\text{Cu.OH})_2\text{SO}_4 \cdot \text{Cu}(\text{OH})_2 \cdot 3 \text{H}_2\text{O}$; Emerald-green; H. 2.5; G. 3.1; F. 3.5.; V.
- Cyanotrichite**, $\text{Cu}_4\text{Al}_2\text{SO}_{10} \cdot 8 \text{H}_2\text{O}$; Clear blue; Pearly; G. 2.7; F. 3; IV.
- Lindackerite**, $(\text{Cu.OH})_4\text{Cu}_2\text{Ni}_3(\text{SO}_4)(\text{AsO}_4)_4 \cdot 5 \text{H}_2\text{O}$; Verdigris- to apple-green; H. 2–2.5; G. 2.25; F. 2–3; IV.
- Dolerophanite**, $(\text{Cu}_2\text{O})\text{SO}_4$; Brown; F. 3; V; Yields little or no water.
- c. With von Kobell's flux shows lead.
- Arzrunite**, $\text{PbSO}_4 \cdot \text{PbO} \cdot 3\text{CuCl}_2 \cdot \text{Cu}(\text{OH})_2 \cdot \text{H}_2\text{O}$; Blue; F. 2; IV.
- Linariite**, $[(\text{Pb.Cu})\text{OH}]_2\text{SO}_4$; Azure-blue; Cl. pinacoidal; H. 2.5; G. 5.45; F. 1.5; V.
- Caledonite**, $[(\text{Pb.Cu})\text{OH}]_2\text{SO}_4$; Bluish green; Cl. basal; H. 2.5–3; G. 6.40; F. 1.5; IV.
3. The powdered mineral heated in the closed tube with a few small fragments of coal yields an arsenic mirror; § b, p. 585.
- a. The powdered mineral in R. F. becomes magnetic.
- Chenevixite**, $\text{Cu}_2(\text{Fe.O})_2(\text{AsO}_4)_2 \cdot 3 \text{H}_2\text{O}$; Dark to olive-green; Dull; H. 4.5; G. 3.94; F. 2.5; Massive.
- b. With soda and borax in R. F. on coal yields a zinc oxide coat.
- Veszelyite**, $7(\text{Cu.Zn})\text{O} \cdot (\text{As.P})_2\text{O}_5 \cdot 9 \text{H}_2\text{O}$; Greenish blue; H. 3.5–4; G. 3.79; VI.
- c. With von Kobell's flux shows bismuth; § b, p. 580.
- Mixite**, $\text{Cu}_2(\text{Cu.OH})_3\text{Bi}(\text{AsO}_4)_5 \cdot 7 \text{H}_2\text{O}$; Pale green; H. 3–4; G. 3.8; F. 2; Capillary.

- d. With von Kobell's flux shows lead; § c, p. 579.
Bayldonite, $(\text{Pb}, \text{Cu})_3(\text{AsO}_4)_2(\text{Pb}, \text{Cu})(\text{OH})_2 \cdot \text{H}_2\text{O}$; Grass-
to black-green; Resinous; H. 4.5; G. 5.35; F. 2-3;
Mammillary.
- e. Fused with soda in R. F. on coal it yields a sulphur re-
action; § b, p. 587.
Lindackerite $(\text{Cu}, \text{OH})_4\text{Cu}_2\text{Ni}_3\text{SO}_4(\text{AsO}_4)_{4.5} \cdot \text{H}_2\text{O}$; Ver-
digris- to apple-green; H. 2-2.5; G. 2-2.5; F. 2-3;
IV.
- f. Yields a reaction for uranium; § b, p. 576.
Zeunerite, $\text{Cu}(\text{UO}_2)_2(\text{AsO}_4)_{2.8} \cdot \text{H}_2\text{O}$; Emerald-green; H.
2-2.5; G. 3.2; F. 2-3; II.
- g. Contains calcium, § b, p. 566.
Conichalcite, $(\text{Cu}, \text{Ca})(\text{Cu}, \text{OH})(\text{As}, \text{P})\text{O}_4 \cdot \frac{1}{4} \text{H}_2\text{O}$; Em-
erald-green; H. 4.5; G. 4.12; F. 2.5; Massive.
Tyrolite, $(\text{Cu}, \text{Ca})(\text{Cu}, \text{OH})_4(\text{AsO}_4)_{2.7} \cdot \text{H}_2\text{O}$; Pale apple-
green; H. 1-1.5; G. 3.05; F. 2.5; IV.
- h. Contains aluminium; § b, p. 568.
Liroconite, $(\text{Cu}, \text{OH})_9\text{Al}_4(\text{OH})_6(\text{AsO}_4)_{5.20} \cdot \text{H}_2\text{O}$; Sky-
blue; H. 2-2.5; G. 2.9; F. 3-3.5; V.
- i. Not included above, contains copper as the base.
Clinoclasite, $(\text{Cu}, \text{OH})_3\text{AsO}_4$; Dark to bluish green;
H. 2.5-3; G. 4.36; F. 2.5; V.
OLIVENITE, $\text{Cu}(\text{Cu}, \text{OH}), \text{AsO}_4$; Blackish olive-green
to brown; H. 3; G. 4.4; F. 2.5; IV; p. 513.
Euchroite, $\text{Cu}(\text{Cu}, \text{OH})\text{AsO}_4 \cdot 3 \text{H}_2\text{O}$; Emerald-green; H.
3.5-4; G. 3.39; F. 2.5; IV.
Chalcophyllite, $(\text{Cu}, \text{OH})_3\text{AsO}_4(\text{Cu}, \text{OH})_{2.3\frac{1}{2}} \cdot \text{H}_2\text{O}$; Grass-
green; Cl. basal; H. 2; G. 2.53; F. 2.5; III.
Erinite, $\text{Cu}(\text{Cu}, \text{OH})_4(\text{AsO}_4)_2$; Emerald-green; Dull;
H. 4.5; G. 4.04; F. 2.5; Mammillary.
Cornwallite, $\text{Cu}(\text{Cu}, \text{OH})_4(\text{AsO}_4)_{2.3} \cdot \text{H}_2\text{O}$; Emerald-
green; H. 4.5; G. 4.16; F. 2.5; Massive.
Leucochalcite, $\text{Cu}(\text{Cu}, \text{OH})\text{AsO}_4 \cdot \text{H}_2\text{O}$; White to pale
green; Silky; F. 2.5; Capillary.
Trichalcite, $\text{Cu}_3(\text{AsO}_4)_{2.5} \cdot \text{H}_2\text{O}$; Verdigris-green; Silky;
H. 2.5; F. 2.5; Radiated and columnar.
4. The powdered mineral dissolved in nitric acid shows phos-
phoric acid with ammonium molybdate; § b, p. 588.
- a. In R. F. it becomes magnetic.
Chalcosiderite, $\text{Cu}(\text{Fe}, \text{Al})_2(\text{FeO})_4(\text{PO}_4)_{4.8} \cdot \text{H}_2\text{O}$; Light

- to dark green; Cl. basal; H. 2.5; G. 3.1; F. 4-4.5; VI.
- b. With von Kobell's flux shows lead, p. 579.
Vauquelinite, $(\text{Pb.Cu})_3(\text{P.O}_4)_2.2(\text{Pb.Cu})\text{CrO}_4$; Green, brown; Resinous; H. 2.5-3; G. 5.95; F. 2?; V.
- c. In S. Ph. shows uranium; § *a*, p. 576.
TORBERNITE, $\text{Cu}(\text{UO}_2)_2(\text{PO}_4)_2.8\text{H}_2\text{O}$; Emerald- to apple-green; Cl. basal; H. 2-2.5; G. 3.50; F. 3; II; p. 519.
- d. Phosphates of copper only.
LIBETHENITE, $\text{Cu}(\text{Cu.OH})\text{PO}_4$; Dark to olive-green; H. 4; G. 3.70; F. 2.5; IV; p. 513.
PSEUDOMALACHITE, $(\text{Cu.OH})_3\text{PO}_4$; Dark to emerald-green; H. 4.5-5; G. 4-4.4; Massive.
Dihydrate, $\text{Cu}(\text{Cu.OH})_4(\text{PO}_4)_2$; Dark emerald-green; H. 4.5-5; G. 4.20; F. 2.5; V or VI?.
Tagilite, $\text{Cu}(\text{Cu.OH})\text{PO}_4.\text{H}_2\text{O}$; Emerald-green; H. 3-4; G. 4.07; F. 2.5; V; Fibrous.
5. Alone yields an azure-blue flame.
 +. With von Kobell's flux shows no lead.
ATACAMITE, $\text{Cu}_2\text{Cl}(\text{OH})_3$; Deep emerald-green; H. 3-3.5; G. 3.75; F. 3-4; IV; p. 334.
Footelite, $8\text{Cu}(\text{OH})_2.\text{CuCl}_2.4\text{H}_2\text{O}$; Deep blue; V.
Nantokite, CuCl ; White; Adamantine; H. 2-2.5; G. 3.93; F. 1.5; I. Yields no water.
 -. With von Kobell's flux shows lead.
Percylite, $\text{PbCuCl}_2(\text{OH})_2$; Indigo-blue; Brilliant; Cl. cubic; H. 3; G. 5.08; F. 1; I.
Cumengite, $\text{PbCuCl}_2(\text{OH})_2$; Indigo-blue; Cl. pyramidal; H. 3; G. 4.71; F. 1; II.
6. Decomposed with HCl, leaving a residue of silica; § *d*, p. 592.
CHRYSOCOLLA, $\text{CuSiO}_3.2\text{H}_2\text{O}$; Green to turquoise-blue; H. 2-4; G. 2.12; F. Difficult; Massive, p. 503.
DIOPTASE, H_2CuSiO_4 ; Emerald-green; Cl. rhombohedral; H. 5; G. 3.35; F. Difficult; III; p. 452.
7. Not included above.
CUPRITE, Cu_2O ; Ruby-red; Adamantine; H. 3.5-4; G. 6.00; F. 3; I; p. 337.
- a. Fused with soda it yields a sulphur reaction.
COVELLITE, CuS ; Indigo-blue; Cl. basal; H. 1.5-2; G. 4.6; F. 2.5; III; p. 306.

b. Heated in a closed tube with potassium bisulphate it yields NO_2 ; § *a*, p. 590.

Gerhardtite, $\text{Cu}_2(\text{OH})\text{O}_3$; Deep emerald-green; Cl. basal; H. 2; G. 3.42; F. 3; IV.

c. Heated as in *b* it yields iodine; § *a*, p. 589.

Marshite, CuI ; Reddish brown; Resinous; F. 1.5; I.

Cuproidargyrite, AgI.CuI ; Sulphur-yellow; H. 2; Massive.

d. It yields a vanadium reaction; § *b*, p. 577.

Volborthite, $(\text{Cu.OH})_3\text{VO}_4.6\text{H}_2\text{O}$; Cl. pinacoidal; H. 3-3.5; G. 3.55; F. 1.5; Tabular.

Calciovolborthite, $(\text{Cu.Ca})(\text{Cu.OH})\text{VO}_4$; Pistachio- to olive-green; H. 3.5; G. 3.86; F. 1.5-2; Tabular.

e. It yields a tungsten reaction; § *b*, p. 587.

Cuprotungstite, CuWO_4 ; Pistachio-green; Cl. pinacoidal; H. 4.5-5; F. 3; Granular.

f. It yields a reaction for selenium; § *a*, p. 587.

Chalcomenite, $\text{CuSeO}_3.2\text{H}_2\text{O}$; Blue; H. 2.5-3; G. 3.76; F. 1.5; V.

B. Treated as in III, it yields silver buttons or it contains silver, but no Cu.

1. Alone in R. F. on coal it yields an arsenical odor.

PROUSTITE, $3\text{Ag}_2\text{S.As}_2\text{S}_3$; Ruby-red; Adamantine; H. 2-2.5; G. 5.55; F. 1; III; p. 323.

Xanthoconite, $3\text{Ag}_2\text{S.As}_2\text{S}_3$; Orange-yellow to brown; Cl. basal; H. 2; G. 5.54; F. 1; V; Tabular.

2. Yields in R. F. on coal an antimony coat.

PYRARGYRITE, $3\text{Ag}_2\text{S.Sb}_2\text{S}_3$; Dark-red to black; H. 2.5; G. 5.85; F. 1; III; p. 322.

Pyrostilpnite, $3\text{Ag}_2\text{S.Sb}_2\text{S}_3$; Hyacinth-red; H. 2; G. 4.20; F. 1; V; Tabular.

3. With copper oxide it shows chlorine.

CERARGYRITE, AgCl ; Gray to colorless; H. 2-3; G. 5.55; F. 1; I; p. 330.

Iodobromite, $\text{Ag}(\text{Cl.Br.I})$; Sulphur-yellow to green; H. 2-3; G. 5.90; F. 1; I.

4. Shows bromine; § *d*, p. 589.

EMBOLITE, $\text{Ag}(\text{Br.Cl})$; Green or yellow; H. 2-3; G. 5.80; F. 1; I; p. 330.

Bromyrite, AgBr ; Green to yellow; H. 2-3; G. 5.90; F. 1; I.

5. Shows iodine; § c, p. 589.
IODYRITE, AgI; Lemon-yellow; Resinous; H. 1.5;
 G. 5.65; F. 1; III; p. 330.
Miersite, AgI; G. 5.64; F. 1; I.
- C. *Treated as in III the button is tin.*
CASSITERITE, SnO₂; Brown to black; H. 6-7;
 G. 6.95; Inf.; II; p. 347.
1. Yields a boric acid flame with Turner's flux; p. 592.
Nordenskiöddine, CaSn(B.O₃)₂; Sulphur-yellow; Cl.
 basal; H. 5.5-6; G. 4.20; Inf.; III.
2. Yields water in the closed tube.
Stokesite, CaSn(SiO₃)₃.H₂O; Colorless; H. 6; G. 3.18;
 IV.
- D. *Treated as in III the button is lead, or with von Kobell's flux
 shows lead; § b, p. 580.*
1. The powdered mineral heated with a few fragments of
 coal in the closed tube yields an arsenic mirror; § b,
 p. 585.
- a. Becomes magnetic in the R. F.
Carminite, Pb₃Fe₁₀(AsO₄)₁₂; Carmine-red; Cl. pris-
 matic; H. 2.5; G. 4.10; IV.
Lossenite, (Fe.OH)₉(As.O₄)₆.PbSO₄.12 H₂O; Yellow
 to brownish red; H. 3-4; F. 2.5; IV.
Beudantite, Fe, Pb, Cu, SO₄, (P.As)O₄?; Olive-green,
 brown to black; Cl. basal; H. 3.5-4.5; G. 4.15;
 F. 3.5; III.
- b. Yields a chlorine reaction; § a, p. 588.
MIMETITE, Pb₄(Pb.Cl)(AsO₄)₃; White, yellow, brown;
 Resinous; H. 3.5; G. 7.12; F. 1.5; III; p. 512.
Ecdemite, Pb₄As₂O₇.2 PbCl₂; Yellow to green; Greasy;
 Cl. basal; H. 2.5-3; G. 7.00; F. 1.5?; IV.
2. Shows antimony, p. 584, and titanium; § b, p. 570.
Mauzeliite, (Ca.Pb.Na₂)₄TiSb₄O₁₆; Brown; H. 6-6.5; I.
3. Fused with soda it yields a sulphur reaction; § b, p. 587.
- a. Effervesces with hot nitric acid (carbonates).
Leadhillite, Pb₂(Pb.OH)₂(CO₃)₂SO₄; White; Pearly;
 Cl. basal; H. 2.5; G. 6.45; F. 1.5; V.
- b. Yields a strong sodium flame (yellow).
Caracolite, Pb(OH)ClNa₂SO₄; White; H. 4.5; Fl.
 5-2; IV.
- c. Becomes magnetic in R. F.

- Plumbojarosite**, $\text{Pb}[\text{Fe}(\text{OH})_2]_6(\text{SO}_4)_4$; a dark brown powder; G. 3.66; III.
- d. Lead sulphates.
- ANGLESITE**, PbSO_4 ; Gray to white; H. 3; G. 6.35; IV; p. 532.
- Lenarkite**, $(\text{Pb}_2\text{O})\text{SO}_4$; Pale yellow or white; Cl. basal; H. 2-2.5; G. 6.40; F. 2; V.
- e. Gelatinizes with HCl.
- Roebblingite**, $5 \text{H}_2\text{CaSiO}_4 \cdot 2 (\text{Pb}, \text{Ca})\text{SO}_4$; White; H. 2.5-3; G. 3.43; F. 3; Granular.
4. Effervesces with hot dilute nitric acid (carbonates).
- a. Yields a chlorine reaction; § a, p. 588.
- Phosgenite**, $(\text{PbCl})_2\text{CO}_3$; White; Adamantine; Cl. basal; H. 3; G. 6.2; F. 1; II.
- b. Yields water in the closed tubes.
- Hydrocerussite**, $\text{Pb}(\text{Pb}, \text{OH})_2(\text{CO}_3)_2$; White; Pearly; H. 1-2; G. 6.14; F. 1-5; III.
- c. Yields no water.
- CERUSSITE**, PbCO_3 ; White; Adamantine; H. 3-3.5; G. 6.55; F. 1.5; IV; p. 396.
- Beresonite**, $2 \text{PbO} \cdot 3 \text{PbCrO}_4 \cdot \text{PbCO}_3$; Dark red; Cl. perfect; G. 6.69.
5. Yields an antimony coat in R. F. on coal.
- a. Yields a chlorine reaction; § a, p. 588.
- Nadorite**, PbClSbO_2 ; Smoky to yellowish brown; Resinous; H. 3.5-4; G. 7.0; F. 1.5; IV.
- Ochrolite**, $\text{Pb}_4\text{Sb}_2\text{O}_7 \cdot \text{PbCl}_2$; Sulphur to grayish yellow; F. 1.5?; IV.
- b. Yields no chlorine. Yields water.
- Bindheimite**, $\text{Sb}_2\text{O}_3 \cdot \text{PbO}$ and H_2O ; Gray, yellow, brown; H. 4; G. 4.68; F. 3-4; Amorphous.
6. The hot nitric acid solution yields a white precipitate with silver nitrate (chlorine); § b, p. 588.
- Cotunnite**, PbCl_2 ; White; H. 2; G. 5.80; F. 1; IV.
- Penfieldite**, $2\text{PbCl}_2 \cdot \text{PbO}$; White; Cl. basal; H. 2.5; F. 1; III.
- Matlockite**, $\text{PbCl}_2 \cdot \text{PbO}$; Pale yellow to white; Cl. basal; H. 2.5-3; G. 7.20; F. 1; II.
- Mendipite**, $\text{PbCl}_2 \cdot 2 \text{PbO}$; Pale yellow to white; Cl. prismatic; H. 2.5; G. 7.10; F. 1; IV.

- Laurionite**, PbCl(OH) ; White; H. 3-3.5; F. 1; IV;
Yields water.
- Nasonite**, $\text{Pb}_4(\text{Pb.Cl})_2\text{Ca}_4(\text{Si}_2\text{O}_7)_3$; White; H. 4; F. 2;
G. 5.42; II?
- In the closed tube yields a sublimate of lead iodide;
§ *d*, p. 589.
- Schwartzbergite**, $\text{Pb(I.Cl)}_2.2\text{PbO}$; Honey- to straw-
yellow; H. 2-2.5; G. 6.2; F. 1; III.
7. The nitric acid solution shows phosphoric acid with ammo-
nium molybdate; p. 590.
- PYROMORPHITE**, $\text{Pb}_4(\text{Pb.Cl})(\text{PO}_4)_3$; White, yellow,
brown, green; H. 3.5-4; G. 6.80; F. 2; III; p. 511.
8. The mineral powdered and dissolved in nitric acid shows
silica; § *b*, p. 591.
- a.* Becomes magnetic in R. F.
- Melanotekite**, $(\text{Fe}_4\text{O}_3)\text{Pb}_3(\text{SiO}_4)_3$; Dark brown to black;
H. 5-5.5; G. 5.85; F. 2; IV.
- Hancockite**, $(\text{Pb.Ca.Mn})_2(\text{Al.Fe.Mn.OH})(\text{Al.Fe.Mn})_2$
 $(\text{Si.O}_4)_3$; Brownish red; H. 6.5-7; G. 4.03; F. 3;
V; Shows Mn with borax.
- b.* With Turner's flux it yields a green flame (boric acid).
- Hyalotekite**, $(\text{Pb.Ca.Ba})_4(\text{F.OH})\text{B}(\text{SiO}_3)_6$; White; H.
5.5; G. 3.80; F. 3?; Massive.
- c.* In the borax bead it shows manganese.
- Kentrolite**, $(\text{Mn}_4\text{O}_3)\text{Pb}_3(\text{SiO}_4)_3$; Black; H. 5.5; G.
6.19; F. 2-2.5; IV.
- Ganomalite**, $\text{Pb}_3\text{Si}_2\text{O}_7(\text{Ca.Mn})_2\text{SiO}_4$; Gray to white;
H. 3; G. 5.74; F. 3?; II.
- d.* Silicate of lead only.
- Barysilite**, $\text{Pb}_3\text{Si}_2\text{O}_7$; White; Pearly; Cl. basal; H. 3;
G. 6.50; F. 2.5; III.
9. Not included above.
- a.* Shows molybdenum; § *a*, p. 586.
- WULFENITE**, PbMoO_4 ; Yellow, orange, red, white;
H. 4.5-5; G. 6.05; F. 2; II; p. 545.
- b.* Shows vanadium; § *b*, p. 577.
- DESCLOIZITE**, Pb(Pb.OH)VO_4 ; Brown, red; Resin-
ous; H. 3.5; G. 6.05; F. 1.5; IV; p. 514.
- Brackenbuschite**, $\text{Pb,Fe,Mn,(VO}_4\text{).H}_2\text{O?}$; Dark-brown;
F. 1.5; V.
- c.* Shows vanadium, § *b*, p. 577, and chlorine.

Vanadinite, $\text{Pb}_3(\text{Pb,Cl})(\text{VO}_4)_3$; Ruby-red, brown, yellow; H. 3; G. 6.83; F. 1.5; III.

d. Shows tungsten; § b, p. 587.

STOLZITE, PbWO_4 ; Green, yellow, brown, red; Resinous; H. 3; G. 8.00; F. 2.5; II; p. 545.

Raspite, PbWO_4 ; Wax-brown; Resinous; Cl. pinacoidal; H. 2.5-3; G. ?; F. 2.5-3; V.

e. Shows chromium; § b, p. 569.

CROCOITE, PbCrO_4 ; Bright red; Adamantine; H. 2.5-3; G. 6.00; F. 1.5; V; p. 533.

Phoenicochroite, $3\text{PbCrO}_4.\text{PbO}$; Red; Resinous; Cl. pinacoidal; H. 3-3.5; G. 5.75; F. 1.5; IV.

f. Lead oxides only.

Plattnerite, PbO_2 ; Brown-black; H. 5-5.5; G. 8.50; F. 1.5; II.

Minium, Pb_3O_4 ; Red; Dull to greasy; H. 2-3; G. 4.60; F. 1.5; Pulverulent.

Massicot, PbO ; Sulphur- to reddish yellow; Dull; H. 2; G. 8-9; F. 1.5; Massive.

IV. Fused with soda and borax in the R. F. on coal, it yields a coat.

A. It yields a zinc oxide coat; § b, p. 573.

1. Yields with soda a sulphur reaction; § b, p. 587.

a. In R. F. becomes magnetic.

Danalite, $(\text{Zn.Fe})_2(\text{Fe}_2.\text{S})\text{Be}_3(\text{SiO}_4)_3$; Flesh-red to gray; H. 5.5-6; G. 3.43; F. 5.

b. Dissolves in HCl, yielding H_2S .

SPHALERITE, ZnS ; White, green, yellow, brown, black; H. 3.5-4; G. 4.10; F. Difficult; I; p. 301.

2. Effervesces with HCl, yielding CO_2 (carbonates).

SMITHSONITE, ZnCO_3 ; White, brown, green, pink; H. 5; G. 4.37; Inf.; III; p. 391.

Hydrozincite, $2\text{ZnCO}_3.3\text{Zn}(\text{OH})_2$; White, gray, yellow; H. 2-2.5; G. 3.69; Compact.

3. Gelatinizes with HCl.

a. Yields little or no water.

WILLEMITE, Zn_2SiO_4 ; White, yellow, green, blue; H. 5.5; G. 4.10; Inf.; III; p. 451.

Hardystonite, $\text{Ca}_2\text{ZnSi}_2\text{O}_7$; White; H. 3-4; F. Difficult; G. 3.39; Yields a calcium flame.

b. Yields water.

CALAMINE, $(\text{Zn.OH})_2\text{SiO}_3$; White, yellow, blue; H. 4.5-5; G. 3.45; IV; p. 472.

Clinohedrite, $\text{H}_2\text{CaZnSiO}_5$; Amethystine to white; H. 5-6; G. 3.33; F. 4; IV.

Leucophœnicite, $(\text{Mn.Ca.Zn})_5(\text{Mn.Ca.ZnOH})_2(\text{SiO}_4)_3$; Purple-red; H. 5.5-6; G. 3.84; F. 3; V.

4. Not included above.

a. Easily soluble in HCl.

ZINCITE, ZnO ; Deep red to orange-yellow; Cl. basal; H. 4-4.5; G. 5.55; Inf.; III; p. 339.

b. The nitric acid solution shows phosphoric acid with ammonium molybdate.

Hopeite, $\text{Zn}_3(\text{PO}_4)_2 \cdot 4 \text{H}_2\text{O}$; Grayish white; Cl. pinacoidal; H. 2.5-3; G. 2.76; F. 3; IV.

c. Not easily soluble in HCl.

GAHNITE, ZnAl_2O_4 ; Dark green; H. 7.5-8; G. 4.55; Inf.; I; p. 377.

JEFFERSONITE, $(\text{Ca.Mn})(\text{Mg.Fe.Zn})(\text{SiO}_3)_2$; Greenish black to brown; Cl. prismatic; H. 5-6; G. 3.6; F. 4; V; p. 424.

Disluite, $(\text{Zn.Fe.Mn.Mg})(\text{Al.Fe})\text{O}$; Green-black, green, gray; H. 7.5-8; G. 4.5; Inf.; I.

B. *With Von Kobell's flux shows bismuth*; p. 580.

1. The powdered mineral when heated in the closed tube with a few fragments of coal yields an arsenic mirror, p. 585.

a. The S. Ph. bead in R. F. is green (uranium).

Walpurgite, $\text{Bi}_{10}(\text{UO}_2)_3(\text{OH})_{24}(\text{AsO}_4)_4$; Wax-yellow; Cl. pinacoidal; H. 3.5; G. 5.76; F. 1.5; VI.

b. The S. Ph is not green, or shows no uranium.

Atelestite, $(\text{Bi.2 OH})(\text{BiO})_2\text{AsO}_4$; Sulphur-yellow; H. 3-4; G. 6.40; F. 1.5; V.

Rhagite, $3 \text{Bi}(\text{OH})_3 \cdot 2 \text{BiAsO}_4$; Yellow to greenish; Resinous; H. 5; G. 6.80; F. 1.5; Mammillary.

2. Effervesces with warm dilute HCl (carbonates).

a. Yields little or no water.

Bismuthosphærite, $(\text{Bi.O})_2\text{CO}_3$; White to gray; Dull; H. 3-3.5; G. 7.42; F. 1.5; Massive.

b. Yields water.

Bismutite, $(\text{BiO})(\text{Bi.2 OH})\text{CO}_3$; Yellowish to grayish; Dull; H. 4-4.5; G. 6.88.

3. Gelatinizes with HCl.

Eulytite, $\text{Bi}_4(\text{SiO}_4)_3$; Brown, yellow, colorless; Resinous; H. 4.5; G. 6.1; F. 2; I.

Agricolite, $\text{Bi}_4(\text{SiO}_4)_3$; Yellow, brown; H. 3?; G. 6.00; F. 2; V.

4. Soluble in HCl, shows vanadium; p. 576.

Pucherite, BiVO_4 ; Reddish yellow; Cl. basal; H. 4; G. 6.25; F. 2; IV.

5. Shows tellurium.

Montanite, $(\text{Bi}_2\text{OH})_2\text{TeO}_4$; Yellow, green, white; H. 1.5?; Dull; Massive.

C. Yields an antimony coat; § a, p. 584.

1. The HCl solution reduced with tin shows titanium; § b, p. 570.

Lewisite, $(\text{Ca.Fe})_5\text{Ti}_2\text{Sb}_6\text{O}_{24}$; Honey-yellow to brown; Resinous; H. 5.5; G. 4.95; I.

2. In R. F. becomes magnetic.

Tripuyhite, $\text{Fe}_2\text{Sb}_2\text{O}_7$; Greenish yellow; Resinous; G. 5.82; F. 4-5?.

3. In R. F. not magnetic.

Romeite, CaSb_2O_4 ; Honey-yellow; H. 5.5; G. 4.70; II.

Manganostibnite, $\text{Mn}_{10}\text{Sb}_2\text{O}_5$; Black; Compact.

D. Yields a cadmium coat; § a, p. 581.

With soda a sulphur reaction.

Greenockite, CdS ; Honey-, lemon- or orange-yellow; H. 3-3.5; G. 4.95; III; p. 306.

V. In R. F. on coal yields an arsenical odor, or the powdered mineral heated with a few fragments of coal in a closed tube yields an arsenic mirror.

A. In the borax bead it shows cobalt.

ERYTHRITE, $\text{Co}_3(\text{AsO}_4)_2 \cdot 8\text{H}_2\text{O}$; Crimson to peach-red; Pearly; H. 1.5-2.5; G. 2.95; F. 2.5; V; p. 517.

Forbesite, $\text{H}(\text{Ni.Co})\text{AsO}_4 \cdot 3\frac{1}{2}\text{H}_2\text{O}$; Grayish white; Silky; H. 2.5; G. 3.1; Fibrous.

B. With borax shows nickel.

Annabergite, $\text{Ni}_3(\text{AsO}_4)_2 \cdot 8\text{H}_2\text{O}$; Apple-green; H. 1.5-2.5; F. 4; V; Capillary.

Cabrerite, $(\text{Ni.Mg})_3(\text{AsO}_4)_2 \cdot 8\text{H}_2\text{O}$; Apple-green; Pearly; H. 2; G. 2.96; F. 4-5; V.

C. *The residue after treatment in R. F. is magnetic. The bead shows iron.*

1. With soda in R. F. it yields a sulphur reaction.
Pitticite, $\text{Fe}, (\text{AsO}_4), (\text{SO}_4) \cdot \text{H}_2\text{O}?$; Yellowish to reddish brown; H. 2-3; G. 2.35; Massive.

2. No sulphur, contains calcium; § b, p. 566.
Arsenosiderite, $[\text{Fe}_4(\text{OH})_6](\text{Ca} \cdot \text{OH})_3(\text{AsO}_4)_3$; Yellowish to golden brown; Silky; H. 1-2; G. 3.6; F. 3; Fibrous.

Mazapilite, $[\text{Fe}_4(\text{OH})_6]\text{Ca}_3(\text{AsO}_4)_4 \cdot 3 \text{H}_2\text{O}$; Black to brownish red; H. 4.5; G. 3.57; IV.

3. Contains no sulphur or calcium.

PHARMACOSIDERITE, $\text{Fe}(\text{Fe} \cdot \text{OH})_3(\text{AsO}_4)_3 \cdot 6 \text{H}_2\text{O}$; Green, yellow, brown, red; H. 2.5; G. 2.95; F. 1.5-2; I.

SCORODITE, $\text{FeAsO}_4 \cdot 2 \text{H}_2\text{O}$; Pale green to brown; H. 3.5-4; G. 3.29; F. 2-2.5; IV.

Symplesite, $\text{Fe}_3(\text{AsO}_4)_2 \cdot 8 \text{H}_2\text{O}$; Blue to mountain-green; Cl. Pinacoidal; H. 2.5; G. 2.95; F. Difficult V.

D. *Roasted and dissolved in borax on wire it shows manganese.*

1. It dissolves in HCl liberating chlorine.
Synadelphite, $2(\text{Mn} \cdot \text{Al})\text{AsO}_4 \cdot 5 \text{Mn}(\text{OH})_2$; Brownish black to black; H. 4.5; G. 3.47; F. 2-3; V.
Flinkite, $\text{MnAsO}_4 \cdot \text{Mn}(\text{OH})_2$; Greenish brown; H. 4-4.5; G. 3.87; F. 2-3; IV.
Hematolite, $(\text{Al} \cdot \text{Mn})\text{AsO}_4 \cdot 4 \text{Mn}(\text{OH})_2$; brown to red; Cl. basal; H. 3.5; G. 3.35; F. Difficult; III.

2. Soluble in HCl without liberating chlorine.

Brandtite, $\text{Ca}_2\text{Mn}(\text{AsO}_4)_2 \cdot 2 \text{H}_2\text{O}$; White; H. 5-5.5; G. 3.67; F. 2.5-3; VI.

Berzeliite, $(\text{Ca} \cdot \text{Mg} \cdot \text{Mn})_3(\text{AsO}_4)_2$; Sulphur- to orange-yellow; Resinous; H. 5; G. 4.08; F. 3; I.

Larkinite, $\text{Mn}(\text{Mn} \cdot \text{OH})\text{AsO}_4$; Flesh, rose, or yellowish red; Greasy; H. 4-5; G. 4.18; F. 2; V.

Hemafibrite, $\text{Mn}_3(\text{AsO}_4)_2 \cdot 3 \text{Mn}(\text{OH})_2$; F. 2?; IV.

Allactite, $\text{Mn}_3(\text{AsO}_4)_2 \cdot 4 \text{Mn}(\text{OH})_2$; Brownish red; H. 4.5; G. 3.84; F. 2?; V.

E. *The roasted mineral in the S. Ph. bead shows uranium; p. 576.*

Trögerite, $(\text{UO}_2)_3(\text{AsO}_4)_2 \cdot 12 \text{H}_2\text{O}$; Lemon-yellow; Cl. pinacoidal; G. 3.3; F. 2.5; V.

Uranospinite, $\text{Ca}(\text{UO}_2)_3(\text{AsO}_4)_2 \cdot 8 \text{H}_2\text{O}$; Bright green;
Cl. basal; H. 2-3; G. 3.45; IV.

F. Fused with potassium bisulphate in the closed tube, it shows fluorine.

1. It yields a sodium flame (yellow).

Durangite, $\text{Na}(\text{AlF})\text{AsO}_4$; Light to dark orange-red;
C. prismatic; H. 5; G. 4.0; F. 2; V.

2. Shows calcium; § *b*, p. 566.

Tilasite, $\text{Ca}(\text{MgF})\text{AsO}_4$; Gray to violet; Cl. pinacoidal; F. 4.5-5; Foliated.

Svabite, $\text{Ca}_4(\text{CaF})(\text{AsO}_4)_3$; Colorless; Cl. prismatic;
G. 3.5; F. 4.5-5; III.

G. The concentrated HCl solution yields a precipitate with a drop of sulphuric acid (calcium).

Adelite, $\text{Ca}(\text{Mg.OH})\text{AsO}_4$; Gray; H. 5; G. 3.76; V.

Haidingerite, $\text{HCaAsO}_4 \cdot \text{H}_2\text{O}$; White; Pearly; Cl. pinacoidal; H. 1.5-2.5; G. 2.85; F. 2.5; IV.

Pharmacolite, $\text{HCaAsO}_4 \cdot 2 \text{H}_2\text{O}$; White or gray; Pearly;
Cl. pinacoidal; H. 2.5; G. 2.47; F. 2-3; V.

H. Becomes violet with cobalt solution.

Hoernesite, $\text{Mg}_3(\text{AsO}_4)_2 \cdot 8 \text{H}_2\text{O}$; Snow-white; Pearly;
Cl. pinacoidal; H. 1; G. 2.47; F. 2-3; V.

*VI. The nitric acid solution shows phosphoric acid with ammonium molybdate, § *b*, p. 590.*

A. The powdered mineral treated with the R. F. on coal yields a magnetic residue.

1. Yields a lithium flame.

TRIPHYLITE, $\text{Li}(\text{Fe.Mn})\text{PO}_4$; Light blue, green, gray;
resinous; Cl. basal; H. 4.5; G. 3.55; F. 2.5; IV.

2. The borax bead shows manganese.

a. Yields a strong yellow flame (sodium).

Natrophilite, $\text{Na}(\text{Mn.Fe})\text{PO}_4$; Deep wine-yellow;
Resinous; Cl. basal; H. 4.5-5; G. 3.41; F. 2-2.5;
IV.

Dickinsonite, $(\text{Mn.Fe.Ca.Na}_2)_3(\text{PO}_4)_2 \cdot \frac{1}{3} \text{H}_2\text{O}$; Olive-oil
or grass-green; Cl. basal; H. 3.5-4; G. 3.34; F.
2.5; V.

Fillowite, $(\text{Mn.Fe.Ca.Na}_2)_3(\text{PO}_4)_2 \cdot \frac{1}{3} \text{H}_2\text{O}$; Wax yellow to
brown; Greasy; Cl. basal; H. 4.5; G. 3.43; F.
2.5-3; V.

b. It will not yield a yellow flame.

TRIPLITE, $(\text{Fe.Mn})(\text{Mn.F})\text{PO}_4$; Chestnut to blackish brown; Resinous; H. 4.6; F. 2.5; V.

Yields water.

Triploidite, $(\text{Mn.Fe})(\text{Mn.OH})\text{PO}_4$; Yellow to reddish brown; Cl. pinacoidal; H. 4.5-5; G. 3.70; F. 3; V.

Childrenite, $(\text{Fe.Mn})(\text{Al.2 OH})\text{PO}_4.\text{H}_2\text{O}$; Yellowish brown to brownish black; Cl. pinacoidal; H. 4.5-5; G. 3.20; F. 4; IV.

Perpurite, $2(\text{Mn.Fe})\text{PO}_4.\text{H}_2\text{O}$; Reddish purple; H. 4-4.5; G. 3.15; F. 2.

3. The borax bead shows iron only.

a. With soda it shows sulphur.

Diadochite, $2(\text{Fe.OH})\text{SO}_4.2 \text{FePO}_4.\text{H}_2\text{O}$; Yellow or yellowish brown; Resinous; H. 3; G. 2.03; F. 3?; V.

b. The concentrated HCl solution shows calcium; § b, p. 566.

Borickite, $\text{Ca}(\text{Fe.2 OH})_4(\text{PO}_4)_2.3 \text{H}_2\text{O}$; Reddish brown; Waxlike; H. 3.5; G. 2.7; F. 3; Massive.

Calcioferrite, $\text{Ca}_3(\text{Fe.OH})_3(\text{PO}_4)_4.8 \text{H}_2\text{O}$; Sulphur to greenish yellow; Pearly; H. 2.5; G. 2.52; Massive.

4. Yields aluminum; § b, p. 568.

Barrandite, $(\text{Al.Fe})\text{PO}_4.2 \text{H}_2\text{O}$; Pale blue, green, or yellow; H. 4.5; G. 2.57; Radiated.

LAZULITE, $(\text{Mg.Fe})(\text{AlOH})_2(\text{PO}_4)_2$; Azure-blue; Cl. prismatic; H. 5-5.5; G. 3.06; F. Difficult; V; p. 438.

5. Phosphates of iron only.

VIVIANITE, $\text{Fe}_3(\text{PO}_4)_2.8 \text{H}_2\text{O}$; Blue, bluish green, white; Cl. pinacoidal; H. 1.52; G. 2.63; F. 2-2.5; V; p. 516.

Ludlamite, $\text{Fe}_5(\text{Fe.OH})_2(\text{PO}_4)_4.8 \text{H}_2\text{O}$; Pale green; Cl. basal; H. 3-4; G. 3.12; F. 2.5; V; Tabular.

DUFRENITE, $\text{Fe}_2(\text{OH})_3\text{PO}_4$; Dull olive- to black-green; Silky; H. 3.5-4; G. 3.31; F. 2.5; IV; p. 510.

Beraunite, $(\text{Fe.OH})_3(\text{PO}_4)_2.2\frac{1}{2} \text{H}_2\text{O}$; Reddish brown; Cl. pinacoidal; G. 2.95; F. 3; V; Foliated.

Phosphosiderite, $2 \text{FePO}_4.3\frac{1}{2} \text{H}_2\text{O}$; Pale red or reddish violet; Cl. pinacoidal; H. 3-4; G. 2.76; F. 2.5; IV.

Strengite, $\text{FePO}_4.2 \text{H}_2\text{O}$; Pale red or reddish violet; H. 3-4; G. 2.87; F. 2.5; IV.

Koninckite, $\text{FePO}_4 \cdot 3\text{H}_2\text{O}$; Yellow; H. 3.5; G. 2.3; F. 2.5; Radiated.

Cacoxenite, $\text{Fe}_2(\text{OH})_3\text{PO}_4 \cdot 4\frac{1}{2}\text{H}_2\text{O}$; Golden-yellow; Silky; H. 3-4; G. 3.38; F. 2.5; Radiated.

B. The roasted residue is not magnetic.

1. The borax bead shows manganese.

Fairfieldite, $\text{Ca}_2\text{Mn}(\text{PO}_4)_2 \cdot 2\text{H}_2\text{O}$; White to greenish white; Cl. pinacoidal; H. 3.5; G. 3.15; F. 4-4; 5; VI.

Reddingite, $\text{Mn}_3(\text{PO}_4)_2 \cdot 3\text{H}_2\text{O}$; Pale rose to brown; H. 3-3.5; G. 3.10; F. 2.5-3; IV.

2. The S. Ph. bead in R. F. is green (uranium).

AUTUNITE, $\text{Ca}(\text{UO}_2)_2(\text{PO}_4)_2 \cdot 8\text{H}_2\text{O}$; Lemon, to sulphur-yellow; Cl. basal; H. 2-2.5; G. 3.12; F. 3; IV; Tabular, p. 520.

Uranocircite, $\text{Ba}(\text{UO}_2)_2(\text{PO}_4)_2 \cdot 8\text{H}_2\text{O}$; Yellowish green; Cl. basal; H. 2-2.5; G. 3.53; F. 3?; IV; Tabular.

Phosphuranylite, $(\text{UO}_2)_3(\text{PO}_4)_2 \cdot 6\text{H}_2\text{O}$; Deep lemon-yellow; Pearly; F. 3-4?; IV.

C. The concentrated HCl solution yields a precipitate with sulphuric acid (calcium).

1. Yields little or no water.

APATITE, $\text{Ca}_4(\text{CaF})(\text{PO}_4)_3$; Green, blue, brown, white; Cl. basal; H. 5; G. 3.15; G. 5-5.5; III; p. 508.

2. Yields water in the closed tube.

HERDERITE, $\text{Ca}[\text{Be}(\text{OH.F})]\text{PO}_4$; White, pale green or yellow; H. 5; G. 3.00; F. 4; V.

Hydro-herderite, $\text{Ca}(\text{Be.OH.F})\text{PO}_4$; White, yellow, pale green; H. 5; G. 2.95; F. 4; V.

Cirrolite, $(\text{Ca.OH})_3\text{Al}_2(\text{PO}_4)_3$; White, pale yellow; H. 5-6; G. 3.08; F. 4; Massive.

Monetite, HCaPO_4 ; Yellowish white; Cl. pinacoidal; H. 3.5; G. 2.75; F. 3; VI.

Collophanite, $\text{Ca}_3(\text{PO}_4)_2 \cdot \text{H}_2\text{O}$; White, yellow; Dull; H. 2-2.5; G. 2.70; F. 4.5; Amorphous.

Tavistokite, $\text{Ca}_3\text{Al}_2(\text{OH})_6(\text{PO}_4)_2$; White, pearly; F. Difficult; Acicular.

Svanbergite, $(\text{SO}_4)(\text{PO}_4)$, Al, Ca.H₂O?; Yellow, brown, rose-red; Cl. basal; H. 5; G. 3.30; F. Difficult; III.

Hamlinite, $(\text{Sr.OH})(\text{Al.2OH})_3\text{P}_2\text{O}_7$; White to yellowish white; Cl. basal. H. 4.5; G. 3.23; F. 4; III.

Martinite, $\text{H}_2\text{Ca}_5(\text{PO})_4\cdot\text{H}_2\text{O}$; White, yellow; G. 3.9; F. Difficult; III.

3. Yields much water.

Isoclasite, $\text{Ca}(\text{Ca}\cdot\text{OH})\text{PO}_4\cdot 2\text{H}_2\text{O}$; White; Cl. pinacoidal; H. 1.5; G. 2.92; F. 4?; V.

Brushite, $\text{H}\text{Ca}\text{PO}_4\cdot 2\text{H}_2\text{O}$; Colorless, pale yellow; Cl. pinacoidal; H. 2-2.5; G. 2.20; F. 3; V.

Goyazite, $\text{Ca}_3\text{Al}_{10}\text{P}_2\text{O}_{23}\cdot 9\text{H}_2\text{O}$; Yellowish white; Cl. basal; H. 5; G. 3.26; F. Difficult.

D. *Becomes blue with cobalt solution (aluminum). Fusibility above 5.*

Variscite, $\text{AlPO}_4\cdot 2\text{H}_2\text{O}$; White, apple- to emerald-green; Cl. prismatic; H. 4; F. Difficult; G. 2.4; IV.

Callainite, $\text{AlPO}_4\cdot 2\frac{1}{2}\text{H}_2\text{O}$; Apple- to emerald-green; H. 3.5-4; G. 2.51; Massive.

Zepharovichite, $\text{AlPO}_4\cdot 3\text{H}_2\text{O}$; Greenish to grayish green; H. 5.5; G. 2.37; Compact.

Minervite, $\text{AlPO}_4\cdot 3\frac{1}{2}\text{H}_2\text{O}$; White; Massive.

GIBBSITE, $\text{AlPO}_4\cdot 4\text{H}_2\text{O}$; White; Massive; Foliated; p. 365.

WAVELLITE, $(\text{Al}\cdot\text{OH})_3(\text{PO}_4)_2\cdot 5\text{H}_2\text{O}$; White, yellow, green, brown; H. 3-4; G. 2.33; IV; p. 510.

Augelite, $\text{Al}_2(\text{OH})_3\text{PO}_4$; White; Cl. prismatic; H. 4.5-5; G. 2.70; V.

Peganite, $\text{Al}_2(\text{OH})_3\text{PO}_4\cdot 1\frac{1}{2}\text{H}_2\text{O}$; Dark to light green; H. 3-3.5; G. 2.50; IV.

Fischerite, $\text{Al}_2(\text{OH})_3\text{PO}_4\cdot 2\frac{1}{2}\text{H}_2\text{O}$; Grass- to olive-green; H. 5; G. 2.46; IV.

Sphærite, $\text{Al}_5(\text{OH})_9(\text{PO}_4)_2\cdot 12\text{H}_2\text{O}$; Light gray or blue; H. 4; G. 2.53; Globular.

Evansite, $\text{Al}_3(\text{OH})_6\text{PO}_4\cdot 6\text{H}_2\text{O}$; White, pale yellow or blue; H. 3.5-4; G. 1.94; Massive.

LAZULITE, $(\text{Mg}\cdot\text{Fe})(\text{Al}\cdot\text{OH})_2(\text{PO}_4)_2$; Azure-blue; H. 5.5; G. 3.06; V; p. 438.

Florencite, $\text{Al}_3\text{Ce}(\text{OH})_6(\text{PO}_4)_2$; Pale yellow; Greasy; Cl. basal; G. 3.58; III.

E. *Not included above.*

1. Heated in the closed tube yields the odor of ammonia.

Struvite, $\text{NH}_4\text{Mg}\text{PO}_4\cdot 6\text{H}_2\text{O}$; White, yellow, brown; H. 2; G. 1.65; F. 3; IV.

Stercorite, $\text{H}(\text{NH}_4)\text{Na}\text{PO}_4\cdot 4\text{H}_2\text{O}$; White, yellow, brown; H. 2; G. 1.6; F. 1; V.

2. With Turner's flux it yields a boric acid flame (bright green).

Lüneburgite, $\text{Mg}_3(\text{PO}_4)_2 \cdot \text{B}_2\text{O}_3 \cdot 8\text{H}_2\text{O}$; White; G. 2.05; Fibrous, earthy.

3. Yields a strong sodium flame (yellow).

Beryllonite, NaBePO_4 ; White; Cl. basal; H. 5.5-6; G. 2.84; F. 3-3.5; IV.

4. Yields a lithium flame (red).

AMBLYGONITE, $\text{Li}(\text{Al.F})\text{PO}_4$; White, pale green, blue; Cl. basal; H. 6; G. 3.08; F. 2; VI; p. 512.

Montebrasite, $\text{Li}[\text{Al}(\text{OH.F})]\text{PO}_4$; White, blue, pale green; Cl. basal; H. 6; G. 3.00; VI.

5. The HCl solution yields a precipitate of magnesium ammonium phosphate with ammonia.

Wagnerite, $\text{Mg}(\text{MgF})\text{PO}_4$; Pale yellow, gray, red; H. 5.5; G. 3.06; F. 3.5-4; V.

Bobierite, $\text{Mg}_3(\text{PO}_4)_2 \cdot 8\text{H}_2\text{O}$; White; pinacoidal; H. 2.5; G. 2.43; V.

6. Phosphates of the rare earths; § a, p. 575.

MONAZITE, $(\text{Ce.La.Di})\text{PO}_4$; Yellowish to reddish brown; H. 5-5.5; G. 5.10; V; p. 507.

XENOTIME, YPO_4 ; Yellow to reddish brown; Cl. prismatic; H. 4-5; G. 4.53; Inf.; II.

Rhabdophanite, $(\text{La.Di.Y.Er})\text{PO}_4 \cdot \text{H}_2\text{O}$; Brown, pink, yellow, white; H. 3.5; G. 3.95; F. Difficult; Massive.

Churchite, $\text{Ca}_3\text{Ce}_{10}(\text{PO}_4)_{12} \cdot 24\text{H}_2\text{O}?$; Smoky-gray, pinkish; H. 3-3.5; G. 3.15.

- VII. The powdered mineral heated in R. F. on coal becomes magnetic.

A. *Effervesces in warm dilute HCl (carbonates).*

SIDERITE, FeCO_3 ; Light to dark brown; Cl. rhombohedral; H. 3.5-4; G. 3.85; Inf.; III; p. 388.

Ankerite, $\text{Ca}(\text{Mg.Fe.Mn})(\text{CO}_3)_2$; Gray, brown; Cl. rhombohedral; H. 3.5-4; G. 3.03; Inf.; III.

Breunnerite $(\text{Mg.Fe})\text{CO}_3$, Brown, gray; Cl. rhombohedral; H. 3.5-4.5; G. 3; Inf.; III.

B. *The finely powdered mineral is soluble in boiling concentrated HCl. leaving no residue of silica.*

1. Yields little or no water.

Hematite, Fe_2O_3 ; Red to reddish black; H. 5.5-6; G. 5.10; Inf.; III; p. 343.

2. Yields water.

LIMONITE, $\text{Fe}_4\text{O}_3(\text{OH})_6$; Yellow, brown to brownish black; Silky, dull; H. 5-5.5; G. 3.80; Inf.; Massive; p. 363.

Göthite, $\text{FeO}(\text{OH})$; Yellow, brown to brownish black; Dull; H. 5-5; G. 4.37; Inf.; IV; p. 363.

Xanthosiderite, $\text{Fe}_2\text{O}(\text{OH})_4$; Golden-yellow to brown; Silky, pitchy; H. 2.5; Inf.; Earthy, acicular.

Turgite, $\text{Fe}_4\text{O}_5(\text{OH})_2$, Red to reddish brown; Dull; H. 5-6; G. 4.14; Inf.; Incrusted.

a. Fused with soda it yields a sulphur reaction.

Planoferrite, $\text{Fe}_2(\text{OH})_4\text{SO}_4 \cdot 13\text{H}_2\text{O}$; Yellowish green; H. 3. Compare sulphates of iron, p. 635.

b. After the separation of iron it shows magnesium; § c, p. 567.

Pyroaurite, $\text{Fe}(\text{OH})_3 \cdot 3\text{Mg}(\text{OH})_2 \cdot 3\text{H}_2\text{O}$; Golden-yellow to silver-white; Pearly; H. 2-3; Inf.; G. 2.07; III.

C. Gelatinizes with HCl; p. 591.

1. Yields little or no water in the closed tube.

ALLANITE, $(\text{Ca.Fe})_2(\text{Al.Ce.Fe})_2(\text{Al.OH})(\text{SiO}_4)_3$; Brown to pitch-black; Resinous; H. 5.5-6; G. 3.90; F. 2.5; V; p. 468.

ILVAITE, $\text{CaFe}_2(\text{Fe.OH})(\text{SiO}_4)_2$; Iron-black; H. 5.5-6; G. 4.05; F. 2.5; IV; p. 472.

FAYALITE, Fe_2SiO_4 ; Yellow to dark yellowish green; Resinous; H. 6.5; G. 4.32; F. 4; IV; p. 450.

a. Fused with soda and niter on wire, shows manganese; § b, p. 574.

Hortonolite, $(\text{Fe.Mg.Mn})_2\text{SiO}_4$; Yellow to dark yellowish green; Resinous; H. 6.5; G. 4.03; F. 4.5; IV.

Kenebelite, $(\text{Fe.Mn.Mg})_2\text{SiO}_4$; Gray, brown, green; Greasy; Cl. pinacoidal; H. 6.5; G. 3.95; IV.

2. Yields water in the closed tube.

Cronstedtite, $\text{H}_8\text{Fe}''_4\text{Fe}'''_4\text{Si}_3\text{O}_{20}$; Black to brownish black; Cl. basal; H. 3.5; G. 3.35; F. 4; III.

Thuringite; $\text{H}_{18}\text{Fe}_8(\text{Al.Fe})_8\text{Si}_6\text{O}_{41}$; Olive to pistachio-green; Dull; H. 2.5; G. 3.18; F. 4; Compact.

D. Decomposed in HCl without gelatinizing, leaving a residue of silica; § d, p. 591.

1. Fused with soda and niter on wire it shows manganese, § b, p. 574.

Pyrosmalite, $H_7(Fe.Cl)(Fe.Mn)_4(SiO_4)_4$; Olive-green to brown; Cl. basal; H. 4-4.5; G. 3.16; F. 3; III.
ASTROPHYLLITE, $(K.Na.H)_4(Fe.Mn.Mg.Ca)_4Ti(SiO_4)_4$; Bronze to golden-yellow; Cl. pinacoidal; H. 3; G. 3.35; F. 3; IV.

2. Shows no manganese.

LEPIDOMELANE, $(K.H)_2Fe''_2(Fe.Al)_2(SiO_4)_3$; Black to greenish black; Cl. basal; H. 3; G. 3.1; γ 4.5-5; V.

ANDRADITE, $Ca_3Fe_2(SiO_4)_3$; Wine, yellowish, green, brown; H. 7; G. 3.85; F. 3.5; I; p. 444.

Stilpnomelane, $H_6(Fe.Mg)_2(Fe.Al)_2Si_5O_{18}$; Greenish to yellowish bronze; H. 3; G. 2.75; F. 4.5; Foliated.

Hisingerite, H, Fe, Fe, Mg, Si, O?; Black to brownish black; H. 3; 2.75; F. Difficult; Amorphous.

Chloropal, $H_6Fe_2(SiO_4)_3.2H_2O$; White, olive, blackish, yellowish green; H. 2.5-3; G. 1.87; F. Difficult; Amorphous.

E. Insoluble or only slightly attacked by HCl.

1. Yields little or no water.

a. In S. Ph. an emerald green bead (chromium).

CHROMITE, $FeCr_2O_4$; Brownish black; H. 7.5-8; G. 4.45; Inf.; I; p. 376.

b. The S. Ph. bead reduced with tin on coal, then dissolved in dilute HCl, shows tungsten. § b. p. 587.

WOLFRAMITE, $(Mn.Fe)WO_4$; Brown to black; Cl. pinacoidal; H. 5-5.5; G. 7.35; F. 4; V; p. 542.

c. Fuses with intumescence and colors the flame yellow (sodium).

ARFVEDSONITE, $(Fe.Na_2.Ca)_4(SiO_3)_4.Fe_2(Al.Fe)_2Si_2O_{12}$; Black; Cl. prismatic; H. 6; G. 3.45; F. 3.5; V; p. 419.

Crocidolite, $NaFe(SiO_3)_2(Fe.Mg.Ca)SiO_3$; Lavender blue; H. 6-6.5; G. 3.43; F. 3.5; Fibrous.

Riebeckite, $2NaFe(SiO_3)_2.(Fe.Ca)SiO_3$; Black; Cl. prismatic; H. 6-6.5; G. 3.43; F. 3; V.

Ænigmatite, $(Fe.Mn)(Fe.Al).Na.(Ti.Si)O?$; Black; Cl. prismatic; H. 6; G. 3.75; F. 3; VI.

d. Fuses quietly, or with difficulty.

ALMANDITE, $Fe_3Al_2(SiO_4)_3$; Deep to brownish red; H. 7-7.5; G. 4.15; F. 3; I; p. 444.

Babingtonite, $(\text{Ca.Mn.Fe})\text{SiO}_3.\text{Fe}_2(\text{SiO}_3)_3$; Greenish black to black; H. 5.5-6; G. 3.36; F. 3-3.5; VI.

ACMITE, $\text{NaFe}(\text{SiO}_3)_2$; Greenish to brownish black; Cl. prismatic; H. 6-6.5; G. 3.50; V.

HYPERSTHENE, $(\text{Mg.Fe})\text{SiO}_3$; Greenish black to bronze-brown; Cl. pinacoidal; H. 5-6; G. 3.45; F. 5; IV; p. 421.

2. Yields water.

BIOTITE, $(\text{K.H})_2(\text{Mg.Fe})_2(\text{Al.Fe})_2(\text{SiO}_4)_3$; Green to greenish black; C. basal; H. 2.5-3; G. 2.90; F. 5; V; p. 492.

Chloropal, $\text{H}_6\text{Fe}_2(\text{SiO}_4)_3.2\text{H}_2\text{O}$; Greenish yellow to pistachio-green; H. 2-4; G. 3.87; F. Difficult; Amorphous.

Compare minerals containing small amounts of iron in sections below, some of which may at times become magnetic.

VIII. After intense ignition in the forceps, it yields an alkaline reaction with turmeric paper, hardness below 5.

A. *Effervesces with hot dilute HCl, and dissolves, leaving little or no residue when pure (carbonates).*

1. After intense ignition in the forceps it yields a green flame (barium).

WITHERITE, BaCO_3 ; White to gray; H. 3.5; G. 4.3; F. 2.5-3; IV; p. 394.

BARYTOCALCITE, $\text{BaCa}(\text{CO}_3)_2$; White, gray, yellow, green; Cl. prismatic; H. 4; G. 3.65; F. Difficult; V; p. 395.

Bromlite, $(\text{Ca.Ba})\text{CO}_3$; White, gray, cream; H. 4-4.5; G. 3.72; F. Difficult; IV.

2. It yields a red flame (strontium).

STRONTIANITE, SrCO_3 ; White, gray, yellow, green; Cl. prismatic; H. 3.5-4; G. 3.70; IV; p. 395.

3. After intense ignition it yields a carmine flame (calcium).

CALCITE, CaCO_3 ; White and variously tinted; Cl. rhombohedral; H. 3; G. 2.72; Inf.; III; p. 379.

ARAGONITE, CaCO_3 ; White and variously tinted; Cl. pinacoidal; H. 3.5-4; Inf.; IV; p. 392.

DOLOMITE, $\text{CaMg}(\text{CO}_3)_2$; White and variously tinted; Cl. rhombohedral; H. 3-4; G. 2.85; Inf.; III; p. 386.

a. Yields a fluorine reaction; § a, p. 589.

- Parisite**, $\text{Ce}(\text{CeF})(\text{CaF})(\text{CO}_3)_3$; Yellowish brown to brown; Cl. basal; H. 4.5; Inf.; G. 4.36; III.
- b. In the closed tube yields water.
Thaumasite, $\text{CaCO}_3 \cdot \text{CaSiO}_3 \cdot \text{CaSO}_4 \cdot 1.5 \text{H}_2\text{O}$; White; H. 3.5; G. 1.87; F. Difficult; III; Fibrous.
- c. In S. Ph. a green bead (uranium).
Uranothallite, $\text{Ca}_2\text{U}(\text{CO}_3)_4 \cdot 10 \text{H}_2\text{O}$; Yellowish green; H. 2.5–3; IV; Tabular.
4. Upon ignition in the forceps it yields an intense yellow flame (sodium).
- a. In the closed tube it yields water.
GAYLUSSITE, $\text{Na}_2\text{Ca}(\text{CO}_3)_2 \cdot 5 \text{H}_2\text{O}$; White to gray; Cl. prismatic; H. 2–3; G. 1.99; F. 1.5; V; p. 401.
Dawsonite, $\text{Na}(\text{Al}_2\text{OH})\text{CO}_3$; White; H. 3.5; G. 2.40; F. 4.5–5; V; Radiated.
Pirssonite, $\text{Na}_2\text{Ca}(\text{CO}_3)_2 \cdot 2 \text{H}_2\text{O}$; White to gray; H. 3–3.5; G. 2.35; F. 1.5; IV.
- b. In the closed tube it yields no water.
The nitric acid solution yields a precipitate with AgNO_3 (chlorine).
Northupite, $\text{MgNa}_2(\text{CO}_3)_2\text{Cl}$; Colorless to brown; H. 3.5–4; G. 2.38; F. 1; I.
Fused with soda it yields a sulphur reaction.
Tychite, $\text{MgNa}_6(\text{CO}_3)_4\text{SO}_4$; Colorless; H. 3.5; G. 2.58; F. 1; I.
5. It contains magnesium as the base; § a, p. 567.
- a. It yields no water in the closed tube.
MAGNESITE, MgCO_3 ; White, gray, yellow, brown; Cl. rhombohedral; H. 3.5–4.5; G. 3.06; Inf.; III; p. 385.
Brunnerite, $(\text{Mg}, \text{Fe})\text{CO}_3$. Brown, gray; Cl. rhombohedral; 3.5–4.5; G. 3; Inf.; III; p. 385.
- b. Yields water.
Hydromagnesite, $\text{Mg}_2(\text{Mg}, \text{OH})_2(\text{CO}_3)_3 \cdot 3 \text{H}_2\text{O}$; White; H. 3.5; G. 2.15; Inf.; V.
Lansfordite, $\text{Mg}_2(\text{Mg}, \text{OH})_2(\text{CO}_3)_3 \cdot 21 \text{H}_2\text{O}$; White; H. 2.5; G. 1.54; Cl. basal; Inf.; VI.
Hydrogioberite, $(\text{Mg}, \text{OH})_2\text{CO}_3 \cdot 2 \text{H}_2\text{O}$; White; Cl. prismatic; G. 2.16; Inf.; Compact.
Nesquehonite, $\text{MgCO}_3 \cdot 3 \text{H}_2\text{O}$; White; Cl. prismatic; H. 2.5; G. 1.84; Inf.; IV.

B. Fused with soda and coal dust in the R. F. on coal it yields a sulphur reaction on silver; § b, p. 587.

1. Yields a barium flame (green).

BARITE, BaSO_4 ; White, blúe, yellow, red; Cl. basal and prismatic; H. 3.5; G. 4.5; F. 4; IV; p. 528.

2. Yields a red flame (strontium).

CELESTITE, SrSO_4 ; White, blue, red; Cl. basal, prismatic; H. 3-3.5; G. 3.97; F. 3.5-4; IV; p. 530.

3. It yields a calcium flame (carmine), or a calcium reaction; § a, p. 566.

a. Yields no water.

ANHYDRITE, CaSO_4 ; White, blue, red, gray; Cl. 3 pinacoidals; H. 3-3.5; G. 2.95; F. 3-3.5; IV; p. 531.

Glauberite, $\text{CaNa}_2(\text{SO}_4)_2$; White to gray; Cl. Basal; H. 2.5-3; G. 2.75; F. 1.5-2; V.

Oldhamite, CaS ; Pale chestnut-brown; Cl. cubic; H. 4; G. 2.58; F. Difficult; I.

b. Yields water.

GYPSUM, $\text{CaSO}_4 \cdot 2\text{H}_2\text{O}$; White, gray, reddish; Cl. pinacoidal; H. 2; G. 2.32; F. 3; V; p. 536.

c. Yields a yellow flame (sodium).

Whettevillite, $\text{CaNa}_2(\text{SO}_4)_2 \cdot 4\text{H}_2\text{O}$; White; Silky; G. 1.81; F. 1.5-2; Acicular.

d. Yields a potassium flame through the blue glass.

Polyhalite, $\text{Ca}_2\text{MgK}_2(\text{SO}_4)_4 \cdot 2\text{H}_2\text{O}$; Brick-red to yellow; Cl. pinacoidal; H. 2.5-3; G. 2.77; F. 2; V?.

Syngenite, $\text{CaK}_2(\text{SO}_4)_2 \cdot 2\text{H}_2\text{O}$; White; Cl. pinacoidal; H. 2.5; G. 2.60; F. 1.5-2; V.

Ettringite, $(\text{Ca} \cdot \text{OH})_6(\text{SO}_4)_3 \cdot 2\text{Al}(\text{OH})_3 \cdot 24\text{H}_2\text{O}$; White; H. 2-2.5; G. 1.75; F. 3; III.

C. Fused with potassium bisulphate in the closed tube yields a fluorine reaction; § a, p. 589.

1. Yields little or no water.

a. Will not become blue with cobalt solution.

FLUORITE, CaF_2 ; White, green, yellow, violet, pink; Cl. Octahedral; H. 4; G. 3.18; F. 3; I; p. 331.

b. Becomes blue with cobalt solution.

CRYOLITE, Na_3AlF_6 ; White to brownish; Cl. pinacoidal; H. 2.5; G. 2.97; F. 1.5; V; p. 333.

Chiolite, $5\text{NaF} \cdot 3\text{AlF}_3$; Snow-white; H. 3.5-4; G. 2.95; F. 1.5; II.

2. Yields water.

Thomsenolite, $\text{NaCaAlF}_6 \cdot \text{H}_2\text{O}$; White to brown; Cl. basal; H. 2; G. 2.93; F. 1.5; V.

Pachnolite, $\text{NaCaAlF}_6 \cdot \text{H}_2\text{O}$; White; H. 3; G. 2.98; F. 1.5; V.

Gearksutite, $\text{CaF}_2\text{Al}(\text{F.OH})_3 \cdot \text{H}_2\text{O}$; White; Dull; H. 2; F. 1.5; Earthy.

Prosopite, $\text{CaF}_2 \cdot 2\text{Al}(\text{F.OH})_3$; White to gray; Cl. prismatic; H. 4.5; G. 2.80; F. Difficult; V.

D. *Not included above.*

1. Becomes pink with cobalt solution (magnesia).

a. Yields water.

BRUCITE, $\text{Mg}(\text{OH})_2$; White, gray, green; Pearly; Cl. basal; H. 2.5; G. 2.39; Inf.; III; p. 362.

TALC, $\text{H}_2\text{Mg}_3(\text{SiO}_3)_4$; Apple-green, gray, white; Pearly; Cl. basal; H. 1; G. 2.80; F. 5; Foliated.

b. Yields no water.

Periclase, MgO ; White, gray, dark green; Cl. cubic; H. 5.5; G. 3.8; Inf.; I.

2. Becomes blue with cobalt solution.

Hydrotalcite, $\text{Mg}_3\text{Al}(\text{OH})_6 \cdot 3\text{H}_2\text{O}$; White; Pearly; Cl. basal; H. 2; G. 2.07; Inf.; III.

3. With Turner's flux it yields a boric acid flame (bright green).

ULEXITE, $\text{NaCaB}_5\text{O}_9 \cdot 8\text{H}_2\text{O}$; White; Silky; H. 1, G. 1.55; F. 1.5; Fibrous; p. 524.

4. Heated in the closed tube yields iodine.

Dietzeite, $7 \text{Ca}(\text{IO}_3)_2 \cdot 8 \text{CaCrO}_4$; Golden-yellow; H. 3-4; G. 3.70; F. 1.5; V. Green in S. Ph.

Lautarite, $\text{Ca}(\text{IO}_3)_2$; Sulphur-yellow to colorless; Cl. prismatic; N. 3.5-4; G. 4.59; F. 1.5; V.

Some silicates may contain enough calcite to yield an alkaline reaction after ignition; in general their hardness will be above 5 and are not placed in this group; compare the silicates beyond.

IX. With Turner's flux it yields a bright green flame (boric acid).

A. *Soluble in HCl.*

1. Yields little or no water.

BORACITE, $\text{Mg}_7\text{Cl}_2\text{B}_{16}\text{O}_{30}$; White, gray, green, brown; H. 7; G. 2.95; F. 3; I; p. 522.

Rhodizite, $\text{K}(\text{AlO})_2(\text{BO}_2)_3$; white; H. 8; G. 3.41; F. 4.5; I.

Pinakiolite, $3 \text{MgB}_2\text{O}_4 \cdot \text{Mn}''\text{Mn}'''\text{O}_4$; Black; Cl. pinacoidal; H. 6; G. 3.88; F. 5; IV.

2. Yields water.

a. In the borax bead shows manganese.

Sussexite, $\text{H}(\text{Mn.Mg.Zn})\text{BO}_3$; Gray; Silky; H. 3; G. 3.12; F. 2.5; IV?; Fibrous.

b. The concentrated HCl solution yields a precipitate with H_2SO_4 (calcium); § *b*, p. 566.

COLEMANITE, $\text{Ca}_2\text{B}_6\text{O}_{11} \cdot 5 \text{H}_2\text{O}$; White; Cl. pinacoidal; H. 4-4.5; G. 2.42; F. 1.5; V; p. 524.

Hydroboracite, $\text{CaMgB}_6\text{O}_{11} \cdot 6 \text{H}_2\text{O}$; White; H. 2; G. 1.95; F. 1.5; Fibrous, foliated.

Bechilite, $\text{CaB}_4\text{O}_{7.4} \text{H}_2\text{O}$; Massive.

c. Yields magnesium reaction § *a*, p. 567.

Szaibelyite, $\text{Mg}_5\text{B}_4\text{O}_{11} \cdot 1\frac{1}{2} \text{H}_2\text{O}$; White to yellow; H. 3-4; G. 3.0; Nodular, acicular.

Pinnoite, $\text{MgB}_2\text{O}_4 \cdot 3 \text{H}_2\text{O}$; Sulphur to straw-yellow; H. 3-4; G. 3.3; F. 3; II.

Heintzite, $\text{KMg}_2\text{B}_{11}\text{O}_{19} \cdot 7 \text{H}_2\text{O}$; White; Cl. pinacoidal; H. 4-5; G. 2.13; F. 1; V.

B. *The finely powdered mineral gelatinizes with HCl.*

DATOLITE, $\text{Ca}(\text{B.OH})\text{SiO}_4$; White, pale green, yellow; H. 5-5.5; G. 2.95; F. 2.5; V; p. 463.

Bakerite, $8 \text{CaO}, 2 \text{B}_2\text{O}_3, 6 \text{SiO}_2 \cdot 6 \text{H}_2\text{O}$; White to pale green; Dull; H. 4.5; G. 2.13; F. 1; Massive.

C. *Insoluble in HCl or only slightly soluble.*

1. Yields water.

Howlite, $\text{H}_5\text{Ca}_2\text{B}_5\text{SiO}_{14}$; White; H. 3.5; G. 2.59; F. Difficult; Nodular, fibrous.

Hambergite, $\text{Be}(\text{Be.OH})\text{BO}_3$; Grayish white; Cl. pinacoidal; H. 7.5; G. 2.35; Inf; IV.

2. Yields little or no water.

AXINITE, $\text{H}_2(\text{Ca.Fe.Mn})_4(\text{BO})\text{Al}_3(\text{SiO}_4)_5$; Clove-brown, green, yellow, gray; Cl. pinacoidal; H. 6.5-7; G. 3.29; F. 2.5-3; VI; p. 469.

TOURMALINE, complex borosilicate; Various colors; H. 7-7.5; G. 3.14; F. 3-5; III; p. 473.

Danburite, $\text{CaB}_2(\text{SiO}_4)_2$; White to pale yellow; H. 7; G. 3.00; F. 3.5-4; Nodular, fibrous.

Homilite, $(\text{Ca.Fe})_3(\text{BO})_2(\text{SiO}_4)_2$; Brownish black to black; Resinous; H. 5; G. 3.38; F. 2; V.

Cappelenite, $\text{BaY}_6\text{B}_6\text{Si}_3\text{O}_{25}$; Greenish brown; H. 6-6.5; G. 4.41; F. 4-5; III.

a. Yields a titanium reaction § b, p. 570.

Warwickite, $(\text{Mg.Fe})_4\text{TiB}_2\text{O}_9$; Hair-brown; Dull; Cl. pinacoidal; H. 3-4; G. 3.36; Inf.; IV.

b. Becomes blue with cobalt solution.

Jeremejevit, AlBO_3 ; White to pale yellow; H. 6.5; G. 3.28; Inf.; III.

3. Contains the rare earths; § a, p. 572.

Melanocerite, Si, Ta, B, Ce, La, Di, Y, Ca, Na, H, F, ?; Deep brown to black; Inf.; Greasy; H. 5-6; G. 4.13; III.

Caryocerite, Si, Ta, B, Th, Ce, La, Di, Y, Ca, Na, H, F; Nut-brown; Greasy; H. 5-6; G. 4.29; Inf.; III.

X. The finely powdered mineral dissolved in borax on wire in considerable quantities in the O.F. is violet-red when cold (manganese).

A. *The borax bead is powdered, dissolved in 1 cc. of dilute HCl and the solution is reduced with tin when it becomes blue; § b, p. 587.*

HÜBNERITE, MnWO_4 ; Brown to brownish black; Resinous; Cl. pinacoidal; H. 5-5.5; G. 7.2; F. 4; V; p. 542.

Mangano-columbite, MnCl_2O_6 ; Reddish to dark brown; Resinous; Cl. pinacoidal; H. 5; G. 6.6; Inf.; IV.

B. *The solution is green (vanadium).*

Ardennite, $\text{H}_5\text{Mn}_4\text{Al}_4\text{VSi}_4\text{O}_{23}$?; Yellow to yellowish brown; Resinous; Cl. pinacoidal; H. 6-7; G. 3.65; F. 2-2; IV.

C. *The solution is colorless or nearly so.*

1. Fusibility below 5.

a. Gelatinizes with HCl.

— Yields no water.

TEPHROITE, Mn_2SiO_4 ; Smoky-gray to brownish red; Cl. pinacoidal; H. 5.5-6; G. 4.04; F. 3.5; IV.

Glaucochroite, CaMnSiO_4 ; Blue, green; H. 6; G. 3.40; F. 3.5; IV.

The HNO_3 solution yield a precipitate with silver nitrate (chlorine).

Eudialyte, Si, Al, Ca, Na, K, O, Cl, $(\text{SO}_4)(\text{CO}_3)$?;

- Rose to brown; Cl. basal; H. 5-5.5; G. 2.92; F. 3; III.
- + . Yields water.
- Ganophyllite**, $Mn_7(AlO)_2(SiO_3)_8.6 H_2O$; Brown; Cl. basal; H. 4-4.5; G. 2.84; F. 3; V; Foliated. Dissolves in HCl, liberating hydrogen sulphide.
- Helvite**, $(Mn.Fe)_2(Mn_2S)Be_3(S:O_4)_3$; Yellow, brown, green, red; H. 6-6.5; G. 3.20; F. 4-4.5; I.
- b. Decomposed in HCl without gelatinizing.
- + . Yields water.
- Friedelite**, $H_7(MnCl)Mn_4(SiO_4)_4$; Rose-red; Cl. basal; H. 4.5; G. 3.07; F. 4; III.
- Bementite**, H_2MnSiO_4 ; Pale grayish yellow; Cl. basal; H. 2.5-3; G. 2.98; F. 3.5; Foliated.
- Inesite**, $(Mn.Ca)_2(SiO_3)_2.H_2O$; Rose- to flesh-red; Cl. pinacoidal; H. 6; G. 3.03; F. 3; VI.
- . Yields no water.
- Trimerite**, $Be(Mn.Ca.Fe)SiO_4$; White to salmon-pink; Cl. basal; H. 6-7; G. 3.47; F. 4-5?; VI. Dissolves in HCl yielding hydrogen sulphide.
- ALABANDITE**, MnS ; Iron- to greenish-black; H. 3.5-4; G. 3.95; F. 3; I; p. 304.
- c. Insoluble in HCl.
- + . Yields water.
- Piedmontite**, $Ca_2(Al.OH)_2(Al.Mn.Fe)_2(SiO_4)_3$; Reddish brown; Cl. basal; H. 6.5; G. 3.5; F. 3; V; p. 467.
- Carpholite**, $Mn(Al.2 OH)_2(SiO_3)_2$; Straw- to wax-yellow; Silky; H. 5-5.5; G. 2.93; F. 3; V; Fibrous.
- . Yields no water.
- Neptunite**, $(Na.K)(Fe.Mn)TiSi_4O_{12}$; Black; Cl. prismatic; H. 5-6; G. 3.23; F. 3.5; V.
- SPESSARTITE**, $Mn_3Al_2(SiO_4)_3$; Brownish to garnet-red; H. 7-7.5; G. 4.2; F. 3; I; p. 444.
- Partschinite**, $(Mn.Fe)_3Al_2(SiO_4)_3$; Yellowish red; Greasy; H. 6.5-7; G. 4.00; F. 3; V.
- RHODONITE**, $MnSiO_3$; Rose-red, pink, brown; Cl. prismatic; H. 6-6.5; G. 3.63; F. 3.5; VI; p. 430.
- Schefferite**, $(Ca.Mn)(Mg.Fe)(SiO_3)_2$; Yellowish to reddish brown; Cl. prismatic; H. 5-6; G. 3.5; F. 4; V.

Richterite, $(\text{Mg.Mn.Ca.Na}_2)_4(\text{SiO}_3)_4$; Brown, yellow, rose-red; Cl. prismatic; H. 5.5-6; G. 3.09; F. 4; V.

2. Fusibility above 5.

a. Effervesces with warm dilute HCl (carbonates).

RHODOCROSITE, MnCO_3 ; Rose to dark red, brown; Cl. rhombohedral; H. 2.5-4.5; G. 3.52; III; p. 390.

Torrensit, $\text{MnSiO}_3.\text{MnCO}_3.\frac{1}{2}\text{H}_2\text{O}$; Reddish gray; Compact.

b. Do not effervesce in HCl.

+. Yields water.

WAD, Impure oxides of manganese; Gray, brown, black; Dull; Massive; Earthy; p. 368.

Pyrochroite, $\text{Mn}(\text{OH})_2$; White to bronze; Pearly; Cl. basal; H. 2.5; G. 3.26; III.

-. Yields no water.

Manganosite, MnO ; Dark emerald-green; Cl. cubic; H. 5-6; G. 5.18; I.

XI. The mineral, well powdered, is dissolved in considerable quantities in the borax bead on wire. The bead is then powdered and dissolved in 1 cc. strong HCl; to the hot solution powdered tin is added.

A. *The solution is violet (titanium). If the solution is poured off the tin and a few drops of hydrogen peroxide added, it becomes a deep orange or yellow according to the quantity of titanium present.*

1. Gelatinizes with HCl. Fusibility below 5.

a. Fuses quietly.

Schorlomite, $\text{Ca}_3(\text{Fe.Ti.Al})_2[(\text{Si.Ti})\text{O}_4]_3$; Black; H. 7-7.5; G. 3.88; F. 4; I.

b. Fuses with intumescence.

Tscheffkinite, Si, Ti, Th, Ce, Fe, Ca, O?; Velvet-black; H. 5-5.5; G. 4.55; F. 4; Massive.

Rinkite, $\text{Na}_2, \text{Ca}_{11}, (\text{Ti.F}_2)_4(\text{SiO}_4)_{12}$; Straw-yellow, yellowish brown; Cl. pinacoidal; H. 5; G. 3.46; V.

2. Do not gelatinize with HCl.

a. Fusibility below 5.

TITANITE, CaTiSiO_3 ; Gray, brown, green, yellow, black; Cl. prismatic; H. 5-5.5; G. 3.5; F. 4; V; p. 503.

Guarinite, CaTiSiO_5 ; Sulphur- to honey-yellow; Cl. pinacoidal; H. 6; G. 3.5; F. 4; IV.

Keilhauite, $\text{CaTiSiO}_5(\text{Y.Al.Fe})_2\text{SiO}_5$; Brownish black; Cl. prismatic; H. 6.5; G. 3.65; F. 4-4.5; V.

Neptunite, $(\text{Na.K})(\text{Fe.Mn})\text{TiSi}_4\text{O}_{12}$; Black; Cl. prismatic; H. 5-6; G. 3.23; F. 3.5; V.

Benitoite, BaTiSiO_5 ; Colorless, blue; H.6.5; G. 3.64; III.

Mosandrite, $\text{H}_{12}\text{Na}_2, \text{Ce}_2, \text{Ca}_{10}[(\text{Ti.Zr})(\text{OH.F})_2]_4(\text{SiO}_4)_{12}$; Reddish to greenish brown; Resinous; Cl. one; H. 4; G. 2.96; Compact.

b. Fusibility above 5.

PEROVSKITE, CaTiO_3 ; Yellow, orange, brown, black; Cl. cubic; H. 5.5; G. 4.93; I; p. 347.

RUTILE, TiO_2 ; Yellow, reddish brown to black; Cl. prismatic; H. 6-6.5; G. 4.22; Int.; II; p. 349.

OCTAHEDRITE, TiO_2 ; Yellow, brown, blue, black; Cl. basal and pyramidal; H. 5.5-6; G. 3.88; II; p. 351.

BROOKITE, TiO_2 ; Hair-brown to black; H. 6; G. 3.94; IV; p. 351.

Zirkelite, $(\text{Ca.Fe.UO}_2)(\text{Zn.Ti})_2\text{O}_5$; Black; Resinous; H. 5; G. 4.71; I.

XII. The solution is blue (tungsten) or (columbium). Fusibility above 5.

1. The solution first assumes a violet color and then becomes blue.

Æschynite, Cb, Ti, Th, Ce, La, Ca, Fe, O?; Brownish black to black; Resinous; H. 6.5; G. 4.93; Inf.; IV.

Euxenite, Cb, Ti, Y, Er, Ce, U, Fe, H, O, ?; Brownish black to black; Resinous; H. 6; G. 5.00; IV.

Polycrase, Cb, Ti, Y, Er, Ce, U, Fe, H, O, ?; Brownish black to black; H. 6; G. 5.00.

Pyrochlore, Cb, Ti, Ca, Na, O, Th, Ce, Fe, F?; Brownish black to black; H. 5-5.5; G. 4.28; I.

2. The solution is blue without passing through violet.

SCHEELITE, CaWO_4 ; White, yellow, green, brown; Cl. pyramidal; H. 4.5-5; G. 6.05; II; p. 543.

Tungstite, WO_3 ; Yellow, greenish yellow; dull; IV; Earthy.

Hatchettolite, Cb, Ta, U, Ca, O, H, Fe ?; Yellowish brown; Resinous; H. 5; G. 4.85; I.

Microlite, Ta, Cb, Ca, Na, C, F, H ? ; Pale yellow to brown ; Resinous ; H. 5.5 ; G. 5.5 ; I.

FERGUSONITE, (Y.Er.Ce)(Cb.Ta)O₄ ; Brownish black ; Resinous ; H. 5.5-6 ; G. 5.80 ; II ; Massive.

Sipylite, (Er.Ce.La.Di.H₃)CbO₄, ? ; Brownish black ; Resinous ; H. 6 ; G. 4.9 ; II ; Massive.

Compare, Columbite p. 634.

Wohlerite, Si, Zr, Cb, Ca, Na, O, ? ; Straw to brownish yellow ; Cl. pinacoidal ; H. 5.5-6 ; G. 3.44 ; F. 3-3.5 ; V.

XIII. The mineral in powder is dissolved in the S. Ph. bead.

A. *The S. Ph. bead in R. F. is yellow (nickel).*

1. Effervesces in hot dilute HCl (carbonates).

Zaraitite, (Ni.OH)₂CO₃.Ni(OH)₂.4 H₂O ; Emerald-green ; H. 3 ; G. 2.63 ; F. Inf. ; Massive.

2. Do not effervesce with HCl.

GENTHITE, H₄Ni₂Mg₂(SiO₄)₃.4 H₂O ; Pale to deep-green ; Dull ; H. 3-4 ; G. 2.41 ; Inf. ; Amorph. ; p. 500.

Morenosite, NiSO₄.7 H₂O ; Apple-green, greenish white ; Cl. pinacoidal ; H. 2 ; G. 2.00 ; IV.

B. *The S. Ph. bead is blue in both flames (cobalt).*

1. Effervesces with HCl.

Sphærocobaltite, CoCO₃ ; Rose-red ; H. 4 ; G. 4.07 ; Inf. ; III.

Remingtonite, CoCO₃, + H₂O ; Rose-red ; Soft ; Earthy ; Yields water.

C. *The S. Ph. bead is green in R. F. when cold (chromium or uranium).*

1. Shows chromium ; § b, p. 569.

UVAROVITE, Ca₃Cr₂(SiO₄)₃ ; Emerald-green ; H. 7.5 ; G. 3.42 ; Inf. ; I ; p. 445.

Fuchsite, H₂K(Al.Cr)₃(SiO₄)₃ ; Emerald-green ; Cl. basal ; H. 2.5 ; G. 2.86 ; F. 5 ; V ; Micaceous.

Kämmererite, H₈Mg₅(Al.Cr)₂Si₃O₁₈ ; Garnet to peach-blossom-red ; Cl. micaceous ; H. 2-2.5 ; G. 2.75 ; F. 5 ; V.

2. Shows uranium ; § b, p. 576.

Uranophane, CaU₂Si₂O₁₁.5 H₂O ; Honey-, lemon-, or straw-yellow ; H. 2-3 ; G. 3.86 ; Inf. ; VI.

Uranophilite, CaU₈S₂O₃₁.25 H₂O ; Yellow ; G. 3.75 ; Velvety, incrusted ; Inf.

- a. Yields a reaction for vanadium (§ *b*, p. 576), as well as for uranium.

Carnotite, $K_2(UO_2)_2(VO_4)_2 \cdot 3 H_2O$; Yellow; Dull; H. 2.5; F. 3; Earthy.

3. Shows vanadium; § *b*, p. 576.

Roscoelite, $H_8K_2(Mg,Fe)(Al,V)_4(SiO_3)_{12}?$; Clove-brown to brown-green; Pearly; Cl. basal; H. 2?; G. 2.93; F. 3.

4. Shows molybdenum; § *b*, p. 586.

- a. The concentrated HCl solution yields a white precipitate with H_2SO_4 .

Powellite, $CaMoO_4$; Colorless, green, yellow; Resinous; H. 3.5; G. 4.52; F. 4; II.

- b. Yields no precipitate with H_2SO_4 .

Belonesite, $MgMoO_4$; White; F. 4-5; II.

- XIV. Minerals not included in the preceding groups. They are classified according to their fusibility, solubility in acids, and hardness.

A. *Fusibility below 5.*

1. Hardness below 5.

+ Yields water.

- a. Soluble in HCl or decomposed with the separation of silica.

a. Fuses with intumescence or exfoliates.

VERMICULITE, Si, Al, Mg, O, (H_2O), ?; Yellow, brown, light to dark green; Pearly; Cl. basal; H. 1.5; G. 4-4.5; F. 4.5.

The dilute HCl solution yields a precipitate with H_2SO_4 (barium).

HARMOTOME, $(Ba,K_2)Al_2Si_5O_{14.5} H_2O$; White; Cl. pinacoidal; H. 4.5; G. 2.47; F. 3; V; p. 482.

Brewsterite, $H_4(Sr,Ba,Ca)Al_2(SiO_3)_6 \cdot 3 H_2O$; White, yellow, gray; Cl. pinacoidal; H. 5; G. 2.45; F. 3; V.

Wellsite, $(Ca,K_2,Ba)Al_2Si_3O_{10} \cdot 3 H_2O$; White; H. 4-4.5; G. 2.32; F. 3; V.

The dilute HCl solution yields no precipitate with H_2SO_4 .

HEULANDITE, $H_4(Ca,Na_2)Al_2(SiO_3)_6 \cdot 3 H_2O$; White, yellow, red; Pearly, Cl. pinacoidal; H. 3.5-4; G. 2.20; F. 3; V; p. 481.

STILBITE, $H_4(Ca,Na_2)Al_2(SiO_3)_6 \cdot 4 H_2O$; White, yellow,

low, brown, red; Pearly; Cl. pinacoidal; H. 3.5-4; G. 2.36; F. 3; V; p. 483.

Gmelinite, $(\text{Na}_2.\text{Ca})\text{Al}_2(\text{SiO}_3)_{4.6}\text{H}_2\text{O}$; White, yellow, flesh-red; Cl. prismatic; H. 4.5; G. 2.10; F. 3; III; Rhombohedral.

Epistilbite, $\text{H}_4(\text{Ca}.\text{Na}_2)\text{Al}_2(\text{SiO}_3)_{6.3}\text{H}_2\text{O}$; White; Cl. pinacoidal; H. 4-4.5; G. 2.25; V.

β . Fuses quietly.

DEWEYLITE, $\text{H}_4\text{Mg}_4(\text{SiO}_4)_{3.4}\text{H}_2\text{O}$; Yellow, brown, apple-green, resinous; H. 2.5-4; G. 2.40; F. 4-5; Amorphous.

b. Gelatinizes in HCl.

α . Shows calcium; § b, p. 566.

Gyrolite, $\text{H}_2\text{Ca}_2(\text{SiO}_3)_3.\text{H}_2\text{O}$; White; H. 3.4; F. 3; Radiated.

Okenite, $\text{H}_2\text{Ca}(\text{SiO}_3)_2.\text{H}_2\text{O}$; White, cream, bluish white; Dull; H. 4.5-5; G. 2.28; F. 2.5-3; Fibrous, compact.

β . Becomes blue with cobalt solution.

LAUMONTITE, $(\text{Ca}, (\text{Al}.2\text{OH})_2(\text{Si}_2\text{O}_5)_2\text{H}_2\text{O}$; White to gray; H. 3.5-4; G. 2.30; F. 2.5; V; p. 479.

Gismondite, $(\text{Ca}.\text{K}_2)\text{Al}_2(\text{SiO}_3)_{4.4}\text{H}_2\text{O}$; White; H. 4.5; G. 2.26; F. 3; V.

Levynite, $\text{CaAl}(\text{Al}.2\text{OH})(\text{SiO}_3)_{3.4}\text{H}_2\text{O}$; White, gray red; H. 4.5; G. 2.13; F. 2.5; III.

γ . The dilute HCl solution yields a precipitate with H_2SO_4 (barium).

Edingtonite, $\text{BaAl}(\text{Al}.2\text{OH})(\text{SiO}_3)_{3.2}\text{H}_2\text{O}$; White, pink; Cl. prismatic; H. 4.5-5; G. 2.77; F. 2.5; IV.

δ . Shows magnesium with cobalt solution; p. 567.

Spadaite, $\text{H}_2\text{Mg}_5(\text{SiO}_3)_{6.3}\text{H}_2\text{O}$; Flesh-red; Pearly; H. 2.5; F. 4; Massive.

c. Not soluble or decomposed in HCl.

α . Yields a red flame with lithium flux (lithium).

LEPIDOLITE, $\text{LiKAl}(\text{OH}.\text{F})_2\text{Al}(\text{SiO}_3)_3$; Lilac, grayish white; Pearly; Cl. Basal; H. 2.5-4; G. 2.85; 2; V; p. 495.

Cookeite, $\text{Li}(\text{Al}.2\text{OH})_3(\text{SiO}_3)_2$; White; Pearly; Cl. basal; H. 2.5; G. 2.65; F. 4; V.

β . Decomposed with hot concentrated H_2SO_4 ; all micaceous.

*. Shows potassium.

BIOTITE, $(K.H)_2(Mg.Fe)_2(Al.Fe_2)(SiO_4)_3$; Green, yellow, black; Cl. basal; H. 2.5; G. 2.90; F. 5; V; p. 492.

PHLOGOPITE, $(H.K)_3(Mg.Fe)_3(Al.Fe)(SiO_4)_3$; Yellowish brown, green, white; H. 2.5-3; G. 2.86; F. 4.5-5; V; p. 494.

** Shows no potassium.

CLINOCHLORE, $H_3Mg_5Al_2Si_3O_{18}$; Green of various shades; H. 2.2; G. 2.72; F. 5; V; p. 497.

γ. Not decomposed with H_2SO_4 .

* Yields a potassium flame through the blue glass; Micaceous.

MUSCOVITE, $H_2KAl_3(SiO_4)_3$; White, brown, green, yellow; H. 2-2.5; G. 2.86; F. 4.5-5; V; p. 489.

Alurgite, $H(K.Mg.OH)_2(Al.OH)Al(SiO_3)_4$; Rose-red to deep red; Pearly; H. 3; V.

Yields water; Not micaceous.

HARMOTOME, $(Ba.K_2)Al_2Si_5O_{14.5}H_2O$; White; Cl. pinacoidal; H. 4.5; G. 2.47; F. 3; V; p. 482.

Mordenite, $(K_2.Na_2.Ca)Al_2Si_{10}O_{24}.6\frac{2}{3}H_2O$; White, yellow, pink; Cl. pinacoidal; H. 3-4; G. 2.15; F. 4-5; V.

** Shows no potassium.

Paragonite, $H_2NaAl_3(SiO_4)_3$; Yellow to grayish white; Pearly; H. 2.5-3; G. 2.89; F. 5; V.

MARGARITE, $H_2CaAl_4Si_2O_{12}$; Pink, gray, white; Pearly; H. 3.5-4; G. 3.05; F. 4-4.5; V; p. 496.

- Yields no water.

Leucophanite, $Na(BeF)Ca(SiO_3)_2$; Pale green, yellow, white; Cl. basal; H. 4; G. 2.96; F. 2.5-3; IV.

2. Hardness above 5.

+ Yields water in the closed tube, some only upon intense ignition.

a. Decomposed or soluble in HCl.

α. Fuses with swelling or intumescence.

CHABAZITE, $(Ca.Na_2)Al_2(SiO_3)_4.6H_2O$; White, yellow, red; Cl. rhombohedral; H. 5; G. 2.12; F. 3; III; p. 484.

APOPHYLLITE, $H_7KC_4(SiO_3)_8.4\frac{1}{2}H_2O$; White, yellow, rose, pale green; H. 5; Cl. basal; Pearly; G. 2.35; F. 2; II. p. 480.

Brewsterite, $H_4(Sr.Ba.Ca)Al_2(SiO_2)_6 \cdot 3 H_2O$; White, yellow, red; Cl. pinacoidal; H. 5; G. 2.45; F. 3; V; Shows barium.

Phillipsite, $(Ca.K_2.Na_2)Al_2Si_4O_{12} \cdot 4 H_2O$; White; Cl. pinacoidal; H. 5; G. 2.20; F. 3; V.

Faujasite, $H_2(Ca.Na_2)Al_2(SiO_3)_5 \cdot 9 H_2O$; White, brown; Cl. octahedral; H. 5; G. 1.92; F. 3; I.

β. Fuses quietly.

PECTOLITE, $HNaCa_2(SiO_3)_3$; White, gray; Cl. pinacoidal; H. 5; G. 2.73; F. 2.5-3; V; p. 427.

ANALCITE, $NaAl(SiO_3)_2 \cdot H_2O$; White; H. 5-5.5; G. 2.27; F. 3.51; p. 485.

Catapleiite, $H_4(Na_2.Ca)ZrSi_3O_{11}$; Yellow, brown, gray, violet; Cl. prismatic; H. 6; G. 6.28; F. 2.5; III; Shows Zr.; § *a*, p. 571.

b. Gelatinizes with HCl.

α. Effervesces with HCl.

CANCRINITE, $H_6(Na_2.Ca)_4(Al.NaCO_3)_2Al_6(SiO_4)_9$; Yellow, pink, gray, white; Cl. prismatic; H. 5-6; G. 2.45; F. 2.5; III; p. 441.

Cenosite, Si, Y, Ca, O, $CO_3 \cdot H_2O$, ?; Yellowish brown; Greasy; Cl. pinacoidal; H. 5-5.5; G. 3.41; IV.

β. The HCl solution yields a precipitate showing the presence of aluminium, but not calcium, § *b*, p. 568.

NATROLITE, $Na_2Al_3(AlO)(SiO_3)_3 \cdot 2 H_2O$; White; Cl. prismatic; H. 5-5.5; G. 2.25; F. 2.5; IV; p. 486.

Hydronephelite, $HNa_2Al(SiO_3)_3 \cdot 3 H_2O$; White to dark gray; H. 5-6; G. 2.30; F. 2.5; III.

γ. Shows both aluminium and calcium.

SCOLECITE, $CaAl(Al \cdot 2 HO)(SiO_3)_3 \cdot 2 H_2O$; White; Cl. prismatic; H. 5-5.5; G. 2.30; F. 2.5; V; p. 479.

MESOLITE, $Na_2Ca_2Al_6Si_9O_{30} \cdot 8 H_2O$; White, gray, yellow; Cl. prismatic; H. 5; G. 2.29; F. 2.5; V; p. 478.

THOMSONITE, $(Ca.Na_2)Al_2(SiO_4)_2 \cdot 2\frac{1}{2} H_2O$; White, gray; Cl. pinacoidal; H. 5-5.5; G. 2.35; F. 2.5; IV; p. 487.

δ. Shows calcium but no aluminium; § *b*, p. 566.

Okenite, $H_2Ca(SiO_3)_2 \cdot H_2O$; White, cream, bluish white; Dull; H. 4.5-5; F. 3; Fibrous, compact.

c. Insoluble or not decomposed in HCl.

α . In the forceps yields a yellow flame (sodium).

Epididymite, $\text{HNaBeSi}_3\text{O}_8$; White; Cl. basal; H. 6; G. 2.55; F. 2.5–3; IV.

Eudidymite, $\text{HNaBeSi}_3\text{O}_8$; White; Cl. basal; H. 6; G. 2.55; F. 2.5–3; V; Tabular.

β . Does not yield a strong sodium flame.

EPIDOTE, $\text{Ca}_2(\text{Al.OH})(\text{Al.Fe})_2(\text{SiO}_4)_3$; Yellowish to blackish green, gray; Cl. basal; H. 6–7; G. 3.40; F. 3–4; V; p. 466.

ZOISITE, $\text{Ca}_2(\text{Al.OH})\text{Al}_2(\text{SiO}_4)_3$; Grayish white, pink, green; Cl. pinacoidal; H. 6–6.5; G. 3.26; F. 3–4; IV; p. 465.

Clinozoisite, $\text{Ca}_2(\text{Al.OH})\text{Al}_2(\text{SiO}_4)_3$; White to pale pink; Cl. basal; H. 6–7; G. 3.37; F. 3–4; V.

Lawsonite, $\text{Ca}(\text{Al.2 OH})(\text{SiO}_4)_3$; Grayish blue to white; Cl. pinacoidal; H. 8; G. 3.09; F. 4; IV.

–. Yields no water in the closed tube.

a. Decomposed in HCl with separation of silica, but without gelatinizing.

LABRADORITE, $\text{CaAlSi}_3\text{O}_8$; White, gray; Cl. basal and pinacoidal; H. 6; G. 2.73; F. 4; VI; p. 416.

WERNERITE, $\text{Ca}_4\text{Al}_6\text{Si}_6\text{O}_{25}\text{Na}_4\text{Al}_3\text{Si}_9\text{O}_{24}\text{Cl}$.; White, gray, light green; Cl. prismatic; H. 5.6; G. 2.68; F. 3; II; p. 453.

b. Gelatinizes with HCl.

α . Yields a sulphur reaction with soda and a sodium flame in the forceps.

LAZURITE, $(\text{Na}_2.\text{Ca})_2(\text{Al.Na.S}_3)\text{Al}_2(\text{SiO}_4)_3$; Deep azure to greenish blue; H. 5–5.5; G. 2.42; F. 3.5; I; p. 438.

NOSELITE, $\text{Na}_4(\text{Al.NaSO}_4)\text{Al}_2(\text{SiO}_4)_3$; Gray, green, blue, brown; H. 5.5; G. 2.32; F. 3.5–4; I; p. 438.

HAÜYNITE, $(\text{Ca.Na}_2)_2(\text{Al.NaSO}_4)\text{Al}_2(\text{SiO}_4)_3$; Blue, green, yellow, white; H. 5.5–6; G. 2.45; F. 4; I; p. 438.

Microsommite, Si, Al, Ca, Na, K, O, Cl, (SO_4) , (CO_3) , ?; White; Cl. prismatic; H. 6; G. 2.44; F. 3.5; III.

β . Shows aluminium, § b, p. 568.

*. Shows chlorine; § a, p. 588. Yields a sodium flame in the forceps.

SODALITE, $\text{Na}_4(\text{AlCl})\text{Al}_2(\text{SiO}_4)_3$; White, gray, blue, green; H. 5.5-6; G. 2.30; F. 3.5; I; p. 438.

** Yields a strong sodium flame, but no chlorine.

NEPHELITE, $(\text{Na}_2.\text{K}_2.\text{Ca})_4\text{Al}_3\text{Si}_9\text{O}_{34}$; White, gray, greenish, reddish; Cl. prismatic; H. 5.5-6; G. 2.60; F. 4; III; p. 440.

*** Yields calcium; § *b*, p. 566.

ANORTHITE, $\text{CaAl}_2(\text{SiO}_4)_2$; White, gray; Cl. basal and pinacoidal; H. 6-6.5; G. 2.75; F. 4.5; VI; p. 413.

MELILITE, Si, Al, Fe, Ca, Mg, Na, O?; Green, yellow, brown, white; Cl. basal; H. 5; G. 3.00; F. 4; II; p. 451.

Sarcolite, $(\text{Ca}.\text{Na}_2)_3\text{Al}_2(\text{SiO}_4)_3$; Flesh to rose-red, white; H. 6; G. 2.7; F. 3; II.

γ. Contains no aluminium.

* Shows calcium, § *b*, p. 566.

WOLLASTONITE, CaSiO_3 ; White, gray; Cl. pinacoidal; H. 5-5.5; G. 2.85; F. 4; V; p. 429.

** Shows zirconium; § *a*, p. 571.

Hiortdahlite, $(\text{Na}_2.\text{Ca})(\text{Si}.\text{Zr})\text{O}_3?$; Straw-yellow to yellowish brown; H. 5.5-6; G. 3.26; F. 3; VI.

c. Insoluble in HCl.

α. Yields a red flame in the forceps (lithium).

SPODUMENE, $(\text{Li}.\text{Na})\text{Al}(\text{SiO}_3)_2$; White, gray, pink, green; Cl. prismatic; H. 6.5-7; G. 3.18; F. 3.5; V; p. 426.

PETALITE, $(\text{Li}.\text{Na})\text{Al}(\text{Si}_2\text{O}_5)_2$; White, gray, pink; Cl. basal; H. 6-6.5; G. 2.40; F. 4; V; p. 426.

β. Yields a potassium flame through the blue glass when fused with potassium flux; § *a*, p. 563.

ORTHOCLASE, KAlSi_3O_8 ; White, gray, cream, flesh-red, green; Cl. basal and pinacoidal; H. 6; G. 2.57; F. 5; V; p. 403.

MICROCLINE, Same, but VI, p. 409.

Yields a little water in the closed tube at a high temperature.

Milarite, $\text{HKCa}_2\text{Al}_2(\text{Si}_2\text{O}_5)_6$; White to pale green; H. 5.5-6; G. 2.55; F. 3; III

γ. Yields a strong sodium flame in the forceps.

ALBITE, $\text{NaAlSi}_3\text{O}_8$; White to gray; Cl. basal and pinacoidal; H. 6; G. 2.62; F. 4; VI; p. 411.

See p. 403 for intermediate feldspars which may be of various colors.

JADEITE, $\text{NaAlSi}_2\text{O}_6$; White, grayish green; Cl. prismatic; H. 7; G. 3.33; F. 2.5; V; p. 426.

Glaucophane, $\text{Na}_2\text{Al}_2(\text{SiO}_3)_4.\text{Mg}_4(\text{SiO}_3)_4$; Lavender to azure-blue; Cl. prismatic; H. 6-6.5; G. 3.11; F. 3-4.

Epididymite, $\text{HNaBeSi}_3\text{O}_8$; White; Cl. basal; H. 6; G. 2.55; F. 2.5-3; IV.

Eudidymite, $\text{HNaBeSi}_3\text{O}_8$; White; Pearly; Cl. basal; H. 6; G. 2.55; F. 2.5-3; V; Tabular.

Shows chlorine, § 587.

WERNERITE, $\text{Ca}_4\text{Al}_6\text{Si}_6\text{O}_{25}.\text{Na}_4\text{Al}_2\text{Si}_9\text{O}_{24}\text{Cl}$; White, gray, light green; Cl. prismatic; 2.5-6; G. 2.68; F. 3; II; p. 453.

Marialite, $\text{Na}_4\text{Al}_3\text{Si}_9\text{O}_{24}\text{Cl}$; White; H. 5.5-6; G. 2.56; F. 3-4; II.

δ. Yields test for aluminium and calcium; § b, p. 566.

*. Fuses quietly.

ANORTHITE, $\text{CaAl}_2(\text{SiO}_4)_2$; White to gray; Cl. basal and pinacoidal; H. 6; G. 2.75; F. 4.5; VI; p. 413.

GROSSULARITE, $\text{Ca}_3\text{Al}_2(\text{SiO}_4)_3$; Pale red, yellow, green, white; H. 6.5-7.5; G. 3.50; F. 3; I; p. 443.

HORNBLLENDE, Complex silicate; Green to black; Cl. prismatic; H. 6; G. 3.15; F. 3-4; V; p. 431.

AUGITE, Complex silicate; Greenish black to black; Cl. prismatic; H. 5.7; G. 3.30; F. 4-4.5; V; p. 418.

** Fuses with intumescence.

PREHNITE, $\text{H}_2\text{Ca}_2\text{Al}_2(\text{SiO}_4)_3$; Apple-green, gray, white; H. 6-6.5; G. 2.9; F. 2.5; IV; p. 470.

VESUVIANITE, Complex silicate; H. 6.5; G. 3.40; F. 3; II; p. 455.

EPIDOTE, $\text{Ca}_2(\text{AlOH})(\text{Al.Fe})_2(\text{SiO}_4)_3$; Yellowish to blackish green, gray; Cl. basal; H. 6-7; p. 466.

ZOISITE, $\text{Ca}_2(\text{AlOH})\text{Al}_2(\text{SiO}_4)_3$; Grayish white, green, pink; Cl. pinacoidal; H. 6-6.5; G. 3.26; F. 3-4; V; p. 465.

Clinzoisite, $\text{Ca}_2(\text{AlOH})_2(\text{Al})(\text{SiO}_4)_3$; White to pale pink; Cl. basal; H. 6-7; G. 3.37; F. 3-4; V; p. 465.

e. Shows aluminium and magnesium, but little or no calcium; § *b*, p. 567.

PYROPE, $Mg_3Al_2(SiO_4)_3$; deep red; H. 6.5–7.5; G. 3.72; F. 3.5–4; I; p. 443.

ζ. Shows calcium and magnesium, but little or no aluminium; § *b*, p. 567.

TREMOLITE, $CaMg_3(SiO_3)_4$; White, gray, violet; Cl. prismatic; H. 5–6; G. 3.00; F. 4; V; p. 431.

DIOPSIDE, $CaMg(SiO_3)_2$; White to pale green; H. 5–6; G. 3.29; F. 4; V; p. 423.

PYROXENE, $Ca(Mg.Fe)(SiO_3)_2$; Light to dark green; Cl. prismatic; H. 5–6; G. 3.3; F. 4; V; p. 419.

ACTINOLITE, $Ca(Mg.Fe)_3(SiO_3)_4$; Various shades of green; Cl. prismatic; H. 5–6; G. 3.10; F. 4; V; p. 431.

η. Shows magnesium and iron, but little or no calcium, § *b*, p. 567.

ANTHOPHYLLITE, $(Mg.Fe)SiO_3$; Gray, clove-brown to green; Cl. prismatic; H. 5.5–6; G. 3.10; IV.

ENSTATITE, $(Mg.Fe)SiO_3$; Gray-brown to green; Pearly, bronze-like; Cl. pinacoidal; H. 5.5–6.5; G. 3.20; F. 5–6; IV; p. 421.

θ. Shows magnesium, but no silica. Reacts for fluorine; § *a*, p. 589.

Sellaite, MgF_2 ; White; Cl. basal; H. 5; G. 3.06; F. 4–5; II.

B. Fusibility above 5.

1. Hardness below 5.

+ . Yields water.

a. Soluble in HCl, or decomposed with the separation of silica.

α. Yields a sulphur reaction with soda.

ALUMINITE, $Al_2(OH)_4SO_4 \cdot 7 H_2O$; White; Dull; H. 1–2; G. 1.66; V; p. 542.

Felsöbanyite, $Al_2(OH)_4SO_4 \cdot 2 Al(OH)_3 \cdot 5 H_2O$; White to pearly; Cl. perfect; H. 1.5; G. 2.33; III; Scaly.

Alumian, $(Al_2O)(SO_4)_2$; White; H. 2–3; G. 2.7; III; Massive; Yields no water.

Yields a violet flame (potassium).

Löwigite, $K(Al_2 OH)_3(SO_4)_2 \cdot 1\frac{1}{2} H_2O$; Straw-yellow; H. 3–4; G. 2.58; Massive.

β . Yields a fluorine reaction.

Fluocerite, $(\text{Ca.La.Di})_2\text{OF}_4\cdot\text{OH}$; Reddish yellow; Cl. two directions; H. 4; G. 5.80; Massive; III.

Yttrocerite, $(\text{Y.Er.Ce})\text{F}_3\cdot 5\text{CaF}_2\cdot\text{H}_2\text{O}$; Violet, gray, brown, white; Greasy; H. 2.5-3; G. 3.45; Massive.

γ . Ignited with cobalt solution becomes flesh-pink (magnesium).

DEWEYLITE, $\text{H}_4\text{Mg}_4(\text{SiO}_4)_3\cdot 4\text{H}_2\text{O}$; Yellow to apple-green; Resinous; H. 3-4; G. 2.40; Amorphous.

Sepiolite, $\text{H}_4\text{Mg}_2\text{Si}_3\text{O}_{10}$; White to grayish white; Dull; H. 2-2.5; G. 2.0; Compact.

Usually too dark in color to show pink with cobalt solution.

SERPENTINE, $\text{H}_4(\text{Mg.Fe})_3\text{Si}_2\text{O}_9$; Olive, blackish, or yellowish green, white; Greasy; H. 2.5-6; G. 2.56; Massive; p. 498.

b. Gelatinizes with HCl.

ALLOPHANE, $\text{Al}_2\text{SiO}_5\cdot\text{H}_2\text{O}$; White, yellow, green, blue; H. 3; G. 1.88; Amorphous, p. 502.

c. Insoluble in HCl.

α . Micaceous.

CLINOCHLORE, $\text{H}_8\text{Mg}_5\text{Al}_2\text{Si}_3\text{O}_{18}$; Green of various shades; H. 2-2.5; G. 2.75; V; p. 497.

Clintonite, $\text{H}_3(\text{Mg.Ca})_5\text{Al}_5\text{Si}_2\text{O}_8$; Reddish brown, copper-red; Pearly; H. 4-5; G. 2.87; V.

Xanthophyllite, $\text{H}_5(\text{Mg.Ca})_{14}\text{Al}_{16}\text{Si}_5\text{O}_{52}$; Light green; H. 4-5; G. 3.09; V.

Prochlorite, $\text{H}_{40}(\text{Fe.Mg})_{23}\text{Al}_{14}\text{Si}_{12}\text{O}_{90}$?; Green to blackish green; H. 1-2; G. 2.87; V.

β . Becomes blue with cobalt solution.

PYROPHYLLITE, $\text{H}_2\text{Al}_2(\text{SiO}_3)_4$; White, apple-green, gray, brown; Pearly; H. 1-2; G. 2.85; Foliated, compact; p. 502.

KAOLINITE, $\text{H}_4\text{Al}_2\text{Si}_2\text{O}_9$; White; Pearly, dull; Cl. basal; H. 2-2.5; G. 2.60; V; p. 501.

GIBBSITE, $\text{Al}(\text{OH})_3$; White; Pearly, dull; Cl. basal; H. 2.5-3.5; G. 2.35; V; p. 365.

BAUXITE, $\text{Al}_2\text{O}(\text{OH})_4$; White, gray, yellow, red; Dull, earthy; G. 2.55; Massive, clay-like; p. 366.

γ . Yields a sulphur reaction when fused with soda.

ALUNITE, $(K.Na)(Al_2OH)_3(SO_4)_2$; White, gray;
Cl. basal; H. 3.5-4; G. 2.85; III; p. 541.

δ. With potassium bisulphate yields a fluorine reaction; § a, p. 589.

Ralstonite, $(Na_2.Mg)F_2.3Al(F.OH)_3.2H_2O$; White to straw-yellow; H. 4.5; G. 2.59; I.

Prosopite, $Ca(F.OH)_2.2Al(F.OH)_3$; White, gray; H. 4.5; G. 2.89; V.

Fluellite, $AlF_3.H_2O$; White; H. 3; G. 2.17; IV.

ε. With cobalt solution becomes flesh-pink (magnesium).

TALC, $H_2Mg_3(SiO_3)_4$; Apple-green, gray, white; Pearly, greasy; Cl. basal; H. 1; G. 2.80; Foliated, compact; p. 500.

-. Yields no water.

a. Fused with potassium bisulphate yields a fluorine reaction.

Tysonite, $(Ce.La.Di)F_3$; Wax-yellow, reddish brown; Cl. basal; H. 4.5-5; G. 6.13; III.

Bastnäsite, $(Ce.La.Di.F)CO_3$; Wax-yellow, reddish brown; H. 4.5-5; G. 5.08; Massive.

2. Hardness above 5.

+. Yields water.

a. Soluble in HCl.

Pollucite, $H_2Cs_4Al_4(SiO_3)_9$; White; H. 5.5-6; G. 2.98; I; Massive.

b. Gelatinizes with HCl.

a. Fused with potassium bisulphate shows fluorine.

CHONDRODITE, $Mg_3[Mg(F.OH)]_2(SiO_4)_2$; Brownish red, yellow, white; Cl. basal; H. 6-6.5; G. 3.15; V; p. 471.

Humite, $Mg_5[Mg(F.OH)]_2(SiO_4)_3$; Brownish red, yellow, white; Cl. basal; H. 6-6.5; G. 3.15; IV.

Clinohumite, $Mg_7[Mg(F.OH)]_2(SiO_4)_4$; Brownish red, yellow, white; Cl. Basal; H. 6-6.5; G. 3.15; V.

Prolectite, $Mg[Mg(F.OH)]_2SiO_4$; Brownish gray; V.

β. Yields the rare earths; p. 572.
CERITE, $(Ca.Fe)(CeO)(Ce_2.3OH)(SiO_3)_3$; Clove-brown, gray, red; Dull, resinous; H. 5.5; G. 4.90; IV.

Thorite, $ThSiO_4$, Orange-yellow, brown, black; Resinous; Cl. prismatic; H. 5; G. 4.90; II.

- c. Insoluble in HCl or not decomposed.
- α. The finely powdered mineral when fused with one and one half parts of soda yields a bead remaining clear when cold.
- OPAL**, SiO_2 with water; White, colors of various shades; H. 5.5–6.5; G. 2.15; Amorphous; p. 369.
- β. Becomes blue with cobalt solution.
- DIASPORE**, $\text{AlO}(\text{OH})$; White, gray, yellowish, greenish; Cl. pinacoidal; H. 6.5–7; G. 3.40, IV; p. 365.
- Zunyite**, $[\text{Al}_2(\text{OH.F.Cl})]_6\text{Al}_2(\text{Si}_3\text{O}_7)_3$; White, gray; H. 7; G. 2.88; I.
- γ. May yield only a very small amount of water.
- STAUROLITE**, $(\text{AlO})_4(\text{Al.OH})\text{Fe}(\text{SO}_4)_2$; Red-brown to brownish black; Cl. pinacoidal; H. 7–7.5; G. 3.65; IV; p. 477.
- IOLITE**, $\text{H}_2(\text{Mg.Fe})_4\text{Al}_8\text{Si}_{10}\text{O}_{37}$; Light or dark blue, white; Cl. pinacoidal; H. 7–7.5; G. 2.61; IV; p. 440.
- δ. Shows berlium; p 571. Lavender with cobalt solution.
- Bertrandite**, $\text{Be}_2(\text{Be.OH})_2\text{Si}_2\text{O}_7$; White, yellow; Pearly; Cl. prismatic; H. 6–7; G. 2.60; IV.
- Euclase**, $\text{Be}(\text{Al.OH})\text{SiO}_4$; White to pale green; Pearly; Cl. pinacoidal; H. 7.5; G. 3.10; V.
- ε. Fused with soda yields a sulphur reaction.
- Melanophlogite**, $\text{SiO}_2\text{SO}_3\text{H}_2\text{O}$, etc. ?; White, light brown; H. 6.5–7; G. 2.02; I; Cubes.
2. Hardness above 5.
- Yields no water.
- a. Soluble or decomposed with HCl.
- α. Fused with potassium flux, shows potassium through the blue glass.
- LEUCITE**, $\text{KAl}(\text{SiO}_3)_2$; White, gray; H. 5.5–6; G. 2.47; I; p. 416.
- b. Gelatinizes with HCl.
- CHRYSOLITE**, $(\text{MgFe})\text{SiO}_4$; Olive to grayish green, brown; Cl. pinacoidal; H. 6.5–7; G. 3.33; IV; p. 446.
- α. Contains no iron.
- Forsterite**, Mg_2SiO_4 ; White, gray, yellowish; Cl. pinacoidal; H. 6.5–7; G. 3.24; IV; p. 450.

β . The concentrated HCl solution yields a precipitate with H_2SO_4 (calcium).

Gehlenite, $(Ca.Mg.Fe)_3Al_2Si_2O_{10}$; Grayish green, brown; H. 5.5-6; G. 2.98; F. 5; II.

γ . Yields a test for the rare earths.

GADOLINITE, $FeB_2Y_2Si_2O_{10}$; Black, greenish black, brown; H. 6.5-7; G. 4.25; V.

Thorite, $ThSiO_4$; Orange-yellow, brown, black; Resinous; Cl. prismatic; H. 5; G. 4.90; II.

c. Insoluble in HCl.

α . Yields a fine blue with cobalt solution.

CORUNDUM, Al_2O_3 ; All colors; Cl. rhombohedral; H. 9; G. 4.03; III; p. 341.

CYANITE, $Al(AlO)SiO_4$; Blue, gray, white, green; Cl. pinacoidal; H. 5-7; G. 3.62; VI; p. 461.

ANDALUSITE, $Al(AlO)SiO_4$; Flesh-red, reddish brown, olive; Cl. prismatic; H. 7.5; G. 3.18; IV; p. 459.

SILLIMANITE, $Al(AlO)SiO_4$; Brown, gray, greenish gray; Cl. pinacoidal; H. 6-7; G. 3.23; IV; p. 461.

Dumortierite, $Al_2(AlO)_6(SiO_4)_3$; Deep blue; Cl. pinacoidal; H. 7; G. 3.26; IV.

TOPAZ, $Al(Al(O.F_2))SiO_4$; White, yellow, pink, bluish, greenish; Cl. basal; H. 8; G. 3.53; IV; p. 458.

Kornerupine, $Mg(AlO)_2SiO_4$; White, yellowish brown; Cl. prismatic; H. 6.5; G. 3.27; IV.

CHRYSOBERYL, $BeAl_2O_4$; Yellowish to emerald-green; Cl. prismatic; H. 8.5; G. 3.67; IV; p. 377.

γ . Do not yield a fine blue with cobalt solution, some however may give a dull blue.

*. Fused with $1\frac{1}{2}$ parts of soda yields a bead remaining clear when cold.

QUARTZ, SiO_2 ; All colors; H. 7; G. 2.65; III; p. 352.

TRIDYMITE, SiO_2 ; White; H. 7; G. 2.30; III; p. 361.

CHALCEDONY, SiO_2 ; Various colors; Waxlike; H. 7; G. 2.62; Massive; p. 360.

** . Do not yield a clear bead.

Shows magnesium § c, p. 567.

ENSTATITE, $(Mg.Fe)SiO_3$; Gray, brown, green; Pearly, bronzelike; Cl. prismatic; H. 5.5-6.5; G. 3.20; IV; p. 421.

- HYPERSTHENE** $(\text{Mg.Fe})\text{SiO}_3$; Brownish green to greenish black; Pearly; Cl. pinacoidal; H. 5-6; G. 3.45; IV; p. 421.
- ANTHOPHYLLITE**, $(\text{Mg.Fe})\text{SiO}_3$; Gray, clove brown, green; Pearly; Cl. prismatic; H. 5.5-6; G. 3.10; IV.
- SPINEL**, $\text{Mg}(\text{AlO})_2$; Various colors; H. 8; G. 3.5-4; I; p. 371.
Yields a zirconium reaction § *a*, p. 571.
- ZIRCON**, ZrSiO_4 ; Brown, white, gray, green, red; Cl. prismatic; H. 7.5; G. 4.68; II; p. 456.
- Baddeleyite**, ZnO_2 ; White, yellow, brown, black; Cl. basal; H. 6.5; G. 5.5; V.
Shows beryllium, § *a*, p. 571.
- BERYL**, $\text{Be}_3\text{Al}_2(\text{Si}_3\text{O}_3)_{6.5}\text{H}_2\text{O}$; White, green, yellow, blue, pink; H. 7-7.5; G. 2.69; III; p. 436.
- PHENACITE**, Be_2SiO_4 ; White; Cl. prismatic; H. 7.5-8; G. 2.96; III; p. 452.
Powdered and reduced with soda yields magnetic particles.
- Hercynite**, $\text{Fe}(\text{AlO})_2$; Black; H. 7.5-8; G. 3.93; I.
Extremely hard.
- DIAMOND**, C; Colorless, yellow, red, blue, gray, black; Cl. tetrahedral; H. 10; G. 3.52; p. 281.

INDEX

Numbers printed in italics refer to Part I; those in black-faced type, to Part II; and those in roman type, to Part III.

A

- Abbreviations, 595, 617.
 Acanthite, **301**, 630.
 Achroite, **475**.
 Acicular habit, **366**.
 Acid salts, **227**.
 Acids, silicic, **233**.
 Aemite, **420**, 660.
 Actinolite, **433**, 677.
 Acute bisectrix, *173*.
 Adamantine luster, **379**.
 Adamantine spar, **343**.
 Adamite, **513**.
 Adelite, 653.
 Adularia, **408**.
 Ænigmatite, **435**, 659.
 Æschynite, 634, 668.
 Agate, **360**.
 Moss, **360**.
 Aggregate, **265**.
 Agricolite, 651.
 Aguilarite, 627.
 Aikinite, 628.
 Airy's spirals, *197*.
 Alabandite, **304**, 631, 666.
 Alabaster, **537**.
 Albite, **411**, 604, 614, 676.
 Alexandrite, **378**.
 Algodonite, 621.
 Alkalies, **222**, 562.
 Alkaline curths, 565.
 Alkaline reaction, 565.
 Allaetite, 652.
 Allanite, **468**, 596, 604, 633, 658.
 Allemontite, 620.
 Alloclasite, 622.
 Allophane, **502**, 678.
 Almandite, **444**, 659.
 Altaite, 625.
 Alternating axis, *15*.
 symmetry, *15*.
 Alum, **542**.
 Aluvian, 677.
 Aluminite, **233**, **337**, **542**, 677.
 Aluminium, Tests, 568.
 Alunite, **541**, 679.
 Alunogen, **542**, 600, 638.
 Alurgite, 672.
 Amalgam, 631.
 Amaranite, 636.
 Amazon stone, **411**.
 Amblygonite, **512**, 657.
 Amethyst, **350**.
 Ammonium, tests for, 565.
 Amorphous, *3*, **238**.
 Amphiboles, **431**, **432**, 604, 608, 615.
 Amplitude, *181*.
 Amygdaloidal, **271**.
 Amygdule, **271**.
 Analcite, **485**, 603, 610, 673.
 Analogous pole, **475**.
 Analyzer, *177*.
 Analysis, **227**.
 Anatase (octahedrite), **347**, **351**.
 Andalusite, **459**, 605, 616, 681.
 Andesine, **414**.
 Andorite, 623.
 Andradite, **444**, 659.
 Angle, between faces, *10*.
 between normals, *12*.
 between optic axes, *205*.
 constancy of, *10*.
 critical, *166*.
 of extinction, *185*.
 Anglesite, **532**, 602, 647.
 Anhydrite, **531**, 602, 662.
 Anisotropic, *163*.
 Ankerite, 657.
 Annabergite, **316**, **517**, **651**.
 Anomite, **493**.
 Anorthite, **413**, 604, 676.
 Anthophyllite, 677, 682.
 Antilogous pole, **475**.
 Antimonides, **294**.
 Antimony, **293**, 623.
 glance, **295**.
 oxides, **346**.
 tests, 584.
 Apatite, *95*, **508**, 603, 611, 655.
 Aphanthalite, 637.
 Apjohnite, 639.
 Aplome, **444**.
 Apophyllite, **480**, 603, 672.

Apparatus blowpipe, 546.
 Apparent angle, 206.
 Aquamarine, 437.
 Aragonite, 392, 602, 660.
 Ardenite, 665.
 Arfvedsonite, 435, 659.
 Argentite, 297, 596, 630.
 Argyrodite, 630.
 Arsenates, 236.
 Arsenic, 293, 620.
 tests, 585.
 Arsenical pyrite, 318.
 Arsenic oxides, 346.
 Arsenides, 232, 294.
 Arseniosiderite, 652.
 Arsenolite, 346, 640.
 Arsenopyrite, 318, 597, 622.
 Arzrunite, 642.
 Asbestos, 433, 500.
 Asbolite, 369.
 Astrophyllite, 659.
 Assay, 578.
 Asymmetric, 132.
 Atacamite, 334, 644.
 Atomic weights, 223.
 Augelite, 656.
 Augite, 123, 424, 676.
 Aurichalcite, 641.
 Autunite, 520, 655.
 Awaruite, 632.
 Axes, Crystallographic, 15.
 calculations, 83, 128.
 hexagonal, 85.
 monoclinic, 128.
 orthorhombic, 120.
 projection of, 35.
 Axial angles, 16.
 optic, 205.
 Axial planes, 16.
 Axial ratios, 24.
 Axinite, 469, 664.
 Axis, didigonal, 14.
 digonal, 14.
 dihexagonal, 14.
 ditetragonal, 14.
 hexagonal, 14.
 of alternating symmetry, 15.
 optic, 198.
 polar, 55.
 trigonal, 14.
 tetragonal, 14.
 twinning, 138.
 zonal, 22.
 Azurite, 399, 608, 641.

B

Babingtonite, 660.
 Baddeleyite, 682.
 Bakerite, 664.

Balance, Joly's, 261.
 Westphal, 264.
 Barite, 116, 528, 601, 662.
 Barium, tests, 565.
 Barkevikite, 435.
 Barrandite, 654.
 Barysilite, 648.
 Barytoalcite, 395, 660.
 Basal cleavage, 256.
 Basal pinacoid, 68.
 Basic salts, 226.
 Base, 68.
 Bastnäsité, 679.
 Baumhauerite, 622.
 Bauxite, 366, 602, 678.
 Baveno twins, 406.
 Bayldonite, 643.
 Bechilite, 664.
 Beegerite, 628.
 Belonesite, 670.
 Bementite, 666.
 Benitoite, 103, 505, 668.
 Beresonite, 647.
 Berthierite, 320, 625.
 Bertrandite, 680.
 Beryl, 89, 436, 605, 682.
 Beryllium, tests, 571.
 Beryllonite, 657.
 Berzelianite, 627.
 Berzeliite, 652.
 Beudantite, 646.
 Bevelment, 22.
 Beyrichite, 307, 630.
 Biaxial, 171.
 Biaxial interference, 200.
 Bieberite, 637.
 Bindheimite, 647.
 Binnite, 621.
 Biotite, 492, 601, 615, 660, 672.
 Birefringency, 168.
 sign of, 194.
 Bisectrices, 173.
 dispersion, 207.
 Bismite, 346.
 Bismuth, 293, 629.
 tests, 580.
 Bismuthinite, 296, 629.
 Bismutite, 650.
 Bismutosmaltite, 622.
 Bismutosphærite, 650.
 Bixbyite, 633.
 Black jack, 301.
 Black sands, 288.
 Blende, 301.
 Bloodite, 539, 637.
 Bloodstone, 360.
 Blue earth, 283, 444.
 Blue vitriol, 540.
 Bobierite, 657.
 Bog iron ore, 363.
 Boleite (percyllite), 644.

- Bone ash, 559.
 Bone phosphate, **509**.
 Bone turquoise, **517**.
 Boracite, **522**, 663.
 Borates, **236**, **507**.
 Borax, **522**, 600, 640.
 Borax bead, 553.
 Boriekite, 654.
 Bornite, **310**, 599, 629.
 Boron, tests, 591.
 Bort, **282**.
 Botryogen, 636.
 Botryoidal, **273**.
 Boulangerite, **321**, 624.
 Bournonite, **321**, 597, 623.
 Boussingaultite, 638.
 Brachy-axis, **113**.
 Brachydomes, **115**.
 Brachypinacoid, **116**.
 Brachyprism, **115**.
 Brackenbuskite, 649.
 Brandtite, 652.
 Braunnite, 632.
 Brazilian twins, **146**.
 Breithauptite, **309**, 625.
 Breunnerite, 657, 661.
 Brewsterite, **479**, 670, 673.
 Brittle, **258**.
 Brittle micas, **496**.
 Brochantite, **541**, 642.
 Bromine, tests, 588.
 Bromlite, **395**, 660.
 Bromyrite, **330**, 645.
 Brongniardite, 623.
 Bronzite, **421**.
 Brookite, **351**, 634, 668.
 Bruceite, **91**, **362**, 601, 663.
 Brushite, 656.
 Bunsenite, **340**.
 Bytownite, **414**.
- C
- Cabrerite, 651.
 Cacoenite, 655.
 Cadmium, tests, 581.
 Caesium, tests, 564.
 Calamine, **118**, **472**, 603, 650.
 Calaverite, 626.
 Calcioferrite, 654.
 Calciovolborthite, 645.
 Calcite, **91**, **380**, 602, 612, 660.
 twins, **145**, **146**, **382**.
 Calcium, tests, 566.
 Calculations of axes, **83**, **112**, **120**, **128**.
 formula, **231**.
 2 V, **205**.
 Caledonite, 642.
 Callaimite, 656.
 Calomel, 641.
 Cancrinite, **441**, 673.
 Canfieldite, 630.
 Cape ruby, **443**.
 Capillary, habit, **266**.
 Cappelenite, 665.
 Caracolite, 646.
 Carat, **282**.
 Carbon, tests, 590.
 Carbonado, **282**.
 Carbonates, **233**, **370**.
 Carbonates, basic, **227**.
 Carbuncle, **444**.
 Carlsbad twins, **148**, **405**.
 Carminite, 646.
 Carnallite, **335**, 639.
 Carnelian, **360**.
 Carnotite, **514**, 670.
 Carpholite, 666.
 Carposiderite, 637.
 Caryocerate, 665.
 Cassiterite, **347**, 596, 598, 631, 646.
 Castanite, 636.
 Catapleite, 673.
 Cat's-eye, **379**.
 Celestite, **530**, 662.
 Celsius, **414**.
 Cenosite, 673.
 Center of symmetry, **16**.
 Central, ditesseral, **47**,
 tesseral, **59**.
 Centrosymmetric, **130**.
 Cerargyrite, **330**, 601, 645.
 Cerite, 679.
 Cerium, tests, 572.
 Cerussite, **396**, 602, 647.
 Cervantite, **296**.
 Chabazite, **484**, 603, 672.
 Chalcanthite, **540**, 641.
 Chalcedony, **360**, 681.
 Chalcocite, **300**, 596, 629.
 Chalcomenite, 645.
 Chalcophanite, 632.
 Chalcophyllite, 643.
 Chalcopyrite, **310**, 599, 629.
 Chalcosiderite, 643.
 Chalcostibite, **320**, 623.
 Chalcotrichite, **339**.
 Chalk, **385**.
 Chalybite, **388**.
 Charcoal, 551.
 coats on, 552.
 Chemical formula, **231**.
 Chenevixite, 642.
 Chessylite, **399**.
 Chiasolite, **460**.
 Childrenite, 654.
 Chile saltpeter, **520**.
 Chiolite, 662.
 Chiviaticite, 628.
 Chloanthite, **315**, 622.
 Chlor-apatite, **509**.
 Chlorides, **327**.

- Chlorine, tests, 588.
 Chlorite, **497**, 601, 615.
 Chloropal, 659, 660.
 Chlorophane, **332**.
 Chondrodite, **471**, 679.
 Chromates, **236**.
 Chromic iron ore, **376**.
 Chromite, **233**, **337**, **376**, 596, 609, 634, 659.
 Chromium, tests, 568.
 Chrysoberyl, **377**, 681.
 Chrysocolla, **503**, 601, 644.
 Chrysolite, **446**, 680.
 Chrysoprase, **360**.
 Chrysotile, **500**.
 Churchite, 657.
 Cinnabar, **304**, 598, 629, 641.
 Cinnamon stone, **443**.
 Circular polarization, *196*.
 Cirrolite, 655.
 Citrine, **359**.
 Classes of crystals, *47*.
 Classification of minerals, **222**, **232**.
 Claudetite, **346**, 640.
 Clausthalite, 627.
 Clay, **502**.
 Cleavage, **256**.
 Cleveite, **525**.
 Cliftonite, **284**.
 Clinooxis, *120*.
 Clinoclone, **497**, 672, 678.
 Clinoclasite, 643.
 Clinodome, *123*.
 Clinographic projections, *33*.
 Clinohedrite, *127*, 650.
 Clinohumite, **471**, 679.
 Clinopinacoid, *123*.
 Clinzoisite, **465**, 674, 676.
 Clintonite, **496**, **497**, 678.
 Closed tube, 557.
 Clove oil, *215*.
 Cobalt bloom, **517**.
 Cobalt solution, 562.
 Cobalt, tests, 574.
 Cobaltite, **316**, 597, 621.
 Colemanite, **524**, 664.
 Collophanite, 655.
 Coloradoite, 626.
 Color, of beads, 594.
 of coats, 593.
 of flame, 552,
 of minerals, **273**.
 order of, *183*.
 Columbates, **236**.
 Columbite, **505**, 596, 634.
 Columbiun, tests, 570.
 Columnar habit, **265**.
 Combinations of forms, *22*, *53*.
 Common garnet, **442**.
 Common opal, **369**.
 Common salt, **327**.
 Compact structure, **268**.
 Compensation, *189*.
 Compensator, *189*.
 Composition, chemical, **231**.
 plane, *138*.
 Comptonite, **488**.
 Conchoidal fracture, **258**.
 Conichalcite, 643.
 Connellite, 642.
 Constancy of angles, *10*.
 Constitutional formula, **234**.
 Constitution, water of, **226**.
 Contact goniometer, *12*, *149*.
 Contunnite, 641.
 Convergent light, *191*.
 Cookeite, **496**, 671.
 Copiapite, 636.
 Copper, **288**, 598, 631.
 glance, **300**.
 pyrite, **310**.
 tests, 580.
 Copperas, **539**.
 Coprolites, **509**.
 Coquimbite, **540**, 636.
 Cordierite, **440**.
 Cornwallite, 643.
 Corundophilite, **498**.
 Corundum, *91*, **341**, 605, 611, 681.
 Corynite, 622.
 Cosalite, 628.
 Cotunnite, 647.
 Covellite, **306**, 629, 644.
 Crednerite, 631.
 Critical angle, *166*.
 Crocidolite, **435**, 659.
 Crocoite, **533**, 649.
 Cronstedtite, 658.
 Crookesite, 627.
 Crossed dispersion, *209*.
 Crossed nicols, *186*.
 Cryolite, **333**, 601, 662.
 Crystal, *6*.
 axes, *15*.
 aggregate, *135*.
 forms, *21*.
 measurement, *153*.
 structure, *4*.
 Crystalline, *3*, **238**.
 Crystalline elements, *24*.
 Crystallization, *6*, **245**.
 Crystals, *1*.
 optical properties, *160*.
 physical properties, **256**.
 Cubanite, 629.
 Cube, *51*.
 Cubic system, *47*.
 Cullinan diamond, **283**.
 Cumengite, 644.
 Cuprite, **337**, 598, 631, 644.
 Cuprobismutite, 628.
 Cupriodargyrite, 645.

Cuprotungstite, **544**, 645.
 Curvature of face, **268**.
 Curve of hardness, **259**.
 Cyanite, **461**, 604, 615, 681.
 Cyanochroite, 641.
 Cyanotrichite, 642.
 Cyclic twins, *142*.
 Cylindrite, 624.

D

Danalite, 649.
 Danburite, 664.
 Darapskite, 637.
 Datolite, **463**, 603, 664.
 Dawsonite, 661.
 Decrepitation, 552.
 Demantoid, **444**.
 Dendritic, **269**.
 Density, **260**.
 Derbylite, 634.
 Derivation of forms, *52*.
 Descloizite, **514**, 648.
 Description of minerals, **281-545**.
 Descriptive terms, **265**.
 Determination tables, 595.
 Deweylite, 671, 678.
 Diadochite, 654.
 Diallage, **424**.
 Diamond, **281**, 682.
 Diaphorite, 624.
 Diaspore, **365**, 680.
 Diatomaceous earth, **371**.
 Dichroism, *189*.
 Dichroite, **440**.
 Dichroscope, *190*.
 Dickinsonite, 653.
 Didigonal axis, *14*.
 equatorial, *113*.
 polar, *117*.
 Dietrichite, 636.
 Dietzeite, 663.
 Digonal axis, *14*.
 equatorial, *121*.
 holoaxial, *118*.
 polar, *124*.
 Dihexagonal alternating, *89*.
 axis, *14*.
 equatorial, *85*.
 hemipyramid, *92*.
 polar, *92*.
 pyramid, *86*.
 prism, *87*.
 Dihydrate, 644.
 Dimetasilicic acid, **234**.
 Dimorphism, **220**.
 Diopside, **423**, 677.
 Dioptase, *99*, **452**, 644.
 Diorthosilicate, **233**.
 Dioxides, **347**.

Diploid, *59*.
 Directional properties, **3**.
 Disluite, 650.
 Dispersion, of light, *166*.
 of optic axes, *206*.
 of the bisectrix, *207*.
 crossed, *208*.
 horizontal, *208*.
 inclined, *208*.
 Disthene, **462**.
 Distortion, **28**.
 Ditesseral central, *47*.
 polar, *54*.
 Ditetragonal alternating, *69*.
 axes, *14*.
 equatorial, *65*.
 hemipyramid, *72*.
 polar, *71*.
 prism, *67*.
 pyramid, *66*.
 Ditrifonal axis, *14*.
 equatorial, *101*.
 hemipyramid, *103*.
 polar, *103*.
 prism, *102*.
 pyramid, *101*.
 Dodecahedron, pentagonal, *60*.
 rhombic, *52*.
 Dog-tooth spar, **381**.
 Dolerophane, 642.
 Dolomite, *99*, **387**, 602, 660.
 Dome, *113*, *115*.
 Domeykite, 621.
 Double refraction, *168*.
 Drawing of crystals, *31*.
 Drusy, **268**.
 Ductility, **258**.
 Dufrenite, **510**, **515**, 654.
 Dufrenoyite, 622.
 Dull luster, **279**.
 Dumortierite, 681.
 Durangite, 653.
 Dyscrasite, 625.
 Dysluite, **377**.

E

Ecdemite, 646.
 Eclogite, **445**.
 Edingtonite, 479, 671.
 Effloresce, **225**.
 Eglestonite, 641.
 Eisenrosen, **344**.
 Elacolite, **440**.
 Elastic, **257**.
 Electron, **291**, 631.
 Elements, **220**, **232**, **281**.
 table of, **223**.
 Ellipsoid, *184*.

- Ellipsoid, Fletcher, 185.
 of revolution, 184.
 Embolite, 330, 645.
 Emerald, 436.
 Emery, 343.
 Emplectite, 320, 628.
 Enantiomorphous, 27.
 Enargite, 326.
 Endlicheite, 511.
 Enstatite, 421, 604, 613, 677, 681.
 Epiboulangerite, 624.
 Epididymite, 674, 676.
 Epidote, 464, 466, 605, 616, 674, 676.
 Epigenite, 621.
 Epistilbite, 479, 671.
 Epsomite, 119, 538, 600, 638.
 Equatorial, 126.
 didigonal, 113.
 digonal, 121.
 dihexagonal, 85.
 ditetragonal, 65.
 ditrigonal, 101.
 hexagonal, 93.
 tetragonal, 72.
 trigonal, 105.
 Erbium, tests, 572.
 Erinite, 643.
 Erythrite, 517, 651.
 Etch figures, 62, 78.
 Ettringite, 662.
 Eucairite, 627.
 Euchroite, 643.
 Euclase, 680.
 Eucryptite, 441.
 Eudialyte, 665.
 Eudidymite, 674, 676.
 Eulytite, 651.
 Eutectics, 241.
 Euxenite, 668.
 Evansite, 518, 656.
 Excelsior, diamond, 283.
 Expansion, 3.
 Extinction, 186.
 angles, 185, 198.
 inclined, 198.
 parallel, 187.
 straight, 187.
 Extraordinary ray, 169.
- F
- Faces, similar, 11.
 vicinal, 267.
 Fairfieldite, 655.
 False topaz, 359.
 Famatinite, 623.
 Faujasite, 673.
 Fayalite, 450, 658.
 Feldsite, 408.
 Feldspar group, 403, 404.
 lime, 413.
 Feldspar soda, 411.
 potash, 403.
 Feldspars, monoclinic, 403.
 triclinic, 411.
 Feldspathoids, 439.
 Felsöbanyite, 677.
 Ferberite, 542.
 Fergusonite, 506, 634, 669.
 Ferronatrite, 635.
 Ferrites, 233, 337.
 Fibroferrite, 636.
 Fibrolite, 461.
 Fibrous, 266.
 Fillowite, 653.
 First median line, 173.
 First order colors, 184.
 Fischerite, 656.
 Flame, 548.
 Flame coloration, 553.
 Fletcher ellipsoid, 185.
 Flinkite, 652.
 Flint, 361.
 Florencite, 656.
 Flos ferri, 393.
 Fluellite, 679.
 Fluocerite, 678.
 Fluor-apatite, 509.
 Fluorescence, 280.
 Fluorine, tests, 589.
 Fluorite, 331, 603, 609, 662.
 Fluorspar, 331, 609, 662.
 Foliated, 269.
 Fontainebleau, 380.
 Footeite, 644.
 Forbesite, 651.
 Forms, 21.
 derivation, 25.
 enantiomorphic, 27.
 fundamental, 23.
 gyroidal, 26.
 hemihedral, 25.
 holohedral, 24.
 holosymmetric, 23.
 polar, 55.
 tetartohedral, 27.
 Formula, empirical, 227.
 general, 231.
 molecular, 2.
 structural, 227.
 Forsterite, 450, 680.
 Fowlerite, 430.
 Fracture, 256, 258.
 Franckeite, 624.
 Franklinite, 375, 596, 633.
 Freezing point, 1.
 Freibergite, 325.
 Freieslebenite, 624.
 Friable, 258.
 Friedelite, 666.
 Fuchsite, 490.
 Fusibility, 555.

G

Gadolinite, 681.
 Gageite, 340.
 Gahnite, 377, 650.
 Galena, 298, 627.
 Galenite, 298, 597, 627.
 Galenobismuthite, 320, 628.
 Gallium, tests, 577.
 Ganomalite, 618.
 Ganophyllite, 666.
 Garnet, 442, 605, 610.
 — composition, 231.
 — group, 442.
 — precious, 443.
 Garnierite, 500, 608.
 Gaylussite, 401, 661.
 Gearksutite, 663.
 Gehlenite, 681.
 Gelatinization, 591.
 Geniculate twins, 141.
 Genthite, 500, 669.
 Georonite, 624.
 Geodes, 270.
 Gerhardtite, 645.
 Germanium, tests, 586.
 Gersdorffite, 316, 597, 622.
 Geyselite, 370.
 Ghost, 276.
 Gibbsite, 365, 656, 678.
 Gismondite, 479, 671.
 Glass, 610.
 Glassware, 556.
 Glassy, 279.
 Glauberite, 528, 662.
 Glaucocroite, 665.
 Glaucodote, 319, 621.
 Glaucophane, 676.
 Gmelinite, 479, 671.
 Goethite, 658.
 Gold, 291, 582, 631.
 Goldschmidtite, 626.
 Goniometer, 11.
 — contact, 12, 149.
 — reflecting, 12, 150.
 — signal, 152.
 — two-circle, 150.
 — use of, 149.
 Goslarite, 539, 639.
 Gossan, 253.
 Göthite, 363, 633.
 Goyazite, 656.
 Granular structure, 268.
 Graphite, 284, 596, 597, 609, 634.
 Gravity, specific, 260.
 Greasy luster, 279.
 Greenockite, 93, 306, 651.
 Grossularite, 443, 676.
 Ground water, 251.
 Grünlingite, 626.
 Guanajuatite, 627.

Guarinite, 667.
 Guitermanite, 622.
 Gunnite, 526.
 Gypsum, 536, 601, 613, 662.
 Gyrolite, 671.

H

Habit, 29.
 Hackly fracture, 258.
 Haidingerite, 653.
 Halite, 79, 327, 600, 639.
 Hydroids, 233, 327.
 Halotrichite, 636.
 Hamlinite, 655.
 Hancockite, 648.
 Hanksite, 89, 535, 637.
 Hardness, 258, 259.
 Hardystonite, 649.
 Hambergite, 664.
 Harmotome, 482, 670, 672.
 Hatchettolite, 668.
 Hauebecornite, 625.
 Hauerite, 631.
 Hausmannite, 632.
 Häuyn, 438, 674.
 Häuynite, 438, 674.
 Heat conductivity, 3.
 — of fusion, 239.
 Heating, in closed tube, 557.
 — in open tube, 558.
 — on charcoal, 551.
 Heavy liquids, 263, 264.
 Heavy spar, 528.
 Hedenbergite, 424.
 Heintzite, 664.
 Helvite, 666.
 Hemafibrite, 652.
 Hematite, 91, 343, 596, 598, 607, 609, 634, 657.
 Hematolite, 652.
 Hemidomes, 117.
 Hemihedrism, diagonal-faced, 26.
 — gyroidal, 26.
 — parallel-faced, 26.
 Hemimorphism, 25.
 Hemimorphite, 118, 472.
 Hemiorthodome, 127.
 — pyramid, 117.
 — prism, 126.
 Hercynite, 371, 682.
 Herderite, 655.
 Herregrundite, 642.
 Hessite, 626.
 Hessonite, 443.
 Heulandite, 481, 603, 670.
 Hexagonal alternatiag, 97.
 — axes, 85.
 — axial ratio, 112.
 — axis, 14.
 — equatorial, 93.
 — hemipyramid, 1st order, 92.

- Hexagonal hemipyramid, 2d order, *92*.
 hemipyramid, 3d order, *100*.
 holoaxial, *95*.
 holosymmetric, *85*.
 polar, *90*.
 prism, 1st order, *88*.
 2d order, *88*.
 3d order, *94*.
 pyramid 1st order, *86*.
 2d order, *87*.
 3d order, *94*.
 system, *17, 84*.
 trapezohedron, *96*
- Hexahedron, *51*.
 Hexagonite, *433*.
 Hexoctahedron, *48*.
 Hextetrahedron, *55*.
 Hiddenite, *427*.
 Hielmite, *635*.
 Hiortdahlite, *675*.
 Hisingerite, *659*.
 Hoernesite, *653*.
 Holoaxial, *61*.
 digonal, *118*.
 hexagonal, *95*.
 tesseral, *61*.
 tetragonal, *75*.
 trigonal, *108*.
 Holohedral, *24*.
 Holosymmetric, *24*.
 cubic, *47*.
 hexagonal, *85*.
 monoclinic, *121*.
 orthorhombic, *113*.
 tetragonal, *65*.
 triclinic, *130*.
- Homilite, *664*.
 Hope diamond, *282*.
 Hopeite, *650*.
 Horizontal dispersion, *208*.
 Hornblende, *433, 676*.
 Horn silver, *330*.
 Horseflesh ore, *310*.
 Hortonolite, *658*.
 Howlite, *664*.
 Hübnerite, *542, 665*.
 Humite, *471, 679*.
 Hyacinth, *458*.
 Hyalite, *370*.
 Hyalotekite, *648*.
 Hydrargillite, *365*.
 Hydroboracite, *664*.
 Hydrocerussite, *647*.
 Hydrochloric acid, *560*.
 Hydrocyanite, *641*.
 Hydrofluoric acid, *233*.
 Hydrogen sulphide, *232*.
 Hydrogiobertite, *661*.
 Hydroherderite, *655*.
 Hydromagnesite, *362, 661*.
 Hydronephelite, *479, 673*.
 Hydrophilite, *639*.
 Hydrotalcite, *663*.
 Hydroxides, *362*.
 Hydrozincite, *649*.
 Hypersthene, *421, 604, 616, 682*.
- I
- Ice, *337*.
 Iceland spar, *384*.
 Icositetrahedron, *61*.
 Idocrase, *456*.
 Ilhite, *636*.
 Ilesite, *636*.
 Ilmenite, *346, 609, 633*.
 Ilvaite, *472, 633, 658*.
 Inclined dispersion, *208*.
 Inclusions, *9*.
 Index of refraction, *165, 217*.
 determination of, *209*.
 Indicatrix, *185, 197*.
 Indices, *18*.
 determination of, *156*.
 law of rational, *20*.
 of refraction, *165, 209*.
- Indicolite, *475*.
 Indium, tests, *577*.
 Inesite, *666*.
 Interecepts, *18*.
 Interference, *181*.
 colors, *183*.
 Interference figure, biaxial, *200*.
 uniaxial, *191*.
 Intergrowths of minerals, *243*.
 Interpenetration twins, *141*.
 Intumescence, *555*.
 Iodine, *589*.
 Iodobromite, *645*.
 Iodyrite, *330, 646*.
 Iolite, *440, 613, 680*.
 Iridescence, *183, 274*.
 Iridium, *632*.
 Iridium, tests, *582*.
 Iridosmine, *632*.
 Iron, *631*.
 Iron cap, *253*.
 Iron, tests for, *575*.
 native, *293*.
 specular, *344*.
 titaniferous, *346*.
- Irregularity of crystals, *29*.
 Isoclasite, *656*.
 Isometric system, *16, 47*.
 Isomorphism, *228*.
 Isomorphous groups, *229*.
 Isomorphous mixture, *229*.
 Isotropic crystals, *163*.
 Itacolomite, *282*.
- J
- Jacobsite, *371, 633*.
 Jacynth, *458*.

Jade, **426**.
 Jadeite, **420, 426, 676**.
 Jamesonite, **320, 624**.
 Jargon, **458**.
 Jarosite, **635**.
 Jasper, **361**.
 Jeffersonite, **424, 650**.
 Jeremejevite, **665**.
 Jordanite, **622**.
 Josephinite, **632**.
 Joly's balance, **261**.

K

Kainite, **534, 638**.
 Kalgoorlite, **626**.
 Kalinite, **542, 600, 638**.
 Kaliophilite, **441**.
 Kallilite, **625**.
 Kämmererite, **669**.
 Kaolin, **501**.
 Kaoliinite, **501, 601, 613, 678**.
 Keilhauite, **668**.
 Kentrolite, **627, 648**.
 Kermesite, **640**.
 Kieserite, **335, 539, 638**.
 Kilbrickenite, **624**.
 Klaprotholite, **628**.
 Knebelite, **451, 658**.
 Knoxvillite, **636**.
 Kobellite, **625**.
 Koh-i-noor diamond, **282**.
 Koninckite, **655**.
 Kornerupine, **681**.
 Krennerite, **626**.
 Kröhnkite, **641**.
 Kunzite, **427**.

L

Labradorite, **416, 604, 674**.
 Lamellar, **269**.
 Lampadite, **369**.
 Längbeinite, **638**.
 Langite, **642**.
 Lanthanum, tests, **572**.
 Lapis-lazuli, **439, 608**.
 Larkinite, **652**.
 Laumontite, **479, 671**.
 Laurionite, **647**.
 Laurite, **287**.
 Lautarite, **663**.
 Lautite, **621**.
 Law, of rational indices, **19**.
 Lawsonite, **674**.
 Lazulite, **515, 654, 656**.
 Lazurite, **438, 674**.
 Lead, **293, 628**.
 coat, **580**.
 oxide, **341**.
 tests for, **579**.
 use of test, **559**.
 Leadhillite, **646**.

Lecontite, **637**.
 Left-handed crystal, **27**.
 Lenarkite, **647**.
 Lengbachite, **621**.
 Lepidolite, **495, 601, 671**.
 Lepidomelane, **659**.
 Lettering, **33**.
 Leucite, **416, 604, 613, 680**.
 Leucochalcite, **643**.
 Leucophanite, **672**.
 Leucophoenicite, **650**.
 Leucopyrite, **622**.
 Leucocene, **347**.
 Levynite, **671**.
 Libethenite, **513, 644**.
 Light, **160**.
 interference, **181**.
 convergent, **192**.
 polarized, **175**.
 Light waves, **161**.
 refraction of, **164**.
 Lillianite, **628**.
 Limestone, **385**.
 Limonite, **363, 596, 606, 607, 633, 658**.
 Linarite, **642**.
 Lindackerite, **642**.
 Linneite, **631**.
 Lintonite, **488**.
 Liroconite, **643**.
 Lithia mica, **495**.
 Lithium, tests, **564**.
 flux, **559**.
 Livingstonite, **623**.
 Lodestone, **374**.
 Löllingite, **622**.
 Lorandite, **640**.
 Lossenite, **646**.
 Löweite, **539, 637**.
 Löwigite, **677**.
 Ludlamite, **654**.
 Lüneburgite, **657**.
 Luster, **273, 278**.
 Lydia stone, **361**.

M

Macro-axis, **113**.
 Macrodome, **115**.
 Macropinacoid, **116**.
 Macroprism, **115**.
 Macropyramid, **114**.
 Magma, **243**.
 Magnesia micas, **497**.
 Magnesium, tests, **567**.
 Magnesite, **386, 602, 661**.
 Magnesoferrite, **634**.
 Magnetism, **552**.
 Magnetite, **373, 596, 609**.
 Malachite, **398, 608, 641**.
 Malacon, **458**.
 Mallardite, **639**.
 Malleability, **258**.

- Mamillary, **273**.
 Manebach twins, **406**.
 Manganese, tests, **574**.
 Manganite, **367**, **596**, **632**.
 Mangano-columbite, **665**.
 Manganoferrite, **371**.
 Manganosite, **340**, **667**.
 Manganostibnite, **651**.
 Marble, **385**.
 Marcasite, **317**, **599**, **630**.
 Margarite, **496**, **672**.
 Marialite, **453**, **676**.
 Marshite, **645**.
 Martinite, **656**.
 Martite, **345**.
 Mascagnite, **638**.
 Massicot, **341**, **649**.
 Massive, **268**.
 Matildite, **629**.
 Matrass, **557**.
 Mauzeilite, **646**.
 Mazapilite, **652**.
 Mean refractive index, **171**.
 Measurement of crystals, **149**.
 Meerschau, **501**.
 Meionite, **453**.
 Melaconite, **340**, **596**, **631**.
 Melanite, **444**.
 Melanocerite, **665**.
 Melanophlogite, **680**.
 Melanostibian, **633**.
 Melanotekite, **628**, **648**.
 Melanterite, **539**, **600**, **636**.
 Melilite, **675**.
 Melonite, **626**.
 Melting point, **238**.
 Menaccanite, **346**, **596**.
 Mendeleef's table, **223**.
 Mendozite, **637**.
 Meneghinite, **624**.
 Mercury, **293**, **631**.
 Mercury, tests, **579**.
 Mesitite, **229**, **388**.
 Mesolite, **673**.
 Metacinnabar, **305**.
 Metallic luster, **274**.
 Metallic mirror, **557**.
 Metamorphism, **248**.
 Metasilicates, **233**.
 Metasilicic acid, **233**.
 Metastable, **243**.
 Metavoltaite, **635**.
 Methylene iodide, **211**, **263**.
 Miargyrite, **625**.
 Mica, **488**.
 brittle, **496**.
 group, **488**.
 percussion figure, **489**.
 plate, **194**.
 1st class, **493**.
 2d class, **493**.
 Micaceous, **257**.
 cleavage, **489**.
 hematite, **343**.
 Microcline, **409**, **604**, **613**, **675**.
 Microlite, **669**.
 Micropertthite, **408**.
 Microsommite, **674**.
 Miersite, **646**.
 Milarite, **675**.
 Millerian indices, **18**.
 Millerite, **307**, **599**, **630**.
 Mimetite, **95**, **512**, **646**.
 Mineral; **219**.
 groups, **232**.
 Mineralizers, **246**.
 Minerals, color of, **273**.
 index of refraction, **165**.
 luster of, **274**, **278**.
 rock-forming, **609**.
 specific gravity, **260**.
 table of, **617**.
 Minervite, **656**.
 Minium, **649**.
 Mirabilite, **535**, **600**, **637**.
 Mispickel, **318**.
 Mixite, **642**.
 Mizzonite, **453**.
 Models, **28**.
 Moh's scale of hardness, **259**.
 Molecular, volume, **228**.
 Molybdates, **236**.
 Molybdenite, **296**, **596**, **597**, **630**.
 Molybdenum, tests, **586**.
 Monazite, **507**, **603**, **657**.
 Monetite, **655**.
 Monobromonaphthalene, **215**.
 Monochromatic light, **183**.
 Monoclinic crystals, **120**.
 axial ratio, **128**.
 dispersion, **207**.
 extinction, **198**.
 pyroxenes, **423**.
 system, **17**, **120**.
 twins, **148**.
 Monoxides, **337**.
 Montanite, **651**.
 Montebasite, **657**.
 Monticellite, **449**.
 Montroydite, **641**.
 Mordenite, **479**, **672**.
 Morenosite, **539**, **637**, **669**.
 Morganite, **437**.
 Mosandrite, **668**.
 Moss agate, **361**.
 Mossite, **634**.
 Muscovite, **488**, **489**, **601**, **614**, **672**.

N

- Nadorite, **647**.
 Nagyagite, **625**.

- Nailhead spar, **379**.
 Nantokite, 614.
 Nasonite, 648.
 Native elements, **281**.
 Natrolite, **486**, 603, 673.
 Natron, **400**, 639.
 Natrophilite, 653.
 Naumannite, 627.
 Negative birefringence, *169*.
 crystals, *169*, *170*.
 forms, *27*, *79*.
 Nematite, **362**.
 Neodymium, 572.
 Nepheline, **440**, 604, 675.
 Nephelite, *100*, **440**, 604, 611, 675.
 Neptunite, **505**, 633, 666, 668.
 Nesquehonite, 661.
 Niccolite, **309**, 599, 622.
 Nickel, tests, 574.
 Nicols prism, *179*.
 Niobium (columbium), 570.
 Niter, **521**, 600, 639.
 Nitrates, **507**.
 tests, 590.
 Nitric acid, 560.
 Nitrobarite, 610.
 Nitrocalcite, **521**.
 Nodular, **269**.
 Non-metallic luster, **274**.
 Nordenskiöldine, 646.
 Normal, *43*.
 salt, **227**.
 Northupite, 661.
 Noscan, **438**.
 Noselite, **438**, 674.
 Nugget, **269**.
- O
- Obtuse bisectrix, *173*.
 Ocher, **365**.
 Ochrolite, 647.
 Octahedrite, **351**, 668.
 Octahedron, *52*.
 hex-, *49*.
 tetragonal tris-, *50*.
 trigonal tris-, *50*.
 Oldhamite, 662.
 Oligoclase, **415**.
 Olivenite, **513**, 643.
 Olivine, **446**, 605, 614, 680.
 Odors, 552, 557.
 Okenite, 671, 673.
 Onyx, **360**.
 Öölitic, **271**.
 Opal, **369**, 604, 609, 680.
 Opaque, **275**.
 Open tubes, 558.
 Optic axes, *172*, *198*.
 axial angle, *173*.
 measurement of, *205*.
 Optical characters, *174*.
 orientation, *174*, *175*.
 properties, *160*, *174*, *175*.
 sign, *169*, *194*, *204*.
 Ordinary ray, *169*.
 Organic compounds, 591.
 Oriental amethyst, **342**.
 emerald, **342**.
 topaz, **342**.
 Origin of minerals, **237**.
 Orloff diamond, **282**.
 Orochlorite, **497**.
 Orofrite, 627.
 Orpiment, **295**, 606, 640.
 Orthoaxis, *120*.
 Orthoclase, *128*, **404**, 604, 613, 675.
 Orthodome, *123*.
 Orthopinacoid, *123*.
 Orthoprism, *123*.
 Orthopyramids, *122*.
 Orthorhombic system, *17*, *113*.
 Orthosalts, **233**.
 Orthosilicates, **233**, **438**.
 Orthosilicic acid, **233**.
 Orthorhombic amphiboles, **431**.
 axial ratio, *120*.
 crystals, *113*.
 dispersion, *207*.
 hemihedral, *118*.
 hemipyramids, *117*.
 holoaxial, *118*.
 holohedral, *113*.
 holosymmetric, *113*.
 prisms, *115*.
 pyroxene, **419**.
 Oscillatory combinations, *137*.
 Osmium, tests, 582.
 Ottrelite, **497**.
 Oxidation, **251**.
 Oxides, **233**, **337**.
 Oxidizing flame, 549.
- P
- Paecholite, **334**, 663.
 Palladium, 632.
 tests, 582.
 Panderinite, **525**.
 Paragonite, 672.
 Parallel-faced hemihedrons, *26*.
 Parallel growths, *134*.
 Paramelaconite, 631.
 Parameters, *17*, *156*.
 topic, **228**.
 Parametral face, *23*.
 Parasite, 661.
 Parting, **257**.
 Partschinite, 666.
 Pearceite, 620.
 Pearly luster, **279**.

- Pectolite, **427**, 603, 673.
 Peganite, **518**, 656.
 Penfieldite, 647.
 Pentagonal dodecahedron, **60**.
 didodecahedron, **61**.
 Pentlandite, **308**, 630.
 Percussion figure, **489**.
 Percylite, 644.
 Pericase, **340**, 663.
 Pericline, twins, **410**.
 Peridot, **446**.
 Periodic table, **223**.
 Perovskite, **505**, 634, 668.
 Perpurite, 654.
 Perthite, **408**.
 Petalite, 675.
 Petzite, 626.
 Phantoms, **276**.
 Pharmacosiderite, 652.
 Phase, **238**.
 Phenacite, *99*, **452**, 682.
 Phenocrysts, *216*.
 Phillipsite, **479**, 673.
 Phlogopite, **494**, 601, 672.
 Phoenicochroite, 649.
 Phosgenite, 647.
 Phosphates, **236**, **507**.
 Phosphorescence, **279**.
 Phosphorus, tests, 590.
 Phosphosiderite, **510**, 654.
 Phosphuranylite, 655.
 Physical properties, **256**.
 Picotite, **372**.
 Pieromerite, **539**, 638.
 Piedmontite, **467**, 666.
 Pinacoid, *68*.
 basal, *116*, *123*.
 brachy-, *116*.
 cleavage, **256**.
 clino-, *123*.
 macro-, *116*.
 ortho-, *123*.
 Pinakiolite, 664.
 Pinnoite, 664.
 Pirssonite, 661.
 Pisanite, **540**, 641.
 Pisolitic, **271**.
 Pitchblende, **525**.
 Pitt diamond, **282**.
 Pitticite, 652.
 Placer mining, **291**.
 Plagioclase, **411**, 614.
 Plagiohedral, *26*.
 Plagionite, 624.
 Plane, axial, *173*.
 basal, *68*.
 composition, *138*.
 diametral, *16*.
 of polarization, *176*.
 Plane of symmetry, *13*.
 of vibration, *176*.
 Plane, parametral, *23*.
 twinning, *138*.
 Planoferrite, 658.
 Plaster of Paris, **537**.
 Platinum, **287**, 631.
 forceps, 554.
 tests, 582.
 wire, 553.
 Plattnerite, 628, 649.
 Pleochroism, *189*.
 Plumbago, **284**.
 Plumbojarosite, 647.
 Pneumatolysis, **248**.
 Point-system, *5*.
 Polar, *55*.
 axis, *55*.
 digonal, *124*.
 didigonal, *117*.
 dihexagonal, *92*.
 ditesseral, *54*.
 ditetragonal, *71*.
 ditrigonal, *103*.
 hexagonal, *99*.
 tesseral, *62*.
 tetragonal, *78*.
 trigonal, *110*.
 Polarization, of light, *175*.
 circular, *176*, *196*.
 Polarizer, *177*.
 Pole of face, *43*.
 Polianite, 632.
 Pollucite, 679.
 Polyadelphite, **444**.
 Polyargyrite, **326**, 625.
 Polybasite, **326**, 624.
 Polycrase, 635, 668.
 Polydymite, **307**, 630.
 Polyhalite, 662.
 Polythionite, **496**.
 Polymignite, 635.
 Polymorphism, **219**.
 Polysynthetic twins, *142*.
 Positive birefringence, *169*, *170*.
 Positive forms, *27*.
 Potash alum, **542**.
 Potash feldspar, **403**.
 Potash mica, **489**.
 Potassium mercuric iodide, **263**.
 Potassium, tests, 563.
 Powdery, **269**.
 Powellite, **544**, 670.
 Praseodymium, tests, 572.
 Precious garnet, **443**.
 opal, **369**.
 Prehnite, **470**, 604, 676.
 Pressure figure, **490**.
 Priceite, **525**.
 Primary optic axes, *172*.
 Primary minerals, **244**.
 Primitive circle, *43*.
 Prism, *113*.

- Prism, brachy, *115*.
 dihexagonal, *87*.
 ditetragonal, *67*.
 ditrigonal, *102*.
 macro, *115*.
 nicol, *179*.
 ortho, *123*.
 tetragonal, *67*.
 trigonal, *103*.
 1st order tetragonal, *67*.
 2d order hexagonal, *88*.
 3d order, hexagonal, *94*.
 2d order tetragonal, *68*.
- Prismatic cleavage, *256*.
 Prismatic habit, *265*.
 Prochlorite, *678*.
 Projection, *31*.
 axes, *35*.
 clinographic, *31, 33*.
 orthographic, *31*.
 stereographic, *42*.
- Prolectite, *679*.
 Prosopite, *663, 679*.
 Proustite, *323, 598, 607, 645*.
 Pseudobrookite, *634*.
 Pseudomalachite, *644*.
 Pseudomorph, *361, 363*.
 Pseudosymmetry, *141*.
 Psilomelane, *368, 596, 632*.
 Ptiolite, *479*.
 Pucherite, *651*.
 Pycnometer, *263*.
 Pyramid, *113*.
 dihexagonal, *86*.
 ditrigonal, *101*.
 hemi-, *71*.
 hexagonal, *86*.
 monoclinic, *122*.
 tetragonal, *66*.
 trigonal, *102*.
- Pyrargyrite, *322, 596, 607, 624, 645*.
 Pyrite, *313, 599, 609, 630*.
 arsenical, *318*.
 class, *313*.
 copper, *310*.
 group, *313*.
 magnetic, *308*.
 twins, *141*.
- Pyritohedron, *60*.
 Pyroaurite, *658*.
 Pyrochlore, *668*.
 Pyrochroite, *362, 632, 667*.
 Pyroelectric, *475*.
 Pyrolusite, *352, 596, 597, 632*.
 Pyromorphite, *95, 511, 602, 606, 648*.
 Pyrope, *443, 677*.
 Pyrophanane, *347*.
 Pyrophanite, *632*.
 Pyrophanite, *502, 678*.
 Pyrosphalite, *659*.
 Pyrostilpnite, *645*.
- Pyroxene, *604, 608, 615, 677*.
 group, *419, 420*.
 monoclinic, *423*.
 orthorhombic, *419*.
- Pyrrhotite, *308, 599, 609, 630*.
- Q
- Quartz, *110, 352, 605, 611, 681*.
 interference figure, *196*.
 rotary polarization, *197*.
 sinoky, *359*.
 wedge, *182, 184, 187, 196*.
- Quartzite, *356*.
 Quenstedtite, *636*.
 Quicksilver, *293*.
- R
- Radiated, *269*.
 Radicles, *224*.
 Radium, *514, 567*.
 Raimondite, *637*.
 Ralstonite, *679*.
 Rammelsbergite, *316, 622*.
 Ranite, *479*.
 Raspite, *649*.
 Rational indices, *19*.
 Ray, extraordinary, *169*.
 ordinary, *169*.
 Realgar, *294, 606, 640*.
 Reagents, *559, 560*.
 Reddingite, *655*.
 Reducing flame, *550*.
 Reduction with soda, *579*.
 Reentrant angle, *134*.
 Reflected light, *163*.
 Reflection goniometer, *12, 150*.
 Reflection twins, *140*.
 Refraction, *164*.
 double, *168*.
 indices of, *165*.
 mean index of, *171*.
 Refractometer, *212, 213*.
 Regent diamond, *282*.
 Reinite, *633*.
 Reningtonite, *669*.
 Rensslerite, *500*.
 Repeated twinning, *142*.
 Replacement, *22*.
 Resinous luster, *279*.
 Reticulated, *269*.
 Rhabdophanite, *657*.
 Rhagite, *650*.
 Rhodium, *582*.
 Rhodizite, *663*.
 Rhodochrosite, *391, 602, 667*.
 Rhodonite, *132, 430, 604*.
 Rhombic dodecahedron, *52*.
 Rhombohedral carbonates, *379*.

Rhombohedral, 90.
 Richardite, 626.
 Richterite, 667.
 Riebeckite, 435, 659.
 Right-handed crystals, 27, 197.
 Rinkite, 667.
 Ripidolite, 497.
 Roasting, 552.
 Rock crystal, 358.
 Rock salt, 327.
 Rock sections, 216.
 Roeblingite, 647.
 Romerite, 540, 636.
 Roepferite, 451.
 Röntgen ray, 280.
 Roscelite, 490, 670.
 Rotation twins, 137.
 Rotatory polarization, 196.
 Rubellite, 475.
 Rubidium, tests, 564.
 Ruby, 342.
 silver, 322, 323.
 spinel, 371.
 Ruthenium, 582.
 Rutile, 349, 597, 598, 605, 612, 634, 668.

S

Safflorite, 315, 621.
 Sagenite, 350.
 Salt, 240.
 Saltpeter, 521.
 Salts, 224.
 acid, 226.
 basic, 226.
 hydrated, 227.
 normal, 226.
 Samarium, 572.
 Sand, black, 288.
 green,
 Sandstone, 356.
 Sanidine, 408.
 Sapphire, 342.
 Sarcosite, 675.
 Sartorite, 320, 622.
 Sassolite, 523, 640.
 Satin spar, 537.
 Scale of colors, 184.
 of fusibility, 555.
 of hardness, 260.
 Scalenohedron, 90.
 tetragonal, 60, 70.
 Scandium, 572.
 Scapolite, 453, 612.
 Schapbachite, 628.
 Scheelite, 543, 603, 668.
 Schefferite, 424, 666.
 Schiller, 422.
 Schirmerite, 628.
 Schorl, 474.
 Schorlomite, 444, 667.
 Schwartzbergite, 648.
 Schwartzite, 325.
 Seleromater, 259.
 Seolecite, 479, 673.
 Scorodite, 652.
 Second order of colors, 184.
 Secondary enrichment, 253.
 Secondary minerals, 244.
 Secondary optic axes, 172.
 Seetility, 258.
 Selenite, 537.
 Selenium, 582, 587.
 Sellaite, 677.
 Senaite, 627.
 Senarmontite, 346, 640.
 Sensitive plate, 199.
 Sepiolite, 501, 601, 678.
 Sericite, 491.
 Serpentine, 498, 601, 614, 678.
 Sesquioxides, 341.
 Siderite, 91, 388, 602, 606, 657.
 Sideronatriite, 635.
 Sign of birefringence, 169, 173.
 Silicates, 233, 403.
 classification of, 233.
 silicic acids, 233.
 salts of, 233.
 Silicon, tests, 591.
 Silicified wood, 361.
 Silky luster, 279.
 Sillimanite, 461, 614, 681.
 Silver, 290, 578, 597, 631.
 glance, 297.
 Similar faces, 11.
 Sipyllite, 669.
 Skutterudite, 315, 621.
 Smaltite, 315, 598, 621.
 Smarskite, 634.
 Smithsonite, 392, 603, 649.
 Smoky quartz, 359.
 Snow, 337.
 Soapstone, 500.
 Soda, 558.
 Sodalite, 438, 604, 610, 675.
 Sodalite group, 438.
 Soda niter, 520, 600, 639.
 Sodium, tests for, 564.
 Solutions, 248.
 Space-lattice, 4.
 Spadaite, 671.
 Spangolite, 642.
 Spathic iron ore, 388.
 Specific gravity, 261.
 heat, 239.
 Specular iron ore, 344.
 Sperryllite, 287, 623.
 Spessartite, 444, 666.
 Sphaerite, 518, 656.
 Sphærocoobaltite, 393, 669.
 Sphalerite, 301, 596, 602, 606, 607, 630, 649.

- Sphene, **503**, 616.
 Sphenoid, **70**.
 orthorhombic, **118**.
 Spinel, **371**, 605, 610, 682.
 group, **371**.
 twins, **143**.
 Splintery, **258**.
 Spodumene, **426**, 605, 675.
 Stalactite, **273**.
 Stalagmite, **273**.
 Staunite, **312**, 629.
 Star of the south diamond, **282**.
 Stassfurtite, **522**.
 Staurolite, **477**, 605, 616, 680.
 Steatite, **500**.
 Stelznerite, **642**.
 Stephanite, **325**, 597.
 Stereocrite, **656**.
 Stereographic projection, **42**.
 Sternbergite, **629**.
 Stibnite, **295**, 597, 623.
 Stillbite, **483**, 602, 670.
 Stilpnomelane, **498**, 659.
 Stokesite, **646**.
 Stolzite, **545**, 649.
 Straight extinction, **187**.
 Streak, **274**.
 Stream tin, **349**.
 Strengite, **510**, 654.
 Striations, **137**, **266**.
 Stromeyerite, **301**, 629.
 Strontianite, **396**, 602, 660.
 Structural formula, **227**.
 Struvite, **118**, 656.
 Styloctypite, **623**.
 Subconchoidal fracture, **258**.
 Sublimates, **7**, 557.
 Sulpharsenates, **323**.
 Sulphates, **236**.
 Sulphides, **232**, **294**.
 Sulpho acids, **232**, **320**.
 Sulphohalite, **638**.
 Sulphur, **285**, 587, 601, 606, 640.
 Sulvanite, **629**.
 Supplementary forms, **27**.
 twins, **140**.
 Surfaces of crystals, **266**.
 Sussexite, **664**.
 Svabite, **653**.
 Svanbergite, **655**.
 Swallow-tail twins, **536**.
 Sylvanite, **626**.
 Sylvite, **328**, 600, 639.
 Symmetry, **13**.
 alternating, **15**.
 axes of, **13**, **15**.
 center of, **13**.
 planes of, **13**.
 pseudo-, **146**.
 Synadelphite, **652**.
 Syngenite, **638**, **662**.
 System, cubic, **47**.
 hexagonal, **84**.
 monoclinic, **120**.
 orthorhombic, **123**.
 tetragonal, **65**.
 triclinic, **129**.
 two-component, **240**.
 Szaibelyite, **664**.
- T**
- Table, for blowpipe determination, **617**.
 of rock-forming minerals, **609**.
 for determination of common minerals, **596**.
 of coats on coal, **593**.
 for fusibility, **555**.
 Tabular habit, **265**.
 Taehydrate, **639**.
 Tagilite, **644**.
 Tale, **500**, 601, 614, 663, 679.
 Tantalates, **236**.
 Tantalite, **506**, **635**.
 Tantalum, **571**.
 Tapalpite, **626**.
 Tapiolite, **635**.
 Tarnish, **275**.
 Taste, **618**.
 Tavistokite, **655**.
 Taylorite, **638**.
 Tellurates, **236**.
 Tellurium, **587**, **626**.
 Tenacity, **258**.
 Tennantite, **324**, **621**.
 Tenorite, **340**.
 Tephroite, **451**, **665**.
 Terlinguaite, **641**.
 Tesseral central, **59**.
 holoaxial, **61**.
 polar, **62**.
 Tetartoehedral forms, **27**.
 Tetradyomite, **625**.
 Tetragonal alternating, **76**.
 axial ratio, **82**.
 axis, **14**.
 equatorial, **72**.
 hemihedral, **72**.
 holoaxial, **75**.
 holohedral, **65**.
 holosymmetric, **65**.
 polar, **78**.
 prism, **67**.
 1st order, **67**.
 2d order, **68**.
 3d order, **74**.
 pyramid, **66**.
 1st order, **66**.
 2d order, **67**.
 3d order, **73**.
 scalenoehedron, **69**.

- Tetragonal system, *16, 65.*
 trapezohedron, *75.*
 trisoctahedron, *50.*
 tristetrahedron, *57.*
 Tetrahedrite, **324**, 596, 597.
 Tetrahedron, *57.*
 tetragonal tris-, *57.*
 trigonal tris-, *56.*
 hex-, *55.*
 Tetrahexahedron, *49.*
 Thallium, tests, *577.*
 Thaumassite, *661.*
 Thenardite, **527**, 638.
 Thermonatrite, *639.*
 Thin sections colors, *216.*
 Third order of colors, *184.*
 Thirty-two types of crystals, *6, 47.*
 Thomsenolite, *663.*
 Thomsonite, **487**, 673.
 Thorite, **457**, 679, 681.
 Thorium, tests, *572.*
 Thoulet's solution, **263.**
 Thulite, **465.**
 Thuringite, *658.*
 Tiemannite, *627.*
 Tiger-eye, **435.**
 Tilasite, *653.*
 Tile ore, **338.**
 Tin, *584, 632.*
 Tincal, **523.**
 Tinstone, **348.**
 Titanates, **233.**
 Titanic iron ore, **346.**
 Titanite, **503**, 603, 616, 667.
 Titanium, tests, *569.*
 oxides, **351.**
 Topaz, **458**, 605, 681.
 false, **359.**
 oriental, **342.**
 Topazolite, **444.**
 Topic parameters, **228.**
 Torbernite, **519**, 644.
 Torrensitite, *667.*
 Total reflection, *167.*
 reflectometer, *211.*
 Touchstone, **361.**
 Tough, **257, 258.**
 Tourmaline, *105, 473, 605, 612, 664.*
 sections of, *177.*
 tongs, *178.*
 Translucency, **275.**
 Transparent, **275.**
 Trapezohedron, hexagonal, *96.*
 tetragonal, *75.*
 trigonal, *109.*
 Tremolite, **431**, 677.
 Trichalcite, *643.*
 Triclinic system, *17, 129.*
 Tridymite, **361**, 611, 681.
 Trigonal axis, *14,*
 equatorial, *105.*
 Trigonal holoaxial, *108.*
 polar, *110.*
 prisms, *103, 106.*
 pyramids, *102, 106.*
 trapezohedron, *109.*
 trisoctahedron, *50.*
 tristetrahedron, *56.*
 Trimerite, *666.*
 Trimorphism, **220.**
 Triphylite, *653.*
 Triplite, *654.*
 Triploidite, *654.*
 Tripolite, **371.**
 Tripuyite, *651.*
 Trisilicates, **234.**
 Trisilicic acid, **234.**
 Tritomite, *666.*
 Trögerite, *652.*
 Troilite, **308**, 630.
 Trona, **401**, 600, 639.
 Troostite, **452.**
 Truncation, *22.*
 Tscheffkinitite, *667.*
 Tschermigite, *638.*
 Tungstates, **236.**
 Tungsten, *587.*
 Tungstite, *668.*
 Turgite, **363**, 633, 658.
 Turingite, **498.**
 Turkey fat, **307, 392.**
 Turner's flux, *559.*
 Turquoise, *3, 510, 518, 604.*
 Twin axis, *138.*
 Brazilian, *146.*
 crystals, *138.*
 interpenetrating, *141.*
 lamellæ, *142.*
 plane, *138.*
 reflection, *140.*
 rotation, *138.*
 spinel, *143.*
 stræ, *142.*
 supplementary, *140.*
 Twinning, *138.*
 lamellæ, *142,*
 polysynthetic, *142.*
 Twins, *137.*
 Tychite, *661.*
 Tyrolite, *643.*
 Tysonite, *679.*
- U
- Ulexite, **524**, 601, 663.
 Ullmannite, **316**, 625.
 Umangite, *627.*
 Uniaxial crystals, *170, 184.*
 interference figure, *191.*
 Unit form, *23.*
 Uralite, **435.**
 Uralitization, **426.**

Uranates, **236, 507**.
 Uraninite, **525, 596, 608, 634**.
 Uranium, tests, **576**.
 Uranocircite, **655**.
 Uranophane, **669**.
 Uranophilite, **669**.
 Uranospinite, **653**.
 Uranothallite, **661**.
 Utahite, **636**.
 Uvarovite, **445, 669**.

V

Valentinite, **346, 641**.
 Vanadates, **236**.
 Vanadinite, *95*, **512, 648**.
 Vanadium, tests, **576**.
 Variscite, **510, 519, 656**.
 Vauquelite, **644**.
 Verdi antique, **499**.
 Vermiculite, **670**.
 Vesuvianite, **455, 605, 611, 676**.
 Veszelyite, **642**.
 Vibrations plane, *176*.
 Vicinal faces, **267**.
 Viluite, **455**.
 Vitreous luster, **279**.
 Vivianite, **510, 516, 608, 654**.
 Volatilization, **552**.
 Volborthite, **645**.
 Voltaite, **636**.

W

Wad, **368, 667**.
 Wagnerite, **657**.
 Walpurgite, **650**.
 Warwickite, **665**.
 Water, **225, 240, 337, 557**.
 of constitution, **226**.
 of crystallization, **225**.
 Wave direction, *161*.
 front, *161*.
 length, *162*.
 surface, *169*.
 Wavellite, **510, 518, 602, 656**.
 Waves of light, *161*.
 Waxy luster, **279**.
 Wellsite, **479, 670**.
 Wernerite, **453, 603, 674, 676**.
 Westphal balance, **264**.

Whattevellite, **662**.
 Wheel ore, **321**.
 Whitneyite, **621**.
 Willemite, *99*, **451, 603, 649**.
 Witherite, **395, 602, 660**.
 Wittichenite, **628**.
 Wöhlerite, **669**.
 Wolfachite, **622**.
 Wolfram (Tungsten), **586**.
 Wolframite, **542, 596, 633, 659**.
 Wolframum, tests, **587**.
 Wollastonite, **429, 603, 675**.
 Wood opal, **370**.
 Wulfenite, *78*, **545, 602, 648**.
 Wurtzite, *93*, **303**.

X

Xanthoconite, **645**.
 Xanthophilite, **678**.
 Xanthosiderite, **658**.
 Xenotime, **657**.

Y

Ytterbium, **572**.
 Yttrium, tests, **572**.
 Ytrocrite, **678**.
 Yttrotantalite, **635**.

Z

Zaratite, **669**.
 Zeolites, **478, 479, 613**.
 Zepharovichite, **656**.
 Zeunerite, **520, 643**.
 Zinc, **631**.
 tests, **573**.
 Zinc blende, **301**.
 Zincite, **339, 606, 650**.
 Zinkenite, **320**.
 Zinnwaldite, **488, 496**.
 Zircon, **456, 605, 612, 682**.
 Zirconium, tests, **571**.
 Zirkelite, **668**.
 Zoisite, **465, 674, 676**.
 Zone, *22*.
 axis, *22*.
 circle, *43*.
 law, *22*.
 Zunyite, **680**.



THE following pages contain advertisements of books of kindred interest, or on related subjects.

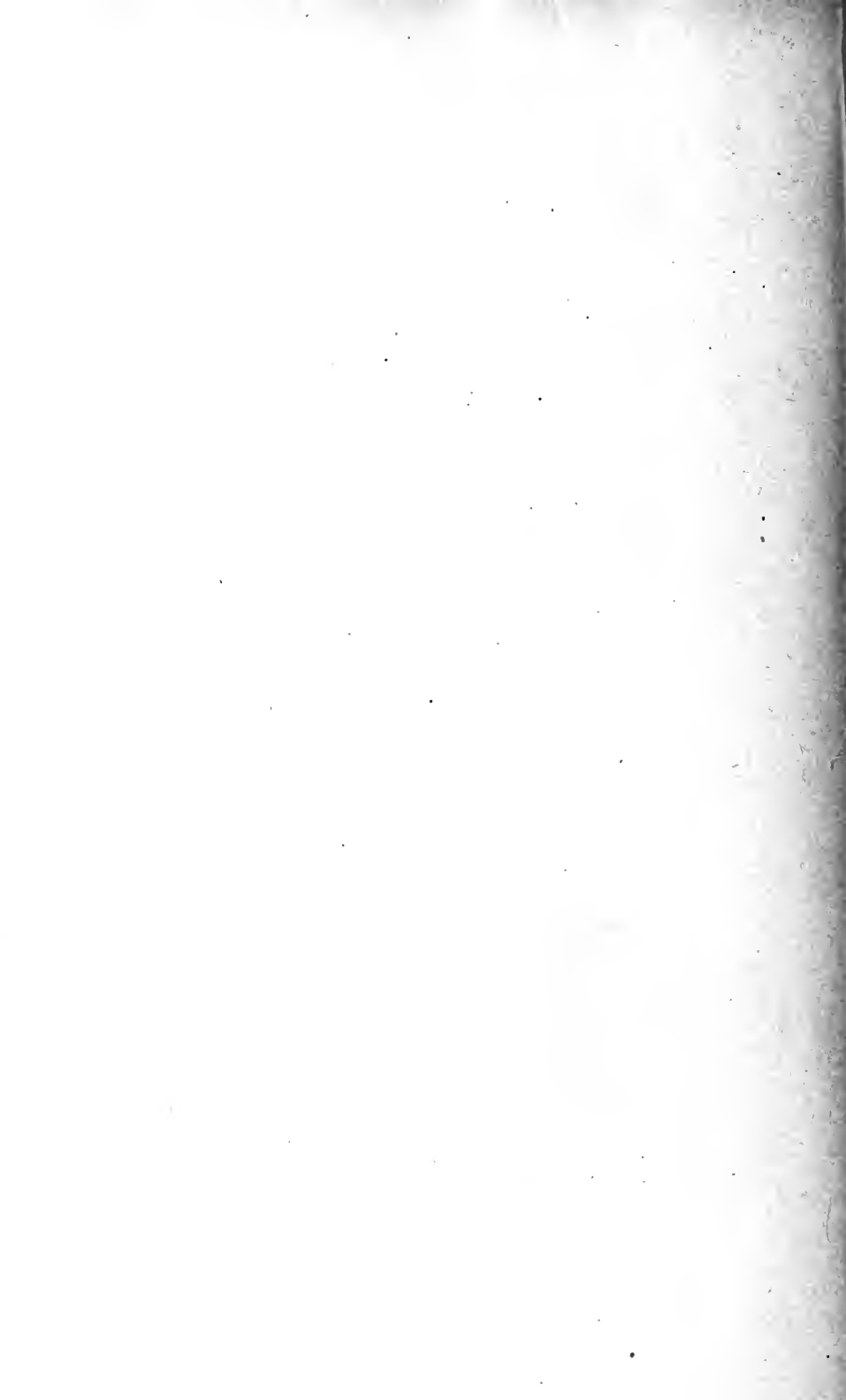

Economic Geology

WITH SPECIAL REFERENCE TO THE UNITED STATES

By HEINRICH RIES, A.M., Ph.D.,

Professor of Economic Geology at Cornell University

*Third Edition, enlarged and thoroughly revised, 589 pages
237 illustrations, 56 plates, \$3.50 net; by mail, \$3.70*

"Altogether the work is an admirable one, and we strongly commend it to teachers in this country as a source of concise, accurate, and recent information regarding the mineral deposits of the United States." — *Nature*, London.

"All general introductory geological or mineralogical matter, the reader is supposed to have acquired. For less important matter slightly smaller type is used. The style is condensed to the last degree, but not at the expense of its clearness, which is French. The result is a compact and excellent book—one that every broad-minded business man should have, and that deserves the wide acceptance which it is finding." — *Science*.

"Necessarily condensed, it yet covers the ground in a thorough and authoritative manner and will be used by many as the most satisfactory textbook available." — H. V. W. in *The American Geologist*.

"The author is to be congratulated on the broad perspective he has of his theme, and the clearness of his style in presenting it. He uses no unnecessary words in his treatise; he omits none that are requisite to its complete presentation.

"It is to the economic phase of geological study that he addresses himself. What the commercial value and uses of the various deposits in the earth's crusts are, he tells us in the plainest and most forcible way. He does not entirely avoid other features of geology which have been presented in many other volumes, but he holds himself to the one purpose of showing the industrial and commercial value of clays, and coals, and marbles, and metallic ores. To all those who are interested in mines, and in manufacturing what mines produce, his work cannot fail to be of the highest value.

"The book is divided into two sections: the first dealing with 'Non-Metallic Minerals'—such as coals, petroleum, building stones, cements, gypsum, and others; and the second part treating of 'Metallic Minerals or Ores'—such as iron, copper, lead, zinc, aluminum, and many others. The ground covered by the author is very comprehensive and thorough.

"The illustrations and diagrams are numerous and illuminative. The author has had access to plates and cuts of the United States Geological Survey in many instances, and has made use of the statistical tables from the same source. Taken all together, the volume is among the choicest of its kind, and we predict for it a wide circulation." — *New England Journal of Education*.

THE MACMILLAN COMPANY

Publishers

64-66 Fifth Avenue

New York

Economic Geology of the United States

WITH BRIEFER MENTION OF FOREIGN MINERAL PRODUCTS

By RALPH S. TARR, B.S., F.G.S.A.,
Assistant Professor of Geology at Cornell University

Second Edition Revised \$ 3.50 net

COMMENTS

"I am more than pleased with your new 'Economic Geology of the United States.' An introduction to this subject, fully abreast of its recent progress, and especially adapted to American students and readers, has been a *desideratum*. The book is admirably suited for class use, and I shall adopt it as the text-book for instruction in Economic Geology in Colorado College. It is essentially accurate, while written in a pleasant and popular style, and is one of the few books on practical geology that the general public is sure to pronounce *readable*. The large share of attention given to non-metallic resources is an especially valuable feature." — FRANCIS W. CRAGIN, *Professor of Geology, Mineralogy, and Paleontology at Colorado College*.

"I have examined Professor R. S. Tarr's 'Economic Geology' with much pleasure. It fills a felt want. It will be found not only very helpful to students and teachers by furnishing the fundamental facts of the science, but it places within easy reach of the business man, the capitalist, and the statesman, fresh, reliable, and complete statistics of our national resources. The numerous tables bringing out in an analytic way the comparative resources and productiveness of our country and of different states, are a specially convenient and admirable feature. The work is an interesting demonstration of the great public importance of the science of geology." — JAMES E. TODD, *State Geologist, South Dakota*.

"It is one of those books that is valuable for what it omits, and for the concise method of presenting its data. The American engineer has now the ability to acquire the latest knowledge of the theories, locations, and statistics of the leading American ore bodies at a glance. Were my course one of text-books, I should certainly use it, and I have already called the attention of my students to its value as a book of reference." — EDWARD H. WILLIAMS, *Professor of Mining, Engineering, and Geology at Lehigh University*.

"I have taken time for a careful examination of the work; and it gives me pleasure to say that it is very satisfactory. Regarded simply as a general treatise on Economic Geology, it is a distinct advance on anything that we had before; while in its relations to the Economic deposits of this country it is almost a new creation and certainly supplies a want long and keenly felt by both teachers and general students. Its appearance was most timely in my case, and my class in Economic Geology are already using it as a text-book." — WILLIAM O. CROSBY, *Assistant Professor of Structural and Economic Geology at the Massachusetts Institute of Technology*.

THE MACMILLAN COMPANY

Publishers

64-66 Fifth Avenue

New York

The Natural History of Igneous Rocks

BY ALFRED HARKER

Illustrated, cloth, 8vo, \$3.00 net

A BRIEF SUMMARY OF CONTENTS

Igneous Action in Relation to Geology — Vulcanicity — Igneous Intrusion — Petrographical Provinces — Mutual Relations of Associated Igneous Rocks — Igneous Rocks and Their Constituents — Rock Magmas — Crystallization of Rock Magmas — Supersaturation and Deferred Crystallization — Isomorphism and Mixed Crystals — Structures of Igneous Rocks — Mineralizers and Pneumatolysis — Magmatic Differentiation — Hybridism in Igneous Rocks — Classification of Igneous Rocks.

Rocks, Rock-weathering, and Soils

BY GEORGE P. MERRILL

Curator of Department of Geology, United States National Museum, and Professor of Geology in the Corcoran Scientific School, etc.

*With many Illustrations Full-page Plates and Figures in the Text
Second Edition Cloth 8vo Price \$1.00 net*

"This is one of the most useful and most satisfactory manuals that has appeared in recent years, possessing as much interest for the geographer as for the geologist." — *Bulletin Amer. Geog. Society.*

"In treatment, as in subject, Professor Merrill's work is notable. It is strictly up to date, embracing the results of the latest researches, and duly recognizing the work of contemporary investigators; also it is made admirable mechanically by clear typography, good paper, excellent illustrations, and a full index." — *National Geographic Magazine.*

"A book brimful of facts obtained by workers in divers fields. The work forms a highly important addition to our practical knowledge of geology." — *Scientific American.*

THE MACMILLAN COMPANY

Publishers

64-66 Fifth Avenue

New York

An Introduction to Geology

By WILLIAM B. SCOTT

Illustrated, cloth, 12mo, \$2.60 net

An introduction to the science of geology for both students who desire to pursue the subject exhaustively and those who wish merely to obtain an outline of the methods and principal results of the science. This is not one of the text-books which always pronounces a definite and final opinion. The author holds that in no science are there more open questions than in geology; in none are changes of view more frequent; and in none is it more important to emphasize the distinction between fact and inference. The student is here encouraged to weigh evidence and balance possibilities and to suspend judgment when the testimony is insufficient to justify decision. The author is an advocate of the new geology, and his book presents all the latest advances in the science. The book is very fully illustrated, many of the plates being from photographs taken by the United States Geological Survey.

"I have looked the book through with increasing pleasure. The latest advances in American geology have been taken advantage of, so that the book is up to date. American instructors have been waiting a long time for a book which could be used satisfactorily as a guide in an opening course in geology. Professor Scott's book seems to me to be admirably adapted for this purpose." — Professor C. R. VAN HISE, University of Wisconsin.

"Professor Scott's Geology seems to me excellently fitted for my beginners at Smith College, and I shall try it there next year. It is a fine book." — Professor B. K. EMERSON, Amherst College.

THE MACMILLAN COMPANY

Publishers 64-66 Fifth Avenue New York

"THIS BOOK TAKES HIGH RANK AMONG THE FEW GREAT BOOKS UPON GLACIERS."

Characteristics of Existing Glaciers

BY WILLIAM HERBERT HOBBS

Professor of Geology, University of Michigan

Illustrated, cloth, 8vo, \$3.25 net ; by mail, \$3.47

"The author has done good service to the glaciologist and glacial geologist in bringing together his concise description and classification of existing glaciers and ice-sheets in the present convenient form. Especially in the parts devoted to Arctic and Antarctic ice he has made an exhaustive digest of the scattered literature, and has presented a copiously illustrated summary of the available information respecting the distribution and character of the ice of these regions. To the end of each chapter he appends a full list of his authorities, so that the book is in every respect a most useful work of reference. . . . Every geographer and geologist interested in ice will appreciate these clear descriptions and excellent illustrations of the earth's great glaciers — they make up into a most presentable book." — *Nature*.

BY THE SAME AUTHOR

Earth Features and their Meaning

Profusely Illustrated, 8vo, \$3.00 net

"The book is an excellent reference volume for students who are interested in a simple outline of geology. The volume has been tested in class work and should prove its worth." — *Bulletin of American Geographical Society*.

THE MACMILLAN COMPANY

Publishers

64-66 Fifth Avenue

New York

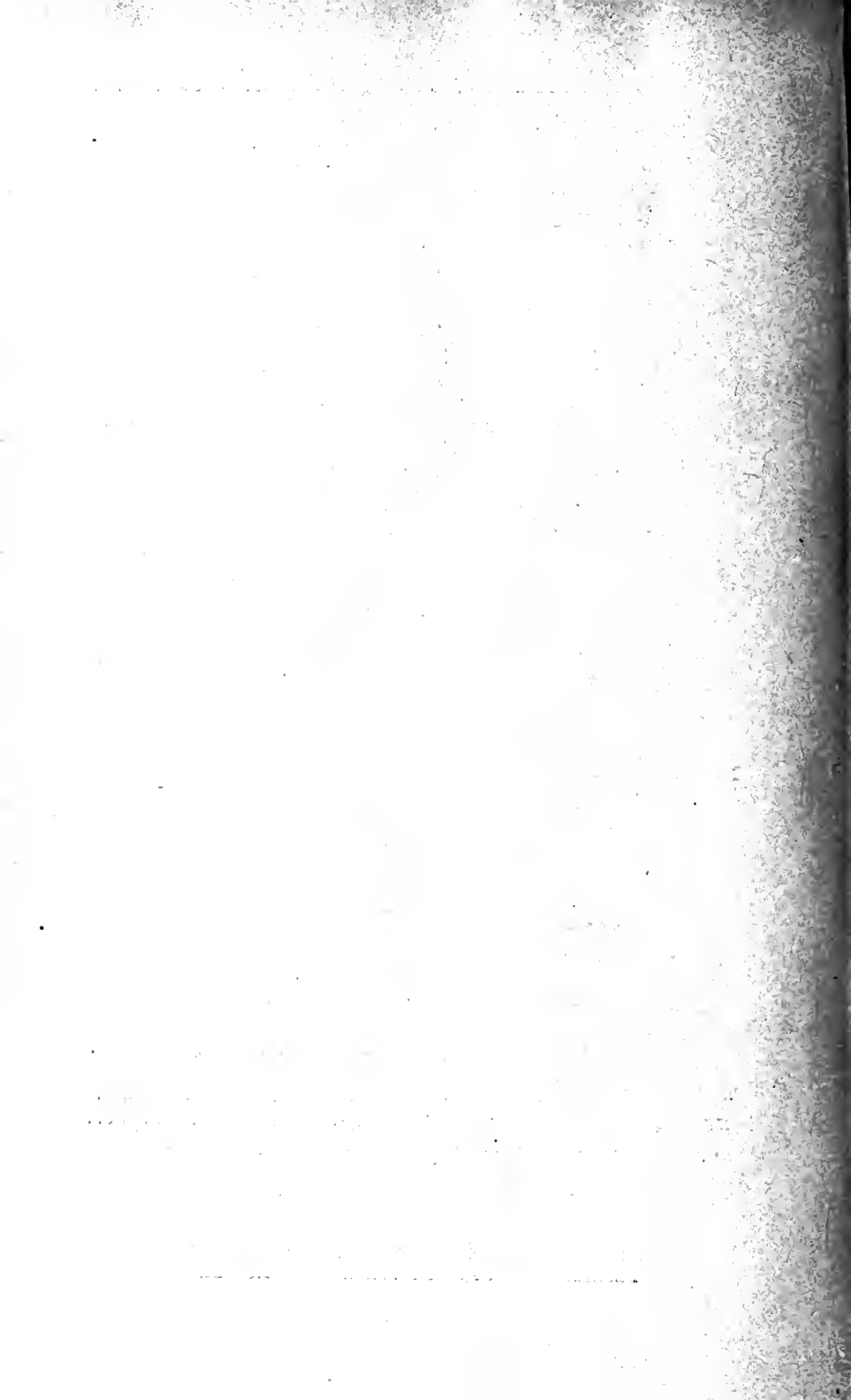



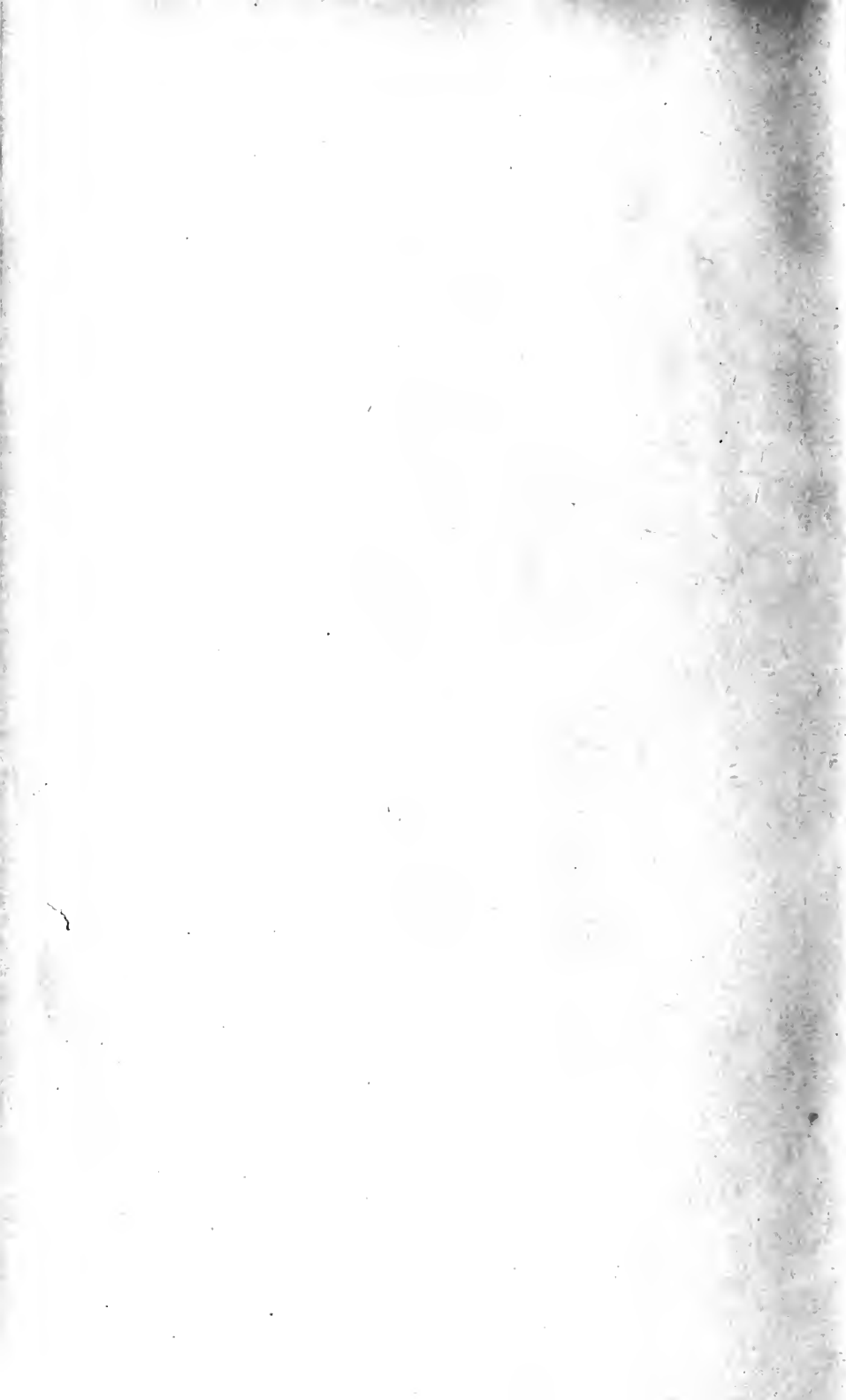

PLEASE DO NOT REMOVE
CARDS OR SLIPS FROM THIS POCKET

UNIVERSITY OF TORONTO LIBRARY

S&M

A

54

