

Annals
of the
Missouri
Botanical
Garden
2009



Volume 96
Number 1

The Annals, published quarterly, contains papers, primarily in systematic botany, contributed from the Missouri Botanical Garden, St. Louis. Papers originating outside the Garden will also be accepted. All manuscripts are peer-reviewed by qualified, independent reviewers. Authors should write the Managing Editor for information concerning arrangements for publishing in the *Annals*. Instructions to Authors are printed in the back of the last issue of each volume and are also available online at www.mbgpress.org.

Editorial Committee

Victoria C. Hollowell
Scientific Editor,
Missouri Botanical Garden

Beth Parada
Managing Editor,
Missouri Botanical Garden

Allison M. Brock
Associate Editor,
Missouri Botanical Garden

Tammy Charron
Editorial Assistant,
Missouri Botanical Garden

Cirri Moran
Press Coordinator,
Missouri Botanical Garden

Roy E. Gereau
Latin Editor,
Missouri Botanical Garden

Ihsan A. Al-Shehbaz
Missouri Botanical Garden

Gerrit Davidse
Missouri Botanical Garden

Peter Goldblatt
Missouri Botanical Garden

Gordon McPherson
Missouri Botanical Garden

Charlotte Taylor
Missouri Botanical Garden

Henk van der Werff
Missouri Botanical Garden

For subscription information contact ANNALS OF THE MISSOURI BOTANICAL GARDEN, % Allen Marketing & Management, P.O. Box 1897, Lawrence, KS 66044-8897. Subscription price for 2009 is \$175 per volume U.S., \$185 Canada & Mexico, \$210 all other countries. Four issues per volume. The journal *Novon* is included in the subscription price of the *Annals*.

annals@mobot.org (editorial queries)

<http://www.mbgpress.org>

The *Annals* are abstracted and/or indexed in AGRICOLA (through 1994), APT Online, BIOSIS®, CAB Abstract/Global Health databases, ingenta, ISI® databases, JSTOR, Research Alert®, and Sci Search®.

The full-text of ANNALS OF THE MISSOURI BOTANICAL GARDEN is available online through BioOne™ (<http://www.bioone.org>).

© Missouri Botanical Garden Press 2009

The mission of the Missouri Botanical Garden is to discover and share knowledge about plants and their environment, in order to preserve and enrich life.

THE ANNALS OF THE MISSOURI BOTANICAL GARDEN (ISSN 0026-6493) is published quarterly by the Missouri Botanical Garden, 2345 Tower Grove Avenue, St. Louis, MO 63110. Periodicals postage paid at St. Louis, MO and additional mailing offices. POSTMASTER: Send address changes to ANNALS OF THE MISSOURI BOTANICAL GARDEN, % Allen Marketing & Management, P.O. Box 1897, Lawrence, KS 66044-8897.

Volume 96
Number 1
2009

Annals
of the
Missouri
Botanical
Garden



THIRD INTERNATIONAL
RUBIACEAE CONFERENCE:
INTRODUCTION¹

*Petra De Block,² Charlotte M. Taylor,³ and
Suzy Huysmans⁴*

The family Rubiaceae is the fourth largest family of flowering plants in terms of the number of species known, with worldwide distribution, but most of its diversity is concentrated in the highly threatened and rapidly disappearing moist ecosystems of tropical and subtropical regions. Rubiaceae are badly in need of study by systematists, ecologists, and conservationists at a basic level, and their important role in these tropical ecosystems together with the active threat to the existence of so many species adds urgency to this work. The pace and intensity of this research are significantly increased by conferences specifically targeting this family.

The First International Rubiaceae Conference, held at the Missouri Botanical Garden in St. Louis in 1993, brought together students of Paleotropical and Neotropical groups for the first time; selected proceedings were published in 1995 in the *Annals of the Missouri*

Botanical Garden (volume 82, issue 3, pp. 355–439). The Second International Rubiaceae Conference, held at the National Botanic Garden of Belgium in Meise in 1995, focused on Rubiaceae as part of the Gentianales (then a fairly new consensus classification for the family) and delimitation of subfamilies and problematic tribal and generic complexes; the full proceedings were published in 1996 in *Opera Botanica Belgica* (volume 7, pp. 1–432). For more than 10 years after that, no meeting was held until 2005, when a half-day symposium focused on Rubiaceae during the XVII International Botanical Congress in Vienna (no proceedings were published). This symposium clearly showed interest in and need for a longer meeting.

The Third International Rubiaceae Conference was subsequently co-organized by the Katholieke Uni-

¹The editors of these proceedings express their gratitude to Victoria C. Hollowell, scientific editor and head of Missouri Botanical Garden Press; Beth Parada, managing editor; and Allison Brock, associate editor, for their collaboration in publishing the proceedings of the Third International Rubiaceae Conference in the *Annals of the Missouri Botanical Garden*. We thank additional members of the organizing and scientific committees for their help in organizing a successful conference: Birgitta Bremer, Helga Ochoterena, Elmar Robbrecht, Erik Smets, and Steven Dessein. The National Botanic Garden of Belgium is acknowledged for publishing the Programme and Abstracts book (*Scripta Bot. Belg.* 40). We thank the staff and students of the Laboratory of Plant Systematics, Katholieke Universiteit Leuven, for their enthusiastic assistance and hospitality during the conference. We are grateful to the authors and reviewers for their help in getting the papers in this volume published and acknowledge the following organizations for sponsoring the Third International Rubiaceae Conference: Research Foundation–Flanders (FWO), the Systematics Association, the National Botanic Garden of Belgium, Easyware Leuven, and the National Lottery Belgium.

²National Botanic Garden of Belgium, Domein van Bouchout BE-1860 Meise, Belgium. deblock@br.fgov.be.

³Missouri Botanical Garden, P.O. Box 299, St. Louis, Missouri 63166, U.S.A. charlotte.taylor@mobot.org.

⁴Laboratory of Plant Systematics, Katholieke Universiteit Leuven, Kasteelpark Arenberg 31, P.O. Box 2437, BE-3001 Leuven, Belgium. suzy.huysmans@bio.kuleuven.be.

doi: 10.3417/2008118

versiteit Leuven and the National Botanic Garden of Belgium from 18 to 21 September 2006 (De Block et al., 2006) and held in Leuven. The conference aimed to provide a forum for all Rubiaceae and Gentianales researchers to present results achieved in the decade since the second conference, and a venue for discussions and networking. Six themes were scheduled: systematics at the family level, systematics at the subfamily and tribal level, biogeography of Rubiaceae, studies of other members of the Gentianales and the order as a whole, studies of particular genera, and Rubiaceae checklists. In addition, two keynote lectures reviewed very different but interconnected subjects. The present volume groups the two keynote lectures and 10 other presentations from this congress.

From the first keynote lecture (in order of presentation at the congress), Graham reviews the fossil record for Rubiaceae in detail, covering fossils of 125 taxa attributed to the family from deposits as old as the Late Cretaceous and Paleocene; this review concludes that the oldest “dependable” fossils (i.e., those useful for dating phylogenies) are from the middle and late Eocene and represent *Emmenopterys* Oliv., *Faramea* Aubl., *Guettarda* L., and *Canthium* Lam. From the other keynote lecture, Bremer here gives a historical overview of 15 years of molecular phylogenetic studies of Rubiaceae, covering a period that saw tremendous advances in our understanding of the phylogeny of the family.

The sessions addressing studies of the family, tribal, and genus levels were dominated by molecular contributions, but did include a few studies of morphological and chemical characters. This reflects the general recent trend in systematic work, lamented by some and applauded by others. This trend is clearly evident in the present volume, which includes nine papers from these sessions.

Addressing the tribal level, Razafimandimbison et al. provide new insights into the phylogeny of the large Paleotropical tribe Vanguerieae. Focusing on the dioecious taxa within this tribe, their results point to a single origin of functional dioecy from hermaphroditism followed by subsequent reversals back to the hermaphroditic condition in certain genera. Here also, Cortés-B. et al. confirm the monophyly of the Neotropical genus *Retiniphyllum* Bonpl., its placement in the monotypic tribe Retiniphyllae, and that this tribe is sister to the core members of subfamily Ixoroideae (i.e., tribes Coffeae, Gardenieae, Ixoreae, Octotropideae, Pavetteae, and Vanguerieae). Also, Delprete discusses the taxonomic history, phylogenetic evidence, and reproductive biology of the Neotropical tribe Posoquerieae, and cites their unusual pollen catapult mechanism as the character-

istic feature of both genera of this recently described tribe.

Addressing problems originally confined within tribes but that finally require tribal readjustments, Mouly et al. present a molecular phylogenetic analysis of the species-rich pantropical genus *Ixora* L., which they show to be polyphyletic. Broadening the circumscription of *Ixora* accordingly to encompass additional species also necessitates a redelimitation of the tribe Ixoreae, for which these authors adopt a narrow circumscription and describe two new tribes, Aleisantheae of Indomalaysia and Greeneae of Southeast Asia. Also, Rova et al. present a molecular phylogeny of the large, morphologically variable Neotropical genus *Rondeletia* L., which they show to be polyphyletic. Delimiting monophyletic groups within this traditionally circumscribed genus leads the authors to divide *Rondeletia* s.l. and propose new delimitations of the tribes Rondeletieae and Guettardeae.

Considering problems that lie within tribes, Groeninckx et al. address the phylogenetic relationships within the herbaceous tribe Spermaceae s.l. based on a broad sampling across the major lineages of this tribe. Along with some delimitations of problematic groups for future study, these authors stress the need for morphological data to support clades and relationships found in molecular analyses. Here also, Martínez-Cabrera et al. document the variation in leaf and petiole anatomical characters and evaluate their phylogenetic value within the Neotropical tribe Hamelieae.

Considering individual genera, Tosh et al. present a phylogenetic study of the Afro-Malagasy genus *Tricalysia* A. Rich. (Coffeae) and conclude that its subgenus *Tricalysia* and subgenus *Empogona* (Hook. f.) Robbrecht do not form a monophyletic clade, leading them to restrict the genus circumscription to subgenus *Tricalysia* and return subgenus *Empogona* to generic rank. Here also, Cabral presents a revision of the Neotropical genus *Galianthe* Griseb., which comprises 39 species in two sections, with section *Laxae* E. L. Cabral newly described here.

Last but not least, Davis et al. analyze several aspects of the data available in the Royal Botanic Gardens, Kew World Checklist of Rubiaceae (<<http://apps.kew.org/wcsp//home.do>>). Many workers worldwide, both Rubiaceae specialists and others, regularly use this database for inquiries of synonymy, correct spelling, correct authorship, and place of publication of Rubiaceae names. However, the data compiled here also address distribution, diversity, and endemism of Rubiaceae and show the taxonomic efforts in this family. A notable analysis presented here shows that the number of new Rubiaceae species described each

year oscillates, but has not decreased markedly in recent years. Clearly, much remains to be discovered. Given the threat to many if not most of the species of Rubiaceae by destruction of their habitat, there is no time to waste filling in the gaps in our knowledge of this family. We are called upon to continue and, if possible, intensify our efforts to study the Rubiaceae, and to develop strong collaborations

amongst ourselves as well as with specialists of other disciplines to preserve as much Rubiaceae diversity as possible.

Literature Cited

De Block, P., S. Dessein & E. Robbrecht (editors). 2006. Third International Rubiaceae Conference, Programme and Abstracts. *Scripta Bot. Belg.* 40: 1–92.

A REVIEW OF MOLECULAR PHYLOGENETIC STUDIES OF RUBIACEAE¹

Birgitta Bremer²

ABSTRACT

Rubiaceae is one of the five largest families of flowering plants with over 13,000 species. We have seen a tremendous increase in our understanding of the phylogeny of the family through studies on molecular data during the 15-year period from 1991 to 2005; some new relationships are completely unexpected and different from traditional classification. At the end of 2005, ca. 50 phylogenetic reconstructions from the family had been published based on more than 4400 sequences. Most studies are based on ITS and *rbcL* sequences, but 13 different markers have been used. Most sequences available in GenBank (as of 2005) are from *rps16*, *trn(T)L-F*, *rbcL*, and ITS. We can now see a framework of the family phylogeny with support for three subfamilies and over 43 tribes; subfamily Cinchonoideae (Chiococceae, Cinchoneae, Guettardeae, Hamelieae, Hillieae, Hymenodictyeae, Isertieae, Naucleaeae, Rondeletieae), subfamily Ixoroideae (Alberteae, Bertiereae, Coffeaeae, Condamineaeae, Cremasporeae, Gardenieae, Ixoreae, Mussaendeae, Octotropideae, Pavetteae, Posoquerieae, Retiniphyllaeae, Sabiceaeae, Sipaneeae, Vanguerieae), and subfamily Rubioideae (Anthospermeae, Argostemmataeae, Coussareeae, Craterispermeae, Danaideae, Gaertnereae, Knoxieae, Lasiantheae, Morindeae, Ophiorrhizeae, Paederieae, Psychotrieae, Putorieae, Rubieae, Schradereae, Spermacoceae, Theligoneae, Urophyllaeae), and tribe Coptosapelteae, which is placed outside the three subfamilies. Two of these tribes, Gardenieae and Morindeae, are paraphyletic/polyphyletic. Only about half of the tribes have been the focus of specific investigations. However, we have seen increased interest in using Rubiaceae phylogenies for studies of ecology, evolution, and biogeography, e.g., and also for morphological and anatomical investigations. Evolution of fruit traits, flower types, and myrmecophytism has been investigated, and biogeographic patterns for specific taxa in Africa, the Caribbean, and the Pacific have been studied. In addition, distribution of pollen types, chemical substances, and wood characteristics have been compared with molecular phylogenies.

Key words: Biogeography, classification, ecology, evolution, ITS, morphological characters, phylogeny, *rbcL*, *rps16*, Rubiaceae review, *trn(T)L-F*.

The Rubiaceae family, with more than 13,000 species (Govaerts et al., 2006), has been the subject of many molecular phylogenetic studies during the 15-year period from 1991 to 2005. Here, I review and summarize the main conclusions from these studies. Molecular phylogenetics of Rubiaceae was preceded by a few phylogenetic analyses based on morphology from the late 1970s and early 1990s. In 1979, the first cladogram of *Neurocalyx* Hook. placed the genus in Argostemmataeae (Bremer, 1979); in 1990 the first cladogram of *Xanthophytum* Reinw. ex Blume placed the genus in Hedyotideae (Axelius, 1990). Both phylogenies were published in association with minor generic revisions, and the trees were the result of simple parsimony analyses with few morphological characters. Andersson and Persson (1991) published a very early morphological analysis of tribe Cinchoneae and relatives. Their analysis resulted in a new circumscription of Cinchoneae, a description of the new tribe Calycophylleae, and an emended tribe Coptosapelteae. The Cinchoneae tree has a low

resolution with many odd relationships compared to later molecular analyses (Razafimandimbison & Bremer, 2001, 2002; Rova et al., 2002; Andersson & Antonelli, 2005). The relationships in *Neurocalyx* and *Xanthophytum* have not yet been tested by molecular data, but both genera have been transferred to tribe Ophiorrhizeae based on sequence data (Bremer & Manen, 2000). Very soon after the analyses described above, molecular data (from 1991, see below), or combinations of molecular and morphological data, analyzed with computer programs replaced simple manual morphological analyses. There is no evident difference in quality between morphological and molecular data, but because higher numbers of characters can be produced from DNA, it is easier to get better-supported trees (e.g., Bremer et al., 1999).

During 15 years of molecular phylogenetic analyses of Rubiaceae taxa, from the beginning of 1991 to the end of 2005, ca. 50 studies have been published, which cover many parts of the family and address questions at different taxonomic levels, from closely

¹ I would like to thank Kåre Bremer and Aaron Davis for comments on an earlier draft of this manuscript, and Aaron Davis and Rafaël Govaerts for information about species number in Rubiaceae genera. Additional thanks to Torsten Eriksson for permission to use Figure 1, and the Swedish Research Council and the Knut and Alice Wallenberg Foundation for financial support.

² Bergius Foundation, Royal Swedish Academy of Sciences and Botany Department, Stockholm University, SE-106 91 Stockholm, Sweden. birgitta.bremer@bergianska.se.

doi: 10.3417/2006197

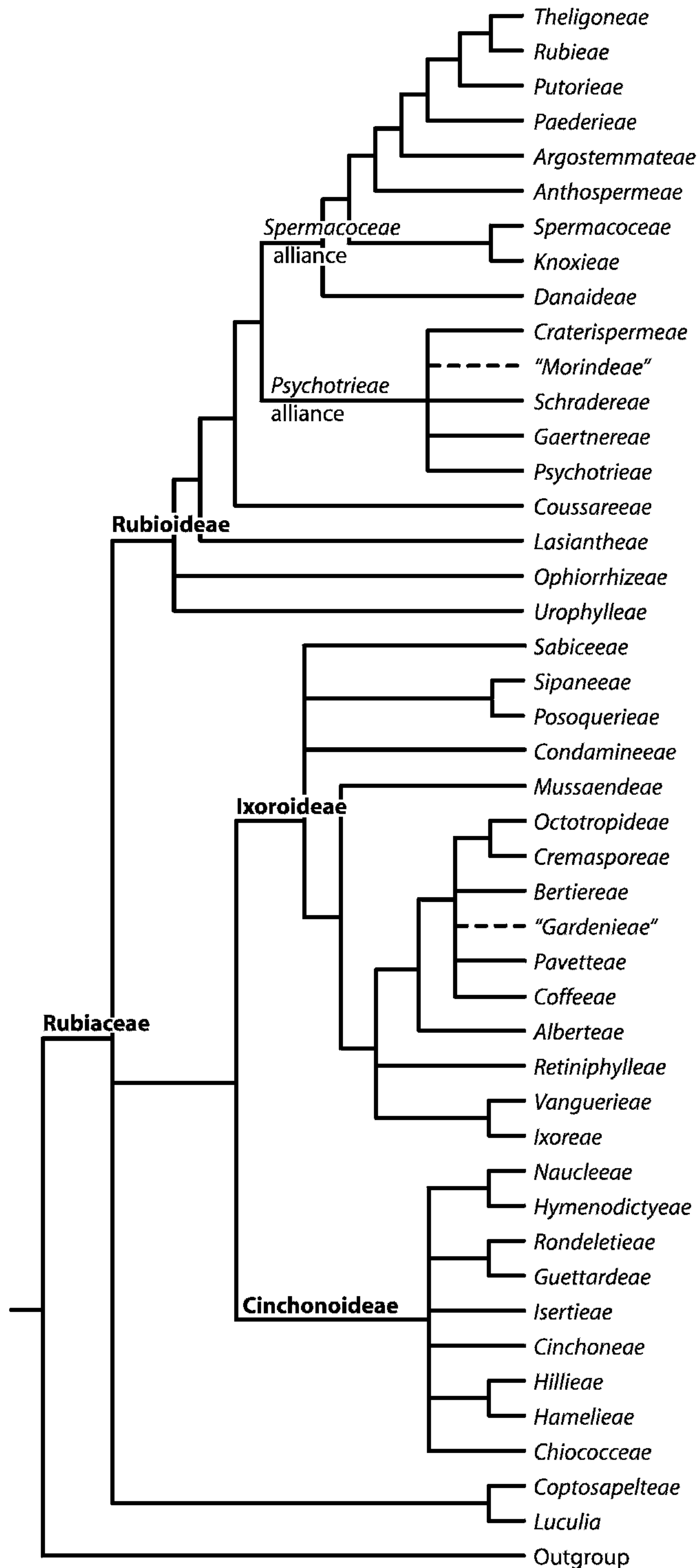

Figure 1. Simplified majority rule consensus tree from MrBayes 3.1.1 analysis, of 538 Rubiaceae taxa and 9420 characters from five chloroplast markers. All resolved nodes and tribes have 0.95 to 1.0 clade credibility (except Guettardeae, with 0.92) and are accepted as monophyletic (Cremasporeae, Retiniphyllae, Schradereae, and Theligoneae are monotypic or represented by single taxa and thus could not be tested for monophyly). Two tribes, Gardenieae and Morindeae, are paraphyletic/polyphyletic. Presented (slightly modified) at the Third International Rubiaceae Conference in Leuven in 2006.

related species to the whole family. Except for the first analysis of restriction site data, all later studies have used sequence data, and the most popular markers (the largest number of studies) have been ITS and *rbcL*. Altogether, 13 different sequence markers have been used, seven from chloroplast DNA (cpDNA) (*atpB-rbcL*, *ndhF*, *matK*, *rbcL*, *rps16*, *trn(T)L-F*, *trnS-G*) and six nuclear DNA (ETS, ITS, nontranscribed spacer [NTS], *pep-C* large, *pep-V* small, *Tpi*). At the end of 2005, more than 4400 sequences from the family were available from GenBank/European Molecular Biology Laboratory (EMBL) (excluding the double number of *Coffea* L. sequences produced for purposes other than phylogenetics). Of these 4400, most sequences are from *rps16* (719), *trn(T)L-F* (672), *rbcL* (643), and ITS (323). In the future, we will see many more markers used in Rubiaceae, but of the 13 that have been used so far, many are underexplored (e.g., *matK* and *ndhF* for higher taxonomic levels and ETS and NTS for more closely related taxa).

This paper is divided into two main parts. The first part focuses on phylogenetic reconstructions, studies covering the whole family, studies sorted under the three subfamily headings, first tribal studies, and finally genera studies. I have tried to discuss them in chronological order according to the first molecular study of the specific group. Some studies have been difficult to classify according to taxonomic level unless the author(s) had indicated a focus on a specific rank. Studies including substantially new data, not just reanalyzed data sets, have been considered. The second part of this review is a presentation of studies in which a Rubiaceae phylogeny has been used to ask other questions about the family, concerning, e.g., ecology, evolution, biogeography, anatomy/morphology, or chemistry. To assist the reader in navigating among all subfamilial and tribal names, I refer to a phylogeny and classification (Fig. 1) presented at the Third International Rubiaceae Conference in Leuven in 2006 (Bremer & Eriksson, unpublished data). In the tree, three subfamilies and 43 tribes are well supported (all resolved nodes and tribes have 0.95 to 1.0 clade credibility, except Guettardeae, with 0.92; the Bayesian analysis is based on 538 taxa for five molecular markers) and accepted as monophyletic (Cremasporae, Retiniphyllae, Schradereae, and Theligoneae are monotypic or represented by single taxa and thus could not be tested for monophyly), and two tribes, Gardenieae and Morindeae, are paraphyletic/polyphyletic. Representatives from all 43 of these tribes have been included in some of the analyses, but only 16 tribes have been the focus of specific studies. All genera discussed are listed in Table 1.

PHYLOGENETIC RECONSTRUCTIONS

FAMILY RUBIACEAE

The first attempt to reconstruct the Rubiaceae phylogeny based on molecular data was published in 1991 by Bremer and Jansen in the *American Journal of Botany*. The data were from restriction site mapping of cpDNA. Included were 161 informative characters for 33 taxa and genera representing 17 different tribes. Unfortunately, no external outgroup was incorporated, which affected the rooting of the family. Several relationships suggested in earlier classifications by Bremekamp (1954, 1966), Verdcourt (1958), Bridson and Verdcourt (1988), and Robbrecht (1988) were corroborated, but many new relationships disagreeing with earlier classifications were also proposed. The subfamily Rubioideae of Verdcourt (1958) was mostly monophyletic (including the tribes Rubieae, Anthospermeae, Coccocypseae, Hedyotideae, Psychotrieae, but excluding Hamelieae [*Hamelia* Jacq., *Hoffmannia* Sw.] and Ixoroideae fide Robbrecht [1988; including Coffeae, Gardenieae, Pavetteae, and Vanguerieae but not Chiococceae]). Several taxa earlier classified to Cinchonoideae (e.g., *Calycophyllum* DC., *Mussaenda* L., *Pinckneya* Michx., and *Pogonopus* Klotzsch) were shown to be closer to the subfamily Ixoroideae. It was also shown that the recircumscribed Antirheoideae (Robbrecht, 1988) was highly polyphyletic; the tribes Cephalantheae, Chiococceae, and Vanguerieae were not close to each other or to Guettardeae (*Antirhea* Comm. ex Juss., *Guettarda* L.). The subfamily Cinchonoideae was not supported as a monophyletic group in Bremer and Jansen (1991). New relationships included *Chiococca* P. Browne and *Erithalis* P. Browne of the Chiococceae as close to *Coutarea* Aubl. and *Exostema* (Pers.) Bonpl. of the former Cinchonoideae. It was also shown that Cephalantheae and Vanguerieae are closest to Naucleae and Ixoroideae, respectively.

During the First International Conference on Rubiaceae at the Missouri Botanical Garden in 1993, an analysis of *rbcL* sequences from 49 Rubiaceae genera representing 23 tribes was presented (later published in Bremer et al., 1995). That study included outgroups from Gentianales and also Oleaceae. Rubiaceae came out as sister group to the rest of Gentianales in agreement with an *rbcL* study of the Asteridae (Olmstead et al., 1993) and a morphological analysis of Loganiaceae and Gentianales (Bremer & Struwe, 1992). In the 1995 study, the family was classified into three subfamilies: Rubioideae (including Rubieae, Anthospermeae, Hedyotideae, Morindeae, Ophiorrhizeae, Psychotrieae, and Theligoneae), Ixoreae s.l. (including Coffeae, Gardenieae, Pavetteae, and Vanguerieae, as well as several genera of the

former Cinchonoideae), and Cinchonoideae s. str. (including Cinchoneae, Chiococceae s.l., Guettardeae, Hamelieae, Hillieae, Naucleaeae, and Rondeletieae). The genus *Luculia* Sweet was unresolved at the base of the family, and the genus *Hintonia* Bullock was unresolved between Cinchonoideae and Ixoroideae. At about the same time, Ehrendorfer et al. (1994) published the first analysis of the *atpB-rbcL* spacer of cpDNA in a short communication, foregoing a more comprehensive study of the Rubieae (Natali et al., 1995; see below) that was presented at the 1993 meeting in St. Louis. They showed results for eight genera (*Bouvardia* Salisb., *Coffea*, *Galium* L., *Hydnophytum* Jack, *Ixora* L., *Pentas* Benth., *Psychotria* L., and *Rubia* L.) representing five tribes, and the resulting tree was concluded to be in agreement with the relationships based on the restriction site data, with *Ixora* and *Coffea* together as sister group to the rest.

In a study investigating effects of the number of characters, the number of taxa, and the kind of data for bootstrap values within a phylogenetic tree, Bremer et al. (1999) used different data sets of Rubiaceae. In the study, 43 Rubiaceae genera together with 11 outgroups representing the rest of the Gentianales were analyzed for *rbcL* and *ndhF*. It was shown that the percentage of supported nodes within the trees positively correlated to the number of characters, but negatively correlated to the number of taxa. Further, the three subfamilies Rubioideae, Cinchonoideae, and Ixoroideae were all monophyletic and highly supported (100% bootstrap). There were only two investigated genera, *Luculia* and *Coptosapelta* Korth., placed at the base of the Rubiaceae, that were left unclassified to subfamily.

Rova et al. (2002) performed a phylogenetic analysis of *trnL-F* for a large data set including 154 Rubiaceae sequences and 11 outgroups in a study to test what had been suggested to form a tight complex of the tribes Condamineae, Rondeletieae, and Sipaneeae by Robbrecht (1988). Several earlier molecular studies had indicated that this suggested relationship had no support (e.g., Bremer et al., 1995; Andersson & Rova, 1999). Rova et al. (2002) included taxa from most parts of the family, and the results were very much in agreement with earlier molecular analyses. Their main conclusions were that most former Condamineae and several Rondeletieae genera (*Aleisanthia* Ridl., *Aleisanthiopsis* Tange, *Augusta* Pohl, *Greenea* Wight & Arn., and *Wendlandia* DC.) are members of the Ixoroideae, as are the Sipaneeae (*Maguireothamnus* Steyerem., *Neobertiera* Wernham, and *Sipanea* Aubl.) and its sister clade (*Gleasonia* Standl., *Molopanthera* Turcz., and *Posoqueria* Aubl., the latter two correspond to the circumscription of tribe Posoquerieae by Delprete et

al. [2004]). Condamineae (as the first Ixoroideae clade [*Condaminea* DC., *Alseis* Schott, *Bathysa* C. Presl, *Calycophyllum*, *Capirona* Spruce, *Chimarrhis* Jacq., *Dioicodendron* Steyerem., *Dolichodelphys* K. Schum. & K. Krause, *Elaeagia* Wedd., *Emmenopterys* Oliv., *Hippotis* Ruiz & Pav., *Macbrideina* Standl., *Parachimarrhis* Ducke, *Pentagonia* Benth., *Picardaea* Urb., *Pinckneya*, *Pogonopus*, *Rustia* Klotzsch, *Sommera* Schldl., *Warszewiczia* Klotzsch, and *Wittmackanthus* Kuntze]) formed a supported but almost unresolved clade of Ixoroideae. Rova et al. (2002) found no support for a broad circumscription of the tribe Rondeletieae, and Guettardeae (sensu Robbrecht, 1988, 1993), including several former Rondeletieae taxa, was paraphyletic. Rondeletieae s. str. was almost entirely Antillean in geographic distribution. Furthermore, there was support for separation of several genera from the genus *Rondeletia* L. (*Arachnothryx* Planch., *Rogiera* Planch., *Roigella* Borhidi & M. Fernández Zeq., and *Suberanthus* Borhidi & M. Fernández Zeq.). The *trnL-F* data corroborated the position of *Retiniphyllum* Humb. & Bonpl. (Retinophylleae) in the Ixoroideae (in Antirheoideae fide Robbrecht, 1988) between Mussaendeae and the main part of Ixoroideae as proposed in Andersson and Rova (1999), based on *rps16* data. Rova et al. (2002) also presented new taxonomic positions for several genera sequenced for the first time: *Allenanthus* Standl. (close to Guettardeae/Rondeletieae), *Blepharidium* Standl. (Rondeletieae), *Chione* DC. (close to Hamelieae–Hillieae), *Coutaportla* Urb. (Chiococceae), *Dolichodelphys* (close to *Calycophyllum*–*Condaminea*–*Hippotis*), *Mazaea* Krug & Urb. (Rondeletieae), *Neobertiera* (Sipaneeae), *Neoblakea* Standl. (close to Guettardeae–Rondeletieae), *Phialanthus* Griseb. (Chiococceae–Catesbaeeae), *Phyllacanthus* Hook. f. (Chiococceae–Catesbaeeae), *Phyllomelia* Griseb. (Rondeletieae), *Schmidtottia* Urb. (Chiococceae–Catesbaeeae), and *Suberanthus* (Rondeletieae).

The studies discussed above provide strong support for three large supported subclades corresponding to the subfamilies Rubioideae, Ixoroideae, and Cinchonoideae. However, the basalmost nodes in the family are still uncertain or unresolved (but these basal nodes are under investigation by Rydin et al. [2009]). We still do not know how the genus *Luculia* and the tribe Coptosapelteae are related to the three subfamilies, for example. To have a detailed phylogenetic picture of the family and to understand circumscriptions of subgroups, we need sequence data for all described genera, and, so far, more than 200 genera have not been included in published molecular analyses. In most cases, morphological data or traditional classification can indicate a possible phylogenetic position, such as placing genera within tribes, but for some genera this is difficult. Further-

Table 1. List of the 348 Rubiaceae genera discussed in the text, with tribal position.

Genus	Position	Genus	Position
<i>Acranthera</i> Arn. ex Meisn.	no tribe	<i>Ceratopyxis</i> Hook. f.	CHI
<i>Adina</i> Salisb.	NAU	<i>Ceriscoides</i> (Hook. f.) Tirveng.	GAR*
<i>Adinauclea</i> Ridsdale	NAU	<i>Chalepophyllum</i> Hook. f.	SIP
<i>Afrocanthium</i> (Bridson) Lantz & B. Bremer	VAN	<i>Chassalia</i> Poir.	PSY
<i>Aidia</i> Lour.	GAR*	<i>Chazaliella</i> E. M. A. Petit & Verdc.	PSY
<i>Alberta</i> E. Mey.	ALB	<i>Chimarrhis</i> Jacq.	CON
<i>Aleisanthia</i> Ridl.	IXOR, no tribe	<i>Chiococca</i> P. Browne	CHI
<i>Aleisanthiopsis</i> Tange	IXOR, no tribe	<i>Chione</i> DC.	c HAM/HIL
<i>Alibertia</i> A. Rich. ex DC.	GAR*	<i>Ciliosemina</i> Antonelli	CIN
<i>Allenanthus</i> Standl.	c GUE/RON	<i>Cinchona</i> L.	CIN
<i>Alseis</i> Schott	CON	<i>Cinchonopsis</i> L. Andersson	CIN
<i>Amaioua</i> Aubl.	GAR*	<i>Coccocypselum</i> P. Browne	COU
<i>Amphiasma</i> Bremek.	SPE	<i>Coddia</i> Verdc.	GAR*
<i>Amphidasya</i> Standl.	URO	<i>Coelospermum</i> Blume	MOR*
<i>Ancylanthos</i> Desf.	VAN	<i>Coffea</i> L.	COF
<i>Anthorrhiza</i> C. R. Huxley & Jebb	PSY	<i>Commitheca</i> Bremek.	URO
<i>Anthospermum</i> L.	ANT	<i>Condaminea</i> DC.	CON
<i>Antirhea</i> Comm. ex Juss.	GUE	<i>Conostomium</i> (Stapf.) Cufod.	SPE
<i>Aoranthe</i> Somers	GAR*	<i>Coprosma</i> J. R. Forst. & G. Forst.	ANT
<i>Aphaenandra</i> Miq.	MUS	<i>Coptosapelta</i> Korth.	COP
<i>Arachnothryx</i> Planch.	RON	<i>Corynanthe</i> Welw.	NAU
<i>Arcytophyllum</i> Willd. ex Schult. & Schult. f.	SPE	<i>Cosmibuena</i> Ruiz & Pav.	HIL
<i>Argostemma</i> Wall.	ARG	<i>Coussarea</i> Aubl.	COU
<i>Asemnantha</i> Hook. f.	CHI	<i>Coutaportla</i> Urb.	CHI
<i>Asperula</i> L.	RUB	<i>Coutarea</i> Aubl.	CHI
<i>Atractocarpus</i> Schltr. & K. Krause	GAR*	<i>Craterispermum</i> Benth.	CRA
<i>Atractogyne</i> Pierre	GAR*	<i>Cremaspora</i> Benth.	CRE
<i>Augusta</i> Pohl	IXOR, no tribe	<i>Crucianella</i> L.	RUB
<i>Badusa</i> A. Gray	CHI	<i>Cruciata</i> Mill.	RUB
<i>Bathysa</i> C. Presl	CON	<i>Crusea</i> Cham. & Schltld.	SPE
<i>Benkara</i> Adans.	GAR*	<i>Cubanola</i> Aiello	CHI
<i>Bertiera</i> Aubl.	BER	<i>Cyclophyllum</i> Hook. f.	VAN
<i>Bikkia</i> Reinw.	CHI	<i>Damnacanthus</i> C. F. Gaertn.	MOR*
<i>Blepharidium</i> Standl.	RON	<i>Danais</i> Comm. ex Vent.	DAN
<i>Borojoa</i> Cuatrec.	GAR*	<i>Deccania</i> Tirveng.	GAR*
<i>Borreria</i> G. Mey.	SPE	<i>Declieuxia</i> Kunth	COU
<i>Bouvardia</i> Salisb.	SPE	<i>Dendrosipanea</i> Ducke	SIP
<i>Bremeria</i> Razafim. & Alejandro	MUS	<i>Dentella</i> J. R. Forst. & G. Forst.	SPE
<i>Breonadia</i> Ridsdale	NAU	<i>Dialypetalanthus</i> Kuhlman.	IXOR, no tribe
<i>Breonia</i> A. Rich. ex DC.	NAU	<i>Dictyandra</i> Welw. ex Hook. f.	PAV
<i>Burchellia</i> R. Br.	GAR*	<i>Didymaea</i> Hook. f.	RUB
<i>Burttidavya</i> Hoyle	NAU	<i>Didymosalpinx</i> Keay	GAR*
<i>Calochone</i> Keay	GAR*	<i>Diodia</i> L.	SPE
<i>Calycophyllum</i> DC.	CON	<i>Dioicodendron</i> Steyerm.	CON
<i>Canthium</i> Lam.	VAN	<i>Diplospora</i> DC.	COF
<i>Capirona</i> Spruce	CON	<i>Dolichodelphys</i> K. Schum. & K. Krause	CON
<i>Carapichea</i> Aubl.	PSY	<i>Duperrea</i> Pierre ex Pit.	GAR*
<i>Carpacoce</i> Sond.	ANT	<i>Duroia</i> L. f.	GAR*
<i>Carphalea</i> Juss.	KNO	<i>Durringtonia</i> R. J. F. Hend. & Guymer	ANT
<i>Carterella</i> Terrell	SPE	<i>Ecpoma</i> K. Schum.	SAB-tent
<i>Casasia</i> A. Rich.	GAR*	<i>Elaeagia</i> Wedd.	CON
<i>Catesbaea</i> L.	CHI	<i>Emmenopterys</i> Oliv.	CON
<i>Catunaregam</i> Wolf	GAR*	<i>Erithalis</i> P. Browne	CHI
<i>Cephalanthus</i> L.	NAU	<i>Ernodea</i> Sw.	SPE
		<i>Euclinia</i> Salisb.	GAR*
		<i>Exostema</i> (Pers.) Bonpl.	CHI

Table 1. Continued.

Genus	Position	Genus	Position
<i>Fadogia</i> Schweinf.	VAN	<i>Leroya</i> Cavaco	VAN
<i>Faramea</i> Aubl.	COU	<i>Limnosipanea</i> Hook. f.	SIP
<i>Feretia</i> Delile	OCT	<i>Luculia</i> Sweet	no tribe
<i>Fernelia</i> Comm. ex Lam.	OCT	<i>Ludekia</i> Ridsdale	NAU
<i>Gaertnera</i> Lam.	GAE	<i>Macbrideina</i> Standl.	CON
<i>Galium</i> L.	RUB	<i>Macrosphyra</i> Hook. f.	GAR*
<i>Galopina</i> Thunb.	ANT	<i>Maguireothamnus</i> Steyerm.	SIP
<i>Gardenia</i> Ellis	GAR*	<i>Manostachya</i> Bremek.	SPE
<i>Genipa</i> L.	GAR*	<i>Margaritopsis</i> C. Wright	PSY
<i>Geophila</i> D. Don	PSY	<i>Maschalocorymbus</i> Bremek.	URO
<i>Gleasonia</i> Standl.	c POS	<i>Massularia</i> (K. Schum.) Hoyle	GAR*
<i>Glossostipula</i> Lorence	GAR*	<i>Mazaea</i> Krug & Urb.	RON
<i>Gomphocalyx</i> Baker	SPE	<i>Melanopsidium</i> Colla	GAR*
<i>Greenea</i> Wight & Arn.	IXOR, no tribe	<i>Metadina</i> Bakh. f.	NAU
<i>Guettarda</i> L.	GUE	<i>Meyna</i> Roxb. ex Link	VAN
<i>Gynochthodes</i> Blume	MOR*	<i>Mitchella</i> L.	MOR*
<i>Gyrostipula</i> J.-F. Leroy	NAU	<i>Mitracarpus</i> Zucc. ex Schult. & Schult. f.	SPE
<i>Haldina</i> Ridsdale	NAU	<i>Mitragyna</i> Korth.	NAU
<i>Hamelia</i> Jacq.	HAM	<i>Mitriostigma</i> Hochst.	GAR*
<i>Hedyotis</i> L.	SPE	<i>Molopanthera</i> Turcz.	POS
<i>Heinsia</i> DC.	MUS	<i>Morelia</i> A. Rich. ex DC.	GAR*
<i>Heinsenia</i> K. Schum.	GAR*	<i>Morierina</i> Vieill.	CHI
<i>Hekistocarpa</i> Hook. f.	SAB	<i>Morinda</i> L.	MOR*
<i>Heterophyllaea</i> Hook. f.	COU	<i>Multidentia</i> Gilli	VAN
<i>Hindsia</i> Benth. ex Lindl.	COU	<i>Mussaenda</i> L.	MUS
<i>Hintonia</i> Bullock	CHI	<i>Mussaendopsis</i> Baill.	CON
<i>Hippotis</i> Ruiz & Pav.	CON	<i>Mycetia</i> Reinw.	ARG
<i>Hoffmannia</i> Sw.	HAM	<i>Myonima</i> Comm. ex Juss.	IXO
<i>Houstonia</i> L.	SPE	<i>Myrmecodia</i> Jack	PSY
<i>Hutchinsonia</i> Robyns	VAN	<i>Myrmeconuclea</i> Merr.	NAU
<i>Hydnophytum</i> Jack	PSY	<i>Myrmephytum</i> Becc.	PSY
<i>Hydrophylax</i> L. f.	SPE	<i>Nauclea</i> L.	NAU
<i>Hymenocoleus</i> Robbr.	PSY	<i>Neblinathamnus</i> Steyerm.	SIP-tent
<i>Hymenodictyon</i> Wall.	HYM	<i>Nenax</i> Gaertn.	ANT
<i>Hyperacanthus</i> E. Mey. ex Bridson	GAR*	<i>Neobertiera</i> Wernham	SIP
<i>Ibetrulia</i> Bremek.	GAR*	<i>Neoblakea</i> Standl.	c GUE/RON
<i>Isertia</i> Schreb.	ISE	<i>Neolamarchia</i> Bosser	NAU
<i>Isidorea</i> A. Rich. ex DC.	CHI	<i>Neolaugeria</i> Nicolson	GUE
<i>Ixora</i> L.	IXO	<i>Neoleroya</i> Cavaco	VAN
<i>Janotia</i> J.-F. Leroy	NAU	<i>Neomussaenda</i> Tange	MUS-tent
<i>Joosia</i> H. Karst	CIN	<i>Neonauclea</i> Merr.	NAU
<i>Kailarsenia</i> Tirveng.	GAR*	<i>Nertera</i> Banks & Sol. ex Gaertn.	ANT
<i>Keetia</i> E. Phillips	VAN	<i>Neurocalyx</i> Hook.	OPH
<i>Kelloggia</i> Torr. ex Benth. & Hook. f.	c RUB	<i>Normandia</i> Hook. f.	ANT
<i>Kerianthera</i> J. H. Kirkbr.	ISE	<i>Notopleura</i> (Benth. & Hook. f.) Bremek.	PSY
<i>Knoxia</i> L.	KNO	<i>Ochreinauclea</i> Ridsdale & Bakh. f.	NAU
<i>Kraussia</i> Harv.	OCT	<i>Oldenlandia</i> L.	SPE
<i>Kutchubaea</i> Fisch. ex DC.	GAR*	<i>Oldenlandiopsis</i> Terrell & W. H. Lewis	SPE
<i>Ladenbergia</i> Klotzsch	CIN	<i>Oligocodon</i> Keay	GAR*
<i>Lagynias</i> E. Mey. ex Robyns	VAN	<i>Opercularia</i> Gaertn.	ANT
<i>Landiopsis</i> Bosser	MUS	<i>Ophiorrhiza</i> L.	OPH
<i>Lasianthus</i> Jack	LAS	<i>Oreopolus</i> Schldtl.	COU
<i>Leptactina</i> Hook. f.	PAV	<i>Osa</i> Aiello	CHI
<i>Leptodermis</i> Wall.	PAE	<i>Otiophora</i> Zucc.	KNO
<i>Leptostigma</i> Arn.	ANT	<i>Otomeria</i> Benth.	KNO
<i>Lerchea</i> L.	OPH	<i>Oxyanthus</i> DC.	GAR*

Table 1. Continued.

Genus	Position	Genus	Position
<i>Oxyceros</i> Lour.	GAR*	<i>Retiniphyllum</i> Humb. & Bonpl.	RET
<i>Pachystigma</i> Hochst.	VAN	<i>Richardia</i> L.	SPE
<i>Paederia</i> L.	PAE	<i>Rogiera</i> Planch.	RON
<i>Pagamea</i> Aubl.	GAE	<i>Roigella</i> Borhidi & M. Fernández Zeq.	RON
<i>Palicourea</i> Aubl.	PSY	<i>Rondeletia</i> L.	RON
<i>Parachimarrhis</i> Ducke	CON	<i>Rosenbergiodendron</i> Fagerl.	GAR*
<i>Paracoffea</i> J.-F. Leroy	COF	<i>Rothmannia</i> Thunb.	GAR*
<i>Paracorynanthe</i> Capuron	HYM	<i>Rubia</i> L.	RUB
<i>Paragenipa</i> Baill.	OCT	<i>Rudgea</i> Salisb.	PSY
<i>Parapentas</i> Bremek.	KNO	<i>Rustia</i> Klotzsch	CON
<i>Pauridiantha</i> Hook. f.	URO	<i>Rutidea</i> DC.	PAV
<i>Pausinystalia</i> Pierre ex Beille	NAU	<i>Rytigynia</i> Blume	VAN
<i>Pavetta</i> L.	PAV	<i>Sabicea</i> Aubl.	SAB
<i>Pentagonia</i> Benth.	CON	<i>Salzmannia</i> DC.	CHI
<i>Pentaloncha</i> Hook. f.	SAB-tent	<i>Sarcocephalus</i> Azfel. ex R. Br.	NAU
<i>Pentanisia</i> Harv.	KNO	<i>Schizomussaenda</i> H. L. Li	MUS
<i>Pentanopsis</i> Rendle	SPE	<i>Schizostigma</i> Arn. ex Meisn.	SAB-tent
<i>Pentas</i> Benth.	KNO	<i>Schmidtottia</i> Urb.	CHI
<i>Peponidium</i> (Baill.) Arènes	VAN	<i>Schradera</i> Vahl	SCH
<i>Pertusadina</i> Ridsdale	NAU	<i>Schumanniphyton</i> Harms	GAR*
<i>Phialanthus</i> Griseb.	CHI	<i>Scolosanthus</i> Vahl	CHI
<i>Phuopsis</i> (Griseb.) Hook. f.	RUB	<i>Scyphiphora</i> C. F. Gaertn.	c IXO/VAN
<i>Phyllacanthus</i> Hook. f.	CHI	<i>Scyphochlamys</i> Balf. f.	VAN
<i>Phyllis</i> L.	ANT	<i>Serissa</i> Comm. ex A. Juss.	PAE
<i>Phyllomelia</i> Griseb.	RON	<i>Sherardia</i> L.	RUB
<i>Phylohydrax</i> Puff	SPE	<i>Sherbournia</i> G. Don	GAR*
<i>Picardaea</i> Urb.	CON	<i>Siemensia</i> Urb.	CHI
<i>Pimentelia</i> Wedd.	CIN-tent	<i>Sinoadina</i> Ridsdale	NAU
<i>Pinckneya</i> Michx.	CON	<i>Sipanea</i> Aubl.	SIP
<i>Pittierothamnus</i> Steyerl.	SAB-tent	<i>Sipaneopsis</i> Steyerl.	SIP
<i>Placopoda</i> Balf. f.	KNO	<i>Solenandra</i> Hook. f.	CHI
<i>Platycarpum</i> Humb. & Bonpl.	SIP	<i>Sommeria</i> Schldl.	CON
<i>Pogonopus</i> Klotzsch	CON	<i>Spermacoce</i> L.	SPE
<i>Pomax</i> DC.	ANT	<i>Spermadictyon</i> Roxb.	PAE
<i>Porterandia</i> Ridl.	GAR*	<i>Sphinctanthus</i> Benth.	GAR*
<i>Portlandia</i> P. Browne	CHI	<i>Squamellaria</i> Becc.	PSY
<i>Posoqueria</i> Aubl.	POS	<i>Stachyarrhena</i> Hook. f.	GAR*
<i>Pouchetia</i> DC.	OCT	<i>Stenaria</i> (Raf.) Terrell	SPE
<i>Praravinia</i> Korth.	URO	<i>Stenostomum</i> C. F. Gaertn.	GUE
<i>Pravinaria</i> Bremek.	URO	<i>Steyermarkia</i> Standl.	SIP-tent
<i>Preussiodora</i> Keay	GAR*	<i>Stilpnophyllum</i> Hook. f.	CIN
<i>Pseudocinchona</i> A. Chev. ex Perrot	NAU	<i>Stipularia</i> P. Beauv.	SAB-tent
<i>Pseudomussaenda</i> Wernham	MUS	<i>Streblosa</i> Korth.	PSY
<i>Pseudopeponidium</i> Arènes	VAN	<i>Strumpfia</i> Jacq.	c CHI
<i>Pseudosabicea</i> N. Hallé	SAB	<i>Suberanthus</i> Borhidi & M. Fernández Zeq.	RON
<i>Psilanthus</i> Hook. f.	COF	<i>Sukunia</i> A. C. Sm.	GAR*
<i>Psychotria</i> L.	PSY	<i>Tamilnadia</i> Tirveng. & Sastre	GAR*
<i>Psydrax</i> Gaertn.	VAN	<i>Tamridaea</i> Thulin & B. Bremer	SAB
<i>Psyllocarpus</i> Mart. & Zucc.	SPE	<i>Tapiphyllum</i> Robyns	VAN
<i>Pteridocalyx</i> Wernham	SIP-tent	<i>Tarenna</i> Gaertn.	PAV
<i>Putoria</i> Pers.	PUT	<i>Tarennoidea</i> Tirveng. & Sastre	GAR*
<i>Pyrostria</i> Comm. ex Juss.	VAN	<i>Temnopteryx</i> Hook. f.	SAB-tent
<i>Ramosmania</i> Tirveng. & Verdc.	OCT	<i>Theligonum</i> L.	THE
<i>Randia</i> L.	GAR*	<i>Timonius</i> DC.	GUE
<i>Raritebe</i> Wernham	URO	<i>Tocoyena</i> Aubl.	GAR*
<i>Readea</i> Gillespie	PSY	<i>Tricalysia</i> A. Rich. ex DC.	COF
<i>Remijia</i> DC.	CIN	<i>Trichostachys</i> Hook. f.	LAS

Table 1. Continued.

Genus	Position	Genus	Position
<i>Trukia</i> Kaneh.	GAR*	<i>Wendlandia</i> DC.	IXOR, no tribe
<i>Uncaria</i> Schreb.	NAU	<i>Versteegia</i> Valetton	IXO
<i>Urophyllum</i> Wall.	URO	<i>Virectaria</i> Bremek.	SAB
<i>Valantia</i> L.	RUB	<i>Wittmackanthus</i> Kuntze	CON
<i>Vangueria</i> Juss.	VAN	<i>Xanthophytum</i> Reinw. ex Blume	OPH
<i>Warszewiczia</i> Klotzsch	CON	<i>Yutajea</i> Steyererm.	ISE

* Paraphyletic/polyphyletic tribes.

Abbreviations: no tribe, without tribal position (taxon has been molecularly investigated, but has not been placed within any described tribe); c, close to (taxon is sister group to or close to one or two tribes); tent, tentatively (taxon is not molecularly investigated but has been suggested to be included in the tribe); ALB, Albertainae; ANT, Anthospermeae; ARG, Argostemmateae; BER, Bertiereae; CHI, Chiococceae; CIN, Cinchoneae; COF, Coffeae; CON, Condamineae; COP, Coptosapelteae; COU, Coussareae; CRA, Craterispermeae; CRE, Cremasporae; DAN, Danaideae; GAE, Gaertnereae; GAR*, Gardenieae; GUE, Guettardeae; HAM, Hamelieae; HIL, Hillieae; HYM, Hymenodictyeae; ISE, Isertieae; IXO, Ixoreae; IXOR, Ixoroideae; KNO, Knoxieae; LAS, Lasiantheae; MOR*, Morindeae; MUS, Mussaendeae; NAU, Naucleaeae; OCT, Octotropideae; OPH, Ophiorrhizeae; PAE, Paederieae; PAV, Pavetteae; POS, Posoquerieae; PSY, Psychotrieae; PUT, Putorieae; RET, Retiniphyllae; RON, Rondeletieae; RUB, Rubieae; SAB, Sabiceae; SCH, Schradereae; SIP, Sipaneeae; SPE, Spermaceae; THE, Theligoneae; URO, Urophyllae; VAN, Vanguerieae.

more, if Rubiaceae should become the perfect model family for ecological, evolutionary, biogeographic, or other studies, we must work hard over the coming years with the challenge to sequence all described genera and species.

SUBFAMILY RUBIOIDEAE

At the Second International Conference on Rubiaceae in Brussels in 1995, Bremer (1996) focused on subfamily Rubioideae; 59 taxa representing most tribes of the subfamily were investigated for *rbcL*. The analysis showed that Anthospermeae, Rubieae, Spermaceae s.l. (including the *Pentas* group – Knoxieae [*Pentas*, *Carphalea* Juss., *Parapentas* Bremek., *Pentanisia* Harv., and *Placopoda* Balf. f.], Hedyotideae, and Spermaceae s. str.), and Psychotrieae s.l. (including also Morindeae and Gaertnereae) are monophyletic. Paederieae and Argostemmateae were shown to be polyphyletic. *Lasianthus* Jack and *Gaertnera* Lam. were shown not to belong to Psychotrieae s. str. The following genera from different tribes were represented by single species and thus could not be tested for monophyly, but could be positioned phylogenetically: *Coccocypselum* P. Browne (Coussareae), *Danais* Comm. ex Vent., *Faramea* Aubl. (Coussareae), *Mycetia* Reinw., *Ophiorrhiza* L., *Pauridiantha* Hook. f. (Urophyllae), and *Theligonum* L. The genus *Mycetia* was shown to be close to *Argostemma* Wall. and not a member of the Isertieae (Robbrecht, 1988).

A few years later, Andersson and Rova (1999) published an analysis of *rps16* sequences from 143 Rubiaceae taxa and five outgroups, also focusing on subfamily Rubioideae. The results confirmed those

based on *rbcL* data (Bremer, 1996) for the main groups of the family, but more taxa were included and the support was stronger for several clades. A few differences between the *rps16* and the *rbcL* results were revealed. In the *rbcL* data, Spermaceae s.l. forms one monophyletic clade with 76% jackknife support including three of the tribes recognized by Andersson and Rova (1999), Spermaceae, Heyotideae, and Knoxieae. In the *rps16* analysis, Knoxieae is instead sister to a larger group of Spermaceae, Heyotideae, and also Paederieae and Rubieae, but without support. Morindeae (80% bootstrap support) is found to be monophyletic, which disagrees with the *rbcL* data. The included and supported tribes of the Rubioideae from the base of the tree were the following: Urophyllae (*Urophyllum* Wall., *Pauridiantha*, *Raritebe* Wernham [100%]), Ophiorrhizeae (single taxon), Coussareae (*Coussarea* Aubl., *Faramea* [76%]), Coccocypseae (100%) together with the two unclassified genera *Hindsia* Benth. ex Lindl. and *Declieuxia* Kunth, Cruckshanksieae (*Heterophyllaea* Hook. f., *Oreopolus* Schltdl. [78%]), Gaertnereae (*Gaertnera*, *Pagamea* Aubl. [100%]), Schradereae (*Schradera* Vahl, single taxon), Morindeae (*Morinda* L., *Damnacanthus* C. F. Gaertn., *Mitchella* L., *Coelospermum* Blume, *Gynochthodes* Blume [80%]), Psychotrieae (*Psychotria*, *Chassalia* Poir., *Chazaliella* E. M. A. Petit & Verdc., *Geophila* D. Don, *Hydnophytum*, *Margaritopsis* C. Wright, *Myrmecodia* Jack, *Palicourea* Aubl., *Readea* Gillespie, *Rudgea* Salisb., *Squamellaria* Becc., *Streblosa* Korth. [99%]), Knoxieae (*Knoxia* L., *Otiophora* Zucc., *Otomeria* Benth., *Pentas*, *Pentanisia* Harv. [100%]), Anthospermeae (*Coprosma* J. R. Forst. & G. Forst., *Galopina* Thunb., *Leptostigma* Arn., *Nenax* Gaertn., *Nertera*

Banks & Sol. ex Gaertn., *Opercularia* Gaertn., *Phyllis* L. [53%]), Rubieae (*Rubia*, *Asperula* L., *Crucianella* L., *Galium*, *Sherardia* L., *Valantia* L. [100%]), and Spermaceae (*Spermacoce* L., *Borreria* G. Mey., *Crusea* Cham. & Schltld., *Diodia* L., *Ernodea* Sw., *Mitracarpus* Zucc. ex Schult. & Schult. f., *Psyllocarpus* Mart. & Zucc., *Richardia* L. [85%]). The tribes Paederieae and Hedyotideae were paraphyletic as in Bremer (1996). The genus *Psychotria* is paraphyletic in agreement with Nepokroeff et al. (1999).

A new phylogeny and a new comprehensive classification of Rubioideae were presented by Bremer and Manen (2000). They analyzed 151 genera with three different molecular markers, *rbcL*, *atpB-rbcL*, and *rps16* (latter data from Andersson & Rova, 1999). The separate markers and combined analyses gave similar results. The tribes Ophiorrhizeae (*Ophiorrhiza*, *Neurocalyx*, *Lerchea* L., *Xanthophytum*), Urophyllaeae (*Urophyllum*, *Amphidasya* Standl., *Commitheca* Bremek., *Maschalocorymbus* Bremek., *Praravinia* Korth., *Pravinaria* Bremek., *Pauridiantha*), Lasiantheae (*Lasianthus*, *Trichostachys* Hook. f.), and Coussareeae formed a grade to the rest of the family, which consisted of two newly established but informal groups (with 99% and 100% bootstrap support, respectively): the Psychotrieae alliance (Psychotrieae, Craterispermeae [*Craterispermum* Benth.], Gaertneriae, Morindeae [paraphyletic], Schradereae) and the Spermaceae alliance (Spermaceae, Anthospermeae, Argostemmateae, Danaideae, Paederieae [paraphyletic], Rubieae, Theligoneae). Of the accepted 16 Rubioideae tribes, 11 were in agreement with earlier circumscriptions. Ophiorrhizeae, Coussarieae, and Spermaceae received wider circumscriptions, and Lasiantheae and Danaideae were described as new. All monophyletic tribes received 100% bootstrap support (except for Psychotrieae, with only 81% support).

From the studies outlined above, there is support for most of the Rubioideae tribes and the many relationships between them. However, at the end of 2005, only seven of the tribes had been the subject of detailed studies, presented below. It should be stressed that several tribes and also relationships between tribes (e.g., the basal clades Coussareae, Lasiantheae, Ophiorrhizeae, Urophyllaeae, and clades within the Psychotrieae alliance) are under investigation. Rubioideae is probably the best understood subfamily phylogenetically, but still only a minority of its species have been investigated. The most important task for the coming years will be to analyze and sequence most species of the large and problematic genera. Rubioideae contains 11 of the 20 largest genera of the family (*Psychotria*, *Galium*, *Ophiorrhiza*, *Palicourea*, *Spermaceae*, *Oldenlandia* L., *La-*

sianthus, *Faramea*, *Asperula*, *Argostemma*, and *Coussarea*). These genera together contain about 40% of all species in the family and, because some of these genera represent much of the Rubiaceae species diversity, understanding of their phylogeny would be an important asset for deeper evolutionary studies.

Tribe Rubieae was investigated by Manen et al. (1994), who used the *atpB-rbcL* spacer of 25 species of the tribe. They found support for a monophyletic Rubieae, and the two investigated species of *Rubia* were found to be sister to the rest of the tribe. Manen and coworkers identified four further clades, but with low or moderate bootstrap support. The highest support (87% bootstrap support) was for the *Sherardia* clade (*Sherardia* together with *Crucianella*, and *Phuopsis* (Griseb.) Hook. f.) and 81% bootstrap support was found for the *Asperula* clade (*Asperula* together with *Galium elongatum* C. Presl and *G. palustre* L.). The relationship between the four clades was unresolved and *Galium* was paraphyletic. Later, Natali et al. (1995) added more sequences to the Manen et al. (1994) data set, for a total of 70 Rubieae species and 25 taxa of 12 other tribes of Rubioideae. They got 100% bootstrap support for tribe Rubieae and subfamily Rubioideae. They excluded Ophiorrhizeae, and, with that circumscription, the subfamily was also characterized by a 204 bp deletion in the *atpB-rbcL* region. Natali et al. (1995) divided the Rubieae into the same five clades as in Manen et al. (1994), but with lower support; *Rubia* is still monophyletic (100% support) and sister to the rest. They showed that the genus *Asperula* is paraphyletic, with all added species instead belonging to their *Sherardia* clade. Manen and Natali (1996), in an article about the deletion in the *atpB-rbcL* region (loss of an *atpB* promoter) in the Rubioideae, investigated the *atpB-rbcL* spacer from representatives of the whole family, but with a main focus on subfamily Rubioideae. They presented a tree for 22 genera (they refer to an analysis of 111 taxa, which was not presented in the article). They rooted the published tree between subfamily Ixoroideae (*Coffea* and *Ixora*) and the rest. The Cinchonoideae, including five genera, was sister to a clade including their Rubioideae and *Ophiorrhiza*. They found strong support for Rubioideae (*Ophiorrhiza* excluded) and Rubieae (including the two genera *Rubia* and *Didymaea* Hook. f.). Rubieae was sister to Theligoneae and *Putoria* Pers. and these are sister to *Paederia* L.; other Rubioideae taxa in the analysis included Anthospermeae, Coccosypseae, Hedyotideae, Morindeae, Psychotrieae, and Spermaceae. Their results agree with the *rbcL* data (Bremer & Jansen, 1991; Bremer et al., 1995) that Hamelieae does not belong to Rubioideae but instead to the Cinchonoideae. Their main conclusion is that the lack

of the *atpB* promoter for the Rubioideae excluding the Ophiorrhizaceae “gives strong evidences on the boundary between the subfamily Rubiodieae and the other Rubiaceae” (Manen & Natali, 1996: 56). However, they do not suggest any taxonomic position, or to which subfamily Ophiorrhizaceae belongs. In another article, Natali et al. (1996) published the same tree based on *atpB-rbcL* data for the 22 genera, but they also analyzed the Rubieae with a denser sampling of 78 Rubieae taxa. The result agrees with their earlier analysis in Natali et al. (1995) but divides the Rubieae into seven clades, now with *Didymaea* as sister to the rest, followed by the clades *Rubia*, *Asperula* sect. *Asperula*, *Asperula* sect. *Glabella*, *Sherardia*, *Cruciata* Mill., and *Galium* sect. *Galium*. Only *Rubia* was highly supported as monophyletic. Despite the extended sampling, the relationships between the different groups were unresolved.

Kelloggia Torr. ex Benth. & Hook. f. (Paederieae fide Robbrecht [1988], but in Backlund et al. [2007] without tribal position), a genus of two species with disjunct distribution in western North America and the western part of eastern Asia, was analyzed with three chloroplast markers (*rbcL*, *atpB-rbcL*, *rps16*) by Nie et al. (2005). They showed that the genus is monophyletic and sister to the Rubieae. *Kelloggia* was also included in a Ph.D. thesis by Backlund (2005), and the same position of the genus close to Rubieae was well supported. It was further demonstrated (Backlund, 2005) that the clade of Theligoneae–*Kelloggia*–Rubieae is sister group to a reestablished tribe Putorieae (a position that makes the rest of the Paederieae monophyletic).

The taxonomically complex tribe Psychotrieae and the very large genus *Psychotria* were molecularly investigated for the first time by Nepokroeff et al. (1999). They analyzed 85 taxa for ITS and *rbcL*. The results suggested that *Psychotria* is broadly paraphyletic. Taxa earlier assigned to *Psychotria*, *Psychotria* sect. *Notopleura* Benth. & Hook. f., and subgenus *Heteropsychotria* Steyerl., plus *Palicourea* were closer to other genera of Psychotrieae than to subgenus *Psychotria*. *Psychotria* was suggested to be restricted to a monophyletic group including two subclades. One subclade is Pacific in distribution and includes the myrmecophytic subtribe Hydnophytineae (including *Hydnophytum*, *Anthorrhiza* C. R. Huxley & Jebb, *Myrmecodia*, *Myrmephytum* Becc.) as a subgroup. The other subclade included *Psychotria* subg. *Psychotria* and subgenus *Tetramerae* E. M. A. Petit. It was also shown that the genus *Declieuxia* was not a member of the Psychotrieae but closer to *Coccosyphum*. Later, Andersson (2002a) sequenced *rps16* for 111 species of the *Psychotria* complex. The result was very much in agreement with Nepokroeff et al.

(1999). Andersson also analyzed a combined data set (the ITS sequences of Nepokroeff et al. [1999] and their *rps16* sequences) for 15 taxa that were shared between the two studies. That analysis resulted in a tree with three well-supported clades, the outgroup (including, e.g., *Carapichea* Aubl., *Chassalia*, *Geophila*, *Hymenocoleus* Robbr., *Notopleura* (Benth. & Hook. f.) Bremek., *Rudgea*, *Palicourea*), two *Psychotria* subclades, *Psychotria* s. str. (– subgenus *Psychotria*, and subgenus *Tetramerae* in Nepokroeff et al. [1999]), and a Pacific subclade (including several *Psychotria* species and also the Hydnophytineae). *Psychotria* s. str. is characterized by usually having pyrenes with or without preformed germination slits (Piesschaert, 2001), a plane or shallowly furrowed adaxial surface, and usually numerous distinct ridges on the abaxial side. Other characters are discussed by Davis et al. (2001). The Pacific clade is characterized by pyrenes with distinct marginal preformed germination slits. The main difference between the studies by Nepokroeff et al. (1999) and Andersson (2002a) is that Nepokroeff et al. included the Pacific clade in *Psychotria* s. str. while Andersson excluded it.

Carapichea was reestablished as a genus by Andersson (2002b) for three species of the *Psychotria* complex in a study based on *rps16* data. Two of the species, *P. borucana* (Ant. Molina) C. M. Taylor & W. C. Burger (= *Cephaelis affinis* Standl.) and *P. ipecacuanha* (Brot.) Stokes, had been shown by Nepokroeff et al. (1999) to be closely related and sister to *Geophila* and *Hymenocoleus*; Andersson (2002b) found a third species, *P. guianensis* Rusby (described as *Carapichea guianensis* Aubl.), that was distant from the *Psychotria* s. str. but belonged to the same group. These three taxa included in the reestablished genus *Carapichea* were strongly supported as a group, but the exact relationship within the *Palicourea* complex was unsupported. The genus was characterized “by having stipules that are not shed by formation of an abscission layer, leaves that dry greenish or greyish, aperturate pollen, and planoconvex pyrenes with an adaxial furrow and preformed germination slits on abaxial ridges, but not along the margins” (Andersson, 2002b: 363).

Phylogeny of the tribe Anthospermeae was estimated based on ITS and *rps16* data by Anderson et al. (2001). They first analyzed a set of taxa, including Anthospermeae together with representatives of other Rubioideae tribes, to test if the tribe was monophyletic. In a second analysis of 25 Anthospermeae taxa (all except two genera of the tribe), they investigated the internal relationships of the genera. Most genera of Anthospermeae formed a monophyletic but

weakly supported clade, with *Carpacoce* Sond. excluded. The latter was instead sister to the Knoxieae. They found no support for a subdivision of the tribe into three subtribes and no support for a subdivision of *Coprosma* into two subgenera. They found support for a clade corresponding to Puff's (1982) subtribe Anthospermeae (*Anthospermum* L., *Nenax*, *Galopina*, and *Phyllis* with *Carpacoce* excluded) and moderate support for Coprosminae (*Coprosma*, *Durringtonia* R. J. F. Hend. & Guym. & Guym., *Leptostigma*, *Nertera*, and *Normandia* Hook. f.—with the latter nested within *Coprosma*), but *Pomax* DC. and *Opercularia* (Puff's subtribe Opercularinae) were placed unresolved in a trichotomy together with the Coprosminae.

Thulin and Bremer (2004) studied parts of the tribe Spermaceae s.l. to circumscribe the genera *Amphiasma* Bremek. and *Pentanopsis* Rendle and to find the affinity of *Phylohydrax* Puff. They analyzed *rbcL* sequences of 34 tribal members and found that the African genera *Amphiasma*, *Conostomium* (Stapf) Cufod., and *Manostachya* Bremek. together with *Phylohydrax* form a strongly supported clade distant from *Hydrophylax* L. f., which was placed close to *Diodia* and *Spermaceae*. When *Phylohydrax* was established as a new genus (Puff, 1986), it was suggested to have evolved from a different stock than the genus *Hydrophylax*. This was also confirmed in a study by Thulin and Bremer (2004). Furthermore, *Amphiasma* was found to be paraphyletic and a new taxonomy was proposed. *Pentanopsis* was circumscribed as a genus of two species from northeastern tropical Africa, whereas *Amphiasma* was treated in its original sense as a genus of about eight species in south-central tropical Africa.

One year after *Phylohydrax* was positioned in the *Amphiasma*–*Conostomium* clade by Thulin and Bremer (2004), Dessein et al. (2005) published a study of *Gomphocalyx* Baker and *Phylohydrax*. They investigated morphology and compared it to results from molecular data (mainly sequences from GenBank). They showed that there are many morphological similarities between the genera, and they concluded, based on the molecular results, “that the character states of the two genera are largely consistent with the here-proposed position in Hedyotideae” (Dessein et al., 2005: 91).

The Andean genus *Arcytophyllum* Willd. ex Schult. & Schult. f. was investigated by *rps16* and *trnL-F* sequences by Andersson et al. (2002). They found support for a monophyletic *Arcytophyllum* (with *A. serpyllaceum* (Schltdl.) Terrell excluded, due to its closer relationship to *Bouvardia*) sister to a clade of American *Hedyotis* L. and *Houstonia* L. species. It is further suggested that these latter should be treated as

a single genus, under the name of *Houstonia*. It was also suggested that the ancestral area of the *Arcytophyllum*–*Houstonia* clade is the South American plate.

Houstonia, a North American genus, was investigated for nuclear (ITS) and chloroplast (*trnL*) sequence variation (Church, 2003). He analyzed *Houstonia* and other closely related genera (*Carterella* Terrell, *Dentella* J. R. Forst. & G. Forst., *Hedyotis*, *Oldenlandia*, *Oldenlandiopsis* Terrell & W. H. Lewis, *Stenaria* (Raf.) Terrell), 30 taxa altogether. The phylogenetic results were compared to chromosome numbers, breeding systems, and life forms. *Houstonia* was not monophyletic and could not be kept distinct from *Stenaria* and North American *Hedyotis*. Within the North American lineage, it appeared that chromosomal changes have had an important role for history of diversification. The annual habit and a homostylous breeding system have originated several times and have probably not been major factors in the radiation of the species. Later, Church and Taylor (2005) investigated a larger set of species and populations (74 populations from 17 species) of the *Houstonia* lineage for ITS, *trnL*, and *trnS-G*. They found no evidence for hybridization in the ancestral species, but more recently derived species contained a wide degree of morphological and genetic variation both within and among species. They found a clear association between hybridization and polyploidy in the *Houstonia* lineage, supporting the idea that polyploidy may break down species barriers and allow hybridization among lineages.

Gaertnera of the tribe Gaertnereae is a Paleotropical genus of regional endemics with its highest diversity on Madagascar (25 species). The genus was investigated by Malcomber (2002; also Malcomber & Davis, 2005). Malcomber (2002) used four usually fast-evolving markers, and the genus was strongly supported as monophyletic. However, the genetic variation among species was insufficient to reconstruct well-supported subgeneric groups “counter to expectations based on the very distinct morphologies and widespread distribution of the genus” (Malcomber, 2002: 42).

The tribe Paederieae was one of the groups studied in a Ph.D. thesis by Backlund (2005). Earlier molecular analyses (Bremer, 1996; Andersson & Rova, 1999) had indicated that the tribe could be polyphyletic, and Backlund (2005) further investigated the tribe in a wide sense and found strong support for Paederieae s. str. (including *Paederia*, *Leptodermis* Wall., *Serissa* Comm. ex Juss., *Spermadictyon* Roxb.) and a reestablished tribe Putorieae.

SUBFAMILY IXOROIDEAE

Andreasen and Bremer (1996) investigated both morphological and molecular (*rbcL*) data of subfamily Ixoroideae s. str. They analyzed 40 ingroup taxa from Gardenieae (*Gardenia* Ellis, *Aidia* Lour., *Alibertia* A. Rich. ex DC., *Burchellia* R. Br., *Calochone* Keay, *Casasia* A. Rich., *Coddia* Verdc., *Didymosalpinx* Keay, *Duperrea* Pierre ex Pit., *Euclinia* Salisb., *Genipa* L., *Glossostipula* Lorence, *Heinsen* K. Schum., *Hyperacanthus* E. Mey. ex Bridson, *Kailarsenia* Tirveng., *Massularia* (K. Schum.) Hoyle, *Mitriostigma* Hochst., *Oxyanthus* DC., *Oxyceros* Lour., *Porterandia* Ridl., *Randia* L., *Rosenbergiodendron* Fagerl., *Rothmannia* Thunb., *Sukunia* A. C. Sm.), Pavetteae (*Pavetta* L., *Dictyandra* Welw. ex Hook. f., *Leptactina* Hook. f., *Rutidea* DC., *Tarenna* Gaertn.), Octotropideae (*Feretia* Delile, *Fernelia* Comm. ex Lam., *Kraussia* Harv., *Paragenipa* Baill., *Pouchetia* DC., *Ramosmania* Tirveng. & Verdc.), and Coffeae (*Coffea*, *Diplospora* DC., *Paracoffea* J.-F. Leroy, *Psilanthus* Hook. f., *Tricalysia* A. Rich. ex DC.) with *Mussaenda* as outgroup. They found that Vanguerieae (*Canthium* Lam., *Vangueria* Juss.) should be included in the subfamily. The Octotropideae, Pavetteae, and Coffeae were monophyletic although with different circumscriptions of the latter two compared to earlier classifications. *Ixora* (together with *Myonima* Comm. ex Juss. and *Versteegia* Valetton) was not part of Pavetteae, and Coffeae should include *Tricalysia* and probably *Bertiera* Aubl. as well. Subtribe Diplosporeinae (*Cremaspora* Benth. and *Tricalysia*) and *Posoqueria* should be excluded from the tribe Gardenieae. Furthermore, they suggested that the informal tetrad group within Gardenieae (Robbrecht & Puff, 1986) is not monophyletic and that the characteristics of the pollen that is released in tetrads may have evolved several times. A few years later, Andreasen et al. (1999) analyzed and compared the utility of the nuclear ITS region with the cpDNA *rbcL* for the Ixoroideae. Variation of ITS was extensive and informative, but the sequences were difficult to align. New phylogenetic positions of taxa (e.g., for *Posoqueria*, *Bertiera*, *Ixora*, and Vanguerieae) that had been reported from the *rbcL* analysis, but contradicted the classification, were corroborated by the ITS data.

Later, Andreasen and Bremer (2000) presented additional analyses of the subfamily based on combinations of *rbcL*, ITS, and restriction fragment length polymorphism (RFLP) data for 77 ingroup taxa. The results agreed with the 1996 and 1999 studies, but many groups received higher support. Further, Alberteae (*Alberta* E. Mey.) was shown to be part of the subfamily, and the mangrove genus *Scyphiphora* C. F. Gaertn. (Antirheoideae fide Robbrecht, 1988; or

Gardenieae s.l. fide Puff & Rohrhofer, 1993) was shown to be close to Ixoreae.

There is strong support for 12 of the 15 investigated tribes of this subfamily as monophyletic (Cremasporae and Retiniphyllae are monotypic or represented by single taxa and could not be tested for monophyly), but the large tribe Gardenieae is polyphyletic/paraphyletic. Despite strong support for the subfamily and the subgroup including Alberteae, Bertiereae, Coffeae, Cremasporae, Gardenieae, Octotropideae, and Pavetteae, most relationships between tribes are unresolved and in need of further research. So far, five Ixoroideae tribes have been studied and are presented below, and several tribes are under investigation. The most important tasks for the future in this subfamily will be to investigate the large complex around the polyphyletic/paraphyletic Gardenieae and to investigate the difficult and large genera *Ixora*, *Pavetta*, and *Tarenna*.

Coffea of the tribe Coffeae has been the focus of several phylogenetic studies (Lashermes et al., 1997; Cros et al., 1998). The phylogeny of *Coffea* was in contradiction to the classification, particularly relative to the genus *Psilanthus*. However, there were correlations between clades and biogeography. It was also shown that *Coffea* has a recent origin and radiation in Africa (Cros et al., 1998).

Dialypetalanthus Kuhl. (without tribal position) is an endemic Amazonian genus that has been treated as a monotypic family Dialypetalanthaceae (Rizzini & Occhioni, 1949), but various affinities have been suggested, e.g., Myrtaceae and Rubiaceae (Kuhlmann, 1925). It is an aberrant genus with free petals and an indefinite, extremely high number of stamens, characters that do not agree with Rubiaceae, but the genus shares many characteristics with taxa of Rubiaceae, e.g., opposite entire leaves with interpetiolar stipules, inferior ovary, bilobed stigma, capsular fruit, and winged seeds. Piesschaert et al. (1997) presented anatomical and morphological data that support an affinity with Gentianales, Rubiaceae in particular. Fay et al. (2000) published the first analysis of molecular (*rbcL*) data in which they showed that the genus belongs to Rubiaceae in the subfamily Ixoroideae s.l., but without tribal position.

Persson (1996) started his studies of tribe Gardenieae with an analysis of 70 morphological and anatomical characters for 81 taxa. Many nodes were unresolved or unsupported, but he found support for several of Robbrecht's and Puff's (1986) informal groups of the Gardenieae (tetrad group and *Alibertia* group, but *Aidia* group and Gardenieae were not supported). Later, Persson (2000a) continued his study of *rps16* and *trnL-F* data for 57 taxa of Gardenieae s.l. to try to resolve the more or less

unresolved phylogeny of the group; he also wanted to evaluate the conflicts between his morphological study (Persson, 1996) and the results from the *rbcL* data (Andreasen & Bremer, 1996). Persson's molecular tree (2000a) was still unresolved, with few supported groups. However, the informal *Alibertia* group (in the study including *Alibertia*, *Amaioua* Aubl., *Borojoa* Cuatrec., *Duroia* L. f., *Glossostipula*, *Ibetrulia* Bremek., *Kutchubaea* Fisch. ex DC., *Melanopsidium* Colla, and *Stachyarrhena* Hook. f.) was well supported (97% bootstrap) and agreed with earlier results (Andreasen & Bremer, 1996; Persson, 1996; Andreasen, 1997). He further identified a core Gardenieae group (*Atractocarpus* Schltr. & K. Krause, *Benkara* Adans., *Catunaregam* Wolf, *Deccania* Tirveng., *Morelia* A. Rich. ex DC., *Sherbournia* G. Don, *Tamilnadia* Tirveng. & Sastre, *Trukia* Kaneh., and *Tarennoidea* Tirveng. & Sastre, among others, but excluding subtribe Diplosporinae, *Burchellia*, *Didymosalpinx*, *Schumanniphyton* Harms, and several taxa belonging to other Ixoroideae tribes) with two subgroups, the *Gardenia* clade and the *Randia* clade. On the other hand, there was no support for an *Aidia* group or for a monophyletic tetrad group (Robbrecht & Puff, 1986), both proposed from morphological data (Persson, 1996). It was further concluded from Persson's molecular data that the pollen release in tetrads had originated several times. It occurs in the large genus *Gardenia*, but not in its close relatives *Aorantho* Somers, *Ceriscoides* (Hook. f.) Tirveng., *Genipa*, and *Kailarsenia* (a clade with 83% bootstrap support); most genera with tetrad pollen occur in a clade of Neotropical genera around *Randia* in which several genera also have monad pollen, e.g., *Rosenbergiodendron*, *Sphinctanthus* Benth., and *Tocoyena* Aubl. Furthermore, outside the core Gardenieae there was also a clade of the genera *Atractogyne* Pierre, *Mitriostigma*, and *Oxyanthus* (86% bootstrap support) with tetrad pollen.

Persson later (2000b) extended his study of the *Alibertia* group (Gardenieae), the group of taxa that "comprises neotropical, dioecious taxa with heteromorous flowers, and monad pollen grains" (Persson, 2000b: 1018). He sequenced two nuclear spacers (ITS and 5S-NTS) for 38 species (of the ca. 120) and found several strongly supported clades in the group. However, *Borojoa* was paraphyletic and nested within *Alibertia* (in a group close to the type species *A. edulis* A. Rich. ex DC.), with *Borojoa* included and *A. hispida* Ducke excluded. *Alibertia* was monophyletic and distinctly divided into two main clades, one including the type species and one around *A. sessilis* (Vell.) K. Schum. In the combined analysis, *Alibertia* was sister to a clade of *Duroia*, with the genus *Amaioua* nested within *Duroia*. *Ibetrulia*, *Kutchubaea*,

and *A. hispida* formed a well-supported clade at the unresolved base of the tree together with the rest of the taxa.

Randia, a genus of ca. 90 Neotropical species, was investigated by Gustafsson and Persson (2002). They studied 38 taxa of the genus together with representatives of eight other Gardenieae genera and analyzed molecular (ITS and 5S-NTS) and morphological data. The molecular data do not support a monophyletic *Randia* but with morphological data added, *Randia*, together with *Casasia*, formed a weakly supported (less than 50%) monophyletic group. Basal to the *Randia*-*Casasia* group is an African clade (*Calochone*, *Macrosphyra* Hook. f., *Oligocodon* Keay, *Preussiodora* Keay) and a *Rosenbergiodendron* clade (*Rosenbergiodendron*, *Sphinctanthus*, *Tocoyena*). Within the *Randia* group, there are three geographically distinct clades: an Andean clade (less than 50% support), Central American *Randia* (58%), and South American *Randia* (85%).

The first attempt to construct a molecular phylogeny of the morphologically distinct tribe Vanguerieae was published by Lantz et al. (2002). They investigated the nuclear spacer ITS for 41 Vanguerieae species representing 19 genera. The taxa fall into several well-supported clades, of which they discussed three informal groups: spiny group (*Canthium*, *Meyna* Roxb. ex Link), *Vangueria* group, and *Fadogia*-*Rytigynia* group. Based on the investigated taxa, *Keetia* E. Phillips, *Lagynias* E. Mey. ex Robyns, *Multidentia* Gilli, and *Pyrostria* Comm. ex Juss. were monophyletic units, but *Canthium*, *Fadogia* Schweinf., *Rytigynia* Blume, *Tapiphyllum* Robyns, and *Vangueria* were found to be polyphyletic or paraphyletic. The analysis clearly demonstrated that several genera are in need of new circumscriptions. Later, Lantz and Bremer (2004) analyzed data for 69 ingroup taxa representing 23 of the 27 genera of the tribe (ITS, *trnT-F*, and morphology). They found strong support for many groups, but these rarely coincided with traditional genera in accordance with their earlier study (Lantz et al., 2002). Of the investigated taxa, *Keetia*, *Lagynias*, and *Multidentia* were monophyletic with strong support and *Psydrax* Gaertn. was monophyletic with weak support. *Canthium* subg. *Afrocanthium* Bridson was given generic status as *Afrocanthium* (Bridson) Lantz & B. Bremer, and also new combinations were made for *Canthium* s. str. Another identified, well-supported clade was the dioecious group, including *Pyrostria* and *Cyclophyllum* Hook. f. and several genera restricted to Madagascar (*Leroya* Cavaco, *Neoleroya* Cavaco, *Peponidium* (Baill.) Arènes, *Pseudopeponidium* Arènes), *Canthium* subg. *Bullockia* Bridson and *Scyphochlamys* Balf. f. The relationships between the

taxa are not well understood and are in need of more study. The earlier proposed spiny group (Lantz et al., 2002) identified by supra-axillary spines was found identical to *Canthium* s. str., and the large-flowered group including *Vangueria* group and *Fadogia*–*Rytigynia* group were further investigated in a later study (Lantz & Bremer, 2005). Sixty-six of the estimated ca. 180 species were analyzed for the nuclear ITS and the chloroplast markers *trnT-F* and *rps16*. The data were analyzed in combination and separately. Several taxa (*Ancylanthos rubiginosus* Desf., *Hutchinsonia barbata* Robyns, *R. beniensis* (De Wild.) Robyns, *R. decussata* (K. Schum.) Robyns, and *R. eickii* (K. Schum. & K. Krause) Bullock) had incongruent positions in the different analyses and hybridization, and introgression was proposed as an explanation for the incongruence. These taxa were excluded from the taxonomic discussions. Both the *Vangueria* and *Fadogia*–*Rytigynia* groups were supported as monophyletic entities. Most of the taxa of the *Vangueria* group were merged into *Vangueria* (the genera *Ancylanthos* Desf., *Lagynias*, *Pachystigma* Hochst., *Tapiphyllum*, and a few investigated species of *Fadogia* and *Rytigynia*). The genus is characterized in the tribe by domatia rarely present, inflorescences usually borne at nodes from which the leaves have fallen, smooth retrorse hairs in the corolla, and large fruits (more than 1 cm long) with three to five locules. The relationships within the *Fadogia* and *Rytigynia* group could not be resolved and are in need of further study. However, the whole group could be distinguished from the *Vangueria* group by presence of domatia and a calyx with or without poorly developed calyx lobes (with exceptions).

Taxa of the tribes Mussaendeae, Isertieae (see under Cinchonoideae), and Sabiceae have been understood as a complex even before molecular data came into use, but are treated differently by different authors (e.g., Bremekamp, 1966; Robbrecht, 1988; Andersson, 1996). In a study of *rbcL* data from Cinchonoideae and Ixoroideae taxa by Bremer and Thulin (1998), Isertieae was found to be a small tribe close to Cinchoneae of the subfamily Cinchonoideae; however, Sabiceae and Mussaendeae are two tribes that belong to subfamily Ixoroideae. A new aberrant endemic genus from Socotra, *Tamridaea* Thulin & B. Bremer, was shown to be a sister genus to *Virectaria* Bremek. and placed in Sabiceae together with *Sabicea* Aubl. and *Pseudosabicea* N. Hallé. The tribe Mussaendeae was reestablished, and *Mussaenda*, *Aphaenandra* Miq., *Heinsia* DC., and *Pseudomussaenda* Wernham were included as the component genera.

Alejandro et al. (2005) later investigated tribe Mussaendeae and tested the monophyly of the genus *Mussaenda* and the circumscription of Mussaendeae

sensu Bremer and Thulin (1998; see under Isertieae–Cinchonoideae). Alejandro et al. included 25 species (of ca. 160) of *Mussaenda* and representatives of all genera of the tribe, except for *Neomussaenda* Tange, plus outgroups (the genus *Mussaendopsis* Baill. was also included, which was shown to belong to the Condamineae clade). They analyzed *trnT-F* and ITS data and demonstrated that the tribe Mussaendeae (including *Mussaenda*, *Aphaenandra*, *Bremeria* Razafim. & Alejandro, *Heinsia*, *Landiopsis* Bosser, *Pseudomussaenda*, and *Schizomussaenda* H. L. Li) is monophyletic, but the genus *Mussaenda* s.l. is polyphyletic. The Malagasy species were found to be more closely related to *Landiopsis* than to the African and Asian *Mussaenda*. They described a new genus *Bremeria* to accommodate 19 Indian Ocean species. The recircumscribed *Mussaenda* is characterized by reduplicate valvate aestivation and glabrous styles, in contrast to the reduplicate and induplicate aestivation and densely pubescent styles in *Bremeria*.

Dessein et al. (2001) published a study of *Hekistocarpa* Hook. f. and showed that it belongs in the vicinity of *Virectaria*. They also performed jackknife analyses of two molecular data sets, one of *rbcL* and one of *rps16* (mainly sequences from GenBank). Their conclusions from the molecular analysis and the morphological investigation were that the emended tribe Sabiceae of Bremer and Thulin (1998) could not be morphologically characterized and is better treated as two distinct tribes: (1) Sabiceae (*Sabicea* and *Pseudosabicea* and also, although not included in the analyses, *Ecpoma* K. Schum., *Pentaloncha* Hook. f., and *Stipularia* P. Beauv.); and (2) Virectarieae (including *Virectaria*, *Hekistocarpa*, and *Tamridaea*). In a sense, the Sabiceae is characterized by entire stipules, medium to large flowers, valvate aestivation, berries, and small angular seeds with thickened radial walls. According to Dessein et al. (2001: 75), it is more difficult “to diagnose the tribe Virectarieae emended to include *Hekistocarpa* and *Tamridaea*.”

Stimulated by the results from Rova et al. (2002), Delprete and Cortés-B. (2004) carried out a more detailed molecular analysis (*trnT-F* and ITS) of tribe Sipaneeae with *Platycarpum* Humb. & Bonpl. as the outgroup and evaluated relationships and delimitations of genera. They confirmed that the tribe is monophyletic and belongs within the Ixoroideae. In the tribe, they included *Sipanea*, *Chalepophyllum* Hook. f., *Dendrosipanea* Ducke, *Limnosipanea* Hook. f., *Maguireothamnus*, *Neobertiera*, and *Sipaneopsis* Steyerf. All genera investigated were found to be monophyletic. It was inferred that the herbaceous habit of *Sipanea* and *Limnosipanea* had evolved twice in the tribe as these two genera are not sister groups. Delprete and Cortés-B.

(2004) had no material of *Neblinathamnus* Steyerm., *Pteridocalyx* Wernham, and *Steyermarkia* Standl., but, due to morphological similarities, they tentatively included these in the Sipaneeae.

SUBFAMILY CINCHONOIDEAE

No study has focused explicitly on the entire subfamily Cinchonoideae, but several studies on the whole family (Bremer et al., 1995; Rova et al., 2002) or of specific groups (Bremer & Thulin, 1998; Razafimandimbison & Bremer, 2001; Andersson & Antonelli, 2005) have contributed to the knowledge of the subfamily. Based on these studies, there is support for nine tribes: Cinchoneae, Chiococceae, Guettardeae, Hamelieae, Hillieae, Hymenodictyeae, Iserctieae, Naucleaeae, and Rondeletieae, six of which are discussed below. The relationships between the tribes in this subfamily are very poorly understood, except for a few sister group relations between Guettardeae and Rondeletieae, Hamelieae and Hillieae, and Hymenodictyeae and Naucleaeae, respectively. Most species of *Rondeletia*, the largest genus of this subfamily, have not been investigated so far. It would be interesting to analyze all species in this mainly South American subfamily, particularly because there are several interesting biogeographic patterns of relations between South America and the Old World tropics, the Pacific, and the Caribbean.

Early molecular data (Bremer & Jansen, 1991) indicated the tribe Chiococceae (Antirheoideae fide Robbrecht, 1988) to be close to parts of Condamineae and Cinchoneae. Based on that indication, Bremer (1992) analyzed 20 morphological characters for 22 genera of Chiococceae and the *Portlandia* P. Browne group, and, as a result, the tribe Chiococceae was emended to include also subtribe Portlandiinae (Condamineae) and some taxa of Cinchoneae, as there was no resolution or support for two distinct clades corresponding to Chiococceae s. str. and a *Portlandia* group.

In his study, Delprete (1996) reexamined the circumscription of the Condamineae, Chiococceae, and Catesbaeeae (Delprete, 1996: 165), with the purpose "to test the tribal redefinition of Chiococceae proposed by Bremer (1992)." He analyzed 170 species of 44 genera for 44 morphological characters. His conclusion was that the *Portlandia* group (former Condamineae) is closer to the Chiococceae s. str. (as suggested by Bremer, 1992) than to the rest of the Condamineae. Because Chiococceae s. str. was monophyletic without the *Portlandia* group, he retained Chiococceae as a restricted tribe and instead included the *Portlandia* group in the tribe Catesbaeeae. Therefore, the rest of the Condamineae

(Condamineinae and Pinckneyinae) was merged with the Rondeletieae s.l.

In several later molecular studies, the circumscription of the two tribes by Delprete (1996) was contradicted, and it has instead been shown that all taxa are intermixed in one group approximately corresponding to an emended Chiococceae (Bremer et al., 1995; Andersson & Rova, 1999; Rova et al., 2002). Motley et al. (2005) investigated most of the genera from the Catesbaeeae–Chiococceae complex to reevaluate the generic relationships. They found strong support for a group with *Strumpfia* Jacq. as sister to the complex, but there was no support to separate the taxa into two clades or tribes. They found *Catesbaea* L., *Erithalis*, *Hintonia*, *Isidorea* A. Rich. ex DC., *Phialanthus*, *Portlandia*, and *Scolosanthus* Vahl to be monophyletic genera, but *Bikkia* Reinw., *Chiococca*, *Exostema*, and *Solenandra* Hook. f. are paraphyletic/polyphyletic, and for several taxa, monophyly could not be tested (monotypic genera or single species investigated; *Asemnantha* Hook. f., *Badusa* A. Gray, *Ceratopyxis* Hook. f., *Coutaportla*, *Coutarea*, *Cubanola* Aiello, *Morierina* Vieill., *Osa* Aiello, *Phyllacanthus*, *Salzmannia* DC., *Schmidtottia*, and *Siemensia* Urb.).

Exostema, a genus of 25 species that occurs from Bolivia to Mexico throughout the West Indies, represents one of the first molecular analyses of a genus within Rubiaceae. McDowell and Bremer (1998) investigated all species for 37 morphological characters and ITS sequences of 18 species. All data sets (morphology, molecular, and combined) resolved three main species groups corresponding to sections earlier proposed by McDowell (1996). However, the ITS and combined trees placed the two South American species (*E. corymbosum* (Ruiz & Pav.) Spreng. and *E. maynense* Poepp. & Endl.) basal to the three retrieved clades. The genus was later reinvestigated by McDowell et al. (2003), who used *rbcL*, ITS, and combined data in order to understand the biogeographic pattern of the genus in the Caribbean region. The analyses were based on 14 *Exostema* species and nine species from eight related genera. The data did not support *Exostema* as monophyletic. In the ITS analysis, which showed the best resolved trees, *Coutarea*, *Chiococca*, and *Erithalis* were nested within *Exostema*, making *Exostema* highly polyphyletic or paraphyletic. *Coutarea* (from South or Central America) was placed close to the two South American species of *Exostema* (*E. corymbosum* and *E. maynense*).

Erithalis is an endemic Caribbean genus, the phylogeny and biogeography of which were studied by Negrón-Ortiz and Watson (2002). They investigated seven of the eight to 10 species with two nuclear

markers, ITS and ETS. They found the genus to be monophyletic relative to the genus *Chiococca* and *Exostema longiflorum* (Lamb.) Roem. & Schult. Surprisingly, there was no support for monophyly for any of those species (*Erithalis fruticosa* L., *E. salmeoides* Correll, *E. odorifera* Jacq.) that were sampled from more than one specimen. Due to low variation in the molecular markers, they hypothesized that the genus radiated rapidly within the Caribbean islands and that an initial colonization may have been from Central America.

Tribe Cinchoneae and the complex around this tribe were first analyzed with morphological characters by Andersson and Persson (1991) and Andersson (1995). They found the tribes Cinchoneae, Hillieae, and Calycophylleae to be monophyletic, and they proposed new circumscriptions of these tribes. However, the morphological tree showed many incongruent relationships compared to later molecular analyses (Razafimandimbison & Bremer, 2001, 2002; Rova et al., 2002). More recently, Andersson and Antonelli (2005) reinvestigated the relationships of the Cinchoneae, making a thorough analysis based on five molecular markers for 51 Rubiaceae taxa sampled from the Cinchoneae and closely allied tribes (Chiococceae, Guettardeae [*Guettarda*], Hamelieae, Hillieae [*Cosmibuena* Ruiz & Pav.], Isertieae [*Isertia* Schreb., *Kerianthera* J. H. Kirkbr.], Naucleaeae, Rondeletieae) as well as other representatives of the family. They found the tribe to be strongly supported as monophyletic including the monophyletic genera *Cinchona* L., *Cinchonopsis* L. Andersson (monotypic), *Joosia* H. Karst, *Ladenbergia* Klotzsch, *Remijia* DC., and *Stilpnophyllum* Hook. f. The monotypic *Pimentelia* Wedd. was not investigated, but due to morphological similarities, it was suggested to be close to *Stilpnophyllum*. Further, Antonelli (in Andersson & Antonelli, 2005) described a new genus *Ciliosemina* Antonelli within the tribe, including two species (former species of *Cinchona*/*Ladenbergia*/*Remijia*) characterized by “long-pedunculate, corymbose or subcorymbose inflorescences (fig. 3A), and the ciliate to fimbriate wing margins of its seeds” (Andersson & Antonelli, 2005: 26).

Tribe Isertieae was first analyzed by Andersson (1996) with morphological data. He investigated all except one of the Isertieae genera enumerated by Robbrecht (1988), 26 genera total with representatives of other tribes. The analyses resulted in a new circumscription of the tribe including only seven genera: *Isertia* (including *Yutajea* Steyererm.), *Aphaenandra*, *Heinsia*, *Mussaenda*, *Neomussaenda*, *Pseudomussaenda*, and *Schizomussaenda*. Andersson recircumscribed tribe Sabiceae to include *Sabicea*, *Acranthera* Arn. ex Meisn., *Amphidasya*, *Ecpoma*,

Pentaloncha, *Pittierothamnus* Steyererm., *Pseudosabicea*, *Schizostigma* Arn. ex Meisn., and *Temnopteryx* Hook. f.

Molecular data showed contradicting circumscriptions of Isertieae, tested the phylogeny presented by Andersson (1996), and also pinpointed the position of an aberrant endemic species from Socotra. Bremer and Thulin (1998) investigated *rbcL* for Cinchonoideae and Ixoroideae taxa plus seven outgroups. Their conclusion was that Isertieae belongs to the Cinchonoideae but should be restricted to *Isertia* (including *Yutajea*) and *Kerianthera*, and that Sabiceae and Mussaendeae instead belong to Ixoroideae.

Tribe Naucleaeae s.l. was investigated by Razafimandimbison and Bremer (2001, 2002). They investigated molecular (ITS, *rbcL*, *trnT-F*) and morphological characters for a total of ca. 50 taxa of the tribe in the different analyses that represented most genera. They showed that a broader circumscription of the tribes, including not only Naucleaeae sensu Ridsdale but also *Cephalanthus* L. (of Antirheoideae fide Robbrecht, 1988) and *Mitragyna* Korth. and *Uncaria* Schreb. (of Cinchoneae fide Robbrecht, 1988), belong to the group. They also showed that *Coptosapeltea* sensu Andersson and Persson (1991) is paraphyletic. Twenty-four genera were accepted in Naucleaeae, which was divided into six highly supported and morphologically distinct subtribes (Breoniinae: *Breonadia* Ridsdale, *Breonia* A. Rich. ex DC., *Gyrostipula* J.-F. Leroy, *Janotia* J.-F. Leroy; Cephalanthinae: *Cephalanthus*; Corynantheinae: *Corynanthe* Welw., *Pausinystalia* Pierre ex Beille, *Pseudocinchona* A. Chev. ex Perrot; Naucleinae: *Nauclea* L., *Burttdavaya* Hoyle, *Ochreinauclea* Ridsdale & Bakh. f., *Neolamarckia* Bosser, *Sarcocephalus* Afzel. ex R. Br.; Mitragyninae: *Mitragyna*; and Uncarinae: *Uncaria*) and one paraphyletic or poorly supported subtribe Adininae (*Adina* Salisb., *Adinauclea* Ridsdale, *Haldina* Ridsdale, *Ludekia* Ridsdale, *Metadina* Bakh. f., *Myrmeconuclea* Merr., *Neonauclea* Merr., *Pertusadina* Ridsdale, *Sinoadina* Ridsdale). The *Neonauclea* clade, part of the subtribe Adinae, with many myrmecophytic taxa (see below) was further investigated in a study by Razafimandimbison et al. (2005). They analyzed ITS and ETS and found the *Neonauclea* clade well resolved and supported; *Ludekia* is sister to the two monophyletic genera *Myrmeconuclea* and *Neonauclea* (the latter were earlier suggested to be paraphyletic; Razafimandimbison & Bremer, 2002).

A new tribe Hymenodictyeae, sister group to the Naucleaeae, was described for *Hymenodictyon* Wall. and *Paracorynanthe* Capuron (Razafimandimbison & Bremer, 2001). The two genera *Paracorynanthe* (two species) and *Hymenodictyon* (22 species) are distrib-

uted in Madagascar, and in Madagascar, mainland Africa, and tropical Asia, respectively. The sister group relationship to Naucleaeae is highly supported (Razafimandimbison & Bremer, 2001).

Neolaugeria Nicolson of the tribe Guettardeae, endemic to the West Indies, was studied by Moynihan and Watson (2001). Their data supported the genus of three species as monophyletic, but it was found to be only distantly related to *Stenostomum* C. F. Gaertn., a genus with which *Neolaugeria* sometimes has been merged as a section. Instead, it was closer to *Timonius* DC., although the support was very low. Moynihan and Watson (2001) also tested an earlier hypothesis regarding the origin of the genus in the Lesser Antilles by comparing vicariance with long-distance dispersal. The conclusion, albeit also with low support, was that *N. resinosa* (Vahl) Nicolson may occupy a basal phylogenetic position, supporting a pattern of speciation and colonization in a northwesterly direction from Lesser Antilles to the Greater Antilles and the Bahamas.

APPLIED STUDIES BASED ON RUBIACEAE PHYLOGENIES

The power of a phylogenetic tree is not only that it can be used for classification and systematics, but that it can be used for studies of diversity, anatomy, morphology, biogeography, ecology, etc., in which evolution of taxa, genes, and characters can be used in a comparative context. With this species-rich and diverse family and with more and better phylogenetic trees from the family, we can probably foresee a strong increase in studies based on phylogenetic trees. So far, we have only seen a limited number of such studies, with interesting evolutionary questions being addressed.

PHYLOGENETIC TREES FOR ECOLOGICAL, EVOLUTIONARY, OR BIOGEOGRAPHICAL QUESTIONS

In 1991 and 1992, the first phylogenetic ecology papers were published (Eriksson & Bremer, 1991; Bremer & Eriksson, 1992) in which a Rubiaceae phylogeny was used. These studies addressed hypotheses about evolution of fruit traits, animal versus abiotic modes of dispersal, life forms, and species richness. It was shown that fleshy fruits have evolved several times and that in many lineages the animal-dispersed fruits (drupes and berries) have remained largely unaltered since the time of origin. This is in contrast to the evolution of lineages with wind-dispersed seeds in capsules, or with pterophylls promoting wind dispersal of fruits, where traits have shifted more frequently during evolution. Animal dispersal was widespread among shrubs, whereas

abiotic dispersal was most prevalent among herbs. Drupes were common in transoceanic taxa and on islands, indicating dispersal over long distances, probably by birds, but no evidence supported the view that animal dispersal in general enhances long-distance dispersal. No single trait explained variation in species richness. Instead, certain combinations of dispersal mode or life forms were shown to be associated with species richness. Genera with herbs and with abiotic dispersal, or with shrubs and with animal dispersal, or with shrubs and trees with winged seeds were all characterized by large species numbers, a result that implies association between seed dispersability and rate of species diversification.

High host specificity of herbivorous insects and global estimates of diversity have been much discussed (cf. Erwin, 1982; Stork, 1993; Odegaard, 2000). Novotny et al. (2002) compared a plant phylogeny of 51 tree species, including Rubiaceae, from New Guinea with more than 900 leaf-chewing insects found on these plants. Compared to earlier, more theoretical studies, they found low host specificity of the tropical herbivorous insects, and, as a consequence, a global estimate on arthropod diversity was reduced from 31 million to 4 to 6 million species.

Razafimandimbison et al. (2004) identified high polymorphism of the ITS region in three Naucleaeae species (*Adinauclea fagifolia* (Teijsm. & Binn. ex Havil.) Ridsdale, *Haldina cordifolia* (Roxb.) Ridsdale, and *Mitragyna rubrostipulata* (K. Schum.) Havil.). They found both intra-individual and intraspecific polymorphism in the three species, but no such variation in the other 22 investigated species of the same tribe. Most of the variants were putative pseudogenes. They explored the potential utility of pseudogenes in a phylogenetic analysis and found that the polymorphism does not transcend species boundaries in this group (all variants within a species come together in the tree), so any of the pseudogenes could be of use in a phylogenetic analysis without contradicting the phylogenetic signal.

McDowell and Bremer (1996) used a tree of *Exostema* (see above under *Exostema*) to optimize and investigate major trends in morphological diversification of the genus, e.g., attributes for specializations to a xeric environment and for pollination biology. Xeromorphic traits had evolved in all three lineages, e.g., reduction of vegetative characters, and also reduction of reproduction traits such as seed size and seed numbers. In the genus, two different major pollination syndromes occur, a long-flowered moth (*Lepidoptera*) type and a short-flowered bee pollination type. According to the analyses, both of these pollination

types (with characteristic flower lengths, flower numbers, and corolla color) have evolved more than once.

Evolution of myrmecophytism was investigated in a study by Razafimandimbison et al. (2005). This biologically interesting ant-plant association occurs in 22 genera and ca. 140 species of Rubiaceae, most of these in Southeast Asia, especially in the Malesian region. Razafimandimbison et al. investigated the *Neonauclea* clade of Naucleaceae, including 25 taxa with myrmecophytism. Based on the molecular phylogeny, they concluded that multiple origins of myrmecophytism occurred in Borneo and that the low level of genetic variation indicates a rapid radiation in the *Neonauclea* (65 species); low radiation in *Myrmeconuclea* (3 species) was explained by the different fruit and seed types and the ability to colonize different habitats.

In their study of the Catesbaeeae–Chiococceae complex, Motley et al. (2005) reconstructed flower and fruit evolution and discussed biogeographic hypotheses for the disjunction between the Caribbean and Pacific genera. According to their optimization on the tree, the ancestral fruit type for the group seems to be capsular; drupaceous fruits seem to have evolved twice and baccate fruits once or twice. The three types of flowers more or less correspond to hypothesized pollinators: *Exostema* type by moths and butterflies, *Chiococca* type by bees, and *Portlandia* type by birds and bats. All types have evolved three or more times. Motley et al. (2005) also concluded that fleshy fruits have been very successful in dispersing between the Caribbean islands, and wind-dispersed seeds of the capsular-fruited taxa have been more successful for long-distance dispersal over the Pacific Ocean.

The first biogeographic analysis of the family was based on a phylogeny of Anthospermeae (Anderson et al., 2001). The biogeographic implications were that the ancestral area of the tribe is Africa (including Madagascar) and that the genus spread by long-distance dispersal to northeastern Antarctica. It was also suggested that the occurrences in America, Hawaii, and Tristan da Cunha are due to long-distance dispersal.

Other publications that discuss the biogeography of Africa are Malcolmer's (2002) *Gaertnera* study and Alejandro et al.'s (2005) study of *Mussaenda*. Malcolmer (2002) proposed that *Gaertnera* migrated to Africa during the early Tertiary, possibly via a boreotropical land bridge, and he further suggested that the genus started to radiate about 5.2 million years ago (Ma). The range of distribution is explained by a number of long-distance dispersal events. The molecular clock estimate gave a rapid diversification rate of 0.717 to 0.832 species/million years, which is comparable to estimates of radiation on Oceanic

islands. Alejandro et al. (2005) concluded that *Mussaenda* s. str. has an African origin and that the Asian *Mussaenda* species descended from an African species that migrated to Asia, where the major radiation has occurred (now 97 of 132 species). Despite the close phylogenetic relationship between the African and Asian clades, not one species occurs on both continents. One of the most widespread African *Mussaenda* species, *M. arcuata* Poir., has reached the Comoro Islands, Madagascar, and Mascarenes as suggested probably via stepping-stone dispersal.

Nepokroeff et al. (2003) investigated the phylogeny and biogeography of the Hawaiian species of *Psychotria* to reconstruct the ancestral pattern of colonization and dispersal. Both parsimony and likelihood analysis gave highly congruent results, except for one internal node. They investigated all 11 species from Hawaii together with eight extra-Hawaiian species. The analysis strongly supported the Hawaiian taxa as monophyletic and descended from a single introduction to the islands. The genus *Kelloggia*, with disjunct distribution in western North America and the western part of eastern Asia, was investigated by Nie et al. (2005), who found that the two species diverged from each other about 5.4 Ma; dispersal-vicariance analysis (DIVA) suggested an Asian origin of *Kelloggia*. Nie et al. (2005) further suggested that the disjunct distribution is a result of long-distance dispersal from Asia into western North America.

From the Caribbean region, Negrón-Ortiz and Watson (2003) used the phylogenies of the two endemic genera *Erithalis* (Negrón-Ortiz & Watson, 2002) and *Ernodea* (Negrón-Ortiz & Watson, unpubl. data) in a biogeographic study using Brooks Parsimony Analysis (BPA) and Fitch parsimony methods. They found a biogeographic association between Cuba and the Dominican Republic, but the two countries of Hispaniola (Dominican Republic and Haiti) were found in two places in the cladogram, suggesting Hispaniola to be a composite of geologic areas. The Fitch analyses also supported a Greater Antillean origin for *Erithalis*, in contrast to the Negrón-Ortiz and Watson (2002) article in which they suggest colonization of the genus from Central America. The present distribution of the two genera was explained as a product of dispersal for *Ernodea* and by a combination of vicariance and dispersal events for *Erithalis*. The mainly Caribbean genus *Exostema* (McDowell et al., 2003) has also been analyzed biogeographically, but its distribution pattern was found to be far more complex than anticipated and no clear conclusions could be drawn except for a close affinity between the Cuban and Hispaniolan groups.

UNDERSTANDING DISTRIBUTION AND EVOLUTION OF
MORPHOLOGICAL, ANATOMICAL, AND CHEMICAL CHARACTERS
THROUGH PHYLOGENETIC TREES

Molecular phylogenies have also been very useful for understanding morphological, anatomical, or chemical traits in various parts of the family. Jansen et al. (2001) performed a large survey of anatomical characters of woody Rubioideae taxa and compared the characters with recent phylogenetic insights in the study group on the basis of molecular data. The idea of the study was based on results from molecular phylogenetic analysis, even if this was not stated explicitly. Jansen et al. (2001) presented anatomical data in illustrations and in a table of 26 different characters for 23 genera (and ca. 70 species) representing woody taxa of Coccocypseleae, Coussarieae, *Lasianthus* group, Morindeae s.l., Pauridiantheae, Trianolepideae, and Urophyllaeae. It would have been even more interesting with a phylogenetic analysis of the morphological data or a combined morphological-molecular analysis, but their results nevertheless seem to be in agreement with most phylogenetic hypotheses presented from molecular data. Soon thereafter, Jansen et al. (2002) presented a survey of wood anatomy of the whole family. They optimized the characters on a hypothetical supertree and found that the wood characters agreed with the phylogeny. Furthermore, they found that fiber types and axial parenchyma distribution, for example, indeed had good taxonomic values in the family, but they concluded that wood anatomical data in Rubiaceae is more useful in confirming or negating already proposed relationships rather than postulating new affinities for problematic taxa (Jansen et al., 2002).

Pollen morphology was investigated in 29 species of northwestern European representatives of Rubieae (*Rubia*, *Asperula*, *Crucianella*, *Cruciata*, *Galium*, *Sherardia*) by Huysmans et al. (2003). They found the combination of pollen characteristics to be unique within the family: several colpate apertures, a perforate and microechinate tectum, a relatively small size, absence of endoapertures, a coarse nexine area beneath the ectocolpi, and absence of orbicules. The tribe Gardenieae also lacks orbicules (Huysmans et al., 1998, 2000). Huysmans et al. (2003) further optimized presence and absence of endoapertures on a Rubioideae tree from Bremer and Manen (2000) and showed that only the Paederieae/Theligoneae/Rubieae totally lack the endoapertures, while the character is variable in Argostemmataeae.

Jansen et al. (2003) measured concentration of several metals in Rubiaceae. The most characteristic pattern was for aluminium, and there was also a

correlation with occurrence of silicon but not with any other metals. The aluminium accumulation was optimized on a molecular phylogenetic tree, and it was most characteristic of Rubioideae but occurs also in *Coptosapelta* and is partly present in taxa of Vanguerieae and Alberteae.

There are a few examples of surveys of various traits from the family, chemical and morphological data, in which no tree approach has been used but for which analyses in relation to a phylogenetic tree would be very interesting. At the first Rubiaceae conference, Kiehn presented (1995) a survey of chromosome numbers of the family. Although he did not optimize his characters on a molecular phylogeny, many interesting results corroborate the molecular hypothesis about relationships, e.g., a close association of Hedyotideae and Spermaceae (as in Bremer et al., 1995; Natali et al., 1995).

Wichman et al. (2002) investigated a set of 50 individuals representing 36 taxa of *Coprosma* from New Zealand. They investigated patterns of hybridization and genotype mixing in ITS and ETS sequences. They found high intra-individual heterogeneity, and the conclusion was that the widespread occurrence of sequence mixture was a result of frequent hybridization in the genus. They also suggested that concerted evolution in the genus is depressed and that the mechanisms evolved to maintain a high level of heterogeneity as an adaptive value for *Coprosma* in the climatically unstable and physically complex New Zealand landscape. The authors have sequenced many taxa, but they have not performed any phylogenetic analysis. It would be very interesting to investigate patterns of suggested hybridization in a phylogenetic framework.

Mitova et al. (2002) analyzed iridoid patterns within *Galium* with some phylogenetic considerations. They found differences in iridoid compounds and identified three lines of evolution: one that led to *G. rivale* (Sibth. & Sm.) Griseb., a second that included *G. mollugo* L. and the *G. incurvum* group, and a third that included the rest of the studied species (e.g., *G. palustre* L., *G. odoratum* (L.) Scop.). The study could be much improved if sampling and discussion are based on available phylogenetic data of the group (e.g., Natali et al., 1996).

Recently, Mongrand et al. (2005) investigated 107 Rubiaceae species for composition of leaf fatty acids. They used principal component analysis (PCA) and identified the tribes Coffeeae, Psychotrieae, and Rubieae from their data. It is difficult to see how informative these chemical characters are as the PCA only shows similarities between species, which can completely contradict a phylogenetic relationship; furthermore, the results are compared to a nonphylo-

genetic tribal classification (Robbrecht, 1993), so it is unfortunately very difficult to draw any conclusions about evolution and relationships of the fatty acids.

Since the present review of molecular phylogenetic studies of Rubiaceae was presented at the Third International Rubiaceae Conference in 2006, ca. 10 more molecular phylogenetic studies of Rubiaceae have been published. They are not reviewed in this article, but the most important are as follows. Robbrecht and Manen (2006) have presented a super-tree construction of the family Rubiaceae. Several detailed studies of tribes have been published, e.g., Coffeae (Davis et al., 2007), Knoxieae (Kårehed & Bremer, 2007), Paederieae, Putorieae (Backlund et al., 2007), and Urophylleae (Smedmark et al., 2008). Further, molecular studies of enigmatic or problematic genera have been presented, e.g., *Acranthera* (Rydin et al., 2009), *Coffea* (Maurin et al., 2007), *Guettarda* (Achille et al., 2006), *Psychotria* (Sohmer & Davis, 2007), and *Ropalobrachium* (Mouly et al., 2007).

From the ca. 50 molecular studies of the family reviewed in this article, we now have a good framework of the phylogeny of the family. We know that Rubiaceae are monophyletic and there is high support for three subfamilies (Cinchonoideae, Ixoroideae, Rubioideae) and over 40 tribes. Of these tribes, four are monogeneric (Cremasporeae, Retiniphyllae, Schradereae, and Theligoneae). Two tribes, Gardenieae and Morindeae, are paraphyletic/polyphyletic. At the base of Rubiaceae, there is a trichotomy between *Luculia* and Coptosapelteae, a clade including subfamilies Cinchonoideae and Ixoroideae, and a third clade including subfamily Rubioideae. These three clades and the two clades corresponding to Cinchonoideae and Ixoroideae are highly supported. Subfamily Cinchonoideae includes nine tribes. Most interrelationships between these are unresolved. Subfamily Ixoroideae includes two monogeneric tribes (Retiniphyllae, Cremasporeae), 12 well-supported clades corresponding to tribes, and also several taxa referred to as a polyphyletic/paraphyletic tribe Gardenieae. Subfamily Rubioideae includes two monogeneric tribes (Schradereae, Theligoneae), 15 supported clades corresponding to tribes, and also taxa of a paraphyletic/polyphyletic tribe Morindeae. Despite all these studies, there are still many problems to be investigated in Rubiaceae phylogeny. Only half of the tribes have been the focus of specific studies, and the large problematic genera are still in need of much investigation, e.g., *Psychotria*, *Galium*, *Ixora*, *Pavetta*, *Ophiorrhiza*, and *Palicourea*. Evolutionary investigations, biogeography, species richness, morphological traits, and other studies in Rubiaceae have just started, and with the diversity and disparity of the family, we can foresee an increased interest in the family and its phylogeny.

Literature Cited

- Achille, F., T. J. Motley, P. P. Lowry II & J. Jérémie. 2006. Polyphyly in *Guettarda* L. (Rubiaceae, Guettardeae) based on nrDNA ITS sequence data. *Ann. Missouri Bot. Gard.* 93: 103–121.
- Alejandro, G. D., S. G. Razafimandimbison & S. Liederschumann. 2005. Polyphyly of *Mussaenda* inferred from ITS and *trnT-F* data and its implication for generic limits in Mussaendeae (Rubiaceae). *Amer. J. Bot.* 92: 544–557.
- Anderson, C. L., J. H. E. Rova & L. Andersson. 2001. Molecular phylogeny of the tribe Anthospermeae (Rubiaceae): Systematic and biogeographic implications. *Austral. Syst. Bot.* 14: 231–244.
- Andersson, L. 1995. Tribes and genera of the Cinchoneae complex (Rubiaceae). *Ann. Missouri Bot. Gard.* 82: 409–427.
- . 1996. Circumscription of the tribe Isertieae (Rubiaceae). *Opera Bot. Belg.* 7: 139–164.
- . 2002a. Relationships and generic circumscription in the *Psychotria* complex (Rubiaceae, Psychotrieae). *Syst. & Geogr. Pl.* 72: 167–202.
- . 2002b. Re-establishment of *Carapichea* (Rubiaceae, Psychotrieae). *Kew Bull.* 57: 363–374.
- & A. Antonelli. 2005. Phylogeny of the tribe Cinchoneae (Rubiaceae), its position in Cinchonoideae, and description of a new genus, *Ciliosemina*. *Taxon* 54: 17–28.
- & C. Persson. 1991. Circumscription of the tribe Cinchoneae (Rubiaceae)—A cladistic approach. *Pl. Syst. Evol.* 178: 65–94.
- & J. H. E. Rova. 1999. The *rps16* intron and the phylogeny of the Rubioideae (Rubiaceae). *Pl. Syst. Evol.* 214: 161–186.
- , ——— & F. A. Guarin. 2002. Relationships, circumscription, and biogeography of *Arcytophyllum* (Rubiaceae) based on evidence from cpDNA. *Brittonia* 54: 40–49.
- Andreasen, K. 1997. Phylogeny of Ixoroideae. Ph.D. Dissertation, Uppsala University, Uppsala.
- & B. Bremer. 1996. Phylogeny of the subfamily Ixoroideae (Rubiaceae). *Opera Bot. Belg.* 7: 119–138.
- & ———. 2000. Combined phylogenetic analysis in the Rubiaceae-Ixoroideae: Morphology, nuclear and chloroplast DNA data. *Amer. J. Bot.* 87: 1731–1748.
- , B. G. Baldwin & B. Bremer. 1999. Phylogenetic utility of the nuclear rDNA ITS region in subfamily Ixoroideae (Rubiaceae): Comparisons with cpDNA *rbcL* sequence data. *Pl. Syst. Evol.* 217: 119–135.
- Axelius, B. 1990. The genus *Xanthophytum* (Rubiaceae)—Taxonomy, phylogeny, and biogeography. *Blumea* 34: 425–497.
- Backlund, M. 2005. Phylogenetic Studies in the Gentianales—Approaches at Different Taxonomic Levels. Ph.D. Dissertation, Uppsala University, Uppsala.
- , B. Bremer & M. Thulin. 2007. Paraphyly of Paederieae, recognition of Putorieae, and expansion of *Plocama* (Rubiaceae—Rubioideae). *Taxon* 56: 315–328.
- Bremekamp, C. E. B. 1954. Les sous-familles et les tribus des Rubiacées. Huitième congrès international de botanique, rapports et communications, Paris Sect. 2–6: 113–114.
- . 1966. Remarks on the positions the delimitations and subdivision of the Rubiaceae. *Acta Bot. Neerl.* 15: 1–33.
- Bremer, B. 1979. The genus *Neurocalyx* (Rubiaceae—Argostemmatae) in Ceylon. *Bot. Not.* 132: 399–407.

- . 1992. Phylogeny of the Rubiaceae (Chiococceae) based on molecular and morphological data—Useful approaches for classification and comparative ecology. *Ann. Missouri Bot. Gard.* 79: 380–387.
- . 1996. Phylogenetic studies within Rubiaceae and relationship to other families based on molecular data. *Opera Bot. Belg.* 7: 33–50.
- & O. Eriksson. 1992. Evolution of fruit characteristics and dispersal modes in the tropical family Rubiaceae. *Biol. J. Linn. Soc.* 47: 79–95.
- & R. K. Jansen. 1991. Comparative restriction site mapping of chloroplast DNA implies new phylogenetic relationships within Rubiaceae. *Amer. J. Bot.* 78: 198–213.
- & J. F. Manen. 2000. Phylogeny and classification of the subfamily Rubioideae (Rubiaceae). *Pl. Syst. Evol.* 225: 43–72.
- & L. Struwe. 1992. Phylogeny of the Rubiaceae and the Loganiaceae—Congruence or conflict between morphological and molecular data. *Amer. J. Bot.* 79: 1171–1184.
- & M. Thulin. 1998. Collapse of Isertieae, re-establishment of Mussaendeae, and a new genus of Sabiceae (Rubiaceae): Phylogenetic relationships based on *rbcL* data. *Pl. Syst. Evol.* 211: 71–92.
- , K. Andreasen & D. Olsson. 1995. Subfamilial and tribal relationships in the Rubiaceae based on *rbcL* sequence data. *Ann. Missouri Bot. Gard.* 82: 383–397.
- , R. K. Jansen, B. Oxelman, M. Backlund, H. Lantz & K. J. Kim. 1999. More characters or more taxa for a robust phylogeny—Case study from the coffee family (Rubiaceae). *Syst. Biol.* 48: 413–435.
- Bridson, D. M. & B. Verdcourt. 1988. Rubiaceae (Part 2). Pp. 415–747 in R. M. Polhill (editor), *Flora of Tropical East Africa*. A. A. Balkema, Rotterdam, The Netherlands, and Brookfield, United Kingdom.
- Church, S. A. 2003. Molecular phylogenetics of *Houstonia* (Rubiaceae): Descending aneuploidy and breeding system evolution in the radiation of the lineage across North America. *Molec. Phylogenet. Evol.* 27: 223–238.
- & D. R. Taylor. 2005. Speciation and hybridization among *Houstonia* (Rubiaceae) species: The influence of polyploidy on reticulate evolution. *Amer. J. Bot.* 92: 1372–1380.
- Cros, J., M. C. Combes, P. Trouslot, F. Anthony, S. Hamon, A. Charrier & P. Lashermes. 1998. Phylogenetic analysis of chloroplast DNA variation in *Coffea* L. *Molec. Phylogenet. Evol.* 9: 109–117.
- Davis, A. P., D. Bridson, C. Jarvis & R. Goverts. 2001. The typification and characterization of the genus *Psychotria* L. (Rubiaceae). *Bot. J. Linn. Soc.* 135: 35–42.
- , M. Chester, O. Maurin & M. F. Fay. 2007. Searching for the relatives of *Coffea* (Rubiaceae, Ixoroideae): The circumscription and phylogeny of Coffeae based on plastid sequence data and morphology. *Amer. J. Bot.* 94: 313–329.
- Delprete, P. G. 1996. Evaluation of the tribes Chiococceae, Condamineae, and Catesbaeeae (Rubiaceae) based on morphological characters. *Opera Bot. Belg.* 7: 165–192.
- & R. Cortés-B. 2004. A phylogenetic study of the tribe Sipaneeae (Rubiaceae, Ixoroideae), using *trnL-F* and ITS sequence data. *Taxon* 53: 347–356.
- , L. B. Smith & R. M. Klein. 2004. Rubiaceae. I parte, Volume I—Géneros de A–G: 1. *Alseis* até 19. *Galium*. Pp. 1–344 in A. Reis (editor), *Flora Ilustrada Catarinense*. Itajaí, Santa Catarina, Brazil.
- Dessein, S., L. Andersson, E. Robbrecht & E. Smets. 2001. *Hekistocarpa* (Rubiaceae): A member of an emended tribe Virectarieae. *Pl. Syst. Evol.* 229: 59–78.
- , ———, K. Geuten, E. Smets & E. Robbrecht. 2005. *Gomphocalyx* and *Phylohydrax* (Rubiaceae): Sister taxa excluded from Spermaceae s.s., featuring a remarkable case of convergent evolution. *Taxon* 54: 91–107.
- Ehrendorfer, F., J. F. Manen & A. Natali. 1994. cpDNA intergene sequences corroborate restriction site data for reconstruction Rubiaceae phylogeny. *Pl. Syst. Evol.* 190: 245–248.
- Eriksson, O. & B. Bremer. 1991. Fruit characteristics, life forms, and species richness in the plant family Rubiaceae. *Amer. Naturalist* 138: 751–761.
- Erwin, T. L. 1982. Tropical forests: Their richness in Coleoptera and other arthropod species. *Coleopterists Bull.* 36: 74–75.
- Fay, M. F., B. Bremer, G. T. Prance, M. van der Bank, D. Bridson & M. W. Chase. 2000. Plastid *rbcL* sequences show *Dialypetalanthus* to be a member of Rubiaceae. *Kew Bull.* 55: 853–864.
- Govaerts, R., L. Andersson, E. Robbrecht, D. Bridson, A. Davis, I. Schanzer & B. Sonke. 2006. World Checklist of Rubiaceae. The Board of Trustees of the Royal Botanic Gardens, Kew.
- Gustafsson, C. & C. Persson. 2002. Phylogenetic relationships among species of the neotropical genus *Randia* (Rubiaceae, Gardenieae) inferred from molecular and morphological data. *Taxon* 51: 661–674.
- Huysmans, S., G. El-Ghazaly & E. Smets. 1998. Orbicules in angiosperms. Morphology, function, distribution, and relation with tapetum types. *Bot. Rev.* 64: 240–272.
- , ——— & ———. 2000. Orbicules: Still a well hidden secret of the anther. Pp. 201–212 in B. Nordenstam, G. El-Ghazaly & M. Kassas (editors), *Plant Systematics for the 21st Century*. Wenner-Gren International Series, Vol. 77. Portland Press, London.
- , S. Dessein, E. Smets & E. Robbrecht. 2003. Pollen morphology of NW European representatives confirms monophyly of Rubieae (Rubiaceae). *Rev. Palaeobot. Palynol.* 127: 219–240.
- Jansen, S., F. Lens, S. Ntore, F. Piesschaert, E. Robbrecht & E. Smets. 2001. Contributions to the wood anatomy of the Rubioideae (Rubiaceae). *J. Pl. Res.* 114: 269–289.
- , E. Robbrecht, H. Beeckman & E. Smets. 2002. A survey of the systematic wood anatomy of the Rubiaceae. *Int. Assoc. Wood Anat. J.* 23: 1–67.
- , T. Watanabe, E. Smets & E. Robbrecht. 2003. A comparative study of metal levels in leaves of some Al-accumulating Rubiaceae. *Ann. Bot.* 91: 657–663.
- Kårehed, J. & B. Bremer. 2007. The systematics of Knoxiaceae (Rubiaceae)—Molecular data and their taxonomic consequences. *Taxon* 56: 1051–1076.
- Kiehn, M. 1995. Chromosome survey of the Rubiaceae. *Ann. Missouri Bot. Gard.* 82: 398–408.
- Kuhlmann, J. G. 1925. Contribuição para a conhecimento de algumas plantas novas, contendo também um trabalho de crítica e novas combinações. *Arch. Jard. Bot. Rio de Janeiro* 4: 347–365.
- Lantz, H. & B. Bremer. 2004. Phylogeny inferred from morphology and DNA data: Characterizing well-supported groups in Vanguerieae (Rubiaceae). *Bot. J. Linn. Soc.* 146: 257–283.
- & ———. 2005. Phylogeny of the complex Vanguerieae (Rubiaceae) genera *Fadogia*, *Rytigynia*, and *Vangueria* with close relatives and a new circumscription of *Vangueria*. *Pl. Syst. Evol.* 253: 159–183.

- , K. Andreasen & B. Bremer. 2002. Nuclear rDNA *ITS* sequence data used to construct the first phylogeny of Vanguerieae (Rubiaceae). *Pl. Syst. Evol.* 230: 173–187.
- Lashermes, P., M. C. Combes, P. Trouslot & A. Charrier. 1997. Phylogenetic relationships of coffee-tree species (*Coffea* L.) as inferred from *ITS* sequences of nuclear ribosomal DNA. *Theor. Appl. Genet.* 94: 947–955.
- Malcomber, S. T. 2002. Phylogeny of *Gaertnera* Lam. (Rubiaceae) based on multiple DNA markers: Evidence of a rapid radiation in a widespread, morphologically diverse genus. *Evolution* 56: 42–57.
- & A. P. Davis. 2005. Six new *Gaertnera* (Rubiaceae) species from Madagascar and phylogenetic analyses that support *Hymenocnemis* as a synonym of *Gaertnera*. In R. C. Keating, V. C. Hollowell & T. Croat (editors), *Festschrift for William G. D'Arcy: The Legacy of a Taxonomist*. *Monogr. Syst. Bot. Missouri Bot. Gard.* 104: 371–397.
- Manen, J. F. & A. Natali. 1996. The chloroplast *atpB-rbcL* spacer in Rubiaceae. *Opera Bot. Belg.* 7: 51–57.
- , ——— & F. Ehrendorfer. 1994. Phylogeny of Rubiaceae-Rubieae inferred from the sequence of cpDNA intergene region. *Pl. Syst. Evol.* 190: 195–211.
- Maurin, O., A. P. Davis, M. Chester, E. F. Mvungi, Y. J. Kakim & M. F. Fay. 2007. Towards a phylogeny of *Coffea* (Rubiaceae): Identifying well-supported lineages based on nuclear and plastid DNA sequences. *Ann. Bot.* 100: 1565–1583.
- McDowell, T. 1996. *Exostema* (Rubiaceae): Taxonomic history, nomenclature, position, and subgeneric classification. *Opera Bot. Belg.* 7: 277–295.
- & B. Bremer. 1998. Phylogeny, diversity, and distribution in *Exostema* (Rubiaceae): Implications of morphological and molecular analyses. *Pl. Syst. Evol.* 212: 215–246.
- , M. Volovsek & P. Manos. 2003. Biogeography of *Exostema* (Rubiaceae) in the Caribbean region in light of molecular phylogenetic analyses. *Syst. Bot.* 28: 431–441.
- Mongrand, S., A. Badoc, B. Patouille, C. Lacomblez, M. Chavent & J. J. Bessoule. 2005. Chemotaxonomy of the Rubiaceae family based on leaf fatty acid composition. *Phytochemistry* 66: 549–559.
- Motley, T. J., K. J. Wurdack & P. G. Delprete. 2005. Molecular systematics of the Catesbaeeae–Chiococceae complex (Rubiaceae): Flower and fruit evolution and biogeographic implications. *Amer. J. Bot.* 92: 316–329.
- Mouly, A., S. Razafimandimbison, F. Achille, T. Haeverman & B. Bremer. 2007. Phylogenetic placement of *Rhopalobrachium fragrans* (Rubiaceae): Evidence from molecular (*rps16* and *trnT-F*) and morphological data. *Syst. Bot.* 32: 872–882.
- Moynihan, J. & L. E. Watson. 2001. Phylogeography, generic allies, and nomenclature of Caribbean endemic genus *Neolaugeria* (Rubiaceae) based on internal transcribed spacer sequences. *Int. J. Pl. Sci.* 162: 393–401.
- Natali, A., J. F. Manen & F. Ehrendorfer. 1995. Phylogeny of the Rubiaceae–Rubioideae, in particular the tribe Rubieae: Evidence from a noncoding chloroplast DNA sequence. *Ann. Missouri Bot. Gard.* 82: 428–439.
- , ———, M. Kihn & F. Ehrendorfer. 1996. Tribal, generic, and specific relationships in the Rubioideae–Rubieae (Rubiaceae) based on sequence data of the cpDNA intergene region. *Opera Bot. Belg.* 7: 193–203.
- Negrón-Ortiz, V. & L. E. Watson. 2002. Molecular phylogeny and biogeography of *Erithalis* (Rubiaceae), an endemic of the Caribbean Basin. *Pl. Syst. Evol.* 234: 71–83.
- & ———. 2003. Hypotheses for the colonization of the Caribbean basin by two genera of the Rubiaceae: *Erithalis* and *Ernodea*. *Syst. Bot.* 28: 442–451.
- Nepokroeff, M., K. J. Sytsma & B. Bremer. 1999. Reorganization of the genus *Psychotria* and tribe Psychotrieae (Rubiaceae) inferred from *ITS* and *rbcL* sequence data. *Syst. Bot.* 24: 5–27.
- , ———, W. L. Wagner & E. A. Zimmer. 2003. Reconstructing ancestral patterns of colonization and dispersal in the Hawaiian understory tree genus *Psychotria* (Rubiaceae): A comparison of parsimony and likelihood approaches. *Syst. Biol.* 52: 820–838.
- Nie, Z. L., J. Wen, H. Sun & B. Bartholomew. 2005. Monophyly of *Kelloggia* Torrey ex Benth. (Rubiaceae) and evolution of its intercontinental disjunction between western North America and eastern Asia. *Amer. J. Bot.* 92: 642–652.
- Novotny, V., Y. Basset, S. E. Miller, G. D. Weiblen, B. Bremer, L. Cizek & P. Drozd. 2002. Low host specificity of herbivorous insects in a tropical forest. *Nature* 416: 841–844.
- Odegaard, F. 2000. How many species of arthropods? Erwin's estimate revised. *Biol. J. Linn. Soc.* 71: 583–597.
- Olmstead, R. G., B. Bremer, K. M. Scott & J. D. Palmer. 1993. A parsimony analysis of the Asteridae sensu lato based on *rbcL* sequences. *Ann. Missouri Bot. Gard.* 80: 700–722.
- Persson, C. 1996. Phylogeny of the Gardenieae (Rubiaceae). *Bot. J. Linn. Soc.* 121: 91–109.
- . 2000a. Phylogeny of Gardenieae (Rubiaceae) based on chloroplast DNA sequences from the *rps16* intron and *trnL(UAA)-F(GAA)* intergenic spacer. *Nord. J. Bot.* 20: 257–269.
- . 2000b. Phylogeny of the neotropical *Alibertia* group (Rubiaceae), with emphasis on the genus *Alibertia*, inferred from *ITS* and 5S ribosomal DNA sequences. *Amer. J. Bot.* 87: 1018–1028.
- Piesschaert, F. 2001. Carpology and Pollen Morphology of the Psychotrieae (Rubiaceae–Rubioideae). Ph.D. Dissertation, Katholieke Universiteit, Leuven.
- , E. Robbrecht & E. Smets. 1997. *Dialypetalanthus fuscescens* Kuhl. (Dialypetalanthaceae): The problematic taxonomic position of an Amazonian endemic. *Ann. Missouri Bot. Gard.* 84: 201–223.
- Puff, C. 1982. The delimitation of the tribe Anthospermeae and its affinities to the Paederieae (Rubiaceae). *Bot. J. Linn. Soc.* 84: 355–377.
- . 1986. *Phylohydrax* (Rubiaceae–Spermacoceae)—A new genus to accommodate the African and Madagascan “*Hydrophylax*” species. *Pl. Syst. Evol.* 154: 343–366.
- & U. Rohrhofer. 1993. The character states and taxonomic position of the monotypic mangrove genus *Scyphiphora* (Rubiaceae). *Opera Bot. Belg.* 6: 143–172.
- Razafimandimbison, S. G. & B. Bremer. 2001 [2002]. Tribal delimitation of Naucleaeae (Cinchonoideae, Rubiaceae): Inference from molecular and morphological data. *Syst. Geogr. Pl.* 71: 515–538.
- & ———. 2002. Phylogeny and classification of Naucleaeae s.l. (Rubiaceae) inferred from molecular (*ITS*, *rbcL*, and *trnT-F*) and morphological data. *Amer. J. Bot.* 89: 1027–1041.
- , E. A. Kellogg & B. Bremer. 2004. Recent origin and phylogenetic utility of divergent *ITS* putative pseudogenes: A case study from Naucleaeae (Rubiaceae). *Syst. Biol.* 53: 177–192.

- , J. Moog, H. Lantz, U. Maschwitz & B. Bremer. 2005. Re-assessment of monophyly, evolution of myrmecophytism, and rapid radiation in *Neonauclea* s.s. (Rubiaceae). *Molec. Phylogenet. Evol.* 34: 334–354.
- Rizzini, C. T. & P. Occhioni. 1949. Dialypetalanthaceae. *Lilloa* 17: 243–288.
- Robbrecht, E. 1988. Tropical woody Rubiaceae. *Opera Bot. Belg.* 1: 1–271.
- . 1993. Supplement to the 1988 outline of the classification of the Rubiaceae. Index to genera. *Opera Bot. Belg.* 6: 173–196.
- & C. Puff. 1986. A survey of the Gardenieae and related tribes (Rubiaceae). *Bot. Jarb. Syst.* 108: 63–137.
- & J.-F. Manen. 2006. The major evolutionary lineages of the coffee family (Rubiaceae, angiosperms). Combined analysis (nDNA and cpDNA) to infer the position of *Coptosapelta* and *Luculia*, and supertree construction based on *rbcL*, *rps16*, *trnL-trnF*, and *atpB-rbcL* data. A new classification in two subfamilies, Cinchonoideae and Rubioideae. *Syst. Geog. Pl.* 76: 85–146.
- Rova, J. H. E., P. G. Delprete, L. Andersson & V. A. Albert. 2002. A *trnL-F* cpDNA sequence study of the Condamineae–Rondeletieae–Sipaneeae complex with implications on the phylogeny of the Rubiaceae. *Amer. J. Bot.* 89: 145–159.
- Rydin, C., K. Kainulainen, S. G. Razafimandimbison, J. E. E. Smedmark & B. Bremer. 2009. Deep divergences in the coffee family and the systematic position of *Acranthera*. *Pl. Syst. Evol.* 278: 101–123.
- Smedmark, J. E. E., C. Rydin, S. G. Razafimandimbison, S. A. Khan, S. Liede-Schumann & B. Bremer. 2008. A phylogeny of Urophylleae (Rubiaceae) based on *rps16* intron data. *Taxon* 57: 24–32.
- Sohmer, S. H. & A. P. Davis. 2007. The genus *Psychotria* (Rubiaceae) in the Philippine Archipelago. *Sida, Botanical Miscellany* 27. Bot. Res. Inst. Texas, Fort Worth.
- Stork, N. E. 1993. How many species are there? *Biodivers. & Conservation* 2: 215–232.
- Thulin, M. & B. Bremer. 2004. Studies in the tribe Spermaceae (Rubiaceae–Rubioideae): The circumscriptions of *Amphiasma* and *Pentanopsis* and the affinities of *Phylohydrax*. *Pl. Syst. Evol.* 247: 233–239.
- Verdcourt, B. 1958. Remarks on the classification of the Rubiaceae. *Bull. Bot. État* 28: 209–281.
- Wichman, S. R., S. D. Wright, E. K. Cameron, D. J. Keeling & R. C. Gardner. 2002. Elevated genetic heterogeneity and Pleistocene climatic instability: Inferences from nrDNA in New Zealand *Coprosma* (Rubiaceae). *J. Biogeogr.* 29: 943–954.

REVISIÓN SINÓPTICA DE
GALIANTHE SUBGEN. *GALIANTHE*
(RUBIACEAE: SPERMACOCEAE),
CON UNA SECCIÓN NUEVA^{1,2}

Elsa L. Cabral³

RESUMEN

Galianthe subg. *Galianthe* Griseb. se caracteriza por el fruto de mericarpios dehiscentes, semillas rollizas o complanadas con bordes aliformes, inflorescencias generalmente amplias tirsoideas o pleiotirsoideas, flores heterostilas, hábito erecto generalmente con xilopodio y cromosomas $x = 8$. Está representada por 39 especies sudamericanas que se agrupan en dos secciones: sect. *Galianthe* (30 especies) y una nueva sect. *Laxae* E. L. Cabral (nueve especies y dos subespecies). Se acompañan claves para diferenciar las secciones y las especies de cada sección, con resumen sinóptico de las especies y mapas de distribución. Se designan neotipos para cuatro nombres: *Borreria angustifolia* Cham. & Schltdl. [– *G. angustifolia* (Cham. & Schltdl.) E. L. Cabral], *B. equisetoides* Cham. & Schltdl. [– *G. equisetoides* (Cham. & Schltdl.) E. L. Cabral], *B. thalictroides* K. Schum. [– *G. thalictroides* (K. Schum.) E. L. Cabral], *B. valerianoides* Cham. & Schltdl. [– *G. valerianoides* (Cham. & Schltdl.) E. L. Cabral]. Se designan lectotipos para cinco nombres: *B. centranthoides* f. *glabrior* Chodat & Hassl. [– *G. centranthoides* (Cham. & Schltdl.) E. L. Cabral], *B. ericoides* Cham. & Schltdl. [– *Galianthe peruviana* (Pers.) E. L. Cabral], *B. leiophylla* K. Schum. [– *G. fastigiata* Griseb.], *G. hassleriana* (Chodat) E. L. Cabral y *G. verbenoides* (Cham. & Schltdl.) Griseb.

ABSTRACT

The species of the genus *Galianthe* subg. *Galianthe* Griseb. are revised. The group comprises 39 species from South America and is characterized by its fruits of dehiscent mericarps, plump or complanate seeds with wing-like margins, usually wide, thyrsoid or pleiothyrsoid inflorescences, an erect habit generally with xylopodium, and a basic chromosome number $x = 8$. Two sections are recognized: section *Galianthe* (30 species) and the new section *Laxae* E. L. Cabral (nine species, including two subspecies). A key to the sections and their species are provided. The species published recently are not described in this work. Neotypes are here designated for four names: *Borreria angustifolia* Cham. & Schltdl. [– *G. angustifolia* (Cham. & Schltdl.) E. L. Cabral], *B. equisetoides* Cham. & Schltdl. [– *G. equisetoides* (Cham. & Schltdl.) E. L. Cabral], *B. thalictroides* K. Schum. [– *G. thalictroides* (K. Schum.) E. L. Cabral], and *B. valerianoides* Cham. & Schltdl. [– *G. valerianoides* (Cham. & Schltdl.) E. L. Cabral]. Lectotypes are designated here for five names: *B. centranthoides* f. *glabrior* Chodat & Hassl. [– *G. centranthoides* (Cham. & Schltdl.) E. L. Cabral], *B. ericoides* Cham. & Schltdl. [– *Galianthe peruviana* (Pers.) E. L. Cabral], *B. leiophylla* K. Schum. [– *G. fastigiata* Griseb.], *G. hassleriana* (Chodat) E. L. Cabral, and *G. verbenoides* (Cham. & Schltdl.) Griseb.

Key words: *Galianthe* subgenus *Galianthe*, Rubiaceae, Spermaceae.

Galianthe Griseb. es un género americano de la tribu Spermaceae (Robbrecht, 1988), representado por 49 especies de distribución tropical y subtropical. En la descripción original Grisebach lo define por: “fructus dicoccus, coccix aequaliter secedentibus apice et intus dehiscentibus. Semina oblonga, a dorso compressa. Flores in cymas iterato-tri-dichotomas v. apice breviter scorpioideas dispositi, alari ebracteato, lateralibus pedicellatis, foliis floralibus minutis”

(Grisebach, 1879). Además lo relaciona por las inflorescencias con el género *Emmeorrhiza* Pohl, por la dehiscencia de los frutos con *Borreria* G. Mey. y con *Galium* L. Haciendo alusión a este último género lo denomina *Galianthe*. Grisebach describió este género con dos especies nuevas, sobre material colectado por Lorentz en Argentina: *Galianthe fastigiata* Griseb., designado como tipo del género por Cabral (1991) y *G. clidemioides* Griseb., sinónimo

¹ Agradezco a los curadores de las distintas instituciones que han facilitado material en préstamo, cuyas siglas de los herbarios se citan a continuación: AS, B, B-W, BA, BAA, BAB, BACP, BAF, BHCB, BHMH, BM, BR, CEN, CEPEC, CORD, CTES, ESA, F, FCAB, FCQ, G, GB, G-DC, HAS, HB, HBR, IAC, IBGE, ICN, IPA, JPB, K, LIL, LP, LPB, MA, MBM, MCNS, MO, MVFA, MVM, NY, OUPR, P, PACA, PY, R, RB, SI, SP, SPF, TEX-LL, UB, UEC, UPCB, US, USZ. Agradezco a Nélida Bacigalupo la lectura crítica del manuscrito y estímulo permanente; a Carmen Cristóbal y Antonio Krapovickas por sus valiosas sugerencias; a Otto F. Ferber, Roberto Salas y Walter Medina por la colaboración en la edición de ilustraciones y mapas. Agradezco a Laura Simón por las ilustraciones.

² Los editores agradecen a Diana Gunter por su colaboración en la redacción de este manuscrito.

³ Instituto de Botánica del Nordeste (UNNE-CONICET), Facultad de Ciencias Exactas y Naturales y Agrimensura, UNNE, Casilla de Correo 209, 3400 Corrientes, Argentina. ecabral@agr.unne.edu.ar.

doi: 10.3417/2006193

de *G. centranthoides* (Cham. & Schltdl.) E. L. Cabral. En el mismo trabajo realizó una nueva combinación *G. verbenoides* (Cham. & Schltdl.) Griseb. [– *B. verbenoides* Cham. & Schltdl.], material erróneamente identificado por tratarse de *G. laxa* (Cham. & Schltdl.) E. L. Cabral (Cabral, 1991).

Schumann (1888) no acepta la propuesta de Grisebach de considerar a ese grupo de especies como un género independiente y lo vuelve a incluir en *Borreria* como sect. *Galianthe* (Griseb.) K. Schum., diferenciándolo por sus flores dimorfas en inflorescencias tirsoideas, de *Borreria* sect. *Borreria*, con flores isomorfas en inflorescencias capitadas terminales y/o axilares. Los estudios florísticos realizados con posterioridad siguieron en términos generales, el criterio de Schumann, sólo con algunos cambios menores.

Con el análisis de abundante material americano de *Borreria* s.l., se observaron marcadas diferencias morfológicas entre las especies de las dos secciones, motivo por el cual se buscaron nuevos elementos de juicio que pudieran aportar una correcta valoración de *Borreria* sect. *Galianthe*.

El estudio palinológico realizado por Pire y Cabral (1992) demostró la homogeneidad de los caracteres de los granos de polen (colporados, semitectados con retículo complejo) a diferencia de los de *Borreria* sect. *Borreria* en que los granos de polen son porados, colpados, colporados, tectado-perforado, foveolados (Cabral, 1985; Pire, 1997).

Con respecto a los datos citológicos, los primeros recuentos en especies de *Borreria* sect. *Borreria* mostraron un número básico, $x = 14$ (Kiehn, 1985, 1986, 1995). Posteriormente Daviña y Cabral (1991) obtuvieron el número básico, $x = 8$, en especies de *Borreria* sect. *Galianthe*, aportando los primeros recuentos cromosómicos en el género *Galianthe*.

Los siguientes caracteres diferenciales: inflorescencia tirsoidea con flores distilas, polen, semilla aladas o ápteras, cromosomas y distribución geográfica limitada esencialmente a América del sur, mientras que *Borreria* es pantropical, se consideraron suficientes para justificar la separación de las especies de *Borreria* sect. *Galianthe*, en otro género. De esta manera se rehabilitó el género *Galianthe* (Cabral, 1991) y se reconocieron en el mismo 20 especies de las cuales 18 son nuevas combinaciones, se incorporan nuevos sinónimos y se amplía el área de distribución geográfica de algunas especies. Del total de los taxones registrados por Schumann en *Borreria* sect. *Galianthe*, se excluyen sólo dos especies: *B. cymosa* (Spreng.) Cham. & Schltdl. y *B. monodon* K. Schum., por no reunir los caracteres que definen a *Galianthe*, las que fueron incorporadas en un género nuevo, *Scandentia* E. L. Cabral & Bacigalupo (Cabral

& Bacigalupo, 2001), caracterizado por hábito trepador, flores homostilas, semillas complanadas aladas y granos de polen zonocolporados con endoaberturas múltiples.

Además Cabral y Bacigalupo (1997) en el transcurso de la revisión de la tribu Spermaceae extrajeron unas especies de *Diodia* L. y *Borreria* sect. *Borreria* cuyos caracteres no se ajustaban a la definición de esos géneros y presentaban afinidad con *Galianthe*. Esta idea fue apoyada también por Pire (1997) porque sus granos de polen tienen exina de retículo doble, característica muy particular de *Galianthe*. Sin embargo estas especies tienen los mericarpos indehiscentes, entonces se incluyeron en *Galianthe* subg. *Ebelia* (Rchb.) E. L. Cabral & Bacigalupo (Cabral & Bacigalupo, 1997).

Los autores que han estudiado las especies reconocidas en este género, han utilizado diversos caracteres para definir las, como el tipo de inflorescencia (de Candolle, 1830), el dimorfismo floral (Schumann, 1888), dehiscencia de frutos, ramificación, estructura subterránea y semillas (Cabral, 2002), caracteres del polen (Pire & Cabral, 1992; Pire, 1997; Cabral, 2002), análisis embriológico (Galati, 1988, 1991) y recuentos cromosómicos (Kiehn, 1986, 1995; Daviña & Cabral, 1991; Cabral, 2002). Dessein (2003) en un estudio filogenético molecular confirma las sinapomorfías morfológicas, palinológicas y cromosómicas indicadas por Cabral y Bacigalupo y concluye que *Galianthe* merece la categoría genérica.

TRATAMIENTO SISTEMÁTICO

Galianthe Griseb., Symb. Fl. Argent. [Abh. Königl. Ges. Wiss. Göttingen] 24: 156. 1879. *Borreria* sect. *Galianthe* (Griseb.) K. Schum., Fl. Bras. (Martius) 6(6): 40–42. 1888. *Borreria* subg. *Galianthe* (Griseb.) Standl., Publ. Field Columbian Mus., Bot. Ser. 8(5): 392. 1931. TIPO: *Borreria leiophylla* K. Schum. [– *Galianthe fastigiata* Griseb.].

Distribución y hábitat. Constituido por 49 especies, sudamericanas, Argentina, Bolivia, Brasil, Paraguay, Uruguay y Perú, con excepción de un único taxón que vive naturalizada en México, Guatemala, Belice (*Galianthe brasiliensis* subsp. *angulata* (Benth.) E. L. Cabral & Bacigalupo). Habitan en campos rupestres, en campos bajos, en sabanas y laderas de cerros, en suelos lateríticos, arenosos o con afloramientos rocosos y en vegetación secundaria perturbada. Excepcionalmente son umbrófilas, en sotobosque de selvas y bosques (*G. hispidula* (A. Rich. ex DC.) E. L. Cabral & Bacigalupo, *G. brasiliensis* y *G. laxa* (Cham. & Schltdl.) E. L. Cabral).

CLAVE PARA DIFERENCIAR LOS SUBGÉNEROS DE *GALIANTHE*

- 1a. Fruto de mericarpos dehiscentes; semillas rollizas o complanadas, con margen aliforme; hábito erecto, con frecuencia xilopodio muy desarrollado, tallos nunca alados; cromosomas $x = 8$. América del Sur (1°S–35°S) subg. *Galianthe*
- 1b. Fruto de mericarpos indehiscentes; semillas rollizas con margen liso; hábito variado, postrado, erecto, trepador, sin xilopodio; tallos alados o no; cromosomas $x = 12, 14, 15$. Centro y Sudamérica (20°N–35°S) subg. *Ebelia*

Galianthe* subg. *Galianthe

Sufrútices erectos o apoyantes, con o sin xilopodio, glabros o pubescentes; tallos de tetragonos a subcilíndricos. Hojas sésiles o pseudopeciolas, opuestas y decusadas, con frecuencia pseudoverticiladas por la presencia de braquiblastos, persistentes o excepcionalmente caducas (*Galianthe equisetoides* (Cham. & Schltdl.) E. L. Cabral, *G. peruviana* (Pers.) E. L. Cabral, *G. reitzii* E. L. Cabral, *G. souzae* E. L. Cabral & Bacigalupo); estípulas persistentes, interpeciolares y unidas a la base de la hoja en forma de vaina, ésta a veces se prolonga; borde 1-multifimbriado, con glándulas apicales. Inflorescencias tirsoideas, a veces con inflorescencias parciales más o menos congestas. Flores dimorfas, actinomorfas, generalmente las flores brevistilas un poco más grandes que las longistilas; cáliz 4- raro 2-mero, con frecuencia con dientes menores en los senos, a veces también con coléteres; corola 4-mera, infundibuliforme, blanca, excepcionalmente rosada o lilacina, externamente glabra, pilosa o pubescente y en su interior con pelos moniliformes de distribución igual o diferente en flores longistilas y brevistilas; disco nectarífero entero o bipartido, tapizado por papilas estriadas; estambres fijos en la garganta de la corola o en filamentos de distinta longitud en flores longistilas o brevistilas, anteras dorsifijas, introrsas; gineceo 2-carpelar, 2-ocular, con 1 óvulo por lóculo, peltado, fijo al septo interocular; estilo filiforme, estigma bífido. Cápsula septicida de mericarpos dehiscentes, con cáliz persistente; semillas rollizas o complanadas, de margen con reborde o ala muy estrecha, estrofiolo persistente o caduco; exotesta con fovéolas superficiales o profundas, isodiámétricas o poligonales.

Granos de polen pequeños, medianos y grandes, prolato-esferoidal o subprolato, 6–7(8–10) colporos; exina semitectada-reticulada con retículo complejo (Pire & Cabral, 1992; Cabral, 2002); número cromosómico $x = 8$ (Daviña & Cabral, 1991).

Distribución geográfica y ecología. Las 39 especies viven en Sudamérica, al norte de Argentina y están ampliamente distribuidas en Bolivia, Brasil, Paraguay, Perú y Uruguay (1°–35°S); la mayor

concentración con 23 especies endémicas, en el planalto central y meridional de Brasil y en un sector del Paraguay oriental. Crecen en cerrados, campos rupestres y campos bajos, en suelos lateríticos, arenosos o con afloramientos rocosos (observ. pers. y referencias de etiquetas). Generalmente se hallan como plantas aisladas y sobreviven a incendios y suelos removidos por el xilopodio.

Las especies se reconocen por los caracteres incluidos en la clave y son presentadas por orden alfabético. En los apéndices 1 y 2 se proveen una lista de las especies y un índice de colecciones.

CLAVE PARA DIFERENCIAR LAS SECCIONES DEL SUBG. *GALIANTHE*

- 1a. Plantas con xilopodio; monocaules o pluricaules; tallos simples o con escasas ramas secundarias cortas; inflorescencia largamente pedunculada sólo en tallos primarios, o rara vez brevemente pedunculada en ramas secundarias I—sect. *Galianthe* (30 especies)
- 1b. Plantas sin xilopodio, pluricaules, con ramas secundarias desarrolladas; inflorescencia generalmente brevemente pedunculada en tallos primarios y en ramas secundarias II—sect. *Laxae* (9 especies)

I. *Galianthe* subg. *Galianthe* sect. *Galianthe*

Sufrútice con xilopodio desarrollado, con 1–20-tallos simples o si presentan ramas secundarias las inflorescencias se ubican sólo en los tallos primarios; inflorescencia pluriflora largamente pedunculada, raro pauciflora brevemente pedunculada; flores distilas, 4-meras, frutos capsulares; semillas frecuentemente aladas.

Comprende 30 especies que presentan su mayor concentración y mayor variabilidad en el planalto central y meridional de Brasil y en las serranías de Paraguay oriental, y gradualmente en menor cantidad de especies en Argentina, Bolivia, Perú y Uruguay, en campos, bajos, inundables o en campos altos hasta 3000 m. Figura 1 (A–F).

CLAVE PARA IDENTIFICAR LAS ESPECIES DE LA SECCIÓN *GALIANTHE*

- 1. Plantas monocaules o pluricaules; tallos simples o con ramas secundarias; inflorescencias largamente pedunculadas solo en tallos primarios 2
- 1. Plantas pluricaules, tallos con ramas secundarias; inflorescencias brevemente pedunculadas en tallos primarios y en ramas secundarias 27
- 2(1). Sufrútices con un tallo principal con ramas secundarias desarrolladas 3
- 2. Sufrútices con un tallo o varios tallos principales, tallos simples con escasos braquiblastos 4

- 3(2). Sufrútices con 1–2(–5) tallos de 0.4–1(–2.5) m alt. 9
3. Sufrútices con (5–)10–20 tallos de 0.1–0.5(–1) m alt. 23
- 4(2). Hojas lineares o linear-lanceoladas 5
4. Hojas elípticas, elíptico-lanceoladas, elíptico-oblongas o elíptico-ovadas 6
- 5(4). Hojas glabras, pubérulas o escabrosas, (8–)20–35 × (0.7–)3–5 mm; flores brevistilas; superficie interna de la corola solo con pelos en el tubo 7
5. Hojas pubescentes, 5–10 × 0.2–2 mm; flores brevistilas con pelos en la superficie interna del tubo corolino y en flores longistilas pelos en el tubo y en los pétalos 17. *G. linearifolia*
- 6(4). Hojas 8–25 × 0.7–2 mm, glabras; vaina estipular glabra o pubérula, con lacinias de 0.2–2.5 mm long.; hipanto y fruto glabros; superficie externa de la corola micropapilosa, papilas más densas en el dorso de los lóbulos 29. *G. thalictroides*
6. Hojas 20–35 × 3–4 mm, pubérulas; vaina estipular pubescente, con lacinias de 3–5 mm long.; hipanto y fruto pubescentes; superficie externa de la corola pubérula 22. *G. montesii*
- 7(5). Hojas de 6–11(–18) mm long., glabras, nervios secundarios inconspicuos 6. *G. elegans*
7. Hojas de 30–55(–70) mm long., escabriúsculas, levemente pubescentes o pubescentes, nervios secundarios visibles 8
- 8(7). Tallos casi glabros, con pelos ralos; vaina estipular brevemente prolongada por encima de la inserción del par de hojas correspondiente; hojas con nervios terciarios inconspicuos; hipanto papiloso o raro con pelos dispersos; fruto glabro 4–4.3 mm long. 4. *G. chodatiana*
8. Tallos pubescentes; vaina estipular truncada; hojas con nervios terciarios conspicuos; hipanto pubescente; fruto pubescente 4–6.5 mm long. 3. *G. centranthoides*
- 9(3). Plantas de 0.60–2.50 m alt.; en terrenos bajos inundables, pantanosos o en borde de arroyos, ríos, esteros o bañados 10
9. Plantas de 0.20–1.80 m alt.; viven en campos altos no inundables 13
- 10(9). Hojas oblongo-lanceoladas a lanceoladas con la base obtusa o truncada 11
10. Hojas filiformes, lineares, elípticas, lanceoladas u oblongo-lanceoladas, de base aguda o largamente atenuada 12
- 11(10). Tallos 0.60–0.80 m alt., subtetrágonos, glabros; hojas glabras con nerviación paralelodroma; vaina estipular 6–7 mm long., con una breve prolongación por encima de la inserción de las hojas, pubérula en el margen, con 5–6 lacinias filiformes 20. *G. macedoi*
11. Tallos 0.80–2.50 m alt., tetrágonos, escabrosos, ángulos con pelos retrorsos; hojas escábridas, plegado-nervosas, con 2–3 pares de nervios basales y 2–3 suprabasales, ligeramente paralelos; vaina estipular 3.5–5 mm long., pubescente, con 9–11 lacinias lineares o linear-subuladas 30. *G. valerianoides*
- 12(10). Hojas persistentes, lanceoladas u oblongo-lanceoladas, de base aguda a largamente atenuada, levemente pubescentes o escábridas, plegado-nervosas, con 4–5 pares de nervios; vaina estipular levemente pubescente o escábrida, con 7–12 lacinias de 5–25 mm long.; tallos subtetrágonos de 1–1.70 m alt.; semillas aladas 25. *G. pseudopeciolata*
12. Hojas caducas, lineares, filiformes o elípticas, de base aguda, glabras, planas con nervios secundarios inconspicuos o con 2–3 nervios secundarios; vaina estipular glabra, con 5–6 lacinias de 2–12 mm long.; tallos cilíndricos a subcilíndricos de 0.60–1.50 m alt., constrictos en los nudos; semillas redondeadas 7. *G. equisetoides*
- 13(9). Hojas de 0.5–5(–7) mm lat. 14
13. Hojas de (2–)5–25(–40) mm lat. 16
- 14(13). Nudos caulinares con pseudoverticilos hasta 15-foliolados; hojas glabras o pubérulas en ambas caras o solo en el envés, con 2–3(–4) pares de nervios secundarios 1. *G. angustifolia*
14. Nudos caulinares con pseudoverticilos 2–6-foliolados; hojas glabras, con nervios secundarios inconspicuos 15
- 15(14). Tallos de 0.40–1.5 m alt.; hojas 1–5(–7) mm lat.; vaina estipular 1–2.5 mm long., con lacinias de 2–10 mm long.; inflorescencia amplia, laxa, pauciflora, de 17–28 cm long.; corola 5–7.5 mm long. 5. *G. cyperoides*
15. Tallos de 0.40–0.60 m alt.; hojas de 0.5–1 mm lat.; vaina estipular 4.5–6.5 mm long., con lacinias de 5–15 mm long.; inflorescencia + comprimida, pluriflora, de 4–15 cm long.; corola 3–4.5 mm long. 18. *G. longifolia*
- 16(13). Hojas con nerviación secundaria inconspicua o el nervio primario conspicuo 17
16. Hojas con nerviación secundaria notoria 19
- 17(16). Nudos caulinares con pseudoverticilos hasta 10-foliolados 18
17. Nudos caulinares sin pseudoverticilos foliares 8. *G. fastigiata*
- 18(17). Nudos foliares 3–4-foliolados; vaina estipular truncada 5–10 mm long. con 3–5 lacinias soldadas formando un solo diente principal; corola rosada o lilacina 28. *G. souzae*
18. Nudos foliares 6–10-foliolados; vaina estipular prolongada, de margen irregular con notable lacinia central, triangular, acuminada y lacinias laterales más cortas; corola blanca 15. *G. latistipula*
- 19(16). Vaina estipular prolongada por encima de la inserción del par de hojas correspondiente 20
19. Vaina estipular no prolongada por encima de la inserción del par de hojas correspondiente 21
- 20(19). Nudos caulinares con pseudoverticilos; hojas (30)40–50 mm long., base redondeada a

- levemente cordada; corola de lóbulos y tubo + del mismo largo, con papilas largas en el dorso de los lóbulos 11. *G. guaranitica*
20. Nudos caulinares sin pseudoverticilos; hojas 55–90 mm long., con base subatenuada; corola de lóbulos más largos que el tubo, externamente micropapilada, con papilas cortas en el ápice de los lóbulos 21. *G. matogrossiana*
- 21(19). Tallos de 0.60–1.80 m alt., enteramente pubérulos a diversifaciales; hojas (0.5–)2–4 cm lat., pubérulas a pubescentes . . . 10. *G. grandifolia*
21. Tallos de 0.30–0.60 m alt., glabros a pubérulos; hojas de 0.5–1.7 cm lat., glabras a pubérulas 22
- 22(21). Hojas pubérulas, secas discoloras, de haz ferrugínea; estípulas con 7–10 lacinias pubérulas a pubescentes; hipanto papiloso 16. *G. liliifolia*
22. Hojas glabras, concoloras; estípulas con 3–5 lacinias glabras; hipanto pubescente 12. *G. hassleriana*
- 23(3). Sufrútices erectos, decumbentes o apoyantes, de 3–5-caule; vaina estipular de borde irregular, terminado en 3–5 lóbulos, triangular-lanceolados; corola rosado-lilacina o blanquecina 9. *G. gertii*
23. Sufrútices erectos, de 5–20-caule; vaina estipular de borde regular, terminadas en 3–6 lacinias filiformes; corola blanca 24
- 24(23). Hojas filiformes, lineares o lanceoladas de (0.3–)0.5–0.9(–3) mm lat. con nervios secundarios inconspicuos 24. *G. peruviana*
24. Hojas ovadas, elípticas o lanceoladas de 3–18 mm lat., con 3–6 pares de nervios secundarios conspicuos 25
- 25(24). Hipanto micropapilado, cáliz con segmentos linear-subulados o triangulares, reflexos en el fruto; hojas secas con nervadura obscura contrastante con el color de la lámina del envés 19. *G. longisepala*
25. Hipanto pubescente, cáliz con segmentos triangulares, no reflexos en el fruto; hojas secas, con nervadura del mismo color de la lámina del envés 26
- 26(25). Plantas muy ramificadas hasta con 20 ejes principales, de 12–30 cm alt.; hojas pubescentes en ambas caras; vaina estipular 2–3 mm long.; corola de 2–3 mm long.; cápsula de 3–3.5 mm long., pubescente 26. *G. ramosa*
26. Plantas ramificadas hasta con 6 ejes principales, de (20–)50–80 cm alt.; hojas con indumento variado entre la haz y el envés, pubérulas o glabras en la haz y levemente pubescente o pubescentes en el envés; vaina estipular 4–5 mm long.; corola de 3.2–4 mm long.; cápsula de 3.5–5(–5.5) mm long., levemente pubescente 14. *G. lanceifolia*
- 27(1). Hojas con nervios secundarios inconspicuos . . . 28
27. Hojas con 3–5 pares de nervios secundarios conspicuos 29
- 28(27). Vaina estipular pubérula con una lacinia central subulada hasta de 1.5–1.8 mm long. y dos apéndices laterales escasamente desarrollados de 0.5–0.7 mm long.; corola 5–6 mm long. 27. *G. reitzii*
28. Vaina estipular levemente pubescente, pubérula o pubescente, con 3–6 lacinias subiguales, filiformes de 1–3.2 mm long.; corola de 3–4 mm long. 24. *G. peruviana*
- 29(27). Hojas plegado-nervosas, pubescentes; vaina estipular pubescente, con 5–7 lacinias; interior de la corola brevistila con pelos moniliformes sólo en el tubo . . . 2. *G. canindeyuensis*
29. Hojas planas, glabras o pubérulas; vaina estipular pubérula, con 3–5 lacinias; interior de la corola brevistila con pelos moniliformes en el tubo y en los lóbulos 30
- 30(29). Planta de 0.80–1 m alt.; hojas con 3 pares de nervios secundarios; cápsula 4–6 mm long., turbinada, pubérula o glabra; semilla alada con el dorso convexo y cara ventral + plana, con estrofiolo persistente 13. *G. kempffiana*
30. Planta de 20–25(–40) cm alt.; hojas con 4–5 pares de nervios secundarios; cápsula 2.5–3 mm long., subglobosa, pilosa; semilla lisa, subcilíndrica con estrofiolo caduco 23. *G. parvula*

1. *Galianthe angustifolia* (Cham. & Schltld.)
E. L. Cabral, Bol. Soc. Argent. Bot. 27(3–4): 239. 1991 [1992]. Basónimo: *Borreria angustifolia* Cham. & Schltld., Linnaea 3: 330. 1828. TIPO: Brasil. Minas Gerais: Minas Gerais, Poços de Caldas, Cristo Redentor, 14 ene. 1980, A. Krapovickas & C. Cristóbal 35308 (neotipo, designado aquí, SP!; isotipo, CTES!). Figura 2.

Sufrútice con xilopodio, tallos erectos, de 20–70 cm alt., simples o con escasas ramificaciones secundarias, glabros o pubérulos. Hojas 15–55 × 1–5 mm, filiformes, lineares o linear-lanceoladas, ápice acuminado, base atenuada, margen recurvo, glabras, o pubérulas en ambas caras o sólo en el envés, 2 o 3 (raro 4) pares de nervios secundarios, surcados en la haz y prominentes en el envés; vaina estipular 3–4 mm, pubérula o pubescente, 5 ó 7 lacinias, 1.5–7 mm. Inflorescencia terminal. Hipanto 1.2–1.5 mm, glabro, cáliz con lóbulos de 0.7–1.2 mm, triangular-subulados, glabros; corola 3–4 mm, superficie externa papilosa e interna con pelos densos, delgados en el tubo y gruesos en los lóbulos; disco entero. Flor brevistila: corola, lóbulos iguales o más cortos que el tubo; estambres exertos, anteras 1 mm, filamentos 0.5–0.7 mm; estilo 2–3 mm. Flor longistila: corola con lóbulos tan largos como el tubo; anteras subsésiles, 0.7–1 mm; estilo 3.7–4.2 mm. Cápsula 3–4 mm, subcilíndrica, glabra;



Figura 1. Distribución de especies de la sección *Galianthe*. —A. Distribución de *G. angustifolia*, *G. canindeyuensis*, *G. centranthoides*, *G. chodatiana*, *G. cyperoides*. —B. Distribución de *G. elegans*, *G. equisetoides*, *G. fastigiata*, *G. gertii*, *G. grandifolia*. —C. Distribución de *G. guaranítica*, *G. hassleriana*, *G. kempffiana*, *G. lanceifolia*, *G. latistipula*. —D. Distribución de *G. liliifolia*, *G. linearifolia*, *G. longifolia*, *G. longisepala*, *G. macedoi*. —E. Distribución de *G. matogrossiana*, *G. montesii*, *G. parvula*, *G. peruviana*, *G. pseudopeciolata*. —F. Distribución de *G. ramosa*, *G. reitzii*, *G. souzae*, *G. thalictroides*, *G. valerianoides*.

semillas 2.5–2.7 mm, complanadas dorsiventralmente, aladas, ala más desarrollada en los extremos.

Distribución, hábitat y fenología. Brasil, en el planalto central (Goiás, Mato Grosso, Minas Gerais, Rondonia y São Paulo); frecuente en campos cerrados,

1000–1600 m, con suelos rocosos, sujetos a quemazones periódicas; florece de octubre a enero, fructifica de febrero a junio.

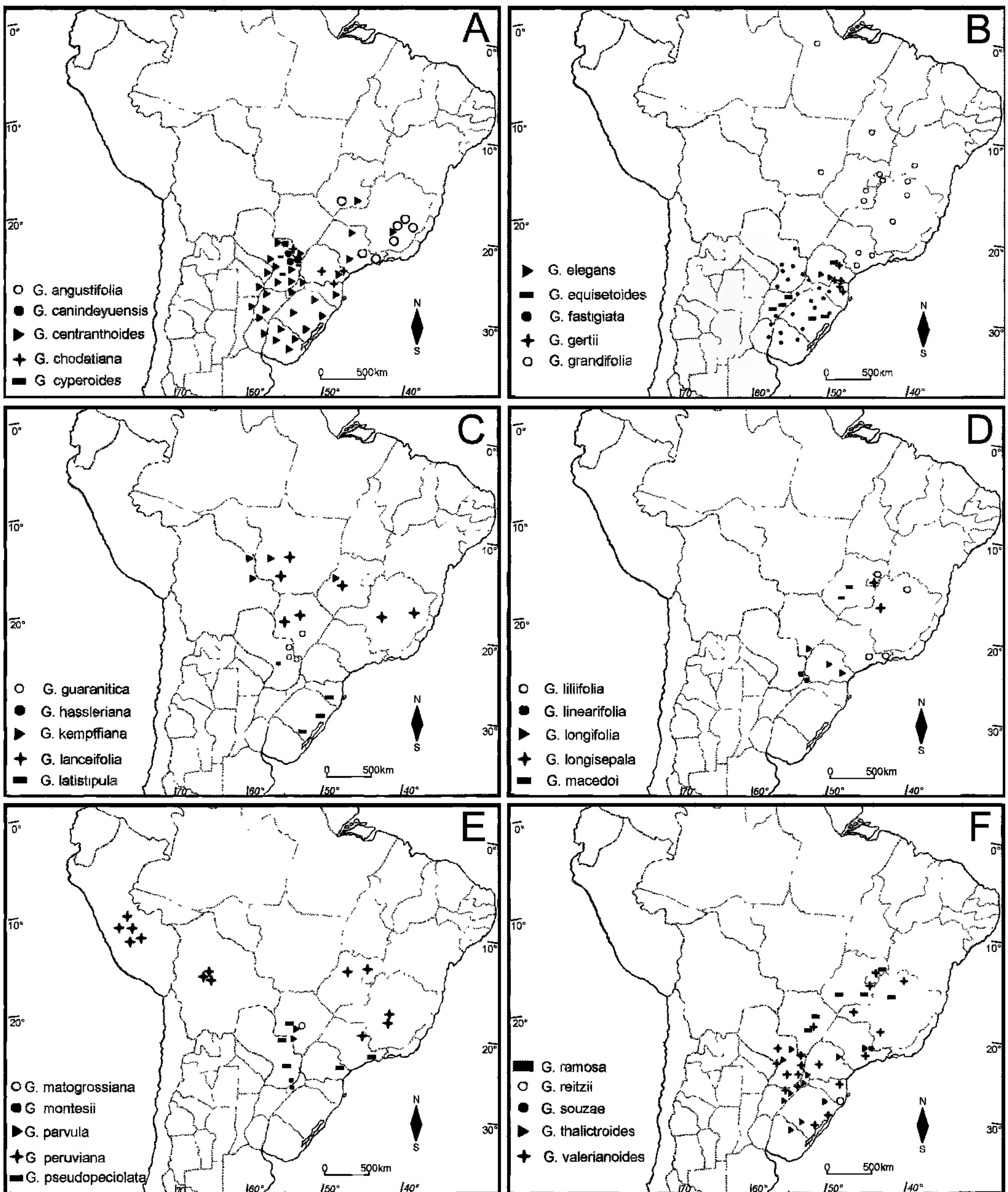
Discusión. En el protólogo del basónimo *Borreria angustifolia* es mencionado un solo ejemplar, el que

fue destruido en el herbario B, razón por la cual se elige el neotipo de Brasil, Minas Gerais, A. Krapovickas & C. Cristóbal 35308.

Material representativo estudiado. BRASIL. **Goiás:** Serra Dourada, 22 ene. 1967, A. Duarte 10235 (RB). **Mato Grosso:** Km 165 da Rodovia, Cuiabá-Santarem, 20 jun. 1979, M. Silva et al. 5029 (MG). **São Paulo:** São Bento do Sapucaí, 13 abr. 1995, J. Tamashiro et al. 873 (SP).

2. *Galianthe canindeyuensis* E. L. Cabral, Bonplandia (Corrientes) 7: 8. 1993. TIPO: Paraguay. Canindeyú: Colonia Fortuna, 8 km de Curuguaty, 6 mayo 1974, P. Arenas 662 (holotipo, CTES!; isotipos, BACP!, SI!).

Distribución, hábitat y fenología. Paraguay (Amambay, Caaguazú, Canindeyú y San Pedro), en campos cerrados, arenosos, rocosos, 200–400 m; florece de diciembre a febrero, fructifica de marzo a junio.

Observaciones. Es una especie de fácil reconocimiento, por ser totalmente pubescente, muy ramificada, de hojas plegado-nervosas, inflorescencia más o menos comprimida. Es afín a *Galianthe centranthoides*, porque ambas especies son ramificadas, con hojas plegado-nervosas, pubescentes, en *G. canindeyuensis* las semillas son subcilíndricas, ápteras (vs. semillas complanadas, aladas, en *G. centranthoides*) y las inflorescencias más o menos comprimidas (vs. inflorescencias laxas).

Chodat y Hassler (1904) citan un único ejemplar Hassler 5839 para Paraguay, como *Borreria eupatorioides* Cham. & Schltldl. [– *Galianthe eupatorioides* (Cham. & Schltldl.) E. L. Cabral], pero ese material corresponde a *G. canindeyuensis*.

Material representativo estudiado. PARAGUAY. **Amambay:** 30 km E de Pedro J. Caballero, feb. 1980, S. Tadashi 275 (MO). **Caaguazú:** In viciniis Caaguazú, 1905, E. Hassler 9156 (G, NY). **San Pedro:** Yaguareté forest, 23°48'38"S, 56°07'00"W, 20 jun. 1995, E. Zardini et al. 42813 (CTES, MO, PY).

3. *Galianthe centranthoides* (Cham. & Schltldl.) E. L. Cabral, Bol. Soc. Argent. Bot. 27(3–4): 240. 1991 [1992]. Basónimo: *Borreria centranthoides* Cham. & Schltldl., Linnaea 3: 327. 1828. TIPO: Brasil. Brasilia meridionali pluries lectam misit, 1829, Sellow s.n. (holotipo, HB no visto; isotipos, G!, LE!).

Borreria centranthoides var. *latifolia* Cham. & Schltldl., Linnaea 3: 329. 1828. TIPO: Brasil. Sellow s.n. (holotipo, HB no visto; isotipo, LE!).

Borreria centranthoides var. *angustifolia* Cham. & Schltldl., Linnaea 3: 330. 1828. TIPO: Brasil. Sellow 4993 (holotipo, HB no visto; isotipo, LE!).

Borreria pohliana DC., Prodr. 4: 550. 1830. TIPO: Brasil. In Brasilia, 1828, Pohl s.n. (holotipo, HB no visto; isotipo, G-DC!).

Galianthe clidemioides Griseb., Symb. Fl. Argent. 24: 157. 1879. *Spermacoce clidemioides* (Griseb.) Niederl., Bol. Mens. Mus. Prod. Argent. 3: 306. 1890. TIPO: Argentina. Entre Ríos: Palmar Grande, s.d., P. Lorentz 804 (holotipo, HB no visto; isotipos, CORD!, K!).

Borreria centranthoides f. *glabrior* Chodat & Hassl., Bull. Herb. Boissier, sér. 2, 4: 188. 1904. TIPO: Paraguay. In campo prope San Estanislao, ago., E. Hassler 4249 (lectotipo, designado aquí, G!; isotipos, K!, MO!, P!).

Borreria centranthoides f. *latifolia* Chodat & Hassl., Bull. Herb. Boissier, sér. 2, 4: 188. 1904. TIPO: Paraguay. Inter rupes in collibus prope Paraguay, dic., E. Hassler 6516 (holotipo, G!; isotipos, NY!, P!).

Borreria centranthoides f. *pubescens* Chodat & Hassl., Bull. Herb. Boissier, sér. 2, 4: 188. 1904. TIPO: Paraguay. In campos glareosis prope Valenzuela, ene., E. Hassler 6976 (holotipo, G!; isotipos, K!, MO!, P!).

Borreria centranthoides f. *angustifolia* Chodat & Hassl., Bull. Herb. Boissier, sér. 2, 4: 188. 1904. TIPO: Paraguay. In uliginosis Cordillera de Altos, oct., E. Hassler 3314 (holotipo, G!; isotipo, K!).

Observaciones. Se caracteriza por ser un sufrútice pubescente, con xilopodio voluminoso hasta de 1 m long., 1 a 4 tallos primarios con ramas secundarias desarrolladas; hojas elípticas, pubescentes, plegado-nervosas; inflorescencias terminales sólo en los tallos primarios, largamente pedunculadas, ejes y brácteas pubescentes; corola externamente pubescente e internamente con pelos densos, en el tubo y en los lóbulos; cápsula pubescente y semillas aladas, comprimidas dorsiventralmente, estrofiolo caduco, plano, adosado a la cara ventral.

Galianthe centranthoides presenta variabilidad en la morfología, tamaño de las hojas y densidad de la pubescencia de toda la planta, que confundió su verdadera identidad, razón por la cual se incluyen varios sinónimos y numerosos nombres subespecíficos.

En medicina popular en el nordeste de Argentina, el cocimiento de las raíces, es usada como abortivo, diurético, purgativo, para la ictericia, el asma (Martínez Crovetto, 1981). En el sur de Brasil es conocida como remedio popular para los males de hígado y vías urinarias, contiene resina odorífica, tanino catéquico, saponina, óleo volátil aromático, fitosterina (Lucas & Machado, 1944).

Nombres vulgares. “Guaycurú”, “raíz gaycurú”, “guaycurú rapó” “raíz charrúa”, “sabugueirinho do campo”: de la Peña y Pensiero (2004), y extraído de las observaciones de etiquetas.

Distribución, hábitat y fenología. Nordeste de la Argentina (Corrientes, Chaco, Entre Ríos, Formosa, Misiones, Santa Fe), sur de Brasil (Goiás, Minas Gerais, Paraná, Rio Grande do Sul, Santa Catarina, São Paulo), Paraguay oriental (Alto Paraná, Amambay, Caaguazú, Canindeyú, Central, Caazapá, Concepción, Guairá, Itapúa, Misiones, San Pedro, Paraguari) y Uruguay (Artigas, Colonia, Florida, Lavalleja, Mal-

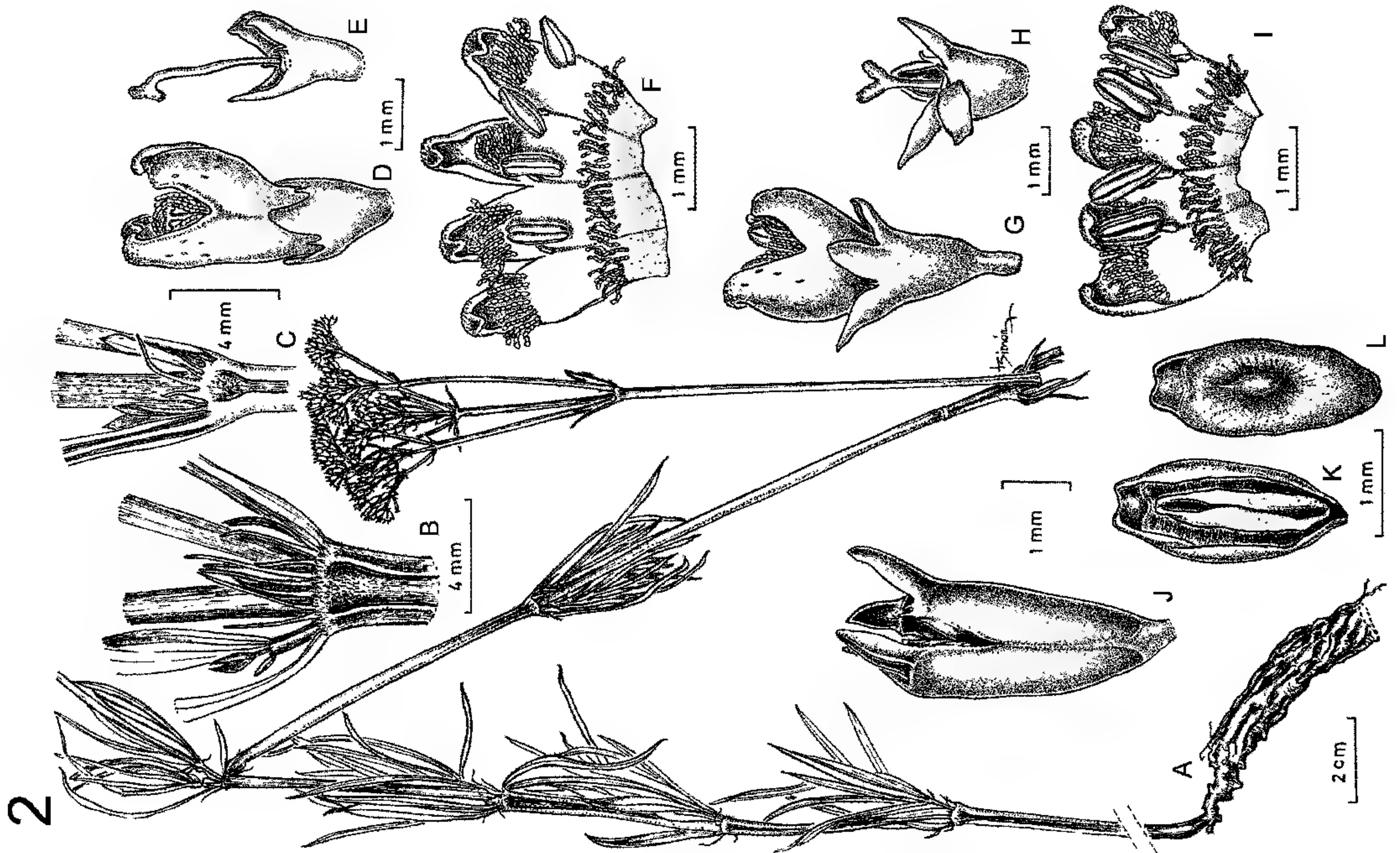
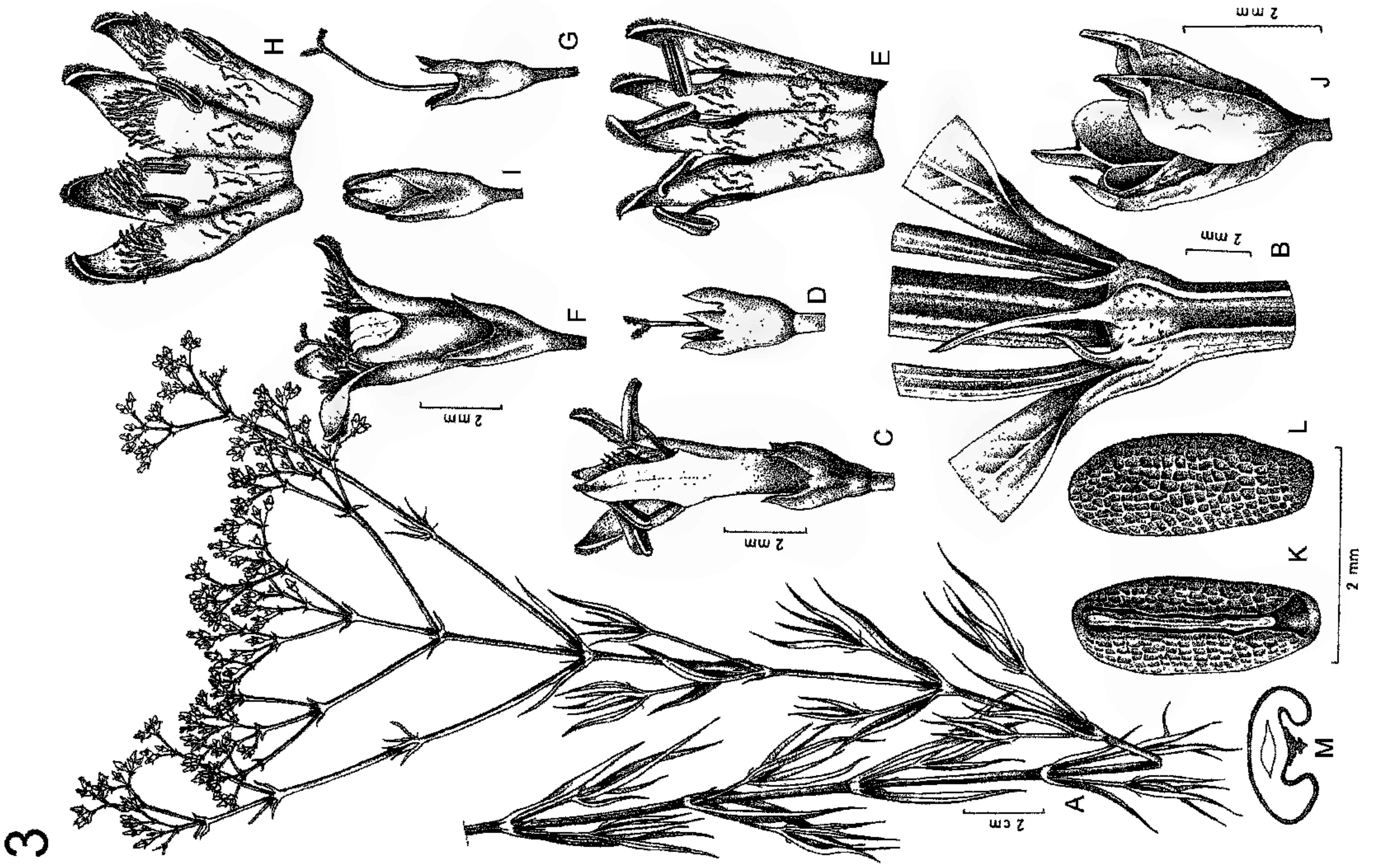

donado, Rivera), en lugares modificados, entre la vegetación secundaria, en la orilla de los caminos y preferentemente en campos de suelos arenosos, sujetos a quemazones periódicas, 50–1000 m; florece de septiembre a diciembre, fructifica de enero a mayo.

Material representativo estudiado: ARGENTINA. **Corrientes:** Santa Catalina, Ayo. Riachuelo, 2 dic. 2000, *E. Cabral 667* (CTES). **Entre Ríos:** Concepción del Uruguay, 27 nov. 1878, *P. Lorentz 1729* (BAF). **Formosa:** mar. 1918, *P. Jörgensen 2634* (MVM). **Misiones:** Candelaria, Bonpland, Ayo. Mártires Chico, 16 ene. 1976, *A. Krapovickas et al. 28791* (CTES). **Santa Fe:** 1904, *A. Venturi 133* (BAB). BRASIL. **Goiás:** Chapada dos Veadeiros, 20 feb. 1969, *H. Irwin et al. 24763* (RB). **Minas Gerais:** Turvo, 24 abr. 1926, *F. C. Hoehne et al. 17474* (SP). **Paraná:** Mun. Porto Amazona Fda. S. Luiz, 22 dic. 1963, *G. Hatschbach 10893* (B, MBM). **Santa Catarina:** Araranguá, 7 dic. 1944, *R. Reitz 869 C* (CTES, RB). **São Paulo:** 1821, *A. Saint-Hilaire 1472* (P). **Rio Grande do Sul:** Rio Guaribova, 20 ene. 1909, *P. Dusén 7534* (MO). PARAGUAY. **Alto Paraguay:** Primavera, 8 ene. 1961, *A. Woolston 1241* (NY, US). **Amambay:** Sierra de Amambay, dic. 1907, *T. Rojas 9820* (F). **Caaguazú:** Prope Caaguazú, feb. 1905, *E. Hassler 9213* (G, NY, P). **Caazapá:** 20 km E de San Miguel, desvío a 3 de Mayo y Capitindý, 11 nov. 1987, *M. M. Arbo et al. 2875* (CTES). **Cordillera:** Piribebuy, 22 jun. 1951, *T. Rojas 13951* (BAF, CTES). **Guairá:** In regione collium, Cordillera de Villarrica, ene. 1905, *E. Hassler 8850* (P). **Misiones:** 12 km W de San Ignacio, camino a Pilar, 15 nov. 1978, *L. Bernardi 18648* (MO). **Paraguarí:** Piraretá, 20 nov. 1980, *E. Lurvey 256* (CTES, MO). **San Pedro:** 16 oct. 1955, *G. Woolston 599* (NY, SP). URUGUAY. **Artigas:** Tomás Comensoro, 15 ene. 1971, *E. Marchesi 10209* (MVFA). **Colonia:** Punta Gorda, 24 ene. 1964, *O. Del Puerto et al. 3197* (MVFA). **Florida:** Ayo. Mansavillagra, nov. 1946, *B. Rosengurt et al. 5800* (MO, SP). **Lavalleja:** Polanco, 28 oct. 1968, *O. Del Puerto et al. 7607* (MVFA). **Maldonado:** Cuchilla de la Ballena, 14 nov. 1899, *C. Osten 3958* (MVM).

4. *Galianthe chodatiana* (Standl.) E. L. Cabral, Bol. Soc. Argent. Bot. 27(3–4): 242. 1991 [1992]. Basónimo: *Borreria chodatiana* Standl., Publ. Field Columbian Mus., Bot. Ser. 8: 393. 1931. TIPO: Paraguay. Sierra de Maracayú, *E. Hassler 5165* (holotipo, G!; isotipos, BM!, F!, G!, K!, P!). Figura 4.

Borreria thalictroides var. *latifolia* Chodat & Hassl., Bull. Herb. Boissier, sér. 2, 4: 189. 1904. TIPO: Paraguay. In campo Ipe hu (Sierra de Maracayú), oct., *E. Hassler 5168* (holotipo, G!; isotipos, F!, K!, NY!).

Sufrútice con xilopodio, de 0.30–0.60(–1) m alt., 1- ó 5-caule, tallos subtetrágonos, glabros, raro pelos dispersos. Hojas 30–45 × 5–15 mm, elípticas, elíptico-oblongas, ápice agudo o atenuado, base largamente aguda en pseudopeciolo, discoloras, más oscuras en la haz, escabriúsculas, pubescentes o con pelos dispersos sobre los nervios del envés, con 3(4) pares de nervios secundarios, notables en el envés; vaina estipular con una breve prolongación por encima de la separación del par de hojas, de 3–5 mm, pilosa o pubescente, con 6 ó 7 laciniás, 1.5–6 (–10) mm, glabras. Inflorescencias tirsoideas terminales, sólo en los tallos primarios, largamente pedunculadas, 20–35 cm. Hipanto 2–2.3 mm, turbinado, papiloso, con escasos pelos dispersos, lóbulos del cáliz 1–1.5 mm, triangular-subulados, glabros; corola 4.5–5 mm, longitud de lóbulos ± igual que el tubo; disco bipartido. Flor brevistila: superficie interna de la corola con pelos en la base de los lóbulos y en el tercio inferior del tubo; anteras 1.2–1.5 mm, filamentos 1.5–2.3 mm; estilo 2.3–2.5 mm. Flor longistila: superficie interna de la corola con pelos gruesos en los lóbulos y en anillo denso de pelos más finos en la mitad del tubo, anteras subsésiles, 1.3–1.5 mm; estilo 3–5 mm. Cápsula 2.5–4.3 mm, glabra; semillas 3–3.5 mm, complanadas, de borde alado, manifiesto en los polos.

Distribución, hábitat y fenología. En Brasil, Paraná y localidades vecinas de Santa Catarina; frecuente en campos, secos o levemente húmedos, de 700–900 m. De Paraguay se conoce hasta el momento, sólo las colecciones tipos de Hassler, que proceden del depto. Canindeyú; florece desde octubre, fructifica en enero y febrero.

Material representativo estudiado. BRASIL. **Paraná:** Mun. Curitiba, Instituto de Biología, 13 ene. 1966, *J. C. Lindeman et al. 309* (CTES, RB). **Santa Catarina:** Campo Ere, 22 feb. 1964, *A. Castellanos 24690* (RB).

5. *Galianthe cyperoides* (Chodat & Hassl.) E. L. Cabral, Bol. Soc. Argent. Bot. 27(3–4): 241. 1991 [1992]. Basónimo: *Borreria cyperoides* Chodat & Hassl., Bull. Herb. Boissier, sér. 2, 4: 187. 1904. TIPO: Paraguay. In campo Apepu (Tapiraguay), ago., *E. Hassler 4338* (lectotipo, designado por

Figura 2. *Galianthe angustifolia*. —A. Planta. —B–C. Vaina estipular con laciniás. D–F. Flor longistila. —D. Flor. —E. Hipanto, cáliz, estilo y estigma. —F. Interior de la corola desplegada. G–I. Flor brevistila. —G. Flor. —H. Hipanto, cáliz, estilo y estigma. —I. Interior de la corola desplegada. —J. Fruto. K–L. Semilla. —K. Cara ventral. —L. Cara dorsal. (A–F, J–L, *Krapovickas 35308*; G–I, *Hauff 20*.)

Figura 3. *Galianthe cyperoides*. —A. Planta. —B. Vaina estipular con laciniás. C–E. Flor brevistila. —C. Flor. —D. Hipanto, cáliz, estilo y estigma. —E. Interior de la corola desplegada. F–I. Flor longistila. —F. Flor. —G. Hipanto, cáliz, estilo y estigma. —H. Interior de la corola desplegada. —I. Alabastro. —J. Fruto. K–M. Semilla. —K. Cara ventral. —L. Cara dorsal. —M. Corte transversal. (A–B, F–I, *Hassler 9028*; C–E, *Hassler 4338*; J–M, *Schinini 33309*.)

Cabral [1991: 241], G!; isotipos, K!, P!).
Figura 3.

Borreria leiophylla var. *expansa* Chodat & Hassl., Bull. Herb. Boissier, sér. 2, 4: 187. 1904. TIPO: Paraguay. In campo prope, Igatimi, oct., *E. Hassler 4829* (holotipo, G!; isotipos, G!, K!, MO!, NY!, P!, US!).

Sufrútice con xilopodio de 0.40–1.50 m alt., tallos simples o escasamente ramificados, tetragonos, glabros, entrenudos 1–7.5 cm, pseudoverticiladas. Hojas 15–70 × 1–5(–7) mm, lineares o linear-lanceoladas, glabras, con nervios secundarios inconspicuos; vaina estipular 1–2.5 mm, glabra o pubérula, con 3 ó 5 laciniás de 2–10 mm. Inflorescencia tirsoide, amplia, laxa, pauciflora, 17–28 cm. Flores con hipanto 1–1.5 mm, turbinado, glabro; cáliz con lóbulos triangular-acuminados, 1–1.5 mm; corola externamente con papilas notables, densas, en el ápice dorsal de los lóbulos, lóbulos iguales o más cortos que el tubo; disco entero, papiloso. Flor brevistila: corola 6–7.5 mm, superficie interna con pelos moniliformes, cortos, en la mitad del tubo y pelos dispersos en la mitad inferior de los lóbulos; anteras 1–1.2 mm, filamentos 1.5–2.3 mm; estilo 2–3.7 mm. Flor longistila: corola 5–6.2 mm, superficie interna con anillo de pelos moniliformes, delgados y cortos en el tubo y arcos de pelos moniliformes en los lóbulos; anteras 1–1.2 mm, filamentos ca. 0.7 mm; estilo 4–6 mm. Cápsula 3–3.5 mm, subelipsoide, glabra; semillas 2.5–2.7 mm, con foveolas conspicuas, de dorso convexo y cara ventral plana, con surco alrededor del estrofiolo persistente.

Distribución, hábitat y fenología. Paraguay (Caaguazú, Canindeyú, Guairá, San Pedro), en campos altos, cerrados, 200–400 m, con frecuencia asociada a palmares de *Butia paraguayensis* (Barb. Rodr.) L. H. Bailey y *B. yatay* (Mart.) Becc.; florece y fructifica de septiembre a mayo.

Material representativo estudiado. PARAGUAY. **Caaguazú:** 2 km N of Arroyo Guaranunga, 25°22'S, 55°55'W, 5 ene. 1991, *E. Zardini et al. 25670* (AS, CTES, MO). **Canindeyú:** 46 km S de Katueté, 3 km N del río Itambery, ruta Pto. Stroessner–Saltos del Guairá, 18 dic. 1982, *A. Schinini 23212* (CTES). **Guairá:** Cerro de Villarrica, Cerro Pelado, ene. 1905, *E. Hassler 8784A* p.p. (G). **San Pedro:** betw. Santa Rosa & Santa Barbara, 23°50'32"S, 56°23'39"W, *E. Zardini et al. 45560* (AS, CTES, MO).

6. *Galianthe elegans* E. L. Cabral, Bonplandia (Corrientes) 7: 10. 1993. TIPO: Brasil. Paraná: Vila Velha, en campo alrededor de la Iglesia, 15 ene. 1987, *A. Krapovickas & C. Cristóbal 40875* (holotipo, MBM!; isotipos, CTES!, MO!, SI!).

Observaciones. Se caracteriza por ser un sufrútice erecto de 60–65 cm alt., 1–5-tallos glabros; con hojas elípticas glabras; vaina estipular con 3–4 laciniás;

inflorescencia largamente pedunculada; hipanto, cáliz y corola externamente micropapilado; disco entero; cápsula glabra y semillas complanadas con alas apicales. Por el porte *Galianthe elegans* es semejante a *G. chodatiana*, pero se diferencian porque *G. elegans* tiene hojas de 6–18 × 2–6 mm, glabras, nervios secundarios inconspicuos (vs. 30–45 × 5–15 mm, escabriúsculas, 3–4 nervios secundarios conspicuos, *G. chodatiana*).

Distribución, hábitat y fenología. Brasil, Paraná, todos los ejemplares conocidos son de Ponta Grossa y alrededores, en campos con suelo arenoso, pedregoso, 500–800 m; florece y fructifica de octubre a enero.

Material representativo estudiado. BRASIL. **Paraná:** Ponta Grossa, 18 oct. 1968, *H. Moreira Filho et al. 472* (CTES, UPCB, US).

7. *Galianthe equisetoides* (Cham. & Schltdl.) E. L. Cabral, Bol. Soc. Argent. Bot. 27(3–4): 242. 1991 [1992]. Basónimo: *Borreria equisetoides* Cham. & Schltdl., Linnaea 3: 338. 1828. *Spermacoce equisetoides* (Cham. & Schltdl.) Kuntze, Revis. Gen. Pl. 3: 123. 1898. TIPO: Brasil. Rio Grande do Sul: Campo dos Barcelos, 9 nov. 1988, *M. L. Abruzzi 1644* (neotipo, designado aquí, HAS!; isotipo, CTES!).

Distribución, hábitat y fenología. Brasil (Paraná y Rio Grande do Sul) y norte de Argentina (Corrientes, en el Sistema Iberá y lugares próximos al río Uruguay); en campos bajos e inundables, 100–1000 m; florece de octubre a febrero, fructifica de marzo a junio (*Borreria equisetoides*, Cabral, 1981: fig. 2).

Observaciones. Es una especie de fácil reconocimiento por ser un sufrútice de 0.60–1.50 m, de aspecto equisetoides, con tallo fistuloso, cilíndrico o subcilíndrico, glabro, constricto en los nudos; con hojas 2–4 por verticilo, cartáceas, filiformes, lineares, nervios secundarios inconspicuos o 2–3 visibles en el envés; inflorescencia terminal, amplia; hipanto y cáliz glabro o pubérulo, corola externamente papilosa, blanca o blanco-lilácea; cápsula glabra o pubérula, con semillas subcilíndricas. Los ejemplares de Brasil presentan tallos más robustos y hojas más anchas de los que viven en Argentina.

El único ejemplar citado en el protologo del basónimo *Borreria equisetoides* se ha destruido en el herbario B, razón por la cual se elige un neotipo coleccionado en Brasil, Rio Grande do Sul, *M. L. Abruzzi 1644*.

Nombres vulgares. En Brasil “sabagueirinho”, “baicurú” (Porto et al., 1977).

Material representativo estudiado. ARGENTINA. **Corrientes:** Ituzaingó, 11 km S de Ruta 12, desvío a Gdor.

Virasoro, 29 nov. 1970, *A. Krapovickas et al. 16568* (CTES, SI). BRASIL. **Paraná:** Volta Grande, dic. 1979, *E. Oliveira 173* (MBM). **Rio Grande do Sul:** Santa María, Reserva Biológica do Ibicuí-Mirim, Barragem de Saturnino, 9 nov. 1988, *N. Silveira 5929* (CTES, HAS).

8. *Galianthe fastigiata* Griseb., *Symb. Fl. Argent.* Abh. Königl. Ges. Wiss. Göttingen 24: 157. 1879. *Borreria fastigiata* (Griseb.) K. Schum., *Fl. Bras. (Martius)* 6(6): 68. 1888. *Spermacoce fastigiata* (Griseb.) Niederl. *Bol. Mens. Mus. Prod. Argent.* 3(31): 306. 1890. TIPO: Argentina. Entre Ríos: Palmar grande, 3 feb. 1876, *P. G. Lorentz 803* (holotipo, HB no visto; isotipo, CORD!).

Borreria leiophylla K. Schum., *Fl. Bras. (Martius)* 6(6): 66. 1888. *Spermacoce leiophylla* (K. Schum.) Kuntze, *Revis. Gen. Pl.* 3: 123. 1898. TIPO: Brasil. Brasilia australi, in provincia Rio Grande do Sul, Joannes de S. Barbara, *Sellow 1570* (lectotipo, designado aqui, F!, foto F 879).

Distribución, hábitat y fenología. Norte de Argentina (Corrientes, Entre Ríos, Misiones), sur de Brasil (Rio Grande do Sul, Santa Catarina), Paraguay oriental (Alto Paraná, Amambay, Caaguazú, Caazapá, Cordillera, Misiones, Paraguari) y Uruguay (Canelones, Cerro Largo, Florida, Lavalleja, Maldonado, Rivera, Rocha, Tacuarembó, Treinta y Tres); en campos de suelos arenosos, rocosos, en palmares de *Butia* y bordes de caminos, 0–1000 m; florece de octubre a febrero, fructifica de marzo a junio.

Observaciones. El carácter sobresaliente de esta especie es su tallo simple de 0.25–1.25 m alt., con hojas opuestas, lanceoladas o lineares, glabras, nervios secundarios inconspicuos; hipanto, cáliz y corola externamente glabros, interior de la corola con pelos densos en tubo y lóbulos; cápsula glabra con semillas subcilíndricas con estrofiolo persistente. Es afín a *Galianthe equisetoides* por los tallos simples, de hojas opuestas, pero se diferencia porque *G. fastigiata* no tiene nudos constrictos (vs. tallos con nudos constrictos en *G. equisetoides*), hojas de 2–25 mm lat., caducas en los nudos inferiores (vs. hojas 2–7(–13) mm lat., persistentes).

Spermacoce fastigiata (Griseb.) Kuntze (Kuntze, 1898) es nom. illeg.

Se usa en medicina popular contra inflamaciones hepáticas (Bacigalupo, 1974).

Nombres vulgares. En Brasil “sabugueirinho do campo” (Porto et al., 1977), en Argentina “sauquito” (de la Peña & Pensiero, 2004).

Material representativo estudiado. ARGENTINA. **Corrientes:** Ituzaingó, Empalme ruta 34 y ruta 14, 22 feb. 1980, *E. Cabral 159* (CTES). **Entre Ríos:** Chajarí, 16 dic. 1957, *A. L. Cabrera 12370* (CTES, SI). **Misiones:** San Ignacio, 18 dic. 1981, *E. Cabral et al. 181* (CTES).

BRASIL. **Rio Grande do Sul:** Morro Sapucaia, p. São Leopoldo, 3 feb. 1956, *B. Rambo 59164* (HBR). **Santa Catarina:** Araranguá, Morro dos Conventos, 3 feb. 1973, *E. M. Detoni 65* (ICN). PARAGUAY. **Alto Paraná:** 1910, *K. Fiebrig 6491* (G). **Amambay:** Cnia. Pedro J. Caballero, mayo 1945, *T. Rojas 12735* (CTES). **Caaguazú:** 55°20'W, 24°35'S, Cnia. Pindo, camino entre Itaquyry y Curuguati, 11 oct. 1995, *A. Schinini et al. 30098* (CTES). **Cordillera:** Valenzuela, 27 jul. 1950, *G. Schwarz 11401* (CTES). **Paraguari:** Tebicuary, 17 nov. 1978, *L. Bernardi 18735* (MO). URUGUAY. **Canelones:** Puerto Jackson, *R. Herter 86625* (G, MVM); río Santa Lucía, 22 feb. 1946, *G. Gallinal et al. 5610* (SP). **Cerro Largo:** 18 ene. 1908, *G. Flossdorf 2* (BAF). **Florida:** Ayo. Mansavillagra, dic. 1946, *B. Rosengurt et al. 5835* (SP). **Lavalleja:** Minas, feb. 1874, *O. Gibert s.n.* (BAF). **Maldonado:** Rincón de Minas, 23 dic. 1928, *C. Osten 20188* (BAF, MVM). **Rocha:** Cerca de la Sierra de las Rochas, 18 ene. 1965, *O. Brescia et al. 3957* (MVFA).

9. *Galianthe gertii* E. L. Cabral, *Bonplandia (Corrientes)* 7(1–4): 13. 1993. TIPO: Brasil. Paraná: Mun. Campina Grande do Sul, Serra Ibitiraquire, 22 ene. 1970, *G. Hatschbach 23388* (holotipo, MBM!; isotipo, RB!).

Distribución, hábitat y fenología. Brasil, Paraná y localidades próximas del estado de Santa Catarina, en campos altos, o en laderas rocosas de 1000–1700 m; florece de noviembre a febrero, fructifica de marzo a abril.

Observaciones. *Galianthe gertii* se individualiza por la vaina estipular de borde irregular terminado en 3–5 lóbulos triangular-lanceolados y también por las inflorescencias tirsoideas umbeliformes, paucifloras de flores rosado-lilacinas o blanquecinas.

Esta especie se dedicó al botánico Gert Hatschbach, quien ha contribuido permanentemente con sus colecciones al conocimiento de las especies de *Galianthe* de Brasil.

Material representativo estudiado. BRASIL. **Paraná:** Mun. Morretes, Serra Marumbi, Pico Olimpo, 10 ene. 1996, *O. S. Ribas et al. 957* (CTES, MBM). **Santa Catarina:** Morro do Iquererim, Campo Alegre, 5 feb. 1958, *R. Reitz & Klein 6426* (B, HBR, MBM, US).

10. *Galianthe grandifolia* E. L. Cabral, *Bonplandia* 7: 14. 1993. TIPO. Brasil. Minas Gerais: Rio Bicudo, ca. 20 km W de Corinto, 3 mar. 1970, *H. S. Irwin et al. 26820* (holotipo, RB!; isotipos, F!, MO!, NY!).

Observaciones. *Galianthe grandiflora* se reconoce fácilmente por ser un sufrútice erecto con tallo de 0.60–1.80 m alt., y con hojas elíptico-lanceoladas o lanceoladas. La inflorescencia es terminal y largamente pedunculada, las cápsulas pubescentes y las semillas complanadas aladas. Se asemeja a *G. centranthoides* por el porte y el tipo de hojas plegado-nervosas, pero *G. grandiflora* tiene tallos simples pubérulos (vs. tallos ramificados, pubes-

5

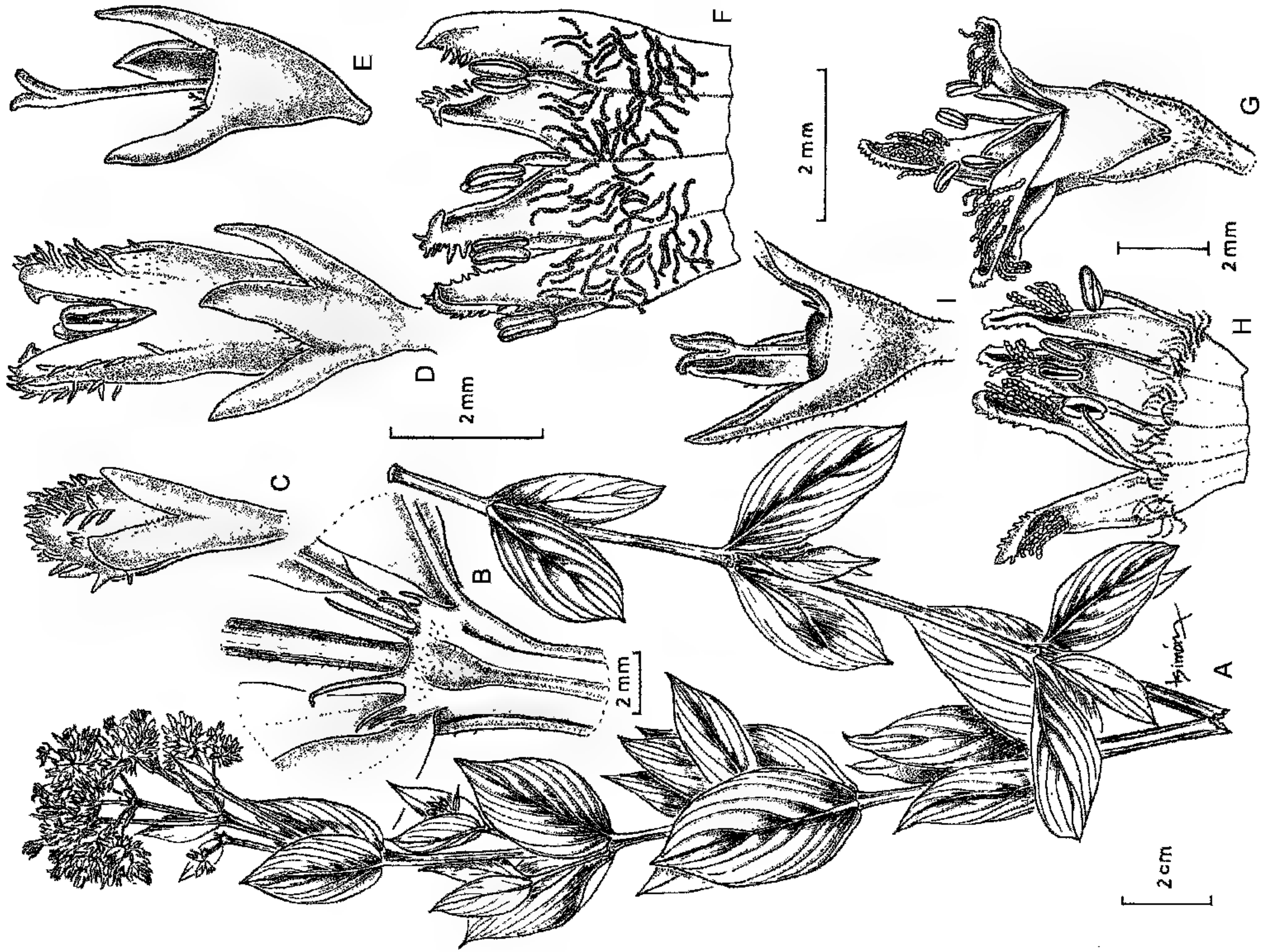

4

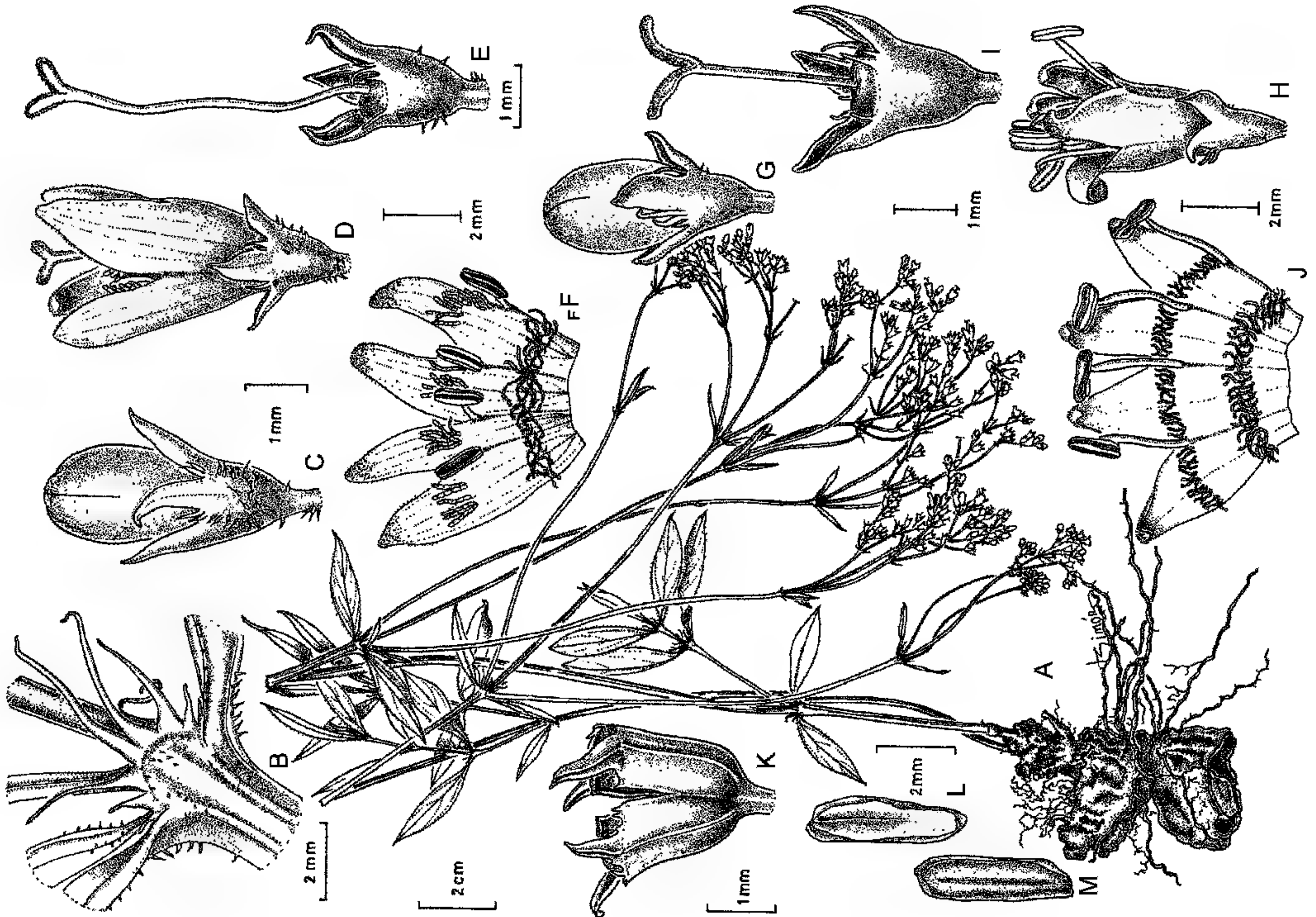

centes, *G. centranthoides*), hojas 40–105 × 5–40 mm, haz glabra o pubérula, envés pubescente (vs. hojas 30–70 × 3–28 mm, pubescentes).

Distribución, hábitat y fenología. Brasil (Bahía, Distrito Federal, Goiás, Mato Grosso, Minas Gerais, Pará, São Paulo, Tocantins); en campos cerrados entre 525 y 1300 m, rupestres, de suelos areno-pedregosos con afloramientos cuarzíticos; florece de septiembre a febrero, fructifica de marzo a mayo.

Material representativo estudiado. BRASIL. **Bahía:** Near Rio Piau, 150 km SW of Barreiras, 14 abr. 1966, *H. S. Irwin et al.* 14782 (MO). **Distrito Federal:** Fda. Agua Limpia, 13 abr. 1976, *J. A. Ratter et al.* 2881 (UEC). **Goiás:** 1846, *G. Gardner* 3785 (G); Mun. Cristalina, 4 feb. 1987, *J. Pirani et al.* 1490 (CTES, MBM). **Mato Grosso:** Serra do Roncador, 24 mayo 1966, *H. S. Irwin et al.* 15952 (SP). **Minas Gerais:** Mun. de Grão Mogol, estrada para o Porto Mandacarú, 11 mayo 1979, *H. C. de Lima et al.* 1020 (RB). **Pará:** 0°95'S, 54°92'W, 4 ago. 1981, *J. Strudwick et al.* 4055 (IAN). **São Paulo:** Itirapina, feb. 1993, *F. de Barros* 2517 (SP). **Tocantins:** Palmas, Serra do Lageado, 13 abr. 1994, *A. E. Ramos et al.* 646 (CTES).

11. *Galianthe guaranitica* (Chodat & Hassl.) E. L. Cabral, *Bol. Soc. Argent. Bot.* 27(3–4): 244. 1991 [1992]. Basónimo: *Borreria guaranitica* Chodat & Hassl., *Bull. Herb. Boissier*, sér. 2, 4: 186. 1904. TIPO: Paraguay. In campo Ipe hú, Sierra de Maracayú, Dec., *E. Hassler* 5594 (holotipo, G!, foto F 6919; isotipos, K!, NY!). Figura 5.

Sufrútice con xilopodio de 0.5–1.5 m alt., tallos simples o escasamente ramificados, tetragonos, glabros o pubescentes, entrenudos (3–)4–8 cm, pseudoverticilados. Hojas (30–)40–50 × (12–)17–27 mm, elípticas, ápice de agudo a atenuado, base redondeada o levemente cordada, subglabras, con escasos pelos dispersos sobre los nervios en el envés, con 5 ó 6 pares de nervios secundarios, en relieve en el envés; vaina estipular prolongada por encima de la separación del par de hojas, 4–5 mm, pubérula, con 7–8 lacinias, de 2–6(–8) mm. Inflorescencias tirsoideas terminales, ± congestas, de 2–6(–10) cm, plurifloras. Hipanto ca. 1.5 mm, turbinado, glabro o pubérulo; cáliz con lóbulos de 1.5–2 mm, triangular-subulados, glabros; corola 5.5–7 mm, lóbulos y tubo ± del mismo largo, con notables papilas sobre el dorso de los lóbulos, característica muy conspicua en los alabastros; disco entero, papiloso. Flor brevistila: corola,

superficie interna con anillo de pelos moniliformes en el tubo y pelos moniliformes más largos en la mitad superior de los lóbulos; anteras 1.2–1.3 mm, filamentos ca. 1.5 mm; estilo ca. 0.5 mm. Flor longistila: corola, superficie interna con pelos moniliformes en el tubo y escasos pelos moniliformes en la base de los lóbulos; anteras subsésiles, 1.2–1.5 mm; estilo ca. 5 mm long. Fruto no visto.

Distribución, hábitat y fenología. Paraguay (Amambay y Canindeyú [Cabral, 1991]) y recién encontrada en el sur de Brasil en Mato Grosso do Sul; en campos cerrados con suelos arenosos, gramínicos, sujetos a quemazones periódicas, 500–700 m; florece y fructifica de diciembre a abril.

Material representativo estudiado. BRASIL. **Mato Grosso do Sul:** Mun. Sidrolândia, Santa Fe, 23 ene. 1971, *G. Hatschbach* 26028 (CTES, MBM, NY, US). PARAGUAY. **Amambay:** Colonia Estrella, 45 km NW de P. J. Caballero, 22°18'S, 55°50'W, 8 dic. 1997, *A. Schinini et al.* 33581 (CTES). **Canindeyú:** Entre Ype-hú y Capitán Bado, a 10 km de Itanará, 5 feb. 1982, *J. Fernández Casas et al.* 5983 (MO, NY).

12. *Galianthe hassleriana* (Chodat) E. L. Cabral, *Bol. Soc. Argent. Bot.* 27(3–4): 244. 1991 [1992]. Basónimo: *Borreria hassleriana* Chodat, *Bull. Herb. Boissier*, sér. 2, 4: 188. 1904. *Borreria hassleriana* Chodat f. *latifolia* Chodat, *Bull. Herb. Boissier*, sér. 2, 4: 189. 1904. TIPO: Paraguay. In campis prope flumen Carimbatay, Sep., *E. Hassler* 4562 (lectotipo, designado aquí, G!; isotipos, K!, NY!, P!, foto F 6918!). Figura 6.

Borreria hassleriana Chodat f. *angustifolia* Chodat, *Bull. Herb. Boissier*, sér. 2, 4: 188. 1904. TIPO: Paraguay. In campo prope flumen Jejuiguazú, dic., *E. Hassler* 5689 (holotipo, G!; isotipos, K!, NY!).

Sufrútice con xilopodio de 35–40 cm alt., tallos simples, glabros o pubérulos, entrenudos 5–10 cm long. Hojas 40–75 × 5–17 mm, pseudoverticiladas, elíptico-lanceoladas o lanceoladas, ápice agudo y base atenuada, glabras, con 2 ó 3 pares de nervios secundarios marcados en el envés; vaina estipular de 3–4 mm, pubescente o pubérula, con pelos más largos hacia el borde, con 3–5 lacinias de (4–)7–10 mm. Inflorescencia tirsoide, terminal. Hipanto 1–1.5 mm, pubescente; cáliz con lóbulos de 1 mm, triangular-acuminados, pubérulos, pubescentes o con pelos dispersos; corola 5–6 mm, papilosa, pubérula o

←

Figura 4. *Galianthe chodatiana*. —A. Planta con xilopodio. —B. Vaina estipular con lacinias. C–F. Flor longistila. —C. Alabastro. —D. Flor. —E. Hipanto, cáliz, estilo y estigma. —F. Interior de la corola desplegada. G–J. Flor brevistila. —G. Alabastro. —H. Flor. —I. Hipanto, cáliz, disco, estilo y estigma. —J. Interior de la corola desplegada. —K. Fruto. L–M. Semilla. —L. Cara ventral. —M. Cara dorsal. (A, B, G–M, *Dusén* 3474; C–F, *Cordeiro* 890.)

Figura 5. *Galianthe guaranitica*. —A. Planta. —B. Vaina estipular con lacinias. C–F. Flor longistila. —C. Alabastro. —D. Flor. —E. Hipanto, cáliz, estilo y estigma. —F. Interior de la corola desplegada. G–I. Flor brevistila. —G. Flor. —H. Interior de la corola desplegada. —I. Hipanto, cáliz, estilo y estigma. (A–F, *Hassler* 5594; G–I, *Schinini* 33496.)

pubescente, papilas densas en el ápice de los lóbulos, lóbulos más cortos que el tubo. Flor brevistila: corola, superficie interna con anillo de pelos moniliformes finos y cortos en la mitad del tubo; anteras ca. 1 mm, filamentos ca. 1.5 mm; estilo 3–3.5 mm. Flor longistila: corola, superficie interna con anillo de pelos moniliformes, finos y cortos en la mitad del tubo y pelos más gruesos en la mitad de los lóbulos; anteras subsésiles, ca. 1 mm; estilo 3.5–4.5 mm. Cápsula 2.5–2.8 mm, subelipsoide, pubescente. Semillas no aladas, ca. 2 mm, estrofiolo persistente.

Distribución, hábitat y fenología. Paraguay, San Pedro; en campos próximos a los ríos Carimbatay y Jejui-Guazú, 190–250 m; florece y fructifica de septiembre a enero.

Observaciones. Chodat (Chodat & Hassler, 1904: 189) describió dos formas para el basónimo *Borreria hassleriana*, que aquí se consideran sinónimos de *Galianthe hassleriana*. En el protologo de *B. hassleriana* f. *latifolia* mencionó el ejemplar "In campis prope flumen Carimbatay, Sept. E. Hassler 4562". En el protologo de *B. hassleriana* f. *angustifolia* citó el ejemplar "In campo prope flumen Jejuiguazú, Dec., E. Hassler 5689". Seleccione como lectotipo *E. Hassler 4562*, por ser un material bien representativo en G y con isotipos vistos en los herbarios K, NY, P.

13. *Galianthe kempffiana* E. L. Cabral, *Brittonia* 57(2): 145–148. 2005. TIPO: Bolivia. Santa Cruz: Velazco, Parque Nacional Noel Kempff M., Serranía de Caparuch, 13 jun. 1994, *T. Killeen, H. González, F. Mamani & P. Soliz 6530* (holotipo, USZ!; isotipos, CTES!, MO!, SI!).

Distribución, hábitat y fenología. Bolivia (Santa Cruz), muy frecuente en el Parque Nacional Noel Kempff Mercado. Brasil (Goiás y Mato Grosso); en campos rupestres de las chapadas de 360–950 m; florece y fructifica de marzo a junio.

Observaciones. Se reconoce por ser un sufrútice de 80–100 cm alt., muy ramificado con ramas secundarias desarrolladas que rematan en inflorescencias congestas y por tener sus hojas con 3 pares de nervios secundarios conspicuos; las semillas son aladas con estrofiolo persistente. Por las ramificaciones y ubicación de las inflorescencias es afín a *Galianthe parvula* E. L. Cabral, pero esta especie es una de las de menor altura, 20–25(–40) cm, las hojas tienen 4–5 pares de nervios secundarios, las semillas no son aladas y tienen el estrofiolo caduco.

Material representativo estudiado. BOLIVIA. **Santa Cruz:** Velazco, Parque Nacional Noel Kempff M., serranía de Huanchaca, 9 jun. 1994, *B. Mostacedo et al. 2160* (MO,

USZ). BRASIL. **Goiás:** Serra Dourada, 16 km S of Goiás Velho, 950 m s.m., 11 mayo 1973, *W. R. Anderson 10109* (F, NY, UB). **Mato Grosso:** Serra da Chapada, 19 feb. 1903, *G. Malme 3446* (F).

14. *Galianthe lanceifolia* E. L. Cabral, *Bol. Soc. Argent. Bot.* 29(3–4): 227. 1993. TIPO: Brasil. Mato Grosso: 1 km de BR-364, camino a Aguas Quentes, 30 ene. 1989, *A. Krapovickas & C. Cristóbal 43/55* (holotipo, MBM!; isotipo, CTES!).

Distribución, hábitat y fenología. Sur de Brasil (Goiás, Mato Grosso do Sul, Mato Grosso, Minas Gerais), en cerrado, en suelos arenosos o pedregosos, 200–1000 m; florece y fructifica de diciembre a julio.

Observaciones. *Galianthe lanceifolia* se reconoce por ser pluricaule, con hojas lanceoladas, inflorescencia en todas las ramas, pero se individualiza cuando fructifica, porque los frutos son subglobosos, notables. Presenta variabilidad en el indumento de hojas, tallo, ejes de la inflorescencia, hipanto y segmentos del cáliz, se observan ejemplares completamente glabros hasta pubescentes, y otros con indumento intermedio. Se asemeja a *G. eupatorioides*, pero *G. lanceifolia* tiene xilopodio (vs. sin xilopodio, *G. eupatorioides*), disco nectarífero entero pubescente (vs. disco bilobado papilado), interior de las flores brevistilas con un anillo de pelos en la mitad del tubo y algunos pelos dispersos en los lóbulos (vs. pelos densos en el tubo hasta la base de los lóbulos).

Nombre vulgar. "Aroeirinha" (observaciones de etiquetas).

Material representativo estudiado. BRASIL. **Goiás:** Luziania, Jardim Marajoara, 22 dic. 1990, *F. Melo et al. 425* (UB). **Mato Grosso:** Cab. do Rio Novo Arinos, feb. 1914, *J. G. Kuhlmann s.n.* (SP 11818). **Mato Grosso do Sul:** Campo Grande, 16 jul. 1966, *R. Goodland 301* (MO, NY). **Minas Gerais:** BR 050, 15 km SE de Uberaba, 29 ene. 1990, *M. M. Arbo et al. 3038* (CTES, HRCB).

15. *Galianthe latistipula* E. L. Cabral, *Bonplandia* (Corrientes) 7(1–4): 18. 1993. TIPO: Brasil. Rio Grande do Sul: Vila Oliva, prope Caixas, 8 feb. 1955, *B. Rambo s.n.* (holotipo, PACA 56661!; isotipos, B!, CTES!, SI!).

Distribución, hábitat y fenología. Sur de Brasil (Rio Grande do Sul y sur de Santa Catarina), en el planalto meridional (Fernandes & Bezerra, 1990), en campos altos, rocosos de 1000–1800 m, florece y fructifica de diciembre a marzo.

Observaciones. Se individualiza por ser esencialmente monocaule, con pseudoverticilos regularmente dispuestos, con hojas de similar tamaño y por la vaina estipular prolongada por encima de la separación del par de hojas. Es semejante a *Galianthe fastigiata*, por

el tallo simple, y hojas glabras, pero se diferencia porque *G. latistipula* tiene una vaina estipular con una lacinia central, triangular, largamente acuminada (vs. 5–7 lacinias más o menos iguales en *G. fastigiata*), semillas complanadas con alas apicales (vs. semillas subcilíndricas, ápteras).

Material representativo estudiado. BRASIL. **Rio Grande do Sul:** Soledade, 13 feb. 1951, *B. Rambo 50047* (B, CTES, LIL, PACA). **Santa Catarina:** Campos Novos, 31 ene. 1963, *R. Reitz 6416* (HBR, US).

16. *Galianthe liliifolia* (Standl.) E. L. Cabral, Bol. Soc. Argent. Bot. 27(3–4): 245. 1991 [1992]. Basónimo: *Borreria liliifolia* Standl., Publ. Field Columbian Mus., Bot. Ser. 8(5): 392. 1931. TIPO: Brasil. São Paulo: Ipiranga, 31 dic. 1911, *Alex Brade 5266* (holotipo, S!; isotipos, F!, SP!). Figura 7.

Sufrútice con xilopodio, 50–60 cm alt., 1- ó 2-caules, sin ramas secundarias desarrolladas, tallo tetragono o subtetragono, pubérulo. Hojas 20–65(–90) × 5–15 mm, pseudoverticiladas, oblongo-lanceoladas, de ápice agudo a atenuado y base de aguda a obtusa, pubérulas, discoloras, haz ferrugínea cuando secas, con 4 ó 5 nervios secundarios ± paralelos, impresos en el envés, surcados en la haz; vaina estipular de 3–6 mm, pubérula, con 7–10 lacinias pubérulas, de 4–12 mm. Inflorescencia terminal amplia. Hipanto 1–2 mm, turbinado, papiloso o pubérulo; cáliz con lóbulos de 1–2 mm, triangular-subulados; corola lóbulos más largos que el tubo, internamente con anillo de pelos moniliformes en el tubo; disco entero. Flor brevistila: corola ca. 3.5 mm; anteras 0.6–1 mm, filamentos ca. 1 mm; estilo ca. 1.5 mm. Flor longistila: corola 2.5–3 mm; anteras subsésiles, ca. 1 mm; estilo ca. 2.5 mm. Cápsula 2.5–3 mm, papilosa; semillas 2–2.5 mm, plano convexas, alas reducidas en el ápice, con estrofiolo persistente, cubriendo la cara ventral.

Distribución, hábitat y fenología. Centro y sur de Brasil (Distrito Federal, Minas Gerais y São Paulo), planalto central, en el cerrado o terrenos modificados al borde de caminos, de 900–1370 m; florece de noviembre a enero, fructifica de febrero a abril.

Observaciones. *Galianthe liliifolia* se reconoce fácilmente por sus tallos simples, pubérulos, ferrugíneos, por sus hojas pseudoverticiladas, oblongo-lanceoladas, pubérulas, marcadamente discoloras y por su amplia inflorescencia terminal.

Material representativo estudiado. BRASIL. **Distrito Federal:** Patio do CENARGEN, 23 nov. 1976, *A. Allem 529* (UB). **Minas Gerais:** Lagoa Santa, 3 feb. 1864, *E. Warming s.n.* (P). **São Paulo:** Itapetininga, I-1960, *S. M. Campos 148* (G, NY, SP, US).

17. *Galianthe linearifolia* E. L. Cabral, Bonplandia (Corrientes) 7(1–4): 20. 1993. TIPO: Paraguay. Alto Paraná: Ea. Santa Elena, Pira Pyta, 54°35'W, 25°17'S, 11 oct. 1990, *A. Schinini & G. Caballero Marmorì 27227* (holotipo, CTES; isotipos, G!, MO!).

Distribución, hábitat y fenología. Paraguay (Alto Paraná), poco frecuente en campos altos, 400–500 m, con palmares de *Butia paraguayensis* de donde procede la colección reciente. Con respecto al material de Argentina, corresponde a una colección principios del siglo XX en la provincia de Misiones, y aún no se ha vuelto a encontrar; florece y fructifica de septiembre a enero.

Observaciones. *Galianthe linearifolia* como su nombre lo indica se reconoce por ser un sufrútice ramificado, formando matas, con hojas lineares, pseudoverticiladas, cuando secas son verde-amariillentas y por su inflorescencia apical, largamente pedunculada, los frutos son glabros con semillas complanadas y aladas en los ápices. Por las ramas secundarias opuestas con braquiblastos muy reducidos se parece a *G. thalictroides* (K. Schum.) E. L. Cabral, pero *G. linearifolia* tiene hojas pubescentes de 5–10 × 0.2–2 mm (vs. glabras, (8–)20–35 × 0.7–2 mm en *G. thalictroides*), interior de corola de flores brevistilas con pelos en el tubo (vs. pelos en el tubo y en los lóbulos de corola brevistila).

Material representativo estudiado. ARGENTINA. **Misiones:** Apóstoles, Azara, *C. Spegazzini s.n.* (LP). PARAGUAY. **Alto Paraná:** Tatí Yupí, 24 sep. 1980, *G. Caballero Marmorì 860* (CTES).

18. *Galianthe longifolia* (Standl.) E. L. Cabral, Bol. Soc. Argent. Bot. 27(3–4): 245. 1991 [1992]. Basónimo: *Borreria thalictroides* var. *longifolia* Standl., Publ. Field Columbian Mus., Bot. Ser. 8(5): 394. 1931. TIPO: Brasil. Paraná: Serriha, in campo, 840 m, 7 dic. 1908, *P. Dusén 7303* (holotipo, S!; isotipo, US!). Figura 8.

Sufrútice con xilopodio de 40–60 cm alt., tallos subtetragonos, simples, glabros. Hojas de (15–)25–65 × 0.5–1 mm, lineares, nervios secundarios inconspicuos, glabras; vaina estipular de 4.5–6.5 mm, pubérula, de borde irregular con 3–4 lacinias de 5–15 mm. Inflorescencia tirsoide, terminal, con pedúnculos de 2–4 cm. Hipanto 1.2–1.7 mm, turbinado, glabro; cáliz con lóbulos 1.2–1.5 mm, triangular-acuminados, glabros, con papilas antrorsas sobre el borde; corola, superficie interna con anillo de pelos moniliformes, delgados, en la mitad del tubo y pelos más gruesos, largos, en arco en los lóbulos; disco entero. Flor brevistila: corola 3.5–4 mm, lóbulos iguales o más cortos que el tubo; anteras 0.5–0.7 mm, filamentos ca. 0.5 mm; estilo 1.2–2 mm. Flor longistila: corola 3.7–4.5 mm, lóbulos iguales o

7

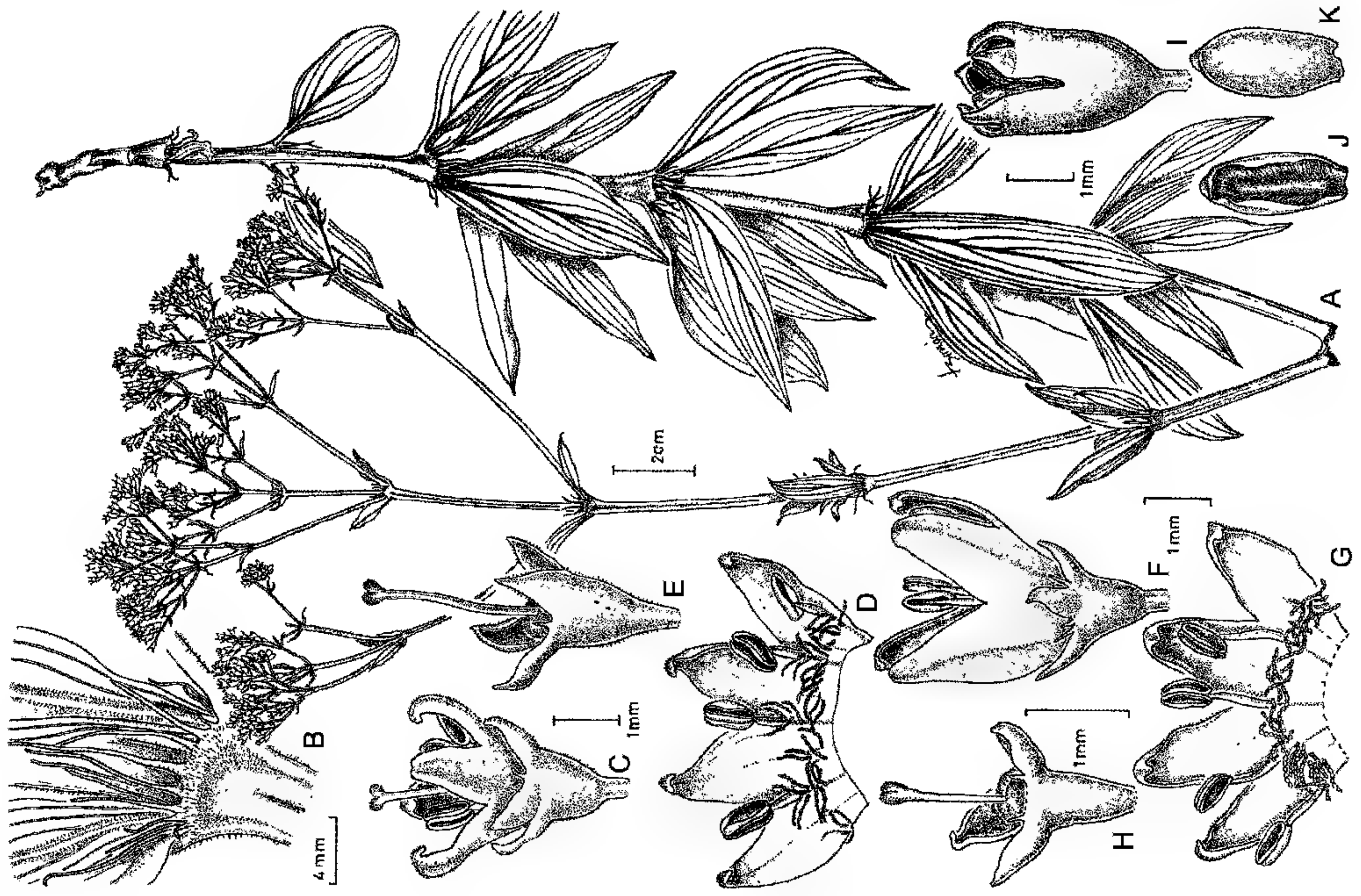

6

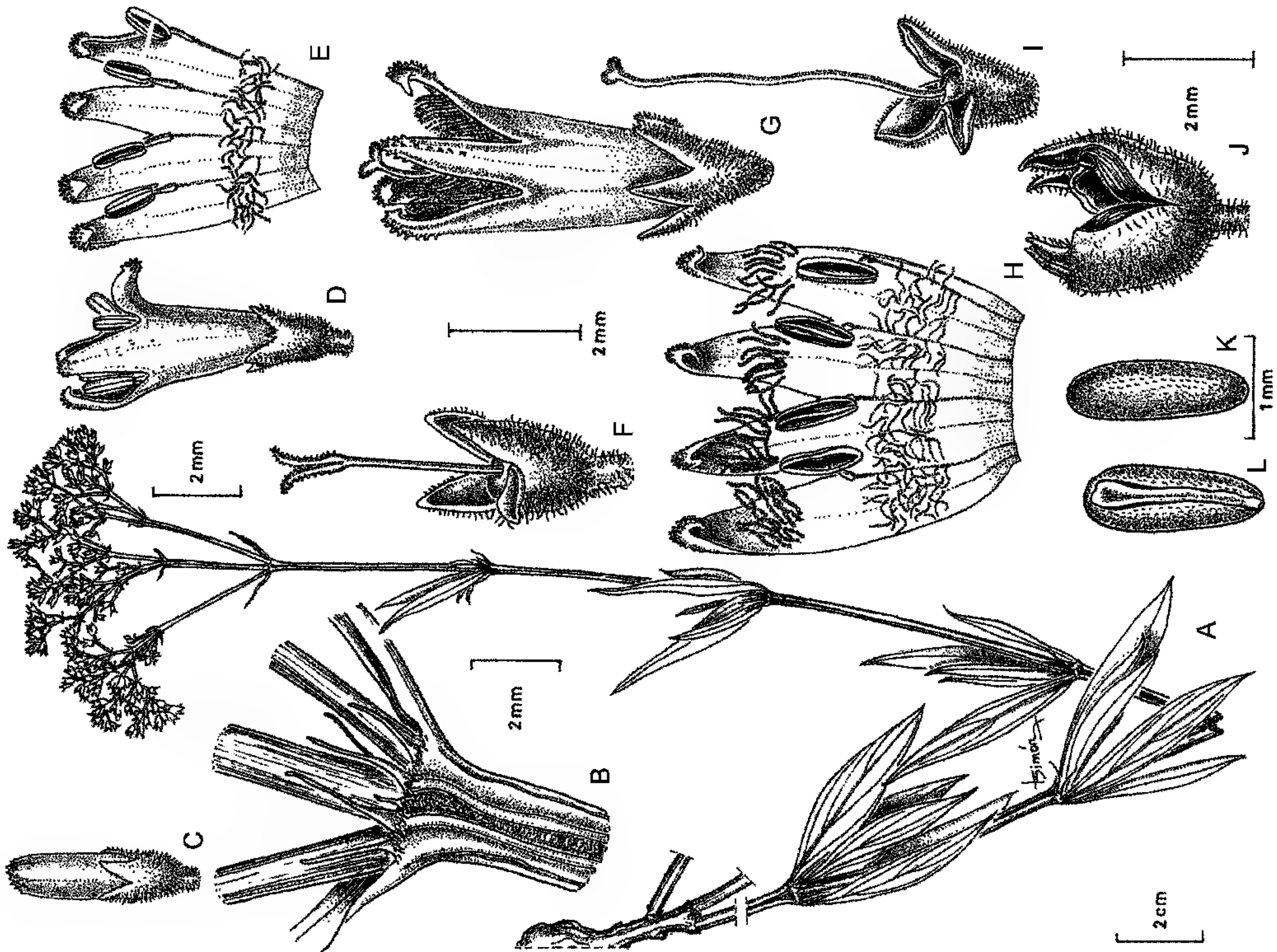

más largos que el tubo; anteras subsésiles, ca. 0.7 mm; estilo 3.7–4(–5.2) mm. Fruto no visto.

Distribución, hábitat y fenología. Sur de Brasil (Paraná y Mato Grosso do Sul), en campos altos de 840–875 m, en áreas ocupadas por “pinheiros” *Araucaria angustifolia* (Bertol.) Kuntze; florece y fructifica de noviembre a abril.

Material representativo estudiado. BRASIL. **Mato Grosso do Sul:** Rod. MF 642, 5 Km O, Tacuru, 16 dic. 1983, *G. Hatschbach* 47302 (MBM, UB). **Paraná:** Palmeira, 28 nov. 1948, *G. Hatschbach* 1113 (HBR, MBM, US).

19. *Galianthe longisepala* E. L. Cabral, Bonplandia (Corrientes) 13: 15–17. 2004. TIPO: Brasil. Goiás: Serra dos Cristais, 2 km N of Cristalina, 1250 m, 2 mar. 1966, *H. S. Irwin et al.* 13307 (holotipo, UB!; isotipos, F!, MO!, NY!, RB!, US!).

Distribución, hábitat y fenología. Centro de Brasil (Goiás y Minas Gerais), en campos cerrados, en suelos lateríticos y con afloramiento rocosos de 1050–1250 m; florece y fructifica de enero a marzo.

Observaciones. Esta especie se reconoce fácilmente por las inflorescencias congestas y por los frutos con sépalos largos y reflexos; en material herborizado se diferencia por el color de los nervios en el envés, castaño-negrusco, marcadamente contrastante con el resto de la superficie foliar; es afín a *Galianthe lanceifolia*, de la que se diferencia porque *G. longisepala* tiene hojas glabras de 3–8 mm lat. (vs. hojas pubérulas o pubescentes, 8–18 mm lat., en *G. lanceifolia*).

Material representativo estudiado. BRASIL. **Minas Gerais:** Morro das Pedras, ca. 25 km NE of Patrocínio, 1050 m, 28 ene. 1970, *H. S. Irwin et al.* 25504 (NY, RB, UB, US).

20. *Galianthe macedoi* E. L. Cabral, Bonplandia (Corrientes) 10(1–4): 121–123. 2000. TIPO: Brasil. Goiás: Jataí, Faz. Queixada, 10 dic. 1948, *A. Macedo* 1468 (holotipo, SP!; isotipos, CTES!, F!, IAC 28270!, NY!, SP!).

Observaciones. Se caracteriza por ser un sufrútice monocaule, hojas oblongo-lanceoladas de base obtusa o truncada, con nerviación paralelodroma y con fruto subcilíndrico, glabro, semillas con alas muy breves; es

afín a *Galianthe grandifolia* por el tallo simple con hojas opuestas, sin brotes axilares, pero *G. macedoi* tiene 60–80 cm alt. (vs. 0.80–2.50 m alt. en *G. grandifolia*); hojas glabras de 7–20 mm lat. (vs. hojas con haz glabra o pubérula, envés pubescente de 5–40 mm lat.).

Distribución, hábitat y fenología. Centro de Brasil (Goiás) en campos bajos cerca de ríos, 900–1000 m; florece y fructifica de diciembre a mayo.

Material representativo estudiado. BRASIL. **Goiás:** 25 km SW of Caiaponia, 1 mayo 1973, *W. R. Anderson* 9599 (UB, US 2774976, US 2774977).

21. *Galianthe matogrossiana* E. L. Cabral, Bonplandia (Corrientes) 13(1–4): 17–19. 2004. TIPO: Brasil. Mato Grosso do Sul: Sidrolândia, Agua Rica, 12 abr. 1972, *G. Hatschbach* 29439 (holotipo, MBM!; isotipos, US 2745683!, US 2835289!).

Observaciones. *Galianthe matogrossiana* se reconoce por ser un sufrútice erecto, 1–2-caules, de 0.8–1 m alt., con hojas de 55–90 × 1–26 mm, opuestas sin braquiblastos, elípticas, glabras, con vaina estipular prolongada por encima de la separación del par de hojas, hipanto pubérulo, corola externamente micropapilosa; fruto pubescente con semillas complanadas. Es similar a *G. guaranitica* por los nervios secundarios marcados y por vaina prolongada, pero se diferencian porque *G. matogrossiana* tiene hojas con base atenuada (vs. hojas de base redondeada o levemente cordada en *G. guaranitica*), alabastro con papilas largas sobre los lóbulos (vs. alabastro con papilas cortas sobre los lóbulos).

Distribución, hábitat y fenología. Sur de Brasil (Mato Grosso do Sul), en campos, 200–460 m; florece y fructifica de diciembre a abril.

Material representativo estudiado. BRASIL. **Mato Grosso do Sul:** 22 km W de Ribas do Rio Pardo, 25 ene. 1979, *A. Krapovich et al.* 34386 (CTES, SI).

22. *Galianthe montesii* E. L. Cabral, Candollea 58: 392. 2003. TIPO: Paraguay. Alto Paraná: Ñacunday, 18 nov. 1950, *J. E. Montes* 9764 (holotipo, CTES!; isotipo, LIL!).

←

Figura 6. *Galianthe hassleriana*. —A. Planta. —B. Vaina estipular con lacinias. C–F. Flor brevistila. —C. Alabastro. —D. Flor. —E. Interior de la corola desplegada. —F. Hipanto, cáliz, estilo y estigma. G–I. Flor longistila. —G. Flor. —H. Interior de la corola desplegada. —I. Hipanto, cáliz, estilo y estigma. —J. Fruto. K–L. Semilla. —K. Cara dorsal. —L. Cara ventral. (A–F, *Hassler* 4562; G–L, *Hassler* 5689.)

Figura 7. *Galianthe liliifolia*. —A. Planta. —B. Vaina estipular con lacinias. C–E. Flor longistila. —C. Alabastro. —D. Interior de la corola desplegada. —E. Hipanto, cáliz, estilo y estigma. F–G. Flor brevistila. —F. Flor. —G. Interior de la corola desplegada. —H. Hipanto, cáliz, estilo y estigma. —I. Fruto. J–K. Semilla. —J. Cara ventral. —K. Cara dorsal. (A–E, *Irwin* 12244; F–K, *Brade* 6783.)

9

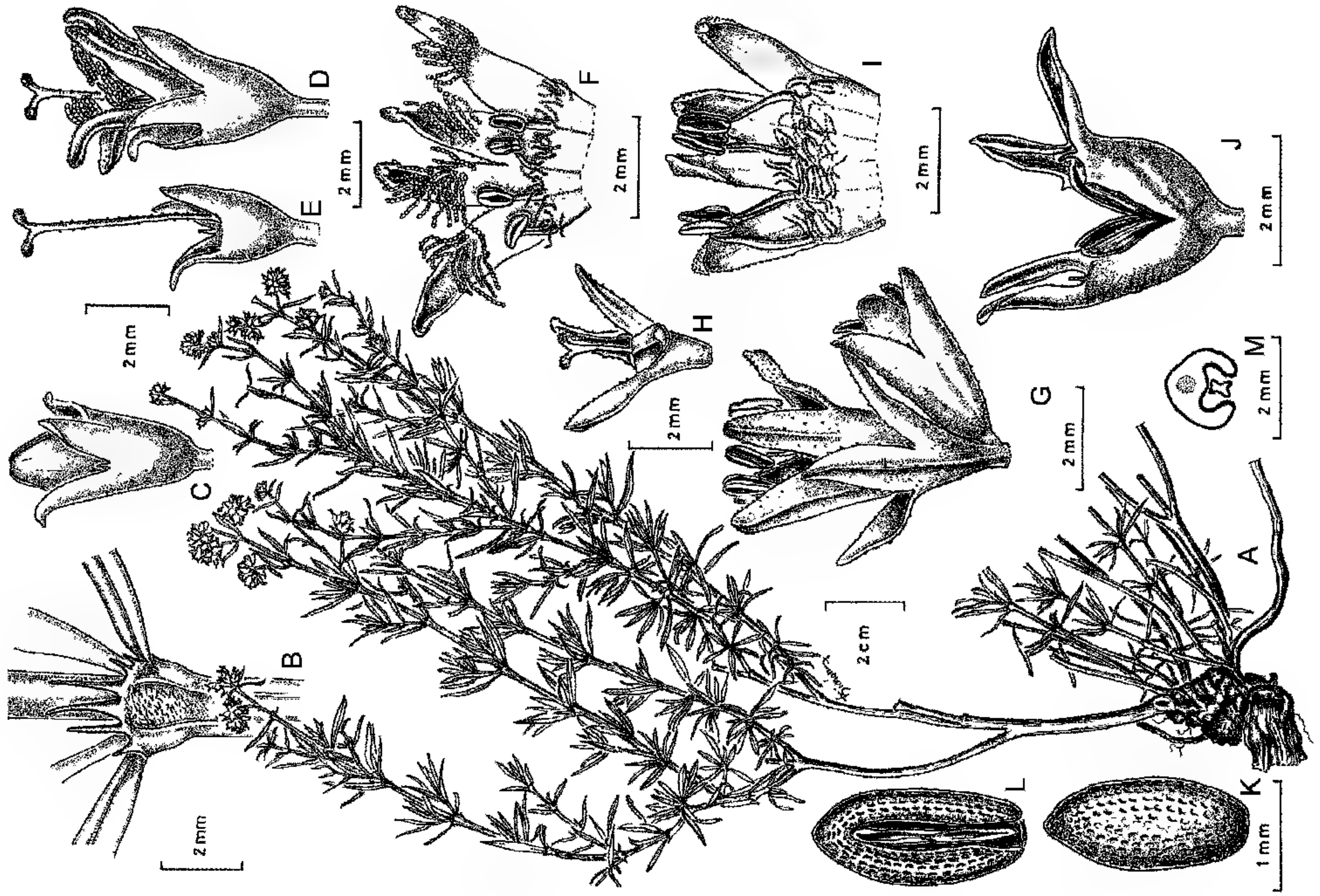

8

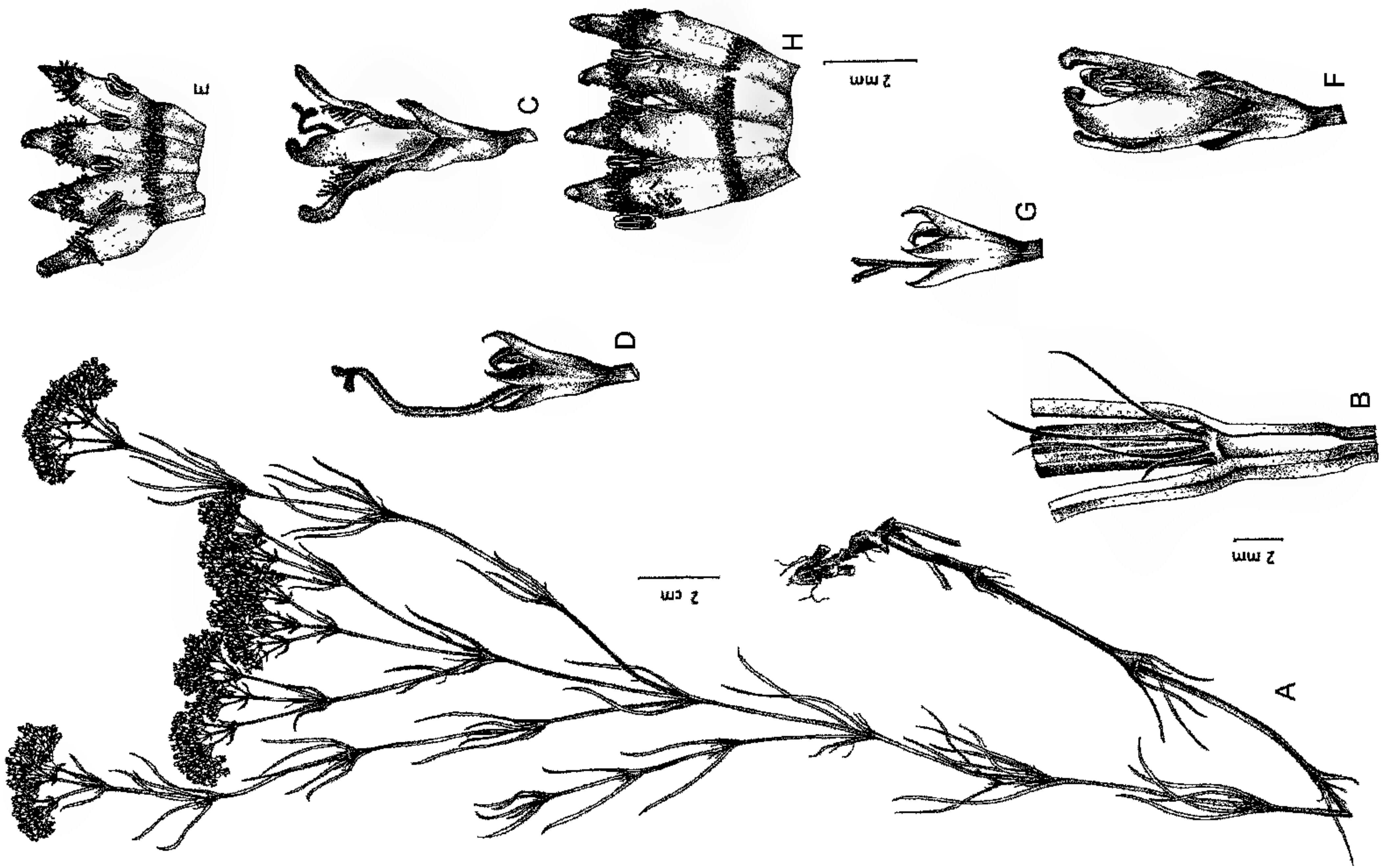

Observaciones. Esta especie se caracteriza por ser un sufrútice ramificado de 0–80 cm alt., de hojas linear-lanceoladas de 3–4 mm lat., pubérulas o escabrosas, hipanto y frutos pubescentes; semillas comprimidas, aladas. Es semejante a *Galianthe thalictroides*, por las ramas secundarias opuestas, desarrolladas y por las hojas lineares, pero esta especie es más robusta, forma matas densas, tiene las hojas de 0.7–2 mm lat., glabras, el hipanto y fruto glabros.

Distribución, hábitat y fenología. Nordeste de Argentina (Misiones) y Paraguay oriental (Alto Paraná), en campos altos, con suelo arenoso laterítico de 200–600 m; florece y fructifica de octubre a enero.

Material representativo estudiado. ARGENTINA. **Misiones:** Gral. Manuel Belgrano, San Antonio, 2 Oct. 1949, J. E. Montes 7036 (CTES, SI).

23. *Galianthe parvula* E. L. Cabral, Bonplandia (Corrientes) 7(1–4): 24. 1993. TIPO: Paraguay. Amambay: Sierra de Amambay, Estrella, ene. 1908, T. Rojas 10082 (holotipo, G!).

Distribución, hábitat y fenología. Paraguay oriental (Amambay, San Pedro) y se ha encontrado también en el sur de Brasil (Mato Grosso do Sul), en campos cerrados, campos rocosos en laderas de colinas, de 300–1000 m; florece de octubre a enero, fructifica de febrero a junio.

Observaciones. Se la reconoce por ser un sufrútice muy ramificado, 10–20-caule; hojas de 12–25 × 4–10 mm, elípticas o elíptico-lanceoladas, glabras, por las inflorescencias paucifloras, breves, congestas en todas las ramas; hipanto irregularmente pubescente, corola externamente papilosa y por la cápsula globosa, pilosa. Por las ramificaciones y ubicación de las inflorescencias es afín a *Galianthe kempffiana*; pero *G. parvula* tiene tallos glabros 20–40 cm alt. (vs. tallos pubescentes, 80–100 cm alt. en *G. kempffiana*); hojas 4–5 pares de nervios secundarios (vs. 3 pares de nervios secundarios); semillas ápteras con estrofiolo caduco (vs. semillas aladas con estrofiolo persistente).

Material representativo estudiado. BRASIL. **Mato Grosso do Sul:** Mun. Ponta Pora, 16 km do estrada a Campo Grande, 22°32'0"S, 55°41'0"W, cerrado, 18 nov.

1963, J. Correa Gomes Jr. 1437 (UB). PARAGUAY. **Amambay:** El Buracón, 30 km W de Pedro Juan Caballero, 15 dic. 1983, G. Hatschbach 47282 (MBM, MO, UB). **San Pedro:** Yaguareté Forest, 23°48'38"S, 56°07'00"W, 20 jun. 1995, E. Zardini et al. 42813 (CTES, MO, PY).

24. *Galianthe peruviana* (Pers.) E. L. Cabral, Bonplandia (Corrientes) 10(1–4): 123–124. 2000. Basónimo: *Spermacoce peruviana* Pers., Syn. Pl. 1: 124. 1805, nom. inmutat. *Borreria peruviana* (Pers.) L. B. Sm. & Downs, Sellowia 7: 78. 1956. TIPO: Perú. In peruviae montibus ad Muña vicum, in ruderatis & runcationibus Cormillâ & Rinconadâ, Ruiz & Pavón s.n. (holotipo, MA!; isotipos, B-W!, F!). Figura 9.

Borreria corymbosa DC., Prodr. 4: 550. 1830. TIPO: Peru. In Peruviae montibus, Ceron, Haenke s.n. (holotipo, G-DC!).

Borreria ericoides Cham. & Schltld., Linnaea 3(4): 326. 1828. TIPO: In Brasilia aequinoctiali, Sellow s.n. (lectotipo, designado aquí, LE!; isotipo, G-DC!).

Sufrútice con xilopodio, muy ramificado, pluricaule de 10–20-caule, de 10–35(–55) cm alt., tallos de pubérulos a glabros, con entrenudos de (0.5–)3–20 mm. Hojas pseudoverticiladas, 4–20(–25) × (0.3–)0.5–0.9(–3) mm, filiformes, lineares o lanceoladas, margen revoluto, ápice y base agudos, glabras, pubérulas o pubescentes, nervio medio prominente en el envés, surcado en la haz, nervios secundarios inconspicuos; vaina estipular de 1–2.5 mm long., pubérula o pubescente, con 3–6 lacinias de 1–3.2 mm, glabras, rojizas. Inflorescencias tirsoideas, congestas, terminales. Hipanto 1.2–1.7 mm, turbinado, glabro o pubérulo; cáliz de lóbulos triangular-subulados de 1.2–1.5 mm; corola 3–4 mm, con papilas formando crestas sobre el dorso de los lóbulos, lóbulos iguales o más cortos que el tubo; disco entero. Flor brevistila: interior de la corola con pelos moniliformes desde la base de los lóbulos hasta la mitad del tubo; anteras de 1–1.5 mm, filamentos ca. 1 mm, estilo 1–2 mm. Flor longistila: interior de la corola con pelos moniliformes más gruesos en los lóbulos y pelos delgados en la mitad del tubo; anteras subsésiles, ca. 1 mm; estilo 3–4 mm. Cápsula 2–2.5 mm, subglobosa, pubérula o glabra; semillas 2–2.2 mm, subcilíndricas, notablemente escrobiculadas,

←

Figura 8. *Galianthe longifolia*. —A. Planta. —B. Vaina estipular con lacinias. C–D. Flor longistila. —C. Flor. —D. Hipanto, cáliz, estilo y estigma. —E. Interior de la corola desplegada. F–H. Flor brevistila. —F. Flor. —G. Hipanto, cáliz, estilo y estigma. —H. Interior de la corola desplegada. (A–E, Dusén, 4167; F–H, Krapovickas 40856.)

Figura 9. *Galianthe peruviana*. —A. Planta. —B. Vaina estipular con lacinias. C–F. Flor longistila. —C. Alabastro. —D. Flor. —E. Hipanto, cáliz, estilo y estigma. —F. Interior de la corola desplegada. G–I. Flor brevistila. —G. Flor y alabastro. —H. Hipanto, cáliz, estilo y estigma. —I. Interior de la corola desplegada. —J. Fruto. K–M. Semilla. —K. Cara dorsal. —L. Cara ventral. —M. Corte transversal. (A–B, J–M, Arbo 4167; C–F, Irwin 22949; G–I, Irwin 24802.)

cara dorsal convexa, cara ventral plana con surco alrededor del estrofiolo persistente.

Distribución, hábitat y fenología. Bolivia (Santa Cruz), Brasil (Goiás, Minas Gerais, São Paulo), en Perú (Cuzco, Huancavelica, Huánuco, Junín), en campos altos con suelos rocosos; en Brasil en campos cerrados, en suelos con afloramientos rocosos en el planalto central de 900–1600 m, en Bolivia en laderas de los valles interandinos de 1550–2250 m y en Perú en el estrato herbáceo generalmente en zonas de pendiente con afloramientos rocosos, entre 1500–3000 m; florece y fructifica de septiembre a mayo.

Observaciones. Posiblemente debido a la extensa distribución en lugares altos, esta especie presenta una notable variabilidad en el porte, desde plantas pluricaules sin ramas secundarias hasta ramas muy desarrolladas que rematan en inflorescencias congestas, desde aspecto ericoide hasta con notables entrenudos. También las hojas presentan tamaño y pubescencia variables.

Discusión. Por considerar que el original de *Borreria ericoides* ha desaparecido en el herbario B, se elige como lectotipo, el ejemplar del herbario LE, por estar completo y en buen estado de conservación.

Spermacoce corymbosa Ruiz & Pav., Fl. Peruv. [Ruiz & Pavon] 1: 60, tab. 91, fig. a. 1798 y *Galianthe corymbosa* (Ruiz & Pav.) E. L. Cabral, Bol. Soc. Argent. Bot. 27: 241, 1991 [non *Spermacoce corymbosa* L., Sp. Pl. (ed. 2) 1: 149. 1762] son nom. illeg.

Material representativo estudiado. BOLIVIA. **Santa Cruz:** Prov. Caballero, 3 km NE of Abra de Quiñe, 18°04'S, 64°19'30"W, 31 dic. 1995, *M. Nee 46651* (CTES, LPB, NY). BRASIL. **Goiás:** Mun. de Alto Paraiso, Nova Roma, 20 feb. 1991, *B. A. S. Pereira et al. 1476* (IBGE). **Minas Gerais:** Serra de Moeda, *F. Sellow 1735* (LE); Lagoa Santa, 14 dic. 1971, *J. Semir 561* (UEC). **São Paulo:** 1884, *A. Glaziou 17640* (P). PERU. **Cuzco:** Urubamba, Machupichu, II-1938, *L. Vargas 790* (MO). **Huancavelica:** Tayacaja, 14 abr. 1954, *O. Tovar 1810* (MO). **Huánuco:** Camino a Panao, 2650 m alt., 7 sep. 1948, *R. Scolnik 1048* (CORD). **Junín:** Manto, 11 jul. 1961, *F. Woytkowski 6536* (MO).

25. *Galianthe pseudopeciolata* E. L. Cabral, Bonplandia (Corrientes) 7(1–4): 26. 1993. TIPO. Paraguay. Amambay: Sierra de Amambay, ene. 1908, *E. Hassler 10102* (holotipo, G!; isotipos, F!, LIL!, NY!, P!).

Distribución, hábitat y fenología. Paraguay (Amambay, Caaguazú) y sur de Brasil (Mato Grosso do Sul, Paraná, São Paulo), en lugares abiertos e inundables, en terrenos pantanosos o en borde de ríos y arroyos, de 200–1600 m; florece de noviembre a febrero, fructifica de marzo a abril.

Observaciones. *Galianthe pseudopeciolata* se reconoce por ser un sufrútice erecto de 1–1.70 m alt., de tallo simple, subtetrágono, glabro; hojas de 3–13 cm long., lanceoladas u oblongo-lanceoladas, de base largamente atenuada formando un pseudopeciolo, haz glabra, envés escabriúsculo sobre los nervios y márgenes; cápsula glabra y semillas aladas. Por su hábito robusto es muy afín a *G. valerianoides* (Cham. & Schltld.) E. L. Cabral, ambas viven en campos bajos, pero es fácil distinguirlas porque esta última especie tiene hojas de base truncada u obtusa y además tiene el tallo con pelos retrorsos en los ángulos.

Material representativo estudiado. BRASIL. **Mato Grosso do Sul:** Maracajú, 29 dic. 1973, *D. Sucre 10523* (RB). **Paraná:** Curitiba, Bairro Alto, 31 nov. 1973, *G. Hatschbach 33914* (MBM). **São Paulo:** Campos do Jordão, abr. 1945, *E. Leite 3468* (LIL). PARAGUAY. **Amambay:** Pedro Juan Caballero, 8 feb. 1951, *G. J. Schwarz 11791* (CTES, LIL). **Caaguazú:** Yhú, *P. Jörgensen 4922* (F, MO, NY, SI, US).

26. *Galianthe ramosa* E. L. Cabral, Bol. Soc. Argent. Bot. 29(3–4): 225. 1993. TIPO: Brasil. Goiás: BR 040, 12 km al S de Luziania, ca. 1000 m, cerrado sucio, 1 feb. 1990, *M. M. Arbo, R. Monteiro, A. Schinini & A. Furlan 3366* (holotipo, HRCB!; isotipo, CTES!).

Distribución, hábitat y fenología. Centro de Brasil (Goiás, Distrito Federal, Minas Gerais, Mato Grosso do Sul), en campos cerrados, sujeto a incendios periódicos, 800–1205 m; florece de octubre a febrero, fructifica de marzo a mayo.

Observaciones. Se caracteriza por ser un sufrútice de 12–30 cm alt., muy ramificado, 5–20-caule; hojas ovadas o elíptico-lanceoladas, 15–42 × 4.5–18 mm; vaina estipular 2–3 mm, con 5–6 lacinias filiformes, pubérulas. Es afín a *Galianthe centranthoides*, por la pubescencia en toda la planta y por las hojas plegado-nervosas, pero se diferencian porque *G. ramosa* tiene ramas secundarias escasas a nulas (vs. ramas secundarias muy desarrolladas en *G. centranthoides*), inflorescencia congesta (vs. inflorescencia amplia), corola 2–3 mm (vs. corola 4.5–6.5 mm), semillas subcilíndricas ápteras (vs. semillas complanadas, aladas).

Material representativo estudiado. BRASIL. **Distrito Federal:** Brasilia, próxima a Reserva Ecológica de IBGE, 21 Sep. 1981, *E. Heringer 15742* (IBGE, MBM, SP, UEC). **Goiás:** Curso del Rio Porto, 20 Nov. 1894, *C. Glaziou 12906* (P). **Mato Grosso do Sul:** Amambaí, 1979, *W. G. García 14024* (UEC). **Minas Gerais:** BR 050, 65 km N de Uberaba, 29 ene. 1990, *M. M. Arbo 3024* (CTES, HRCB).

27. *Galianthe reitzii* E. L. Cabral, Bonplandia (Corrientes) 10(1–4): 124–126. 2000. TIPO: Brasil. Santa Catarina: Municipio Urubici, Serra

do Oratorio, Bom Jardim, 9 dic. 1958, *R. Reitz & R. Klein 7688* (holotipo, HBR!; isotipos, G!, US!).

Observaciones. Se caracteriza por ser un sufrútice muy ramificado de 0.20–1 m alt., con hojas pseudoverticiladas, lineares, coriáceas, glabras; vaina estipular 1–1.5 mm, pubérula, con 1 lacinia central de 1.5–1.8 mm y dos apéndices laterales poco desarrollados, con coléteres apicales; es afin a *Galianthe peruviana*, por ser sufrútices muy ramificados, con hojas pseudoverticiladas, lineares, pero se diferencian porque *G. reitzii* tiene vaina estipular con 3 lacinias subuladas desiguales (vs. 3–6 lacinias filiformes más o menos iguales en *G. peruviana*), corola 5–6 mm (vs. corola 3–4 mm), interior de la corola brevistila dos anillos de pelos, uno en la mitad del tubo y otro en la base de los lóbulos (vs. un solo anillo de pelos desde la base de los lóbulos hasta la mitad del tubo).

Distribución, hábitat y fenología. Sur de Brasil (Santa Catarina), en la "Serra Peral", en afloramientos rocosos con altitudes que varían entre 1000 a 1822 m, zona del Parque Nacional de São Joaquim, es considerada la región más fría y el único lugar donde se producen nevadas en Brasil (IBAMA, 1998); florece y fructifica de diciembre a abril.

Material representativo estudiado. BRASIL. **Santa Catarina:** Municipio Urubici, Cuesta a Bom Jardim da Serra, 20 ene. 1975, *Z. Ahumada et al. 3361* (CTESN, SI); Morro da Igreja, 3 ene. 1949, *R. Reitz 2969* (B, HBR, US).

28. *Galianthe souzae* E. L. Cabral & Bacigalupo, *Bol. Soc. Argent. Bot.* 34: 153–154. 2000. TIPO: Brasil. São Paulo: Apiaí, Distr. Barra do Chapéu, ca. 8 km de Bonsucesso de Itararé, 3 jun. 1994, *V. C. Souza, P. Miyagi, E. Moncaio 6112* (holotipo, SP!; isotipos, CTES!, UEC!).

Observaciones. Se caracteriza por ser un sufrútice de 50–80 cm alt., de tallos simples, fistulosos, glabros, con las hojas basales caducas, la vaina estipular con 3–5 lacinias soldadas en la porción basal y las corolas rosadas o lilacinas, esta última característica es poco frecuente en el género. Por su tallo simple, forma y tamaño de las hojas es semejante a *Galianthe valerianoides*, pero se diferencian porque *G. souzae* tiene tallos subtetrágonos glabros (vs. tallos tetrágonos, escabrosos, con pelos retrorsos en los ángulos en *G. valerianoides*), hojas glabras, con nervios secundarios inconspicuos (vs. hojas escabrosas, con 2–3 pares de nervios basales y 2–3 pares suprabasales); semillas subcilíndricas, ápteras (vs. semillas complanadas, irregularmente aladas).

Distribución, hábitat y fenología. Sur de Brasil (São Paulo), en campos gramínicos de suelos con

afloramientos rocosos de 600–1000 m; florece y fructifica de octubre a julio.

Material representativo estudiado. BRASIL. **São Paulo:** Municipio de Itararé, Fazenda São Nicolau, 30 oct. 1993, *V. C. Souza 4431* (CTES, ESA); Pedreira, Cobastalco, 24°18'S, 49°12'W, 17 ago. 1994, *Barreto et al. 2976* (ESA, IAC).

29. *Galianthe thalictroides* (K. Schum.) E. L. Cabral, *Bol. Soc. Argent. Bot.* 27(3–4): 246. 1991. Basónimo: *Borreria thalictroides* K. Schum., *Fl. Bras.* 6: 71. 1888. *Spermacoce thalictroides* (K. Schum.) Kuntze, *Revis. Gen. Pl.* 3: 123. 1898. *Borreria verbenoides* var. *thalictroides* (K. Schum.) Porto & Miotto, *Bol. Inst. Centr. Bioci., Ser. Bot.* 35: 81. 1977. TIPO: Brasil. São Paulo, 1821, *A. Saint-Hilaire 1499* (neotipo, designado aquí, P!). Figura 10.

Sufrútice ramificado de 0.60–1.20 m alt., con xilopodio muy desarrollado, 3–5-caules primarios con ramas secundarias, opuestas, tallos subtetrágonos, glabros o papilosos. Hojas 8–25 × 0.7–2 mm, lineares o linear-lanceoladas, de margen revoluto, glabras o papilosas, con nervio central notable y nervios secundarios poco visibles; vaina estipular de 1–1.25 (–2.5) mm long., glabra o pubérula, con 1–5-lacinias de 0.2–2.5 mm. Inflorescencia terminal, sólo en los tallos primarios, pedúnculo de 6–10 cm. Hipanto turbinado, 1.5–1.7 mm, glabro; cáliz con lóbulos de 0.7–1.7 mm, triangulares, glabros; disco entero. Flor brevistila: corola 5.5–6.2 mm, de lóbulos más cortos que el tubo, interior con anillo de pelos moniliformes en el tubo y pelos dispersos en los lóbulos; estilo 3–3.2 mm; anteras 1–1.2 mm, filamentos 1.2–1.5 mm. Flor longistila: corola 3.7–5 mm, de lóbulos más largos que el tubo, interior con anillo de pelos moniliformes, delgados y densos en el tubo y pelos gruesos en los lóbulos; anteras subsésiles, 1.2–1.5 mm; estilo 3.7–5 mm. Cápsula 3–5 mm, glabra; semillas 2–3.5 mm, irregularmente aladas, comprimidas dorsiventralmente, cara ventral cubierta parcialmente por el estrofiolo.

Distribución, hábitat y fenología. Nordeste de Argentina (Misiones y Corrientes), Brasil (Paraná, Rio Grande do Sul, Santa Catarina, São Paulo), Paraguay oriental (Amambay, Caaguazú) y Uruguay, en campos altos, con suelo arenoso-rojizo, también en terrenos modificados, en borde de caminos, de 100–850 m; florece de noviembre a enero, fructifica de febrero a marzo.

Discusión. Los sintipos citados en el protologo del basónimo *Borreria thalictroides* han desaparecido en el herbario B, razón por la cual se elige un neotipo, de una colección clásica de Brasil, São Paulo, *A. Saint-Hilaire 1499* (P), que se encuentra completa y en buen estado de conservación.

Material representativo estudiado. ARGENTINA. **Corrientes:** Santo Tomé, Ayo. Chimiray, 23 nov. 1974, A. Krapovickas et al. 26151 (CTES). **Misiones:** Concepción, ruta 1, 5 km NW de Concepción, 18 dic. 1983, E. Cabral et al. 470 (CTES). BRASIL. **Paraná:** Guarapuava, 15 nov. 1957, G. Hatschbach 4288 (MBM). **Rio Grande do Sul:** Giruá, 18 abr. 1974, M. L. Porto et al. 1154 (ICN). **São Paulo:** Capão Bonito, oct. 1966, J. Mattos 13973 (SP). PARAGUAY. **Amambay:** Sierra de Amambay, in campis siccis Punta Porá, dic. 1908, E. Hassler et al. 9942 (G). **Caaguazú:** Dans les campos, nov. 1874, B. Balansa 1746 (G, P). URUGUAY. Banda oriental del Uruguay, 1816 a 1821, voyage d'Auguste de Saint-Hilaire 2653 (P).

30. *Galianthe valerianoides* (Cham. & Schltdl.) E. L. Cabral, Bol. Soc. Argent. Bot. 27(3-4): 246. 1991 [1992]. Basónimo: *Borreria valerianoides* Cham. & Schltdl., Linnaea 3: 335. 1828. *Spermacoce valerianoides* (Cham. & Schltdl.) Kuntze, Revis. Gen. Pl. 3: 123. 1898. TIPO: Brasil. Santa Catarina: 10 km S de São Joaquim, 5 ene. 1965, L. B. Smith et al. 14292 (neotipo, designado aquí, R!; isotipos, B!, HBR!, LP!, MO!). Figura 11.

Borreria luteovirens Standl., Publ. Field Mus. Nat. Hist., Bot. Ser. 8: 392. 1931. TIPO: Brasil. [Rio Grande do Sul:] Cachoeira, in palude, 12 Jan. 1902, G. O. Malme 1060 (holotipo, S!).

Sufrútice erecto, con xilopodio, de 0.8–2.5 m alt., tallo escabroso, rara vez glabro, ángulos muy marcados con pelos retrorsos; a veces ramas secundarias opuestas. Hojas 35–115 × 10–25 mm, lanceoladas u oblongo-lanceoladas, base obtusa o truncada, ápice agudo, escábridas, pelos más largos sobre los nervios en el envés; plegado-nervosas, con 2–3 pares de nervios secundarios basales y 2–3 pares de nervios suprabasales, ligeramente paralelos, vaina estipular pubescente de 3.5–5 mm, con 9–11 lacinias de 5–15 mm. Inflorescencia terminal, amplia, pedúnculos de 10–20 cm. Hipanto 2–2.5 mm, a veces piloso; cáliz con lóbulos de 2.5–4 mm, triangular-subulados; corola de 4.5–6.2 mm, con papilas densas sobre el margen y línea media de los lóbulos; disco bilobado. Flor brevistila: corola de lóbulos tan largos como el tubo, interior anillo ancho de pelos moniliformes en el tubo, hasta la base de los lóbulos; anteras 1.5–1.7 mm, filamentos 1.7–2.5 mm; estilo 2.5–3.5 mm. Flor longistila: corola, lóbulos más largos que el tubo, interior con anillo de pelos moniliformes, delgados, cortos, en el tubo y más gruesos y largos en los lóbulos; anteras subsésiles, 1.2–1.5 mm; estilo 4.2–6 mm. Cápsula 3.7–4.2 mm, subcilíndrica, glabra, a veces con pelos dispersos; semillas 2.5–3.5 mm, complanadas dorsiventralmente, cara ventral cubierta por estrofiolo membranáceo, cara dorsal finamente foveolada, desigualmente aladas.

Distribución, hábitat y fenología. Nordeste de Argentina (nordeste de Corrientes y Misiones), Paraguay oriental (Alto Paraná, Amambay, Caaguazú, Caazapá, Canindeyú, Central, Cordillera) y Brasil (Distrito Federal, Goiás, Mato Grosso, Minas Gerais, Paraná, Rio Grande do Sul, Santa Catarina, São Paulo), en pantanos, lugares bajos, esteros, bañados y en curso de arroyos; florece de octubre a enero, fructifica de febrero a julio.

Discusión. El ejemplar citado en el protologo del basónimo *Borreria valerianoides* ha desaparecido en el herbario B, razón por la cual se elige un neotipo, con duplicados, que fue coleccionado en el área donde esta especie es frecuente.

Observaciones. *Galianthe valerianoides* se puede reconocer fácilmente, por la altura de la planta hasta de 2.5 m, tallos tetragonos fistulosos, de hojas muy desarrolladas de base obtusa o truncada con nervios secundarios ± paralelos y amplia inflorescencia largamente pedunculada.

En Brasil tiene utilidades terapéuticas como ipecacuana (extraído de las etiquetas).

Nombre vulgar. “Sabuguerinho do campo” (Porto et al., 1977).

Material representativo estudiado. ARGENTINA. **Corrientes:** Ituzaingó, Playadito, 20 km W de Apóstoles, 4 Feb. 1982, A. Schinini et al. 21818 (CTES). **Misiones:** Loreto, 10 km del cruce de Ruta 12, camino a Oberá, 18 dic. 2000, E. Cabral 674 (CTES). BRASIL. **Distrito Federal:** Reserva Ecologica IBGE, 13 abr. 1983, B. Pereira 467 (IBGE). **Goiás:** Morrinhos, 4 ene. 1971, A. Rizzo et al. 5840 (UB). **Minas Gerais:** Alfredo Vasconcelos BR-3, 22 feb. 1967, A. P. Duarte 10397 (RB, UB). **Paraná:** Piraquara, 7 ene. 1909, P. Dusén 7790 (MO). **Rio Grande do Sul:** Mun. Santo Angelo, ene. 1932, C. Jürgens 460 (B). **São Paulo:** Bocaina, Serra da Bocaina, abr. 1972, J. H. Kirkbride 1745 (SP). **Santa Catarina:** Caçados, 7 jul. 1962, R. Klein 3544 (HBR). PARAGUAY. **Alto Paraná:** 7 km al sur de Villa Fortuna, ene. 1982, A. Fernández Casas et al. 5768 (G, MO, NY). **Amambay:** ago. 1907, E. Hassler 10702 (LIL). **Caaguazú:** Dans les prairies marecagensis, Mar. 1876, B. Balansa 1742 a (G, P). **Paraguai:** 24 feb. 1989, N. Battura 1157 (CTES, MBM). **Caazapá:** Tavai estero entrada al pueblo, 20 dic. 1988, F. Mereles 2371 (FCQ, MO). **Central:** Itá, ene. 1895, E. Hassler 1814 (CTES). **Cordillera:** Cordillere de Piribebuy, dans les prairies, abr. 1883, B. Balansa 4551 (P). **Canindeyú:** In palude Ipé-hú, Sierra Mbaracayú, oct. 1899, E. Hassler 5089 (F, G, NY, P).

II. *Galianthe* subg. *Galianthe* sect. *Laxae* E. L. Cabral, sect. nov. TIPO: *Galianthe laxa* (Cham. & Schltdl.) E. L. Cabral [– *Borreria laxa* Cham. & Schltdl.].

Frutex sufrutex sine xilopodio, thyrsi in ramis principalibus et lateralibus.

Frútice o sufrútice sin xilopodio, con raíces axonomorfas profundas, pluricaules, con ramas se-

cundarias desarrolladas, inflorescencias tirsiformes comprimidas, densas, excepcionalmente amplias, laxas, terminales o axilares en ramas primarias y secundarias; flores distilas, 4-meras; frutos capsulares; semillas con estrofiolo caduco o persistente, ápteras, raro alas inconspicuas. Comprende 9 especies que habitan en Bolivia (5 sp.), Brasil (4 sp.), Paraguay (4 sp.), Argentina (3 sp.) y Uruguay (1 sp.), en bordes de arroyos, de caminos, sotobosque de selvas o bosques, campos altos, rupestres, laderas de cerros de 0–3000 m. Figura 12 (A, B).

Se diferencia de la sección *Galianthe* porque la sección *Laxae* no tiene xilopodio, presenta tallo primario con numerosas ramas secundarias, desarrolladas y divididas, inflorescencias terminales y axilares en las ramas primarias y secundarias (vs. con xilopodio, 1–20-tallos primarios con inflorescencias terminales, si también tienen ramas secundarias, las inflorescencias se ubican sólo en tallos primarios, sección *Galianthe*).

Se eligió a *Galianthe laxa* como especie tipo, por ser su basónimo (*Borreria laxa*), una de las especies más antiguas y por su amplia distribución.

CLAVE PARA IDENTIFICAR LAS ESPECIES DE *GALIANTHE* SECT. *LAXAE*

1. Hojas de 1–4(–8) mm lat., con nervios secundarios inconspicuos o 2–5 pares visibles 2
1. Hojas de (2–)5–20(–35) mm lat., con (3–)4–6 pares de nervios secundarios visibles 5
- 2(1). Hojas con nervios secundarios inconspicuos; inflorescencias más o menos contestas 3
2. Hojas con 2–5 pares de nervios secundarios visibles; inflorescencias laxas 4
- 3(2). Hojas lineares o linear-lanceoladas, levemente pubescentes o con la haz glabra y el envés pubérulo, a veces escábridos en ambas caras; cáliz 2- raro 4-partido; corola externamente pubescente 3–3.7 mm long.; semillas aladas 33. *G. bispala*
3. Hojas lineares, glabras; cáliz 4-partido; corola micropapilada, 4–5 mm long.; semillas no aladas 36. *G. krausei*
- 4(2). Tallos pubérulos o levemente pubescentes; hojas pubérulas a pubescentes, con 3 pares de nervios secundarios; vaina estipular pubescente, con 5–9 (–10) lacinias de 5–9 mm long.; flor brevistila con pelos moniliformes en la superficie interior del tubo corolino 38. *G. sudyungensis*
4. Tallos glabros; hojas glabras, con 2–5 pares de nervios secundarios; vaina estipular pubérula a glabra, con 4–6 lacinias de 2–6 mm long.; flor brevistila, superficie interna con pelos moniliformes en el tubo y en los lóbulos . . . 32. *G. aurelii*
- 5(1). Hojas con notables papilas de base gruesa sobre los nervios del envés; corola de la flor brevistila y longistila con pelos moniliformes en la superficie interna del tubo 39. *G. verbenaoides*

5. Hojas sin papilas sobre los nervios del envés; corola de la flor brevistila y longistila con pelos moniliformes en el interior del tubo y pelos también en los lóbulos, éstos a veces ausentes en las flores brevistilas 6
- 6(5). Corola de las flores brevistilas y longistilas con pelos moniliformes en la superficie interna del tubo y en los lóbulos; hojas glabras; vaina estipular glabra, raro pubérula . 34. *G. chiquitosiana*
6. Corola de las flores brevistilas con pelos moniliformes, delgados y cortos en el tubo y en la flor longistila pelos en el tubo y en los lóbulos; hojas glabras, pubérulas o pubescentes; vaina estipular pubescente 7
- 7(6). Vaina estipular con lacinias de 3.5–17 mm long.; corola 3–6.5 mm long., con papilas muy desarrolladas en el dorso apical y márgenes de los lóbulos, más notables en el alabastro; sufrútice siempre erecto 35. *G. eupatorioides*
7. Vaina estipular con lacinias de 1.7–8 mm long.; corola 2–4 mm long., con papilas cortas sólo en el dorso apical de los lóbulos; sufrútice erecto o apoyante 8
- 8(7). Vaina estipular con lacinias glabras o pubérulas, rojizas; corola rosado-lilacina 31. *G. andersonii*
8. Vaina estipular con lacinias glabras no rojizas; corola blanca 37. *G. laxa*

31. *Galianthe andersonii* E. L. Cabral, Bonplandia (Corrientes) 10: 119–121. 2000. TIPO: Brasil. Minas Gerais: Serra do Espinhaço, 25 km by rd. NE of Diamantina, ca. 1.5 km from Jequití, 790–900 m, 12 abr. 1973, *W. R. Anderson 8717* (holotipo, UB!; isotipo, NY!).

Distribución, hábitat y fenología. Brasil (Minas Gerais), frecuente en chapadas con afloramientos rocosos o en campos rupestres de 700–1400 m, florece y fructifica de febrero a abril.

Observaciones. Esta especie es muy particular por sus tallos rojizos, por sus hojas secas discoloras, con la haz más oscuro y brillante, las lacinias de la vaina estipular 2–6 mm, rojizas; corola de 2–3.5 mm, con un ligero tinte rosa. Es afín a *Galianthe eupatorioides*, porque ambas son sufrútices ramificados cerca de 1 m alt., con forma y tamaño de hojas similares, pero esta última especie no presenta tallos rojizos, las lacinias de la vaina estipular son verdosas de 6–12 mm y la corola blanca de 2.5–5.5 mm.

Material representativo estudiado. BRASIL. Minas Gerais: Serra do Espinhaço, 10 km SW of Diamantina, 3 feb. 1972, *W. R. Anderson et al. 35231* (NY, UB).

32. *Galianthe aurelii* E. L. Cabral, Bonplandia (Corrientes) 7: 1. 1993. TIPO: Paraguay. Guairá: Colonia Independencia, Cerro Pelado, ene. 1967,

11

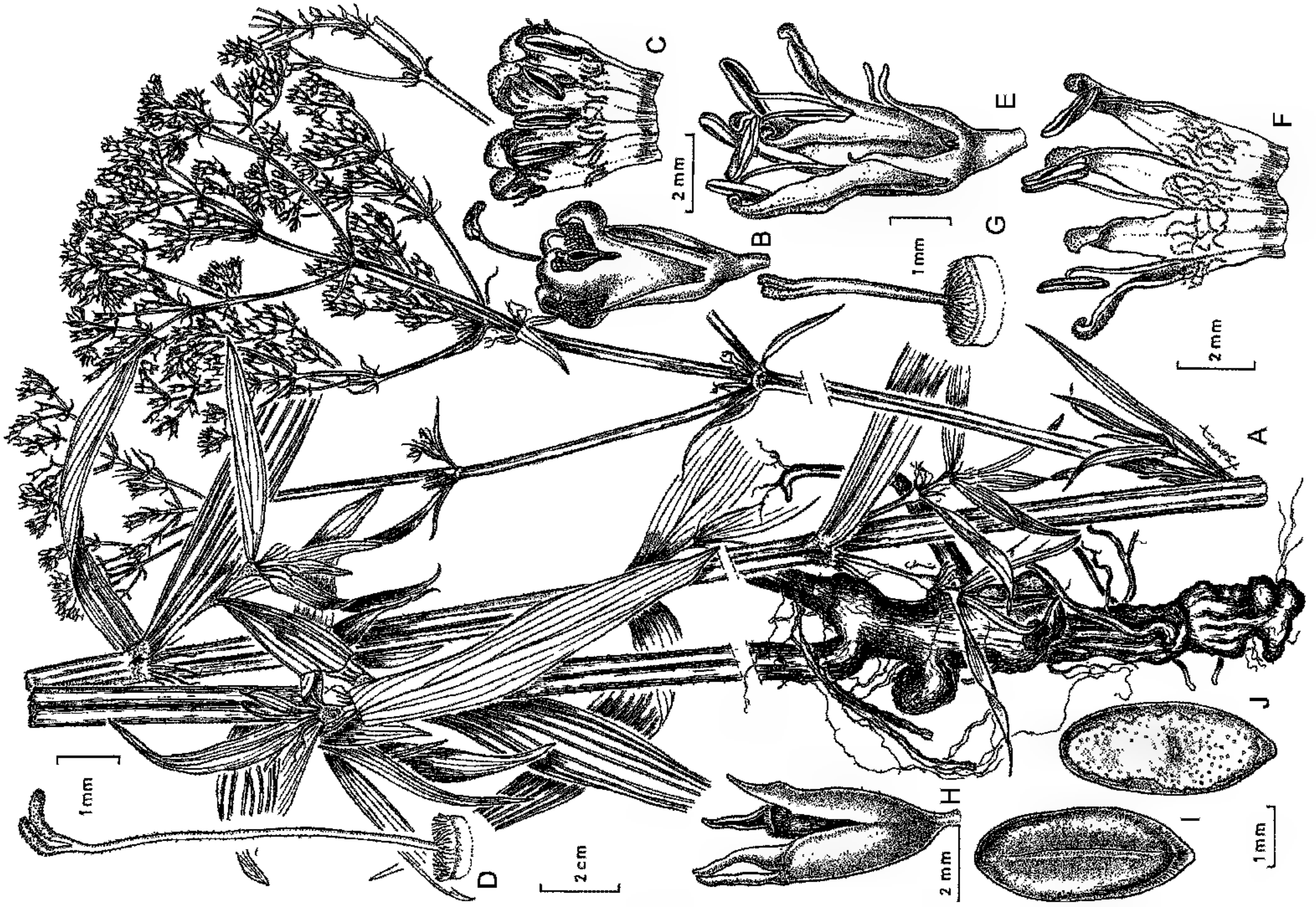

10

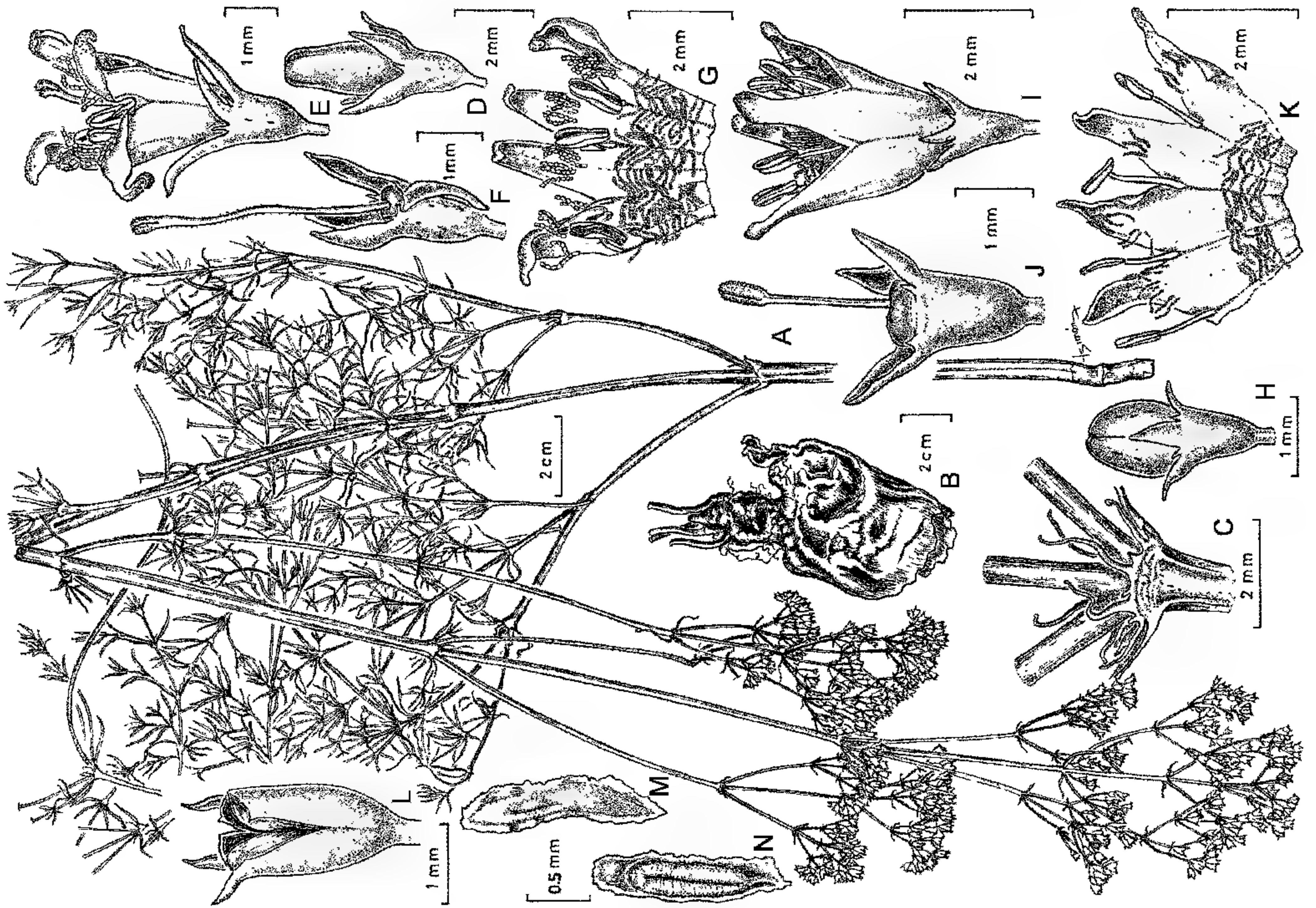



Figura 12. Distribución de especies de la sección *Laxa*. —A. Distribución de *Galianthe andersonii*, *G. aurelii*, *G. bispala*, *G. chiquitosiana*, *G. eupatorioides*. —B. Distribución de *G. krausei*, *G. laxa*, *G. sudyungensis*, *G. verbenoides*.

A. Schinini 2111 (holotipo, CTES!; isotipos, G!, LIL!, MO!).

Distribución, hábitat y fenología. Paraguay (Amambay, Central, Cordillera, Guairá, Paraguari), en laderas de cerros, entre rocas desnudas de 200–300 m; florece y fructifica de noviembre a julio.

Observaciones. Se reconoce por ser un sufrútice muy ramificado de 30–80 cm alt., de tallos glabros, con hojas membranáceas, linear-lanceoladas o lanceoladas de base decurrente formando pseudopetíolo, glabras, vaina estipular pubérula o glabra, con inflorescencias congestas, brevemente pedunculadas; disco entero, se asemeja a *Galianthe laxa* subsp. *paraguariensis* (Chodat) E. L. Cabral, por el hábito, forma y tamaño de las hojas, pero esta última especie tiene tallos pubérulos o pubescentes, hojas subcoriáceas con la haz pubérula y envés pubescente, vaina estipular pubescente y el disco nectarífero bipartido.

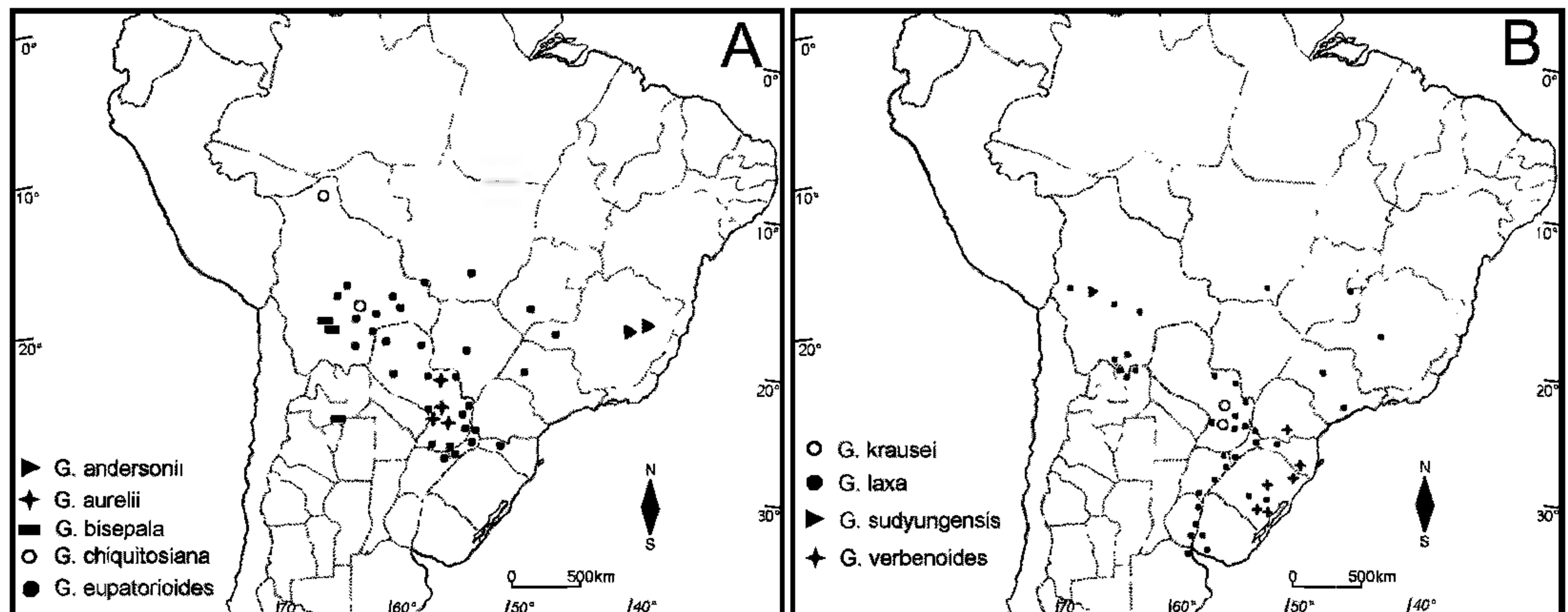
Material representativo estudiado. PARAGUAY. **Amambay:** cerca del Parque Nacional Cerro Corá, 9 feb. 1982, *J. Fernández Casas 6133* (G, MO). **Central:** Areguá, cerro de Areguá, 23 jul. 1972, *A. Schinini 5038* (MO). **Cordillera:** Piribebuy, Ygay-mi, 27 abr. 1983, *Soria 920* (CTES, FCQ). **Guairá:** Cerro de Villarrica, abr. 1924, *T. Rojas 4885* (SI). **Paraguari:** Isla Alta, Tebicuary Mi, 17 nov. 1978, *L. Bernardi 18756* (MO).

33. *Galianthe bispala* E. L. Cabral, *Bonplandia* (Corrientes) 7: 4. 1993. TIPO: Argentina. Salta: La Viña, Quebrada de las Conchas, entre la Salamanca y el Hongo, Ruta 68, Km 77–78, alt. 1300 m, 10 mar. 1990, *L. Novara & S. Bruno 9630* (holotipo, MCNS!; isotipos, B!, CORD!, CTES!).

Distribución, hábitat y fenología. Norte de Argentina (Salta), en un área muy restringida de 1200–1300 m y en Bolivia (Cochabamba y Potosí), en lugares áridos, ladera de cerros, borde de camino de (1200–)2500–2750 m; florece y fructifica de enero a abril.

Observaciones. Se la reconoce por ser un sufrútice muy ramificado de 0.4–1 m alt., tallos pubérulos, hojas lineares o linear-lanceoladas con indumento variado en haz y en envés, cáliz con 2 sépalos, raro 4 y semillas complanadas, ligeramente aladas. Por el hábito y las hojas angostas es afín a *Galianthe krausei* (Suess.) E. L. Cabral, pero esta especie tiene tallos y hojas glabras, el cáliz siempre tiene 4 sépalos y las semillas no son aladas.

En las observaciones de las etiquetas de los ejemplares de Bolivia, se menciona que localmente es usada como forrajera.

Figura 10. *Galianthe thalictroides*. —A. Planta. —B. Xilopodio. —C. Vaina estipular con lacinias. D–G. Flor longistila. —D. Alabastro. —E. Flor. —F. Hipanto, cáliz, estilo y estigma. —G. Interior de la corola desplegada. H–K. Flor brevistila. —H. Alabastro. —I. Flor. —J. Hipanto, cáliz, disco, estilo y estigma. —K. Interior de la corola desplegada. —L. Fruto. M–N. Semilla. —M. Cara dorsal. —N. Cara ventral. (A–G, *Schinini 23467*; H–N, *Krapovickas 21139*.)

Figura 11. *Galianthe valerianoides*. —A. Planta con xilopodio. B–D. Flor longistila. —B. Flor. —C. Interior de la corola desplegada. —D. Disco, cáliz, estilo y estigma. E–G. Flor brevistila. —E. Flor. —F. Interior de la corola desplegada. —G. Disco, cáliz, estilo y estigma. —H. Fruto. I–J. Semilla. —I. Cara dorsal. —J. Cara ventral. (A–D, *Tressens 1885*; E–J, *Schinini 21818*.)

Nombre vulgar. En Bolivia "tholita" (extraído de observaciones de etiquetas), quizás por ser de porte similar, pero más reducido que las "tholas", usadas como combustible (*Lepidophyllum quadrangulare* (Meyen) Benth. & Hook. f. y *Baccharis tola* Phil.).

Material representativo estudiado. ARGENTINA. **Salta:** Guachipas, Alemania, 14 abr. 1963, A. Correa 521 (MCNS). BOLIVIA. **Cochabamba:** On the ascent from the Río Mizque going N toward Totora from Aiquile, 2600 m, 20 Mar. 1994, J. R. Wood 8137 (CTES, MO). **Potosí:** José M. Linares Lizarazu, Jatun Palmar, 2750 m, 167 km al E de la ciudad, bajando el camino hacia la quebrada, 5 abr. 1993, G. Torrico et al. 335 (CTES, LPB).

34. *Galianthe chiquitosiana* E. L. Cabral, *Brittonia* 57(2): 142–145. 2005. TIPO: Bolivia. Santa Cruz: Chiquitos Prov., S slope of Serranía de Santiago, 5–10 km E of town of Santiago de Chiquitos, 18°23'S, 59°30'W, 20 July 1983, D. C. Daly et al. 2175 (holotipo, USZ!; isotipos, CTES!, MO!, NY!, SI!).

Distribución, hábitat y fenología. En Bolivia (Santa Cruz), en campos, sometidos a quemadas frecuentes, también en laderas rocosas y campos rupestres, de 230–900 m; florece y fructifica de noviembre a julio.

Observaciones. Se reconoce por ser un arbusto muy ramificado cerca 1 m alt., tallos glabros de corteza oscura, con hojas elíptico-lanceoladas, subcoriáceas, glabras, plegado-nervadas, 2–3 pares de nervios secundarios basales, adheridos al nervio central del que se separan gradualmente hacia el ápice; y el interior de la corola con pelos moniliformes en los lóbulos y en la mitad superior del tubo. Por su hábito es similar a *Galianthe verbenoides*, pero esta especie tiene las hojas discoloras, pubescentes o escabriúsculas, con visibles papilas aculeadas sobre los nervios del envés, 3 ó 6 pares de nervios secundarios subopuestos, en arcos convergentes hacia el ápice y el interior de la corola tiene un solo anillo de pelos moniliformes en el tubo.

Material representativo estudiado. BOLIVIA. **Santa Cruz:** Chiquitos, Santiago de Chiquitos, campo rupestre, 18°40'S, 59°15'W, 13 nov. 1997, F. Mamani et al. 1254 (CTES, MO, SI, USZ).

35. *Galianthe eupatorioides* (Cham. & Schltld.) E. L. Cabral, *Bol. Soc. Argent. Bot.* 27(3–4): 242. 1991 [1992]. Basónimo: *Borreria eupatorioides* Cham. & Schltld., *Linnaea* 3: 327. 1828. *Spermacoce eupatorioides* (Cham. & Schltld.) Kuntze, *Revis. Gen. Pl.* 3(3): 123. 1898. TIPO: Brasil. Minas Gerais: Campina Verde, 26 mayo 1943, A. Macedo 67 (neotipo, designado por Cabral [2003: 396], SP!; isotipo, MO!).

Distribución, hábitat y fenología. Nordeste de Argentina (nordeste de Corrientes y Misiones), Bolivia (Chuquisaca, Santa Cruz), Paraguay (Alto Paraguay, Alto Paraná, Amambay, Boquerón, Caaguazú, Central, Concepción, Guairá, Itapúa, Misiones, Nueva Asunción), sur y centro de Brasil (Goiás, Mato Grosso, Mato Grosso do Sul, Minas Gerais, Paraná, Santa Catarina, São Paulo); frecuente en suelos arenosos, lateríticos, bordes de camino, selvas y bosques submontanos, en campos cerrados, y como fijadora o estabilizadora de dunas, de 50–1600 m; florece de agosto a marzo, fructifica de marzo a julio.

Observaciones. Esta especie se reconoce por ser un sufrutice muy ramificado de 0.5–2 m alt., con inflorescencias = laxas, amplias, las semillas tienen surco amplio en la cara ventral, cubierto sólo en la línea media por el estrofiolo caduco. La pubescencia de la planta, tamaño, forma de las hojas y longitud de las lacinias, son caracteres variables de menor valor taxonómico. Se observaron que dichos caracteres variaban en la misma planta, en población de Bolivia y de Paraguay, mientras que los de Argentina y Brasil se mantienen constantes.

Para la flora de Argentina el material mencionado como *Borreria eupatorioides* por Bacigalupo (1974) corresponde a *Galianthe centranthoides*. Del material de *G. eupatorioides* de la flora boliviana, analizado por Kuntze (1898), una parte identificó como *Spermacoce eupatorioides* [– *G. eupatorioides*], mientras que el resto confundió con *B. angustifolia* Cham. & Schltld. [– *G. angustifolia*]. Cuando transfirió a *Spermacoce* creó un nuevo nombre, *S. chamissonis* Kuntze. De manera que esa cita para Bolivia corresponde a material de *G. eupatorioides*.

Material representativo estudiado. ARGENTINA. **Corrientes:** Ituzaingó, 5 km NE de Ituzaingó, camino a Apipé, 10 abr. 1978, O. Ahumada et al. 2458 (CTES, F, G, MBM, MO). **Misiones:** San Ignacio, 18 dic. 1981, E. Cabral et al. 180 (CTES, G, MBM, UB). BOLIVIA. **Chuquisaca:** Pcia. L. Calvo, 20°34'S, 63°08'W, El Salvador, 7 abr. 1993, C. Saravia et al. 11457 (CTES). **Santa Cruz:** Yapacani, jun. 1892, O. Kuntze s.n. (NY). BRASIL. **Goiás:** Triangulo Mineiro, 26 mayo 1943, A. Macedo 67 (MO). **São Paulo:** São José do Rio Preto, ene. 1963, G. de Marinis 90 (SP). **Mato Grosso:** Serra do Aguapey, 4 mar. 1977, J. Kirkbride et al. 3056 (MO). **Mato Grosso do Sul:** Selviria, 1 feb. 1991, O. Tiritan et al. 451 (UB). **Paraná:** Foz de Iguazú, 14 mar. 1976, G. Davidse et al. 11294 (MO, SP). **Santa Catarina:** Morro das Pedras, 3 mar. 1962, S. Sehnem 8003 (B). PARAGUAY. 1890, T. Morong 610 (MO). **Alto Paraguay:** Tyto. Gabino Mendoza-Gral. Garay, 31 abr. 1995, R. Degen et al. 3301 (CTES, FCQ). **Alto Paraná:** Ea. Santa Elena, 12 km NE de Hernandarias, 5 jul. 1991, A. Schinini et al. 27404 (CTES, G, MBM, MO). **Amambay:** 13–15 km S de ruta 5, Cerro Corá, Cnia. Picada Lorito, 11 dic. 1997, A. Schinini et al. 33727 (CTES, G, GH, MO, SI). **Boquerón:** Delegación de Nueva Asunción, 18 nov. 1992,

R. Degen et al. 2897 (FCQ). **Caaguazú:** 20 km de Caaguazú hacia Yhú, 6 abr. 1965, *O. Brescia et al.* 5035 (MVFA). **Central:** Betw. Villarica & Escoba, 3 ene. 1889, *T. Morong* 610 (MO, NY, US). **Concepción:** Paso Barreto, 63 km NE de Concepción, 19 abr. 1995, *A. Schinini et al.* 29353 (CTES). **Guairá:** Reserve Tajijupi, 6 km de Hernandarias, 7 ene. 1985, *H. Stutz* 2144 (G). **Itapúa:** 16 km N de Cnel. Bogado, 56°10'W, 27°7'S, 21 mar. 1993, *A. Schinini et al.* 27642 (ASU, BAB, CHR, CTES, F, G, GH, LIL, MBM, MICH, NY, TEX, US, WIS). **Misiones:** Ea. La Soledad, 1 feb. 1955, *T. Pedersen* 3211 (CTES). **Nueva Asunción:** Gral. E. Garay, 7 ago. 1992, *F. Mereles et al.* 4572 (FCQ).

36. *Galianthe krausei* (Suess.) E. L. Cabral, Bol. Soc. Argent. Bot. 27(3-4): 244. 1991 [1992]. Basónimo: *Borreria krausei* Suess., Mitt. Bot. Staatssamml. München 1: 19. 1950. TIPO: Paraguay. Cordillera: cerros de Tobatí, Cerro Penitente, in saxibus aridis, Jan., *Fiebrig* 755 (holotipo, G!; isotipos, F!, K!, P!). Figura 13.

Borreria corymbosa f. *microphylla* Chodat & Hassl., Bull. Herb. Boissier, sér. 2, 4: 187. 1904. TIPO: Paraguay. Cordillera: In colle Tobaty, Mar., *E. Hassler* 4022 (holotipo, G!; isotipos, BM!, F!, G!, K!, P!).

Sufrútice sin xilopodio, muy ramificado, de 0.50–1 m alt., tallos glabros. Hojas 7–35 × 1–3 mm, pseudoverticiladas, lineares, de margen revoluto, glabras, nervios secundarios inconspicuos; vaina estipular de 1–2 mm, glabra o pubérula con 2–5 laciniadas de 0.7–1.7 mm. Inflorescencias tirsoideas, congestas, paucifloras. Hipanto 0.7–1.2 mm, turbinado, papiloso; cáliz con lóbulos triangular-subulados, 0.7–1 mm, glabros, disco entero. Flor brevistila: corola 4.2–5 mm, lóbulos más cortos que el tubo, superficie interna con pelos moniliformes en el tubo, hasta la base de los lóbulos; anteras 1–1.2 mm, filamentos 0.7–1 mm; estilo 2.2–2.5 mm. Flor longistila: corola 4–4.7 mm, lóbulos iguales o más cortos que el tubo, superficie interna con pelos moniliformes, más gruesos en los lóbulos, cortos y finos en el tubo; anteras subsésiles, 1–1.3 mm; estilo 4–4.5 mm. Cápsula 2.5–3 mm, glabra; semillas 2–2.5 mm, plano-convexas, escrobiculadas, de cara ventral con un surco profundo y amplio alrededor del estrofiolo caduco.

Distribución, hábitat y fenología. Paraguay (Cordillera y Paraguari), en Cordillera de Altos, en campos con suelos pedregosos de 200–350 m; florece de noviembre a febrero, fructifica de marzo a octubre.

Observación. *Borreria saxicola* K. Krause (Krause, 1908) [non *Borreria saxicola* K. Schum. (Schumann, 1901)] es nom. illeg.

Material representativo estudiado. PARAGUAY. **Paraguari:** Parque Nacional Ybycuí, 15 Sep. 1988, *E. Zardini* 7281 (CTES, MO, PY).

37. *Galianthe laxa* (Cham. & Schtdl.) E. L. Cabral, Bol. Soc. Argent. Bot. 27: 244. 1991. Basónimo: *Borreria laxa* Cham. & Schtdl., Linnaea 3(4): 337. 1828. *Spermacoce laxa* (Cham. & Schtdl.) Kuntze, Revis. Gen. Pl. 3(3): 123. 1898. TIPO: In Brasilia meridionali lectam transmisit, *Sellow* s.n. (holotipo, B!, foto F 880!).

Sufrútice erecto, a veces apoyante de 0.5–1.5 m alt.; tallos glabros, pubérulos, pubescentes, de ángulos marcados, papilosos o con pelos retrorsos. Hojas 2–6(–10) × (0.2–)0.6–2(–3) cm, pseudoverticiladas, elípticas u oval-elípticas, discoloras, ápice agudo o atenuado, base aguda en pseudopetíolo, glabras o con pelos dispersos en la haz, pubescentes en el envés, o pubescentes en ambas caras, con 4–6 pares de nervios secundarios, surcados en la haz y prominentes en el envés; vaina estipular 1.5–2.5 mm, pubescente, con 5–12 laciniadas de 3–8 mm. Inflorescencias tirsoideas laxas, raro comprimidas. Hipanto turbinado, 1–1.7 mm, glabro, pubérulo o pubescente; cáliz 4-partido, lóbulos 1–1.7 mm, glabros con margen piloso; corola con papilas desarrolladas en el extremo superior de los lóbulos, a veces pubérula; disco entero. Flor brevistila: corola 3–4 mm, lóbulos y tubo aproximadamente de la misma longitud, interior con pelos moniliformes, delgados en el tubo; anteras 0.7–1 mm, filamentos ca. 1 mm, estilo 1.5–2 mm. Flor longistila: corola 2.7–4 mm, lóbulos mayores o iguales que el tubo, interior con un anillo de pelos moniliformes, finos y cortos en la mitad del tubo y sendas bandas de pelos gruesos en la mitad de los lóbulos; anteras subsésiles 0.7–1 mm; estilo 3.7–5 mm. Cápsula 1.7–3 mm, turbিনada, brevemente pedicelada, glabra o con pubescencia rala; semilla 1.7–2.5 mm, elipsoide, foveolada, castaño-clara, con surco amplio y profundo en la cara ventral, estrofiolo grueso, irregular, fácilmente caedizo, a veces persistente sobre el tabique interocular.

CLAVE PARA IDENTIFICAR LAS SUBESPECIES DE *GALIANTHE LAXA*

- 1a. Hojas elípticas, oval-elípticas, lanceoladas u oval-lanceoladas de 6–30 mm lat., glabras, pubescentes o con pelos dispersos en el margen, pubescentes en el envés y levemente pubescentes en la haz, membranáceas; tallos erectos y a veces apoyantes; inflorescencia laxa de 8–50 cm long.; varios hábitats, 0–3000 m 37a. *G. laxa* subsp. *laxa*
- 1b. Hojas linear-lanceoladas de 2–7 mm lat., haz pubérula, envés pubescente con pelos más densos sobre los nervios, subcoriáceas; tallos siempre erectos; inflorescencia + congesta de 4–8 cm long.; campos rupestres, 100–300 m
. 37b. *G. laxa* subsp. *paraguariensis*

14

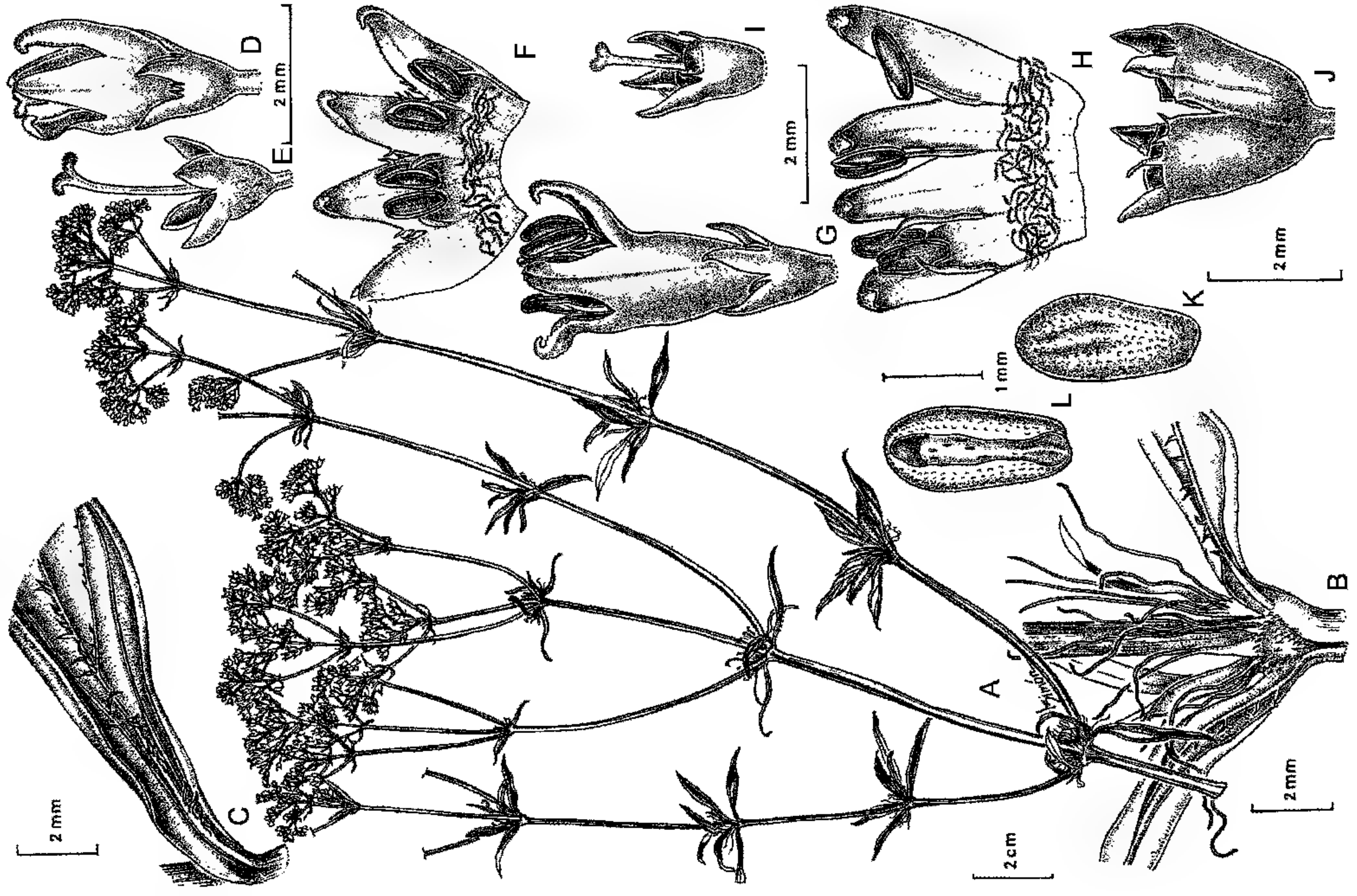

13

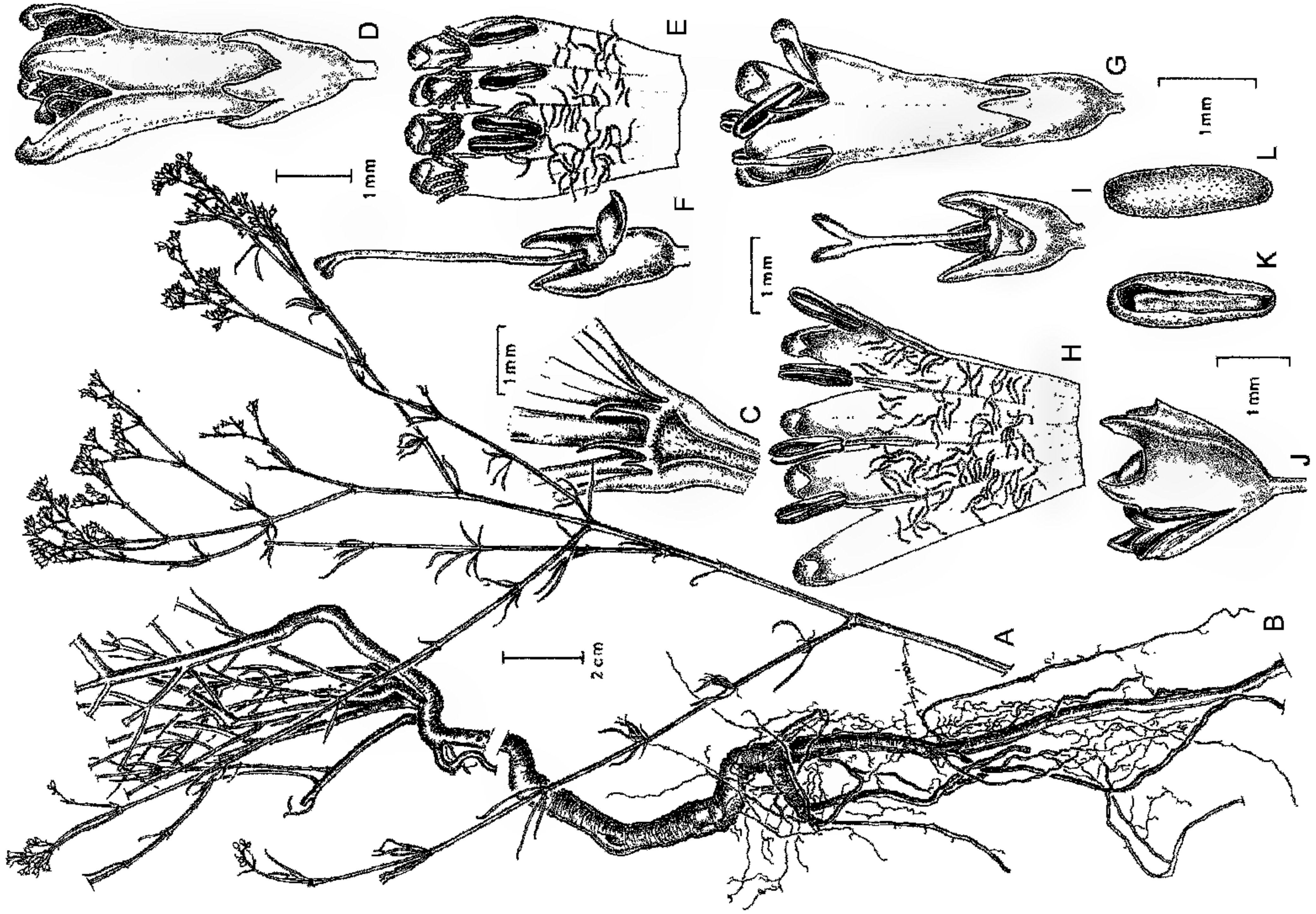

37a. *Galianthe laxa* (Cham. & Schltdl.) E. L. Cabral subsp. *laxa*.

Borreria cristata S. Moore, J. Bot. 42: 101. 1904. Syn. nov. *Galianthe cristata* (S. Moore) E. L. Cabral, Bol. Soc. Argent. Bot. 27(3-4): 241. 1991 [1992]. TIPO: Brasil. Mato Grosso: Santa Ana da Chapada, 28 jun. 1902, A. Robert 368 (holotipo, BM!; isotipo, K!).
Borreria mitreoloides Standl., Publ. Field Columbian Mus., Bot. Ser. 8(5): 395. 1931. Syn. nov. TIPO: Brasil. Mato Grosso: Serra da Chapada, in silva, 2 jun. 1903, G. O. Malme s.n. (holotipo, S!).

Distribución, hábitat y fenología. Norte y centro de Argentina (Buenos Aires, Corrientes, Entre Ríos, Misiones, Salta), Bolivia (Chuquisaca, La Paz, Santa Cruz, Tarija), centro y sur de Brasil (Goiás, Mato Grosso, Mato Grosso do Sul, Minas Gerais, Paraná, Rio Grande do Sul, Santa Catarina, São Paulo), Paraguay (Alto Paraná, Amambay, Caazapá, Canindeyú, Central, Concepción, Guairá, San Pedro) y Uruguay (Colonia, Montevideo, San José, Soriano), en el sudeste del área, en campos bajos, a orillas de arroyos y ríos, en lugares abiertos o en el interior de bosques o selvas a 0–3000 m, cambiando hacia el norte, en Paraguay oriental, en campos rupestres de 100–300 m, hacia el noroeste en Salta, Argentina, en hábitat entre 500–600 m, hasta llegar alturas de 1500 m Bolivia. Es la especie del subg. *Galianthe* más austral, su área de distribución llega hasta el delta del Paraná, Buenos Aires; florece de noviembre a febrero, fructifica de marzo a agosto.

Observaciones. El material citado para la Argentina por Grisebach (1879) como *Galianthe verbenoides* Griseb. corresponde a *G. laxa* subsp. *laxa*.

En medicina popular usada como diurético y contra afecciones del hígado (Bacigalupo, 1974).

Nombre vulgar. En Argentina “rallada” (de la Peña & Pensiero, 2004).

Material representativo estudiado. ARGENTINA. **Buenos Aires:** Isla Martín García, 21 jul. 1946, R. Palacios 73 (CTES). **Corrientes:** Ituzaingó, 12 km NW de Playadito, ruta 39, 14 nov. 1981, R. Carnevali 5122 (CTES). **Entre Ríos:** Federación, 20 dic. 1946, T. Meyer 11024 (CTES). **Misiones:** San Pedro, cercanías del Piray-guazú, 17 jul. 1949, E. Schwindt 1993 (CTES). **Salta:** Depto. Iruya,

Sausalito, 15 abr. 1947, S. Pierotti 6606 (LIL). BOLIVIA. Reis, Jun. 1886, H. Rusby 2107 (K, NY, P). **Chuquisaca:** 27 feb. 1904, K. Fiebrig 2729 (K). **La Paz:** Millugnaya in Nord-Yungas, dic. 1917, O. Buchtien 765 (MO, NY). **Santa Cruz:** estancia Quesada, límite de frontera, 13 mar. 1989, F. Mereles et al. 2872 (CTES, FCQ, G). **Tarija:** Arce, 22°12'S, 64°37'W, 27 abr. 1983, J. Solomon 10159 (MO). BRASIL. **Goiás:** Serra Dourada, ca. 15 km S of Goiás Velho, 10 mayo 1973, W. R. Anderson 10010 (UB). **Mato Grosso:** Mun. Pedra Preta, Rod. BR-364, Serra da Petrovina, 16 mayo 1995, G. Hatschbach et al. 62827 (CTES, MBM). **Mato Grosso do Sul:** Mun. Corumbá, Sub-região da Nhecolândia, 25 jul. 1985, A. Pott 2033 (CPAP, CTES). **Minas Gerais:** Mun. Santa Rita do Sapucaí, Vintém de Baixo, 19 feb. 1996, O. S. Ribas 1288 (CTES, MBM). **Paraná:** 23 nov. 1972, L. Dombrowski et al. 4309 (US). **Rio Grande do Sul:** 1833, Ch. Gaudichaud 1114 (P). **Santa Catarina:** São Louis Guaraciaba, 3 ene. 1964, R. Reitz et al. 16955 (HBR). **São Paulo:** Mun. Porto Ferreira, Reserva Estadual de Porto Ferreira, 30 jun. 1981, J. Bertoni 18652 (CTES, UEC). PARAGUAY. **Alto Paraná:** 1910, K. Fiebrig 124 (G). **Amambay:** Rio Apa, 1908, K. Fiebrig 4323 (B, G, P). **Caaguazú:** Yhú, 12 dic. 1982, A. Schinini 22915 (CTES). **Caazapá:** Tavai, 5 km del destacamento, 26°10'S, 55°17'W, 15 mayo 1989, N. Soria 3857 (CTES, FCQ). **Canindeyú:** 46 km S de Katueté, 18 dic. 1982, A. Schinini 23198 (CTES, G). **Central:** Lacus Ypacaray, 1913, E. Hassler 11733A (G [p.p.], MO). **Concepción:** Ruta 3, 45 km S de Ybyyau, 17 mayo 1974, A. Schinini 9075 (CTES, MBM, SI). **Guairá:** Villarica, P. Jørgensen 3706 (BAB, NY). URUGUAY. **Colonia:** Carmelo, monte costero del Río de la Plata, 7–9 mar. 1964, B. Arrillaga et al. 1898 (SI). **Montevideo:** M. Fruchard s.n. (B).

37b. *Galianthe laxa* subsp. *paraguariensis* (Chodat & Hassl.) E. L. Cabral, Candollea 58(1-2): 394. 2003. Basónimo: *Borreria paraguariensis* Chodat & Hassl., Bull. Herb. Boissier, sér. 2, 4: 186. 1904. *Borreria laxa* Cham. & Schltdl. var. *vestita* L. B. Sm. & Downs, J. Washington Acad. Sci. 48: 284. 1958. *Galianthe paraguariensis* (Chodat & Hassl.) E. L. Cabral, Bol. Soc. Argent. Bot. 27(3-4): 245. 1991 [1992]. TIPO: Paraguay, Cordillera: In dumetis Cordillera de Altos, Sep., E. Hassler 3263 (lectotipo, designado por Cabral [1991: 245], G!; isotipo, P!).

Borreria paraguariensis f. *puberula* Chodat & Hassl., Bull. Herb. Boissier, sér. 2, 4: 186. 1904. TIPO: Paraguay. Amambay: In glareosis collium prope Paraguay, Dec., E. Hassler 6508 (holotipo, G!; isotipo, G!).

Borreria paraguariensis f. *latifolia* Chodat & Hassl., Bull. Herb. Boissier, sér. 2, 4: 186. 1904. TIPO: Paraguay.

←

Figura 13. *Galianthe krausei*. —A. Rama con inflorescencia. —B. Raíz axonomorfa. —C. Vaina estipular con laciniás. D–F. Flor longistila. —D. Flor. —E. Interior de la corola desplegada. —F. Hipanto, cáliz, estilo y estigma. G–I. Flor brevistila. —G. Flor. —H. Interior de la corola desplegada. —I. Hipanto, cáliz, estilo y estigma. —J. Fruto. K–L. Semilla. —K. Cara ventral. —L. Cara dorsal. (A–H, Schinini 23956; I–L, Degen 480.)

Figura 14. *Galianthe verbenoides*. —A. Rama. —B. Vaina estipular con laciniás. —C. Base foliar y parte del hipófilo. D–F. Flor longistila. —D. Flor. —E. Hipanto, cáliz, estilo y estigma. —F. Interior de la corola desplegada. G–I. Flor brevistila. —G. Flor. —H. Interior de la corola desplegada. —I. Hipanto, cáliz, estilo y estigma. —J. Fruto. K–L. Semilla. —K. Cara dorsal. —L. Cara ventral. (A–I, Bueno 3642; J–L, Hagelund 13744.)

Amambay: ad marginem silvae prope Bellavista, Apa, Nov., *E. Hassler 7999* (holotipo, G!; isotipos, G!, P!).

Distribución, hábitat y fenología. En Paraguay (Amambay, Central, Paraguari y Cordillera), en campos rupestres de 100–300 m; florece de septiembre a mayo, fructifica de junio a agosto.

Material representativo estudiado. PARAGUAY. **Central:** In regione lacus Ypacaray, mayo 1913, *E. Hassler 11733* (BAF, G [p.p.], MO). **Cordillera:** betw. Emboscada and Nueva Colombia, 25 June 1992, *E. Zardini et al. 32302* (AS, CTES, MO). **Paraguari:** National Park Ybycuí, 22 June 1991, *E. Zardini et al. 27863* (CTES, MO, PY).

38. *Galianthe sudyungensis* E. L. Cabral, *Brittonia* 57(2): 145. 2005. TIPO: Bolivia. La Paz: Prov. Sud Yungas, Río Jucumarini, 16°37'S, 67°27'W, 14 abr. 1990, *M. Lewis 37202* (holotipo, LPB!; isotipos, CTES!, P!).

Distribución, hábitat y fenología. Bolivia (La Paz, Sud Yungas), en campos altos de 985–1500 m, florece de enero a abril y fructifica de abril a julio.

Observaciones. *Galianthe sudyungensis* se caracteriza por ser un sufrútice muy ramificado, de 30–50 cm alt., de tallos tetragonos, rojizos, con hojas pseudoverticiladas, linear-lanceoladas a lanceoladas, discoloras; vaina estipular pubescente, con 5–9(–10) lacinias, glabras; inflorescencias comprimidas, las semillas subcomplanadas, finamente aladas en el ápice y con el estrofiolo caduco en la cara ventral. *Galianthe sudyungensis* es muy similar a *G. aurelii*, ambas especies son muy ramificadas y tienen hojas pseudoverticiladas, pero difieren por los siguientes caracteres: *G. sudyungensis* es diferenciada por el tallo y las hojas pubérulas a pubescentes (vs. glabros en *G. aurelii*), lacinias estipulares rojizas de 5–9 mm (vs. verdosas de 2–6 mm), interior de la corola con pelos solo en el tubo (vs. pelos en el tubo y en los lóbulos).

Material representativo estudiado. BOLIVIA. **Sud Yungas:** ridge of Pasto Grande, 16°37'S, 67°29'W, 12 abr. 1990, *M. Lewis 37173* (CTES, LPB, MO).

39. *Galianthe verbenoides* (Cham. & Schltdl.) Griseb., *Symb. Fl. Argent.* 24: 157. 1879. Basónimo: *Borreria verbenoides* f. *prima* Cham. & Schltdl., *Linnaea* 3(4): 333. 1828. *Spermacoce verbenoides* (Cham. & Schltdl.) Niederl., *Bol. Mens. Mus. Prod. Argent.* 3(31): 306. 1890. *Spermacoce verbenoides* (Cham. & Schltdl.) Kuntze, *Revis. Gen. Pl.* 3: 123. 1898, nom. superfl. *Borreria verbenoides* Cham. & Schltdl. var. *eupatorioides* (Cham. & Schltdl.) L. B. Sm. & Downs, *J. Wash. Acad. Sci.* 48: 284. 1958. TIPO: Brasil. In Brasilia meridionali legit *Sellow* (lectotipo, designado aquí, LE!). Figura 14.

Sufrútice ramificado, de 0.6–1 m alt., con ramas laterales desarrolladas, opuestas, tallos tetragonos a subcilíndricos, glabros a veces con pelos o papilas aculeadas, mameliformes, con frecuencia cerca de las estípulas. Hojas 15–120 × 3–17 mm, oblongo-elípticas, de ápice agudo a atenuado, base aguda prolongada en pseudopecíolo, discoloras, levemente pubescentes o escabriúsculas, con papilas aculeadas, de base gruesa sobre los nervios del envés, más notables en el nervio medio, margen revoluto, escabriúsculo, con 3–6 pares de nervios secundarios en relieve en el envés, levemente surcadas en la haz; vaina estipular de 2–4 mm, pubérula o pubescente con 10–11 lacinias, de 7–12 mm. Hipanto 1–1.5 mm, turbinado, glabro; cáliz de lóbulos 1–1.5 mm, triangular-subulados, glabros; corola con papilas densas hacia el ápice de los lóbulos; disco entero. Flor brevistila: corola (2.5–)4.5–4.7 mm, lóbulos iguales o más cortos que el tubo, superficie interna con un anillo de pelos moniliformes en la mitad del tubo; anteras 1–1.3 mm, filamentos ca. 1.5 mm; estilo 1.5–2 mm. Flor longistila: corola 3–3.2 mm, lóbulos iguales o más largos que el tubo, superficie interna con pelos moniliformes cortos, en la mitad del tubo y algunos pocos en la base de los lóbulos, anteras subsésiles, 0.7–1 mm; estilo 2.5–3.7(–4.2) mm. Cápsula 1.7–2 mm, subglobosa, glabra; semillas 1.5–1.7 mm, subcilíndricas, escrobiculadas, con un surco en la cara ventral alrededor del estrofiolo persistente.

Distribución, hábitat y fenología. Sur de Brasil (Paraná, Rio Grande do Sul, Santa Catarina), frecuente en bordes de camino, de arroyos y en campos altos de 0–3000 m; florece y fructifica de noviembre a abril.

Observación. Smith y Downs (1958) proponen para el basónimo *Borreria verbenoides* la variedad *eupatorioides* (Cham. & Schltdl.) L. B. Sm. & Downs, pero en este trabajo se trata cada una de las especies: *B. verbenoides* (– *Galianthe verbenoides*) y *B. eupatorioides* (– *G. eupatorioides*) como entidades distintas, según la clave presentada aquí. El material estudiado por esos autores e identificado como *B. verbenoides* var. *eupatorioides* fue consultado en el Herbario HBR y se comprobó que corresponde a *G. centranthoides* (Cham. & Schltdl.) E. L. Cabral.

Este concepto fue seguido por Delprete et al. (2004), en la Flora de Santa Catarina, Brasil, y además agregan como sinónimos a *Galianthe valerianoides* y *G. chodatiana* (secc. *Galianthe*), que aquí son tratados como especies diferentes.

Por considerar que el original de *Galianthe verbenoides* ha desaparecido en el herbario B (foto F 890), se elige como lectotipo, el ejemplar duplicado

del herbario LE y además está en buen estado de conservación.

Material representativo estudiado. BRASIL. **Paraná:** Lapa, 5 abr. 1960, R. Braga et al. 266 (NY). **Rio Grande do Sul:** 1833, C. Gaudichaud 1118 (P); Arroyo dos Ratos, 30 ene. 1985, E. Cabral 486 (CTES). **Santa Catarina:** Irani, 27 feb. 1964, Klein 4719a (B).

Literatura Citada

- Bacigalupo, N. M. 1974. Rubiaceae. En A. Burkart (editor), Flora Ilustrada de Entre Ríos. Colecc. Ci. Inst. Nac. Tecnol. Agropecu. 6(6): 17–27.
- Cabral, E. L. 1981. Novedades en el género *Borreria* (Rubiaceae), para la flora de Corrientes. Bonplandia 5(16): 143–148.
- . 1985. Valor taxonómico del polen en las especies argentinas del género *Borreria* (Rubiaceae). Bol. Soc. Argent. Bot. 24: 169–178.
- . 1991. Rehabilitación del género *Galianthe* (Rubiaceae). Bol. Soc. Argent. Bot. 27: 235–249.
- . 2002. Revisión del Género *Galianthe* (Rubiaceae). Tesis Doctoral, Universidad Nacional del Nordeste, Corrientes, Argentina.
- . 2003. Novedades en el género *Galianthe* Griseb. (Rubiaceae-Spermacoaceae) para la flora de Paraguay, en L. Ramella & P. Perret, Notulae ad floram paraguayensem. Candollea 58: 392–398.
- & N. M. Bacigalupo. 1997. Revisión del género *Galianthe* subg. *Ebelia* stat. nov. (Rubiaceae: Spermacoaceae). Ann. Missouri Bot. Gard. 84: 857–877.
- & ———. 2001. *Scandentia*, nuevo género de Rubiaceae-Spermacoaceae. Darwiniana 39(1–2): 29–41.
- Candolle, A. P. de. 1830. Prodromus systematics naturalis regni vegetabilis. Treuttel & Würtz, Paris.
- Chodat, R. H. & E. Hassler. 1904. Plantae Hasslerianae II. Bull. Herb. Boissier 2me. Sér. 4: 188–189.
- Daviña, J. & E. L. Cabral. 1991. Recuentos cromosómicos en *Galianthe* (Rubiaceae). Bol. Soc. Argent. Bot. 27(3–4): 250–252.
- de la Peña, M. R. & J. F. Pensiero. 2004. Plantas Argentinas. Catálogo de Nombres Comunes. L.O.L.A., Buenos Aires.
- Delprete, P. G., L. B. Smith & R. M. Klein. 2004. *Galianthe*. Rubiaceae. Pp. 213–272 en R. Reitz (editor), Flora Ilustrada Catarinense. I Parte, Vol. 1—Generos de A–G. Herbário Barbosa Rodrigues, Itajaí.
- Dessein, S. 2003. Systematic Studies in the Spermacoaceae (Rubiaceae). Tesis Doctoral, Katholieke Universiteit Leuven, Leuven, Belgica.
- Fernandes, A. & P. Bezerra. 1990. Estudo Fitogeográfico do Brasil. Stylus Comunicações, Fortaleza.
- Galati, B. G. 1988. Estudios Embriológicos en la Tribu Spermacoaceae (Rubiaceae). Tesis Doctoral, Universidad de Buenos Aires, Buenos Aires.
- . 1991. Estudios embriológicos en la tribu Spermacoaceae (Rubiaceae). Parte I: Anatomía floral. Microsporogénesis. Megasporogénesis. Bol. Soc. Argent. Bot. 27(1–2): 7–20.
- Grisebach, A. 1879. Symbolae ad floram Argentinam. Göttingen.
- IBAMA (Instituto Brasileiro do Meio Ambiente e dos Recursos Naturais Renováveis). 1998. Unidades de Conservação Federais de Santa Catarina, Brasil, Parque Nacional de São Joaquim. Superintendência de Santa Catarina, Florianópolis.
- Kiehn, N. M. 1985. Karyosystematic studies on *Rubiaceae*: Chromosome counts from Africa, Madagascar, and Mauritius. Pl. Syst. Evol. 149: 89–118.
- . 1986. Karyologische Untersuchungen und DNA Messungen an *Rubiaceae* und ihre Bedeutung für die Systematik dieser Familie. Diss. Form.-Naturwiss. Fak., Univ. Wien.
- . 1995. Chromosome survey of the Rubiaceae. Ann. Missouri Bot. Gard. 82: 398–408.
- Krause, K. 1908. Rubiaceae andinae. Bot. Jahrb. Syst. 40: 348.
- Kuntze, C. O. 1898. Revisio Generum Plantarum, Pt. 3: 123–124. Arthur Felix, Leipzig.
- Lucas, V. & O. Machado. 1944. Contribuição ao estudo das Rubiaceas medicinais do Brasil. Revista Fl. Med. 11(1): 1–34.
- Martínez Crovetto, R. 1981. Las plantas utilizadas en medicina popular en el noroeste de Corrientes (República Argentina). Misc. Fund. Miguel Lillo 69: 1–139.
- Pire, S. M. 1997. Género *Galianthe* subg. *Ebelia* (Rubiaceae: Spermacoaceae): Estudio palinológico. Ann. Missouri Bot. Gard. 84: 878–887.
- & E. L. Cabral. 1992. El valor del polen en la revalidación de *Galianthe* (Spermacoaceae-Rubiaceae). Darwiniana 31: 1–10.
- Porto, M. L., S. M. C. Jacques, S. T. Miotto, J. L. Waechter & M. L. Detoni. 1977. Tribu Spermacoaceae (Rubiaceae). En A. R. Schulz (editor), Fl. II. Rio Grande do Sul. Bol. Inst. Centr. Bioci. Univ. Fed. Rio Grande do Sul, Sér. Bot. 35: 1–144.
- Robbrecht, E. 1988. Tropical Woody Rubiaceae. Characteristic features and progressions. Contributions to a new subfamilial classification. Opera Bot. Belg. 1: 1–271.
- Schumann, K. 1888. Rubiaceae. En C. Martius, Flora Brasiliensis 6(6): 62–71.
- . 1899. Rubiaceae Africanæ. Beitrage zur Flora von Africa. XIX. Bot. Jahrb. Syst. 28: 112.
- Smith, L. B. 1958. Notes on South American phanerogams. J. Wash. Acad. Sci. 48: 284.

APÉNDICE 1. Lista de especies. Los números se aplican solamente al Apéndice 2.

1. *Galianthe andersonii* E. L. Cabral
2. *Galianthe angustifolia* (Cham. & Schltdl.) E. L. Cabral
3. *Galianthe aurelii* E. L. Cabral
4. *Galianthe bisepala* E. L. Cabral
5. *Galianthe canindeyuensis* E. L. Cabral
6. *Galianthe centranthoides* (Cham. & Schltdl.) E. L. Cabral
7. *Galianthe chiquitosiana* E. L. Cabral
8. *Galianthe chodatiana* (Standl.) E. L. Cabral
9. *Galianthe cyperoides* (Chodat & Hassl.) E. L. Cabral
10. *Galianthe elegans* E. L. Cabral
11. *Galianthe equisetoides* (Cham. & Schltdl.) E. L. Cabral
12. *Galianthe eupatorioides* (Cham. & Schltdl.) E. L. Cabral
13. *Galianthe fastigiata* Griseb.
14. *Galianthe gertii* E. L. Cabral
15. *Galianthe grandifolia* E. L. Cabral
16. *Galianthe guaranitica* (Chodat & Hassl.) E. L. Cabral
17. *Galianthe hassleriana* (Chodat) E. L. Cabral
18. *Galianthe kempffiana* E. L. Cabral
19. *Galianthe krausei* (Suess.) E. L. Cabral
20. *Galianthe lanceifolia* E. L. Cabral
21. *Galianthe latistipula* E. L. Cabral
22. *Galianthe laxa* (Cham. & Schltdl.) E. L. Cabral
 - G. laxa* subsp. *laxa*
 - G. laxa* subsp. *paraguariensis* (Chodat) E. L. Cabral

23. *Galianthe liliifolia* (Standl.) E. L. Cabral
24. *Galianthe linearifolia* E. L. Cabral
25. *Galianthe longifolia* (Standl.) E. L. Cabral
26. *Galianthe longisepala* E. L. Cabral
27. *Galianthe macedoi* E. L. Cabral
28. *Galianthe matogrossiana* E. L. Cabral
29. *Galianthe montesii* E. L. Cabral
30. *Galianthe parvula* E. L. Cabral
31. *Galianthe peruviana* (Pers.) E. L. Cabral
32. *Galianthe pseudopeciolata* E. L. Cabral
33. *Galianthe ramosa* E. L. Cabral
34. *Galianthe reitzii* E. L. Cabral
35. *Galianthe souzae* E. L. Cabral & Bacigalupo
36. *Galianthe sudyungensis* E. L. Cabral
37. *Galianthe thalictroides* (K. Schum.) E. L. Cabral
38. *Galianthe valerianoides* (Cham. & Schldtl.) E. L. Cabral
39. *Galianthe verbenoides* (Cham. & Schldtl.) Griseb.

APÉNDICE 2. Índice de colecciones. Cada espécimen es citado por el nombre del primer colector en el caso en que más de dos colectores hayan participado de la colección; si fueron dos colectores se citan ambos. Se indica entre paréntesis el número de orden del taxón a que se corresponde (véase Apéndice 1).

ABBOTT, R. 16495 (35); ABRUZZI, M. L. 1644 (7); AHUMADA, O. 1002 (37a), 2458 (35), 3038 (14), 4048 (7), 4068 (29), 4079 (8), 6261 (10), 6375 (8), 6718 (37a), 6799 (7), 7332 (37a); AHUMADA, Z. 3337 (30), 3361 (27); ALLEM, A. 388 (26), 464 (26), 529 (16), 868 (16); ALMEIDA, S. P. 69 (26); ALVARENGA, D. 534 (26), 604 (16), 712 (10); ALVES, M. A. 25 (10); ANDERSON, W. R. 6261 (10), 8529 (31), 8717 (31), 9599 (20), 9835 (37a), 10010 (37a), 10047 (10), 10109 (13), 12436 (24), 12479 (24), 35231 (31); ANDRADE, P. 1192 (1); ANISITS, J. s.n. (3), 514 (3); ARBO, M. M. 1893 (8), 1952 (35), 2071 (8), 2138 (35), 2436 (8), 2450 (8), 2875 (3), 3024 (26), 3038 (14), 3366 (26), 4153 (24), 4167 (24), 4581 (10), 4597 (24), 4896 (24), 5019 (10), 5197 (10), 5889 (37a), 6144 (8), 6468 (35); ARENAS, P. 291 (36), 662 (24), 1217 (37b), 1306 (37b), 1630 (36), 2911 (37b); ARRILLAGA, B. 1898 (37a); ASSIS, V. 208 (24); AZEVEDO, M. L. 582 (10).

BACIGALUPO, N. 1151 (32); BADINI, J. 2086 (1), 4416 (30), 19677 (10), 20647 (30), 21996 (1), 21997 (1), 22703 (30), 23168 (1), 24029 (30), 25592 (1), 26193 (1); BALANSA, B. 1742 (30), 1742a (30), 1743b (3), 1743c (3), 1744 (6), 1745 (2), 1746 (29), 1747 (5), 1748a (32), 1748 (37b), 4551 (30); BARBOSA RODRÍGUEZ, J. 224 (1); BARCLAY, G. 21 B 112 (35); BARRETO, K. 2976 (28), 3270 (28); BATTURA, N. 1157 (30); BECK, S. 6636 (35), 6670 (35), 6714 (35), 6765 A (24), 7103 A (24); BELLO, 288 (1); BERNARDI, L. 18640 (3), 18648 (3), 18733 (3), 18735 (8), 18756 (32); BERRO, M. 4364 (37a); BERTONI, J. 18652 (37a); BERTONI, M. 618 (29), 1348 (37a), 2370 (8), 5485 (35); BOECHAT, S. s.n. (30); BONPLAND, A. 1024 (8); BORDAS, E. 4011 (37b), 4372 (36); BRADE, A. 5266 (16), 6783 (16), 6785 (3), 6797 (1), 12356 (1), 12862 (7); BRAGA, R. et al. 165 (18), 266 (39); BRESCIA, O. et al. 3957 (8), 4089 (15), 4454 (37b), 5035 (35); BRITZ, R. M. s.n. (30); BUCHTIEN, O. 765 (37a); BUCK, H. 28042 (39); BUENO, O. 1154 (39), 1234 (39), 3624 (39), 17897 (39); BURKART, A. 8367 (37a), 19740 (30), 23147 (37a); BUSELATO, L. 19 (37a).

CABALLERO MARMORI, G. 255 (35), 860 (17); CABALLERO PARDO, R. 24 (33); CABRAL, E. 159 (8), 166 (8), 180 (35), 181 (8), 242 (35), 274 (35), 326 (35), 337 (8), 356 (35), 387 (8), 461 (29), 470 (29), 473 (3), 478 (8),

486 (39), 521 (35), 624 (35), 667 (3), 668 (35), 669 (8), 674 (30), 668 (35), 686 (35); CABRERA, A. L. 4190 (37a), 12370 (8), 13062 (33), 21387 (35), 28212 (3), 28423 (8), 29237 (35), 33573 (35), 33575 (35), 33594 (35); CAMARGO, O. 57508 (3); CAMPOS, S. M. 148 (16); CAMPOS NOVAES, J. s.n. (1); CAMPOS PORTO, P. 3266 (1), 3267 (301); CAPELL, P. s.n. (1); CARNEVALI, R. 5122 (37a), 6401 (8); CASTELLANOS, A. 21761 (26), 24690 (4); CHARPIN, A. 21387 (35); CHODAT, R. s.n. (8), 279 (36), 378 (37b), 799 (37b), 810 (37b); CLAUSSEN, P. 1839, s.n. (10), 1840, s.n. (10), s.n. (16), 17 (16), 205 (10), 1841, s.n. (16); CORDEIRO, J. et al. 392 (4), 890 (4), 932 (9), 1576 (18); CORREA, A. 521 (33); CORREA, M. 5049 (37a), 7930 (37a); CORREA GOMES JR., J. 1437 (23), 1655 (16), 1747 (35); CRUZ, J. M. 240 (4); CUSATO, L. 1327 (37a), 1429 (37a).

DALY, D. C. 2175 (34), 2240 (37a); DA SILVA, M. A. 1915, (26); DAVIDSE, G. 10523 (10), 11294 (35); DAVIÑA, J. 146 (35); DAVIS, P. H. 60014 (10), 60147 (26); DAWSON, E. Y. 14276 (24); DE BARROS, F. 2517 (10); DEGEN, R. 154 (37b), 210 (37a), 253 (37a), 480 (36), 2897 (35), 3301 (35); DE LIMA, H. C. 1020 (10); DE LIMA, J. 48989 (29); DEL PUERTO, O. 3197 (3), 7607 (3); DE MARINIS, G. 90 (35); DEMATTEIS, M. 720 (8); DESCOBERTO, S. A. 75 (10); DE SOUZA, H. C. 10929 (1); DETONI, E. M. 65 (8); DI FERNANDO, s.n. (8); DOMBEY, J. s.n. (24); DOMBROWSKI, L. 715 (6), 1005 (30), 1711 (4), 2231 (4), 2920 (4), 3862 (4), 4309 (37a), 4553 (18), 5515 (4), 6462 (6), 6682 (18), 6772 (4), 6869 (18); DUARTE, A. P. s.n. (16), 661 (30), 2336 (16), 2529 (24), 8475 (1), 8805 (24), 9622 (24), 9694 (1), 9950 (26), 10051 (16), 10235 (1), 10397 (30), 13073 (16); DUARTE, E. 10373 (10); DUARTE, M. 1118 (37a); DURÉ, R. 106 (2); DUSÉN, P. 2665 (18), 3474 (4), 7303 (18); 7534 (3), 7790 (30), 9446 (18), 10825 (4), 13384 (4), 14411 (9), 16033 (29), 16269 (18).

EDWALL, G. s.n. (30); EGLER, W. 60000 (3); EGYDIO, I. 2 (8); EKMAN, E. L. 1350 (9); EMYGDIO, L. 3111 (37a).

FALKENBERG, D. B. 4320 (9); FERNANDES, A. 46 (37a); FERNÁNDEZ, J. 668 (7); FERNÁNDEZ CASAS, F. J. 5768 (30), 5963 (5), 5983 (11), 6133 (32); FERRARO, L. 2420 (37a), 2465 (37a), 2978 (35); FERRUCCI, S. 497 (37a), 734 (37b), 750 (37b), 759 (37b); FIEBRIG, K. 124 (37a), 500 (3), 650 (8), 755 (5), 2729 (37a), 4323 (37a), 6076 (30), 6426 (30), 6491 (8); FILGUEIRAS, T. S. 1685 (14), 1727 (14); FLEIG 197 (39); FLOSSDORF, G. 2 (8), 24580 (3); FONTANA, J. L. 259 (30), F55-83 (29); FONTELLA, J. 1285 (4); FONTES VIEIRA, R. 622 (26); FRANCO, C. E. 4 (10); FRAZÃO, A. 1917 (16); FRIEDRICH, L. 28807 (1); FROMM, T. 408 (6); FRUCHARD, M. s.n. (37a), 203 (37a), 404 (8); FUENTES, A. 1782 (13), 2598 (35); FURLAN, A. SPF 32772 (24).

GALLINAL, G. 5610 (8); GAMBIAGGI 5815 (35); GARCÍA, A. 03 (35); GARCÍA, W. G. 14024 (26); GARDNER, G. 3785 (10); GAUDICHAUD, C. s.n. (3), 1114 (37a), 1115 (3), 1117 (8), 1118 (39); GEHRT, G. 3529 (3); GILBERT, O. s.n. (8), 86625 (8); GINZBARG, S. 379 (8), 480 (35), 521 (35), 560 (35); GIULIETTI, A. M. 13601 (1); GLAZIOU, A. 1494a (8), 8164 (1), 9972 (29), 12780 (30), 12906 (26), 17640 (24), 18290 (16), 21506 (26), 21507 (26); GÓMEZ, R. BAB 91074 (35); GOODLAND, R. 301 (14); GOUVEA, W. L. 723 (16); GRANDI, T. S. 16553 (1); GUAGLIANONE, R. 2837 (37a); GUILLEN, R. 4774 (34); GUIMARÃES, E. 47 (37a), 200 (14).

HACKER, J. 1000 B (35); HAENKE, T. s.n. (24); HAGELUND, K. 1408 (29), 1770 (30), 11989 (3), 13744 (39), 14801 (8); HAHN, W. s.n. (37a), 848 (5), 1615 (35); HANDRO, O. 29 (3); HASSLER, E. 1278 (3), 1814 (30),

3263 (37b), 3314 (3), 3714 (3), 4022 (36), 4249 (3), 4338 (5), 4561 (5), 4562 (12), 4829 (5), 5089 (30), 5165 (4), 5168 (4), 5594 (11), 5689 (12), 5757 (8), 5771 (29), 5776 (3), 5839 (2), 6508 (37b), 6516 (3), 6739 (30), 6745 (8), 6833 (30), 6976 (3), 7775 (37a), 7895 (35), 7999 (37a), 8784A p.p. (5), 8784 B p.p. (32), 8850 (3), 9028 (5), 9156 (2), 9213 (3), 9771 (3), 9820 (2), 9942 (29), 10702 (30), 11733 (37b), 11733A p.p. (37a); HATSCHBACH, G. 1113 (18), 1917 (37a), 4288 (29), 5293 (30), 6695 (9), 9741 (37a), 10692 (4), 10893 (3), 18206 (9), 18226 (18), 20659 (18), 20766 (9), 23388 (9), 23392 (9), 23935 (9), 25970 (4), 26028 (11), 26128 (25), 26316 (9), 26438 (39), 28726 (24), 29439 (21), 33914 (25), 40235 (4), 47282 (23), 47302 (18), 48520 (23), 48863 (4), 58622 (25), 58771 (23), 59293 (10), 59471(10), 59668 (4), 59896 (10), 59924 (26), 59989 (10), 61808 (10), 62827 (37a), 64065 (26), 64300 (10), 64719 (10), 65006 (1), 69458 (1), 70068 (26), 70519 (10), 70625 (10), 70740 (10), 70867 (10), 71162 (37a), 71782 (25); HAUFF, I. 20 (1), 96 (1); HENZ, E. 33227 (7); HERINGER, E. 157 (16), 2580 (26), 4577 (10), 5910 (26), 6459 (10), 6832 (10), 8757 (26), 8834 (16), 12802 (26), 15742 (26), 16726 (26), 21962 (24); HERTEL, R. 170 (4); HERTER, R. 86625 (8); HIME 784 (24); HOEHNE, F. C. s.n. (10), s.n. (30), s.n. SP 11819 (14), s.n. 14511 (14), 10860 (30), 13513 (30), 17474 (3), 23054 (4), 23269 (6), 28542 (1); HOEHNE, W. s.n. (30), s.n. (37a); HOFFMANN, W. 224 (24); HOLMBERG, E. 100 (35); HOLMGREN, O. 25450 (35); HUIDOBRO, A. M. 4827 (8); HUMBERT, H. et al. 30644 (24); HURRELL, J. et al. 3356 (37a).

IBARROLA, T. 3774 (3), 4250 (35); IMAGUIRE, I. 1734 (9), 5682 (4); INFRÁN, P. 1128 (37b); IRGANG, B. 7834 (7); IRWIN, H. 1879 (37b), 1989 (1), 3263 (37b), 3783 (37b), 4022 (36), 6508 (37b), 10223 (26), 10616 (26), 12244 (16), 12311 (24), 12825 (24), 13307 (19), 14104 (10), 14782 (10), 15204 (10), 15383 (26), 15466 (10), 15952 (10), 16377 (10), 16886 (37a), 19238 (26), 19584 (1), 19826 (24), 19990 (24), 20535 (24), 21806 (30), 21857 (10), 22027 (30), 22251 (16), 22835 (10), 22949 (24), 23010 (24), 23179 (10), 23489 (31), 23873 (10), 24002 (10), 24763 (3), 24802 (24), 25308 (10), 25504 (19), 26299 (10), 26820 (10), 28120 (31), 28166 (10), 28602 (31), 34117 (26); ISABELLE, M. 9 (39).

JARDIM, A. 366 (24), 2242 (37a); JIMÉNEZ, B. 2001b (5); JIMÉNEZ, J. 1235 (13); JOLY, A. B. 932 (24), 2292 (24); JOLY, J. 866 (24); JÖRGENSEN, P. 2179 (3), 2634 (3), 3520 (5), 3706 (37a), 3714 A (3), 3714 (30), 4308 (8), 4309 (29), 4922 (25), 4926 (2); JUNG-MENDACOLLI, S. L. 1377 (37a); JÜRGENS, G. 460 (30).

KIRKBRIDE, J. 1710 (26), 1745 (30), 3056 (35), 3162 (10), 4307 (26), 4686 (26), 4765 (10), 4994 A (26), 5334 (10); KIRKBRIDE, M. C. G. 1010 (26), 1077 (26); KILL-EEN, T. 4715 (13), 5230 (13), 6492 (13), 6530 (13), 7405 (37a); KIRIZAWA, M. 403 (10); KLEIN, R. 587 (37a), 2185 (37a), 3242 (4), 3360 (30), 3544 (30), 3709 (30), 3814 (4), 4719a (39); KÖRNER, H. 57332 (39); KRAPOVICKAS, A. 3056 (35), 12033 (8), 12066 (8), 12413 (37b), 12478 (37b), 13382 (37b), 13477 (37b), 14117 (35), 15120 (8), 15239 (37a), 15615 (37a), 16388 (8), 16568 (7), 16922 (8), 16924 (8), 16926 (29), 17173 (8), 20876 (4), 21025 (8), 21139 (29), 21191 (30), 21304 (30), 21471 (8), 22838 (8), 23096 (4), 24883 (8), 25039 (37a), 25186 (30), 25651 (8), 25756 (37a), 26151 (29), 28697 (35), 28791 (3), 28873 (37a), 31404 (37a), 31562 (35), 31673 (35), 32281 (35), 34154 (8), 34214 (8), 34386 (21), 34533 (35), 35279 (35), 35308 (1), 36099 (35), 36180 (37a), 36289 (35), 37579 (39), 37637 (8), 37801 (30), 38381 (8), 38518 (3), 39042 (37a), 39054 (37a), 39647 (4), 39679 (30), 39687 (4), 40856 (18), 40875 (6), 40876 (4), 41108 (37a), 41109 (30), 41896 (37b), 41954 (15), 42015 (30), 43020 (14), 43155 (14), 43486 (37a), 43925 (35),

44664 (8), 45169 (37b), 45444 (35), 45529 (37b), 45672 (8); KREFGER, G. 7638 (4); KRIEGER, L. 16223 (10); KUHLMANN, J. G. s.n. (14); KUHLMANN, M. 2487 (1), 3582 (10); KUMMROW, R. 85 (4), 663 (18), 1401 (4), 1795 (4), 2360 (4), 3397 (9).

LANDRUM, L. 2807 (1); LANGERON, M. s.n. (8); LEGNAME, P. 5980 (37a), 10194 (37a); LEGRAND, D. 2015 (3); LEITÃO FILHO, H. F. 9293 (35), 9315 (35), 15319 (1), 32986 (37a); LEITE, E. 3468 (25); LEITE, P. s.n. (1), 2296 (30); LEWIS, M. 37173 (38), 37202 (38); LIMA, A. 131 (37a); LIMA, S. 58-2979 (10); LINDEMAN, J. C. s.n. (30), 309 (4), 6022 (10); LORENTZ, P. G. s.n. (37a), 504 (37a), 803 (8), 804 (3), 1486 (3), 1729 (3); LOSSEN, W. 563 (7); LOURTEIG, A. 2277 (30); LUEDERWALDT, H. s.n. (1); LURVEY, E. 249 (8), 256 (3), 294 (37b).

MACEDO, A. 67 (35), 1468 (20), 3506 (26); MAGENTA, M. A. 23 (37a); MAGNANO 221 (26); MALME, G. O. s.n. (37a), 1060 (30), 1824 (8), 3275 (37a), 3446 (13); MAMANI, F. 634 (37a), 1127 (37a), 1254 (34); MANTOVANI, W. 1864 (10); MARCHESI, E. 10209 (3); MARCONDES-FERREIRA, W. 777 (10); MARÍN 1376 (24); MARTÍNEZ CROVETTO, R. 4020 (37a), 4183 (37a), 4617 (8), 4898 (8), 8168 (8); MARTINS, F. R. 247 (35), 1677 (1); MARTINS, S. A. 462 (3); MARTIUS, C. 997 (24); MATTHEWS, D. M. 1150 (24); MATTOS, J. 12240 (10), 13973 (29), 14323 (1); MATTOS FILHO, A. s.n. (4); McDANIEL, S. 11968 (37b); MEDINA, B. 103 (22), 170 (8), 181 (35), 184 (8), 287 (35); MELLO, F. 425 (14); MENACHO, M. 596 (35), 711 (35); MENDONÇA, R. 1191 (19); MENEGES, J. 6236 (24); MENEZES, N. 6236 (24); MENHOFER, O. X1411 (35); MERELLES, F. 1525 (37b), 2371 (30), 2779 (35), 2872 (35), 4572 (35), 5023 (35); MEYER, T. 920 (37a), 11024 (37a), 11583 (35), 11691 (35); MICHEL, R. 195 (35); MIOTTO, S. 237 (29), 805 (15); MOLLURA, R. 4020 (37a), 4183 (37a), 5574 (37a), 11175 (35); MONTES, J. 575 (29), 723 (35), 1287 (8), 1475 (35), 1633 (8), 1720 (8), 7036 (22), 9418 (35), 9448 (29), 9764 (22), 10323 (8), 14717 (35), 15072 (35), 15159 (35), 15495 (35), 15694 (35), 27241 (35), 27310 (35); MONTOVANI 7792 (24); MOREIRA, I. 3 (6); MOREIRA FILHO, H. 472 (6); MORONG, T. 610 (35); MORRETES, B. s.n. (10); MORRONE, O. 968 (37a), 1017 (35), 1023 (35), 1867 (35); MOSTACEDO, B. 1778 (13), 1853 (13), 2121 (13), 2160 (13); MROGINSKI, L. 320 (35), 344 (37a); MUSCON, M. 3382 (9).

NAVARRO DE ANDRADE, E. s.n. (10); NEE, M. 35410 (37a), 35763 (35), 35805 (35), 36374 (35), 37729 (35), 38584 (35), 39065 (37a), 39444 (35), 39719 (35), 40362 (35), 40489 (35), 41607 (35), 42190 (35), 43413 (24), 45202 (37a), 46651 (24); NEIFF, J. J. 593 (35); NETO, E. 2863 (16); NICORA, E. 4625 (37a); NOGUEIRA, E. 46 (26); NOVARA, L. 2777 (33), 9630 (33).

OLIVEIRA, E. 173 (7); OLIVEIRA, J. SPF 36156 (24); OLIVEIRA, P. I. 173 (18), 331 (30), 835 (30); ORBIGNY, A. d', 550 (35), 882 (34), 950 (35); OSTEN, C. 3958 (3), 9085 (37b), 18954 (37a), 20187 (3), 20188 (8).

PABS, G. 5449 (7), 6423 (7); PALACIOS, A. 286 (8), 3885 (24); PALACIOS, M. 3861 (1); PALACIOS, R. 73 (37a); PALACIOS-CUEZZO, O. 880 (39), 1318 (8), 1412 (8), 2167 (37a); PARTRIDGE, W. 60650 (7), 68467 (7); PAVÓN, J. 36 (24); PEDERSEN, T. 181 (3), 801 (8), 3211 (35), 3233 (8), 4781 (8), 5405 (7), 5418 (37a), 5432 (30), 5452 (29), 8192 (37a), 9283 (32), 9519 (5), 12138 (14), 15616 (10), 15795 (37a); PEREDO, I. s.n. (35); PEREIRA, B. 467 (30), 1476 (24), 2054 (10); PEREIRA, E. 1392 (10), 2417 (1), 3211 (35), 5157 (4), 5418 (37a), 7651 (37a), 7971 (3), 8087 (4), 8192 (37a), 8376 (37a), 8486 (8), 8526 (7), 9283 (32), 15795 (37a), 30819 (8); PEREIRA, G. 4807 (29); PEREIRA, S. C. 03509

(10), 1504 (1); PERSSON, O. 298 (35); PHILCOX, D. 4305 (16); PICKEL, D. 4463 (1); PIEROTTI, S. s.n. (37a), 6516 (37a), 6606 (37a); PIRANI, J. R. 420 (4), 1490 (10); PIRES, J. 9731 (10); PEYTON 202 A (24); PLK & URBANO 10185 (24); POHL, J. s.n. (3); POLIQUESI, C. B. 70 (6); PORTO, M. L. 347 (8), 890 (37a), 1000 (3), 1153 (8), 1154 (29), 1287 (8), 1305 (8), 1328 (8), 1332 (29), 1346 (39), 1347 (8), 1378 (7), 1421 (8), 1433 (8); POTT, A. 2033 (37a); POTT, V. 463 (8); PRAUSE, J. s.n. (8); PROCTOR, G. 46852 (35).

QUARÍN, C. 295 (37a), 2292 (3), 3517 (3); QUINTANA, M. 151 (35).

RAMBO, B. 2233 (39), 8690 (39), 8763 (15), 11408 (15), 28228 (15), 29388 (3), 31722 (30), 34859 (15), 38661 (8), 39809 (7), 40482 (8), 40866 (3), 41243 (39), 42585 (8), 44454 (3), 44966 (39), 45393 (39), 45843 (8), 46408 (37a), 46549 (39), 49624 (30), 49838 (37a), 50047 (15), 50048 (39), 50139 (30), 51549 (30), 52052 (15), 52053 (8), 53473 (30), 56427 (30), 56578 (30), 56661 (15), 56730 (8), 56790 (30), 56831 (30), 58564 (30), 59164 (8), 60307 (29); RAMOS, A. R. 646 (10); RATTER, J. A. 2835 (26), 2881 (10), 3440 (10); REGNELL, A. F. 1849, I-175 (16), 1870, I-175 (30); REINECK, C. 6 (17), 98 (17), 486 (3); REITZ, R. 553 (30), 869 C (3), 1026 (30), 2072 (39), 2969 (27), 4562 (37a), 6138 (9), 6416 (15), 6426 (9), 6511 (15), 7688 (27), 8419 (27), 10498 (9), 13987 (3), 14286 (3), 16955 (37a), 17406 (18), 17504 (4), 17628 (30), 17898 (4); RIBAS, O. G. 604 (4), 957 (9), 1288 (37a), 1565 (4), 2276 (9); RIBEIRO, J. 9843 (10); RIEDEL, L. 163 (3), 1511 (16); RIZZO, A. 22 (10), 5840 (30); ROBERT, A. 368 (37a); RODRÍGUEZ, M. 389 (35), 488 (37a), 573 (37a); RODRÍGUEZ, R. 679 (8), 766 (30); ROJAS, T. 1760 (37b), 4885 (32), 9820 (3), 10102 (25), 10082 (23), 11059 (35), 12705 (37b), 12724 (37b), 12735 (8), 13951 (3), 14582 (37b); ROMANCZUK, C. 197 (8), 356 (8); ROMBOUTS, J. 3717 (35); ROSENGURTT, B. 5800 (3), 5835 (8), 8145 (37a); ROTH, L. 1678 (24); RUIZ LÓPEZ, H. & PAVÓN, J. A. s.n. (24); RUSBY, H. 2107 (37a).

SAINT HILAIRE, A. 706 (1), 2349 (1), 2653 (29), C2 2460 bis (8), CAT. C2 1841 bis (8), 1472 (3), 1499 P (29), 2653 (29); SAKANE, M. 199 (30), 202 (1); SALDÍAS, M. 196 (24), 4000 (37a); SANO, S. M. 76 (26); SANTOS, E. 2107 (6), 3019 (6); SANTOS, I. F. 31 (14), 1566 (10); SARAVIA TOLEDO, C. 10896 (37a), 11356 (37a), 11457 (35); SCHIAVONE, M. 11712 (37a); SCHININI, A. 20 (36), 1294 (37b), 1393 (36), 1444 (32), 1657 (8), 2111 (32), 2188 (35), 2683 (8), 3496 (11), 5038 (32), 5666 (8), 5804 (30), 5859 (35), 6026 (37a), 6244 (37b), 6497 (3), 6719 (37b), 7239 (37a), 8080 (8), 8147 (37a), 8257 (3), 8436 (35), 9075 (37a), 9125 (5), 10452 (29), 10690 (8), 11306 (8), 12955 (37a), 13382 (37b), 14094 (3), 14416 (7), 15468 (35), 15742 (3), 15902 (3), 16686 (7), 16705 (37a), 16940 (37a), 17557 (8), 19120 (3), 19884 (37a), 20169 (35), 20490 (35), 20671 (37a), 21274 (36), 21317 (37b), 21788 (8), 21818 (30), 21918 (35), 21939 (8), 21948 (37b), 21964 (5), 22907 (5), 22915 (37A), 23091 (37a), 23198 (37a), 23212 (5), 23312 (3), 23424 (8), 23467 (29), 23587 (30), 23664 (3), 23767 (37a), 23798 (37a), 23956 (36), 24296 a y b (30), 24715 (37a), 25997 (35), 26063 (8), 26123 (35), 27227 a y b (17), 27404 (35), 27618 (30), 27642 (35), 27782 (37a), 27931 (37a), 28111 (5), 28174 (35), 28236 (35), 28256 a y b (37a), 29353 (35), 30098 (8), 30120 (29), 33309 (5), 33398 (37a), 33496 (11), 33581 (11), 33626 (23); SCHMIT, L. 097 (38); SCHREITER, R. 3525 (37a), 5424 (33); SCHULTZ, A. s.n. (30), 3990 (15), 5425 (37a), 6879 (8); SCHWACKE, C. s.n.

(1), s.n. (37a), 2709 (29); SCHWARZ, G. J. 595 (35), 1353 (29), 1462 (8), 1498 (8), 1588 (35), 1772 (35), 1795 (29), 1884 (35), 2008 (35), 2113 (29), 2206 (35), 2464 (35), 2569 (35), 2648 (35), 2749 (35), 2767 (35), 2811 (35), 2859 (35), 3570 (8), 3926 (35), 3965 (29), 4273 (37a), 5052 (29), 5204 (8), 5299 (3), 5477 (35), 5880 (35), 5924 (35), 8736 (3), 10355 (35), 10432 (35), 11131(36), 11401 (8), 11791 (25), 12129 (25); SCHWINDT, E. 43 (35), 160 (35), 478 (29), 1472 (35), 1909 (35), 1993 (37a), 2220 (29), 2292 (8), 2387 (3), 4057 (35), 4663 (35); SCOLNIK, R. 1048 (24); SEHNEM, S. 1489 (39), 2388 (39), 8003 (35); SEIDEL, R. et al. 156 (35), 190 (35), 422 (35), 3084 (35); SELLOW, F. 217 (29), 1116 (15), 1517 (3), 1570 (8), 1733 (30), 1735 (24), 4993 (3); SEMIR, J. 561 (24), 601 (24), 791 (24), 2647 (24), 2788 (24), 3695 (24), 4060 (24), 17493 (14), 20483 (26); SHEPHERD, G. J. 7099 (10), 7167 (16), 12218 (1); SILVA, J. M. et al. 1413 (4), 2727 (9); SILVEIRA, N. 3824 (15), 5929 (7), 7314 (39), 7339 (39), 7963 (7), 8689 (8), 11047 (7); SIMÃO, R. 419 (1); SIMONIS, J. E. 84 (37a), 179 (37a); SMITH, L. 97 (14), 10151 (27), 11668 (39), 13683 (30), 14292 (30), 14921 (4), 15622 (30); SOARES, Z. 233 (8), 265 (8); SOBRAL, M. s.n. (39), 1463 (8), 1657 (7), 3719 (8), 4830 (27), 4939 (30); SOLIS NEFFA, V. 272 (8); SOLOMON, J. 6920 (35), 7721 (34), 10159 (37a), 13511 (35), 14019 (35), 14128 (37a), 18018 (37a), 18546 (35), 18639 (35); SORIA, N. 200 (37b), 920 (32), 1378 (37b), 1700 (35), 3857 (37a), 5945 (35), 7573 (35); SOUZA, M. H. s.n. (10); SOUZA, V. C. 2339 (30), 4747 (28), 4431 (28), 5882 (37a), 6112 (28), 7270 (30); SPARRE, B. 1996 (30); SPARRE, O. & VERVOORST, F. 1083 (36); SPEGAZZINI, C. s.n. (17), 10381 (3), 16557 (29), 18947 (8); STEHMANN, G. J. 1295 (27); STEINBACH, R. F. 332 (35), 766 (35), 2005 (35), 7034 (35); STRIEDER 33020 (39); STUBBLEBINE, W. H. 565 (1); STUTZ, H. 2144 (35); SUCRE, D. 399 (26), 547 (10), 6804 (1), 10451 (14), 10459 (30), 10523 (25).

TADASHI, S. 133 (2), 275 (2); TAMASHIRO, J. 873 (1); TEIXEIRA, B. 102 (1); TEIXEIRA, W. 26303 (1); TESMANN, G. s.n. (18); TIRITAN, O. 451 (35), 578 (37a), 613 (37a), 663 (37a); TORRICO, G. 335 (33); TOVAR, O. 1810 (24); TRESSSENS, S. 1535 (29), 1621 (37a), 1684 (3), 1726 (8), 1885 (30), 1886 (29), 1890 (10), 1891 (8), 2610 (35), 2687 a y b (30), 2812 (29), 2892 (29), 4693 (37a), 4735 (37a), 5000 (35), 5544 (37a), 5555 (35), 5558 (35), 5599 (37a); TROLL, W. 1137 (33); TÜRPE, A. M. 4892 (37a).

ULE, E. 1037 (30); UNGARETTI, I. 446 (8), 1818 (39); USTERI, A. s.n. (1).

VANESSA, V. 6635 (1); VANNI, R. 328 (35), 422 (8), 597 (35), 669 (29), 758 (35), 1077 (8), 1329 (35), 2673 (37a); VARGAS, L. 790 (24); VÁZQUEZ AVILA, M. 381 (35); VENTURI, A. 133 (3); VIDAL, R. 276 (1), 587 (3); VIEGAS, A. 3812 (10).

WALTER, B. M. 057 (10), 124 (10), 157 (10); WARMING, E. s.n. (1), s.n. (16); WEDDELL, M. s.n. (24), 1408 (24); WIDGREN, J. 1845 (30); WILLIAMS, L. 5568 (24), 6640 (24); WOOD, J. R. 8137 (33); WOOLSTON, A. 599 (3), 1241 (3); WOYTKOWSKI, F. 6536 (24).

ZARDINI, E. 3867 (36), 7281 (36), 8730 (36), 10216 (36), 11695 (36), 12655 (36), 25517 (5), 25670 (5), 26027 (5), 26104 (37b), 26269 (36), 26902 (37b), 27302 (37b), 27863 (37b), 29020 (36), 30036 (37b), 32302 (37b), 36464 (37b), 36493 (36), 36531 (36), 41991 (30), 42813 (2), 43013 (2), 45560 (5), 47874 (11), 47903 (11), 47938 (5); ZULOAGA, F. 1516 (35).

PHYLOGENETIC PLACEMENT OF
THE TRIBE RETINIPHYLLEAE
AMONG THE SUBFAMILY
IXOROIDEAE (RUBIACEAE)¹

Rocio Cortés-B.,^{2,5} Piero G. Delprete,³ and
Timothy J. Motley^{4,5}

ABSTRACT

The tribe Retiniphyllae and its single genus *Retiniphyllum* Bonpl. contains 22 species of shrubs and small trees that grow in white sand soils mostly in the Guayana Region of South America. The circumscription of the tribe is based on the diagnostic characteristic of two collateral and pendulous ovules per locule, a rare condition in the Rubiaceae. However, for the same reason, its placement within the family has been controversial. The monophyly and systematic position of the tribe Retiniphyllae and *Retiniphyllum* were tested based on a phylogenetic analysis of *trnL-F* and *rps16* sequence data. The results confirm the monophyly of the tribe and genus *Retiniphyllum*. The tribe is placed sister to the core members of the subfamily Ixoroideae s. str. The genera *Botryarrhena* Ducke and *Scyphiphora* C. F. Gaertn. are not related to the tribe Retiniphyllae, as formerly hypothesized.

Key words: *Botryarrhena*, Guayana Region, Ixoroideae, Retiniphyllae, *Retiniphyllum*, *rps16*, Rubiaceae, *Scyphiphora*, *trnL-F*.

The tribe Retiniphyllae includes only the genus *Retiniphyllum* Bonpl. This genus consists of 22 species of shrubs and small trees that grow on white sand soils in the Neotropics. Most species are distributed in the Guayana Region, and a few reach the Amazon Basin, eastern Andes, and central and eastern Brazil. The Retiniphyllae consists of shrubs or trees characterized by the abundant resin located at apical buds. Each flower is subtended by a bracteole located at the base of the pedicel and an involucl (calyculus) located at the top of the pedicel. Flowers have corollas with contorted aestivation, stamens reflexed in anthesis, anthers with basal and apical sterile appendages, a (4 to)5(to 6 to 8)-locular ovary

with two collateral pendulous ovules per locule, drupaceous fruits, and pyrenes normally containing one seed due to the abortion of one ovule. In addition, many species exhibit secondary pollen presentation. Some of these characters are not common in the Rubiaceae, especially the condition of two ovules per locule. In this family, most members have one or many ovules per locule. As a consequence, the tribe Retiniphyllae has been clearly defined and isolated in the family, but for the same reason, its placement within the Rubiaceae has been controversial.

In the earliest systems of classification (Kunth, 1818; Roemer & Schultes, 1818; Jussieu, 1820; Richard, 1830; de Candolle, 1830; Bentham, 1841),

¹ We are grateful to Conciencias-Fulbright-LASPAU, Lehman College, and The New York Botanical Garden for supporting the first author during her doctoral studies at the City University of New York; The Lewis B. and Dorothy Cullman Foundation for supporting the work in the laboratory; the International Association for Plant Taxonomy for partially supporting fieldwork; directors of the herbaria BM, BR, C, COAH, COL, F, G, GH, GUYN, K, M, MO, NY, R, U, UDBC, US, VEN, and W for making their specimens available; E. J. Gouda (Utrecht University, The Netherlands), A. Vogel (Botanical Garden, Leiden University, The Netherlands), T. Nanderborgh, and E. Robbrecht (National Botanical Garden, Meise, Belgium) for help in obtaining fresh leaves at the living collections of their institutions; and G. Aymard, P. Berry, R. Evans, and S. Mori for sharing their field observations, specimens, and photographs. This research was undertaken during a fellowship for Visiting Scientist to Piero Delprete from the Conselho Nacional de Desenvolvimento Científico e Tecnológico (CNPq). A travel grant for the presentation of this work at the Third International Rubiaceae Congress (18–21 September 2006, Katholieke Universiteit, Leuven, Belgium) was provided by the Fund for Scientific Research–Flanders (FWO N. WO.005.05) and the Laboratory of Plant Systematics of Katholieke Universiteit, Leuven, Belgium.

² Herbario Forestal, Universidad Distrital, Campus El Vivero, Avenida Circunvalar–Venado de Oro, Bogotá, Colombia. retiniphyllum@yahoo.com.

³ CNPq Visiting Scientist, Institute of Biological Sciences (ICB-1), Department of General Biology/Botany, Universidade Federal de Goiás, Campus II, 74001-970 Goiânia, Goiás, Brazil. Current address: Institut de Recherche pour le Développement, Botanique et Bioinformatique de l'Architecture des Plantes (AMAP), TA-A51/PS2, Blvd. de la Lironde, 34398 Montpellier Cedex 5, France. pdelprete@hotmail.com.

⁴ Department of Biological Sciences, Old Dominion University, Norfolk, Virginia 23529-0266, U.S.A. tmotley@odu.edu.

⁵ Lewis B. and Dorothy Cullman Program for Molecular Systematics Studies, The New York Botanical Garden, Bronx, New York 10458-5126, U.S.A.

doi: 10.3417/2006198

Table 1. Taxa sampled for the phylogenetic analyses of the *trnL-F* spacer and the *rps16* intron data sets.

Taxa	Voucher	GenBank accession number	
		<i>trnL-F</i>	<i>rps16</i>
<i>Aleisanthia rupestris</i> Ridl.	Tange 45171 (AAU)	AF152660 ³	—
<i>Alibertia edulis</i> (Rich.) A. Rich. in DC.	Jansen-Jacobs 3840 (GB)	AF201029 ¹	—
<i>Alibertia edulis</i> (Rich.) A. Rich. in DC.	Rova 2288 (GB)	—	AF200975 ¹
<i>Amphidasya colombiana</i> (Standl.) Steyerem.	Stahl et al. 3542 (GB)	AF152624 ³	—
<i>Amphidasya ambigua</i> (Standl.) Standl.	taxon 61933	—	AF129271 ⁷
<i>Borojoa patinoi</i> Cuatrec.	Persson et al. 2194 (GB)	AF201034 ¹	AF200984 ¹
<i>Botryarrhena pendula</i> Ducke	Campos 29 (NY)	EU821638	—
<i>Calochone redingii</i> (De Wild.) Keay	Chase 3355 (K)	AF201036 ¹	AF200986 ¹
<i>Calycophyllum spruceanum</i> (Benth.) Hook. f. ex K. Schum.	Hatschbach 62777 (NY)	AY555080 ²	EU821613
<i>Ceriscoides sessiliflora</i> (Wall. ex Kurz) Tirveng.	Maxwell 87-967 (AAU)	AF201039 ¹	AF200989 ¹
<i>Cinchona pitayensis</i> Wedd.	Andersson et al. 2109 (GB)	AF152684 ³	—
<i>Cinchona pubescens</i> Vahl	taxon 50278	—	AF004035 ⁶
<i>Coffea liberica</i> Hiern	Delprete 7357 (NY)	AY555081 ²	EU821614
<i>Condaminea corymbosa</i> (Ruiz & Pav.) DC.	Rova et al. 2084 (S)	AF102406 ⁵	—
<i>Condaminea corymbosa</i> (Ruiz & Pav.) DC.	taxon 60042	—	AF004039 ⁶
<i>Duperrea pavettifolia</i> Pit.	Delprete 7373 (NY)	AY555082 ²	EU821615
<i>Fadogia audruana</i> J. M. Fay, J.-P. LeBrun & Stork	Fay 8901 (NY)	EU821639	EU821616
<i>Ferdinandusa Pohl</i> sp.	Alves 2267 (NY)	AY555083 ²	EU821617
<i>Feretia aeruginescens</i> Stapf	Mwanyambo 154 (NY)	AY555084 ²	EU821618
<i>Gardenia taitensis</i> DC.	Struwe & Albert 1208 (NY)	AF102426 ⁵	—
<i>Gardenia volkensii</i> subsp. <i>spatulifolia</i> Stapf & Hutch.	Rova T011 (GB)	—	AF200996 ¹
<i>Genipa americana</i> L.	Delprete 6522 (NY)	AF152665 ³	—
<i>Genipa americana</i> L.	Persson & Gustafsson 342 (GB)	—	AF200997 ¹
<i>Hippotis brevipes</i> Spruce ex K. Schum.	Woytkowski 5620 (NY)	AF152636 ³	—
<i>Hippotis scarlatina</i> Krause	taxon 172217	—	AF331650 ⁴
<i>Ibetrulia surinamensis</i> Bremek.	Persson et al. 1930 (GB)	AF 201048 ¹	AF201000 ¹
<i>Ixora finlaysoniana</i> Wall. ex G. Don	Delprete 7344 (NY)	AY555085 ²	EU821619
<i>Keetia multiflora</i> (Schum. & Thonn.) Bridson	Delprete 7384 (NY)	AY555086 ²	—
<i>Kutchubaea</i> Fisch. ex DC. sp.	Rodriguez 59 (NY)	AY555087 ²	—
<i>Kutchubaea</i> Fisch. ex DC. sp.	Rodriguez 828 (NY)	—	EU821620
<i>Leptactina leopoldi-secundi</i> Büttner	Delprete 7364 (NY)	AY555088 ²	EU821621
<i>Limnosipanea spruceana</i> Hook. f.	Jansen-Jacobs et al. 2615 (NY)	AY555102 ²	—
<i>Limnosipanea erythraeoides</i> (Cham.) K. Schum.	Macedo 5537 (US)	—	EU821622
<i>Macrosphyra longistyla</i> (DC.) Hook. F. ex Hiern	Bagshawe 1457 (BM)	AF201051 ¹	AF201004 ¹
<i>Mussaenda pubescens</i> Buch.-Ham.	Delprete 7399 (NY)	AY555089 ²	EU821623
<i>Pavetta stenosepala</i> K. Schum.	Delprete 7387 (NY)	AY555090 ²	EU821624
<i>Platycarpum acreanum</i> G. K. Rogers	Cid Ferreira 10407 (NY)	AY555100 ²	—
<i>Polysphaeria</i> Hook. f. sp.	Groves 529 (K)	AF152655 ¹	AF201011 ¹
<i>Posoqueria gracilis</i> (Rudge) Roem. & Schult.	Munzinger 504 (NY)	EU821640	—
<i>Pouchetia baumanniana</i> Büttner	Delprete 7359 (NY)	AY555091 ²	EU821625
<i>Pseudomussaenda flava</i> Verdc.	Andrews 857 (S)	AF152652 ³	—
<i>Psilanthus mannii</i> Hook. f.	Delprete 7349 (NY)	AY555092 ²	—
<i>Psychotria</i> L. sp.	Araújo 1054 (NY)	AY555079 ²	EU821612
<i>Psydrax schimperiana</i> (A. Rich.) Bridson	Delprete 7388 (NY)	EU821641	EU821626
<i>Pyrostria media</i> (A. Rich. ex DC.) Cavaco	Zarucchi 7424 (NY)	EU821642	EU821627
<i>Randia nitida</i> (Kunth) DC.	Delprete 7358 (NY)	AY555093 ²	EU821628
<i>Retiniphyllum concolor</i> (Spruce ex Benth.) Müll. Arg.	Berry 7093 (NY)	EU821643	—
<i>Retiniphyllum concolor</i> (Spruce ex Benth.) Müll. Arg.	Berry 7422 (NY)	—	EU821629
<i>Retiniphyllum maguirei</i> Standl.	Evans 3230 (MO)	EU821646	EU821632
<i>Retiniphyllum rhabdocalyx</i> Müll. Arg.	Cortés 1648 (NY)	EU821644	EU821630
<i>Retiniphyllum schomburgkii</i> (Spruce ex Benth.) Müll. Arg.	Berry 7567 (MO)	EU821645	EU821631
<i>Retiniphyllum secundiflorum</i> Bonpl.	Berry 7457 (MO)	EU821647	EU821633
<i>Rondeletia inermis</i> (Spreng.) Krug & Urb.	Acevedo et al. 7691 (NY)	AF152745 ³	—
<i>Rondeletia portoricensis</i> Krug & Urb.	Taylor 11678 (MO)	—	AF243015 ⁴

Table 1. Continued.

Taxa	Voucher	GenBank accession number	
		<i>trnL-F</i>	<i>rps16</i>
<i>Rosenbergiodendron densiflorum</i> (K. Schum.) Fagerl.	Jansen-Jacobs et al. 3977 (GB)	AF201061 ¹	—
<i>Rosenbergiodendron densiflorum</i> (K. Schum.) Fagerl.	Gustafsson et al. 1994 (GB)	—	AF201014 ¹
<i>Rytigynia senegalensis</i> Blume	Madsen 6176	—	EU821637
<i>Scyphiphora hydrophyllacea</i> C. F. Gaertn.	Larsen 43134 (NY)	EU821648	EU821634
<i>Sipanea stahelii</i> Bremek.	Rova et al. 2068 (GB)	—	AF243023 ⁴
<i>Sipanea wilson-brownei</i> R. S. Cowan	Mori 25056 (NY)	EU821649	—
<i>Sipaneopsis rupicola</i> (Spruce ex K. Schum.) Steyerl.	Wurdack & Adde 43253 (NY)	AF152678 ³	—
<i>Stachyarrhena harleyi</i> J. H. Kirkbr.	Thomas 12032 (NY)	EU821650	—
<i>Stachyarrhena</i> sp.	Jansen-Jacobs et al. 4707 (GB)	—	AF201021 ¹
<i>Tarenna drummondii</i> Bridson	Delprete 7406 (NY)	AY555097 ²	EU821635
<i>Tocoyena williamsii</i> Standl.	Stahl 3028 (GB)	AF201071 ¹	—
<i>Tocoyena</i> Aubl. sp.	Jansen-Jacobs et al. 3976 (GB)	—	AF201016 ¹
<i>Vangueria madagascariensis</i> J. F. Gmel.	Delprete 7383 (NY)	AY555098 ²	EU821636

GenBank sequences were originally published in ¹Persson (2000b), ²Delprete & Cortés-B. (2004), ³Rova et al. (2002), ⁴Rova (unpublished), ⁵Struwe et al. (1998), ⁶Andersson & Rova (1999), and ⁷Piesschaert et al. (2000).

the bi-ovulated locules of *Retiniphyllum* were misinterpreted, resulting in its association with tribes currently placed in the subfamily Rubioideae. Hooker (1873) established the tribe Retiniphyllaeae to include *Retiniphyllum* and, by an incorrect interpretation of the fruit, the genus *Kutchubaea* Fisch. ex DC. In the classic system of classification proposed by Schumann (1891), the tribe Retiniphyllaeae was not recognized, and *Retiniphyllum* was placed in the tribe Gardenieae of the subfamily Cinchonoideae. Verdcourt (1958) recognized the tribe Retiniphyllaeae, and maintained it in the subfamily Cinchonoideae. Bremekamp (1966), who proposed one of the most important systems of classification for the Rubiaceae in the 20th century, criticized previous placements of *Retiniphyllum* and simply called it an “aberrant” genus. According to Bremekamp (1966), the absence of secondary pollen presentation, a defining character of the tribe Gardenieae and his subfamily Ixoroideae, was absent in *Retiniphyllum*. Robbrecht (1988, 1993) maintained *Retiniphyllum* in the tribe Retiniphyllaeae and placed it in the subfamily Antirheoideae, a subfamily that was not supported by molecular data (Bremer & Jansen, 1991; Bremer & Struwe, 1992; Bremer et al., 1995; Bremer, 1996; Rova, 1999; Rova et al., 2002). Andersson and Rova (1999), in their phylogenetic study that focused on the subfamily Rubioideae using *rps16*, sampled *Retiniphyllum* for the first time and placed it in the subfamily Ixoroideae. This placement was also supported by Rova (1999) and Rova et al. (2002) in their study of the Condamineae–Rondeletieae–Sipaneeae complex. In these analyses, *Retiniphyllum* was located in an isolated clade of the Ixoroideae related to Paletropical representatives, sister to a clade with members of the tribes Coffeae,

Gardenieae, Octotropideae, Pavetteae, Rondeletieae, and Vanguerieae. In the most recent Rubiaceae classification, the traditional Cinchonoideae and Ixoroideae were merged in a single subfamily, and the tribe Retiniphyllaeae was placed in the supertribe Ixoridinae of the subfamily Cinchonoideae (Robbrecht & Manen, 2006).

The genera *Botryarrhena* Ducke and *Scyphiphora* C. F. Gaertn. were tentatively included in the tribe Retiniphyllaeae by Robbrecht (1988). *Botryarrhena* comprises two species distributed in the Amazon Basin and Guayana Region. Ducke (1932) pointed out the resemblance of *Botryarrhena* to *Retiniphyllum* because they share bisexual flowers, terminal, racemose inflorescences, and two (rarely three or four) ovules per locule. On the other hand, the Asian genus *Scyphiphora* includes only *S. hydrophyllacea* C. F. Gaertn., the only mangrove species in the Rubiaceae. It has unique placentation with two ovules per locule, one of which is pendulous and the other erect. Robbrecht (1988) thought that this peculiar placentation is perhaps a form derived from the condition in *Retiniphyllum*.

The main goals of this study are to: (1) test the monophyly of the tribe Retiniphyllaeae, (2) evaluate the phylogenetic position of the Retiniphyllaeae within the subfamily Ixoroideae, and (3) evaluate the relationship of the genera *Botryarrhena* and *Scyphiphora* with *Retiniphyllum*.

METHODS

TAXON SAMPLING

A total of 49 taxa representing most tribes or groups recognized in the subfamily Ixoroideae s.l. were used

to test the monophyly of the Retiniphyllae: the Condamineae complex clade (Rova et al., 2002), Henriquezieae (Rogers, 1984), Posoquerieae (Delprete et al., 2004), Sipaneeae (Delprete & Cortés-B., 2004), Mussaendeae (Bremer & Tulin, 1998), Ixoreae (Andreasen & Bremer, 2000), Vanguerieae (Lantz et al., 2002), Octotropideae (Robbrecht, 1988), Coffeae, Pavetteae (Andreasen & Bremer, 2000), the *Alibertia* group (Persson, 2000a), and Gardenieae s.l. (Robbrecht, 1988).

In the phylogeny of *Retiniphyllum* (Cortés-B. et al., in prep.), most of the species are resolved in three main clades. In the present study, five representative species of *Retiniphyllum* were selected, including at least one from each clade: *R. concolor* (Spruce ex Benth.) Müll. Arg., *R. maguirei* Standl., *R. rhabdocalyx* Müll. Arg., *R. schomburgkii* (Benth.) Müll. Arg., and *R. secundiflorum* Bonpl.

Leaf samples were collected in the Botanical Gardens of Bruxelles (BR), Leiden (L), and Wageningen (W) by the second author, or obtained from herbarium material. We used chloroplast DNA (cpDNA) sequences of the *trnL-F* intergenic spacer and the *rps16* intron. Of the total number of sequences used in the analyses, 41% were original; the rest were downloaded from GenBank from Persson (2000b) [22%], Delprete and Cortés-B. (2004) [20%], and Rova et al. (2002) [9%], and the remaining 8% from Rova (unpublished), Struwe et al. (1998), Andersson and Rova (1999), and Piesschaert et al. (2000). Voucher information is presented in Table 1.

OUTGROUP SELECTION

Four members of the subfamilies Rubioideae and Cinchonoideae were selected as outgroup. *Psychotria* L. and *Amphidasya* Standl. have been shown to be part of the subfamily Rubioideae (Bremer & Manen, 2000; Rova et al., 2002), while *Cinchona* L. and *Rondeletia* L. are members of the subfamily Cinchonoideae (Bremer & Thulin, 1998; Rova et al., 2002).

DNA EXTRACTION, AMPLIFICATION, AND SEQUENCING

Total genomic DNA was isolated from approximately 1 cm² of dried leaf tissue desiccated in silica gel, or from herbarium material, using a modified CTAB methodology (Motley et al., 2005).

DNA was amplified using the polymerase chain reaction (PCR) following Motley et al. (2005). For amplification of the *trnL-F* spacer, the primers "e" (5'-GGTCAAGTCCCTCTATCCC-3') and "f" (5'-ATTTGAACTGGTGACACGAG-3') of Taberlet et al. (1991) were used. The *rps16* intron was amplified using the primers *rpsF* (5'-GTGGTAGAAAG-

CAACGTGCGACTT-3') and *rpsR2* (5'-TCGGGATC-GAACATCAATTGCAAC-3') designed by Oxelman et al. (1997). The PCR conditions were: hold 94°C for 3 min., 32 cycles of 94°C for 45 sec., 52°C for 30 sec., 72°C for 1 min. 30 sec., and hold 74°C for 7 min., hold 4°C. Cross-contamination was controlled by using negative controls in the PCR reactions. In addition, DNA from two individuals per species was extracted, amplified, and sequenced, when possible. Amplified products were purified with spin columns from the QIAquick PCR purification kit (Qiagen, Valencia, California, U.S.A.) following protocols provided by the manufacturer. Cycle sequencing conditions, gene cleaning using hydrated Sephadex G-50 DNA Grade F columns (Amersham Pharmacia Biotech Inc., Piscataway, New Jersey, U.S.A.), and the visualization separation of fragments were run on an ABI Prism 377 DNA sequencer (Applied Biosystems, Foster City, California, U.S.A.) following the protocols described in Motley et al. (2005).

PHYLOGENETIC ANALYSIS

The sequences were first edited in Sequencher 3.1.2 (Gene Codes Corporation, Ann Arbor, Michigan, U.S.A.) and preliminarily aligned with ClustalX (Thompson et al., 1997) using the default settings. They were then manually edited using BioEdit (Hall, 1999).

Parsimony analyses with equal character weights and unordered characters were performed with NONA (Goloboff, 1993) in concert with WinClada (Nixon, 2002). In the analyses, gaps were treated as missing values. Five heuristic searches were performed holding a maximum of 100,000 trees per search. In each search, 500 replications were carried out, keeping five trees per replication under the option mult*max*. The trees obtained were used to calculate a strict consensus tree. In order to evaluate the relative support of the clades, bootstrap (BS) and jackknife (JK) analyses were executed using 1000 replicates.

RESULTS

The combined analysis of the *trnL-F* and *rps16* data matrices had a total of 52 taxa and 1428 characters, 282 of which were parsimony informative. The heuristic search resulted in 54 most parsimonious trees of 651 steps in length, with a consistency index (CI) of 0.61 (when excluding uninformative characters) and a retention index (RI) of 0.82. Figure 1 shows the strict consensus tree obtained in the heuristic search with BS and JK support values.

In the strict consensus tree resulting from the maximum parsimony analysis, a well-supported clade

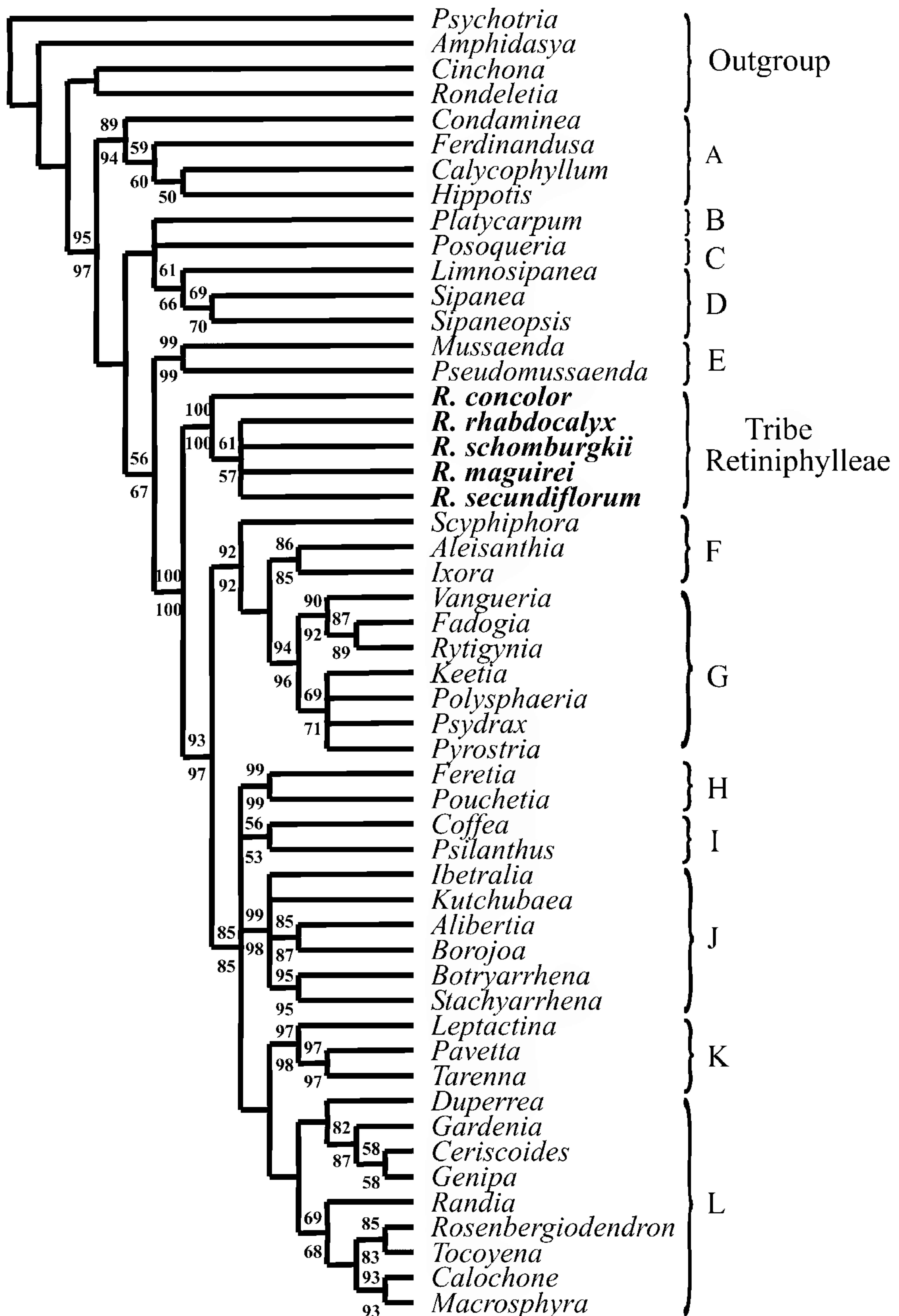

Figure 1. Strict consensus tree of the 54 most parsimonious trees from the combined *trnL-F* and *rps16* analysis. —A. Condamineae complex clade (Rova et al., 2002). —B. Henriquezieae (Rogers, 1984). —C. Posoquerieae (Delprete et al., 2004). —D. Sipaneeae (Delprete & Cortés-B., 2004). —E. Mussaendeae (Bremer & Thulin, 1998). —F. Ixoreae (Andreasen & Bremer, 2000). —G. Vanguerieae (Lantz et al., 2002). —H. Octotropideae (Robbrecht, 1988). —I. Coffeae. —J. *Alibertia* group (Persson, 2000a). —K. Pavetteae (Andreasen & Bremer, 2000). —L. Gardenieae s.l. (Robbrecht, 1988). Bootstrap (BS) and jackknife (JK) support values are indicated above and below branches, respectively.

(BS – 89%, JK – 94%) was retrieved containing genera *Condaminea* DC., *Ferdinandusa* Pohl, *Calycophyllum* DC., and *Hippotis* Ruiz & Pav., which had been placed in the subfamily Cinchonoideae in previous systems of classification (Verdcourt, 1958; Bremekamp, 1966; Robbrecht, 1988, 1993). This clade was sister to the rest of the sampled genera. Members of the tribes Sipaneeae, Henriquezieae, and Posoquerieae are together in an unsupported clade sister to the members of the tribe Mussaendeae (BS = 56%, JK – 67%) and the clade that includes *Retiniphyllum* species. All the species sampled of *Retiniphyllum* are together in a strongly supported clade (BS – 100%, JK – 100%), sister to a clade that includes Ixoreae, Vanguerieae, Octotropideae, Coffeae, Pavetteae, *Alibertia* group, and Gardenieae s.l.

DISCUSSION

THE MONOPHYLY AND POSITION OF THE TRIBE RETINIPHYLLEAE IN THE SUBFAMILY IXOROIDEAE

Because species of *Retiniphyllum* formed a strongly supported monophyletic lineage (BS – 100%, JK – 100%) in the independent (not shown) and combined chloroplast analyses (Fig. 1), the monophyly of the genus *Retiniphyllum* is confirmed. Similarly, the isolated position of *Retiniphyllum* in the cladogram also confirms the monophyly of the tribe Retiniphyllae.

The tribe Retiniphyllae is placed as a clade within the subfamily Ixoroideae s.l., sister to the tribes that correspond for the most part to the Ixoroideae sensu Bremekamp (Bremekamp, 1966). Although the systematics of the subfamily Ixoroideae have been largely modified since Bremekamp's proposal, his tribes Gardenieae, Ixoreae, and Vanguerieae correspond to the core of the Ixoroideae in its original circumscription. The results presented here also support those previously reported by Rova (1999) and Rova et al. (2002).

Robbrecht (1988) included the tribes Retiniphyllae and Vanguerieae in the subfamily Antirheoideae, suggesting that morphological similarities of their fruits and seeds supported this relationship. In addition, Robbrecht and Manen (2006) considered that these similarities were consistent with their placement in their supertribe Ixoridae. According to our results, the tribe Retiniphyllae is not closely related to the Vanguerieae.

THE PLACEMENT OF *BOTRYARRHENA*

Botryarrhena was resolved within the *Alibertia* group, sister to *Stachyarrhena* Hook. f. in a clade with the genera *Ibetrulia* Bremek., *Kutchubaea*,

Alibertia A. Rich. ex DC., and *Borojoa* Cuatrec. (Fig. 1).

Ducke (1932) suggested an affinity between the genera *Botryarrhena* and *Stachyarrhena*. They share racemose inflorescences, but differ because *Stachyarrhena* has unisexual flowers and a dioecious breeding system (Ducke, 1932). *Stachyarrhena* is now placed within the *Alibertia* group, a clade within the tribe Gardenieae (Persson 2000a, b). Subsequently, unisexual flowers have been observed in *Botryarrhena* (Persson & Delprete, pers. comm.), providing further support for the placement of *Botryarrhena* in this lineage.

The relationship between *Botryarrhena* and *Retiniphyllum* suggested by Ducke (1932) was based on flower sexuality, inflorescence morphology, and number of ovules per locule. However, it is important to note that Standley was not able to see the berry-like fruits of *Botryarrhena*, a common fruit type of many genera in the Ixoroideae but not in *Retiniphyllum*.

THE PLACEMENT OF *SCYPHIPHORA*

According to our results, the genera *Retiniphyllum* and *Scyphiphora* are resolved in two distinct clades, indicating that the bi-ovulate condition has evolved independently in the subfamily.

Puff and Rohrhofer (1993) studied the morphology of *Scyphiphora* in detail and found no characters suggesting a close relationship to *Retiniphyllum*. They tentatively placed *Scyphiphora* in the subtribe Diplosporinae, tribe Gardenieae s.l., based on the presence of tracheidal idioblasts in *Scyphiphora*, which are similar to the mesophyll sclereids in the Gardenieae. Andreasen and Bremer (2000), using morphological and molecular data, placed *Scyphiphora* as sister to the tribe Ixoreae, and they tentatively included it in the Ixoreae.

Our results indicate that *Scyphiphora* is sister to a clade that includes the tribe Ixoreae and also Vanguerieae (Fig. 1). This indicates that *Scyphiphora* is neither a member of the tribe Gardenieae s.l. as Puff and Rohrhofer (1993) suggested, nor a member of the tribe Ixoreae as Andreasen and Bremer (2000) hypothesized.

Literature Cited

- Andersson, L. & J. H. E. Rova. 1999. The *rps16* intron and the phylogeny of the Rubioideae (Rubiaceae). *Pl. Syst. Evol.* 214: 161–186.
- Andreasen, K. & B. Bremer. 2000. Combined analysis in the Rubiaceae–Ixoroideae: Morphology, nuclear and chloroplast DNA data. *Amer. J. Bot.* 87: 1731–1748.
- Bentham, G. 1841. Contributions towards a Flora of South America—Enumeration of plants collected by Mr. Schomburgk in British Guiana. *J. Bot. (Hooker)* 3: 212–250.

- Bremekamp, C. E. B. 1966. Remarks on the position, the delimitation, and the subdivision of the Rubiaceae. *Acta Bot. Neerl.* 15: 1–33.
- Bremer, B. 1996. Phylogenetic studies within Rubiaceae and relationships to other families based on molecular data. *Opera Bot. Belg.* 7: 33–50.
- & R. K. Jansen. 1991. Comparative restriction site mapping of the chloroplast DNA implies new phylogenetic relationships within the Rubiaceae. *Amer. J. Bot.* 78: 198–213.
- & L. Struwe. 1992. Phylogeny of the Rubiaceae and the Loganiaceae: Congruence or conflict between morphological and molecular data? *Amer. J. Bot.* 79: 1171–1184.
- & M. Thulin. 1998. Collapse of Isertieae, re-establishment of Mussaendeae, and a new genus of Sabiceae (Rubiaceae); phylogenetic relationships based on *rbcL* data. *Pl. Syst. Evol.* 211: 71–92.
- & J. F. Manen. 2000. Phylogeny and classification of the subfamily Rubioideae (Rubiaceae). *Pl. Syst. Evol.* 225: 47–72.
- , K. Andreasen & D. Olsson. 1995. Subfamilial and tribal relationships in the Rubiaceae based on *rbcL* sequence data. *Ann. Missouri Bot. Gard.* 82: 383–397.
- Candolle, A. P. de. 1830. Rubiaceae. *Prodromus Systematis Naturalis Regni Vegetabilis*, Vol. 4: 341–362. Treuttel & Würtz, Paris.
- Delprete, P. G. & R. Cortés-B. 2004. A preliminary phylogenetic study of the tribe Sipaneeae (Rubiaceae, Ixoroideae), using *trnL-F* and ITS sequence data. *Taxon* 53: 347–356.
- , L. B. Smith & R. B. Klein. 2004. Rubiaceae, 1. *Alseis* até 19. *Galium*. Pp. 1–344 in A. Reis (editor), *Flora Ilustrada Catarinense*, Vol. 1: Gêneros de A–G. Herbario Barbosa Rodrigues, Itajaí, Santa Catarina, Brazil.
- Ducke, A. 1932. Neue Arten aus der *Hyalea* Brasiliens. *Notizbl. Bot. Gard.* 11: 471–483.
- Goloboff, P. A. 1993. NONA version 2.0. Program and documentation distributed by the author, Tucumán, Argentina.
- Hall, T. A. 1999. BioEdit: A user-friendly biological sequence alignment editor and analysis program for Windows 95/98/NT. *Nucl. Acids Symp. Ser.* 41: 95–98.
- Hooker, J. D. 1873. Ordo LXXXIV. Rubiaceae. Pp. 7–151 in G. Bentham & J. D. Hooker (editors), *Genera Plantarum*, Vol. 2. Lovell Reeve & Co., London.
- Jussieu, A. L. de. 1820. Sur la famille des plantes Rubiacées. *Mém. Mus. Hist. Nat.* 6: 365–410.
- Kunth, C. S. 1818. *Retiniphyllum*. Pp. 421–422 in F. H. A. Humboldt & A. J. de Bonpland (editors), *Nova genera et species plantarum*, *Librariae graeco-latini-germanicae*, Paris.
- Lantz, H., K. Andreasen & B. Bremer. 2002. Nuclear rDNA ITS sequence data used to construct the first phylogeny of Vanguerieae (Rubiaceae). *Pl. Syst. Evol.* 230: 173–187.
- Motley, T. J., K. J. Wurdack & P. G. Delprete. 2005. Molecular systematics of the Chiococceae–Catesbaeae Complex (Rubiaceae): Flower and fruit evolution and systematic implications. *Amer. J. Bot.* 92: 316–329.
- Nixon, K. C. 2002. WinClada Vers. 1.00.08. Published by the author, Ithaca, New York.
- Oxelmann, B., M. Lidén & D. Berglund. 1997. Chloroplast *rps16* intron phylogeny of the tribe Sileneae (Caryophyllaceae). *Pl. Syst. Evol.* 206: 393–410.
- Persson, C. 2000a. Phylogeny of the Neotropical *Alibertia* group (Rubiaceae), with emphasis on the genus *Alibertia*, inferred from ITS and 5S ribosomal DNA sequences. *Amer. J. Bot.* 87: 1018–1028.
- . 2000b. Phylogeny of Gardenieae (Rubiaceae) based on chloroplast DNA sequences from the *rps16* intron and *trnL(UAA)-F(GAA)* intergenic spacer. *Nord. J. Bot.* 20: 257–269.
- Piesschaert, F., L. Andersson, S. Jansen, S. Dessein, E. Robbrecht & E. Smets. 2000. Searching for the taxonomic position of the African genus *Colletocema* (Rubiaceae): Morphology and anatomy compared to an *rps16*-intron analysis of the Rubioideae. *Canad. J. Bot.* 78: 288–304.
- Puff, C. & U. Rohrhofer. 1993. The character states and taxonomic position of the monotypic mangrove genus *Scyphiphora* (Rubiaceae). *Opera Bot. Belg.* 6: 143–172.
- Richard, A. 1830. Mémoire sur la famille des Rubiacées. Imprimerie de J. Tatsu, Paris. (Reimpr. *Mém. Soc. Hist. Nat. Paris*, ser. 3 5: 81–224. 1834).
- Robbrecht, E. 1988. Tropical Woody Rubiaceae. *Opera Bot. Belg.* 1: 1–271.
- . 1993 [1994]. Supplement to the 1988 outline of the classification of the Rubiaceae. Index to genera. Pp. 173–196, in E. Robbrecht (editor), *Advances in Rubiaceae Macro-systematics*. *Opera Bot. Belg.* Vol. 6.
- Richard, A. & J. F. Manen. 2006. The major evolutionary lineages of the coffee family (Rubiaceae, angiosperms). Combined analysis (nDNA and cpDNA) to infer the position of *Coptosapelta* and *Luculia*, and supertree construction based on *rbcL*, *rps16*, *trnL-trnF*, and *atpB-rbcL* data. A new classification in two subfamilies, Cinchonoideae and Rubioideae. *Syst. Geogr. Pl.* 76: 85–146.
- Roemer, J. J. & J. A. Schultes. 1818. *Systema vegetabilium* 3: 255. J. G. Cottae, Stuttgart.
- Rogers, G. K. 1984. *Gleasonia*, *Henriquezia*, and *Platycarpum* (Rubiaceae). *Fl. Neotrop. Monogr.* 39: 1–135.
- Rova, J. H. E. 1999. The Rondeletieae–Condamineae–Sipaneeae Complex (Rubiaceae). Ph.D. Dissertation, University of Göteborg, Göteborg, Sweden.
- , P. G. Delprete, L. Andersson & V. A. Albert. 2002. A *trnL-F* cpDNA sequence study of the Condamineae–Rondeletieae–Sipaneeae complex with implications on the phylogeny of the Rubiaceae. *Amer. J. Bot.* 89: 145–159.
- Schumann, K. 1891. Rubiaceae. Pp. 1–156 in A. Engler & K. Prantl (editors), *Die natürlichen Pflanzenfamilien*, Vol. 4(4). Engelmann, Leipzig.
- Struwe, L., M. Thiv, J. W. Kadereit, A. R. Pepper, T. J. Motley, P. J. White, J. H. E. Rova, K. Potgieter & V. A. Albert. 1998. *Saccifolium* (Saccifoliaceae), an endemic of Sierra de la Neblina on the Brazilian-Venezuelan border, is related to a temperate-alpine lineage of Gentianaceae. *Harvard Pap. Bot.* 3: 199–214.
- Taberlet, P., L. Gielly, G. Patou & J. Bouvet. 1991. Universal primers for amplification of three non-coding regions of chloroplast DNA. *Pl. Molec. Biol.* 17: 1105–1109.
- Thompson, J. D., T. J. Gibson, F. Plewniak, F. Jeanmougin & D. G. Higgins. 1997. The Clustal X Windows interface: Flexible strategies for multiple sequence alignment aided by quality analysis tools. *Nucl. Acids Res.* 24: 4876–4882.
- Verdcourt, B. 1958. Remarks on the classification of the Rubiaceae. *Bull. Jard. Bot. État Bruxelles* 28: 209–281.

A GLOBAL ASSESSMENT OF DISTRIBUTION, DIVERSITY, ENDEMISM, AND TAXONOMIC EFFORT IN THE RUBIACEAE¹

Aaron P. Davis,² Rafaël Govaerts,²
Diane M. Bridson,² Markus Ruhsam,³
Justin Moat,² and Neil A. Brummitt²

ABSTRACT

Analyses of distribution, diversity, endemism, and taxonomic effort for Rubiaceae are reported, based on queries from a World Rubiaceae Checklist database. Rubiaceae are widespread and occur in all major regions of the world except the Antarctic Continent, but are predominantly a group in the tropics with greatest diversity in low- to mid-altitude humid forests. A count of Rubiaceae species and genera is given (13,143 spp./611 genera), which confirms that this is the fourth largest angiosperm family. *Psychotria* L. is the largest genus in the Rubiaceae (1834 spp.) and the third largest angiosperm genus. Most genera (72%) have fewer than 10 species and 211 are monotypic. Calculation of relative species diversity and percentage endemism enables areas of high diversity and endemism to be enumerated, and identifies areas where further field collecting and taxonomic research are required. Endemism is generally high in Rubiaceae, which supports data from recent studies showing that many species have restricted distributions. Given the assumed ecologic sensitivity of Rubiaceae, in combination with a range of other factors including restricted distribution, we suggest that species in this family are particularly vulnerable to extinction. The rate at which new species are being described is inadequate; more resources are required before the diversity of Rubiaceae is satisfactorily enumerated.

Key words: Biodiversity, coffee family, conservation, endemics, endemism, Rubiaceae, species diversity, taxonomic databases, Taxonomic Databases Working Group (TDWG), taxonomy.

Target One of the *Global Strategy for Plant Conservation* (Secretariat of the Convention on Biological Diversity, 2002) is the production of “a widely accessible working list of known plant species, as a step towards a complete world flora,” which is a fundamental requirement for plant conservation (Nic Lughadha, 2004). For some of the largest flowering plant families and for larger groups (i.e., monocotyledons), several important works have been completed that significantly improve our prospects for achieving Target One. For example, information on Euphorbiaceae (Govaerts et al., 2000; <<http://www.kew.org/wcsp/malpighiales/>>) is available in print and on the Internet, and for monocotyledons, information is accessible only via the Internet (e.g., Govaerts, 2006; <<http://www.kew.org/wcsp/monocots/>>), as part of the World Checklist Series (<<http://www.kew.org/wcsp/>>). In the Internet-only category, a species checklist for the Rubiaceae has recently become available (Govaerts et al., 2006; <<http://www.kew.org/wcsp/rubiaceae/>>). This work, like others in the series, represents an amalgamation and synthesis of taxonomic work.

These checklists are valuable as widely accessible working lists of accepted plant species, but they also enable broad-scale analysis of distribution and diversity to be undertaken (e.g., Cribb & Govaerts, 2005). As these checklists are taxonomically complete and also include distributions for each accepted species, they provide an interesting counterpoint to more detailed but less complete compilations on plant species diversity that have been recently published (Barthlott et al., 1996, 1999; Kier et al., 2005; Mutke & Barthlott, 2005). These publications have produced impressively precise maps of global plant species diversity, generally modeled from available species lists for different parts of the world (Barthlott et al., 1996, 1999; Kier et al., 2005), but often without having complete species distributions to underpin the estimates of diversity. Herein, we use queries from the World Checklist of Rubiaceae (Govaerts et al., 2006; <<http://www.kew.org/wcsp/rubiaceae/>>) to analyze the distribution, diversity, endemism, and taxonomic effort for Rubiaceae. This represents the first such analysis of the whole family and follows recent work

¹ We are grateful to the curators of L and P for making specimens available for study. The Global Biodiversity Information Facility (GBIF), within the Electronic Catalogue of Names of Known Organisms (ECAT) program, supported part of the work undertaken for this contribution. At Kew, we would like to thank D. Zappi for anecdotal information concerning the Rubiaceae of tropical South America, and S. Dawson and M. Briggs for assistance in the preparation of this paper.

² Herbarium, Royal Botanic Gardens, Kew, Richmond, Surrey, TW9 3AE, United Kingdom. a.davis@kew.org.

³ University of Edinburgh, Institute of Evolutionary Biology, Ashworth Laboratories, West Main Road, Edinburgh, EH9 3JT, United Kingdom.

doi: 10.3417/2006205

on a global analysis of plant genus distributions (Brummitt, 2005).

Rubiaceae is a member of the Gentianales and shares many of the features common to other families of the order, particularly basic leaf and floral morphology (Davis & Bridson, 2007; and see below), the presence of colleters, and lack of internal phloem. It is the fourth largest flowering plant family and is estimated to contain around 600 genera and between 6000 and 13,000 species (see below). It is usually easy to identify by the presence of simple, opposite or whorled, entire leaves, interpetiolar stipules, and an inferior ovary. Rubiaceae has a cosmopolitan distribution, but species diversity and biomass are distinctly concentrated in the tropics and the subtropics and especially in lowland humid forest, where it is often the most species-abundant woody plant family. The family is less frequent and less diverse but still very widespread in the temperate regions. It is also found in the subpolar regions of the Arctic and Antarctic (Davis & Bridson, 2007). In the tropical regions, Rubiaceae species are sensitive to disturbance and are rarely found in secondary forest types (A. Davis & D. Bridson, pers. obs.; Davis et al., 2006; Sohmer & Davis, 2007). Most Rubiaceae species are small trees or shrubs, but nearly all life-forms are found, including large trees, annual and perennial herbaceous plants, woody monocaul dwarfs, lianas, epiphytes, geofrutices (more or less herbaceous stems with a woody rootstock), myrmecophiles (hollow stems or special chambered tubers, containing ants or ant colonies), and rarely succulent or aquatic life-forms (Robbrecht, 1988; Davis & Bridson, 2007). Rubiaceae includes coffee (*Coffea* L.), which is by far the most important economic plant within the family and the world's most important commodity after oil (Vega et al., 2003).

METHODS

DATABASE

The production of the World Checklist of Rubiaceae was made from a database encompassing 24 fields, including basic nomenclatural data (genus, species, author, place and data of publication, basionym [if applicable], synonyms [if applicable], and accepted name), distribution data, and life-form. The World Checklist of Rubiaceae (Govaerts et al., 2006) does not include altitude data. Altitude does have a bearing on occurrence and diversity; long-standing knowledge of the family (D. Bridson & A. Davis, pers. obs.) indicates that Rubiaceae species diversity is higher at low to mid-altitudes, with most of the diversity occurring at altitudes of less than

1500 m. The data comply with the data standards proposed by the International Organization for Plant Information (IOPI) (Burnett, 1994), in association with the Taxonomic Databases Working Group (TDWG) (Brummitt et al., 2001). Citation of authors follows Brummitt and Powell (1992); book titles are abbreviated according to Stafleu and Cowan (1976–1988) and Stafleu and Mennega (1992–2000); periodicals are abbreviated according to Bridson and Smith (1991); and the number and three-letter codes used for areas (e.g., 23 CON) follow the TDWG system. Compilation of the database was undertaken using FoxBASE (Microsoft, Redmond, Washington, U.S.A.), a dBASE-class database program for personal computers. The database was founded on the Index Kewensis database, held at the Royal Botanic Gardens, Kew (K). The selection of accepted names and the designation of synonyms were made on the basis of published or otherwise publicly available taxonomic works. Further taxonomic input and accuracy were achieved by: (1) specialist taxonomic review; (2) a complete herbarium survey of the Rubiaceae collections held at K; and (3) a survey of selected parts of the collections housed at L and P (abbreviations from Holmgren et al., 1990). Data collection for procedures (2) and (3) mainly used herbarium specimens cited in taxonomic revisions or identified by specialists; these procedures added a further 2500 geographic records to the World Checklist of Rubiaceae database at TDWG Level 3.

STANDARDIZING RUBIACEAE DIVERSITY FOR DIFFERENT-SIZED AREAS

Counts of taxa for both species and genera for all areas at TDWG Level 3 (369 areas) were extracted from the World Checklist of Rubiaceae (Govaerts et al., 2006). The TDWG World Geographical Scheme for Recording Plant Distributions is based on geopolitical units, which vary widely in size from the Antarctic Continent to tiny oceanic islands. In order to make counts of species and genera comparable between these units, the counts were rescaled to make them independent of area. However, the diversity of a region cannot be simply divided by the size of that region to give a value comparable with other differently sized regions because the relationship between diversity and area is a nonlinear, power-law relationship (Rosenzweig, 1995). Dividing by area overinflates the diversity of small regions and underestimates the diversity of large regions (Brummitt & Nic Lughadha, 2003). Instead, the power-law relationship $S = cA^z$ (where S = number of species, A = area, and c and z represent, respectively, the intercept and the slope of the regression in a log-log

space) can be rewritten as $c = S/A^z$ to give a value for each region that is independent of area (Rosenzweig, 1995). This value is then standardized to a size appropriate for the range of areas being studied, again using the exponent value z .

An important consideration is the exact value of the exponent used to rescale diversity figures. Although small changes in z values do not give very different results (results not shown here), they can nevertheless influence the relative positions of regions close together in size or diversity (i.e., more or less diverse regions might move up or down the list of most diverse areas relative to other regions). The z value is known to vary between different regions, being lower for large, continental regions and higher for small, oceanic regions (Rosenzweig, 1995). For this study, z values appropriate to each region in question could be estimated from the previous study by Kier et al. (2005), which empirically determined z values for each of the 14 biomes of the World Wildlife Fund (WWF) ecoregions (Olson et al., 2001) from smaller-scale studies within each biome. A spatial overlay was used between the TDWG Level 3 areas and the WWF ecoregions, and the mean z value for TDWG regions was calculated with a weighted average by area of the intersection between each TDWG level and the WWF ecoregions.

In this study, the intercept values of relative diversity were standardized to a size of 10,000 km², roughly the median size of TDWG Level 3 areas, similar to and facilitating comparison with the work by Barthlott et al. (1996, 1999) (Brummitt et al., unpublished). The values resulting from the rescaling of species numbers in this way ($S/10000$) do not reflect actual numbers of taxa, but they do allow relative diversities to be compared for different regions that are independent of the size of that region. In this contribution, only the first 20 records for each database query/analysis are given. Complete results for all 369 TDWG Level 3 areas are available from the authors upon request.

RESULTS AND DISCUSSION

THE NUMBER OF GENERA AND SPECIES IN RUBIACEAE

Recent estimates as to the number of Rubiaceae species and genera are quite constant, apart from the estimates of species numbers by Verdcourt (1976, 1989) and Smith (1988). Estimates are as follows: Verdcourt (1976, 1989), 500 genera and 6000 spp.; Smith (1988), 500 genera and 6500–7000 spp.; Mabberley (1987), 630 genera and 10,400 spp.; Mabberley (1997), 650 genera and 10,200 spp.; Robbrecht (1988), 637 genera and 10,700 spp.; and Brummitt (1992), 606 genera.

According to the World Checklist of Rubiaceae database, the number of accepted Rubiaceae species is 13,143 in 611 genera. Given the rate at which species have been added to Rubiaceae over the past 30 years or so (see below), and assuming that more synonyms have been created than retrieved from synonymy, all previous estimates for species number are much lower than the actual figures would have been at that time, apart from estimates by Bridson and Verdcourt (2003: 650 genera and 13,000 spp.) and Davis and Bridson (2007: 615 genera and 13,150 spp.), which were based on earlier versions of the data used here. This is particularly so for estimates in the 6000–7000 range (which are roughly half of the actual figures for species number presented here). In general, the species diversity for Rubiaceae has been considerably (Verdcourt, 1976, 1989; Smith, 1988) to moderately (e.g., Robbrecht, 1988) underestimated. This is no doubt due to the difficulties in estimating species numbers in large families, particularly where the total number of published names is often considerable. The World Checklist of Rubiaceae database holds a total of 36,385 published names, for example (Govaerts et al., 2006). Estimates as to the number of genera have been quite accurate, mostly because the number of names involved is much lower and presumably also due to the presence of generic indices and similar resources that exist in herbaria and libraries.

At 13,143 species, Rubiaceae is the fourth largest angiosperm family (Robbrecht, 1988) after Orchidaceae (25,158 spp., ca. 830 genera; Cribb & Govaerts, 2005), Asteraceae (23,000–30,000 spp., 1535–1700 genera; Bremer, 1994; Funk et al., 2005), and Leguminosae (19,350 spp.; 727 genera; Lewis et al., 2005); Poaceae is the fifth largest (ca. 11,591 spp., ca. 700 genera; Govaerts, 2006). The numbers for Asteraceae and Leguminosae have been estimated and are not based on definitive counts of accepted species, although Leguminosae has been carefully calculated (Lewis et al., 2005). Parenthetically, of the five largest families, Orchidaceae, Poaceae, and Asteraceae are herbaceous or predominantly so. Leguminosae, like Rubiaceae, includes a mix of woody and herbaceous taxa, although Leguminosae has a greater proportion of herbaceous species. Nic Lughadha et al. (2005) posits that Leguminosae is the most representative family for angiosperm diversity patterns. Rubiaceae is particularly well represented in humid tropical forests and, when coupled with Asteraceae in a global analysis of angiosperm diversity, is shown to comprise one of the most representative pairs of families at species level (N. Brummitt, unpublished).

As with most other flowering plant families, the number of accepted Rubiaceae species is still

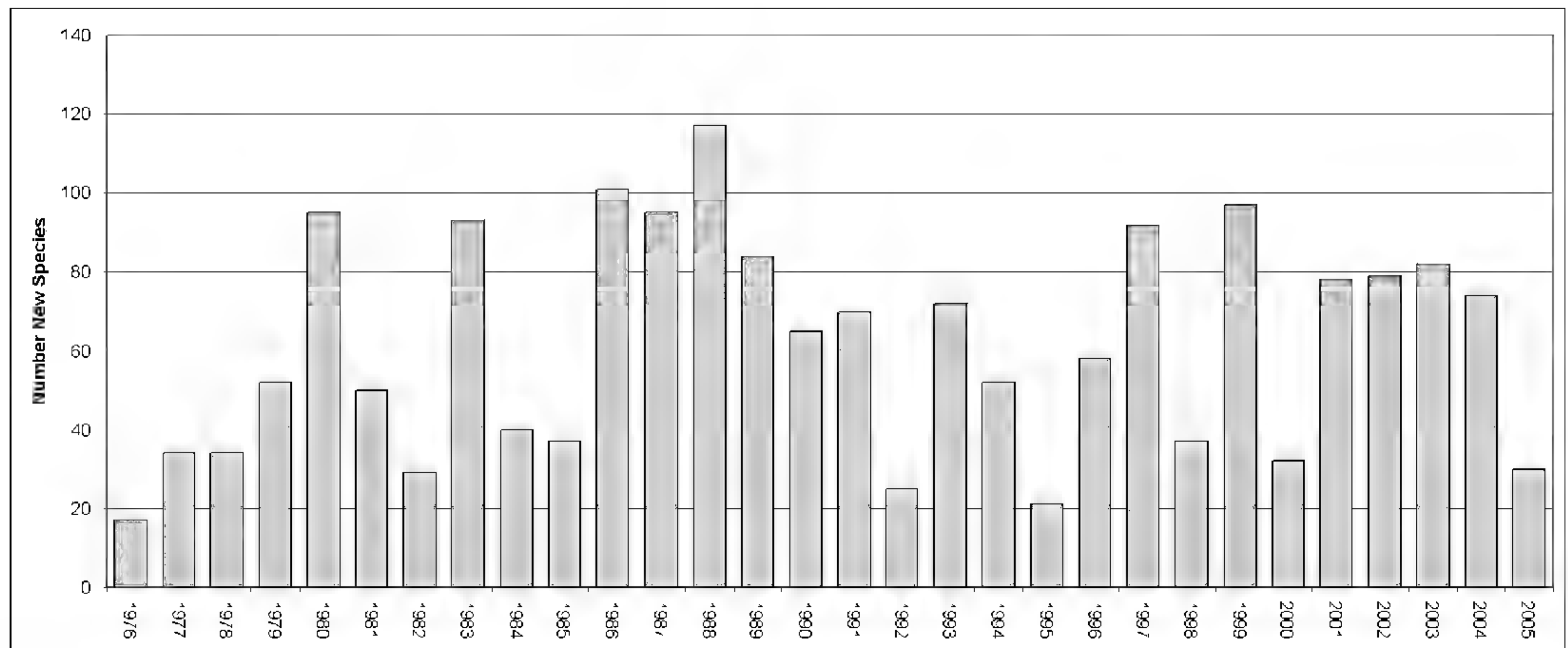

Figure 1. Number of new Rubiaceae species published each year from 1976–2005.

increasing, year by year, and the final number will be greater than it is today. The total number of Rubiaceae species is estimated at ca. 16,000 (A. Davis, M. Ruhsam & D. Zappi, unpublished), based on a review of herbarium collections (K, P, and L) and an awareness of undescribed species (from databases, literature, fieldwork, and anecdotal evidence). The 2800 or so species required to make a total of 16,000 take into account potential synonymy and may be broken down in the following manner: unplaced names brought into accepted usage (500); undescribed species from tropical South America (500), tropical Africa (400), Madagascar (300; Davis & Bridson, 2003), southern Asia (300), Malesia (500), Australia and the Pacific (100), and other regions (100). There are ca. 1000 unplaced names on the World Checklist of Rubiaceae (Govaerts et al., 2006), and we estimate that nomenclatural and taxonomic work will see at least 500 species added to the current species count from this source alone (Ruhsam et al., 2008).

From 1976–2005, 1842 Rubiaceae species names have been validly published (Fig. 1), which gives an average of 63.5 species per year for this period. The minimum number of species published since 1976 was 17 (in 1976) and the maximum 117 (in 1988). The average for this period does not give us the figure for the increase in accepted names, as the number of synonyms created per year is not included in the above calculations. In fact, it is very difficult to quantify the number of names placed in synonymy per year, as it is not recorded. If we extrapolate by looking at the total number of validly published names produced since the starting date for formal biological nomenclature (1753), over a 252-year period from 1753–2005, the average is 52 species per year, and this gives us some idea of increase of accepted names

per year. The number of new (validly published) genera added over the same 30-year period is 104, making an average of 3.5 genera per year. The maximum number of genera published during this period was 12 (1978) and the minimum was 0 (1976, 1977, 1991, 1992, 2002). If we extrapolate in the same way as we did for species, in order to get some idea of gross increase in new genera per year, the average is 2.4 since 1753. As with the species calculation, the figures for the 30- and 252-year period are not that different. Based on the same evidence as for species (herbarium data, anecdotal evidence, fieldwork, etc.), and taking into account our assumption that estimates for genera are more accurate than those for species, the number of genera is not likely to increase significantly.

Taxonomic effort at the species level for Rubiaceae, as estimated above, is probably much lower than that of most other large plant families (i.e., those with more than 10,000 species), although Orchidaceae is the only other large plant family for which accurate figures are available for comparative purposes. In Orchidaceae, from 1978–2002, the average number of newly described orchid species was over 280 per year, with the number surpassing 500 (per year) twice during this period (Cribb & Govaerts, 2005). Even considering the special interest given to orchids, and the fact that Orchidaceae has approximately twice the number of species of Rubiaceae, taxonomic effort for Rubiaceae is considerably lower. Based on our estimate that there are actually around 16,000 species of Rubiaceae (i.e., 2800 species still requiring scientific names), it will take around 45 years before the species diversity in the family is satisfactorily enumerated, if we continue to describe species at the current rate (see above).

SIZE OF GENERA

The 20 largest genera of the Rubiaceae are listed in Table 1. Despite recent discussions and actions concerning delimitation (Taylor, 1996, 2001; Nepokroeff et al., 1999; Davis et al., 2001; Andersson, 2002), *Psychotria* L. is still the largest genus in Rubiaceae, with 1834 species. Recent publications (Sohmer & Davis, 2007; Davis et al., 2007; Ruhsam et al., 2008) will bring the total number of *Psychotria* species close to 2000, as estimated by Sohmer (1988) and Davis et al. (2001). *Psychotria* is now the world's third largest genus, after *Astragalus* L. (Leguminosae) with ca. 3200 species and *Bulbophyllum* Thouars (Orchidaceae) with ca. 2000 species (Frodin, 2004).

There are 30 Rubiaceae genera with over 100 species, but most contain fewer than 10 species. There are 211 monotypic genera (34.5% of genera; 1.6% of species), 328 genera with three species or fewer (53.7% of genera), and 440 genera with 10 species or fewer (72% of genera). Although all large taxonomic groups have a greater number of small taxa (Clayton, 1972, 1974; Cronk, 1989), the percentage of monotypic genera in Rubiaceae is higher than that in both Orchidaceae, with 211 monotypic genera out of 849 (Cribb & Govaerts, 2005) (24.9% of genera; 0.8% of species) or Leguminosae, with 192 monotypic genera out of 727 genera (Lewis et al., 2005) (26.4% of genera; 1% of species). Similar analyses of other large angiosperm families are needed to understand whether such a large number of monotypic genera in Rubiaceae is unusual, part of a natural phenomenon, or an artifact of our classification systems (Knapp et al., 2005). However, the fact that such strongly skewed frequency distributions are shown not just by taxon size but also by spatial distribution (many narrowly distributed taxa and few very widely distributed taxa) (Colwell & Lees, 2000; Gaston, 2003) and also temporal taxon distribution (many short-lived taxa and few very long-lived taxa) (Rosenzweig, 1995) suggests that this is a natural phenomenon.

In light of ongoing Rubiaceae research (De Block et al., 2006), it is evident that even over the next five years or so the size of many of the large genera will change quite considerably (in particular *Ixora* L., *Spermacoce* L., *Oldenlandia* L., *Tarenna* Gaertn., and *Canthium* Lam.), as their circumscriptions are altered in the light of new systematic data. Some genera will increase in size, owing to the necessary inclusion of other genera, most notably *Ixora*, whereas others will decrease in size, such as *Canthium* (Lantz & Bremer, 2004; Razafimandimbison et al., unpublished). Of the largest 20 Rubiaceae genera, only *Pavetta* L. (Bremekamp, 1934) has been monographed, and for

Table 1. The 20 largest (by species number) genera in Rubiaceae.

No.	Genus	No. of species
1	<i>Psychotria</i> L.	1834
2	<i>Galium</i> L.	621
3	<i>Ixora</i> L.	530
4	<i>Pavetta</i> L.	357
5	<i>Ophiorrhiza</i> L.	317
6	<i>Palicourea</i> Aubl.	313
7	<i>Rondeletia</i> L.	260
8	<i>Spermacoce</i> L.	257
9	<i>Oldenlandia</i> L.	249
10	<i>Lasianthus</i> Jack	228
11	<i>Faramea</i> Aubl.	208
12	<i>Tarenna</i> Gaertn.	203
13	<i>Mussaenda</i> L.	200
14	<i>Asperula</i> L.	182
15	<i>Timonius</i> DC.	169
16	<i>Argostemma</i> Wall.	162
17	<i>Guettarda</i> L.	159
18	<i>Gardenia</i> Ellis	143
19	<i>Coussarea</i> Aubl.	133
20	<i>Canthium</i> Lam.	130

the largest 50 genera, there are only a few with complete taxonomic treatments, e.g., *Sabicea* Aubl. (Wernham, 1914), *Manettia* Mutis ex L. (Wernham, 1918–1919), *Coffea* (Chevalier, 1947), and *Leptodermis* Wall. (Winkler, 1922), although contemporary monographs are now needed for these four genera.

DISTRIBUTION OF RUBIACEAE

Rubiaceae occur in every region of the world (at TDWG Level 3), except for the Antarctic Continent, which only has two native vascular plant species (*Deschampsia antarctica* E. Desv. and *Colobanthus quitensis* (Kunth) Bartl.). Rubiaceae is a predominantly tropical family, with species diversity decreasing rapidly from the subtropics through the temperate regions to the poles. There are usually hundreds of species in each of the tropical TDWG Level 3 areas, tens in the temperate areas, and usually fewer than 10 in subarctic regions; the entire Subarctic America region (TDWG 70) has only eight *Galium* L. species, for example. There are, however, specific areas in the tropical belt that do not have high numbers of species or high species diversity for Rubiaceae (see below).

DISTRIBUTION OF SPECIES DIVERSITY

Table 2 gives the 20 most species-rich regions for Rubiaceae based on gross number of indigenous species for each TDWG Level 3 area. This makes a useful comparison between TDWG Level 3 areas but

Table 2. The 20 most diverse regions (TDWG Level 3) for Rubiaceae, based on total species numbers and irrespective of area.

Rank	TDWG Level 3 code	Area (narrative)	No. of species	Area (km ²)
1	CLM	Colombia	1026	1,140,598
2	VEN	Venezuela	785	914,096
3	NWG	New Guinea	725	819,979
4	BZN	Brazil North	645	3,849,262
5	ZAI	Democratic Republic of Congo	644	2,336,991
6	BZL	Brazil Southeast	619	926,896
7	PER	Peru	594	1,296,128
8	ECU	Ecuador	583	249,014
9	BOR	Borneo	578	743,470
10	MDG	Madagascar	569	594,765
11	TAN	Tanzania	559	945,437
12	CMN	Cameroon	553	466,814
13	PHI	Philippines	535	295,856
14	MLY	Malaya	485	132,735
15	CUB	Cuba	438	110,269
16	THA	Thailand	400	514,630
17	PAN	Panama	391	74,845
18	GAB	Gabon	353	261,859
19	CHC	South-Central China	342	1,309,801
20	SUM	Sumatera	342	473,039

does not give us a realistic idea of species richness because of the considerable differences in unit area (square kilometers). In simple terms, TDWG Level 3 areas in the tropics with large unit areas will tend to hold higher numbers of Rubiaceae species than smaller ones, given that other factors (such as forest type and altitude) are comparable. It is expected that areas with a large percentage of low- to mid-altitude humid forest (e.g., Colombia [83 CLM], Venezuela [82 VEN], New Guinea [43 NWG]) will have large numbers of Rubiaceae species per unit areas, for example. Table 3 shows the 20 most diverse areas for Rubiaceae based on relative species richness (species number/area log-transformed [S/1000]; Brummitt & Nic Lughadha, 2003; see Methods), at TDWG Level 3 (Fig. 2). In Table 3, Venezuela (82 VEN) and Colombia (83 CLM) are in comparable positions with those of Table 2 (gross species number), and many other areas remain in Table 3, but the order of areas changes considerably between tables. In Table 3, Brazil North (84 BZN), South-Central China (36 CHC), and Sumatera (42 SUM) are not among the 20 most species-rich areas (cf. Table 2), but instead Costa Rica (80 COS), Gulf of Guinea islands (23 GGI), and New Caledonia (60 NWC) are present. The Gulf of Guinea islands are equatorial continental islands with appreciable amounts of primary lowland forest (Figueiredo, 2005; Davis & Figueiredo, 2007). All major tropical regions (South America, Africa, Indian Ocean, South Asia, Southeast Asia, and the Pacific) are represented in the 20 most species-rich areas,

with no obvious bias to any one of these regions. Of the 20 most species-rich areas, 13 are continental, five are large islands, one is a large island archipelago (Philippines [42 PHI]), and one is a small island group (Gulf of Guinea islands [23 GGI]).

Figure 2 shows the areas within the tropical regions where low relative species richness is anticipated given the paucity of preferred macrohabitat for Rubiaceae (i.e., low- to medium-altitude, humid forest), for example, Rwanda (23 RWA) and perhaps Burundi (23 BUR), where high altitude excludes many species present in surrounding countries, and central and eastern Brazil (84 BZC, BZE), which is largely composed of savanna vegetation (cerrado). Figure 2 also clearly shows several TDWG Level 3 areas where significant relative species richness is expected (proximity to the equator and a prevalence of low-altitude, humid forest) but is not present in our analyses. These areas include Equatorial Guinea (23 EQG), the Democratic Republic of Congo (23 CON), Cambodia (41 CBD), Laos (41 LAO), Sulawesi (42 SUL), and Suriname (82 SUR). For these areas, we assume that low relative species richness is due to low specimen-collecting density per unit area (A. Davis and D. Bridson, pers. obs.) and low levels of taxonomic effort including determination of specimens to species, although these activities are closely associated. We assume that the relatively low collecting densities for the Democratic Republic of Congo (23 CON), Cambodia (41 CBD), and Laos (41 LAO) are due to previous military conflicts and resulting limited

Table 3. Twenty most diverse regions for Rubiaceae based on relative diversity (species number/area log-transformed at TDWG Level 3).

Rank*	TDWG Level 3 code	Area (narrative)	No. of species	Area (km ²)	Mean of z	$c - S/A^z$	$S/10,000$
1 (2)	VEN	Venezuela	785	914,096	0.2331	32.0157	274.0075
2 (1)	CLM	Colombia	1026	1,140,598	0.2862	18.9494	264.4819
3 (15)	CUB	Cuba	438	110,269	0.2116	37.5397	263.5670
4 (10)	MDG	Madagascar	569	594,765	0.2029	38.3264	248.3691
5 (14)	MLY	Malaya	485	132,735	0.2593	22.7694	248.0571
6 (12)	CMN	Cameroon	553	466,814	0.2108	35.2915	245.9629
7 (3)	NWG	New Guinea	725	819,979	0.2486	24.5565	242.4190
8 (11)	TAN	Tanzania	559	945,437	0.1840	44.4524	242.0446
9 (8)	ECU	Ecuador	583	249,014	0.2931	15.2769	227.2141
10 (13)	PHI	Philippines	535	295,856	0.2583	20.6621	223.0354
11 (17)	PAN	Panama	391	74,845	0.3058	12.6374	211.2797
12 (5)	ZAI	Democratic Republic of Congo	644	2,336,991	0.2093	29.9175	205.6487
13 (6)	BZL	Brazil Southeast	619	926,896	0.2513	19.5964	198.3242
14 (9)	BOR	Borneo	578	743,470	0.2526	19.0041	194.6465
15 (25)	COS	Costa Rica	300	51,273	0.3070	10.7445	181.6291
16 (274)	GGI	Gulf of Guinea islands	133	3,208	0.2400	19.1582	174.7251
17 (41)	NWC	New Caledonia	203	19,283	0.2483	17.5181	172.4595
18 (18)	GAB	Gabon	353	261,859	0.2254	21.2101	169.0995
19 (7)	PER	Peru	594	1,296,128	0.2675	13.7611	161.6788
20 (16)	THA	Thailand	400	514,630	0.2324	18.8239	160.0695

A – area, c and z – intercept and slope, respectively, of the regression in a log-log space, S – number of species.

* For rank, numbers in parentheses represent rank based on gross species number per TDWG Level 3 area (Table 2). Areas listed in Table 2 but not appearing in Table 3, with ranking based on relative diversity in parentheses: Brazil North (44), South-Central China (29), and Sumatera (27).

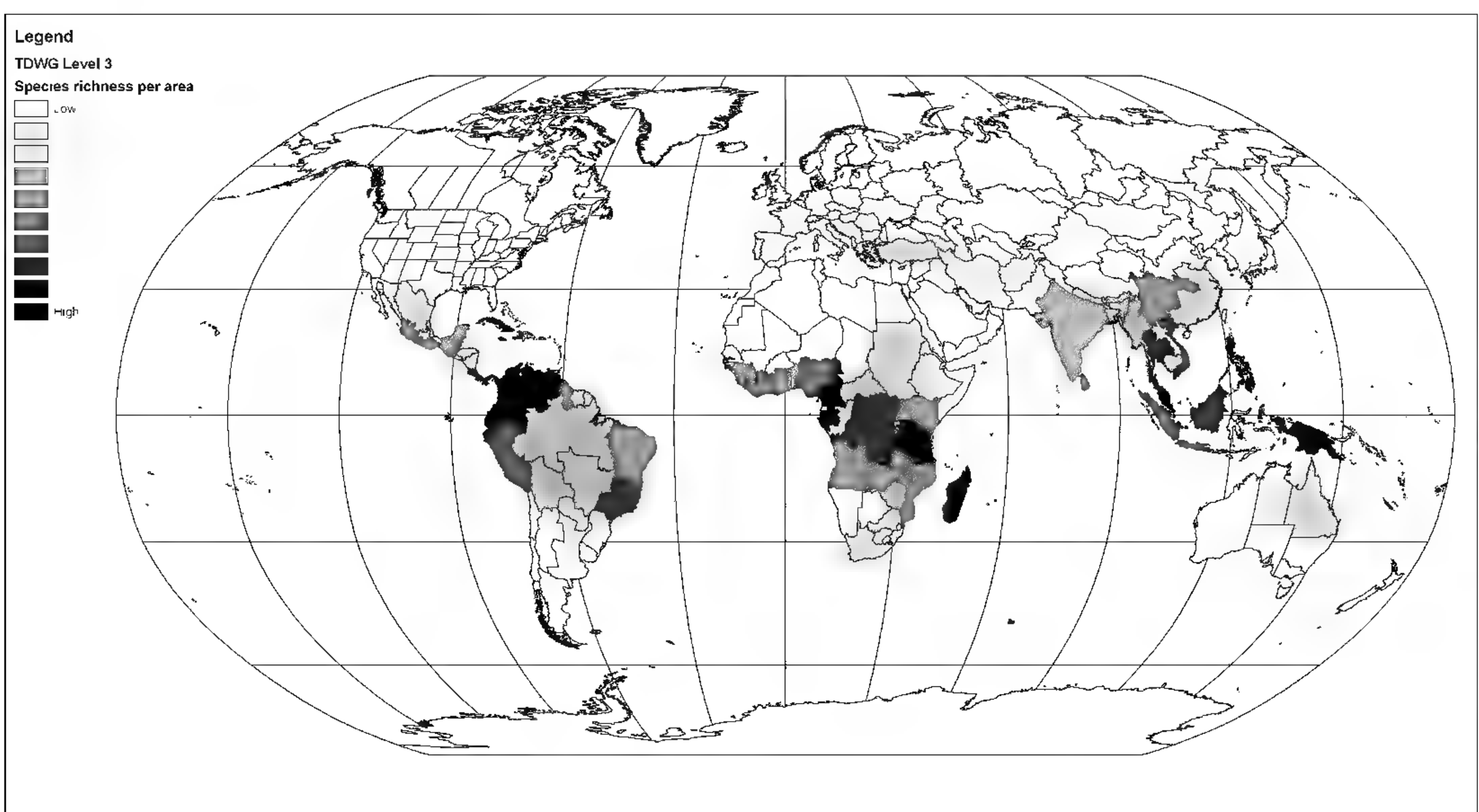

Figure 2. Relative species richness of Rubiaceae at TDWG Level 3 regions rescaled by the size of that region using a power-law species area relationship and standardized to 10,000 km².

Table 4. The 20 highest areas for gross number of endemic Rubiaceae species.

Rank	TDWG Level 3 code	Area (narrative)	No. of species	Endemic species, No. (%)
1	NWG	New Guinea	725	620 (86)
2	MDG	Madagascar	569	520 (91)
3	PHI	Philippines	535	443 (83)
4	BOR	Borneo	578	428 (74)
5	CUB	Cuba	438	344 (76)
6	BZL	Brazil Southeast	619	311 (50)
7	CLM	Colombia	1026	265 (26)
8	VEN	Venezuela	785	252 (32)
9	MLY	Malaya	485	213 (44)
10	NWC	New Caledonia	203	200 (99)
11	TAN	Tanzania	559	190 (34)
12	THA	Thailand	400	179 (45)
13	IND	India	326	169 (52)
14	BZN	Brazil Northeast	702	165 (24)
15	SUM	Sumatera	342	161 (47)
16	CHC	South-Central China	342	149 (44)
17	PER	Peru	594	147 (25)
18	PAN	Panama	391	136 (35)
19	FIJ	Fiji	166	134 (81)
20	VIE	Vietnam	443	129 (29)

access, although priorities set in the colonial era may have also played a role.

ENDEMISM

We provide two crude measures for investigating endemism in Rubiaceae: total number of endemics (Table 4) and percentage of endemism (Table 5) for each TDWG Level 3 area. A few areas of known high endemism cannot be shown by analyses of our data because they are split between different TDWG Level 3 areas. This is particularly marked where mountain ranges coincide with country boundaries (e.g., Rwenzori Mountains, split between the Democratic Republic of Congo [23 ZAI], Rwanda [23 RWA], and Uganda [25 UGA]). For the gross number of endemic species at TDWG Level 3, eight of the 20 highest areas are large islands or island groups, with the first five falling into the island category. The other 12 are continental areas. In terms of percentage of endemism, the first 27 TDWG Level 3 areas are islands, both small and large; Table 5 shows the highest 20 areas for percentage of endemism. High numbers of endemics and percentage of endemics are expected for islands owing to the specific evolutionary scenarios associated with island floras, and, in the case of Rubiaceae, recent and rapid radiations following dispersal (Malcomber, 2002; Maurin et al., 2007) have been particularly important. Continental areas with a high percentage of endemism (44%–50%, e.g., Brazil Southeast [84 BZL], India [40 IND], Thailand [41 THA], South-Central China [36 CHC], Malaya [42

MLY]; Table 4) require further explanation on a case-by-case basis corresponding to their historical and present-day physiography, climate, and biology. Apart from the smaller islands, which have a 100% endemism based on very few species, New Caledonia (60 MWC), Hawaii (63 HAW), and Madagascar (29 MDG) are outstanding in terms of percentage endemism (Table 5). Low percentage endemism is biased toward areas within continental regions, including areas with relatively high number of species but negligible levels of percentage of endemism, such as Liberia (22 LBR), with 210 spp./0% endemism; Ghana (23 GHA), with 248 spp./2% endemism; Malawi (26 MLW), with 213 spp./2% endemism; Uganda (25 UGA), with 212 spp./2% endemism; Central African Republic (23 CAF), with 242 spp./2% endemism; Ivory Coast (22 IVO), with 311 spp./3% endemism; and Nigeria (22 NGA), with 360 spp./4% endemism.

Species endemism is generally high in Rubiaceae. Of the 13,143 species of Rubiaceae, there are 8456 endemics at TDWG Level 3, which means that 64% of Rubiaceae species are endemics at this area level. This level is similar to those of many other large tropical families (e.g., Orchidaceae [Cribb & Govaerts, 2005]) but is much greater than other big families (e.g., Poaceae) that do not have species diversity concentrated in the tropical regions of the world (Govaerts et al., 2006). This may be partly due to the evolutionary history and dynamics of tropical forests but also because dispersal and diversification in Rubiaceae at the species level seem to have

Table 5. The 20 highest areas for gross percentage of endemic Rubiaceae species.

Rank	TDWG Level 3 code	Area (narrative)	Total no. of species	No. of nonendemic species	Endemic species	Endemism, %
1	ASC	Ascension	1	0	1	100
2	STH	St. Helena	1	0	1	100
3	NFK	Norfolk Islands	9	0	9	100
4	KER	Kermadec Islands	2	0	2	100
5	MXI	Mexican Pacific islands	2	0	2	100
6	CPI	Central America Pacific islands	1	0	1	100
7	NWC	New Caledonia	203	3	200	99
8	HAW	Hawaii	47	2	45	96
9	MDG	Madagascar	569	49	520	91
10	NWG	New Guinea	725	105	620	86
11	PHI	Philippines	535	92	443	83
12	FIJ	Fiji	166	32	134	81
13	CUB	Cuba	438	94	344	76
14	MRQ	Marquesas Islands	17	4	13	76
15	BOR	Borneo	578	150	428	74
16	MAU	Mauritius	54	16	38	70
17	SCI	Society Islands	46	14	32	70
18	SOC	Socotra	21	7	14	67
19	ROD	Rodrigues	9	3	6	67
20	JNF	Juan Fernández Islands	6	2	4	67

occurred very recently in many groups (e.g., Malcomber, 2002; Maurin et al., 2007). At the present time, we simply do not have enough data to make supportable assumptions regarding the causes of rapid diversification in Rubiaceae. Considerable levels of endemism occur on both large and small islands and also in continental areas. In studies where area of occurrence and extent of occurrence (IUCN, 2001) have been calculated for Rubiaceae, it appears that many species are highly localized and an alarming number are restricted to area polygons (extent of occurrence) of less than 100 km² (e.g., ca. 14% in *Coffea* [Davis et al., 2006]). Restricted distributions increase the likelihood of extinction, and for groups where extinction threat has been calculated (IUCN, 2001), the number of Threatened taxa is very high, e.g., ca. 70% in *Coffea* (Davis et al., 2006) and 74% in Philippine *Psychotria* (including nearly 10% extinction; Sohmer & Davis, 2007).

CONCLUSION

With 13,183 species in 611 genera, the importance of Rubiaceae in terms of species number is supported by our study, and its position as the fourth largest angiosperm family is confirmed (Robbrecht, 1988) after Orchidaceae, Asteraceae, and Leguminosae. Based on estimates of total species number in

Rubiaceae (i.e., 16,000), we estimate that with current resources it will take us 45 years to fully enumerate species diversity in Rubiaceae. This calculation is oversimplified, as it does not take into account other variables such as names added to or removed from synonymy, and extinction (we have no way of knowing how many species will become extinct before they are discovered), but it does give us some idea of what needs to be done and an indication of where to focus taxonomic resources.

Our assessment of Rubiaceae species diversity for each of the 369 areas of TDWG Level 3 using a measure of relative species diversity (Table 3, Fig. 2) has provided a useful tool for identifying the major areas of relative species diversity for the family. Our analyses confirm that species richness in Rubiaceae is greatest in the tropical regions, particularly in continental areas and larger islands (Table 3, Fig. 2). Practical applications of our species-level diversity analysis include the identification of areas that require further field collections and/or taxonomic study, and the targeting of areas for efficient sample collection (e.g., DNA sampling). Future analyses requiring more precise measures of diversity will need finer division of area and measurement of suitable Rubiaceae habitat, particularly areas of remaining primary vegetation. In addition, reanalysis of Rubiaceae data would be required as our knowledge of the family improves and progresses.

Basic analyses of endemism show that species endemism in Rubiaceae is considerable, with 64% of species endemic at the level of TDWG Level 3, and that percentage endemism is distinctly higher for islands, large and small.

Given the ecologic sensitivity of Rubiaceae (e.g., in the tropical regions mostly requiring primary forest), coupled with the restricted distribution of species, it is evident that many species are vulnerable to extinction, particularly in an era of global environmental change and huge anthropogenic influence at the local level.

Literature Cited

- Andersson, L. 2002. Relationships and generic circumscriptions in the *Psychotria* complex (Rubiaceae, Psychotriaceae). *Syst. & Geogr. Pl.* 72: 167–202.
- Barthlott, W., N. Biedinger, G. Braun, F. Feig, G. Kier & J. Mutke. 1999. Terminological and methodological aspects of the mapping and analysis of global biodiversity. *Acta Bot. Fenn.* 162: 103–110.
- , W. Lauer & A. Placke. 1996. Global distribution of species diversity in vascular plants: Towards a world map of phytodiversity. *Erdkunde* 50: 317–327.
- Bremekamp, C. E. B. 1934. A monograph of the genus *Pavetta* L. *Repert. Spec. Nov. Regni Veg.* 37: 1–208.
- Bremer, K. 1994. *Asteraceae: Cladistics & Classification*. Timber Press, Portland.
- Bridson, D. M. & B. Verdcourt. 2003. Rubiaceae. Pp. 379–720 in G. V. Pope (editor), *Flora Zambesiaca*, Vol. 5, Part 3. Royal Botanic Gardens, Kew.
- Bridson, G. D. R. & E. R. Smith. 1991. B-P-H/S: Botanic-Periodicum Huntianum/Supplementum. Hunt Institute for Botanical Documentation, Carnegie Mellon University, Pittsburgh.
- Brummitt, N. A. 2005. Patterns in the global distribution of flowering plant genera. Pp. 539–564 in I. Friis & H. Balslev (editors), *Plant Diversity and Complexity Patterns: Local, Regional, and Global Dimensions*. Biol. Skr. 55.
- & E. Nic Lughadha. 2003. Biodiversity—Where's hot and where's not. *Conservation Biol.* 17: 1442–1448.
- Brummitt, R. K. 1992. *Vascular Plant Families and Genera*. Royal Botanic Gardens, Kew.
- & C. E. Powell. 1992. *Authors of Plant Names*. Royal Botanic Gardens, Kew.
- (with assistance from F. Pando, S. Hollis, N. A. Brummitt, et al.). 2001. *Plant Taxonomic Database Standards No. 2*, ed. 2. *World Geographical Scheme for Recording Plant Distributions*, ed. 2. Hunt Institute for Botanical Documentation, Carnegie Mellon University, Pittsburgh.
- Burnett, J. 1994. IOPI and the Global Plant Checklist project. *Biol. Int.* 29: 40–44.
- Chevalier, A. 1947. Les caféiers du globe 3: Systématique des caféiers et faux-caféiers; maladies et insectes nuisibles. *Encycl. Biol.* 28: 1–352.
- Clayton, W. D. 1972. Some aspects of the genus concept. *Kew Bull.* 27: 281–287.
- . 1974. The logarithmic distribution of Angiosperm families. *Kew Bull.* 29: 271–279.
- Colwell, R. K. & D. C. Lees. 2000. The mid-domain effect: Geometric constraints on the geography of species richness. *TREE* 15: 70–76.
- Cribb, P. & R. Govaerts. 2005. Just how many orchids are there? Pp. 161–172 in A. Raynal-Roques, A. Roguenant & D. Prat (editors), *Proceedings of the 18th World Orchid Conference*. Orchidées/Naturalia Publications, Turriers, France.
- Cronk, Q. C. B. 1989. Measurement of biological and historical influences in plant classifications. *Taxon* 38: 357–370.
- Davis, A. P. & D. M. Bridson. 2003. Introduction to the Rubiaceae. Pp. 431–434 in S. M. Goodman & J. P. Benstead (editors), *The Natural History of Madagascar*. University of Chicago Press, Chicago.
- & ———. 2007. Rubiaceae. Pp. 284–286 in V. H. Heywood, R. K. Brummitt, A. Culham & O. Seberg (editors), *Flowering Plants of the World*. Royal Botanic Gardens, Kew.
- & E. Figueiredo. 2007. A checklist of the Rubiaceae (coffee family) of Bioko and Annobon (Equatorial Guinea, Gulf of Guinea). *Syst. Biodivers.* 5: 159–186.
- , D. M. Bridson, C. Jarvis & R. Govaerts. 2001. The typification and characterization of the genus *Psychotria* L. (Rubiaceae). *Bot. J. Linn. Soc.* 135: 35–42.
- , R. Govaerts, D. M. Bridson & P. Stoffelen. 2006. An annotated taxonomic conspectus of the genus *Coffea* (Rubiaceae). *Bot. J. Linn. Soc.* 152: 465–512.
- , ——— & M. Briggs. 2007. Indian Ocean *Mapouria* species transferred to *Psychotria* (Rubiaceae–Psychotriaceae). *Blumea* 52: 245–262.
- De Block, P., S. Dessein & E. Robbrecht. 2006. Third International Rubiaceae Conference. Programme & Abstracts. *Scripta Bot. Belg.* 40: 1–92.
- Figueiredo, E. 2005. The Rubiaceae of São Tomé e Príncipe (Gulf of Guinea): Taxonomy and conservation. *Bot. J. Linn. Soc.* 149: 85–114.
- Frodin, D. 2004. History and concepts of big plant genera. *Taxon* 53: 741–752.
- Funk, V. A., R. J. Bayer, S. Keeley, R. Chan, L. Watson, B. Gemeinholzer, E. Schilling, J. L. Panero, B. G. Baldwin, N. Garcia-Jacas, A. Susanna & R. K. Jansen. 2005. Everywhere but Antarctica: Using a supertree to understand the diversity and distribution of the Compositae. *Biol. Skr.* 55: 343–374.
- Gaston, K. J. 2003. *The Structure and Dynamics of Geographic Ranges*. Oxford University Press, Oxford.
- Govaerts, R. 2006. World Checklist of Monocotyledons. The Board of Trustees of the Royal Botanic Gardens, Kew. <<http://www.kew.org/wcsp/monocots>>, accessed 6 December 2006.
- , D. G. Frodin & A. Radcliffe-Smith. 2000. World Checklist and Bibliography of Euphorbiaceae (and Pandaceae). Royal Botanic Gardens, Kew.
- , M. Ruhsam, L. Andersson, E. Robbrecht, D. M. Bridson, A. P. Davis, I. Schanzer & B. Sonké. 2006. World Checklist of Rubiaceae. The Board of Trustees of the Royal Botanic Gardens, Kew. <<http://www.kew.org/wcsp/rubiaceae>>, accessed 15 December 2006.
- Holmgren, P. K., N. H. Holmgren & L. C. Barnett. 1990. *Index Herbariorum*. New York Botanical Garden, Bronx.
- IUCN. 2001. IUCN Red List Categories and Criteria Version 3.1. Prepared by the IUCN Species Survival Commission. IUCN, Gland, Switzerland, and Cambridge, United Kingdom.
- Kier, G., J. Mutke, E. Dinerstein, T. H. Ricketts, W. Küper, H. Kreft & W. Barthlott. 2005. Global patterns of plant diversity and floristic knowledge. *J. Biogeogr.* 32: 1107–1116.

- Knapp, S., E. Nic Lughadha & A. J. Paton. 2005. Taxonomic inflation, species concepts and global species lists. *TREE* 20: 7–8.
- Lantz, H. & B. Bremer. 2004. Phylogeny inferred from morphology and DNA data: Characterizing well-supported groups in Vanguerieae (Rubiaceae). *Bot. J. Linn. Soc.* 146: 257–283.
- Lewis, G., B. Schrire, B. Mackinder & M. Lock. 2005. *Legumes of the World*. Royal Botanic Gardens, Kew.
- Mabberley, D. J. 1987. *The Plant-Book: A Portable Dictionary of the Higher Plants*. Cambridge University Press, Cambridge.
- . 1997. *The Plant-Book: A Portable Dictionary of the Higher Plants*, 2nd ed. Cambridge University Press, Cambridge.
- Malcomber, S. T. 2002. Phylogeny of *Gaertnera* Lam. (Rubiaceae) based on multiple DNA markers: Evidence of rapid radiation in a widespread morphologically diverse genus. *Evolution* 56: 42–57.
- Maurin, O., A. P. Davis, M. Chester, E. F. Mvungi, Y. Jauferally-Fakim & M. F. Fay. 2007. Phylogenetic relationships in *Coffea* (Rubiaceae) inferred from sequence data and morphology. *Ann. Bot.* 100: 1565–1583.
- Mutke, J. & W. Barthlott. 2005. Patterns of vascular plant diversity at continental to global scales. *Biol. Skr.* 55: 521–538.
- Nepokroeff, M., B. Bremer & K. J. Sytsma. 1999. Reorganization of the genus *Psychotria* and tribe Psychotrieae (Rubiaceae) inferred from ITS and *rbcL* sequence data. *Syst. Bot.* 24: 5–27.
- Nic Lughadha, E. 2004. Towards a working list of all known plant species. *Philos. Trans., Ser. B* 359: 681–687.
- , J. Baillie, W. Barthlott, N. A. Brummitt, M. R. Cheek, A. Farjon, R. Govaerts, K. A. Hardwick, C. Hilton-Taylor, T. R. Meagher, J. Moat, J. Mutke, A. J. Paton, L. J. Pleasants, V. Savolainen, G. E. Schatz, P. Smith, I. Turner, P. Wyse-Jackson & P. R. Crane. 2005. Measuring the fate of plant diversity: Towards a foundation for future monitoring and opportunities for urgent action. *Philos. Trans., Ser. B* 360: 359–372.
- Olson, D. M., E. Dinerstein, E. D. Wikramanayake, N. D. Burgess, G. V. N. Powell, E. C. Underwood, J. A. D'Amico, I. Itoua, H. Strand, J. C. Morrison, C. J. Loucks, T. F. Allnut, T. H. Ricketts, Y. Kura, J. F. Lamoreux, W. W. Wettengel, P. Hedao & K. R. Kassem. 2001. Terrestrial ecoregions of the world: A new map of life on earth. *Bioscience* 51: 933–938.
- Robbrecht, E. 1988. Tropical woody Rubiaceae. *Opera Bot. Belg.* 1: 1–271.
- Rosenzweig, M. L. 1995. *Species Diversity in Space and Time*. Cambridge University Press, Cambridge.
- Ruhsam, M., R. Govaerts & A. P. Davis. 2008. Nomenclatural changes in preparation for a *World Rubiaceae Checklist*. *Bot. J. Linn. Soc.* 157: 115–124.
- Secretariat of the Convention on Biological Diversity. 2002. *Global Strategy for Plant Conservation*. Secretariat of the Convention on Biological Diversity, Montreal.
- Smith, A. C. 1988. *Flora Vitiensis Nova*, Vol. 4. Pacific Tropical Botanical Garden, Honolulu.
- Sohmer, S. H. 1988. The nonclimbing species of the genus *Psychotria* (Rubiaceae) in New Guinea and the Bismarck Archipelago. *Bishop Mus. Bull. Bot.* 1: 1–339.
- & A. P. Davis. 2007. The genus *Psychotria* (Rubiaceae) in the Philippine Archipelago. *Sida, Bot. Misc.* 27: 1–267.
- Stafleu, F. A. & R. S. Cowan. 1976–1988. *Taxonomic Literature: A Selective Guide to Botanical Publications and Collections with Dates, Commentaries, and Types*. 7 Vols., ed. 2. *Regnum Veg.*, Vols. 94, 98, 105, 110, 112, 115–116. Scheltema and Holkema, Bohn, Utrecht.
- & E. A. Mennega. 1992–2000. *Taxonomic Literature: A Selective Guide to Botanical Publications and Collections with Dates, Commentaries, and Types*. Supplement. 6+ vols. *Regnum Veg.*, Vols. 125, 130, 132, 134–135, 137. Koeltz Scientific Books, Königstein.
- Taylor, C. M. 1996. Overview of the Psychotrieae (Rubiaceae) in the Neotropics. *Opera Bot. Belg.* 7: 261–270.
- . 2001. Overview of the Neotropical Genus *Noto-pleura* (Rubiaceae: Psychotrieae), with the description of some new species. *Ann. Missouri Bot. Gard.* 88: 478–515.
- Vega, F. E., E. Rosenquist & W. Collins. 2003. Global project needed to tackle coffee crisis. *Nature* 425: 343.
- Verdcourt, B. 1976. *Flora of Tropical East Africa. Rubiaceae (Part 1)*. Pp. 1–414 in R. H. Polhill (editor), *Flora of Tropical East Africa. Rubiaceae, Part 1*. Whitefriars Press Ltd., London.
- . 1989. *Rubiaceae*. Pp. 1–210 in E. Launert (editor), *Flora Zambesiaca, Vol. 5, Part 1*. Royal Botanic Gardens, Kew.
- Wernham, H. F. 1914. *A monograph of the genus Sabicea*. Trustees of the British Museum, London.
- . 1918–19. *The genus Manettia*. *J. Bot.* 57(suppl.): 1–44.
- Winkler, H. 1922. *Monographische Übersicht der Gattung Leptodermis*. *Repert. Spec. Nov. Regni Veg.* 18: 146–166.

TAXONOMIC HISTORY, MORPHOLOGY, AND REPRODUCTIVE BIOLOGY OF THE TRIBE POSOQUERIEAE (RUBIACEAE, IXOROIDEAE)¹

Piero G. Delprete²

ABSTRACT

The tribe Posoquerieae was recently described to include the genera *Posoqueria* Aubl. and *Molopanthera* Turcz. based on floral morphology, palynology, the presence of the pollen catapult mechanism, and molecular phylogenetic evidence. The floral morphology of these two genera was first recognized as unique in the Rubiaceae by Schumann. Both genera have stamens initially united into an ellipsoidal structure held at an oblique position, with the ventral stamen that springs forward when touched, while the two lateral stamens fold outward. Since their descriptions were published, *Posoqueria* and *Molopanthera* have been positioned in several distantly related tribes within the Rubiaceae. The close relationship between the two genera was only recently revealed by molecular phylogenetic studies. The taxonomic history of *Posoqueria* and *Molopanthera* is reviewed, and a general morphological comparison (particularly of stamen morphology and pollen catapult mechanism, and observations about pollination biology) of both genera is presented here. The pollen catapult mechanism of *Molopanthera* is described here in detail for the first time and concluded to be practically identical to that of *Posoqueria*.

Key words: Gardenieae, *Molopanthera*, Neotropics, pollen catapult mechanism, *Posoqueria*, Posoquerieae, Rubiaceae.

The genus *Posoqueria* Aubl. was established by Aublet (1775) based on his material from French Guiana and on *P. longiflora* Aubl. He explained that the generic name was derived from the name used by the Galibi tribe, “Aymara-Posoqueri,” because the fish Aymara eats the fruits of this plant. However, the typical laterally bent floral buds of this genus were not depicted in the drawing.

De Candolle (1830) included *Posoqueria* in the tribe Gardenieae (as “Gardeniaceae”) and, more specifically, in the subtribe Gardeniinae (as “Gardenieae”; de Candolle, 1830: 368), among genera now positioned in several other tribes. In *Posoqueria*, de Candolle recognized seven species, namely *P. longiflora*, *P. latifolia* Roem. & Schult., *P. decora* DC., *P. trinitatis* DC., *P. havanensis* DC., *P. gracilis* Roem. & Schult., and *P. revoluta* Nees [*P. revoluta* Schrad.].

Turczaninow (1848) published *Molopanthera* Turcz., describing *M. paniculata* Turcz., and treated

it as a genus with uncertain tribal position, differing from all the Rubiaceae genera with a multi-ovulate ovary. He derived the generic name from the Greek μώλωψ- (molops- – bruise or weal) and -ανθηρα (anthera – anther) meaning bruised anthers, probably in allusion to the dark ends of the anthers, which are the points of fusion of the anthers in two pairs (the other anther remaining solitary).

Karsten (1849) described the genus *Stannia* H. Karst., based on *S. formosa* H. Karst., which he distinguished from *Posoqueria* based mostly on stamen length (all equal in *Posoqueria*; three out of five longer and curved in *Stannia*). Müller (1866), probably unaware of Karsten’s *Stannia*, also described the genus as *Martha* F. J. Müll., which he distinguished from *Posoqueria* because of the unequal stamens. In this work, he was the first to describe, in great detail, the catapult mechanism for throwing the pollen onto the flower visitors, observed on plants

¹This research was realized during a Visiting Scientist fellowship from the Conselho Nacional de Desenvolvimento Científico e Tecnológico (CNPq) at the Institute of Biological Sciences of the Universidade Federal de Goiás (UFG), Goiânia, Goiás, Brazil. Observations of flowering individuals of *Molopanthera* were made at the Feliciano Miguel Abdala Natural Heritage Private Reserve (commonly known as the “Caratinga Biological Station”), Minas Gerais, Brazil. Special thanks are due to the administration and guides of the reserve for help in locating a healthy population of this rare species. Additional observations were made at the herbarium of the Universidade Federal de Minas Gerais, Belo Horizonte, and the curator Alexandre Salino, and Marcos Sobral, are kindly acknowledged. A travel grant for the presentation of this work at the Third International Rubiaceae Congress was provided by the Fund for Scientific Research–Flanders (FWO N. WO.005.05) and the Laboratory of Plant Systematics of the Katholieke Universiteit, Leuven, Belgium.

²CNPq Visiting Scientist, Institute of Biological Sciences (ICB-1), Department of General Biology/Botany, Universidade Federal de Goiás, Campus II, 74001-970 Goiânia, Goiás, Brazil. Current address: Institut de Recherche pour le Développement, Botanique et Bioinformatique de l’Architecture des Plantes (AMAP), TA-A51/PS2, Blvd. de la Lironde, 34398 Montpellier Cedex 5, France. pdelprete@hotmail.com.

doi: 10.3417/2006192

growing in his private garden at Desterro, Santa Catarina, southern Brazil. The peculiar mechanism was later commented on by Charles Darwin (1876, 1877), based on the notes and material sent to him by Müller.

Hooker (1873: 8–9) positioned *Posoqueria* in the Gardenieae, which he distinguished from the Catesbaeeae by having (translated from Latin) “corolla narrowly contorted, seeds few to many, large, compressed, or small, angled” (vs. “corolla valvate, seeds many, large to very large, compressed” in the Catesbaeeae). He divided the Gardenieae into several informal groups based on flower sexuality, inflorescence position, style morphology, number of locules, and ovules biseriate or multiseriate. Hooker positioned *Posoqueria* in the group with terminal inflorescence and hermaphroditic flowers, rarely polygamo-dioecious. He further distinguished *Posoqueria* from the other genera of this group with its corymbose inflorescence, flowers with elongated corolla tube, corolla lobes gibbous in bud, five exerted anthers, and a bifid stigma. Under this genus, he synonymized *Solena* Willd., *Cyrtanthus* Schreb., *Kyrtanthus* J. F. Gmel., and *Stannia*. However, Hooker did not include *Martha* in the list of synonyms, probably unaware of its publication. In *Posoqueria*, he recognized 12 species distributed in tropical America. Although he described the flower buds as laterally gibbous and the filaments as erect or curved, he did not mention the peculiar pollen catapult mechanism. At the same time, Hooker placed *Molopanthera* in the Cinchoneae in the group with imbricate corolla lobes (one or two exterior) and stamens inserted at the base of the corolla. In addition, he described a second species, *M. burchellii* Hook. f., which he distinguished from the typical species by having pubescent vegetative parts.

Baillon (1880) included the Gardenieae into his broadly circumscribed Genipa Series or Genipeae, where he positioned *Posoqueria* (Baillon: 435; including *Solena*, *Cyrtanthus*, *Kyrtanthus*, *Posoria* Raf., and *Stannia*). He stated that *Posoqueria* “closely approaches the Genipas with elongated corolla” and treated it as closely related to *Oxyanthus* DC. and *Kutchubaea* Fisch. ex DC. In the same work, he maintained *Molopanthera* in the Cinchoneae, following the position and definition suggested by Hooker (1873), and positioned it near *Calycophyllum* DC. because of the 4- to 5-merous flowers, 2-locular capsules, and seeds with unequally dentate wing.

The generic delimitations of *Posoqueria* and *Stannia* were repeatedly debated among Karsten (1849, 1856, 1860, 1887) and Planchon (1850), and Hooker (1873) and Baillon (1880), resulting in a complex diatribe of heated arguments published in a series of publications. Karsten put forward that *Stannia* has unequal stamens (with three stamens

curved and longer) and leathery or lignified berries, while *Posoqueria* has equal stamens and juicy or fleshy berries. The other authors considered these characters trivial and preferred to synonymize the two genera. Because the flower buds have the portion with the corolla lobes curved on one side, the stamens located on the inner portion of the curvature are shorter. This debate was summarized by Schumann (1888: 351–360; see annotated translation by Delprete et al., 2005a: 50–58). Schumann agreed with most authors in synonymizing the two genera and stressed that in both taxa the stamens are unequal. In addition, he used the morphology of the anthers as the unifying character and stated that (translated from German; Delprete et al., 2005a: 55): “The anthers have a wide, dorsal area that is slightly curved from top to bottom and also from right to left. They are of rather firm consistency, and are truly introrse, whereby the two parallel, closely touching thecae are flattened with inclined, slightly angled sides like normal ones. These are not tapered at the top nor at the base, but the anthers are rather bounded by firm, solid ends on both sides. There are stiff, short bristles located at the sides of the anthers, in addition to very shallow papillae, which are only visible with a lens, and which give the surface an iridescent appearance” (Schumann, 1888: 356).

Most importantly, Schumann (1888, 1891) was the first to notice the overall similarity of the pollen catapult mechanism of *Posoqueria* and *Molopanthera* and its uniqueness within the family. He observed the flower buds of *Molopanthera* in herbarium specimens, noticed that the anthers are initially united in an ellipsoidal structure while in flower bud, and suspected the stamen catapult mechanism. He wrote, “I think it is not impossible that this movement is executed with certain vehemence. But this question can only be investigated with living material, which is something I should like to point out to those botanists, who are lucky enough to be in a position to do this” (Schumann, 1888: 357, translated from German; Delprete et al., 2005a: 56). Schumann also compared the floral morphology and pollen catapult mechanism with that of *Posoqueria* and declared that they correspond entirely. Furthermore, he compared the corolla aestivation of the two genera and described them with lobes variably overlapping, stating that in *Molopanthera* “the two lowermost lobes overlap the two middle ones, and these two [in turn] cover the one on top. This aestivation is constant, and without a doubt the result of corolla genesis. Inconsistent is only the overlapping of the two front corolla lobes, and this I have also always found in ascending aestivation. Here the right lobe sometimes overlaps the one to the left and vice versa. Bearing these observations in

mind, I examined, with some difficulty, the aestivation of *Posoqueria*, and I was finally able to definitely ascertain that it was exactly the same as in *Molopanthera*" (Schumann, 1888: 359, translated from German; Delprete et al., 2005a: 58).

Schumann (1891: 9–10) positioned both genera in the subfamily Cinchonoideae. However, probably because of the capsular fruits, he included *Molopanthera* in the tribe Cinchoneae, subtribe Cinchoniinae (as "Cinchoninae–Cinchoneae"), near *Coutarea* Aubl., the only other genus of this group with zygomorphic flowers. On the other hand, he positioned *Posoqueria* in the tribe Gardenieae, subtribe Gardeniinae (as Eugardenieae), probably because of its leathery berries, and distinguished it from the other genera by having flower buds laterally bent at the lobes portion.

Bremekamp (1934a) criticized the classification proposed by Schumann (1888, 1891) and contributed several important improvements. In addition, he proposed the ixoroid pollination syndrome (pollen presentation at the style apex) as a strong taxonomic character for the subfamily Ixoroideae. However, his classification was focused on genera occurring in Suriname, thus he did not discuss the systematic position of *Molopanthera*. He placed the Gardenieae within the Ixoroideae and, in the three works dedicated to the *Flora of Surinam* (Bremekamp, 1934a, b, 1937), maintained *Posoqueria* in the Gardenieae. However, following Schumann's observations (1888, 1889, 1891), he stated that *Posoqueria* does not belong to this tribe, but did not suggest any other position in the family. In fact, the pollen catapult mechanism of *Posoqueria* (and *Molopanthera*) is not a form of secondary presentation, as the pollen is thrown directly from the anther onto the pollinator.

Verdcourt's (1958) family classification was profoundly influenced by the taxonomic observations of Bremekamp, and he agreed with that author that *Posoqueria* "will have to be excluded [from the Gardenieae], but do not know where it should be put. It has a higher chromosome number than has been reported for any other Rubiaceae, peculiar horny anthers like some Apocynaceae and it does not show the ixoroid pollen mechanism that other members of the tribe possess" (Verdcourt, 1958: 246).

Bremekamp (1966: 25–26), in his last notes on Rubiaceae classification, declared that "[t]he true Gardenieae are recognizable by their many seeded, comparatively large fruits, which are provided with a thick, leathery or more or less woody pericarp and gelatinous endocarp in which the numerous seeds are embedded. They are not rarely dioecious, in which case the male flowers are provided with a style of which the upper part serves as 'receptaculum pollinis.'

Fruits of the kind described above are found in the genera *Gardenia* Ellis, *Randia* Houst. [*Randia* L.], *Rosenbergiodendron* Fagerl., *Tocoyena* Aubl., *Genipa* L., *Alibertia* A. Rich., *Ibetralia* Bremek. [– *Kutchuba*], *Duroia* L. f. and perhaps some other ones." In addition, he maintained that *Posoqueria* is excluded from the Gardenieae as a genus probably related to *Cladoceras* Bremek. because of the unique pollination mechanism.

Robbrecht and Puff (1986) presented a comprehensive survey of the Gardenieae–Ixoreae complex using data from morphology, anatomy, cytology, and reproductive biology. However, several Neotropical genera traditionally positioned in the Gardenieae were not mentioned in the study, among them *Melanopsidium* Colla, *Posoqueria*, and *Botryarrhena* Ducke.

Robbrecht (1988) proposed a system of classification highly influenced by that of Bremekamp (1966), complemented by a synthesis of all the data available to him at that time. He divided the family into four subfamilies and 44 tribes and positioned the Gardenieae in the subfamily Ixoroideae. He delimited the Gardenieae according to the conclusions presented by Robbrecht and Puff (1986) and divided it into the Diplosporinae and Gardeniinae, positioning *Posoqueria* in the second subtribe without any additional comments.

Andersson and Persson (1991) presented a phylogenetic study with an attempt to define the tribe Cinchoneae. In this work, *Molopanthera* was found in a basal position near *Condaminea* DC. in the two analyses using a hypothetical taxon (combining the characters of the Loganiaceae genera *Antonia* Pohl and *Gelsemium* Juss.) as outgroup, and as sister genus with *Condaminea* in the analyses using *Gelsemium* as outgroup. These results prompted the authors to include *Molopanthera* among the genera that they provisionally transferred to the Condamineae.

Delprete (1993) presented a preliminary phylogeny using morphological characters focused on representative genera of the Chiococceae, Catesbaeeae, Condamineae, and Rondeletieae. Based on the results of this study, he indicated that the subtribe Portlandiinae of the Condamineae should be separated as the informal Portlandia group in which the genera *Catesbaea* L. and *Phyllacanthus* Hook. f. (Catesbaeeae) should be included. In addition, he indicated that *Molopanthera* might be tentatively included within the Rondeletieae.

Robbrecht (1993), in a supplement to his 1988 classification and following Delprete's preliminary results, separated the "genera associated with *Portlandia*." He positioned this informal group near the Condamineae, with the note "If the Catesbaeeae are

included (see tribus incertae), they will provide a tribal name for this group" (Robbrecht, 1993: 176). Within this informal group, he included *Molopanthera* without any further comments.

Delprete (1996) published an expanded phylogenetic study based on morphological characters presented in 1993. In the analysis using *Cinchona* L. and *Joosia* H. Karst. as outgroup, *Molopanthera* appeared at a basal unresolved position. In the analyses using solely *Coffea* L. as outgroup and in that with *Coffea*, *Cinchona*, and *Joosia* as outgroup, *Molopanthera* was positioned in a clade with *Parachimarrhis* Ducke and *Simira* Aubl. These results prompted Delprete to propose *Molopanthera* as a member of the Condamineeae–Rondeletieae complex (Rondeletieae s.l.).

Persson (1996) published a phylogenetic study of the tribe Gardenieae using morphological characters. In the cladograms obtained, *Posoqueria* was positioned within the outgroup, with the following parallelisms: apical extension of connective absent, placental pulp present, and exotesta without radial and tangential wall thickenings. Based on these results, Persson excluded *Posoqueria* from the Gardenieae, but did not further indicate its position in the family.

Delprete (1999) included *Molopanthera* in his widely delimited Rondeletieae (including Sipaneeae and Condamineeae p.p.) as related to *Chimarrhis* Jacq. because of its narrowly imbricate corollas and placentation. In his taxonomic revision, he maintained it as a monospecific genus, with the same two varieties recognized by Schumann (1889).

Rova et al. (2002), with a molecular phylogeny using *trnL-F* sequences, were the first to demonstrate the close phylogenetic relationship between the *Posoqueria* and *Molopanthera*. In turn, they were found to be closely associated with the tribes Henriquezieae and Sipaneeae, as further supported by the molecular phylogenies of Delprete and Cortés-B. (2004) and Cortés-B. et al. (2005), using *trnL-F* and *rps16* sequences.

Delprete (2004), based on morphological, palynological, and phylogenetic evidence, described the new tribe Posoquerieae, with these genera as shrubs or small to tall trees, with stipules triangular or oblong-lanceolate; terminal inflorescences; flower buds gibbous (*Posoqueria*) or curved (*Molopanthera*); corolla zygomorphic, long-tubular (*Posoqueria*) or rotate, small (*Molopanthera*); anthers apiculate, base agitate or caudate, organized in bud in two pairs with a single one bearing a pollen mass released by all the anthers; pollen grains 3-colporate; ovary bilocular; fruits baccate (*Posoqueria*) or capsular (*Molopanthera*); and seeds many, large, and wingless with testa coriaceous,

perlaceous (*Posoqueria*) or seeds minute with wing lacerate-dentate and testa membranaceous (*Molopanthera*).

Robbrecht and Manen (2006) proposed a new family classification based on a phylogeny obtained from nuclear and chloroplast DNA sequences (supertree technique). In this new system, they divided the Rubiaceae into two subfamilies and several supertribes. They reduced the tribes Henriquezieae and Posoquerieae to subtribes of the expanded Henriquezieae (sister to the tribe Sipaneeae). However, despite these recent results, I prefer to maintain the Henriquezieae and Posoquerieae as sister tribes. The remarkable floral morphological characters and the pollen catapult system unique to the Posoquerieae warrant recognition at the tribal level. Furthermore, the Henriquezieae show some very different characters, e.g., the half-superior to superior ovaries.

CHARACTERIZATION OF THE TRIBE POSOQUERIEAE

Genera with zygomorphic flowers are uncommon in the Rubiaceae; however, the trademark of the tribe Posoquerieae is the peculiar pollen catapult mechanism that requires a composition of morphological and functional characters in order to undergo the various stages of anthesis (see below). With the goal of having a general view of the morphological variation in the tribe and a comparison between the two genera included, an itemized characterization is presented below.

GEOGRAPHIC DISTRIBUTION

Posoqueria is a genus of about 17 species distributed throughout the Neotropics, from Central America to southern Brazil (Macias, 1988; Taylor & Cortés-B., 1999; Boom & Delprete, 2002; Macias & Kinoshita, 2003; Delprete et al., 2005b). *Molopanthera* is a monospecific genus (Delprete, 1999) endemic to the Atlantic forests of Brazil, with two varieties distinguished by the type of vestiture of the vegetative parts.

HABIT

Posoqueria species are large shrubs (1.5–)2–7 m tall or, exceptionally, trees to 15(–20) m tall (especially the Amazonian species), with bark usually smooth, or rarely shallowly fissured in old trees. *Molopanthera* is represented by trees 5–10(–30) m tall, with the main trunk 15–30(–80) cm DBH, and the bark longitudinally fissured (Fig. 1B) and pale brown.

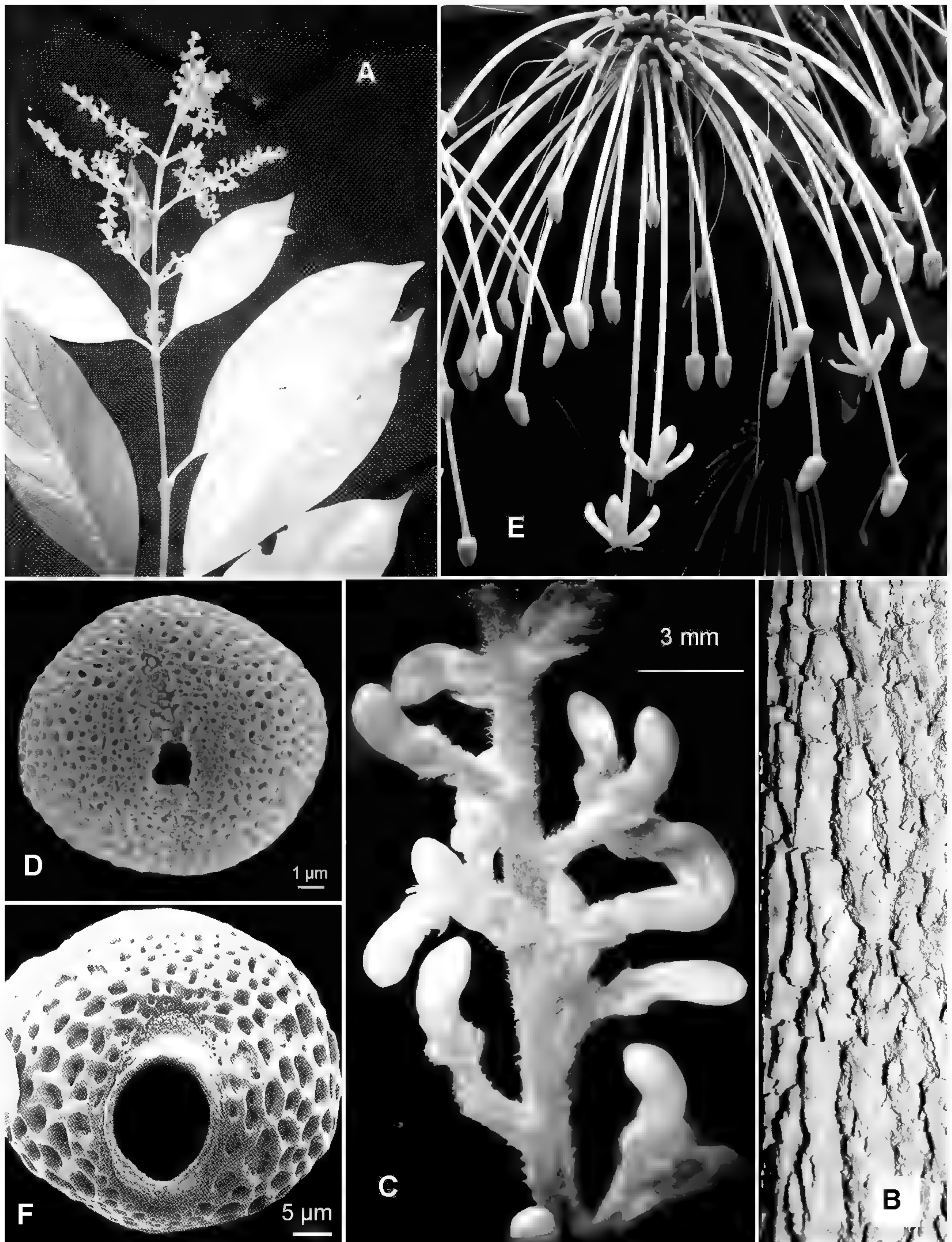

Figure 1. *Molopanthera* and *Posoqueria*. A–D. *Molopanthera paniculata*. —A. Inflorescence. —B. Bark. —C. Detail of inflorescence with flower buds. —D. Pollen. E, F. *Posoqueria longiflora*. —E. Inflorescence with flower buds and open flowers. —F. Pollen. (A–C photos by P. Delprete; D reproduced with permission from Huysmans et al., 1999; E photo by L. Westra; F reproduced with permission from Persson, 1993.)

LEAVES

The leaves of both genera are ovate, elliptic, or oblong-elliptic and have brochidodromous venation (Fig. 1A), which is the common condition in the family.

STIPULES

As in most members of the family, the stipules of both genera are interpetiolar and free at the base, although they differ in several characters. In *Posoqueria*, they are ovate, narrowly triangular, oblong, ligulate, or lanceolate and are readily caducous, while those of *Molopanthera* are broadly triangular at the base, acuminate at the apex, and persistent.

INFLORESCENCE

In both genera, the inflorescences are terminal. In *Posoqueria*, they are cymose or corymbose, and few- to many-flowered. On the other hand, those of *Molopanthera* are laxly paniculate, many-flowered, with secondary branches subtended by leaf-like bracts (pherophylls), tertiary branches thyrsoid, and with 1- to 3-flowered terminal units (Fig. 1A, C).

FLOWERS

In both genera, the flowers are zygomorphic, 5-merous, bisexual, and protandrous, with a glabrous corolla that is white to cream-white during anthesis, commonly turning pale yellow to yellow after anthesis. However, the main contrast between the two taxa is the difference in corolla size and shape. In *Posoqueria*, the flower buds are narrowly cylindrical and laterally bent at the apex (corolla lobes); the corollas are hypocrateriform, 7–35(–38) cm long (28–35[–38] cm long in *P. longiflora*; Fig. 1E), with a long, narrowly cylindrical tube, 5–32(–34) cm long; and the corolla lobes are equal or unequal, imbricate or left-contorted, ovate, oblong-ovate, or oblong to lanceolate, and obtuse or round at apex. In *Posoqueria*, the flowers are odorless or slightly fragrant during the daytime, becoming strongly fragrant from dusk to the middle of the night. They are visited and probably pollinated by long-tongued sphingid moths (Bawa & Beach, 1983; and pers. obs.).

In *Molopanthera*, the flower buds are curved, slightly wider medio-distally (at the anther position); the corollas are rotate, deeply lobed, 3–4 mm long, with a short, cylindrical tube, 0.3–0.5 mm long (Fig. 1C); and the corolla lobes are unequal in length (shorter on the ventral side of the bud), imbricate, oblong-linear, and round at apex. In *Molopanthera*, the flowers are sweet-scented and open during the

daytime. They are visited and probably pollinated by small bees (pers. obs.).

STAMENS

In most species of *Posoqueria*, the two dorsal filaments are the longest, the two lateral ones are of intermediate length, and the ventral one is the shortest. However, in a few species (e.g., *P. taraiensis* C. M. Taylor & Cortés-Ballén), the filaments are of equal length and during anthesis they separate independently. This species does not show the typical pollen catapult mechanism. Only a few species of *Posoqueria* have been closely examined for the unequal length of the filaments, and even fewer were directly observed during anthesis.

In *Molopanthera*, stamen morphology and pollen release are very similar to those of *Posoqueria*. As in *Posoqueria*, the anthers are initially united in an ellipsoidal structure held slightly oblique (Fig. 2A) according to the flower bud curvature; the two dorsal stamens are the longest, the two lateral ones are of intermediate length, and the solitary one (inserted at the ventral portion) is the shortest. The anthers are all of equal length, although those connected in pairs are slightly narrower than the solitary one (responsible for throwing the pollen onto the pollinator).

POLLEN PRESENTATION

Most species of *Posoqueria* display the characteristic pollen catapult mechanism, which is the trademark feature of the Posoquerieae. However, the presence of this peculiar mechanism has not been observed in all the species of the genus, as some species apparently have equal or subequal stamens that separate freely, without performing the pollen catapult (as reported by Burk [1884] in "*Posoqueria hirsuta*," a name of doubtful application). In other species, the separation of the stamens occurs only after the pollen dispersal. Therefore, even though most species have been reported to display the typical pollen catapult mechanism, this remains to be confirmed in a number of species.

The pollen catapult mechanism of *Posoqueria latifolia* was first described, in much detail, by Müller (1866) and later by Hallé (1967), Beach (1983), and Puff et al. (1995). In addition, I have personally observed *P. latifolia* in several natural populations in Costa Rica and central and southern Brazil (states of Goiás, Minas Gerais, and Santa Catarina), and this species is used here as an example for the several stages in the anthesis. In *P. latifolia*, the five anthers are initially united into an ellipsoidal structure, which is held in an oblique position in relation to the corolla

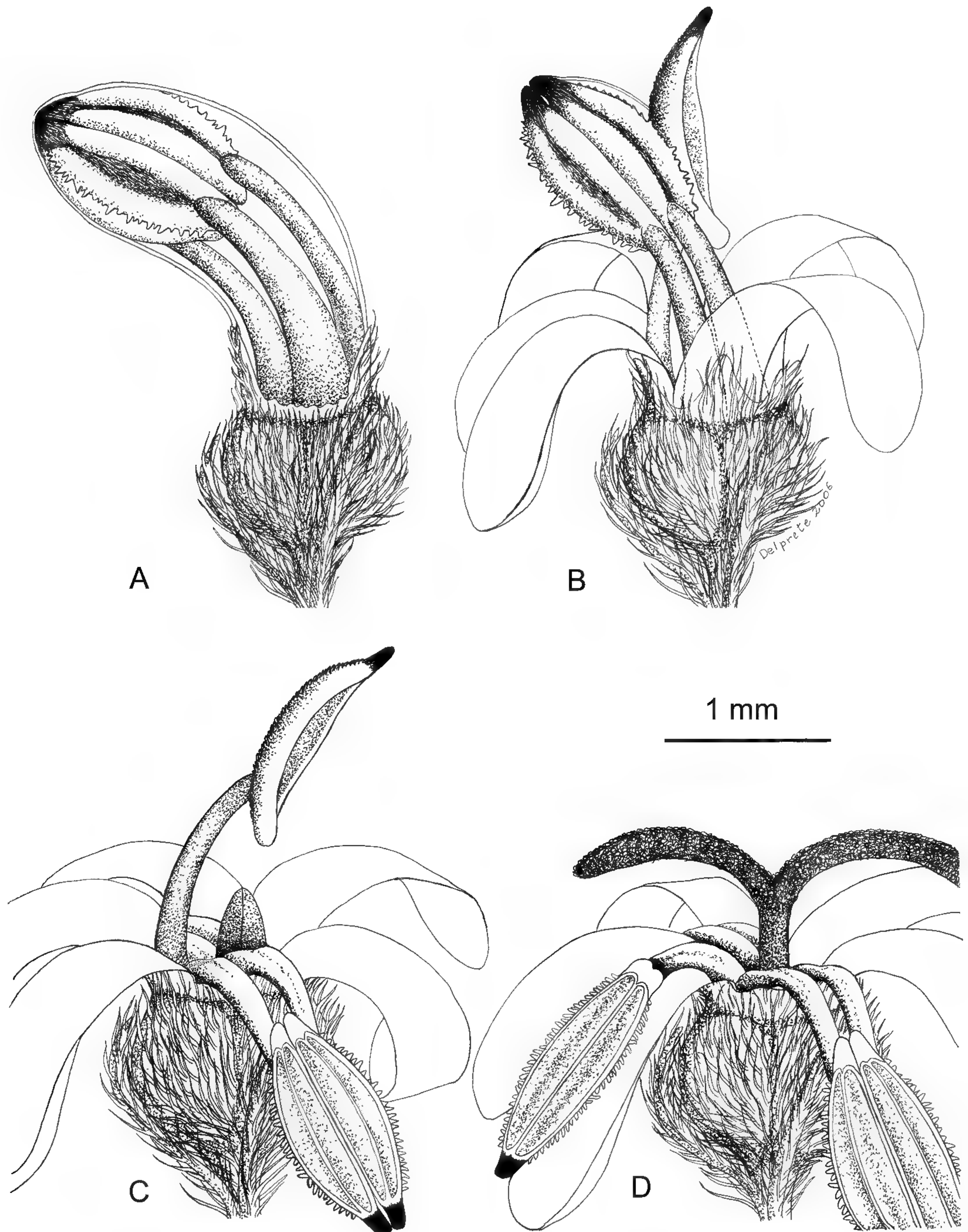

Figure 2. Stages of anthesis of *Molopanthera*. —A. Flower bud, with anthers held in ellipsoidal structure. —B. Pollen catapult mechanism. —C. Stage following the pollen catapult, with the two stamen pairs folded backward and the solitary stamen remaining erect above the corolla mouth. —D. Final stage with solitary anther folded backward and the style branches expanded and receptive.

tube, as it can be seen in the flower bud (Fig. 3A). Each anther has two basal and two apical appendages, which are sterile extensions of the thecae, usually much darker. These function as a contact zone for the

two anther couples. The anthers dehisce longitudinally and, while they are still united, they release a loose pollen mass at the center of the structure (Puff et al., 1995: fig. 14E). Müller (1866) and Puff et al.

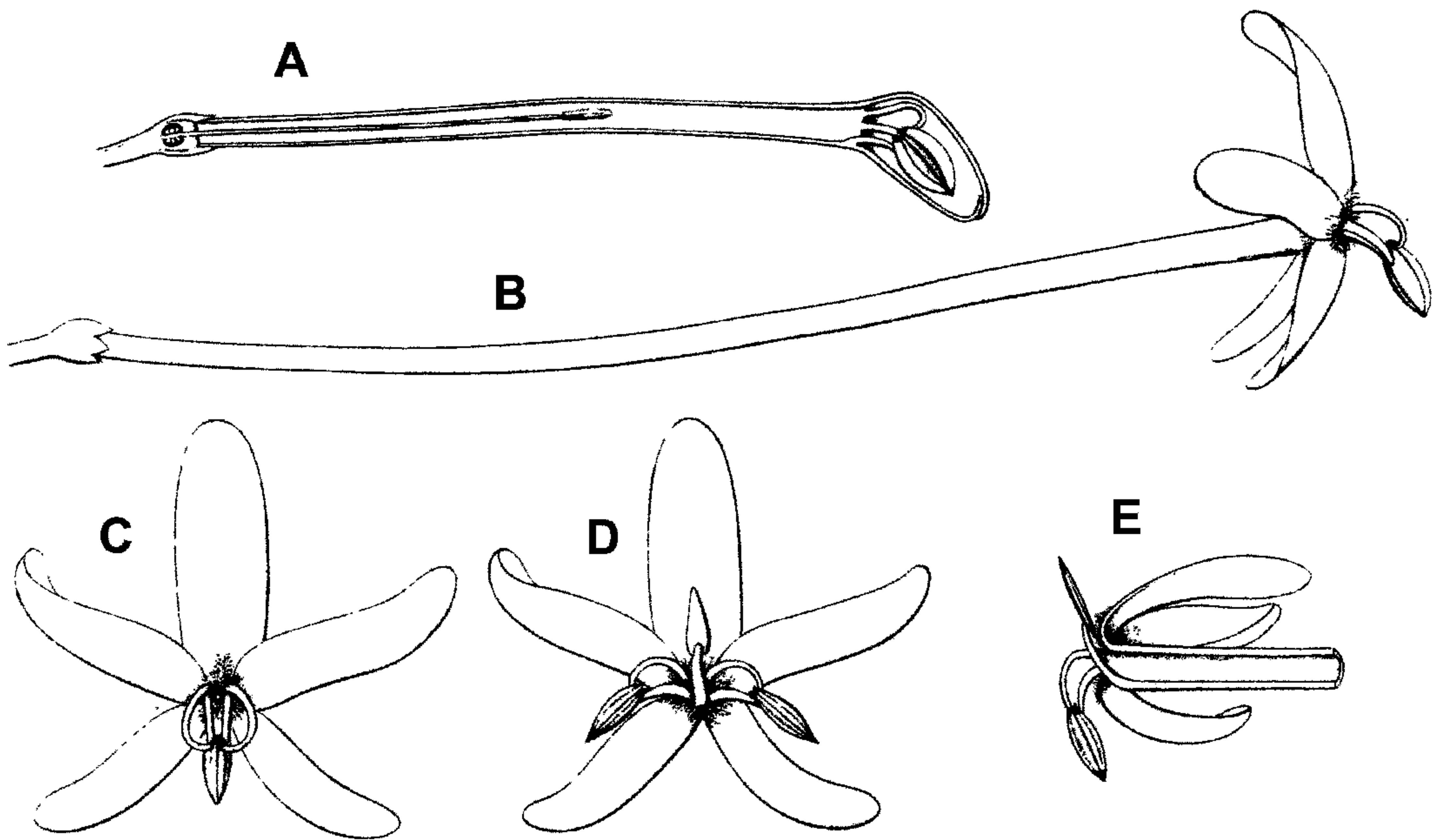

Figure 3. *Posoqueria latifolia*, diagrammatic representation of the pollen catapult mechanism. —A. Flower bud, with anthers in ellipsoidal structure. —B, C. Anthers held in ellipsoidal structure above the corolla. —D, E. Stage following the pollen catapult, with the two lateral stamen pairs folded backward, and the solitary stamen remaining erect above the corolla mouth. (Modified from F. Müller, 1866.)

(1995) reported that the anther structure points downward, as the flowers are pendulous; however, according to personal observation, they might also point upward or sideways, especially in some other species that may also have erect flowers (e.g., *P. gracilis* (Rudge) Roem. & Schult.; pers. obs. in Suriname). The corolla may open prior to pollination, exposing the anther ellipsoid structure (Fig. 3B, C), or may remain closed, with the anther structure enclosed inside the corolla lobes; this variation is possible even within the same individual (e.g., *P. latifolia*; pers. obs. in Santa Catarina). In flowers with the ellipsoid structure exposed, as soon as the hawkmoth touches the anther structure, the ventral stamen makes a violent forward movement (Fig. 3D, E), throwing a dust (or minute clumps of grains) of pollen onto the visitor (pers. obs.; not a globose mass, as reported by Hallé [1967]). In flowers with the anther structure included, it was observed that some hawkmoths forced the entrance of their proboscis at the top of the flower bud (pers. obs.), causing the corolla lobes to open and resulting in the sudden movement of the catapulting anther, releasing a dust of pollen onto the hawkmoth. At the moment of throwing the pollen, the two lateral pairs of anthers remain momentarily erect, folding backward shortly after, with the solitary stamen remaining erect above the corolla mouth. This stage has the obvious function of preventing the visitation of potential pollinators, as the flower at this point is devoid of pollen and the

stigma is not yet receptive. The third stage of anthesis is represented by the solitary anther folding backward (in ventral position), probably due to cell shrinkage, which liberates the mouth of the corolla. This is followed by the expansion of the style and a final receptive stage, with the style either remaining included (e.g., *P. latifolia*, pers. obs.) or further elongating and becoming exerted (e.g., *P. longiflora*, pers. obs. in Ecuador, Suriname, and the Brazilian state of Tocantins), depending on the species. The same catapult mechanism described in *P. latifolia* was also observed and photographed in *P. longiflora* (Fig. 4A, B).

Molopanthera paniculata is a species becoming quite rare in nature, as the Brazilian Atlantic forest is now almost completely destroyed. I was able to find a healthy population at the Feliciano Miguel Abdala Natural Heritage Private Reserve (also known as the "Caratinga Biological Station"), in Minas Gerais, Brazil. Studies on the pollination biology of this genus are planned for the near future. The pollen catapult mechanism of *Molopanthera* was personally observed for the first time at this locality, and although the flowers are much smaller, the process is practically identical to that in *Posoqueria*. The five anthers are initially united into an ellipsoidal structure held at an oblique position, as the flower bud is curved (Fig. 2A). As in *Posoqueria*, each anther has basal and apical appendages, which are sterile extensions of the thecae, much darker, and which function as a

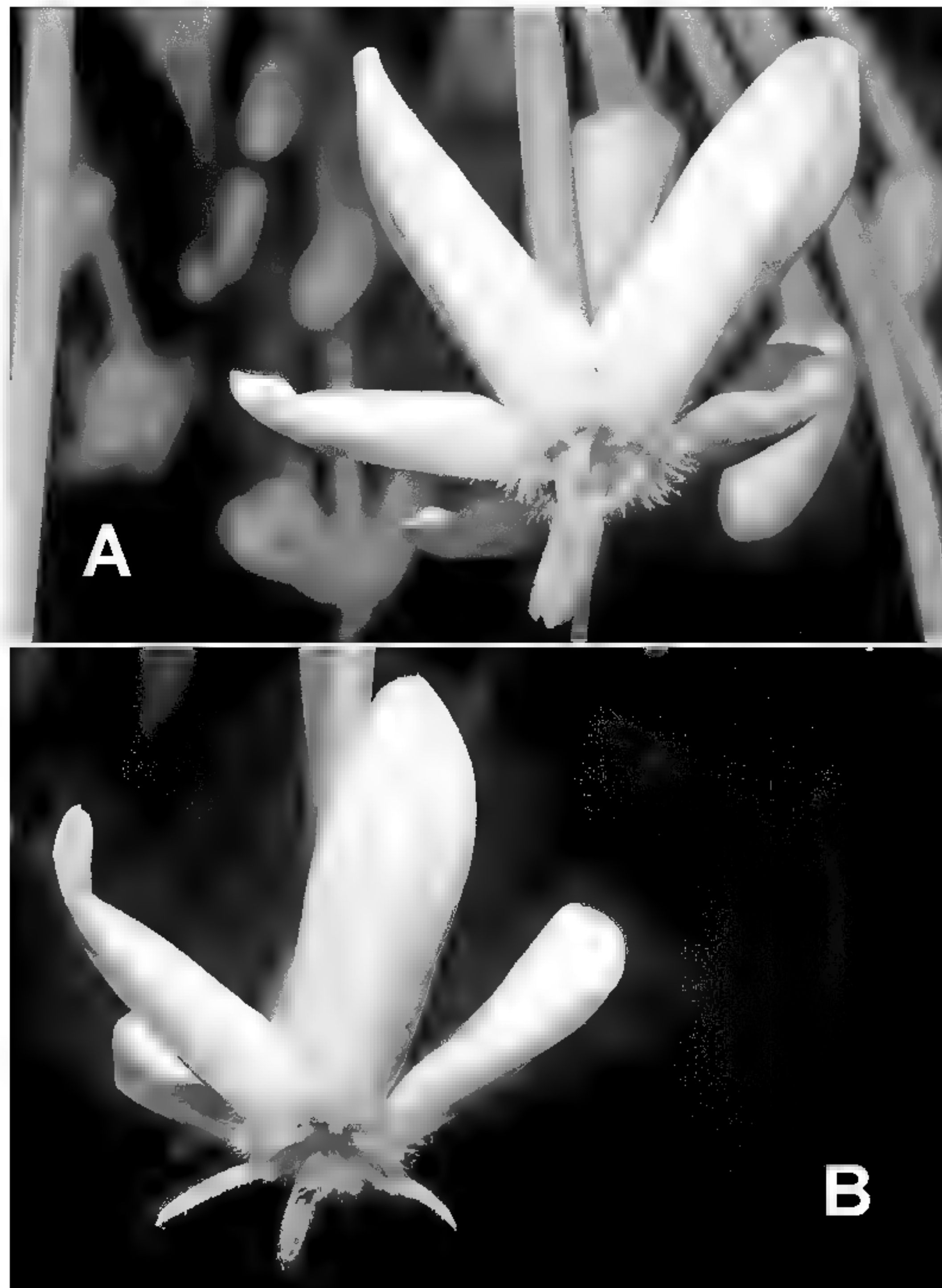

Figure 4. *Posoqueria longiflora*, flowers in two stages of anthesis. —A. Flower with anthers held in ellipsoidal structure above the corolla, before the pollen catapult. —B. Later stage of anthesis following the pollen catapult, with the two lateral stamen pairs folded backward and the solitary stamen folded backward liberating the corolla mouth; the style is in the process of expansion and is still included within the corolla tube. (Photos by L. Westra.)

contact zone for the two anther pairs. While still united, the anthers dehisce longitudinally and release a loose pollen mass at the center of the anther structure. When the visitor (most probably a small bee) touches the anther structure, the ventral stamen springs forward (Fig. 2B), throwing a dust of pollen, while the two lateral pairs of anthers remain momentarily erect. However, the flowers were not directly observed while visited by the pollinators, but the catapult movement was stimulated by lightly touching the tip of the flower buds with a small pin. Shortly after the catapult movement, the two lateral stamen pairs fold outward, and the solitary stamen remains erect above the corolla mouth (Fig. 2C). As in *Posoqueria*, the erect stamen has the function of obstructing the visitation of possible pollinators, as the flower at this point is devoid of pollen and the stigma is not yet receptive. At the final stage of anthesis, the solitary stamen shortens and folds backward, liberating the mouth of the corolla, and the style and style branches expand, exposing the receptive stigmas (Fig. 2D).

POLLEN

According to the information provided by Persson (1993) and Huysmans et al. (1999), the pollen grains of *Molopanthera* (Fig. 1D) and *Posoqueria* (Fig. 1F) are very similar. They are spheroidal (or oblate), tricolporate, and with ectocolpi acute at both ends. The exine is reticulate with lumina gradually decreasing in size toward the poles, and suprategal processes are absent. However, this combination of characters is one of the most common in the family. The main difference between the pollen of the two genera is found in the size, $34\text{--}57 \times 40\text{--}59 \mu\text{m}$ in *Posoqueria* (Persson, 1993) and $14\text{--}16 \times 14\text{--}17 \mu\text{m}$ in *Molopanthera* (Huysmans et al., 1999), which is positively correlated with the flower size in each genus.

OVARY

In both genera, the ovary is 2-locular (sometimes with incomplete placenta and 1-locular in *Posoqueria*), the placenta has a basal stalk, elevating the portion where the ovules are attached to the central septum, and the ovules are numerous. The placental extensions are quite different, terminating with two lateral lamellas in *Posoqueria*, and with a globose structure in *Molopanthera*.

STYLE

The style of *Posoqueria* is bilobed with oblong-ovate stigmatic branches. In most species, it elongates in the female stage of the flower, becoming exerted and receptive after the anthers have folded backward. However, in some species (e.g., *P. tarairensis*), the style apparently remains included even during the receptive stage.

Similarly, the style of *Molopanthera* is bilobed, with the stigmatic branches narrowly oblong and slightly reflexed at maturity (Fig. 2D). It functions much in the same way as that of *Posoqueria*. However, with the first stage of anthesis, the style is about the same length as the corolla tube and not receptive. After the anthers have folded backward, the style expands and the style branches eventually elongate and become receptive.

FRUITS

Aside from the flower size, the most impressive difference between *Posoqueria* and *Molopanthera* lies in fruit size, seed type, and dimensions. Obviously, this set of characters influenced most rubiologists in keeping the two genera far apart in all historical classifications.

The fruits of *Posoqueria* are leathery or woody berries, globose, ovoid to ellipsoid, and 2.5–5 cm in diameter. The large seeds are found in the central portion, immersed in a white, gelatinous pulp.

The fruits of *Molopanthera* are capsular, 2–3.5 × 3.5–5 mm, thin, woody, strongly bilobed, with the two sides subglobose, and with loculicidal dehiscence.

SEEDS

The seeds of *Posoqueria* are attached to the two lamellar extensions of the placenta, which is somewhat difficult to detect in mature fruits. They are 6–15 mm in diameter, round or ovate in outline, obtusely angled or flattened. According to Persson (1995), the exotesta cells are isodiametrical to elongate and parenchymatic. Following personal observations, the seeds are perlaceous, with the outer portion of gelatinous consistency, sweetish and edible, and dispersed by birds (e.g., parrots, pers. obs.) and mammals (e.g., monkeys, capivaras, pers. obs.).

The seeds of *Molopanthera* are peltately attached to the globose placental extensions. They are 0.8–3 × 1–2.2 mm, very irregular, deeply fringed in outline, with a central hylum, and wind dispersed. The testa is shallowly reticulate. Exotesta cells are elongated, with radial orientation, and interspaces have foveolate-reticulate thickenings (Delprete, 1999: 38, fig. 11B). Because of these features, they are very similar to those of *Chimarrhis*, which explains Delprete's (1999) positioning within the Rondeletieae.

CONCLUSION

As discussed here, apparently not all the species of *Posoqueria* display the catapult mechanism typical of this tribe. In the species reported to have stamens with equal length, the flower buds are supposedly straight, as can be seen in the illustration of *P. taraiensis* (Taylor & Cortés-B., 1999: fig. 1), and not laterally bent, as in species with the pollen catapult mechanism. This feature definitely needs further morphological, anatomical, and phylogenetic studies in order to detect patterns of evolution within the genus. Additional field observations of both *Posoqueria* and *Molopanthera* are necessary for a complete understanding of the pollination biology and the identification of the pollinators of this peculiar tribe.

This work corroborates that the pollen catapult mechanism of *Molopanthera* and *Posoqueria* is generally identical, as originally pointed out by Schumann (1888, 1889, 1891). This confirms the close relationship between the two genera.

Literature Cited

- Andersson, L. & C. Persson. 1991. Circumscription of the tribe Cinchoneae (Rubiaceae)—A cladistic approach. *Pl. Syst. Evol.* 178: 65–94.
- Aublet, J. B. C. F. 1775. *Posoqueria*. Pp. 133–136, fig. 52 in *Histoire des Plantes de la Guiane Française*. P.-F. Didot jeune, Paris.
- Baillon, H. E. 1880. Rubiacées–Dipsacacées. Pp. 257–503 in *Histoire Naturelle des Plantes*, Vol. 7. L. Hachette et Cie, Leipzig, Paris.
- Bawa, K. S. & J. H. Beach. 1983. Self-incompatibility systems in the Rubiaceae of a tropical lowland wet forest. *Amer. J. Bot.* 70: 1281–1288.
- Beach, J. 1983. *Posoqueria latifolia* (Boca de Vieja, Guayaba de Mico, Fruta de Mono). Pp. 307–308 in D. H. Janzen (editor), *Costa Rican Natural History*. University of Chicago Press, Chicago.
- Boom, B. M. & P. G. Delprete. 2002. Rubiaceae. Pp. 606–649 in S. A. Mori et al. (editors), *Guide to the Vascular Plants of Central French Guiana, Part 2: Dicotyledons*. *Mem. New York Bot. Gard.* Vol. 76(2).
- Bremekamp, C. E. B. 1934a. Notes on the Rubiaceae of Surinam. *Recueil Trav. Bot. Neerl.* 31: 248–308.
- . 1934b. Rubiaceae. Pp. 113–298 in A. Pulle (editor), *Flora of Suriname*, Vol. 4. J. H. de Bussy Ltd., Amsterdam.
- . 1937. Rubiaceae (additions and corrections). Pp. 475–491 in A. Pulle (editor), *Flora of Suriname*, Vol. 4(1). J. H. de Bussy Ltd., Amsterdam.
- . 1966. Remarks on the position, the delimitation, and the subdivision of the Rubiaceae. *Acta Bot. Neerl.* 15: 1–33.
- Burk, M. W. 1884. Sur l'organisation florale chez quelques Rubiacées. *Ann. Jard. Bot. Buitenzorg* 4: 12–87.
- Candolle, A. P. de. 1830. Rubiaceae. Pp. 341–622 in *Prodromus*, Vol. 4. Treuttel & Würtz, Paris.
- Cortés-B., R., P. G. Delprete & T. J. Motley. 2005. Phylogenetic analysis of the subfamily Ixoroideae (Rubiaceae), with a focus on the controversial systematic position of some genera. XVII International Botanical Congress. Program and Abstracts. Austria Center (17–23 July 2005), Vienna.
- Darwin, C. 1876. *The Effects of Cross and Self-fertilisation in the Vegetable Kingdom*. J. Murray, London.
- . 1877. *The Different Forms of Flowers on Plants of the Same Species*. J. Murray, London.
- Delprete, P. G. 1993. Proposed circumscription of the tribes Chiococceae, Condamineae, and Catesbaeeae using morphological characters [poster]. Program and Abstracts, p. 26. International Conference on the Systematics of the Rubiaceae (4–6 Oct. 1993), St. Louis.
- . 1996. Evaluation of the tribes Chiococceae, Condamineae, and Catesbaeeae (Rubiaceae) based on morphological characters. *Opera Bot. Belg.* 7: 165–192.
- . 1999. Rondeletieae (Rubiaceae), Part I. *Fl. Neotr. Monogr.* 77: 1–226.
- . 2004. Posoquerieae. P. 23 in P. G. Delprete, L. B. Smith & R. B. Klein, *Rubiáceas*, Vol. 1—Gêneros de A–G: 1. *Alseis até 19. Galium* (A. Reis, editor), *Flora Ilustrada Catarinense*. Herbário Barbosa Rodrigues, Itajaí, Santa Catarina, Brazil.
- & R. Cortés-B. 2004. A phylogenetic study of the tribe Sipaneeae (Rubiaceae, Ixoroideae), using *trnL-F* and ITS sequence data. *Taxon* 53: 347–356.

- , T. M. Schuster & P. Hiepko. 2005a. An annotated and liberal translation of Karl Schumann's (1888) "Über einige verkannte oder wenig gekannte Geschlechter der Rubiaceen Südamerikas" ["About some misunderstood or little-known taxa of South American Rubiaceae"] with notes on the Rubiaceae type specimens kept at the Berlin Herbarium. *Bot. Jahrb. Syst.* 126(1), 3–69.
- , L. B. Smith & R. B. Klein. 2005b. Rubiaceae, Vol. 2—Gêneros de G–Z: 20. *Gardenia* até 46. *Tocoyena* (com observações ecológicas por R. Klein, A. Reis & O. Iza). Pp. 345–843 in A. Reis (editor), *Flora Ilustrada Catarinense*. Herbário Barbosa Rodrigues, Itajaí, Santa Catarina, Brazil.
- Hallé, F. 1967. Étude biologique et morphologique de la tribu des Gardeniées (Rubiaceae). *Mem. O.R.S.T.O.M.* 22: 1–146.
- Hooker, J. D. 1873. Ordo LXXXIV. Rubiaceae. Pp. 7–151 in G. Bentham & J. D. Hooker (editors), *Genera Plantarum*, Vol. 2. Lovell Reeve & Co., London.
- Huysmans, S., E. Robbrecht, P. G. Delprete & E. Smets. 1999 [2000]. Pollen morphological support for the Catesbaeeae–Chiococceae–*Exostema* complex (Rubiaceae). *Grana* 38: 325–338.
- Karsten, H. 1849. *Stannia*. Pp. 27–30, tab. 9 in *Auswahl neuer und schön blühender Gewächse Venezuela's*. Verlag der Deckerschen geheimen Ober-Hofbuchdruckerei, Berlin.
- . 1856. *Plantae columbianae*. *Linnaea* 28: 241–546.
- . 1860. *Stannia metensis*. Pp. 51–52, pl. 25 in *Florae Columbiae*, Vol. 1. Ferdinandi Duemmleri successores, Berlin.
- . 1887. Bentham-Hooker's "Genera Plantarum" un *Florae Columbiae* specimina selecta. *Bot. Jahrb. Syst.* 8: 354–360.
- Macias, L. 1988. Revisão Taxonômica do Gênero *Posoqueria* Aubl. (Rubiaceae). Master's Thesis, Universidade Estadual de Campinas, São Paulo.
- & L. S. Kinoshita. 2003. A new species of *Posoqueria* from Bahia, Brazil. *Novon* 13: 206–208.
- Müller, F. 1866. Über die Befruchtung der *Martha* (*Posoqueria*?) *fragrans*. *Bot. Zeitung* (Berlin) 23: 129–133, tab. 6, fig. A.
- Persson, C. 1993. Pollen morphology of the Gardenieae–Gardeniinae (Rubiaceae). *Nord. J. Bot.* 13: 561–582.
- . 1995. Exotesta morphology of the Gardenieae–Gardeniinae (Rubiaceae). *Nord. J. Bot.* 15: 285–300.
- . 1996. Phylogeny of the Gardenieae (Rubiaceae). *Bot. J. Linn. Soc.* 121: 91–109.
- Planchon, J. E. 1850. *Posoqueria formosa*. Pp. 169–171, pl. 587 in L. B. van Houtte (editor), *Flore de Serres et des Jardins de l'Europe*, Vol. 6. Chez Luis Van Houtte, Gent.
- Puff, C., A. Igersheim, R. Buchner & U. Rohrhofer. 1995. The united stamens of Rubiaceae. Morphology, anatomy; their role in pollination ecology. *Ann. Missouri Bot. Gard.* 82: 357–382.
- Robbrecht, E. 1988. Tropical woody Rubiaceae. Characteristic features and progressions. Contributions to a new subfamilial classification. *Opera Bot. Belg.* 1: 1–271.
- . 1993 [1994]. Supplement to the 1988 outline of the classification of the Rubiaceae. Index to Genera. Pp. 173–196 in E. Robbrecht (editor), *Advances in Rubiaceae Macrosystematics*. *Opera Bot. Belg.* Vol. 6.
- & J.-F. Manen. 2006. The major evolutionary lineages of the coffee family (Rubiaceae, angiosperms). Combined analysis (nDNA and cpDNA) to infer the position of *Coptosapelta* and *Luculia*, and supertree construction based on *rbcL*, *rps16*, *trnL-trnF*, and *atpB-rbcL* data. A new classification in two subfamilies, Cinchonoideae and Rubioideae. *Syst. Geogr. Pl.* 76: 85–146.
- & C. Puff. 1986. A survey of the Gardenieae and related tribes. *Bot. Jahrb. Syst.* 108: 63–137.
- Rova, J. H. E., P. G. Delprete, L. Andersson & V. A. Albert. 2002. A *trnL-F* cpDNA sequence study of the Condamineae–Rondeletieae–Sipaneeae complex with implications on the phylogeny of the Rubiaceae. *Amer. J. Bot.* 89: 145–159.
- Schumann, K. 1888. Über einige verkannte oder wenig gekannte Geschlechter der Rubiaceen Südamerikas. *Bot. Jahrb. Syst.* 10: 302–363.
- . 1889. Rubiaceae, trib. X–XIX. Pp. 125–466 in C. F. P. von Martius & A. G. Eichler (editors), *Flora Brasiliensis*, Vol. 6(6). Fleischer, Leipzig.
- . 1891. Rubiaceae. Pp. 1–156 in A. Engler & K. Prantl (editors), *Die natürlichen Pflanzenfamilien*, Vol. 4(4). Engelmann, Leipzig.
- Steyermark, J. A. 1974. Rubiaceae. Pp. 1–2070 in T. Lasser & J. A. Steyermark (editors), *Flora de Venezuela*, Vol. 9. Instituto Botánico, Caracas.
- Taylor, C. M. & R. Cortés-Ballén. 1999. Una especie nueva de *Posoqueria* (Rubiaceae) de la Guyana Colombiana. *Novon* 9: 428–430.
- Turczaninow, N. S. 1848. *Molopanthera*. Decades Quarta et Quinta, generum adhuc non descriptorum. *Bull. Soc. Imp. Naturalistes Moscou* 21: 580–581.
- Verdcourt, B. 1958. Remarks on the classification of the Rubiaceae. *Bull. Jard. Bot. État. Bruxelles* 28: 209–281.

FOSSIL RECORD OF THE RUBIACEAE

Alan Graham^{1,2}

ABSTRACT

Fossils of 134 taxa attributed to the Rubiaceae are described or mentioned in 115 publications dating from 1850 and from deposits as old as the Cretaceous and Paleocene. Close scrutiny of these records indicates, however, that the oldest and most likely (accepted) representatives of the family are four genera, *Emmenopterys* Oliv. from the Middle Eocene of Oregon and Washington, U.S.A., *Faramea* Aubl. from the Late Eocene of Panama, and *Guettarda* L. (cf. as †*Guettardidites*; †— fossil taxon) and *Canthium* Lam. (as †*Rubipollis oblatum*) from the Late Eocene of Australia, and a probable fifth genus, the alternate-leaved †*Paleorubiaceophyllum eocenicum* from the Middle Eocene of Tennessee/Kentucky, U.S.A. The record represents three subfamilies (Rubioidae, Ixoroideae, Cinchonoideae) from three widely separated geographic regions, implying an earlier origin in the Late Cretaceous or Paleocene. From the Oligocene, there are six accepted genera, *Coprosma* J. R. Forst. & G. Forst., *Coprosma-Opercularia*, *Faramea* Aubl., *Macrosphyra* Hook. f. (as †*Triporetetradites hoekeni*), *Mitragyna* Korth. (as †*Retitricolporites annulatus*), and *Pinckneya* Michx. from Africa (Cameroon), Australia and New Zealand, U.S.A. (Oregon), and Puerto Rico. The period of greatest diversification and radiation was in the Miocene, with 20 accepted genera reported from North America, Central America, South America, Southeast Pacific-Asia, Africa, and Europe. Stages in the evolution of three characters are further suggested by the fossil record. The relatively uncommon occurrence of alternate leaves among modern taxa is typical of advanced genera (e.g., *Didymochlamys* Hook. f., *Sabicea* Aubl., *Theligonum* L.), but this feature may have already developed by the Middle Eocene (†*Paleorubiaceophyllum*). Polyploidy is suggested in the Middle Eocene *P. eocenicum* var. *lawrensis* by epidermal cells 32 µm in diameter or nearly twice the size of the other varieties. Pollen polymorphism, possibly coordinated with or as a prelude to heterostyly, is represented by the diporate pollen of *Faramea* in the Late Eocene, and triporate and tetraporate forms in the Miocene and Pliocene. Currently, the principal needs are: (1) to clarify pending Paleocene records of †*Cinchonidium* (*Cinchona* L.), North Dakota, U.S.A.; *Galium* L., Greenland; and †*Psilatricolpites coprosmoides* (*Coprosma*, Chile); and (2) to examine the several large Cretaceous megafossil floras now under study (e.g., Anfiteatro de Ticó, Argentina; Crato, Brazil; Turonian-age floras, New Jersey and Sweden) for specimens with features that suggest a rubiaceaceous complex or with an aggregation of features suggesting presence of the family.

Key words: Fossils, Rubiaceae.

Reconstructing the fossil history of plant families requires assembling reports often from widely scattered literature dating back centuries. For the Rubiaceae, there are approximately 134 taxa described or mentioned in 115 publications including the earliest ones of Unger (1850, *Canthidium* [Unger spelling], †*Cinchonidium*, Croatia), Wessel and Weber (1855, †*Rubiacites*, Germany), Heer (1868, *Galium* L., Greenland), and others from later in the 1800s and early 1900s. All are accounted for in the present summary, and none have been revised since the original publications. There are other reports in unpublished theses and dissertations, and there is casual, unconfirmed mention of the family as possibly present in some putative Late Cretaceous and older deposits in the literature of the 1800s that also are not included.

These reports must be filtered through at least a preliminary assessment to yield a database of plausible records. The procedure for evaluating the fossil pollen records of extant angiosperms used here is similar to that of Muller (1981). In this informal rating, "A" (accepted) means that: (1) the specimens have been reexamined and are considered to represent the Rubiaceae; or (2) the specimens are sufficiently diagnostic to allow recognition to genus or family from the illustrations and/or descriptions (e.g., the dimorphic pollen of *Faramea* Aubl.); and (3) the identification does not pose improbable age, phylogenetic, paleoecologic, or biogeographic problems to the extent this context information is available for the taxon and the locality. "P" (pending) means additional information (e.g., more accurate age determination, better

¹The author is grateful for information on the classification and distribution of modern Rubiaceae provided by Elmar Robbrecht and Charlotte Taylor, and on the status of fossil *Emmenopterys* by Steven Manchester. Other information on the fossils, repositories, and literature was provided by Lea Grauvogel-Stamm, Leo Hickey, Miklos Kedves, Linda Klise, Jeri Kvacek, Gengwu Liu, Dieter Mai, Helene Martin, Rosemary Paull, Wesley Wehr, Scott Wing, and Jon Wingerath. Permission to use copyrighted material is acknowledged in the legends. Victoria C. Hollowell and the staff of the Missouri Botanical Press provided many helpful suggestions that improved the manuscript. The library staff at the Missouri Botanical Garden was particularly effective in locating difficult-to-find publications, and special thanks goes to Mary Stiffler. The manuscript was read by Shirley A. Graham, Maria C. Zamalao, and one anonymous reviewer. The project was suggested by Piero Delprete.

²Missouri Botanical Garden, P.O. Box 299, St. Louis, Missouri 63166-0299, U.S.A. alan.graham@mobot.org.

doi: 10.3417/2006165

preserved or more complete specimens), and/or confirmation through reexamination of the material is needed. "NA" (not accepted) means: (1) only casual reference is made to family affinities (e.g., the fossil pollen named *Tricolporopollenites arnotiensis* that Scholtz [1985] compared to *Anthospermum* L., *Nenax* Gaertn., and *Rubia* L., as well as to the Euphorbiaceae and Bombacaceae); or (2) features are present that are not found in or characteristic of the family. These assessments are by the present author, unless otherwise indicated. The abbreviations are also explained the first time they are used in the Synopsis section.

Another step in reconstructing an accurate geologic history for a family is to identify the location of specimens presently rated as pending. Finally, reexamination of this material will eventually be necessary by those familiar with leaf, floral, seed/fruit, wood, and pollen morphology of extant species, and the phylogenetic and biogeographic implications of the reports. Such pending material for the Rubiaceae includes the leaf †*Cinchonidium ovale* from the Paleocene of North Dakota, U.S.A., the fruit *Galium* †*antiquum* from the Paleocene of Greenland, and the pollen †*Psilatricolpites coprosmoides* (*Coprosma* J. R. Forst. & G. Forst.) from the Oligocene to Recent of New Zealand (A) and reported from the Paleocene of Chile (P). In the following summary, abbreviations for the repositories of specimens (not *Index Herbariorum* abbreviations [Holmgren & Holmgren, 1998]), or author affiliation at the time of publication, are as follows: ASNU, Australian National University, Canberra, Australia; CNRS, Centre National Recherche Scientifique, Paris, France; FLMNH, Florida Museum of Natural History, Gainesville, Florida, U.S.A.; FSTS-J, Faculté Sciences Techniques St.-Jérôme, Marseille, France; GIL, Geological Institute, Leiden, The Netherlands; GSC, Geological Survey of Canada, Calgary, Canada; GSV, Geological Survey of Victoria, Victoria, Australia (as of 2004, GeoScience Victoria); JVG, Josephinum Vienna/Graz, Austria; MACN, Museo Argentino de Ciencias Naturales "Bernardino Rivadavia," Buenos Aires, Argentina; MO, Missouri Botanical Garden, St. Louis, Missouri, U.S.A. (the author's modern spore and pollen reference collection, fossil collection, literature collection, and associated materials are currently being transferred to the Smithsonian Tropical Research Institute, Panama); MPUC, Museum of Paleontology, University of California, Berkeley, California, U.S.A.; NIGP, Nanjing Institute of Geology and Paleontology, People's Republic of China; NMP, National Museum, Prague, Czech Republic; NTU, National Taiwan University, Taipei, Taiwan; NZGS, New Zealand Geological Survey, Lower Hunt, New Zealand; RN-D, Realgym-

nasium zu Neustadt-Dresden, Germany; RRNA, Robertson Research (North America), Calgary, Alberta, Canada; SAMC, South African Museum, Cape-town, South Africa; SM, Senckenberg Museum, Frankfurt am Main, Germany; SOCDH, Shell Oil Company, Den Hague, The Netherlands; SUPA, Stanford University, Palo Alto, California, U.S.A.; UA, University of Amsterdam, Amsterdam, The Netherlands; ULP, Université Louis Pasteur, Strasbourg, France; UPMC, Université Pierre et Marie Curie, Paris, France; USGS, U.S. Geological Survey, Denver, Colorado, U.S.A.; USNM, U.S. National Museum (Paleobiology Division), Washington, D.C., U.S.A.; UNSWK, University of New South Wales, Kensington, Australia; UVA, University of Vienna, Vienna, Austria; VGS, Vermont Geological Survey, Waterbury, Vermont, U.S.A.; ZOOZ, Zoological Museum, University of Zurich, Zurich, Switzerland; ZGIB, Zentrales Geologisches Institut, Berlin, Germany. Abbreviations for repositories are provided at the end of each summary, followed by abbreviations for status. Superscript numbers in text denote the following: 1, Early Miocene fide Berry (1938), Early Eocene fide Romero (1986: 454), age unsettled. 2, Rubiaceae affinities not cited by authors, only implied by the etymology of the generic names (see Andrews, 1970; Blazer, 1975; Watt, 1982). 3, *Anisomeris* C. Presl, *Chomelia*, *Guettarda*, *Terebraria* et al. type. 4, Eocene fide Romero (1986: 453), Paleocene fide Palma-Heldt (1980).

A SYNOPSIS OF REPORTS OF FOSSIL RUBIACEAE

CRETACEOUS

There are six fossil taxa from the Cretaceous referred to the Rubiaceae that represent four form genera and six species. None have been confirmed as belonging to the family.

1. †*Rubiaephyllum gaylussaciae* Bayer. **Leaf**, Bohemia, Bayer in Fritsch (1893: 131, fig. 192). According to Kvacek (pers. comm., 2006), the morphology and preservation of the specimens in this report make the family assignment uncertain. NMP. NA.
- 2–3. †*Tricolporopollenites arnotiensis* Scholtz (1985: 71, figs. 17d–h) and †*T. brinkiae* Scholtz (1985: 72, figs. 17a–c). **Pollen**, southwest Africa. The beds range in age from 71 Ma (Late Cretaceous) to 64 Ma (Early Paleocene), but because the samples came from the upper part of the section, they are probably Early Paleocene. The specimens are only informally compared by Scholtz (1985) to the Rubiaceae (*Anthospermum*,

Nenax, *Rubia*), as well as to the Euphorbiaceae and Bombacaceae. SAMC. NA.

4–5. †*Triorites aspidatus* and †*T. megaporus* (authors unknown, contact: G. Liu, pers. comm., 2006). **Pollen**, People's Republic of China. Both pollen records provided by G. Liu (pers. comm., 2006). Only informal reference is made to the family by Liu (possibly *Gardenia* J. Ellis). NIGP. NA.

6. †*Triporetadites scabratus* van Hoeken-Klinkenberg (1964: 226, fig. 16). **Pollen**, Nigeria, attributed to *Gardenia* by Krutzsch (1970; as *Gardenia* type). According to Muller (1981), the specimens are too poorly preserved to be recognized as *Gardenia*. GIL. NA.

PALEOCENE

Six fossil taxa are mentioned for the family from the Paleocene, representing five form and modern genera and five species. None have been confirmed as belonging to the Rubiaceae. Three warrant reexamination: *Cinchonidium ovale* Lesq., *Galium antiquum* Heer, and *Psilatricolpites coprosmoides* Couper.

1. †*Cinchonidium ovale* Lesq. (1883: 229, pl. 48, figs. 8–10b). **Leaf**, North Dakota, U.S.A., cf. *Cinchona* L. USNM (the specimen cannot be located in the USNM collections; S. Wing, pers. comm., 2006). P.

2. *Galium* †*antiquum* Heer (1868: 119, pl. 17, figs. 8, 8b; Heer, 1883: 114). **Fruit**, Greenland. ZOOZ. P.

3. †*Psilatricolpites coprosmoides* Couper. **Pollen**, originally recognized as *Coprosma* J. R. Forst. & G. Forst. sp. by Couper (1953: 54, pl. 9, fig. 143, Late Miocene to Recent; 1960: 59, pl. 9, figs. 1–3, Middle Oligocene to Recent) from New Zealand. This pollen type was recognized by Doubringer and Chotin (1975: 559–560, pl. 2, fig. 13) from the Paleocene of Chile, and was said to resemble certain *Coprosma*. There is only a very brief description for the Chile record. Couper, NZGS or SOCDH, Oligocene to Recent, A; Doubringer, ULP, Paleocene, P.

4. †*Retistephanocolpites* Leidelmeyer sp. **Pollen**, tetracolpate, described by Scholtz (1985: 76, fig. 19e–g) from southwestern Africa. Scholtz (1985: 76) notes that “No positive suggestions can be made regarding the affinity of *Retistephanocolpites* sp. The pollen of *Rubia* (Rubiaceae) and *Catastemma* Benth. (Bombacaceae), amongst

others, appear superficially similar to this fossil species.” SAMC. NA.

5–6. †*Tricolporopollenites arnotiensis* and †*T. brinkiae* from the Arnot Pipe sediments of Late Cretaceous to Early Paleocene age have been mentioned earlier. SAMC. NA.

EOCENE

For the Eocene, 32 fossil taxa (including family reports for the Rubiaceae and the name †*Tricolporé reticulé*) representing 22 form and modern genera and 28 species are mentioned for the Rubiaceae.

1. *Cephalanathus* †*glabratifolius*¹ Berry (1938: 132–133, pl. 54, figs. 3–6). **Leaf**, Argentina. Berry (1938) compares the fossil to *Cephalanathus glabratus* (Spreng.) K. Schum. growing today in Paraguay, Uruguay, and northern Argentina. USNM. P.

2. *Coprosoma* †*incerta*¹ Berry. **Leaf**, Berry (1938: 133, pl. 47, fig. 1), Argentina. USNM. P.

3. *Coprosoma* †*spathulatifolia*¹ Berry. **Leaf**, Berry (1938: 133, pl. 52, figs. 4, 5), Argentina. USNM. P.

4. *Coussarea* †*tertiaria*¹ Berry. **Leaf**, Berry (1938: 131, pl. 53, fig. 5), Argentina. USNM. P.

5. †*Cricotriporites camerounensis* Sal.-Cheb. **Pollen**, Salard-Cheboldaeff (1978: 246, pl. 6, fig. 4), Late Eocene to Early Miocene, Cameroon. Salard-Cheboldaeff (1978) compared the fossil to *Randia uliginosa* DC., but this is regarded doubtful by Muller (1981). UPMC. NA.

6. cf. *Emmenopterys* Oliv. **Fruit**, Middle Eocene Republic flora (49–48 Ma), Washington, U.S.A. (Wehr & Manchester, 1996: 25, pl. 2, fig. 6). FLMNH. A.

7. *Emmenopterys* †*dilcheri* Manchester (Fig. 1A, B). **Infructescence and fruit**, Middle Eocene Clarno flora (44 Ma), Oregon, U.S.A. (Manchester, 1994: 80–81, pl. 36, figs. 1–11). The extant *Emmenopterys henryi* Oliv. of People's Republic of China is mentioned as similar by Manchester (1994) and Wehr and Manchester (1996). FLMNH. A.

8. *Exostema* †*pseudocaribaeum* Berry (1916: 349, pl. 106, fig. 3). **Leaf**, Middle Eocene, Tennessee/Kentucky, U.S.A. When originally described, Berry (1916) thought the Wilcox Formation was Early Eocene, but it is now considered Middle Eocene. Similarity is cited by Berry with

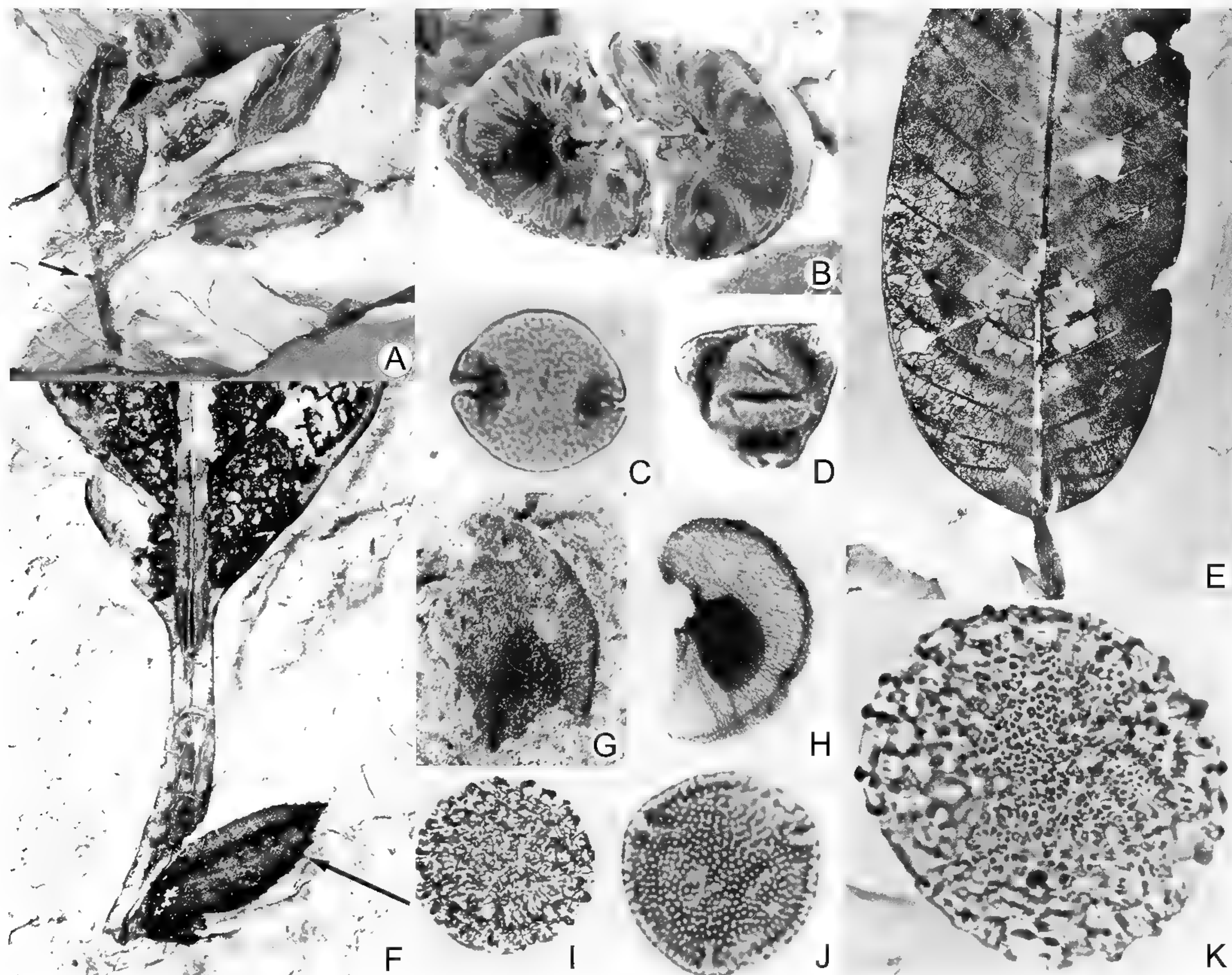

Figure 1. A, B. *Emmenopterys dilcheri* Manchester from the Middle Eocene Clarno flora, Oregon, U.S.A. —A. Infructescence. —B. Fruit. A, B from Manchester (1994), used with permission of the Paleontological Research Institution, Ithaca, New York, U.S.A., and the author. —C. *Faramaea* pollen, diporate form, from the Late Eocene Gatuncillo flora, Panama, from Graham (1985). —D. *Faramaea* pollen, triporate form, from the Middle Pliocene Paraje Solo flora, Veracruz, Mexico, from Graham (1976). —E, F. *Paleorubiaceophyllum eocenicum* (Berry) Roth & Dilcher from the Middle Eocene Claiborne flora, Tennessee/Kentucky, U.S.A. Reprinted with permission from Roth and Dilcher (1979). —G. *Pinckneya dilcheri* Meyer & Manchester from the Oligocene Bridge Creek flora, John Day Formation, Oregon, U.S.A. —H. *Pinckneya pubens* Michx., modern seed, from Meyer and Manchester (1997). Images G, H used with permission of the University of California Press, Berkeley, California, U.S.A., and the author (Manchester). —I. *Chomelia* type pollen from the Late Miocene Gatun flora, Panama, from Graham (1991a). —J. *Posqueria* pollen from the Late Miocene Gatun flora, Panama, from Graham (1991a). —K. *Sabicea* pollen from the early Miocene Culebra flora, Panama, from Graham (1988).

the extant *Exostema caribaeum* (Jacq.) Roem. & Schult. of the Caribbean region. USNM. P.

9. *Faramaea* Aubl. **Pollen**, distinctive diporate form, Late Eocene Gatuncillo flora, Panama, Graham (1985: 9–520, figs. 64, 65; Fig. 1C). MO. A.

10. *Gardenia* type (as †*Triporetetradites nachterstedtensis* Krutzsch (1970: 412, pl. 48, figs. 27–32). **Pollen**, Late Eocene of Germany. ZGIB. A (by Muller, 1981; here P, confirmation needed).

11. *Guettarda* †*ellipticifolia* Berry (1916: 348, pl. 106, figs. 1, 2). **Leaf**, Middle Eocene, Mis-

issippi/Tennessee, U.S.A., Berry (1916) compared to the extant *Guettarda elliptica* Sw. from the Caribbean region. USNM. P.

12–13. cf. †*Guettardidites ivirensis* Khan (1976: 763, fig. 24). **Pollen**, *Guettardidites* sp., MacPhail (1999: 205, pl. 5, fig. 7); **pollen**, Late Eocene to Early Pliocene, Murray Basin, Australia, *Guettarda*. ASNU. A.

14. *Hoffmannia* †*protogaea*¹ Engelh. **Leaf**, Berry (1938: 131, pl. 53, figs. 1, 2), Argentina, P. Berry (1922: 86), Chile⁴. USNM (all). P.

15. †*Ixorophyllum anceps* Geyer (1887: 495, pl. 35, figs. 1, 2). **Leaf**, Eocene, Borneo. Repository unknown. P.
16. †*Paleorubiaceophyllum eocenicum* (Berry) Roth & Dilcher (1979: 1203–1205, figs. 1–22; Fig. 1E, F; *Paleorubiaceophyllum* sp., Dilcher & Lott, 2005: 17–18, fig. 9a, b). **Leaf**, Middle Eocene Claiborne flora of Tennessee/Kentucky, U.S.A. Additional fossil material (branches) has shown that the leaves are alternate (Manchester, pers. obs., 2006). FLMNH. A or P (because of alternate branching?).
17. *Psychotria* †*eogenica* Berry (1929b: 166–167, pl. 3, figs. 17–21). **Seed**, Eocene, Peru. USNM. P.
18. *Psychotria* †*grandifolia* Engelm. **Leaf**, Berry (1916: 349–350, pl. 105, fig. 1), Middle Eocene, Tennessee/Kentucky, U.S.A. Berry (1916) compared this with *Psychotria grandis* Sw. USNM. P. It is also listed (as *Psychotria grandifolia?*) by Berry (1941: 84) but not described or illustrated, **leaf**, Kentucky, U.S.A. USNM. NA.
19. *Psychotria* †*oregona* Chaney & Sanborn (1933: 96, pl. 33, fig. 4). **Leaf**, Eocene, Oregon, U.S.A. Chaney and Sanborn (1933) compared it to the extant *Psychotria undata* Jacq. of the Caribbean region, but the record has not been verified. MPUC. P.
- 20–21. †*Randiapollis microreticulatus* Ke & Shi. **Pollen**, *R. reticulatus* Ke & Shi. **Pollen**, Eocene, People's Republic of China (G. Liu, pers. comm., 2002). Only general affinity to the family suggested by Liu. NIGP. NA.
22. *Remijia* †*tenuiflorifolia*¹ Berry. **Leaf**, Berry (1938: 132, pl. 54, figs. 1, 2), Argentina. USNM. P.
23. *Rondeletia* †*longiflorifolia*¹ Berry. **Leaf**, Berry (1938: 132, pl. 54, figs. 7, 8), Argentina. USNM. P.
24. Rubiaceae type 1 (Graham, 1985: 520, figs. 66, 67). **Pollen**, type 2 (Graham, 1985: 520, figs. 68, 69); **pollen**, Late Eocene, Panama. MO. A (as family).
25. †*Rubiaceocarpum markgrafi* Kräusel (1939: 108, pl. 1, figs. 19–24). **Seed**, Eocene, Egypt. SM. P (as family).
26. †*Rubiacites chomeliifolia*¹ Berry. **Leaf**, Berry (1938: 133–134, pl. 55, figs. 1, 2), Argentina. USNM. P (as family).
27. †*Rubiacites? pellicieraformis* Berry (1930: 134, pl. 49, fig. 19). **Fruit**, Middle Eocene, Tennessee, U.S.A., family but no generic affinity mentioned by Berry (1930). USNM. P.
28. †*Rubiacites sphericus* Berry (1930: 133–134, pl. 45, figs. 9–11). **Fruit**, Middle Eocene, Tennessee/Kentucky, U.S.A., family but no generic affinity mentioned by Berry (1930). USNM. P.
29. †*Rubiacites wilcoxensis* Berry (1930: 133, pl. 45, fig. 8). **Fruit**, Middle Eocene, Tennessee/Kentucky, U.S.A., family but no generic affinity mentioned by Berry (1930). USNM. P.
30. †*Rubipollis oblatum* (Pocknall & Mildenhall) Mildenhall & Pocknall. **Pollen**, MacPhail (1999: 205, pl. 11, figs. 26, 27), Late Eocene to Early Pliocene, Murray Basin, Australia. MacPhail (1999) associated this with *Canthium* Lam. NZGS. A.
31. †*Tricolporé reticulé*, without attribution in Gruas-Cavagnetto (1977). **Pollen**, from the late Eocene and Oligocene, France. This was listed as *Chomelia* Jacq. type in Gruas-Cavagnetto (1978). It is not clear if it can be distinguished from the pollen of other rubiaceous genera fide Muller (1981). UPMC. NA (as Rubiaceae or *Chomelia*).
- †*Triporetadites nachterstedtensis* (see *Gardenia*).
32. †*Uragoga tertiaria* Berry (1929b: 166, pl. 3, fig. 16). **Seed**, Eocene, Peru. USNM. P.

OLIGOCENE

For the Oligocene, 16 fossil taxa representing 17 form and modern genera (including *Tricolporé reticulé*) and 13 species have been assigned or compared with the Rubiaceae.

1. †*Canthiumidites* aff. *bellus* (Stover & Partridge) Mildenhall & Pocknall. **Pollen**, Argentina (Barreda, 1997: 286, pl. 1, figs. 10, 11). Barreda (1997) compares the fossil to *Gardenia* (Old World tropics; see Miocene). MACN. NA.
2. †*Cinchonidium copeanum* (Lesq.) Ettingsh. (1883: 130; Ettingshausen, 1888: 49). **Leaf**, Nevada, U.S.A. Ettingshausen (1883, 1888) compares the fossil to *Cinchona* (Andes). USNM (Lesquereux material), JVG (Ettingshausen material). P.

3. †*Circotroporites camerounensis* (see Eocene).
 4. *Coprosma* type. **Pollen**, New Zealand (Couper, 1960: 59, pl. 9, figs. 1–3). Included in Mildenhall (1980: 215), NZGS. A (fide Mildenhall, 1980).
 5. *Faramea*. **Pollen** (triporate form), Puerto Rico (Graham & Jarzen, 1969: 328, fig. 21). *Faramea* presently grows in tropical America. MO. A.
 6. *Guettarda* †*intercalaris* Hollick (1928: 225, pl. 81, fig. 5b). Line drawing of leaf fragment, Puerto Rico. *Guettarda* presently grows in New Caledonia and tropical America. USNM. P.
 7. cf. †*Guettardidites* Khan (see Eocene).
- Macrosphyra* Hook. f. (see *Tripоротetradites hoekeni*)
8. †*Mitragynaxylon gevinii* Koeniguer & Lemoigne in Gevin et al. (1971: 386–393, text-figs. 1, 2; pl. 23, figs. 1–8). **Wood**, Oligocene and Miocene, Algeria. Laboratoire Géologie Appliquée (Gevin), Laboratoire de Paléobotanique (Lemoigne), Université de Lyon (Université Claude-Bernard); Laboratoire de Paléobotanique, Université de Paris (Koeniguer). P.
 9. †*Naucleaphyllum ovale*² Louvet & Mouton (1970: 82–85, pl. 2). **Leaf**, Libya. Repository unknown. NA.
 10. †*Palaeocoprosmadites zelandiae* Pocknall. **Pollen**, MacPhail (1999: 205, pl. 9, figs. 16, 17), Late Oligocene to Pleistocene, Murray Basin, Australia. MacPhail (1999) compares the fossil to *Coprosma–Opercularia*. ASNU. A.
 11. *Pinckneya* †*dilcheri* Meyer & Manchester (1997: 149, pl. 63, figs. 8–10; Fig. 1G). **Seed**, Oregon, U.S.A. This is an extant genus in the Rubiaceae with one species (*Pinckneya pubens* Michx.; Fig. 1H) in the southeastern U.S.A. FLMNH. A.
 12. †*Psilatricolpites coprosmidis* (see Paleocene).
 13. †*Retitricolporites annulatus* Sal.-Cheb. (1978: 236–238, pl. 4, figs. 7–9). **Pollen**, Cameroon. Salard-Cheboldaeff (1978) compares the fossil to *Mitragyna inermis* (Willd.) Kuntze, which grows in Cameroon. UPMC. A (fide Muller, 1981).
 14. †*Rubioxylon naucleoides* E. Hofm. (1952: 172, pl. 13, fig. 3). **Wood**, Austria. Repository unknown (Vienna, Austria). P.

15. †Tricolporé reticulé (see Eocene).

16. †*Tripоротetradites hoekeni* Sal.-Cheb. (1978: 252, pl. 7, fig. 3). **Pollen**, Cameroon. Salard-Cheboldaeff (1978) compares the fossil to the extant *Macrosphyra longistyla* (DC.) Hiern that grows in Cameroon. UPMC. A (fide Muller, 1981).

MIOCENE

Note that fossils described by Berry (1925, 1938) from Laguna del Hunco and Río Pichileufu, Argentina, and referred by him to the Miocene, are now regarded as Eocene (Romero, 1986; Wilf et al., 2005; Zamaloa, pers. comm., 2008). For the Miocene, 58 fossil taxa representing 46 form and modern genera and 37 species have been assigned or compared with the Rubiaceae.

1. *Borreria* G. Mey. **Pollen**, Médus (1975: 576, pl. 10, fig. 3, pl. 11, figs. 30–32), Senegal. FSTS-J. A.
2. *Bothriospora* †*witii* Engelh. (1895: 30, pl. 6, fig. 6). **Leaf**, Colombia (also Pons, 1985: 241). Pons (1985) compares the fossil with the extant *Bothriospora corymbosa* (Benth.) Hook. f. growing today in Colombia, Ecuador, Guyana, and Peru. RN-D (Engelhardt material), UPMC (Pons material). P (both).
3. *Canthidium* †*radobojanum* Unger (1850: 429). **Leaf**, Croatia. The genus occurs today in the Paleotropics. UVA. P.
4. †*Canthiumidites bellus* (Stover & Partridge) Mildenhall & Pocknall. **Pollen**, MacPhail (1999: 205, pl. 5, figs. 5, 6), Early to Middle Miocene, Murray Basin, Australia; *Canthiumidites* cf. *bellus* Middle Miocene–Early Pliocene, Falkland Islands, MacPhail and Cantrill (2006: 610, table 1; 613, table 3; pl. III, figs. 39, 40); *Randia*. ASNU. A.
5. *Chiococca* P. Browne. **Leaf**, Axelrod (1940: 1979: 32), Mint Canyon flora, southern California, U.S.A. The Mint Canyon flora is found on a terrane transported north from northwestern Mexico along the San Andreas Fault. MPUC. A.
6. *Chomelia* Jacq. type. **Pollen**, Graham (1991a: 212–213, fig. 40; Fig. 11; Graham, 1991b), Panama. MO. A (as the family).
7. †*Cinchonidium racemosum* Unger. **Fruit**, Unger (1850: 430; Unger, 1865: 11, pl. 3, figs. 1, 2, 6), Croatia. UVA. P.

8. †*Condaminea grandifolia* Engelh. (1895: 34, pl. 7, fig. 2; pl. 9, fig. 1). **Leaf** (as Rutaceae), Colombia. RN-D. P; Berry (1919: 293–294, pl. 17), leaf, Peru. USNM. P.
9. *Coprosma* type. **Pollen**, Leopold (1969: 1180, pl. 311, fig. 37), Marshall Islands. USGS. A (as Rubiaceae; see also †*Psilatricolpites coprosmoides*, Paleocene, pollen).
10. *Cosmibuena* Ruiz & Pav. **Pollen**, Graham (1991a: 213, fig. 43; Graham, 1991b), Panama. MO. A.
11. *Coussarea* †*membranacea*^{1,4} Engelh. **Leaf**, Chile (see Tertiary undifferentiated), Berry (1922: 86, listed only), Chile. RN-D (Engelhardt material). P.
12. †*Cricotriporites camerounensis* (see Eocene).
13. †*Elaeagnites campanulatus* Heer. **Calyx**, Heer (1876: 58, pl. 12, fig. 11), Spitsbergen. ZOOZ. P.
14. *Endlicher(i)a rhamnoides* Engelh. **Leaf**, Engelhardt (1895: 12, pl. 1, figs. 7 [as 17 in Engelhardt, 1895 text], 19, 20), Colombia; Berry (1929a: 91, listed only), Ecuador, under Rubiaceae but genus belongs to the Lauraceae. RN-D (Engelhardt material). P.
15. *Exostema* †*precaribaeum* Berry. **Leaf**, Berry (1939a: 132–133, pl. 18, figs. 4, 5), Cuba. USNM. P.
16. *Faramea* types 1, 2, **pollen** (triporate, tetraporate forms), Graham (1991a: 213, figs. 41, 44, 45, 48; 1991b), Panama. MO. A.
17. *Faramea miocenica* Berry. **Leaf**, Berry (1925: 228–230, pl. 7, fig. 4), Argentina (Patagonia). USNM. P.
- Faramea* (see also †*Psilatriporites corstanjei*).
18. †*Favitricolporites magnus* without attribution in Mandaokar (2003: 190, no illustrations, description, referred to Rubiaceae), Mizoram region, northeastern India. Lucknow, India. NA.
19. *Galium* L. **Pollen**, White & Ager (1994: 51, pl. 4, fig. 22), Alaska, U.S.A. GSC, USGS. A.
- Gardenia* (see also †*Triporotetradites letouzeyi*).
20. *Gardenia* cf. *grieviei* Horne. **Pollen**, Leopold (1969: 1175, pl. 310, figs. 16, 17), Marshall Islands. USGS. A (fide Muller, 1981).
21. *Gardenia pterocalyx* Valetton type. **Pollen**, Anderson & Muller (1975: 307–308, listed only), Borneo. SOCDH. A.
22. †*Gardeniapites taiwanensis* Huang. **Pollen**, Huang (1978: 79, pl. 1, figs. 9, 10), Taiwan. NTU. A (fide Muller, 1981).
23. *Gouatteria* †*tenuinervis*⁴ Engelh. **Leaf**, Engelhardt (1891: 656–657, pl. 5, fig. 6b), Chile, P; Berry (1922: 86, listed only), Chile, P. RN-D (Engelhardt material). P.
24. cf. *Guettarda* L. **Pollen**, Leopold (1969: 1175–1176, pl. 310, figs. 29, 30), Marshall Islands. USGS. A.
25. *Guettarda* †*cookei* Berry. **Leaf**, Berry (1921: 125–126, pl. 21, figs. 5, 6; Tertiary), Dominican Republic. USNM. P. Berry (1923a: 9), Haiti. USNM. P. Berry (1923b: 26), Oaxaca, Mexico (as ?, fragmentary). USNM. P.
26. cf. †*Guettardidites* Khan (see Eocene).
27. *Ixora* cf. *Ixora casei* Hance. **Pollen**, Leopold (1969: 1174, pl. 310, figs. 13–15), Marshall Islands. USGS. A (fide Muller, 1981).
28. *Macrosphyra* (see Oligocene).
29. †*Mitragynaxylon gevini* (see Oligocene).
30. *Mitragyna* Korth. type (see Oligocene).
31. *Morelia* A. Rich. ex DC. (see *Retitriporites boltenhagenii*).
32. †*Retitriporites boltenhagenii* Sal.-Cheb. (1978: 247–248, pl. 6, fig. 2). Salard-Cheboldaeff (1978) compares the fossil to *Morelia senegalensis* A. Rich. ex DC., Cameroon. UPMC. A (as *Morelia* type pollen; Muller, 1981).
33. cf. *Morinda citrifolia* L. **Pollen**, Leopold (1969: 1175, pl. 311, figs. 1, 2, 9, 10), Marshall Islands. USGS. A (fide Muller, 1981).
34. cf. *Mussaenda frondosa* L. **Pollen**, Leopold (1969: 1149, pl. 311, figs. 3, 4), Marshall Islands. USGS. A.
35. *Palaeocoprosmadites*. **Pollen**, Zamalao (2000), Middle Tertiary, Tierra del Fuego, Argentina. MACN. A (as family; see Oligocene).
36. *Posoqueria* Aubl. type. **Pollen**, Graham (1991a: 213, figs. 51–53; 1991b; Fig. 1J), Panama. MO. A.
37. *Posoqueria* †*colombiana* Engelh. **Leaf**, Engelhardt (1895: 40, pl. 7, fig. 8), Colombia. P;

- Berry (1945: 148, listed only), Ecuador. P. Berry (1936: 65–66, pl. 2, fig. 4, Colombia). RN-D (Engelhardt material). USNM (Berry material). P.
38. †*Psilatricolpites coprosmoides* (see Paleocene).
39. †*Psilatriporites corstanjei* Hoorn. **Pollen**, Hoorn (1994a: 102, pl. 4, fig. 35; see also Hoorn, 1994b, c), Colombia, compared to triporate form of *Faramea*. UA. A.
- Randia* (see also †*Triporopollenites bellus*).
40. *Randia* L. **Pollen**, Mildenhall (1980: 222), New Zealand. NZGS. A.
41. cf. *Randia cochinchinensis* (Lour.) Merr. **Pollen**, Leopold (1969: 1176–1177, pl. 310, figs. 31, 32), Marshall Islands. USGS. A (Muller, 1981, but wording may suggest that Leopold compares the fossil specifically to *R. chartacea* F. Muell.).
42. *Randia* †*mohavensis* Axelrod. **Leaf**, Axelrod (1950: 156), California, U.S.A. MPUC. P.
43. †*Retitricolporites crassicostatus* Hammen & Wijmstra. **Pollen**, Hoorn (1994a: 105, pl. 6, fig. 63a, b), Colombia. Compared to Rubiaceae. UA. A.
44. *Rondeletia* L. **Leaf**, Berry (1923b: 26, pl. 7, fig. 3), Oaxaca, Mexico. USNM. P.
45. *Rondeletia* †*goldmani* Berry. **Leaf**, Berry (1918: 42–43, pl. 18, fig. 3), Panama. USNM. P.
46. *Rubia*. **Pollen**, van Campo (1976), Spain. CNRS. A (fide Muller, 1981).
47. Rubiaceae³. **Pollen** types 1, 2, Graham (1989: 63, figs. 45, 46), Panama. MO. A.
48. †*Rubiacites asperuloides*² Weber. **Leaf**, Wessel and Weber (1855: 149, pl. 26, fig. 12), Germany. Repository unknown. P (as family).
49. †*Rubiacites ixoreoides* Berry. **Fruit**, Berry (1918: 43, 44, pl. 18, figs. 9–12). Panama. USNM. P (as family).
50. †*Ruboides lignita* Perkins. **Fruit**, Perkins (1905: 193, pl. 78, figs. 80, 84). Vermont, U.S.A. VGS (specimens not at VGS, location unknown). The Brandon Lignite was later studied by Traverse (1955: 74, 1994; pollen listed by Traverse [1955] as Rubiaceae?, and under Pollen Not Classified, ??Rubiaceae??) and Tiffney (1977 et seq.; fruits, seeds; see also Tiffney & Traverse, 1994; Rubiaceae not listed). P (fruit and pollen as family).
51. *Sabicea* Aubl. **Pollen**, Graham (1987; 1988: 1456, figs. 63, 64; Fig. 1K), Panama. MO. A.
52. *Sabicea* †*asperifolia* Engelm. **Leaf**, Engelhardt (1895: 40–41, pl. 5, fig. 6; pl. 8, fig. 6), Colombia. RN-D. P.
53. *Sabicea*? †*elliptica*⁴ Engelm. (1891: 657, pl. 5, figs. 5, 7). **Leaf**, Chile. P; Berry (1922: 86, listed only), Chile. RN-D (Engelhardt material).
54. *Scyphiphora hydrophyllacea* Gaertn. type pollen. Leopold (1969: 1149, pl. 34, figs. 15, 16), Marshall Islands. USGS. A (fide Muller, 1981).
55. cf. *Timonius* DC. **Pollen**, Leopold (1969: 1176, pl. 310, figs. 21–23), Marshall Islands. USGS. A (fide Muller, 1981).
56. †*Triporopollenites bellus* Stover & Partridge. **Pollen**, Martin (1978: 191, figs. 7r, s), Australia, similar to *Randia chartacea*. UNSWK. A.
57. †*Triporotetradites letouzeyi* Sal.-Cheb. **Pollen**, Salard-Cheboldaeff (1978: 253, pl. 8, fig. 1), Cameroon. Salard-Cheboldaeff (1978) compares the fossil to *Gardenia*. UPMC. A (fide Muller, 1981).
58. †*Triporotetradites* sp. **Pollen**, MacPhail (1999: 205). Early to Middle Miocene, Murray Basin, Australia. MacPhail (1999) compares the fossil to *Gardenia*. ASNU. A.

PLIOCENE

For the Pliocene, 16 fossil taxa representing 14 form and modern genera and six species have been assigned or compared to the Rubiaceae.

1. cf. *Alibertia* A. Rich. ex DC. **Pollen**, Graham (1976: 813, figs. 196, 197, 200), Veracruz, Mexico. MO. A.
2. *Borreria* G. Mey. **Pollen**, Graham (1976: 813, fig. 195), Veracruz, Mexico. MO. A.
3. †*Canthiumidites reticulatus* Khan. **Pollen**, Khan (1976: 766, fig. 29), Papua New Guinea. Khan (1976) compares the fossil to *Canthium obovatum* Klotzsch ex Eckl. & Zeyh. RRNA. A (as *Canthium* type fide Muller, 1981).
4. *Cephalanthus occidentalis* L. **Leaf**, Hannibal (1911: 335, 339), California, U.S.A. SUPA (possibly consolidated with collections at the Museum, UC-Berkeley). P.

5. *Faramea* Aubl. **Pollen** (triporate form), Graham (1976: 813, figs. 179, 180; Fig. 1D), Veracruz, Mexico. MO. A.
6. cf. *Galium* L. **Pollen**, Menke (1976: 65–66, text-fig. 4b, pl. 36, figs. 9–11), Germany. Geologisches Landesamt, Schleswig-Holstein. P (fide Muller, 1981, “Menke (1976) has tentatively identified *Galium* pollen from the Pliocene of northwest Germany.”).
7. cf. †*Guettardidites wirensis* Khan (see Eocene).
8. *Hoffmannia* †*boliviana* Berry. **Leaf**, Berry (1939b: 63–64, pl. 4, fig. 11), Bolivia. USNM. P.
- Laugeria* L. (see *Terebraria* Kuntze).
9. *Nertera* Banks & Sol. ex Gaertn. **Pollen**, Mildenhall (1980: 215, 228); listed only; lower Pliocene? New Zealand. See also Mildenhall and Crosbie (1979).
10. †*Psilatricolpites coprosmoides* (see Paleocene).
11. *Psychotria* L. **Pollen**, Wijninga (1996: 152, pl. 4, fig. 40), Colombia. UA. A.
12. Rubiaceae. **Pollen**, Wijninga (1996: 152, pl. 4, fig. 39), Colombia. UA. A.
13. Rubiaceae. **Pollen**, stephanocolpate, Graham (1976, figs. 237, 238), Veracruz, Mexico. MO. A.
14. †*Rubiacites nummularioides* Berry. **Leaf**, Berry (1917: 161, pl. 18, fig. 15; Singewald & Berry, 1922: 42, 111–112, pl. 7, fig. 7), Bolivia. USNM. P (as family).
15. *Sabicea* Aubl. **Pollen**, Graham and Dilcher (1998: 1430, fig. 18), Costa Rica. MO. A.
16. *Terebraria* Kuntze in Post & Kuntze. **Pollen**, Graham (1976: 813, figs. 187, 188), Veracruz, Mexico. MO. A (as *Terebraria* type; now *Laugeria* L.).

TERTIARY (UNDIFFERENTIATED; MOST NEOGENE,
PROBABLY MIOCENE)

For the Tertiary undifferentiated, 14 fossil taxa representing 11 form and modern genera and 14 species have been assigned or compared to the Rubiaceae.

- 1–4. †*Coprosmaephyllum angustifolium* Deane. **Leaf**, Deane (1904: 213, pl. 20, figs. 4–6); *Coprosmaephyllum attenuatum* Deane. **Leaf**, Deane (1904: 213, pl. 20, figs. 9, 10);

Coprosmaephyllum minus Deane. **Leaf**, Deane (1904: 213, pl. 20, figs. 7, 8); *Coprosmaephyllum ovatum* Deane. **Leaf**, Deane (1904: 212, pl. 20, figs. 1–3), Australia. Deane (1904) compares the fossils to the extant *Coprosma*. GSV. A.

5. *Coussarea* †*membranacea* Engelm. **Leaf**, Engelhardt (1891: 656, pl. 5, fig. 2). Chile. RN-D. P.
6. *Gouatteria* †*tenuinervis* Engelm. **Leaf**, Engelhardt (1891: 656–657, pl. 5, fig. 6b). Chile. RN-D. P.
7. *Guettarda* †*cookei* Berry. **Leaf**, Berry (1921: 125–126, pl. 21, figs. 5, 6), Dominican Republic. USNM. P.
8. *Hoffmannia* †*protogaea* Engelm. **Leaf**, Engelhardt (1891: 657, pl. 5, fig. 1), Chile. RN-D. P.
9. *Psychotria* †*grandifolia* Engelm. **Leaf**, Engelhardt (1891: 656, pl. 11, fig. 4), Chile. RN-D. P.
10. †*Psychotriphyllum attenuatum* Deane. **Leaf**, Deane (1900: 60, pl. 15, fig. 2), Australia. Deane (1900) compares the fossil to *Psychotria*. GSV. A.
11. *Rondeletia* †*goldmani* Berry. **Leaf**, Berry (1937: 72, 79), Trinidad. USNM. P.
12. †*Rubiaceaecarpum multicarpellare* Menzel. **Fruit**, Menzel (1913: 10, pl. 1, figs. 20–24), Germany. Dresden. P (as family).
13. †*Rubiiphyllites linearis* Hector. **Leaf**, Hector (1880: 49; nom. nud. fide Andrews, 1970), New Zealand. Repository unknown. NA.
14. *Sabicea*? †*elliptica* Engelm. **Leaf**, Engelhardt (1891: 657, pl. 5, figs. 5, 7), Chile. RN-D. P.

QUATERNARY

A number of Rubiaceae have been reported for the Quaternary, mostly Late Glacial and Holocene, representing taxa currently growing in the region of the fossil locality, in the modern (post 1975) literature, and used primarily for paleoenvironmental reconstructions. All are plausible and designated “A” (Accepted). Among examples of these records included here are 13 genera and 10 species:

1. *Borreria* G. Mey. (Cuba: Moncana Ferrera et al., 1990–1991; Belize: Hansen, 1990; Panama: Bartlett & Barghoorn, 1973; Galápagos Islands: Colinvaux & Schofield, 1976; Colombia: Hooghiemstra, 1984; Brazil: Ledru et al., 2001; de

- Oliveira et al., 1999; Behling, 1997b; Bolivia: Paduano et al., 2003).
2. *Borreria anthospermoides* DC. (Colombia: Hooghiemstra, 1984).
 3. *Borreria laevis* (Lam.) Griseb. (Colombia: Hooghiemstra, 1984).
 4. *Borreria latifolia* (Aubl.) K. Schum. (Brazil: Behling, 1997b).
 5. *Canthium* Lam. (Borneo: Anderson & Muller, 1975).
 6. *Cephalanthus* L. (Louisiana, U.S.A.: Delcourt & Delcourt, 1977).
 7. *Cephalanthus occidentalis* L. (Tennessee, U.S.A.: Berry, 1924).
 8. *Faramea* Aubl. (Panama: Bartlett & Barghoorn, 1973).
 9. *Faramea occidentalis* (L.) A. Rich. (Cuba: Moncada Ferrera et al., 1990–1991).
 10. *Galium* L. (California, U.S.A.: Potbury, 1932; Washington, D.C., U.S.A.: Berry, 1924; Baja California, Mexico: Lozano-Garcia et al., 2002; Chile: Latorre et al., 2003; China, Late Pliocene to Quaternary: G. Liu, pers. comm., 2002; included in Mildenhall, 1980: 215, Late Quaternary, New Zealand).
 11. *Galium californicum* Hook. & Arn. (California, U.S.A.: Mason, 1934).
 12. *Galium palustre* L. (Germany: D. Mai, pers. comm., 2002; Mania & Mai, 1969).
 13. *Galium stellatum* Kellogg (Chihuahuan Desert, Mexico/U.S.A.: van Devender, 1990).
 14. *Guettarda calyptrata* A. Rich. (Cuba: Moncada Ferrera et al., 1990–1991).
 15. *Jackia* Wall. in Roxb. (Borneo: Anderson & Muller, 1975).
 16. *Machaonia* Bonpl. (Venezuela: Salgado-Labouriau, 1980).
 17. *Psychotria* L. (Brazil: Behling, 1997b).
 18. *Psychotria* cf. *alba* Ruiz & Pav. (Brazil: Behling, 1997b).
 19. *Randia* L. (Panama: Bartlett & Barghoorn, 1973).
 20. *Relbunium* (Endl.) Hook. f. (Brazil: Behling, 1997b; Colombia: Hooghiemstra, 1984).
 21. Rubiaceae (Argentina: Heusser, 1995; Mancini, 1998; Prieto, 2000; Quattrocchio & Borromei, 1998; Brazil: van der Hammen & Absy, 1994; Behling, 1997a; de Oliveira et al., 1999; Chile: Paduano et al., 2003; Heusser et al., 1999; Colombia: Hooghiemstra, 1984; Costa Rica: Hooghiemstra et al., 1992; Islebe & Hooghiemstra, 1997; Kesel, 1983; Guatemala: Islebe et al., 1996; Mexico: Brown & Jacobs, 1988; Lozano-Garcia et al., 2002; Panama: Bartlett & Barghoorn, 1973).
 22. *Timonius* DC. (Borneo: Anderson & Muller, 1975).
 23. *Warszewiczia* Klotzsch (Colombia: Hooghiemstra, 1984).

DISCUSSION

Based on the above synopsis, the accepted and pending records are summarized in Table 1, and the currently accepted records are arranged according to subfamilies, age, locality, and present distribution of the closest modern analogs in Table 2. From this summary, some generalizations emerge, as well as places where additional information would be especially useful. Regarding the origin of the family, the presently accepted fossils are too young to provide a clear indication. The oldest are cf. *Emmenopterys* from the 49–48 Ma Middle Eocene Republic flora of Washington, U.S.A. (Wehr & Manchester, 1996; subfamily Ixoroideae), and *E. dilcheri* from the 44 Ma Middle Eocene Clarno flora of Oregon, U.S.A. (Manchester, 1994). The genus is presently found in the People's Republic of China, where other genera similar to western American Tertiary plant fossils occur (e.g., *Metasequoia* Hu & W. C. Cheng, *Ailanthus* Desf., *Cercidium* Tul. complex, *Engelhardia* Lesch. ex Blume, *Platycarya* Siebold & Zucc., *Pterocarya* Kunth; Graham, 1999: 200–217). The next oldest fossils are from the Late Eocene and include *Canthium* (Australia, MacPhail, 1999; present distribution Old World tropics; subfamily Ixoroideae), *Faramea* (Panama, Graham, 1985; present distribution tropical America; subfamily Rubioideae), and *Guettarda* (Australia, MacPhail, 1999; present distribution New Caledonia and tropical America), in addition to the alternate-leaved †*Paleorubiaceophyllum* from the Middle Eocene of the southeastern U.S.A. Thus, in the Eocene, the family is represented by four or five genera, from all three subfamilies as presently circumscribed, in North America, Central

Table 1. Genera of accepted (A) and pending (P) Rubiaceae reported in the fossil record arranged according to subfamilies and tribes. The subfamilial classification follows that used in Dessein et al. (2005; see also Jalaluddin et al., 2008; Kahan et al., 2008; Martínez-Cabrera et al., 2008; Smedmark et al., 2008).

Taxon	Age	Locality ¹	Status
Subfamily Rubioideae			
Coussareeae			
<i>Coussarea</i>	Tertiary	Chile	P
	Eocene	Argentina	P
<i>Faramea</i>	Late Eocene	Panama	A
	Middle Oligocene	Puerto Rico	A
	Early Miocene	Panama	A
	Eocene	Argentina	P
	Pliocene	Panama	A
<i>Faramea</i> (as <i>Psilatropites corstanjei</i>)	Miocene	Colombia	A
	Middle Pliocene	Veracruz, Mexico	A
Psychotrieae			
<i>Psychotria</i>	Eocene	Peru	P
	Eocene	KY/TN	P
	Eocene	OR	P
	Pliocene	Colombia	A
	Tertiary	Chile	P
<i>Psychotria</i> (as <i>Psychotriphyllum attenuatum</i>)	Tertiary	Australia	A
Morindeae			
<i>Morinda</i>	Miocene	Marshall Islands	A
Spermacoceae			
<i>Borreria</i>	Pliocene	Veracruz, Mexico	A
	Miocene	Senegal	A
Anthospermeae			
<i>Coprosma</i>	Eocene	Argentina	P
<i>Coprosma</i> (as <i>Coprosmaephyllum angustifolium</i> et al.)	Tertiary	Australia	A
<i>Coprosma</i> (as <i>Psilatricolpites coprosmoides</i>)	Paleocene	Chile	P
<i>Coprosma</i> – <i>Opercularia</i> (as <i>Palaeocoprosmadites zelandiae</i>)	Oligocene to Pleistocene	New Zealand	A
<i>Coprosma</i> type	Miocene	Marshall Islands	P
Rubieae			
<i>Galium</i>	Paleocene	Greenland	P
<i>Galium</i>	Miocene	AK	A
cf. <i>Galium</i>	Pliocene	Germany	P
<i>Rubia</i>	Miocene	Spain	A
Subfamily Ixoroideae			
Condamineae			
<i>Condaminea</i>	Miocene	Colombia, Peru	P
<i>Elaeagia</i> (as <i>Elaeagnites campanulatus</i>)	Miocene	Spitsbergen	P
<i>Emmenopterys</i>	Middle Eocene	WA, OR	A
<i>Pinckneya</i>	Oligocene	OR	A
Sabiceae			
<i>Sabicea</i>	Miocene	Panama	A
	Pliocene	Costa Rica	A
(as <i>Sabicea? elliptica</i>)	Tertiary	Chile	P
(as <i>Sabicea asperifolia</i>)	Miocene	Colombia	P
Ixoreae			
<i>Ixora</i>	Miocene	Marshall Islands	A
(as <i>Ixorophyllum anceps</i>)	Eocene	Borneo	P
<i>Scyphiphora</i>	Miocene	Marshall Islands	A
Vanguerieae			
<i>Canthium</i> (as <i>Rubipollis oblatus</i>)	Late Eocene to Early Pliocene	Australia	A
	Miocene	Croatia	P
<i>Canthium</i> (as <i>Canthiumidites reticulatus</i>)	Pliocene	Papua New Guinea	A

Table 1. Continued.

Taxon	Age	Locality ¹	Status
Gardenieae			
cf. <i>Alibertia</i>	Pliocene	Veracruz, Mexico	A
<i>Gardenia</i> type (as <i>Tripоротetradites nachterstedtensis</i>)	Late Eocene	Germany	P
<i>Gardenia</i>	Miocene	Borneo	A
	Miocene	Marshall Islands	A
(as <i>Gardeniapites taiwanensis</i>)	Miocene	Taiwan	A
(as <i>Tripоротetradites letouzeyi</i>)	Miocene	Cameroon	A
(as <i>Tripоротetradites</i> sp.)	Early to Middle Miocene	Australia	A
<i>Macrosphyra</i> (as <i>Tripоротetradites hoekeni</i>)	Oligocene, Miocene	Cameroon	A
<i>Morelia</i> (as <i>Retitriporites boltenhagenii</i>)	Miocene	Cameroon	A
Subfamily Cinchonoideae			
Cinchoneae			
<i>Cinchona</i> (as <i>Cinchonidium ovale</i>)	Paleocene	ND	P
<i>Cinchona</i> (as <i>Cinchonidium copeanum</i>)	Oligocene	NV	P
<i>Cinchona</i> (as <i>Cinchonidium racemosum</i>)	Miocene	Croatia	P
Portlandia–Exostema–Catesbaeae–Chiococceae (PECC) clade			
<i>Chiococca</i>	Miocene	CA	A
<i>Exostema</i>	Middle Eocene	TN/KY	P
(as <i>Exostema precaribaeum</i>)	Miocene	Cuba	P
<i>Remijia</i>	Eocene	Argentina	P
Naucleaeae			
<i>Cephalanthus</i>	Eocene	Argentina	P
	Pliocene	CA	P
<i>Mitragyna</i> (as <i>Retitricolporites annulatus</i>)	Oligocene	Cameroon	A
<i>Mitragyna</i> (as <i>Mitragynaxylon</i>)	Oligocene, Miocene	Algeria	P
Hilleae–Hamelieae			
<i>Cosmibuena</i>	Miocene	Panama	A
<i>Hoffmannia</i>	Eocene, Tertiary	Argentina, Chile	P
	Pliocene	Bolivia	P
Rondeletieae			
<i>Rondeletia</i>	Miocene	Oaxaca, Mexico	P
	Miocene	Panama	P
	Eocene	Argentina	P
	Tertiary	Trinidad	P
Guettardeae			
<i>Guettarda</i>	Eocene	MS/TN	P
(as cf. <i>Guettardidites</i>)	Oligocene	Puerto Rico	P
	Eocene to Pliocene	Australia	A
	Oligocene	Puerto Rico	P
cf. <i>Guettarda</i>	Miocene	Marshall Islands	A
	Tertiary	Dominican Republic	P
	Miocene	Haiti	P
	Miocene	Oaxaca, Mexico	P
<i>Terebraria</i> (<i>Laugeria</i> ; as <i>Terebraria</i> type)	Pliocene	Veracruz, Mexico	P
cf. <i>Randia</i>	Miocene	Marshall Islands	A
<i>Randia</i>	Miocene	New Zealand	A
<i>Randia</i> (as <i>Canthiumidites bellus</i>)	Early to Middle Miocene	Australia	A
<i>Randia</i> (as <i>Tripорopollenites bellus</i>)	Miocene	Australia	A
<i>Randia</i>	Miocene	CA	P
<i>Randia</i>	Miocene	Marshall Islands	A
cf. <i>Timonius</i>	Miocene	Marshall Islands	A
Uncertain position/incertae sedis			
<i>Bothriospora</i>	Miocene	Colombia	P
<i>Endlicheria</i> (Lauraceae?)	Miocene	Colombia, Ecuador	P
<i>Gouatteria</i>	Tertiary	Chile	P
cf. <i>Mussaenda</i>	Miocene	Marshall Islands	A

Table 1. Continued.

Taxon	Age	Locality ¹	Status
<i>Posoqueria</i> type	Miocene	Panama	A
		Colombia	P
		Ecuador	P
<i>Terebraria</i>	Pliocene	Veracruz, Mexico	A
<i>Uragoga tertiaria</i> (subfam.?)	Eocene	Peru	P
Rubiaceae (family only)			
<i>Chomelia</i> type	Miocene	Panama	A
Rubiaceae	Eocene	Panama	A
	Miocene	Panama	A
	Pliocene	Colombia	A
	Pliocene	Veracruz, Mexico	A
(as <i>Retitricolporites crassicostatus</i>)	Miocene	Colombia	P
(as <i>Rubiacites asperuloides</i>)	Miocene	Germany	P
(as <i>Rubiacites chomeliifolia</i>)	Eocene	Argentina	P
(as <i>Rubiacites ixoreoides</i>)	Miocene	Panama	P
(as <i>Rubiacites nummularioides</i>)	Pliocene	Bolivia	P
(as <i>Rubiacites? pellicieraformis</i>)	Eocene	TN	P
(as <i>Rubiacites sphericus</i>)	Eocene	TN/KY	P
(as <i>Rubiacites wilcoxensis</i>)	Eocene	TN/KY	P
(as <i>Rubiaceocarpum markgrafi</i>)	Eocene	Egypt	P
(as <i>Rubiaceacarpum multicarpellare</i>)	Tertiary	Germany	P
(as <i>Rubioxylon naucleoides</i>)	Oligocene	Austria	P
(as <i>Ruboides lignita</i>)	Miocene	VT	P
Subfamily assignment uncertain			
<i>Paleorubiaceophyllum eocenicum</i>	Eocene	TN/KY	A

¹ Abbreviations for states (U.S.A.) are: AK, Alaska; CA, California; KY, Kentucky; MS, Mississippi; ND, North Dakota; NV, Nevada; OR, Oregon; TN, Tennessee; VT, Vermont; WA, Washington.

America, and Australia. This representation and distribution indicate an earlier Late Cretaceous or Paleocene origin and emphasize the need to: (1) further investigate the pending Paleocene material, and (2) devote special attention to Cretaceous megafossil deposits, such as the Early Cretaceous (Aptian) Anfiteatro de Ticó flora of Argentina, the Aptian–Albian Crato flora of Brazil, the late Middle Cretaceous (Turonian) flora of New Jersey, the Late Cretaceous (Senonian) flora of Sweden, and elsewhere for plants of rubiaceous-complex affinities.

After the Cretaceous and Paleocene, the numbers of accepted genera (form generic and modern names, including cf. identifications) in subsequent epochs are Eocene: four or five, Oligocene: six, Miocene: 20, and Pliocene: seven. Even allowing for some duplication of form-generic and modern names (†*Palaeocoprosma*, †*Psilatricolpites*–*Coprosma*; *Triporetetradites letouzeyi*–*Gardenia*; *Guettardidites*–*Guettarda*), and the different number and size of the floras studied for the various intervals, the figures suggest the Miocene (23.8–5.3 Ma) as a time of major diversification of the Rubiaceae.

The radiation of the family based on accepted records parallels the pattern of diversification. In the Eocene, fossils of Rubiaceae are known from

three regions: North America north of Mexico (Washington, Oregon, U.S.A., *Emmenopterys*; possibly the southeastern U.S.A., *Paleorubiaceophyllum*); Mexico–Central America–Caribbean region (Panama, *Faramea*); and the Southeast Pacific–Asia region (Australia, *Canthium*, *Guettarda*). In the Oligocene, they are found in four regions: North America north of Mexico (Oregon, *Pinckneya*); Mexico–Central America–Caribbean region (the Antilles, *Faramea*); the Southeast Pacific–Asia region (Australia, *Guettarda*; New Zealand, *Coprosma*, *Coprosma*–*Opercularia*); and Africa (Cameroon, *Macrosphyra*, *Mitragyna*). By the Miocene, accepted reports of Rubiaceae include six regions (with nine subregions): North America (California, U.S.A., *Chiococca*; Alaska, U.S.A., *Galium*), Mexico–Central America–Caribbean region (Panama, *Chomelia*, *Cosmibuena*, *Faramea*, *Posoqueria* type, *Sabicea*), South America (Colombia, *Faramea*), Southeast Pacific–Asia region (Australia, *Gardenia*, *Guettarda*, *Randia*; New Zealand, *Randia*; Borneo, *Gardenia*; Marshall Islands, *Gardenia*, *Guettarda*, *Ixora* L., *Morinda*, cf. *Mussaenda*, cf. *Randia*, cf. *Timonius*; Taiwan, *Gardenia*), Africa (Cameroon, *Macrosphyra*, *Mitragyna*, *Morelia*, *Gardenia*; Senegal, *Borreria*), and Europe (Spain, *Rubia*).

Table 2. Summary of the "A" (accepted) records of the Rubiaceae.

Taxon	Age	Fossil occurrence ¹	Modern distribution ¹
Subfamily Rubioideae ²			
<i>Faramea</i>	Eocene	Panama	tropical America
	Middle Oligocene	Puerto Rico	
	Early Miocene	Panama	
	Miocene	Colombia	
	Pliocene	Veracruz, Mexico	
<i>Coprosma</i>	Oligocene to Pleistocene	New Zealand	Southeast Asia, Chile (Juan Fernandez Islands)
<i>Morinda</i>	Miocene	Marshall Islands	tropical
<i>Borreria</i>	Miocene	Senegal	warm regions of the world
	Pliocene	Veracruz, Mexico	
<i>Galium</i>	Miocene	AK	nearly cosmopolitan
<i>Rubia</i>	Miocene	Spain	warm regions of the world
<i>Psychotria</i>	Pliocene	Colombia	warm regions of the world
	Tertiary	Australia	
Subfamily Ixoroideae ³			
<i>Emmenopterys</i>	Middle Eocene	WA/OR	People's Republic of China, Burma, Thailand
<i>Canthium</i>	Late Eocene to Early Pliocene	Australia	Old World tropics
	Pliocene	Papua/New Guinea	
	Pliocene	Papua/New Guinea	
<i>Pinckneya</i>	Oligocene	OR	Southeastern U.S.A.
<i>Macrosphyra</i>	Oligocene to Miocene	Cameroon	tropical Africa
<i>Gardenia</i>	Early to Middle Miocene	Australia	Old World tropics
	Miocene	Borneo	
	Miocene	Marshall Islands	
	Miocene	Taiwan	
	Miocene	Cameroon	
	Miocene	Cameroon	
<i>Ixora</i>	Miocene	Marshall Islands	New and Old World tropics
<i>cf. Posoqueria</i>	Miocene	Panama	New World tropics
<i>Morelia</i>	Miocene	Cameroon	tropical Africa
<i>Mussaenda</i>	Miocene	Marshall Islands	Old World tropics
<i>Sabicea</i>	Miocene	Panama	tropical America, Africa, Madagascar
	Pliocene	Costa Rica	
<i>Scyphiphora</i>	Miocene	Marshall Islands	Indomalaysian coasts, India, Sri Lanka, Australia
<i>Alibertia</i>	Pliocene	Veracruz, Mexico	tropical America, West Indies
Subfamily Cinchonoideae ⁴			
<i>Chiococca</i>	Miocene	CA	FL; West Indies, tropical America
<i>Guettarda</i>	Eocene to Pliocene	Australia	New Caledonia, tropical America
	Miocene	Marshall Islands	
<i>Randia</i>	Miocene	Australia	New and Old World tropics (present-day definition, tropical America)
	Miocene	New Zealand	
	Miocene	Marshall Islands	
<i>Mitragyna</i>	Oligocene	Cameroon	tropical Africa, Asia
<i>Cosmibuena</i>	Miocene	Panama	tropical southern Mexico, Central and South America
<i>cf. Timonius</i>	Miocene	Marshall Islands	Southeast Asia, Pacific islands

¹ Abbreviations for states (U.S.A.) are: AK, Alaska; CA, California; OR, Oregon; WA, Washington.

² Eight genera, seven accepted; oldest: Middle(?) to Late Eocene (*Faramea*), Panama.

³ Twelve genera, 12 accepted; oldest: Middle Eocene (*Emmenopterys*), WA/OR; Late Eocene to Early Pliocene (*Canthium*), Australia.

⁴ Thirteen genera, six accepted; 32; oldest: Late Eocene to Pliocene (*Guettarda*), Australia.

The earliest accepted appearance of modern Rubiaceae in the Eocene and its extensive diversification and radiation in the Miocene involve several factors. One is the length of the different epochs within the Tertiary Period: Paleocene (~65–54.8 Ma; 10.2 Ma duration), Oligocene (33.7–23.8 Ma; 9.9 Ma), and Pliocene (5.3–1.8 Ma; 3.5 Ma), compared to the Eocene (54.8–33.7 Ma; 21.1 Ma) and the Miocene (23.8–5.3 Ma; 18.5 Ma). However, during these longer epochs, fundamental changes took place in the climate and landscape at more specific times (Graham, 1999, 2008). In the Eocene, it was a significant change from the Paleocene–Eocene Thermal Maximum (PETM) or the Early Eocene Climatic Optimum (EECO), during which time temperatures were as warm or warmer than in all of the Phanerozoic (last 500 Ma), to cooler temperatures in the Middle and Late Eocene, representing the transition from hothouse to eventual icehouse conditions. This interval near the Middle to Late Eocene boundary also corresponds to the time when an increasing number of plant fossils can be referred to modern genera; viz., a principal period in the modernization of the Earth's vegetation.

The time spanning the Miocene involved both climatic and physical changes in the landscape. At the beginning of the Miocene (23.8 Ma), Arctic glaciers were present but not extensive, whereas by the end of the epoch (5.3 Ma) and in the Mio-Pliocene, there were both continental glaciers and sea ice that supplemented Antarctic glaciers in cooling the waters of the ocean basins. The effect, evident globally by the beginning of the Middle Miocene (~15 Ma), was another drop in temperature and a marked increase in seasonality. The vegetation responded with expanding versions of seasonally dry forests, caatingas, cerrado, steppe, savanna, grasslands, and near-deserts that would form communities modern in range and composition during the increasingly cold, dry intervals of the Pliocene and Quaternary.

Climate changes in the Miocene were paralleled by pronounced alterations in the landscape. For example, the Transvolcanic Belt of Mexico and the Central Andes Mountains of South America (Gregory-Wodzicki, 2000; Gregory-Wodzicki et al., 1998; Graham et al., 2001) attained most of their elevation, as did the Himalayas, during the 18 Ma interval of the Miocene.

The evolution of character traits is difficult to reconstruct from the fossil record presently available. However, the appearance of certain features can be documented by specific points in time. The typical leaf arrangement in the Rubiaceae is opposite, with alternate leaves found in a few, more advanced genera (e.g., *Didymochlamys*, *Sabicea*, *Theligonum*). However, if †*Paleorubiacephyllum* is correctly assigned to

the family, as seems likely, this apomorphic character was present by the Middle Eocene (~45 Ma).

Pollen polymorphism is often associated with heterostyly, usually expressed by differences in pollen size, exine thickness, or occasionally pollen sculpture patterns in the different anther lengths (e.g., *Rudgea jasminoides* (Cham.) Müll. Arg.; scabrate in pin flowers, echinate in thrum flowers; Baker, 1956). In *Faramea*, however, distinctly diporate, triporate, and occasional tetraporate pollen occurs on the same reference slides of modern pollen. In some species, almost all the grains are triporate (e.g., *F. talamancarum* Standl., Panama, Kirkbride et al. 496, MO) and in others they are mostly diporate (*F. vaginata* Griseb., Cuba, Webster 3837, MO), while occasionally tetraporate pollen is abundant (*F. scalaris* Standl., Panama, Davidson 436, MO). If this pollen polymorphism, as opposed to random pollen variability or sterility in *Faramea*, is associated with heterostyly, then the feature, or its early development, was already present by the Late Eocene as shown by the diporate form in the Gatuncillo Formation of Panama. The presence of alternate leaves and pollen dimorphism in the Eocene, together with the diversity and distribution of Rubiaceae in that epoch, all suggest an earlier origin for the family.

CONCLUSION

The history of the Rubiaceae is based on assessments from the synopsis of all known reports. Tables 1 (accepted and pending reports) and 2 (accepted reports only) provide a more realistic statement of the current paleobotanical status of the family than implied by the older literature, and reveal stages in the evolution of the group after its origin. The oldest verified occurrences are in the Eocene, yet the number of likely taxa and their distribution, and the possible presence of apomorphic features such as alternate leaves and pollen polymorphism, suggest a pre-Eocene origin, probably in the Late Cretaceous or Early Paleocene. The climatic changes in the Miocene favoring the generation of novel genotypes and phenotypes, and pronounced landscape evolution providing an increased diversity of habitats, are compatible with the fossil record and further suggest the Miocene as a time of significant diversification and radiation of the family.

Literature Cited

- Anderson, J. A. R. & J. Muller. 1975. Palynological study of a Holocene peat and a Miocene coal deposit from NW Borneo. *Rev. Palaeobot. Palynol.* 19: 291–351.
Andrews, H. N. Jr. 1970. Index of Generic Names of Fossil Plants, 1820–1965. *U.S. Geol. Surv. Bull.* 1300: 1–354.

- Axelrod, D. I. 1940. The Mint Canyon flora of southern California: A preliminary statement. *Amer. J. Sci.* 238: 577–585.
- . 1950. The Anaverde flora of southern California. *Carnegie Inst. Wash. Publ.* 590: 119–158.
- . 1979. Age and origin of Sonoran Desert vegetation. *Occas. Pap. Calif. Acad. Sci.* 132: 1–74.
- Baker, H. G. 1956. Pollen dimorphism in the Rubiaceae. *Evolution* 10: 23–31.
- Barreda, V. D. 1997. Palinoestratigrafía de la Formación San Julián en el área de Playa La Mina (Provincia de Santa Cruz), Oligoceno de la cuenca austral. *Ameghiniana* 34: 283–294.
- Bartlett, A. S. & E. S. Barghoorn. 1973. Phytogeographic history of the Isthmus of Panama during the past 12,000 years (a history of vegetation, climate, and sea-level change). Pp. 203–229 in A. Graham (editor), *Vegetation and Vegetational History of Northern Latin America*. Elsevier Science Publishers, Amsterdam.
- Behling, H. 1997a. Late Quaternary vegetation, climate, and fire history of the *Araucaria* forest and campos region from Serra Campos Gerais, Paraná State (south Brazil). *Rev. Palaeobot. Palynol.* 97: 109–121.
- . 1997b. Late Quaternary vegetation, climate, and fire history from the tropical mountain region of Morro de Itapeva, SE Brazil. *Palaeogeogr. Palaeoclimatol. Palaeoecol.* 129: 407–422.
- Berry, E. W. 1916. The lower Eocene floras of southeastern North America. *U.S. Geol. Surv. Prof. Paper* 91: 1–481.
- . 1917. Fossil plants from Bolivia and their bearing on the age of uplift of the Eastern Andes. *Proc. U. S. Natl. Mus.* 54: 103–164.
- . 1918. The fossil higher plants from the Canal Zone. Pp. 15–44 in *Contributions to the Geology and Paleontology of the Canal Zone, Panama, and Geologically Related Areas in Central America and the West Indies*. *Bull. U.S. Natl. Mus.*, Vol. 103.
- . 1919. Miocene fossil plants from northern Peru. *Proc. U. S. Natl. Mus.* 55: 279–294.
- . 1921. Tertiary fossil plants from the Dominican Republic. *Proc. U. S. Natl. Mus.* 59: 117–127.
- . 1922. The flora of the Concepción-Arauco coal measures of Chile. Pp. 73–144 in E. B. Mathews (editor), *Contributions to the Paleobotany of Peru, Bolivia, and Chile*, No. 4. The Johns Hopkins University Studies in Geology, Baltimore.
- . 1923a. Tertiary fossil plants from the Republic of Haiti. *Proc. U. S. Natl. Mus.* 62: 1–10.
- . 1923b. Miocene plants from southern Mexico. *Proc. U. S. Natl. Mus.* 62: 1–27.
- . 1924. The fossil swamp deposit at the Walker Hotel site, Washington, D.C.: Organic remains other than diatoms. *J. Wash. Acad. Sci.* 14: 12–25.
- . 1925. A Miocene flora from Patagonia. *Johns Hopkins Univ. Stud. Geol.* 6: 183–251.
- . 1929a. The fossil flora of the Loja Basin in southern Ecuador. Pp. 79–136 in *Contributions to the Paleontology of Colombia, Ecuador, and Peru*, No. 10. The Johns Hopkins University Studies in Geology, Baltimore.
- . 1929b. Tertiary fruits and seeds from northwestern Peru. Pp. 137–182 in *Contributions to the Paleontology of Colombia, Ecuador, and Peru*, No. 10. The Johns Hopkins University Studies in Geology, Baltimore.
- . 1930. Revision of the lower Eocene Wilcox Flora of the southeastern United States, with descriptions of new species chiefly from Tennessee and Kentucky. *U.S. Geol. Surv. Prof. Paper* 156: 1–196.
- . 1936. Miocene plants from Colombia, South America. *Bull. Torrey Bot. Club* 63: 53–66.
- . 1937. A late Tertiary flora from Trinidad, B.W. I. *Johns Hopkins Univ. Stud. Geol.* 12: 69–79.
- . 1938. Tertiary flora from the Río Pichileufu, Argentina. *Geol. Soc. Amer. Sp. Papers* 12: 1–149.
- . 1939a. A Miocene flora from the Gorge of the Yumurí River, Matanzas, Cuba. *Johns Hopkins Univ. Stud. Geol.* 13: 95–135.
- . 1939b. The fossil flora of Potosí, Bolivia. *Johns Hopkins Univ. Stud. Geol.* 13: 9–67.
- . 1941. Additions to the Wilcox Flora from Kentucky and Texas. *U.S. Geol. Surv. Prof. Paper* 193-E: 83–99.
- . 1945. Fossil floras from southern Ecuador. *Johns Hopkins Univ. Stud. Geol.* 14: 93–150.
- Blazer, A. M. 1975. Index of generic names of fossil plants, 1966–1973. *U.S. Geol. Surv. Bull.* 1396: 1–54.
- Brown, R. B. & B. F. Jacobs. 1988. Análisis e interpretación del polen de dos lagos del occidente de México. *Palynolog. & Palaeobot.* 1: 45–59.
- Chaney, R. W. & E. I. Sanborn. 1933. The Goshen flora of west central Oregon. *Carnegie Inst. Washington Publ.* 439: 1–103.
- Colinvaux, P. A. & E. K. Schofield. 1976. Historical ecology in the Galápagos Islands. I. Holocene pollen record from El Junco Lake, Isla San Cristobal. *J. Ecol.* 64: 989–1012.
- Couper, R. A. 1953. Upper Mesozoic and Cainozoic spores and pollen grains from New Zealand. *New Zealand Geol. Surv. Paleontol. Bull.* 22: 1–77.
- . 1960. New Zealand Mesozoic and Cainozoic plant microfossils. *New Zealand Geol. Surv. Paleontol. Bull.* 32: 1–87.
- Deane, H. 1900. Note on fossil leaves from the Tertiary deposits of Wingello and Bungonia. *Rec. Geol. Surv. New South Wales* 7, pt. 1: 59–65.
- . 1904. Further notes on the Cainozoic flora of Sentinel Rock, Otway Coast. Department of Mines, Records of the Geological Survey of Victoria 1, pt. 3: 212–217.
- Delcourt, P. A. & H. R. Delcourt. 1977. The Tunica Hills, Louisiana-Mississippi: Late glacial locality for spruce and deciduous forest species. *Quatern. Res.* 7: 218–237.
- de Oliveira, P. E., A. M. Franca Barreto & K. Suguio. 1999. Late Pleistocene/Holocene climatic and vegetational history of the Brazilian caatinga: The fossil dunes of the middle São Francisco River. *Palaeogeogr. Palaeoclimatol. Palaeoecol.* 152: 319–337.
- Dessein, S., H. Ochoterena, P. De Block, F. Lens, E. Robbrecht, P. Schols, E. Smets, S. Vickier & S. Huysmans. 2005. Palynological characters and their phylogenetic signal in Rubiaceae. *Bot. Rev.* 71: 354–414.
- Dilcher, D. L. & T. A. Lott. 2005. A middle Eocene fossil plant assemblage (Powers Clay Pit) from western Tennessee. *Florida Mus. Nat. Hist. Bull.* 45: 1–43.
- Doubinger, J. & P. Chotin. 1975. Étude palynologique de lignites Tertiaires du Basin d'Arauco-Concepción (Chili). *Revista Esp. Micropaleontol.* 7: 549–565.
- Engelhardt, H. 1891. Ueber Tertiärpflanzen von Chile. *Abh. Senckenberg. Naturf. Ges.* 16: 629–692.
- . 1895. Über neue Tertiärpflanzen Süd-Amerikas. *Abh. Senckenberg. Naturf. Ges.* 19: 1–47.
- Ettingshausen, C. 1883. Beiträge zur Kenntniss der Tertiärflora Australiens. *Kaiserl. Akad. Wiss. Wien, Math.-Naturwiss. Kl., Denkschr.* 47: 101–148.
- . 1888. Contributions to the Tertiary flora of Australia. *Geol. Surv. New South Wales, Mem., Paleontol.*

- Fritsch, A. 1893. Studien in Gebiete der Böhmisschen der kredeformation—Palaeontologische Untersuchungen der einzelnen. Arch. Naturwiss. Landesdurchf. Bohmen 9: 1–134.
- Gevin, P., J.-C. Koeniguer & Y. Lemoigne. 1971. Les bois fossiles du Dalaat el Admia (région de Tindouf, Algérie). Bull. Soc. Geol. France, 7th ser. 13: 386–393.
- Geyer, H. T. 1887. Über fossile Pflanzen von Labuan. Vega-Expen. Vetensk. Arbeten 4: 475–507.
- Graham, A. 1976. Studies in neotropical paleobotany. II. The Miocene communities of Veracruz, Mexico. Ann. Missouri Bot. Gard. 63: 787–842.
- . 1985. Studies in neotropical paleobotany. IV. The Eocene communities of Panama. Ann. Missouri Bot. Gard. 72: 504–534.
- . 1987. Fossil pollen of *Sabicea* (Rubiaceae) from the lower Miocene Culebra Formation of Panama. Ann. Missouri Bot. Gard. 74: 868–870.
- . 1988. Studies in neotropical paleobotany. V. The lower Miocene communities of Panama—The Culebra Formation. Ann. Missouri Bot. Gard. 75: 1440–1466.
- . 1989. Studies in neotropical paleobotany. VII. The lower Miocene communities of Panama—The La Boca Formation. Ann. Missouri Bot. Gard. 76: 50–66.
- . 1991a. Studies in neotropical paleobotany. IX. The Pliocene communities of Panama—Angiosperms (dicots). Ann. Missouri Bot. Gard. 78: 201–223.
- . 1991b. Studies in neotropical paleobotany. X. The Pliocene communities of Panama—Composition, numerical representations, and paleocommunity paleoenvironmental reconstructions. Ann. Missouri Bot. Gard. 78: 465–475.
- . 1999. Late Cretaceous and Cenozoic History of North American Vegetation (north of Mexico). Oxford University Press, Oxford, U.K.
- . 2009. Late Cretaceous and Cenozoic History of Latin American Vegetation and Terrestrial Environments. Missouri Botanical Garden Press, St. Louis (in press).
- & D. L. Dilcher. 1998. Studies in neotropical paleobotany. XII. A palynoflora from the Pliocene Río Banano Formation of Costa Rica and the Neogene vegetation of Mesoamerica. Amer. J. Bot. 85: 1426–1438.
- & D. M. Jarzen. 1969. Studies in neotropical paleobotany. I. The Oligocene communities of Puerto Rico. Ann. Missouri Bot. Gard. 56: 308–357.
- , K. M. Gregory-Wodzicki & K. L. Wright. 2001. Studies in neotropical paleobotany. XV. A Mio-Pliocene palynoflora from the Eastern Cordillera, Bolivia: Implications for the uplift history of the Central Andes. Amer. J. Bot. 88: 1545–1557.
- Gregory-Wodzicki, K. M. 2000. Relationships between leaf morphology and climate, Bolivia: Implications for estimating paleoclimate from fossil floras. Paleobiology 26: 668–688.
- , W. C. McIntosh & K. Velásquez. 1998. Climate and tectonic implications of the late Miocene Jakokkota flora, Bolivian Altiplano. J. S. Amer. Earth Sci. 11: 533–560.
- Gruas-Cavagnetto, C. 1977. Pollens de *Chaetacme* et d'autres Umacées dans le Paléogène du Bassin Anglo-Parisien. Rev. Micropaleontol. 20: 72–76.
- . 1978. Etude palynologique de l'Eocène du Bassin Anglo-Parisien. Mém. Soc. Géol. France, Nouv. Sér., 56, Mém. 131: 1–64.
- Hannibal, H. A. 1911. A Pliocene flora from the Coast Ranges of California. Bull. Torrey Bot. Club 38: 329–342.
- Hansen, B. C. S. 1990. Pollen stratigraphy of Laguna de Cocos. Pp. 155–186 in M. D. Pohl (editor), Ancient Maya Wetland Agriculture, Excavations on Albion Island, Northern Belize. Westview Press, Boulder, Colorado.
- Hector, J. 1880. Fossil plants. Official Catalogue of the New Zealand Court, International Exhibit, Sydney, 1879: 47–50.
- Heer, O. 1868. Allgemeiner Theil. Pp. 1–77 in Flora Fossilis Arctica, Vol. 1, Pt. 1. Friedrich Schulthess, Zurich.
- . 1876. Beiträge zur fossilen Flora Spitzbergens. Pp. 1–141 in Flora Fossilis Arctica, Vol. 4, Pt. 1. J. Wurster & Co., Zurich.
- . 1883. Die Tertiäre Flora von Grönland: Die Fossil Flora Grönlands. Pp. 1–275 in Flora Fossilis Arctica, Vol. 7. J. Wurster & Co., Zurich.
- Heusser, C. J. 1995. Three Late Quaternary pollen diagrams from southern Patagonia and their palaeoecological implications. Palaeogeogr. Palaeoclimatol. Palaeoecol. 118: 1–24.
- , L. E. Heusser & T. V. Lowell. 1999. Paleocology of the southern Chilean Lake District—Isla Grande de Chiloé during middle-late Llanquihue glaciation and deglaciation. Geograf. Ann. 81: 231–284.
- Hofmann, E. 1952. Pflanzenreste aus dem Phosphoritvorkommen von Prambachkirchen in Oberösterreich. Palaeontographica 92: 122–183.
- Hollick, A. 1928. Paleobotany of Porto Rico. Scientific Survey of Porto Rico and the Virgin Islands 7, Pt. 3. New York Academy of Sciences, New York.
- Holmgren, P. K. & N. H. Holmgren. 1998 [continuously updated]. Index Herbariorum: A global directory of public herbaria and associated staff. New York Botanical Garden's Virtual Herbarium. <<http://sweetgum.nybg.org/ih/>>, accessed 2 October 2008.
- Hooghiemstra, H. 1984. Vegetational and climatic history of the High Plain of Bogotá, Colombia: A continuous record of the last 3.5 million years. Diss. Bot. 79: 1–368.
- , A. M. Cleff, G. W. Noldus & M. Kappelle. 1992. Upper Quaternary vegetation dynamics and palaeoclimatology of the La Chonta bog area (Cordillera de Talamanca, Costa Rica). J. Quatern. Sci. 7: 205–225.
- Hoorn, C. 1994a. Miocene Palynostratigraphy and Paleoenvironments of Northwestern Amazonia, Evidence for Marine Incursions and the Influence of Andean Tectonics. Ph.D. Dissertation, University of Amsterdam, Amsterdam.
- . 1994b. An environmental reconstruction of the palaeo-Amazon River System (middle-late Miocene, NW Amazonia). Palaeogeogr. Palaeoclimatol. Palaeoecol. 112: 187–238.
- . 1994c. Fluvial palaeoenvironments in the intracratonic Amazonas Basin (early Miocene-early middle Miocene, Colombia). Palaeogeogr. Palaeoclimatol. Palaeoecol. 109: 1–54.
- Huang, T.-C. 1978. Miocene palynomorphs of Taiwan. II. Tetrad grains. Bot. Bull. Acad. Sin. 19: 77–81.
- Islebe, G. A. & H. Hooghiemstra. 1997. Vegetation and climate history of montane Costa Rica since the last glacial. Quatern. Sci. Rev. 16: 589–604.
- , ———, M. Brenner, J. H. Curtis & D. A. Hodell. 1996. A Holocene vegetation history of lowland Guatemala. Pp. 81–99 in G. A. Islebe (editor), Vegetation, Phytogeography, and Paleo-ecology of the Last 20,000 Years of Montane Central America. University of Amsterdam, Amsterdam.
- Jalaluddin, S. & J. J. Bruhl. 2008. Testing species limits in *Rennellia* (Prismatomerideae, Rubioideae, Rubiaceae). Taxon 57: 43–52.

- Kahan, S. A., S. G. Razafimandimbison, B. Bremer & S. Liede-Schumann. 2008. Sabiceae and Virentariae (Rubiaceae, Ixoroideae): One or two tribes? New tribal and generic circumscriptions of Sabiceae and biogeography of *Sabicea* s.l. *Taxon* 57: 7–23.
- Kesel, R. H. 1983. Quaternary history of the Río General Valley, Costa Rica. *Res. Rep. Natl. Geogr. Soc.* 15: 339–358.
- Khan, A. M. 1976. Palynology of Tertiary sediments from Papua New Guinea. I. New form genera and species from Upper Tertiary sediments. *Austral. J. Bot.* 24: 753–781.
- Kräusel, R. 1939. Ergebnisse der Forschungsreisen Prof. E. Stromers in den Wüsten Ägyptens—[Part] 4, Die fossilen Floren Ägyptens. Bayer. Akad. Wiss., Math.-Naturwiss. Kl., Abh., n.s. 47: 1–140.
- Krutzsch, W. 1970. Zur Kenntnis fossiler disperser Tetradenpollen. *Paläontol. Abh., Abt. B, Paläobot.* 3: 399–433.
- Latorre, C., J. L. Betancourt, K. A. Rylander, J. Quade & O. Matthei. 2003. A vegetation history from the arid prepuna of northern Chile (22–23°S) over the last 13,500 years. *Palaeogeogr. Palaeoclimatol. Palaeoecol.* 194: 223–246.
- Ledru, M.-P., R. Campello Cordeiro R., J. M. Landim Dominguez, L. Martin, P. Mourguiart, A. Sifeddine & B. Turcq. 2001. Late-glacial cooling in Amazonia inferred from pollen at Lagoa do Caçó, northern Brazil. *Quatern. Res.* 55: 47–56.
- Leopold, E. B. 1969. Miocene pollen and spore flora of Eniwetok Atoll, Marshall Islands. *U.S. Geol. Surv. Prof. Paper* 260(II), 1133–1185.
- Lesquereux, L. 1883. Description of Miocene species from specimens obtained in the so-called Bad-lands of Dakota. Contributions to the Fossil Flora of the Western Territories, Pt. III. *U.S. Geol. Surv. Terr. Reports* 8: 221–237.
- Louvet, P. & J. Mouton. 1970. La flore Oligocene du Djebel Coquin (Libye). *Actes 95th Congr. Nat. Soc. Savantes* 3: 79–96.
- Lozano-García, M. S., B. Ortega-Guerrero & S. Sosa-Nájera. 2002. Mid- to late Wisconsin pollen record of San Felipe Basin, Baja California. *Quatern. Res.* 58: 84–92.
- MacPhail, M. K. 1999. Palynostratigraphy of the Murray Basin, inland southeastern Australia. *Palynology* 23: 197–240.
- & D. J. Cantrill. 2006. Age and implications of the Forest Bed, Falkland Islands, southwest Atlantic Ocean: Evidence from fossil pollen and spores. *Palaeogeogr. Palaeoclimatol. Palaeoecol.* 240: 602–629.
- Manchester, S. R. 1994. Fruits and seeds of the middle Eocene nut beds flora, Clarno Formation, Oregon. *Palaeontogr. Amer.* 58: 1–205.
- Mancini, M. V. 1998. Vegetational changes during the Holocene in extra-Andean Patagonia, Santa Cruz Province, Argentina. *Palaeogeogr. Palaeoclimatol. Palaeoecol.* 138: 207–219.
- Mandaokar, B. D. 2003. Palynology and palaeoecological consideration of Middle Bhuban Formation (Miocene), Lawngtlai, Mizoram, India. *Gondwana Geol. Mag. sp. Vol.* 6: 185–193.
- Mania, D. & D. H. Mai. 1969. Warmzeitliche Mollusken und Pflanzenreste aus dem Mittelpleistozän des Geiseltals (südlich von Halle). *Geologie* 18: 674–690.
- Martin, H. A. 1978. Evolution of the Australian flora and vegetation through the Tertiary: Evidence from pollen. *Alcheringa* 2: 181–202.
- Martínez-Cabrera, D., T. Terrazas, H. Flores & H. Ochotorena. 2008. Morphology, anatomy, and taxonomic position of *Plocaniophyllon* Brandegeae (Rubiaceae), a monospecific genus endemic to Mesoamerica. *Taxon* 57: 33–42.
- Mason, H. L. 1934. Pleistocene flora of the Tomales Formation. *Carnegie Inst. Washington Publ.* 415: 81–179.
- Médus, J. 1975. Palynologie de sédiments Tertiaires du Sénégal méridional. *Pollen & Spores* 17: 545–608.
- Menke, B. 1976. Pliozäne und ältestquartäre Sporen- und Pollenflora von Schleswig-Holstein. *Geol. Jahrb., A* 32: 3–197.
- Menzel, P. 1913. Beitrag zur Flora der niederrheinischen Braunkohlenformation. *Preuss. Geol. Landesanst.* 34: 1–98.
- Meyer, H. W. & S. R. Manchester. 1997. The Oligocene Bridge Creek flora of the John Day Formation, Oregon. *Univ. Calif. Publ. Geol. Sci.* 141: 1–195.
- Mildenhall, D. C. 1980. New Zealand Late Cretaceous and Cenozoic plant biogeography: A contribution. *Palaeogeogr. Palaeoclimatol. Palaeoecol.* 31: 197–233.
- & Y. M. Crosbie. 1979. Some porate pollen from the Upper Tertiary of New Zealand. *New Zealand J. Geol. Geophys.* 22: 499–508.
- Moncada Ferrera, M., C. E. Hernández Fuentes & M. Cabrera Castellanos. 1990–1991. Análisis polínico de sedimentos marinos del occidente de la Isla de la Juventud (Cuba). *Acta Bot. Hung.* 36: 145–161.
- Muller, J. 1981. Fossil pollen records of extant angiosperms. *Bot. Rev.* 47: 1–142.
- Paduano, G. M., M. B. Bush, P. A. Baker, S. C. Fritz & G. O. Seltzer. 2003. A vegetation and fire history of Lake Titicaca since the Last Glacial Maximum. *Palaeogeogr. Palaeoclimatol. Palaeoecol.* 194: 259–279.
- Palma-Heldt, S. 1980. Contribución al conocimiento palinológico de los mantos carboníferos del Terciario de Arauco-Concepción, Chile. *Actas 2° Congreso Argentino de Paleontología y Bioestratigrafía y 1° Congreso Latinoamericano de Paleontología*, Buenos Aires, pp. 175–192.
- Perkins, G. H. 1905. Description of species found in the Tertiary lignite of Brandon, Vermont. *Rep. Vermont State Geol.* 1903–04: 174–212.
- Pons, D. 1985. Types biologiques foliaires et paléoenvironnements (Tertiaire de la Moyenne Magdalena, Colombie). *Recherches Nouvelles sur l'Evolution Végétale, Volume Jubilaire en l'honneur du Professeur Edouard Boureau*, Bull. Section Sciences, Paléobotanique 8: 235–257.
- Potbury, S. S. 1932. Pleistocene flora from San Bruno, San Mateo Co., California. *Carnegie Inst. Wash. Publ.* 415: 25–44.
- Prieto, A. R. 2000. Vegetational history of the Late Glacial–Holocene transition in the grasslands of eastern Argentina. *Palaeogeogr. Palaeoclimatol. Palaeoecol.* 157: 167–188.
- Quattrocchio, M. & A. M. Borromei. 1998. Paleovegetational and paleoclimatic changes during the Late Quaternary in southwestern Buenos Aires Province and southern Tierra del Fuego (Argentina). *Palynology* 22: 67–82.
- Romero, E. J. 1986. Paleogene phytogeography and climatology of South America. *Ann. Missouri Bot. Gard.* 73: 449–461.
- Roth, J. L. Jr. & D. L. Dilcher. 1979. Investigations of angiosperms from the Eocene of North America: Stipulate leaves of the Rubiaceae including a probable polyploid population. *Amer. J. Bot.* 66: 1194–1207.
- Salard-Cheboldaeff, M. 1978. Sur la palynoflore Maestrichtienne et Tertiaire du bassin sédimentaire littoral du Cameroun. *Pollen & Spores* 20: 215–260.
- Salgado-Labouriau, M. L. 1980. A pollen diagram of the Pleistocene–Holocene boundary of Lake Valencia, Venezuela. *Rev. Palaeobot. Palynol.* 30: 297–312.

- Scholtz, A. 1985. The palynology of the upper lacustrine sediments of the Arnot Pipe, Banke, Namaqualand. *Ann. S. Afr. Mus.* 95: 1–109.
- Singewald, J. T. Jr. & E. W. Berry. 1922. The geology of the Corocoro Copper District of Bolivia. *Johns Hopkins Univ. Stud. Geol.* 1: 1–117.
- Smedmark, J. E. E., C. Rydin, S. G. Razafimandimbison, S. A. Khan, S. Liede-Schumann & B. Bremer. 2008. A phylogeny of Urophylleae (Rubiaceae) based on *rps16* intron data. *Taxon* 57: 24–32.
- Tiffney, B. H. 1977. Fruits and seeds of the Brandon Lignite: Magnoliaceae. *Bot. J. Linn. Soc.* 75: 299–323.
- & A. Traverse. 1994. The Brandon Lignite (Vermont) is of Cenozoic, not Cretaceous, age! *N. E. Geol.* 16: 215–220.
- Traverse, A. 1955. Pollen analysis of the Brandon Lignite of Vermont. U.S. Dept. Interior, Washington, D.C., Bureau of Mines Rep. Invest. 5151.
- . 1994. Palynofloral geochronology of the Brandon Lignite of Vermont, USA. *Rev. Palaeobot. Palynol.* 82: 265–297.
- Unger, F. 1850. *Genera et Species Plantarum Fossilium*. 8 vols. Wilhelm Braumüller, Vienna.
- . 1865. *Sylogé Plantarum Fossilium—Sammlung Fossiler Pflanzen besonders aus der Tertiär-Formation*. *Kgl. Akad. Wiss. Wien. Denkschr.* 25: 1–76.
- van Campo, E. 1976. *La Flore Sporopollénique du Gisement Miocène Terminal de Venta del Moro (Espagne)*. Thesis, Montpellier, France.
- van der Hammen, T. & M. L. Asby. 1994. Amazonia during the last glacial. *Palaeogeogr. Palaeoclimatol. Palaeoecol.* 109: 247–261.
- van Devender, T. R. 1990. Late Quaternary vegetation and climate of the Chihuahuan Desert, United States and Mexico. Pp. 104–133 in J. L. Betancourt, T. R. van Devender & P. S. Martin (editors), *Packrat Middens: The Last 40,000 Years of Biotic Change*. University of Arizona Press, Tucson.
- van Hoeken-Klinkenberg, P. M. J. 1964. A palynological investigation of some Upper-Cretaceous sediments in Nigeria. *Pollen & Spores* 6: 209–231.
- Watt, A. D. 1982. Index of Generic Names of Fossil Plants, 1974–1978. *U.S. Geol. Surv. Bull.* 1517: 1–63.
- Wehr, W. C. & S. R. Manchester. 1996. Paleobotanical significance of Eocene flowers, fruits, and seeds from Republic, Washington. *Washington Geol.* 24: 25–27.
- Wessel, P. & O. Weber. 1855. *Neuer Beiträge zur Tertiärflora der niederrheinischen Braunkohlenformation*. *Palaeontographica* 4: 111–168.
- White, J. M. & T. A. Ager. 1994. Palynology, paleoclimatology, and correlation of middle Miocene beds from Porcupine River (Locality 90-1), Alaska. *Quatern. Int.* 22/23: 43–77.
- Wijninga, V. M. 1996. *Paleobotany and Palynology of Neogene Sediments from the High Plain of Bogotá (Colombia), Evolution of the Andean Flora from a Paleoeological Perspective*. Ph.D. Dissertation, University of Amsterdam, The Netherlands.
- Wilf, P., K. R. Johnson, N. R. Cúneo, M. E. Smith, B. S. Singer & M. A. Gandolfo. 2005. Eocene plant diversity at Laguna del Hunco and Río Pichileufu, Argentina. *Amer. Naturalist* 165: 634–650.
- Zamaloa, M. 2000. Palinoflora y ambiente en el Terciario del nordeste de Tierra del Fuego, Argentina. *Revista Mus. Argent. Ci. Nat., n.s.* 2: 43–51.

PHYLOGENY OF THE
HERBACEOUS TRIBE
SPERMACOCEAE (RUBIACEAE)
BASED ON PLASTID DNA DATA¹

Inge Groeninckx,² Steven Dessein,^{2,3}
Helga Ochoterena,⁴ Claes Persson,⁵
Timothy J. Motley,⁶ Jesper Kårehed,⁷
Birgitta Bremer,⁷ Suzy Huysmans,²
and Erik Smets^{2,8}

ABSTRACT

In its current circumscription, the herbaceous tribe Spermacoceae s.l. (Rubiaceae, Rubioideae) unites the former tribes Spermacoceae s. str., Manettieae, and the *Hedyotis–Oldenlandia* group. Within Spermacoceae, and particularly within the *Hedyotis–Oldenlandia* group, the generic delimitations are problematic. Up until now, molecular studies have focused on specific taxonomic problems within the tribe. This study is the first to address phylogenetic relationships within Spermacoceae from a tribal perspective. Sequences of three plastid markers (*atpB-rbcL*, *rps16*, and *trnL-trnF*) were analyzed separately as well as combined using parsimony and Bayesian approaches. Our results support the expanded tribe Spermacoceae as monophyletic. The former tribe Spermacoceae s. str. forms a monophyletic clade nested within the *Hedyotis–Oldenlandia* group. Several genera formerly recognized within the *Hedyotis–Oldenlandia* group are supported as monophyletic (*Amphiasma* Bremek., *Arcytophyllum* Willd. ex Schult. & Schult. f., *Dentella* J. R. Forst. & G. Forst., *Kadua* Cham. & Schldl., and *Phylohydrax* Puff), while others appear to be paraphyletic (e.g., *Agathisanthemum* Klotzsch), biphyletic (*Kohautia* Cham. & Schldl.), or polyphyletic (*Hedyotis* L. and *Oldenlandia* L. sensu Bremekamp). Morphological investigations of the taxa are ongoing in order to find support for the many new clades and relationships detected. This study provides a phylogenetic hypothesis with broad sampling across the major lineages of Spermacoceae that can be used to guide future species-level and generic studies.

Key words: *atpB-rbcL*, *Hedyotis–Oldenlandia* group, Rubiaceae, molecular phylogeny, plastid DNA, *rps16*, Spermacoceae, *trnL-trnF*.

The systematic relationships of the Rubiaceae herbaceous representatives are still unclear at the species and genus levels (Robbrecht & Manen, 2006). Even the higher-level classification in tribes has been the subject of debate. In the last comprehensive classification based on morphology (Robbrecht, 1988, 1993), most herbaceous representatives were assigned to one of the following tribes: Anthospermeae, Argostemmatae, Coccocypseleae, Hedyotideae, Knoxieae, Rubieae, Sipaneeae, Spermacoceae, and Theligoneae. Among these, the Spermacoceae as traditionally delimited (Hooker, 1873; Bremekamp, 1952, 1966; Verdcourt, 1958; Robbrecht, 1988, 1993), referred to in this

paper as Spermacoceae s. str., are characterized by the presence of raphides, fimbriate stipules, uniovulate locules, seeds with an apparent adaxial groove, and the frequent occurrence of pluriaperturate pollen grains. However, molecular data show Spermacoceae s. str. to be deeply nested within the Hedyotideae, making the latter tribe paraphyletic (Bremer, 1996; Andersson & Rova, 1999; Bremer & Manen, 2000; Dessein et al., 2005a). Therefore, Bremer (1996) and later Bremer and Manen (2000) proposed a wider definition for Spermacoceae, in which the former tribes Spermacoceae s. str., Hedyotideae, Manettieae, Knoxieae, and Trainolepideae are merged.

¹ We thank the organizers of the Third International Rubiaceae Conference and the editors of this volume for the invitation to participate in the proceedings. We acknowledge the technical assistance of Anja Vandepierre from the Laboratory of Plant Systematics, Katholieke Universiteit Leuven. Frank van Caekenberghe from the National Botanic Garden of Belgium is thanked for providing lovely photographs of Spermacoceae. This research was supported by grants from the Fund for Scientific Research–Flanders (FWO, G.0250.05 and G.0268.04). Inge Groeninckx holds a Ph.D. research grant from the Fund for Scientific Research–Flanders.

² Laboratory of Plant Systematics, Katholieke Universiteit Leuven, Kasteelpark Arenberg 31, P.O. Box 2437, BE-3001 Leuven, Belgium. Author for correspondence: inge.groeninckx@bio.kuleuven.be.

³ National Botanic Garden of Belgium, Domein van Bouchout, BE-1860 Meise, Belgium.

⁴ Instituto de Biología, Universidad Nacional Autónoma de México, Apdo. Postal 70-367, 04510, México.

⁵ Department of Plant and Environmental Sciences, Göteborg University, P.O. Box 461, SE-405 30 Göteborg, Sweden.

⁶ Department of Biological Sciences, Old Dominion University, 110 Mills Godwin Building, 45th Street, Norfolk, Virginia 23529-0266, U.S.A.

⁷ Bergius Foundation, Royal Swedish Academy of Sciences and Botany Department, Stockholm University, SE-106 91 Stockholm, Sweden.

⁸ National Herbarium of the Netherlands, Leiden University Branch, P.O. Box 9514, NL-2300 RA Leiden, The Netherlands. doi: 10.3417/2006201

Based on *rps16* intron data, Andersson and Rova (1999) also found that Hedyotideae is paraphyletic relative to Spermaceae s. str. They did not accept the wide delimitation for Spermaceae as proposed by Bremer (1996), but suggested an emended tribe Knoxieae that included a few genera of Hedyotideae (i.e., *Otiophora* Zucc., *Otomeria* Benth., and *Pentas* Benth.) as a more prudent taxonomic approach to handle the information from molecular-based analyses. The latter view was followed by Dessein (2003), who preferred to recognize an emended tribe Knoxieae (including Knoxieae s. str., Triainolepideae, *Otiophora*, the *Pentas* group of Hedyotideae fide Dessein et al. [2000], and *Carphalea* Juss.) as a sister group of Spermaceae (including Spermaceae s. str., Manettieae, and most of Hedyotideae). Robbrecht and Manen (2006), based on a supertree analysis of the family, came to a similar conclusion and likewise recognized Knoxieae s.l. and Spermaceae s.l. The monophyly of the former tribe has also been confirmed by a subsequent molecular study by Kårehed and Bremer (2007). In their taxonomic conspectus, Robbrecht and Manen (2006) listed 33 genera of Spermaceae s.l. for which molecular sequence data are available. Based on morphological data, we recognize 31 of these 33 genera and consider that the tribe should include 30 additional genera; these are listed in Table 1. For each genus, the number of species, the distribution, and the position in Robbrecht's classification of 1988 are given.

Spermaceae s.l. forms a primarily herbaceous lineage that is generally characterized by fimbriate stipules and 4-merous flowers. Floral characters (Fig. 1), as well as seeds and fruits, are highly variable. Morphologically, three main groups can be identified within Spermaceae s.l. The first, the *Hedyotis*–*Oldenlandia* group, is characterized by multiovulate locules and comprises the large genera *Hedyotis* L. and *Oldenlandia* L. and their presumed relatives. Most of these taxa were formerly placed in the tribe Hedyotideae. The generic delimitations of the *Hedyotis*–*Oldenlandia* group have been the subject of controversy for many years. The main issue is whether most species of the complex should be lumped into *Hedyotis* (advocated by inter alia Merrill & Metcalf, 1946; Wagner et al., 1989; Fosberg & Sachet, 1991; Dutta & Deb, 2004) or whether many small genera should be recognized in addition to a narrow circumscription of *Hedyotis* and *Oldenlandia* (supported for African taxa by Bremekamp, 1952; for Neotropical taxa by Terrell et al., 1986; Terrell, 1991, 2001a, b, c; and for Asian taxa by Terrell & Robinson, 2003).

The second well-marked group within Spermaceae s.l. is Spermaceae s. str., which is character-

ized by uniovulate locules. According to Dessein (2003), this group contains 19 genera of which *Spermace* L. is by far the largest with an estimated 275 species. Within Spermaceae s. str., controversy has focused on the delimitation of its nominal genus *Spermace*. The main question is whether *Spermace* should be limited to species with the same type of fruit dehiscence as *S. tenuior* L., the type species of the genus. In this species, fruits open asymmetrically, resulting in one closed and one open fruit part. If this narrow delimitation for *Spermace* (referred to as *Spermace* s. str.) is accepted, most other species in the tribe Spermaceae s. str. must be included in *Borreria* G. Mey.

A third well-defined group within Spermaceae s.l. comprises only two American genera, *Bouvardia* Salisb. and *Manettia* Mutis ex L. Bremekamp (1952) considered *Bouvardia* closely related to *Heterophyllaea* Hook. f., *Hindsia* Benth. ex Lindl., and *Lecanosperma* Rusby. Robbrecht (1988) placed these genera together with inter alia *Manettia* in a group with uncertain affinities, because their winged seeds suggest a relation to Cinchoneae, while the presence of raphides indicates a relation to Hedyotideae. In the classification of Bremer and Manen (2000), only *Bouvardia* and *Manettia* belong to Spermaceae s.l., because *Hindsia* and *Heterophyllaea* (including *Lecanosperma*) are included in Coussareeae. *Manettia* is similar to *Bouvardia* in many characters, but its winding shoots and corneous endosperm separate it from *Bouvardia*, which is erect and has fleshy endosperm. These differences were the basis for Bremekamp (1934) to place *Manettia* in its own tribe, Manettieae.

Until now, molecular studies within Spermaceae s.l. have focused on particular taxonomic problems, such as the circumscription and biogeography of *Arcytophyllum* Willd. ex Schult. & Schult. f. (Andersson et al., 2002), the generic status of *Houstonia* L. (Church, 2003), the delimitation of *Pentanopsis* Rendle, the affinities of *Phylohydrax* Puff (Thulin & Bremer, 2004), and the taxonomic position of *Gomphocalyx* Baker (Dessein et al., 2005a). In the present paper, we aim to present a phylogenetic hypothesis of Spermaceae s.l. based on the analysis of three plastid markers (*atpB-rbcL*, *rps16*, and *trnL-trnF*) with the broadest sampling to date. More specifically, we want to address the following questions: (1) Is Spermaceae s.l. as circumscribed by Robbrecht and Manen (2006) monophyletic? (2) What are the relationships among members of Spermaceae s. str. and genera of the former tribes Hedyotideae and Manettieae? (3) What are the major clades within the *Hedyotis*–*Oldenlandia* group?

MATERIAL AND METHODS

PLANT MATERIAL AND SAMPLING

The aim was to obtain a broad sampling covering most of the geographic and taxonomic diversity of Spermaceae and to enable identification of the principal clades within the tribe. We included a total of 128 species representing 32 of the 61 genera within Spermaceae. Three taxa belonging to the Knoxieae (*Batopedina pulvinellata* Robbr., *Carphalea madagascariensis* Lam., and *Pentanisia parviflora* Stapf ex Verdc.) were chosen as outgroup following Robbrecht and Manen (2006) and Kårehed and Bremer (2007). For *rps16* and *trnL-trnF*, we used 40 and seven previously published sequences, respectively (Anderson & Rova, 1999; Andersson et al., 2002; Dessein et al., 2005a). Two hundred seventy-two sequences are newly generated (100 *atpB-rbcL* sequences, 67 *rps16* sequences, 105 *trnL-trnF* sequences) using dried silica and herbarium material. Appendix 1 lists all taxa included in this study with voucher information and GenBank accession numbers.

DNA EXTRACTION, POLYMERASE CHAIN REACTION AMPLIFICATION, AND SEQUENCING

DNA was extracted from silica-dried and herbarium material using the CTAB method as described by Janssens et al. (2006). Amplification of the *atpB-rbcL* spacer was done with oligonucleotides two and five as primers (Manen et al., 1994). Specific amplification products could be obtained with a touchdown polymerase chain reaction (PCR) with two cycles with an annealing temperature of 53°C, then 12 cycles with an annealing temperature of 52.5°C declining 0.5°C every cycle, followed by 16 cycles with an annealing temperature of 47°C. The *rps16* intron was amplified with the *rps16F* and *rps16R2* primers described by Oxelman et al. (1997). For the *trnL-trnF* intergenic spacer, we used the primers e and f of Taberlet et al. (1991). Both *rps16* and *trnL-trnF* were amplified using standard PCR techniques with an annealing temperature of 55°C. The PCR reaction mixture was cleaned using a Nucleospin Extraction II Kit (Machery-Nagel, Dren, Germany) according to the manufacturer's instructions. Sequencing was mostly done on an ABI 310 Genetic Analyzer (Applied Biosystems, Lennik, Belgium). Some PCR products were sequenced by Macrogen (Seoul, South Korea) sequencing facilities.

SEQUENCE ASSEMBLY, ALIGNMENT, AND GAP CODING

The assembling and editing of sequences were conducted using the Staden Package (Staden et al.,

1998). Sequences were initially aligned with ClustalX (Thompson et al., 1997) applying the default parameters. Further adjustments of the preliminary aligned data matrices were done manually with MacClade 4.04 (Maddison & Maddison, 2001). Parsimonious informative gaps were coded manually according to the conservative simple indel coding method described by Simmons and Ochoterena (2000).

PHYLOGENETIC ANALYSES

Phylogenetic analyses were conducted using both parsimony (MP) and Bayesian inference (BI). The three plastid regions were first analyzed separately and then combined.

Equally weighted MP analyses were performed using Nona 2.0 (Goloboff, 1993) launched through WinClada 1.00.08 (Nixon, 2002). Heuristic searches for the shortest trees were performed using the parsimony ratchet (Nixon, 1999). Ratchet runs of 200 iterations each, holding one tree per iteration and randomly weighting 10% of the potentially informative characters, were carried out until the most parsimonious trees (MPTs) were repeatedly found. A strict consensus tree was calculated using the trees obtained in the parsimony ratchet analyses. In order to evaluate the relative support of the clades, jackknife and bootstrap analyses were executed using 1000 replicates with 10 initial trees holding five trees per random addition, doing tree bisection-reconnection (TBR) to hold 1000 trees, and calculating a consensus on each repetition. Frequency values were plotted onto the consensus of the MPTs.

For the BI analyses, a substitution model was selected for each DNA region with Modeltest 3.06 (Posada & Crandall, 1998) under the Akaike Information Criterion (AIC). Modeltest selected the GTR+I+G model of evolution for the *atpB-rbcL* spacer and the GTR+G model for the two remaining markers. Indels were not included in the BI analyses. In the combined analysis, a mixed-model approach was used (Ronquist & Huelsenbeck, 2003). The combined data were partitioned and the same models of evolution were used on the partitions as selected for the single analyses. The BI analyses were conducted with MrBayes 3b4 (Huelsenbeck & Ronquist, 2001). Four Markov chains (one cold, three heated) starting with a random tree were run simultaneously for one million generations, sampling trees at every 100 generations. The first 2500 sampled trees (25%) were regarded as burn-in and discarded. PAUP* version 4b10 (Swofford, 2002) was used to calculate a 50% majority rule tree and to report the posterior probabilities for each clade. Only posterior probabilities above 0.95 are considered (Suzuki et al., 2002).

Table 1. List of genera associated with Spermaceae s.l., their distribution, and species number following Govaerts et al. (2006), except when stated otherwise. Genera in boldface were listed by Robbrecht and Manen (2006); other genera are here based on morphological similarities. Synonymous taxa are as given by Robbrecht (1988), except when stated otherwise.

Genus	Robbrecht, 1988	Native distribution	No. of species	Sampled
Agathisanthemum Klotzsch	Hed	tropical and S Africa, Comoros	4	yes
Amphiasma Bremek.	Hed	tropical and S Africa	7	yes
<i>Anthospermopsis</i> (K. Schum.) J. H. Kirkbr.	Spe	NE Brazil	1	no
Arcytophyllum Willd. ex Schult. & Schult. f.	Hed	Mexico to W South America	17	yes
<i>Astiella</i> Jovet	Hed	Madagascar	1	no
Bouvardia Salisb.	Cin/Hed	S U.S.A., Mexico to C America	42	yes
<i>Bradea</i> * Standl. ex Brade	Hed	SE Brazil	5	no
<i>Carterella</i> Terrell	Hed	Mexico	1	no
Conostomium (Stapf) Cufod.	Hed	Ethiopia to S Africa	5	yes
Crusea Cham. & Schldl.	Spe	Arizona, New Mexico, Mexico to C America	14	yes
Dentella J. R. Forst & G. Forst.	Hed	tropical and subtropical Asia to SW Pacific	8	yes
<i>Diacrodon</i> Sprague	Spe	Brazil	1	no
Dibrachionostylus Bremek.	Hed	E Tropical Africa	1	yes
<i>Denscantia</i> E. L. Cabral & Bacigalupo	Spe	E Brazil	4	no
<i>Diodella</i> Small ⁽¹⁾	Spe	S U.S.A. to S America	16	yes
Diodia L. ⁽¹⁾	Spe	S U.S.A. to S America	5	no
<i>Dolichometra</i> K. Schum.	Hed	Tanzania	1	no
Emmeorhiza Pohl ex Endl.	Spe	S tropical America and Trinidad	1	yes
Ernodea Sw. ⁽²⁾	Spe	Florida, Mexico to C America, Caribbean	4	yes
Galianthe Griseb. ⁽³⁾	Spe	S and C America	50	yes
Gomphocalyx Baker	Spe	Madagascar	1	yes
Hedyotis L.	Hed	tropical and subtropical Asia to NW Pacific	ca. 115	yes
<i>Hedythyrus</i> Bremek.	Hed	C and E tropical Africa	2	yes
Houstonia L. ⁽⁴⁾	Hed	N and C America	20	yes
Hydrophylax L. f.	Spe	India, Sri Lanka, Thailand	1	no
<i>Kadua</i> Cham. & Schldl. (incl. <i>Gouldia</i> A. Gray and <i>Wiegmannia</i> Meyen) ⁽⁵⁾	Spe	Hawaiian Islands to S Pacific	28	yes
Kohautia Cham. & Schldl. ⁽⁶⁾	Hed	Africa, Madagascar, and Asia	31	yes
Lelya Bremek.	Hed	tropical Africa	1	yes
<i>Leptomischus</i> * Drake	Hed	Assam to China	7	no
<i>Leptoscela</i> Hook. f.	Hed	NE Brazil	1	no
<i>Lucya</i> DC.	Hed	Caribbean	1	no
Manettia Mutis ex L.	Cin/Hed	tropical America	124	yes
Manostachya Bremek.	Hed	C and E tropical Africa	3	yes
<i>Micrasepalum</i> Urb.	Spe	Caribbean	2	no
Mitracarpus Zucc. ex Schult. & Schult. f.	Spe	tropical America, naturalized elsewhere	58	yes
Mitrasacmopsis Jovet	Hed	C and E tropical Africa and Madagascar	1	yes
<i>Neanotis</i> W. H. Lewis	Hed	tropical and subtropical Asia	33	no
<i>Neohymenopogon</i> * Bennet	Cin/Hed	E Himalaya, Tibet, SC China, N Indo-China	3	no
Nesohedyotis (Hook. f.) Bremek.	Hed	St. Helena	1	yes
<i>Nodocarpaea</i> A. Gray	Spe	Cuba	1	no
Oldenlandia L. (incl. <i>Eionitis</i> Bremek., <i>Exallage</i> Bremek., and <i>Thecorchus</i> Bremek.)	Hed	pantropical	ca. 240	yes
<i>Oldenlandiopsis</i> Terrell & W. H. Lewis	Hed	tropical and subtropical America	1	no
Pentanopsis Rendle	Hed	Ethiopia to N Kenya	2	yes
Pentodon Hochst.	Hed	tropical and S Africa, Arabian Pen., W Indian Ocean, naturalized in America	2	yes
<i>Phyllocrater</i> Wernham	Hed	Borneo	1	no
Phylohydrax Puff	Spe	coastal Tanzania to S Africa, Madagascar	2	yes

Table 1. Continued.

Genus	Robbrecht, 1988	Native distribution	No. of species	Sampled
<i>Pleiocraterium</i> Bremek.	Hed	tropical Asia	4	no
<i>Polyura</i> * Hook. f.	Hed	E Himalaya to Assam	1	no
<i>Pseudonesohedyotis</i> Tennant	Hed	Tanzania	1	no
<i>Psyllocarpus</i> Mart. & Zucc.	Spe	Brazil	9	no
<i>Richardia</i> L.	Spe	tropical and subtropical America, naturalized elsewhere	16	yes
<i>Sacosperma</i> * G. Taylor	Hed	W and C tropical Africa	2	no
<i>Schwendenera</i> K. Schum.	Spe	Brazil	1	no
<i>Spermaceae</i> L. (incl. <i>Borreria</i> G. Mey. and <i>Hemidiodia</i> K. Schum.) ⁽¹⁾	Spe	pantropical	250–300	yes
<i>Staelia</i> Cham. & Schtdl.	Spe	Mexico and S tropical America	14	no
<i>Stenaria</i> (Raf.) Terrell	Hed	C and E U.S.A. to Mexico, Bahamas	5	yes
<i>Stenotis</i> Terrell	Hed	Mexico (Baja California)	7	no
<i>Stephanococcus</i> Bremek.	Hed	WC tropical Africa	1	no
<i>Synaptantha</i> Hook. f.	Hed	Australia	2	yes
<i>Tobagoa</i> Urb.	Spe	Panama to Tobago	1	no
<i>Tortuella</i> Urb.	Spe	Île de la Tortue (Haiti)	1	no

Hed, Hedyotideae; Spe, Spermaceae s. str.; Cin, Cinchoneae.

⁽¹⁾ – Bacigalupo & Cabral (1999); ⁽²⁾ – Negrón-Ortiz & Hickey (1996); ⁽³⁾ – Cabral (1991); ⁽⁴⁾ – Terrell (1996); ⁽⁵⁾ – Terrell et al. (2005); ⁽⁶⁾ – Mantell (1985); ⁽⁷⁾ – Dessein (2003).

* Tentatively included.

RESULTS

Sequence data from the aligned *atpB-rbcL*, *rps16*, and *trnL-F* regions were analyzed independently and in a combined analysis (Table 2). Individual plastid sequence analyses were topologically congruent. Therefore, only the results from the MP and BI analysis of the combined matrix are presented (Figs. 2–4). Compared to the topologies of the individual plastid sequence analyses, the combined plastid trees show increased resolution and branch support. The Bayesian tree is somewhat better resolved than the consensus of the MP analysis, but more resolved lineages have low posterior probabilities.

Spermaceae s.l., as delimited in the introduction (Table 1), form a well-supported monophyletic group (jackknife support [JS] – 100, bootstrap support [BS] – 100, posterior probability [PP] – 1), as can be seen in Figure 2. A highly supported pentamerous-flowered clade including *Dentella* J. R. Forst. & G. Forst. and *Pentodon* Hochst. (JS – 100, BS – 99, PP – 1) is resolved as sister to the rest of the tribe (Fig. 2). The remaining ingroup taxa are part of a clade that lacks significant jackknife and bootstrap support and has only weak posterior probability (PP – 0.84). Within this clade, stars with Roman numerals I to III are assigned to the three deeper internal nodes that have reasonable support. These three clades are discussed in the following paragraphs.

Clade I in Figure 2 (JS – 88, BS = 77, PP = 1) includes a *Kohautia* subg. *Kohautia* Verdc. clade sister to a clade that includes *Pentanopsis* and allied genera. This *Pentanopsis* clade (JS – 95, BS – 95, PP – 1) is similar to that proposed by Thulin and Bremer (2004). However, our larger sampling resulted in a broader circumscription adding *Gomphocalyx*, *Oldenlandia affinis* (Roem. & Schult.) DC., *O. herbacea* (L.) Roxb., and *O. rosulata* K. Schum. Our results support the monophyly of both *Amphasma* Bremek. (JS – 98, BS – 98, PP – 1) and *Phylohydrax* (JS – 93, BS – 95, PP – 1).

In clade II (JS – 88, BS – 83, PP – 1) of Figure 2, all Asian and Micronesian *Hedyotis* species, except *H. tenelliflora* Blume, are part of a strongly supported *Hedyotis* s. str. clade (JS – 100, BS = 100, PP = 1), which is sister to a clade including *Agathisanthemum* Klotzsch and its allies. This clade of Asian and Micronesian *Hedyotis* species also includes *H. fruticosa* L., the type species of the genus. Relationships within this *Hedyotis* s. str. clade remain mostly unresolved. Within the *Agathisanthemum* clade, *Agathisanthemum* is paraphyletic to *Lelya osteocarpa* Bremek. (JS – 100, BS – 99, PP – 1), both sister to a lineage of African (*Oldenlandia angolensis* K. Schum. and *O. goreensis* (DC.) Summerh.) and North American (*O. uniflora* L.) *Oldenlandia* species (JS – 100, BS – 99, PP – 1).

In the MP consensus, clade II is sister to clade III (Figs. 2A, 3A). However, this sister relationship lacks

significant jackknife and bootstrap support and is not recovered in the BI (Figs. 2B, 3B).

Within clade III (Figs. 3, 4), the earlier derived clades lack significant support values in the MP consensus (Figs. 3A, 4A) and are collapsed in the BI (Figs. 3B, 4B). Therefore, relationships between the different subclades of clade III should be interpreted with caution. In the following paragraphs, these subclades are discussed individually.

In Figure 3, the monospecific genus *Dibrachionostylus* Bremek. is sister to a clade of African *Oldenlandia* species (*O. echinulosa* K. Schum., *O. geophila* Bremek., and *O. nervosa* Hiern). However, this sister relationship lacks significant jackknife and bootstrap support (Fig. 3A) and is not supported by the BI (Fig. 3B). The sister relationship of this clade with respect to *Mitrasacmopsis* Jovet and its allies also lacks support. *Mitrasacmopsis*, another monospecific genus in the *Hedyotis*–*Oldenlandia* group, is nevertheless highly supported as sister to *Hedythyrus* Bremek. (JS – 99, BS – 97, PP – 1), and both are sister to *O. fastigiata* Bremek. (JS – 99, BS – 99, PP – 1).

The genus *Kadua* Cham. & Schltld. (including *Oldenlandia biflora* L.) is resolved as monophyletic with moderate jackknife and bootstrap support but maximum Bayesian posterior probability (JS – 87, BS – 86, PP – 1). The Hawaiian *Kadua* species are unresolved with respect to the French Polynesian species, *K. rapensis* F. Br. The genus *Kadua* shares a most recent common ancestor with all sampled Australian taxa (*O. galioides* (F. Muell.) F. Muell., *O. mitrasacmoides* F. Muell., and *Synaptantha tillaeacea* (F. Muell.) Hook. f.), the Austro-Asian species *Hedyotis tenelliflora*, and the African species *O. lancifolia* (Schumach.) DC. (JS – 91, BS – 86, PP – 1).

The genus *Arcytophyllum* is strongly supported as monophyletic by our analysis (JS – 93, BS – 92, PP – 1). It is sister to a clade of North and Central American species of *Houstonia*, *Oldenlandia*, and *Stenaria* (Raf.) Terrell. The *Houstonia* species plus *S. nigricans* (Lam.) Terrell form one clade, although without significant support.

In Figure 4, Spermaceae s. str. is nested within the *Hedyotis*–*Oldenlandia* group. In the MP consensus (Fig. 4A), it forms a monophyletic lineage (although lacking significant jackknife support and bootstrap support), while in the BI tree (Fig. 4B), *Nesohedyotis arborea* (Roxb.) Bremek. is nested within the Spermaceae s. str. clade (although with low PP = 0.77). In both MP and BI analysis, Spermaceae s. str. has uncertain relationships with respect to *Arcytophyllum serpyllaceum* (Schltld.) Terrell, *Bouvardia*, *Manettia*, *Nesohedyotis* (Hook. f.) Bremek. (Fig. 4A), *O. tenuis* K. Schum., and *O. salzmännii*

(DC.) Benth. & Hook. f. ex B. D. Jacks. Sister to this polytomy is a clade with species of *Kohautia* subg. *Pachystigma* Bremek. and *Oldenlandia* species, including the type species *O. corymbosa* L. (JS – 99, BS – 98, PP – 1). Consequently, species of the genus *Kohautia* Cham. & Schltld. fall in two well-supported, not closely related clades, which correspond to the two described subgenera: subgenus *Kohautia* (JS – 99, BS – 99, PP – 1) and subgenus *Pachystigma* (JS – 96, BS – 96, PP – 1).

DISCUSSION

Our analysis corroborates the monophyly of Spermaceae s.l. (Table 1), a mainly herbaceous assemblage distributed pantropically, with only a few genera penetrating into more temperate regions. The morphological variation is considerable, but the fimbriate stipules and tetramerous flowers are shared by most species. There are no clear morphological synapomorphies that separate Spermaceae s.l. from its sister tribe, the emended Knoxieae. The main differences are listed in Table 3.

Our analyses show several major evolutionary lineages within Spermaceae s.l. and allow us to evaluate the monophyly of a number of genera. Several genera that have been recognized within the *Hedyotis*–*Oldenlandia* group are supported here as monophyletic (*Amphasma*, *Arcytophyllum*, *Dentella*, *Kadua*, and *Phylohydrax*), while others appear to be paraphyletic (e.g., *Agathisanthemum*), biphyletic (*Kohautia*), or polyphyletic (*Hedyotis* and *Oldenlandia* sensu Bremekamp). These groups are discussed in the following paragraphs.

SPERMACEAE S. STR.

In our analyses, Spermaceae s. str. is nested within the *Hedyotis*–*Oldenlandia* group, which no longer makes it possible to recognize this lineage at a tribal level. Additionally, Spermaceae s. str. as delimited by Robbrecht (1988) is not corroborated as monophyletic. Both MP and BI analyses show that it is necessary to exclude *Gomphocalyx* and *Phylohydrax* for Spermaceae s. str. to be monophyletic, which is in agreement with Thulin and Bremer (2004) and Dessein et al. (2005a).

In the BI analyses, *Nesohedyotis arborea*, a species previously included in Hedyotideae, is placed within Spermaceae s. str. as sister to *Emmeorhiza umbellata* (Spreng.) K. Schum., but lacking significant posterior probability (PP – 0.67). This position of *Nesohedyotis* within Spermaceae s. str. was not recovered in the MP analysis. Because no morphological characters can be found to support *Nesohed-*

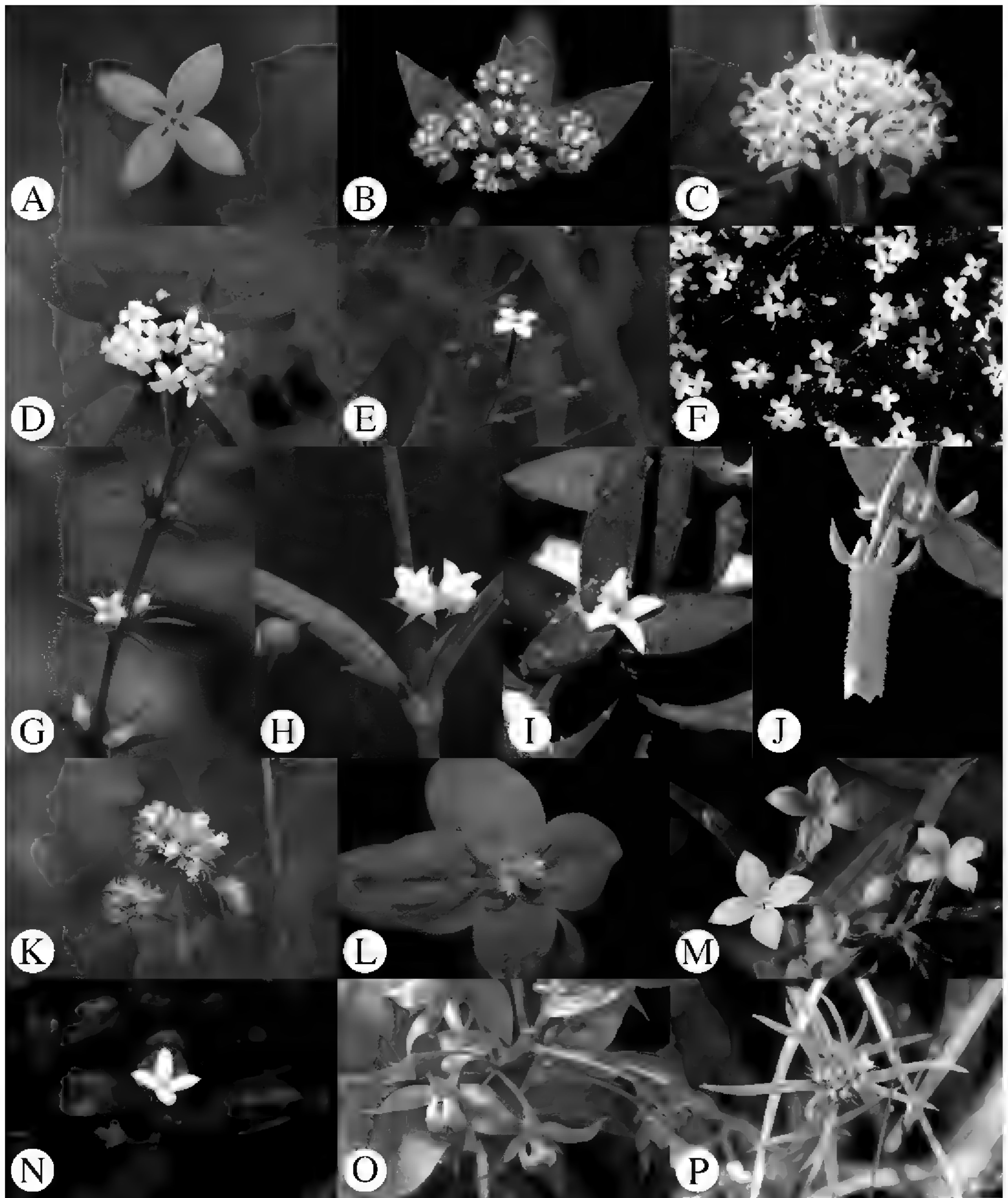

Figure 1. Floral diversity among species of Spermaceae. —A. *Kohautia microcala* Bremek. —B. *Hedythyrus spermacocinus* (K. Schum.) Bremek. —C. *Mitracarpus frigidus* (Willd. ex Roem. & Schult.) K. Schum. —D. *Spermacoce debilis* Benth. —E. *Oldenlandia herbacea* (L.) Roxb. —F. *Gomphocalyx herniarioides* Baker. —G. *Manostachya ternifolia* E. S. Martins. —H. *Oldenlandia lancifolia* (Schumach.) DC. —I. *Phylohydrax madagascariensis* (Willd. ex Roem. & Schult.) Puff. —J. *Manettia luteorubra* (Vell.) Benth. —K. *Agathisanthemum globosum* (Hochst. ex A. Rich.) Klotzsch. —L. *Oldenlandia goreensis* (DC.) Summerh. —M. *Kohautia coccinea* Royle. —N. *Oldenlandia biflora* L. —O. *Kadua acuminata* Cham. & Schltdl. —P. *Oldenlandia robinsonii* Pit.

yotis as part of Spermaceae s. str., we suggest that the difference between the MP and BI analysis could be the result of data sampling artifacts (only *rps16* was sequenced for *N. arborea*), which probably affected the BI more than the MP analysis.

With the deeper nodes unresolved or only weakly supported, the relationships within Spermaceae s. str. remain unclear and should be the subject of further phylogenetic studies including more taxa and/or characters. Nevertheless, our analyses corroborate

Table 2. Characteristics of each data matrix and the corresponding tree statistics.

	No. of taxa	No. of char.	No. of PI char.	No. of PI indels	No. of MPT	MPT length	CI	RI
<i>atpB-rbcL</i>	100	1237	175	31	1949	399	0.55	0.84
<i>rps16</i>	105	705	191	20	1351	525	0.56	0.82
<i>trnL-trnF</i>	107	1053	184	29	343	423	0.62	0.88
Combined	128	2995	550	80	4782	1385	0.56	0.84

Char, characters; CI, consistency index (Kluge & Farris, 1969); MPT, most parsimonious tree(s); PI, potentially informative; RI, retention index (Farris, 1989).

the monophyly of most of the commonly accepted genera within Spermaceae s. str., notably *Crusea* Cham. & Schltdl., *Mitracarpus* Zucc. ex Schult. & Schult. f., and *Richardia* L., although these were sampled only with a few species. In contrast, the two *Galianthe* Griseb. sampled species are paraphyletic to *Diodia spicata* Miq., a species that was recently excluded from *Diodia* s. str. and transferred to *Borreria*. If the position of *D. spicata* is confirmed by further phylogenetic studies, the generic circumscription of *Galianthe* should be widened to include at least this species. Dessein (2003) already showed that palynological data (7-zonocolporate pollen, long ectocolpi, double reticulum) support a close relation between *D. spicata* and *Galianthe*. *Diodia* L. as traditionally delimited, including species referred to *Diodella* Small by Bacigalupo and Cabral (1999), is not supported as monophyletic. Also, *Spermaceae* s.l., including *Borreria*, is not supported as monophyletic.

BOU VARDIA AND MANETTIA

Manettia is strongly supported as monophyletic (JS = 100, BS = 100, PP = 1), whereas support for *Bouvardia* is moderate (JS = 85, BS = 87, PP = 0.99). In accordance with Andersson et al. (2002), *Arcytophyllum serpyllaceum* is corroborated as sister to *Bouvardia*. This strongly supported relationship (JS = 99, BS = 99, PP = 1), in combination with the fact that the remaining *Arcytophyllum* species are strongly supported as a monophyletic and distinct lineage (see below), suggests that at least *A. serpyllaceum* should be included within *Bouvardia*. Although *Bouvardia* is generally considered as a genus of shrubs only, it comprises both subshrubs and perennial herbs (Blackwell, 1968), which makes it possible to fit in *A. serpyllaceum*. *Arcytophyllum serpyllaceum* is similar to *Bouvardia* and different from other *Arcytophyllum* species in many respects. First, the stipule margin of *A. serpyllaceum* is not dentate or fimbriate, as in most *Arcytophyllum* species (Mena, 1990), but consists of a basal sheath and a trullate mucro as in most *Bouvardia* species (Blackwell, 1968). Second, where-

as the seeds of *Arcytophyllum* are more or less cymbiform (Mena, 1990), those of *A. serpyllaceum* are discoid with a central hilum as in *Bouvardia* (Andersson et al., 2002). The major difference between seeds of *A. serpyllaceum* and *Bouvardia* is that *Bouvardia* seeds are winged, whereas those of *A. serpyllaceum* are not.

ARCYTOPHYLLUM HOUSTONIA CLADE

Previous studies based on plastid DNA sequences have shown *Arcytophyllum* to be monophyletic and closely related to the North American *Houstonia* (Andersson & Rova, 1999; Andersson et al., 2002). Our analyses support the monophyly of the Neotropical genus *Arcytophyllum* (JS = 93, BS = 92, PP = 1) only if *A. serpyllaceum* is excluded from the genus (see above). Sister to *Arcytophyllum* is a group of North and Central American species presently classified in the genera *Houstonia*, *Oldenlandia*, and *Stenaria*. By having its closest relatives in North America rather than in South America, *Arcytophyllum* may be one of the few examples within Rubiaceae that has reached the Andes by a southern migration (Andersson et al., 2002). From this perspective, Mesoamerican species like *O. microtheca* (Cham. & Schltdl.) DC. may represent remnants of stepping-stone populations.

The *Arcytophyllum*–*Houstonia* clade as defined by our results is thus restricted to the New World. Seeds of *Arcytophyllum* and *Houstonia* are generally more or less cymbiform. Our results thus support Schumann's (1891) grouping of genera with cymbiform seeds. So far, *Neanotis* W. H. Lewis has not been sequenced, but if seed shape is indeed a good phylogenetic marker, *Neanotis* could be the closest non-American relative of the *Arcytophyllum*–*Houstonia* clade (Lewis, 1966).

There has been much discussion about the recognition of *Houstonia* at the generic level. In a recent molecular study based on ITS and *trnL* intron data (Church, 2003), *Houstonia* appeared to be paraphyletic with respect to the North American genus *Stenaria*. Therefore, Church (2003) suggested that *Houstonia* and *Stenaria* are better treated as a single genus. As currently circumscribed (Terrell, 1996), the genus *Houstonia* is composed of 20 species

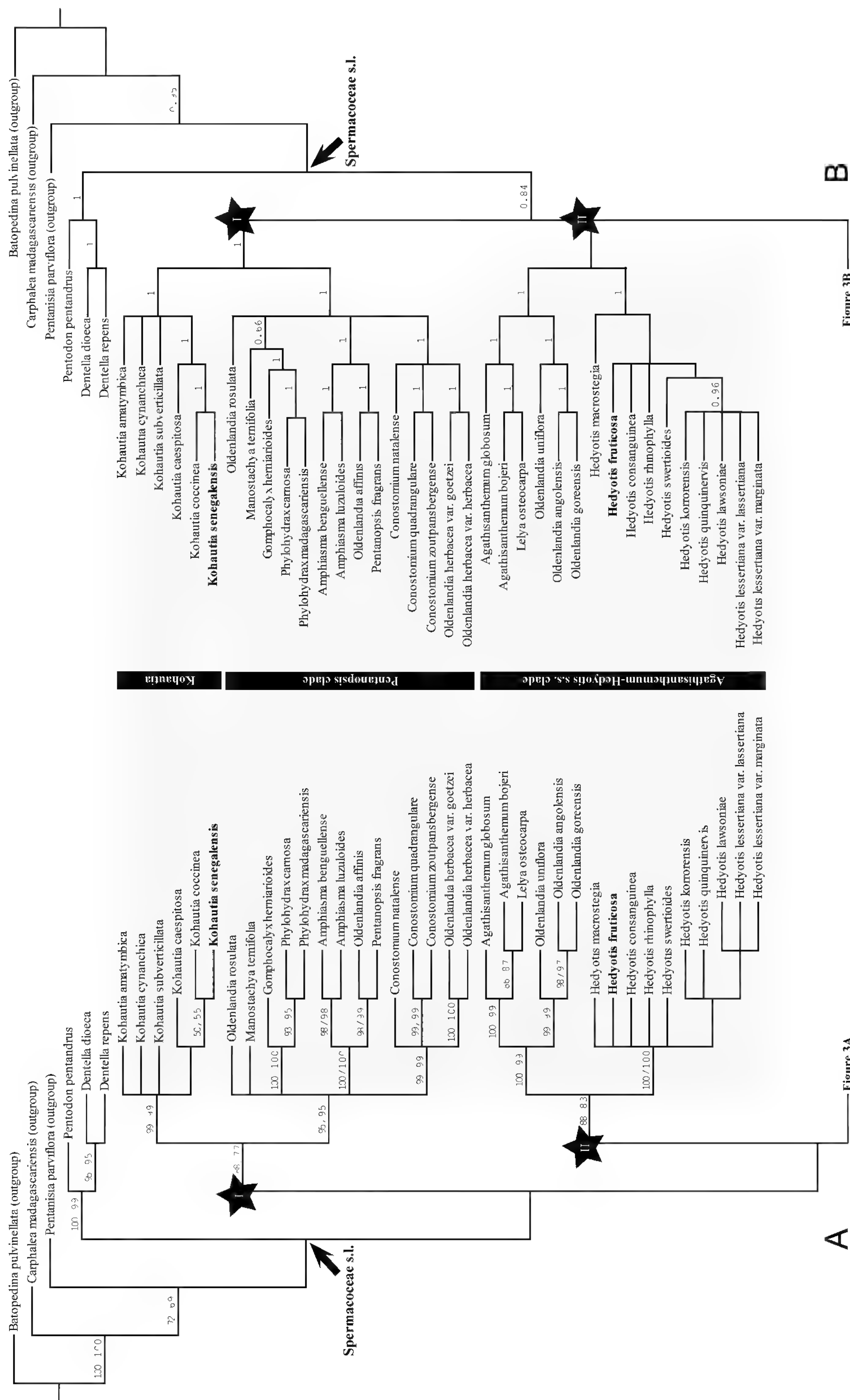

Figure 2. —A. Part one of the strict consensus tree of the 4782 MPTs from the combined analysis including *atpB-rbcL*, *rps16*, and *trnL-trnF* sequences (L = 1385, consistency index [CI] = 0.56, retention index [RI] = 0.84). Jackknife (left) and bootstrap (right) values (≥ 50) are indicated above branches. —B. Part one of the Bayesian tree based on combined *atpB-rbcL*, *rps16*, and *trnL-trnF* data. Posterior probabilities are indicated above branches. The tribe Spermaceae s.l. starts on Figure 2 (as indicated by an arrow) and continues over to Figures 3 and 4. Stars with Roman numerals I to III are assigned to the three reasonably supported clades within Spermaceae s.l.

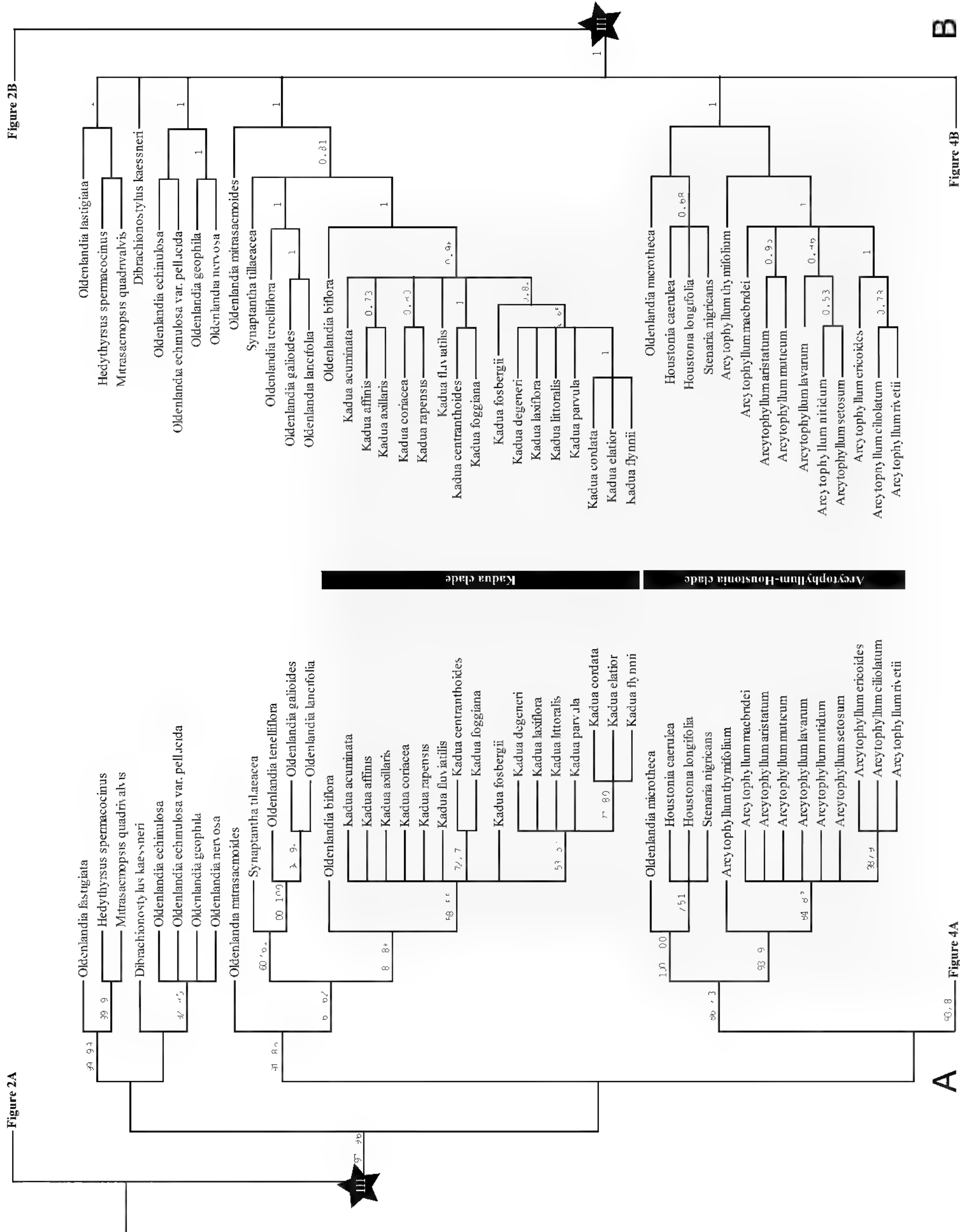

Figure 3. —A. Part two of the strict consensus tree of the 4782 MPTs from the combined analysis including *atpB-rbcL*, *rps16*, and *trnL-trnF* sequences (L = 1385, CI = 0.56, RI = 0.84). Jackknife (left) and bootstrap (right) values (≥ 50) are indicated above branches. Roman numeral III is assigned to the deeper internal node with reasonable support. The tribe Spermaceae s.l. starts on Figure 2 and continues over to Figures 3 and 4. Stars with Roman numerals I to III are assigned to the three reasonably supported clades within Spermaceae s.l.

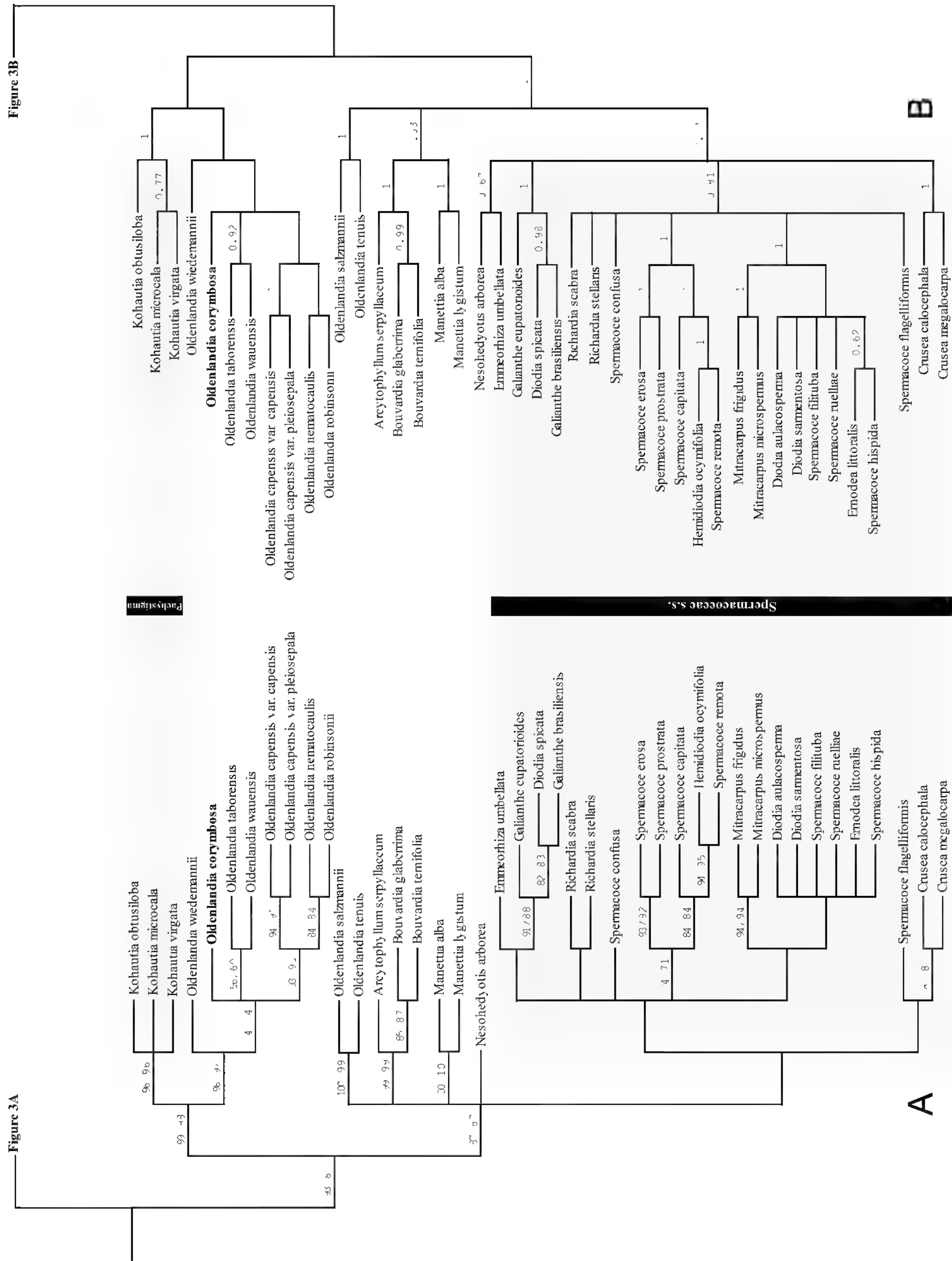

Figure 4. —A. Part three of the strict consensus tree of the 4782 MPTs from the combined analysis including *atpB-rbcL*, *rps16*, and *trnL-trnF* sequences (L = 1385, CI = 0.56, RI = 0.84). Jackknife (left) and bootstrap (right) values (> 50) are indicated above branches. —B. Part three of the Bayesian tree based on combined *atpB-rbcL*, *rps16*, and *trnL-trnF* data. Posterior probabilities are indicated above branches. The tribe Spermaceae s.l. starts on Figure 2 and continues over to Figures 3 and 4. Representatives of the former tribe Spermaceae s. str. are shown in this portion of the strict consensus tree and the Bayesian tree.

Table 3. Major morphological differences between Knoxieae and Spermaceae s.l.

	Knoxieae s.l.	Spermaceae s.l.
Merosity	often 5-merous or derived from the 5-merous state	often 4-merous, rarely 5-merous
Inflorescence	terminal (including pseudoaxillary)	terminal or axillary
Calyx lobes	often 1 or more calyx lobes enlarged	rarely enlarged calyx lobes
Pollen	bireticulum not yet reported	bireticulum common, often associated with heterostyly
Exotesta	ITW often slightly thickened	ITW without thickenings
Distribution	paleotropical, centered in Madagascar and continental Africa	pantropical, with a few taxa reaching outside the tropics

ITW, inner tangential wall.

restricted to North America. The genus contains both annual and perennial herbs with either heterostylous or homostylous flowers, crateriform seeds, and colpate pollen. Chromosome numbers are variable among species of the genus with $x = 6, 7, 8,$ or 11 . *Stenaria*, a genus only recently described (Terrell, 2001a), includes five species previously included in the North American *Hedyotis*. The genus contains only perennial, heterostylous herbs. Due to our incomplete sampling of these two genera, and given that *Houstonia* forms a polytomy with *Stenaria*, our results are not conclusive with respect to whether it is best to recognize *Stenaria* or consider it part of a more broadly delimited *Houstonia*. A more extensive sampling should focus further on this question.

Sister to the *Houstonia*–*Stenaria* clade is *Oldenlandia microtheca*. The prevailing basic chromosome number in *Oldenlandia* is $n = 9$, which occurs in the type species *O. corymbosa* and in many of the species native to North America, Asia, Africa, and Australia (Lewis, 1965), but not in *O. microtheca*, which is exceptional in having a chromosome number $n = 11$. The same chromosome number is found in *Oldenlandiopsis* Terrell & W. H. Lewis (Terrell, 1991), not included in this study, and in some *Houstonia* species (e.g., *H. rubra* Cav.). Until now, *Oldenlandia microtheca* and *Oldenlandiopsis* were never considered to be closely related to *Houstonia* because of the lack of morphological similarities (Lewis, 1965; Terrell, 1991).

Oldenlandiopsis contains only one species, *O. callitrichoides* (Griseb.) Terrell & W. H. Lewis, previously included in *Oldenlandia*. This small-leaved, small-flowered, creeping herb is native to the West Indies and southern Mexico. Based on its chromosome number and its distribution, a position of *Oldenlandiopsis* in the *Arcytophyllum*–*Houstonia* clade close to *Oldenlandia microtheca* seems quite likely. However, seeds of *Oldenlandiopsis* are non-crateriform and pollen are 8-colpate with a lalongate, slightly crassimarginate endoaperture (Terrell & Lewis, 1990). These types of seeds and pollen

are unusual within the *Arcytophyllum*–*Houstonia* clade. Plurizonocolpate pollen grains are also exceptional within the rest of the *Hedyotis*–*Oldenlandia* group, where the aperture number rarely exceeds five. The Asian genus *Neanotis* (Lewis, 1966), the Malagasy endemic *Gomphocalyx* (Dessein et al., 2005a), the Afro-Madagascan *Phylohydrax* (Puff, 1986), and the West Indian monotypic genus *Lucya* DC. (Terrell & Lewis, 1990) are notable exceptions within the *Hedyotis*–*Oldenlandia* group in having plurizonocolpate pollen grains. Both *Gomphocalyx* and *Phylohydrax* belong to the *Pentanopsis* clade (see below). With no molecular sequence data available for *Lucya*, *Neanotis*, and *Oldenlandiopsis*, it would be premature to hypothesize a close relationship between any of these taxa and the *Arcytophyllum*–*Houstonia* clade or the *Pentanopsis* clade. Nevertheless, considering their distribution, the Caribbean-Mexican genera *Lucya* and *Oldenlandiopsis* are more likely to fall in the *Arcytophyllum*–*Houstonia* clade, whereas the Asian genus *Neanotis* is more likely to have its closest relatives within the *Pentanopsis* clade.

Two closely related genera from Baja California, *Stenotis* Terrell (Terrell, 2001b) and *Carterella* Terrell (Terrell, 1987), may also belong to the *Arcytophyllum*–*Houstonia* clade. Like the Mesoamerican species *Oldenlandia microtheca*, they may represent remnants of stepping-stone populations. The monospecific genus *Carterella* was described based on *Bouvardia alexandrae* A. M. Carter. It resembles *Bouvardia* in having unusually long corolla tubes, but differs from *Bouvardia* in having wingless seeds and chromosome number $n = 13$. The genus *Stenotis*, on the other hand, includes seven former *Hedyotis* species endemic to the Baja California peninsula (Terrell, 2001b). These heterostylous, annual or perennial herbs also have chromosome number $x = 13$. According to Terrell (1987, 2001b), *Carterella* and *Stenotis* have their closest relatives among the Baja California species of *Houstonia* (*H. mucronata* group sensu Terrell et al., 1986).

KADUA

Our results support the resurrection of the genus *Kadua* for the Polynesian Hedyotideae (Hawaiian Islands and French Polynesia: Terrell et al., 2005). This taxonomic change was previously suggested by unpublished molecular data (Motley et al., 1998; Motley, 2003) and by morphological studies of the seed anatomy of the Hawaiian species (Terrell et al., 2005). The genus *Kadua* was treated as a distinct genus until Fosberg's (1943) revision of the group. He included the genus within a broadly delimited *Hedyotis*, except for the fleshy-fruited species, which he treated as *Gouldia* A. Gray (Fosberg, 1937). *Kadua* species can, however, easily be distinguished from other *Hedyotis* species by their salverform, fleshy corollas with appendaged lobes, and by their either tardy, often incomplete septicidal dehiscent capsules or indehiscent drupaceous fruits (Terrell et al., 2005). The genus *Kadua* currently comprises 28 species; all are indigenous to the Pacific Islands with the majority (21 species) occurring on the Hawaiian Islands (Terrell et al., 2005). Seeds of these Hawaiian *Kadua* species fall into four groups, described by Terrell et al. (2005). Based on the chloroplast data alone, the relationships within the genus *Kadua* remain mostly unresolved. Only section *Wiegmannia* Meyen, W. L. Wagner & Lorence (represented in our sampling by *K. cordata* Cham. & Schltdl., *K. degeneri* (Fosberg) W. L. Wagner & Lorence, *K. elatior* (H. Mann) W. L. Wagner & Lorence, *K. flynnii* (W. L. Wagner & Lorence) W. L. Wagner & Lorence, *K. laxiflora* H. Mann, *K. littoralis* Hillebr., and *K. parvula* A. Gray) and section *Gouldiopsis* (Fosberg) W. L. Wagner & Lorence (represented in our sampling by *Kadua centranthoides* Hook. & Arn. and *K. foggiana* (Fosberg) W. L. Wagner & Lorence) were recovered. A broader sampling including more *Kadua* species and more molecular markers is needed to discuss molecular evolution in the light of the seed morphological observations of Terrell et al. (2005).

Oldenlandia biflora is sister to the *Kadua* clade. Its distribution from (sub)tropical Asia to the western Pacific is consistent with the sister relationship to the Polynesian *Kadua* clade. Our results show that *O. biflora* can no longer be included within the genus *Oldenlandia*, but it is necessary to await further studies before transferring it to *Kadua* or describing a new genus. So far, we have not found morphological characters to support the transfer.

HEDYOTIS S. STR.

It seems appropriate to restrict the name *Hedyotis* to the Asian and Micronesian species of the genus,

which includes the type species *H. fruticosa* (Sri Lanka). Several authors already considered the genus *Hedyotis* to be a distinct Asian taxon (Bremekamp, 1952; Hallé, 1966; Terrell, 1975, 1991; Andersson et al., 1999). *Hedyotis fruticosa* and its Asian relatives are not closely related to the American species of *Hedyotis* (*Houstonia* lineage) or to the Polynesian species (*Kadua*). The Asian and Micronesian *Hedyotis* species (*Hedyotis* s. str.) differ from the American and Polynesian ones in their combination of a robust (sometimes shrubby) habit, small beaked and diplophragmous capsules, dorsiventrally compressed seeds with the hilum on a conspicuous central ridge (Terrell & Robinson, 2003), and a high chromosome number (Kiehn, 1986). Our results clearly demonstrate that a broad concept of *Hedyotis*, merging several genera (*Hedyotis* s. str., *Houstonia*, *Kadua*, *Kohautia*, *Oldenlandia*, etc.), as was proposed by several researchers (Fosberg, 1943; Merrill & Metcalf, 1946; Rogers, 1987; Wagner et al., 1989; Fosberg & Sachet, 1991; Dutta & Deb, 2004), is no longer supported. If this is confirmed with further sampling, all North American species now called *Hedyotis* would require new combinations under other generic names.

Pleiocraterium Bremek. (not included in this study) is probably related to the *Hedyotis* s. str. clade. The genus was described by Bremekamp in 1939, including four species distributed in India, Sri Lanka, and Sumatra. The generic name refers to the numerous cups that are formed by the connate leaf bases. The type species of the genus, *P. verticillare* (Wall. ex Wight & Arn.) Bremek., was previously included in *Hedyotis*. However, the genus differs from other *Hedyotis* s. str. species in having distinctly beaked capsules and parallel-nerved, quaternate leaves. The internodes remain very short, as a result of which the leaf whorls are clustered in rosettes. It will be necessary to wait, however, until molecular data of *Pleiocraterium* become available before a close relation of the genus to the Asian *Hedyotis* species is confirmed.

AGATHISANTHEMUM CLADE (CLADE II)

The African genus *Agathisanthemum* is not supported as monophyletic by our analyses. The monotypic African genus *Lelya* Bremek. is nested within *Agathisanthemum*, making it paraphyletic as currently circumscribed and suggesting that *Lelya* should be reduced to *Agathisanthemum*. This proposal is supported by several palynological characters. Scheltens (1998) showed that *Agathisanthemum* and *Lelya* share the same pollen type, characterized by a distinct endocolpus or endocingulum, a mesoporus surrounded by a costa at the inside of the grain (described as a compound ora by Lewis, 1965), and a microreticulate

sexine with granules on the muri facing the lumina (bireticulum).

A group of African *Oldenlandia* species is sister to *Agathisanthemum*. Two of the three *Oldenlandia* species, *O. angolensis* and *O. goreensis*, belong to *Oldenlandia* subg. *Anotidopsis* (Hook. f.) K. Schum. This subgenus, as described by Bremekamp (1952), includes three other putative species of which only *O. cephalotes* (Hochst.) Kuntze (not included in our sampling) is currently recognized. Subgenus *Anotidopsis* is distributed in Asia, Australia, and Africa and is characterized by distinctly beaked capsules. The New World taxon *O. uniflora* is sister to *O. angolensis* and *O. goreensis*. More detailed (molecular as well as morphological) studies within the *Agathisanthemum* clade are needed to evaluate if the three *Oldenlandia* species, *O. angolensis*, *O. goreensis*, and *O. uniflora*, or the entire *Oldenlandia* subg. *Anotidopsis*, are to be transferred to a new genus or if these species are better treated as members of the genus *Agathisanthemum*.

The Asian *Hedyotis* species are sister to the *Agathisanthemum*–*Oldenlandia* clade. This relationship is not unexpected as Bremekamp (1952) already suggested a close relationship between *Agathisanthemum* and the Asian *Hedyotis* species (i.e., *Hedyotis* sect. *Diplophragma*) based on a similar type of dehiscence of the capsules.

PENTANOPSIS CLADE

Our sampling resulted in a broader concept of the *Pentanopsis* clade than proposed by Thulin and Bremer (2004). They included *Amphasma*, *Conostomium* (Stapf) Cufod., *Manostachya* Bremek., *Pentanopsis*, and *Phylohydrax*.

Oldenlandia affinis was not included in the study of Thulin and Bremer (2004), but it was shown to be closely related to the African genus *Amphasma* by Andersson and Rova (1999) and Dessein et al. (2005a). *Amphasma*, *O. affinis*, and *Pentanopsis* share sessile linear leaves, indistinctly beaked capsules, non-mucilaginous seeds and nonpunctate testa cells (Bremekamp, 1952). However, a detailed study is needed to find more unambiguous morphological characters to support a relation among the three taxa.

In the past, *Gomphocalyx* (a monospecific genus endemic to Madagascar) and *Phylohydrax* (a genus described in 1986 by Puff to accommodate the East African and Madagascan *Hydrophylax* L. f. species) were both included in Spermaceae s. str. based on their uniovulate ovaries and plurizonocolporate pollen grains (Robbrecht, 1988). However, recent molecular studies excluded both genera from Spermaceae s. str. and suggested that they are closely related to one another and to the *Pentanopsis* clade (Dessein, 2003;

Thulin & Bremer, 2004; Dessein et al., 2005a). The close relationship between *Gomphocalyx* and *Phylohydrax* is supported by our results and by several morphological characters (amphistomatic leaves, plurizonocolporate pollen, indehiscent fruits, and seeds with a weak, pale exotesta) as shown by Dessein et al. (2005a). Almost all taxa in the *Hedyotis*–*Oldenlandia* group have multiovulate ovaries, and the number of pollen apertures rarely exceeds five. The presence of uniovulate ovaries and plurizonocolporate pollen were the main reasons why *Gomphocalyx* and *Phylohydrax* were previously included in Spermaceae s. str., where it is more common than in the rest of the Spermaceae s.l. tribe, in which 3-colporate pollen predominates (Dessein et al., 2002, 2005b; Dessein, 2003). As mentioned above, the Asian genus *Neanotis* is a notable exception in having plurizonocolporate pollen grains. The genus also shows a trend toward reduction in the number of seeds per locule. In mature fruits, only one or two seeds are present. However, with no molecular sequence data available for the genus it would be premature to hypothesize a close relationship between *Neanotis*, *Gomphocalyx*, and *Phylohydrax*. A few authors (Capuron, 1973; Pieschaert, 2001) also proposed a close relationship between *Gomphocalyx* and *Lathraeocarpa* Bremek., another endemic to Madagascar. Although *Lathraeocarpa* is not a trailing herb like *Gomphocalyx* but a (sub)shrub, the two taxa share a calyx with eight lobes, uniovulate ovaries, and plurizonocolporate pollen. The last two characters also support a close relationship between *Phylohydrax* and *Lathraeocarpa*. However, several morphological characters distinguish *Lathraeocarpa* from *Gomphocalyx*, some of which might even point to an affinity with *Triainolepis* Hook. f. First, the (sub)shrubby habit of *Lathraeocarpa* is much more similar to the shrubby habit of *Triainolepis* than to the herbaceous habit of *Gomphocalyx*. Second, the pyrene of *L. decaryi* Bremek. is surrounded by eight strands of thin-walled cells, a condition very similar to that observed in some *Triainolepis* species (Bremekamp, 1957; Pieschaert, 2001). Likewise, *Lathraeocarpa* and *Triainolepis* have a plurilocular ovary and fleshy fruits, whereas *Gomphocalyx* has a bilocular ovary and dry fruits, which has prompted some authors (Kårehed & Bremer, 2007) to tentatively include *Lathraeocarpa* in the emended tribe Knoxiaceae rather than in Spermaceae s.l. However, we will have to wait until molecular data become available to assess the taxonomic position of *Lathraeocarpa* with more certainty (Dessein et al., 2005a).

Species of *Conostomium* form a strongly supported clade (JS – 99, BS – 99, PP – 1) together with *Oldenlandia herbacea*. The type of the genus *Conostomium*, *C. natalense* (Hochst.) Bremek., is unre-

solved with respect to the other species of *Conostomium* and to *O. herbacea*. Both *Conostomium* and *O. herbacea* have seeds with coarsely granulate testa cells (Bremekamp, 1952; Desein, 2003) and pollen that is larger than that of most other genera within the *Hedyotis–Oldenlandia* group (Bremekamp, 1952; Scheltens, 1998). These characters, however, are homoplasious because granulate testa cells and large pollen grains also occur elsewhere in the *Hedyotis–Oldenlandia* group. We observed granulate testa cells in *Kohautia* subg. *Pachystigma*, *O. corymbosa*, and *O. nematocaulis* Bremek., whereas large pollen grains are characteristic of *Amphiasma*, *Gomphocalyx*, and *Phylohydrax*. The most striking feature of *Conostomium* pollen, namely the short ectocolpi (Scheltens, 1998; Desein et al., 2005a), is not found in *O. herbacea* or in most other members of the *Pentanopsis* clade, but it is reported for *Gomphocalyx* and *Phylohydrax* (Desein et al., 2005a).

The last additional species falling in the *Pentanopsis* clade is *Oldenlandia rosulata*, an African species named after its basal rosulate leaves. The relationship of *O. rosulata* to other members of the *Pentanopsis* clade remains unclear.

Despite the strong support for the *Pentanopsis* clade (JS – 95, BS – 95, PP – 1) in our molecular analyses, the group is not easily morphologically characterized. The only unifying feature for the clade would be what Thulin and Bremer (2004) called basal placentation. Nevertheless, the placentation is not truly basal, but rather axile with the placenta or ovule attached near the base of the septum. Our observations show that this kind of placentation is also found outside the *Pentanopsis* clade. Moreover, the basal placentation character state is only vaguely defined, and more detailed placentation studies within Spermaceae s.l. are needed before further conclusions can be drawn about the phylogenetic value of this character.

MONOSPECIFIC GENERA WITHIN THE *HEDYOTIS* *OLDENLANDIA* GROUP

Besides the genus *Gomphocalyx* of the *Pentanopsis* clade, the *Hedyotis–Oldenlandia* group comprises several other monospecific genera. These monospecific genera often have several peculiar characters, making it very difficult to discuss their relationship with other Spermaceae.

In our sampling, for example, the Afro-Madagascan genus *Mitrasacmopsis* has seeds with undulating radial exotesta cell walls, distinctly stalked placentas with ovules positioned on the periphery of the placental tissue, pollen grains with a double reticulum, and fruits with a conspicuous beak (Groeninckx et al., 2007). Our molecular results suggest a close

relationship of this monospecific genus to *Hedythyrus* and *Oldenlandia fastigiata*. Our own observations have identified similar placentation types within these taxa. Moreover, *Hedythyrus* and *Mitrasacmopsis* have the same type of capsule dehiscence (loculicidal followed by septicidal dehiscence), seeds with testa cells that show the same undulating radial walls, and pollen with a double reticulum (Groeninckx, 2005).

The monospecific genus *Dibrachionostylus* is sister to a clade of African *Oldenlandia* species. The genus was separated from *Oldenlandia* largely on the basis of its capsule dehiscence (both loculicidal and septicidal vs. only loculicidal in *Oldenlandia*). Bremekamp (1952) closely associated *Dibrachionostylus* with *Agathisanthemum* because of their similar fruit dehiscence. However, *Dibrachionostylus* differs markedly from *Agathisanthemum* in the pollen aperture morphology (Lewis, 1965). As mentioned above, *Agathisanthemum* has a distinct ectocolpus, an endocolpus or endocingulum, and a mesoporus surrounded by a costa at the inside of the grain (Lewis, 1965). Pollen grains of *Dibrachionostylus* are also 3-colporate but do not have a costa on the inside (Lewis, 1965). The apertures of *Dibrachionostylus* pollen are, therefore, more similar to those of *Amphiasma*, *Oldenlandia*, and *Pentodon* (Lewis, 1965).

Nesohedyotis is another monospecific genus previously included in the Hedyotideae. Its only species, *N. arborea*, shows a superficial resemblance to the East African genus *Hedythyrus*; specimens of both taxa turn black when dried, and their leaf shape and inflorescence structure are similar (Bremekamp, 1952). However, our results show that *Nesohedyotis* is more closely related to the former tribes Spermaceae s. str. and Manettieae than to members of the *Hedyotis–Oldenlandia* group. *Nesohedyotis* has unisexual flowers, which are unusual among Spermaceae, and, in contrast to *Hedythyrus*, its fruits open by a single loculicidal split. Although it is one of the more common endemic species on St. Helena, its small population size and small geographical distribution make *Nesohedyotis* Endangered (EN) according to IUCN Red List criteria (IUCN, 2001).

According to Verdcourt (1976), the monospecific Tanzanian *Pseudonesohedyotis* Tennant, which is not included in our sampling, is closely related to *Nesohedyotis* and *Hedythyrus*. *Pseudonesohedyotis* has indeed the same leaf shape and inflorescence structure as the latter two taxa. In habit and distribution, however, it resembles *Hedythyrus* more than *Nesohedyotis*. Both *Pseudonesohedyotis* and *Hedythyrus* are (sub)shrubs, whereas *Nesohedyotis* is a small tree. Moreover, *Pseudonesohedyotis* differs from *Nesohedyotis* in having hermaphroditic flowers. Again, it is necessary to wait until molecular data become available to discuss the taxonomic position of *Pseudonesohedyotis* with more confidence.

Based on the presence of an apparently superior ovary, Jovet (1941) originally placed *Mitrasacmopsis* and *Astiella* Jovet, another monospecific genus of the *Hedyotis–Oldenlandia* group endemic to Madagascar (not included in this study), within Loganiaceae–Spigeliaceae. Members of Rubiaceae are generally characterized by the presence of an inferior ovary. Groeninckx et al. (2007) demonstrated that flowers of *Mitrasacmopsis* are initially epigynous with inferior ovaries. Expansion of the upper part of the ovary in fruiting stage results in a change in the ovary position of *Mitrasacmopsis* from basically inferior to secondarily semi-inferior. The same kind of fruit development also most likely occurs in *Astiella*. In her morphological study of the Rubioideae, Hayden (1968) stated that some genera of Spermaceae s. str. have semi-inferior fruits. According to Robbrecht (1988), this statement is based on the strong expansion of the top of the nectary disc in the fruiting stage. However, we have not observed semi-inferior ovaries within Spermaceae s. str. Nevertheless, within Spermaceae s.l. several other taxa, apart from *Mitrasacmopsis* and *Astiella*, are characterized by the presence of a beak at fruit stage (*Conostomium* spp., *Hedythyrus* spp., *Kohautia* spp., *Oldenlandia* spp.). These beaks are not remnants of the nectary disc and probably originate in a similar way as in *Mitrasacmopsis*. However, the ovaries of these species do not undergo a remarkable reverse in shape in the fruiting stage as observed in *Mitrasacmopsis* and *Astiella*. Based on their fruit shape, *Mitrasacmopsis* and *Astiella* seem closely related. However, Jovet (1941) also suggested a close relationship between *Astiella* and the Asian *Anotis* DC. species, presently classified in the genus *Neanotis* (Lewis, 1966). *Astiella* differs from both genera in having only two calyx lobes, a character that so far has not been observed within the *Hedyotis–Oldenlandia* group, and uniovulate locules. Molecular sequence data of *Astiella* will allow us to discover the taxonomic position of the genus in the future.

Other monospecific genera of the *Hedyotis–Oldenlandia* group are *Carterella*, *Dolichometra* K. Schum., *Lelya*, *Leptoscela* Hook. f., *Lucya*, *Phyllocrater* Wernham, *Polyura* Hook. f., *Stephanococcus* Bremek., and *Oldenlandiopsis*. The genera *Carterella*, *Lelya*, *Lucya*, and *Oldenlandiopsis* were already discussed in previous sections. To date, the taxonomic position of most of these monospecific genera remains controversial because molecular data are lacking.

KOHAUTIA

Kohautia is a genus of 31 species (Mantell, 1985) distributed from the Indian subcontinent through Pakistan, Iran, the Arabian Peninsula, Sinai, eastern

Egypt, and throughout most of Africa south of the Sahara (including Socotra, Cape Verde, and Madagascar). The genus can easily be distinguished from other representatives of the *Hedyotis–Oldenlandia* group by its unique flower morphology. The anthers and stigma are always included, with the stigma held well below the anthers or occasionally just touching them. This monomorphic short-styled condition is, with the exception of a few individuals of *Conostomium*, unique among the African members of the former tribe Hedyotideae. For this reason, *Kohautia* has always been considered a distinct genus (Bremekamp, 1952; Mantell, 1985). Our molecular results, however, show that the two subgenera of *Kohautia* are not sister clades. Subgenus *Kohautia* is sister to the *Pentanopsis* clade, whereas subgenus *Pachystigma* is sister to an *Oldenlandia* clade containing the type species *O. corymbosa*.

Despite the unifying floral architecture, there are numerous morphological differences between the two subgenera (Lewis, 1965; Mantell, 1985). The number of stigmatic lobes is the most striking diagnostic character that allows identification of the subgenera even in the field. Members of subgenus *Kohautia* have styles with two thin filiform stigma lobes, whereas *Pachystigma* is characterized by the presence of only a single, ovoid to cylindrical stigma lobe. Seeds are also different in the two subgenera: subgenus *Kohautia* seeds are angular-conic to subconic in shape with 5- or 6-angled testa cells, whereas in subgenus *Pachystigma* the seeds are rounded with wavy and punctate testa cells. Pollen of *Kohautia* can also be divided into two easily recognizable groups coinciding with the two subgenera (Lewis, 1965). Other differences between the two subgenera are found in floral architecture and chromosome number. Based on these differences, Mantell (1985) hypothesized that the two subgenera may have diverged and developed independently of one another fairly early on and she even tentatively proposed the elevation of the two subgenera to generic rank. At that time, Mantell decided to maintain a widely defined genus *Kohautia*, mainly for practical reasons. However, our molecular data now clearly support the recognition of two genera. Sampling within the genus still needs to be improved before proposing new generic circumscriptions.

OLDENLANDIA

Govaerts et al. (2006) currently accept 76 *Oldenlandia* species from Africa, 155 from Asia and Australia, 23 from America, and eight from the Pacific Islands. However, as documented in previous molecular studies (Bremer, 1996; Andersson & Rova, 1999;

Bremer & Manen, 2000), *Oldenlandia* is shown to be polyphyletic.

Bremekamp (1952) divided the 61 species that he recognized from Africa into 16 subgenera. Our results do not support the majority of these subgenera. Only the subgenus *Hymenophyllum* Bremek. (*Oldenlandia echinulosa* and *O. nervosa*) and subgenus *Anotidopsis* (*O. angolensis* and *O. goreensis*) are corroborated.

The type species, *Oldenlandia corymbosa*, is sister to a clade with the African species *O. capensis* L. f., *O. robinsonii* Pit., *O. nematocaulis*, *O. taborensis* Bremek., and *O. wauensis* Schweinf. ex Hiern. The last species, *O. wauensis*, was segregated by Bremekamp (1952) in a new genus *Thecorchus* Bremek., which he proposed to be allied with *Otomeria* of the tribe Knoxieae because of its distinctly elongated capsules and equal number of tetramerous and pentamerous flowers. However, Kårehed and Bremer (2007) showed that *Thecorchus* is not related to *Otomeria* but is close to *Oldenlandia*. Our results, which place *Thecorchus* in a clade comprised of the type species of *Oldenlandia*, support the transfer of *T. wauensis* (Schweinf. ex Hiern) Bremek. back into *Oldenlandia*. The type species *O. corymbosa* and *O. capensis* belong to Bremekamp's (1952) subgenus *Oldenlandia* K. Schum. Besides these two species, subgenus *Oldenlandia* also includes *O. fastigiata* and *O. herbacea*. These species are apparently not related to *O. corymbosa* and its allies. *Oldenlandia fastigiata* is sister to *Hedythyrus* and *Mitrasacmopsis*, whereas *O. herbacea* in the *Pentanopsis* clade is sister to a paraphyletic *Conostomium*. Bremekamp (1952) already pointed out that *O. herbacea* differs from the rest of the subgenus by the coarsely granulated walls of the testa cells, the rather large flowers, and the slender corolla tube.

The Australian species of *Oldenlandia*, *O. mitrasacmoides* and *O. galioides*, sampled here belong to a clade comprising the Australian *Synaptantha tillaeacea*, the Austro-Asian *O. tenelliflora*, the African species *O. lancifolia*, and the *Kadua* species (including *O. biflora*). *Oldenlandia mitrasacmoides* is sister to the rest of the clade. *Synaptantha tillaeacea* is sister to a clade with *Oldenlandia tenelliflora*, *O. galioides*, and *O. lancifolia*. *Synaptantha* Hook. f. may be distinguished from the other genera in the clade by its slightly connate corolla lobes, stamens with filaments attached to both the corolla and the ovary, depressed obconic or ovoid seeds, and half-inferior ovaries (Halford, 1992). In his review of Australian *Oldenlandia*, Halford (1992) distinguished five groups mostly based on seed morphology. *Oldenlandia galioides* and *O. tenelliflora* are placed together in his group one, which is characterized by obconic seeds that are slightly laterally compressed and

obtriangular in outline. *Oldenlandia mitrasacmoides* belongs to his group two, which is characterized by scutelliform seeds that are oblong or broadly elliptic in outline, with the hilum situated on a conspicuous central ridge. The African species *O. lancifolia* has seeds similar in shape to those of its sister *O. galioides* (Dessein, 1998).

Not all American *Oldenlandia* species included in our sampling are placed within the *Arcytophyllum–Houstonia* clade (see discussion above). The remaining South American species of *Oldenlandia*, *O. salzmännii* and *O. tenuis*, form a clade sister to the former tribes Spermaceae s. str. and Manettieae. Terrell (1990) already reported that *O. salzmännii* is clearly distinct from *Houstonia* and *Oldenlandia*. In contrast to other *Oldenlandia* species, *O. salzmännii* does not have the typical oldenlandioid seeds or base number of chromosomes ($n = 15$ instead of 9). Moreover, it shares some unusual characters with *Oldenlandiopsis*: stipules are minute, not more than 0.5 mm long (*Oldenlandia* stipules are often 2–3 mm long); few stiff hairs occur on the leaves (*Oldenlandia* species usually have smaller, softer hairs); and it has a creeping habit (which is rare in *Oldenlandia*, the usual habit being erect to spreading or prostrate). It would be very informative to include *Oldenlandiopsis* in future studies to investigate its relationship to either *O. microtheca* (see discussion of the *Arcytophyllum–Houstonia* clade above) or *O. salzmännii*.

FUTURE RESEARCH PLANS AND CONCLUSIONS

Although our analyses found well-supported clades within Spermaceae s.l., many relationships within and between these clades still remain unresolved. Furthermore, many relationships detected here are contradictory to previous taxonomic treatments and await morphological backup. This study was a multi-partner collaboration resulting in a framework for future Spermaceae research. Further studies will focus on obtaining additional DNA markers (i.e., nuclear DNA data) to provide better resolution within the tribe. Besides improving the character sampling, we also need to balance the taxon sampling by including more Asian and American taxa. In addition, concerted studies will focus on the morphological characterization of monophyletic groups within Spermaceae. This requires a morphological investigation across taxa to find character support for the many new phylogenetic relationships detected.

Literature Cited

- Andersson, L. & J. H. E. Rova. 1999. The *rps16* intron and the phylogeny of the Rubioideae (Rubiaceae). *Pl. Syst. Evol.* 214: 161–186.

- & F. G. Alzate. 2002. Relationships, circumscription, and biogeography of *Arcytophyllum* (Rubiaceae) based on evidence from cpDNA. *Brittonia* 54: 40–49.
- Bacigalupo, N. & E. Cabral. 1999. Revisión de las especies americanas del género *Diodia* (Rubiaceae, Spermaceae). *Darwiniana* 37: 15–165.
- Blackwell, W. H. Jr. 1968. Revision of *Bouvardia* (Rubiaceae). *Ann. Missouri Bot. Gard.* 55: 1–30.
- Bremekamp, C. E. B. 1934. Notes on the Rubiaceae of Surinam. *Recueil Trav. Bot. Neerl.* 31: 248–308.
- . 1939. *Pleiocraterium* genus novum Rubiacearum Hedyotidearum. *Recueil Trav. Bot. Neerl.* 36: 438–445.
- . 1952. The African species of *Oldenlandia* L. sensu Hiern & K. Schumann. *Verh. Kon. Ned. Akad. Wetensch. Afd. Natuurk.* 48: 1–197.
- . 1957. Les Lathraeocarpeés, tribu nouvelle des Rubioïdées (Rubiaceae). *Bull. Jard. Bot. État Bruxelles* 27: 159–166.
- . 1966. Remarks on the position, the delimitation and subdivision of the Rubiaceae. *Acta Bot. Neerl.* 15: 1–33.
- & J. F. Manen. 2000. Phylogeny and classification of the subfamily Rubioideae (Rubiaceae). *Pl. Syst. Evol.* 225: 43–72.
- Bremer, B. 1996. Phylogenetic studies within the Rubiaceae and relationships to other families based on molecular data. *Opera Bot. Belg.* 7: 33–50.
- Cabral, E. L. 1991. Rehabilitación del género *Galianthe* (Rubiaceae). *Bol. Soc. Argent. Bot.* 27: 234–249.
- Capuron, R. 1973. Révision des Rubiacées de Madagascar et des Comores. Unpublished manuscript. Notes regroupées et mises en forme par J. Bosser, dactylographiées de F. Chauvet. Laboratoire de Phanérogamie, Paris.
- Church, S. A. 2003. Molecular phylogenetics of *Houstonia* (Rubiaceae): Descending aneuploidy and breeding system evolution in the radiation of the lineage across North America. *Molec. Phylogen. Evol.* 27: 223–238.
- Dessein, S. 1998. Fylogenie van de Hedyotideae (Rubiaceae)—Een morfologische en anatomische studie van de Afrikaanse taxa. Master's Thesis, Katholieke Universiteit Leuven, Leuven, Belgium.
- . 2003. Systematic Studies in the Spermaceae (Rubiaceae). Ph.D. Dissertation, Katholieke Universiteit Leuven, Leuven, Belgium.
- , A. Scheltens, S. Huysmans, E. Robbrecht & E. Smets. 2000. Pollen morphological survey of *Pentas* (Rubiaceae—Rubioideae) and its closest allies. *Rev. Paleobot. Palynol.* 112: 189–205.
- , S. Huysmans, E. Robbrecht & E. Smets. 2002. Pollen of African *Spermaceae* species (Rubiaceae): Morphology and evolutionary aspects. *Grana* 41: 69–89.
- , L. Andersson, K. Geuten, E. Smets & E. Robbrecht. 2005a. *Gomphocalyx* and *Phylhydrax* (Rubiaceae): Sister taxa excluded from the Spermaceae s.s., featuring a remarkable case of convergent evolution. *Taxon* 54: 91–107.
- , H. Ochoterena, P. De Block, F. Lens, E. Robbrecht, P. Schols, E. Smets, S. Vinckier & S. Huysmans. 2005b. Palynological characters and their phylogenetic signal in Rubiaceae. *Bot. Rev.* 71: 354–414.
- Dutta, R. & D. B. Deb. 2004. Taxonomic Revision of *Hedyotis* L. (Rubiaceae) in Indian Subcontinent. Botanical Survey of India, Kolkata, India.
- Farris, J. S. 1989. The retention index and the rescaled consistency index. *Cladistics* 5: 417–419.
- Fosberg, F. R. 1937. The genus *Gouldia* (Rubiaceae). *Bull. Bernice P. Bishop Mus.* 147: 1–85.
- . 1943. The Polynesian species of *Hedyotis* (Rubiaceae). *Bull. Bernice P. Bishop Mus.* 174: 1–102.
- & M. H. Sachet. 1991. Studies in Indo-Pacific Rubiaceae. *Allertonia* 6: 191–278.
- Goloboff, P. 1993. Nona Version 2.0. Program and documentation distributed by the author. Tucuman, Argentina.
- Govaerts, R., M. Ruhsam, L. Andersson, E. Robbrecht, D. Bridson, A. Davis, I. Schanzer & B. Sonké. 2006. World Checklist of Rubiaceae. The Board of Trustees of the Royal Botanic Gardens, Kew. <<http://www.kew.org/wcsp/rubiaceae/>>, accessed 11 November 2006.
- Groeninckx, I. 2005. Zoektocht naar de taxonomische positie van *Mitrasacmopsis* (Rubiaceae) op basis van moleculaire en morfologische data. Master's Thesis, Katholieke Universiteit Leuven, Leuven, Belgium.
- , A. Vrijdaghs, S. Huysmans, E. Smets & S. Dessein. 2007. Floral ontogeny of the Afro-Madagascan genus *Mitrasacmopsis* with comments on the development of superior ovaries in Rubiaceae. *Ann. Bot.* 100: 41–49.
- Halford, D. A. 1992. Review of the genus *Oldenlandia* L. (Rubiaceae) and related genera in Australia. *Austrobaileya* 3: 683–722.
- Hallé, N. 1966. Rubiacées, pt. 1. III. Hedyotidées. Pp. 75–124 in A. Aubréville (editor), *Flore du Gabon*. Mus. Hist. Nat. Paris.
- Hayden, S. M. V. 1968. Systematic Morphological Study of New World Rubiaceous Seeds: Rubioideae Sensu Bremekamp. Ph.D. Dissertation, University of St. Louis, St. Louis.
- Hooker, J. D. 1873. Ordo LXXXIV. Rubiaceae. Pp. 7–151 in G. Bentham & J. D. Hooker (editors), *Genera plantarum ad exemplaria imprimis in herbariis kewensibus servata definita*. Lovell Reeve & Co., London.
- Huelsenbeck, J. & F. Ronquist. 2001. MRBAYES: Bayesian inference of phylogenetic trees. *Bioinformatics* 17: 754–755.
- IUCN. 2001. IUCN Red List Categories and Criteria Version 3.1. Prepared by the IUCN Species Survival Commission. IUCN, Gland, Switzerland, and Cambridge, United Kingdom.
- Janssens, S., K. Geuten, Y.-M. Yuan, Y. Song, P. Küpfer & E. Smets. 2006. Phylogenetics of *Impatiens* and *Hydrocera* (Balsaminaceae) using chloroplast *atpB-rbcL* spacer sequences. *Syst. Bot.* 31: 171–180.
- Jovet, P. 1941. Aux confins des Rubiacées et des Loganiacées. *Notul. Syst. (Paris)* 10: 39–56.
- Kårehed, J. & B. Bremer. 2007. The systematics of Knoxiaceae (Rubiaceae)—Molecular data and their taxonomic consequences. *Taxon* 56: 1051–1076.
- Kiehn, M. 1986. Karyosystematic studies on Rubiaceae. *Pl. Syst. Evol.* 154: 213–223.
- Kluge, A. G. & J. S. Farris. 1969. Quantitative phyletics and the evolution of anurans. *Syst. Zool.* 18: 1–32.
- Lewis, W. H. 1965. Cytopalynological study of African Hedyotideae (Rubiaceae). *Ann. Missouri Bot. Gard.* 52: 182–211.
- . 1966. The Asian genus *Neanotis* nomen novum (*Anotis*) and allied taxa in the Americas (Rubiaceae). *Ann. Missouri Bot. Gard.* 53: 32–46.
- Maddison, D. R. & W. P. Maddison. 2001. *MacClade 4: Analysis of Phylogeny and Character Evolution*. Vers. 4.01. Sinauer Associates, Sunderland, Massachusetts.
- Manen, J. F., A. Natali & F. Ehrendorfer. 1994. Phylogeny of Rubiaceae—Rubieae inferred from the sequence of a cpDNA intergene region. *Pl. Syst. Evol.* 190: 195–211.
- Mantell, D. E. 1985. The Afro-South-west Asiatic Genus *Kohautia* Cham. & Schlecht. (Rubiaceae—Rubioideae—Hedyotideae): Morphology, Anatomy, Taxonomy, Phylogeography, and Evolution. Ph.D. Dissertation, Universität Wien, Vienna, Austria.

- Mena, V. P. 1990. A revision of the genus *Arcytophyllum* (Rubiaceae: Hedyotideae). *Mem. New York Bot. Gard.* 60: 1–26.
- Merrill, E. D. & C. Metcalf. 1946. *Hedyotis* L. versus *Oldenlandia* L. and the status of *Hedyotis lancea* Thunb. in relation to *H. consanguinea* Hance. *J. Arnold Arbor.* 23: 226–230.
- Motley, T. J. 2003. Phylogeny of Hawaiian and Pacific *Hedyotis* (Rubiaceae): Fruit evolution and the implications for conservation and genomics. Abstracts of Annual Meeting, Mobile, Alabama, Botany 2003: 88–89.
- , L. Struwe & V. A. Albert. 1998. Molecular systematics of Hawaiian *Hedyotis* (Rubiaceae). *Amer. J. Bot.* 85: 146.
- Negrón-Ortiz, V. & R. J. Hickey. 1996. The genus *Ernodea* (Rubiaceae) in the Caribbean Basin. II. Morphological analyses and systematics. *Syst. Bot.* 21: 445–458.
- Nixon, K. C. 1999. The parsimony Ratchet, a new method for rapid parsimony analysis. *Cladistics* 15: 407–414.
- . 2002. WinClada (beta). Vers. 1.00.08. Published by the author, Ithaca, New York.
- Oxelmann, B., M. Liden & D. Berglund. 1997. Chloroplast *rps16* intron phylogeny of the tribe Sileneae (Caryophyllaceae). *Pl. Syst. Evol.* 206: 393–410.
- Piesschaert, F. 2001. Carpology and Pollen Morphology of the Psychotrieae (Rubiaceae–Rubioidae). Towards a New Tribal and Generic Delimitation. Ph.D. Dissertation, Katholieke Universiteit Leuven, Leuven, Belgium.
- Posada, D. & K. A. Crandall. 1998. Modeltest: Testing the model of DNA substitution. *Bioinformatics* 14: 817–818.
- Puff, C. 1986. *Phylohydrax* (Rubiaceae–Spermaceae)—A new genus to accommodate the African and Madagascan *Hydrophyllax* species. *Pl. Syst. Evol.* 154: 343–366.
- Robbrecht, E. 1988. Tropical woody Rubiaceae. Characteristic features and progressions. *Contributions to a new subfamilial classification. Opera Bot. Belg.* 1: 1–271.
- . 1993. Supplement to the 1988 outline of the classification of the Rubiaceae Index to genera. *In* E. Robbrecht (editor), *Advances in Rubiaceae Macro-systematics. Opera Bot. Belg.* 6: 173–196.
- & J. F. Manen. 2006. The major evolutionary lineages of the coffee family (Rubiaceae, angiosperms). Combined analysis (nDNA and cpDNA) to infer the position of *Coptosapelta* and *Luculia*, and supertree construction based on *rbcL*, *rps16*, *trnL-trnF* and *atpB-rbcL* data. A new classification in two subfamilies, Cinchonoideae and Rubioideae. *Syst. Geogr. Pl.* 76: 85–146.
- Rogers, G. K. 1987. The genera of Cinchonoideae (Rubiaceae) in the southeastern United States. *J. Arnold Arbor.* 68: 137–183.
- Ronquist, F. & J. P. Huelsenbeck. 2003. MRBAYES 3: Bayesian phylogenetic inference under mixed models. *Bioinformatics* 19: 1572–1574.
- Scheltens, A. 1998. Pollenmorphologische studie van de Afrikaanse Hedyotideae (Rubiaceae). Licentiate Thesis, Katholieke Universiteit Leuven, Leuven, Belgium.
- Schumann, K. 1891. Rubiaceae. *In* A. Engler & K. Prantl (editors), *Die natürlichen Pflanzenfamilien* 4: 1–156.
- Simmons, M. P. & H. Ochoterena. 2000. Gaps as characters in sequence-based phylogenetic analyses. *Syst. Biol.* 49: 369–381.
- Staden, R., K. Beal & J. Bonfield. 1998. The Staden Package. Pp. 115–130 *in* S. Misener & S. Krawetz (editors), *Computer Methods in Molecular Biology*. The Humana Press Inc., New York.
- Suzuki, Y., G. V. Glazko & M. Nei. 2002. Over credibility of molecular phylogenies obtained by Bayesian phylogenetics. *Proc. Natl. Acad. Sci. U.S.A.* 99: 16138–16143.
- Swofford, D. 2002. PAUP*: Phylogenetic Analysis Using Parsimony (* and Other Methods), Vers. 4. Sinauer Associates, Sunderland, Massachusetts.
- Taberlet, P., G. Gielly, G. Pautou & J. Bouvet. 1991. Universal primers for amplification of three non-coding regions of chloroplast DNA. *Pl. Mol. Biol.* 17: 1105–1109.
- Terrell, E. E. 1975. Relationships of *Hedyotis fruticosa* L. to *Houstonia* L. and *Oldenlandia* L. *Phytologia* 31: 418–421.
- . 1987. *Carterella* (Rubiaceae), new genus from Baja California, Mexico. *Brittonia* 39: 248–252.
- . 1990. Synopsis of *Oldenlandia* (Rubiaceae) in the United States. *Phytologia* 68: 125–133.
- . 1991. Overview and annotated list of North American species of *Hedyotis*, *Houstonia*, *Oldenlandia* (Rubiaceae), and related genera. *Phytologia* 71: 212–243.
- . 1996. Revision of *Houstonia* (Rubiaceae–Hedyotideae). *Syst. Bot. Monogr.* 48: 1–118.
- . 2001a. Taxonomy of *Stenaria* (Rubiaceae; Hedyotideae), a new genus including *Hedyotis nigricans*. *Sida* 19: 591–614.
- . 2001b. *Stenotis* (Rubiaceae), a new segregate genus from Baja California, Mexico. *Sida* 19: 899–911.
- . 2001c. Taxonomic review of *Houstonia acerosa* and *H. palmeri*, with notes on *Hedyotis* and *Oldenlandia* (Rubiaceae). *Sida* 19: 913–922.
- & W. H. Lewis. 1990. *Oldenlandiopsis* (Rubiaceae), a new genus from the Caribbean basin, based on *Oldenlandia callitrichoides* Griseb. *Brittonia* 42: 185–190.
- & H. Robinson. 2003. Survey of Asian and Pacific species of *Hedyotis* and *Exallage* (Rubiaceae) with nomenclatural notes on *Hedyotis* types. *Taxon* 52: 775–782.
- , W. H. Lewis, H. Robinson & J. W. Nowicke. 1986. Phylogenetic implications of diverse seed types, chromosome numbers, and pollen morphology in *Houstonia* (Rubiaceae). *Amer. J. Bot.* 73: 103–115.
- , H. E. Robinson, W. L. Wagner & D. H. Lorence. 2005. Resurrection of genus *Kadua* for Hawaiian Hedyotideae (Rubiaceae), with emphasis on seed and fruit characters and notes on South Pacific species. *Syst. Bot.* 30: 818–833.
- Thompson, J. D., T. J. Gibson, F. Plewniak, F. Jeanmougin & D. G. Higgins. 1997. The ClustalX windows interface: Flexible strategies for multiple sequence alignment aided by quality analyses tools. *Nucl. Acids Res.* 25: 4876–4882.
- Thulin, M. & B. Bremer. 2004. Studies in the tribe Spermaceae (Rubiaceae–Rubioidae): The circumscriptions of *Amphiasma* and *Pentanopsis* and the affinities of *Phylohydrax*. *Pl. Syst. Evol.* 247: 233–239.
- Verdcourt, B. 1958. Remarks on the classification of the Rubiaceae. *Bull. Jard. Bot. État Bruxelles* 28: 209–281.
- . 1976. Rubiaceae (part 1). Pp. 1–414 *in* R. M. Polhill (editor), *Flora of Tropical East Africa*. Crown Agents for Overseas Governments and Administrations, London.
- Wagner, W. L., D. R. Herbst & S. H. Sohmer. 1989. Contributions to the flora of Hawaii: 2. Begoniaceae: Violaceae and the monocotyledons. *Bishop Mus. Occas. Pap.* 29: 88–130.

Appendix 1. List of taxa used in the phylogenetic analyses with voucher information (geographic origin, collector, collector number, herbarium), accession numbers, and literature citations from previously published sequences for the three plastid markers *atpB-rbcL*, *rps16* intron, and *trnL-trnF*: ⁽¹⁾ Andersson & Rova, 1999; ⁽²⁾ Andersson et al., 2002; ⁽³⁾ Dessein et al., 2005a. New sequences are marked with an asterisk. Missing sequences are marked with a dash.

Taxon	Voucher information	<i>atpB-rbcL</i>	<i>rps16</i> intron	<i>trnL-trnF</i>
Agathisanthemum Klotzsch				
<i>A. bojeri</i> Klotzsch	Zambia, Dessein et al. 671 (BR)	EU542917*	EU543018*	EU543077*
<i>A. globosum</i> (Hochst. ex A. Rich.) Klotzsch	Zambia, Dessein et al. 201 (BR)	EU542918*	EU543019*	EU543078*
Amphiasma Bremek.				
<i>A. benguelense</i> (Hiern) Bremek.	Angola, Kers 3350 (S)	EU542919*	AF002753 ⁽¹⁾	EU543079*
<i>A. luzulooides</i> (K. Schum.) Bremek.	Zambia, Dessein et al. 1167 (BR)	EU542920*	EU543020*	EU543080*
Arcytophyllum Willd. ex Schult. & Schult. f.				
<i>A. aristatum</i> Standl.	Ecuador, Hekker & Hekking 10335 (GB)	—	AF333348 ⁽²⁾	AF333349 ⁽²⁾
<i>A. ciliolatum</i> Standl.	Ecuador, Øllgaard et al. 58395 (NY)	—	AF333350 ⁽²⁾	AF333351 ⁽²⁾
<i>A. ericoides</i> (Willd. ex Roem. & Schult.) Standl.	unknown, Edwin et al. 3624 (S)	—	AF333352 ⁽²⁾	AF333353 ⁽²⁾
<i>A. lavarum</i> K. Schum.	Costa Rica, Cronquist 8827 (NY)	—	AF333354 ⁽²⁾	AF333355 ⁽²⁾
<i>A. macbridei</i> Standl.	Peru, Wurdack 1073 (NY)	—	AF333356 ⁽²⁾	AF333357 ⁽²⁾
<i>A. muticum</i> (Wedd.) Standl.	Colombia, Andersson et al. 2195 (GB)	EU542921*	AF002754 ⁽¹⁾	EU543081*
<i>A. nitidum</i> (Kunth) Schtdl.	Venezuela, Pipoly et al. 6467 (GB)	—	AF333359 ⁽²⁾	—
<i>A. rivetii</i> Danguy & Cherm.	Ecuador, Harling & Andersson 22232 (GB)	EU542922*	AF333362 ⁽²⁾	AF333363 ⁽²⁾
<i>A. serpyllaceum</i> (Schtdl.) Terrell	Mexico, Stafford et al. 203 (MO)	—	AF333364 ⁽²⁾	—
<i>A. setosum</i> (Ruiz & Pav.) Schtdl.	Colombia, Andersson et al. 2196 (GB)	—	AF002755 ⁽¹⁾	AF333365 ⁽²⁾
<i>A. thymifolium</i> (Ruiz & Pav.) Standl.	Ecuador, Ståhl 4481 (GB)	EU542923*	AF333366 ⁽²⁾	EU543082*
Bowardia Salisb.				
<i>B. glaberrima</i> Engelm.	cult., Forbes s.n. (S)	EU542925*	EU543022*	EU543084*
<i>B. ternifolia</i> (Cav.) Schtdl.	unknown, Van Caekenberghe 264 (cult. at BR)	—	AF002758 ⁽¹⁾	—
	Mexico, Spencer et al. 363 (NY)	—	—	EU642537*
Conostomium (Stapf) Cufod.				
<i>C. natalense</i> (Hochst.) Bremek.	South Africa, Dahlstrand 1346 (GB)	—	AF002760 ⁽¹⁾	EU543085*
	South Africa, Bremer et al. 4341 (UPS)	EU542927*	—	—
<i>C. quadrangulare</i> (Rendle) Cufod.	Ethiopia, Puff & Kelbessa 821222 (UPS)	EU542928*	EU543024*	EU543086*
<i>C. zoutpansbergense</i> (Bremek.) Bremek.	South Africa, Bremer et al. 4331 (UPS)	EU542929*	—	EU543087*
Crusea Cham. & Schtdl.				
<i>C. calcephala</i> DC.	Guatemala, Gustafsson et al. 215 (GB)	EU542930*	—	EU543088*
<i>C. megalocarpa</i> (A. Gray) S. Watson	Mexico, Pringle 3852 (S)	EU542931*	EU543025*	EU543089*
Dentella J. R. Forst. & G. Forst.				
<i>D. dioeca</i> Airy Shaw	Australia, Harwood 1559 (BR)	—	—	EU543090*

Appendix 1. Continued.

Taxon	Voucher information	<i>atpB-rbcL</i>	<i>rps16</i> intron	<i>trnL-trnF</i>
<i>D. repens</i> (L.) J. R. Forst. & G. Forst.	Australia, Andersson 2262 (GB)	EU542932*	AF333370 ⁽²⁾	EU543091*
Dibrachionostylus Bremek.				
<i>D. kaessneri</i> (S. Moore) Bremek.	Kenya, Strid 2598 (GB)	EU542933*	AF002761 ⁽¹⁾	–
Diodia L. as traditionally delimited				
<i>D. aulacosperma</i> K. Schum.	Kenya, Luke 9029 (UPS)	EU542934*	EU543026*	EU543092*
<i>D. sarmentosa</i> Sw.	French Guiana, Anderson et al. 2071 (GB)	–	AF002762 ⁽¹⁾	–
<i>D. spicata</i> Miq.	French Guiana, Anderson et al. 1961 (GB)	EU542935*	EU543027*	EU543093*
Enmeorhiza Pohl ex Endl.				
<i>E. umbellata</i> (Spreng.) K. Schum.	Trinidad, Hummel s.n. (GB)	EU542936*	AY764289 ⁽³⁾	EU543094*
Ernodea Sw.				
<i>E. littoralis</i> Sw.	Cuba, Rova et al. 2286 (GB)	EU542937*	AF002763 ⁽¹⁾	EU543095*
Galianthe Griseb.				
<i>G. brasiliensis</i> (Spreng.) E. L. Cabral & Bacigalupo	Argentina, Vanni & Radovancick 996 (GB)	EU542938*	AY764290 ⁽³⁾	EU543096*
<i>G. eupatorioides</i> (Cham. & Schltdl.) E. L. Cabral	Argentina, Schinini & Cristobal 9811 (GB)	EU542939*	EU543028*	EU543097*
Gomphocalyx Baker				
<i>G. herniarioides</i> Baker	Madagascar, De Block et al. 569 (BR)	–	AY764291 ⁽³⁾	–
Hedyotis L.				
<i>H. consanguinea</i> Hance	Hong Kong, Shiu Ying Hu 10821 (S)	EU542941*	–	–
<i>H. fruticosa</i> L.	Sri Lanka, Larsson & Pyddoke 22 (S)	EU542942*	–	EU543098*
<i>H. korrorensis</i> (Valeton) Hosok.	Caroline Islands, Fosberg 47697 (S)	EU542943*	–	EU543099*
<i>H. lawsoniae</i> Wight	Sri Lanka, Wambeck & Wannorp 2996 (S)	EU542944*	–	–
<i>H. lessertiana</i> Arn. var. <i>lassertiana</i> Thwaites	Sri Lanka, Klackenber 413 (S)	EU542945*	EU543029*	EU543100*
<i>H. lessertiana</i> var. <i>marginata</i> Thwaites & Trimen	Sri Lanka, Fagerlind 3668 (S)	EU542946*	EU543030*	EU543101*
<i>H. macrostegia</i> Stapf	Malaysia, Sabah, Wallander 6 (GB)	EU542947*	AF002767 ⁽¹⁾	EU543102*
<i>H. quinquerivis</i> Thwaites	Sri Lanka, Bremer et al. 163 (S)	EU542948*	–	EU543103*
<i>H. rhinophylla</i> Thwaites ex Trimen	Sri Lanka, Fagerlind 5082 (S)	EU542949*	–	EU543104*
<i>H. swertiooides</i> Hook. f.	South India, Klackenber & Lundin 03 (S)	EU542950*	EU543031*	EU543105*
Hedythyrus Bremek.				
<i>H. spermacocinus</i> (K. Schum.) Bremek.	Zambia, Dessen et al. 1017 (BR)	EU542951*	EU543032*	EU543107*
Hemidiodia K. Schum.				
<i>H. ocymifolia</i> (Willd. ex Roem. & Schult.) K. Schum.	French Guiana, Andersson et al. 2040 (GB)	EU542952*	–	EU543108*
Houstonia L.				
<i>H. caerulea</i> L.	U.S.A., Vincent & Lammers s.n. (GB)	EU542953*	AF333379 ⁽²⁾	EU543109*
<i>H. longifolia</i> Gaertn.	U.S.A., Yatskievych 96-49 (MO)	EU542954*	AF002766 ⁽¹⁾	–
	U.S.A., Weigend 9963 (NY)	–	–	EU642536*

Appendix 1. Continued.

Taxon	Voucher information	<i>atpB-rbcL</i>	<i>rps16</i> intron	<i>trnL-trnF</i>
<i>Kadua</i> Cham. & Schtdl.				
<i>K. acuminata</i> Cham. & Schtdl.	U.S.A., Hawaii, cult. at BR	EU542955*	—	EU543110*
<i>K. affinis</i> Cham. & Schtdl.	U.S.A., Hawaii, Motley 1733 (NY)	—	EU642523*	EU642538*
<i>K. axillaris</i> (Wawra) W. L. Wagner & Lorence	U.S.A., Hawaii, Harrison-Gagne s.n. (GB)	—	AF002765 ⁽¹⁾	—
	U.S.A., Hawaii, Maui, Motley 1724 (NY)	—	EU642524*	EU642535*
<i>K. centranthoides</i> Hook. & Arn.	U.S.A., Hawaii, Skottsberg 6788 (S)	EU542956*	EU543033*	EU543111*
<i>K. cordata</i> Cham. & Schtdl.	cult., Lorence 8021 (PTBG)	EU542957*	AF333376 ⁽²⁾	EU543112*
<i>K. coriacea</i> (J. E. Smith) W. L. Wagner & Lorence	U.S.A., Hawaii, Motley 1703 (NY)	—	EU642525*	EU642539*
<i>K. degeneri</i> (Fosberg) W. L. Wagner & Lorence	cult., Wood 5062 (PTGB)	EU542958*	AF333371 ⁽²⁾	EU543113*
<i>K. elatior</i> (H. Mann) W. L. Wagner & Lorence	U.S.A., Hawaii, Kauai, Wagner 6350 (BISH)	—	EU642526*	EU642540*
<i>K. fluviatilis</i> C. N. Forbes	U.S.A., Hawaii, Oahu, Motley 1747 (NY)	—	EU642527*	EU642541*
<i>K. flynnii</i> (W. L. Wagner & Lorence) W. L. Wagner & Lorence	U.S.A., Hawaii, Kauai, Perlman 15631 (BISH)	—	EU642528*	EU642542*
<i>K. foggiana</i> (Fosberg) W. L. Wagner & Lorence	U.S.A., Hawaii, Sparre 27 (S)	EU542959*	—	EU543114*
<i>K. fosbergii</i> (W. L. Wagner & D. R. Herbst) W. L. Wagner & Lorence	U.S.A., Hawaii, Oahu, Motley 1677 (NY)	—	EU642529*	EU642543*
<i>K. laxiflora</i> H. Mann	U.S.A., Hawaii, Molokai, Perlman 6647 (BISH)	—	EU642530*	EU642544*
<i>K. littoralis</i> Hillebr.	U.S.A., Hawaii, Molokai, Kiehn & Luegmayer 920823 (WU)	EU542960*	EU543034*	EU543115*
<i>K. parvula</i> A. Gray	cult., Perlman 12783 (GB)	EU542961*	AF333375 ⁽²⁾	EU543116*
<i>K. rapensis</i> F. Br.	Rapa Island, French Polynesia, Perlman 17953 (NY)	—	EU642531*	EU642545*
<i>Kohautia</i> Cham. & Schtdl.				
<i>K. amatymbica</i> Eckl. & Zeyh.	South Africa, Brenner et al. 4307 (UPS)	EU542962*	EU543035*	EU543117*
<i>K. carpitosa</i> Schinzl.	Zambia, Dessen et al. 432 (BR)	EU542963*	EU543036*	EU543118*
<i>K. coccinea</i> Royle	Zambia, Dessen et al. 751 (BR)	EU542964*	EU543037*	EU543119*
<i>K. cynanchica</i> DC.	South Africa, Dessen et al. 469 (BR)	EU542965*	EU543038*	EU543120*
<i>K. microcala</i> Bremek.	Zambia, Dessen et al. 1149 (BR)	EU542966*	EU543039*	EU543121*
<i>K. obtusiloba</i> (Hiern) Bremek.	Kenya, Luke 9035 (UPS)	EU542967*	EU543040*	EU543122*
<i>K. senegalensis</i> Cham. & Schtdl.	Burkina Faso, Madsen 5940 (NY)	—	—	EU642546*
<i>K. subverticillata</i> (K. Schum.) D. Mantell	Zambia, Dessen et al. 470 (BR)	EU542968*	EU543041*	EU543123*
<i>K. virgata</i> (Willd.) Bremek.	Madagascar, De Block et al. 539 (BR)	EU542969*	—	EU543124*
<i>Lelya</i> Bremek.				
<i>L. osteocarpa</i> Bremek.	Tanzania, Gereau 2513 (BR)	EU542970*	—	EU543125*
<i>Manettia</i> Mutis ex L.				
<i>M. alba</i> (Aubl.) Wernham	French Guiana, Andersson et al. 1917 (GB)	EU542971*	AF002768 ⁽¹⁾	—
<i>M. lygistum</i> (L.) Sw.	Colombia, Andersson et al. 2128 (GB)	EU542972*	AF002769 ⁽¹⁾	EU543126*

Appendix 1. Continued.

Taxon	Voucher information	<i>atpB-rbcL</i>	<i>rps16</i> intron	<i>trnL-trnF</i>
Manostachya Bremek.				
<i>M. ternifolia</i> E. S. Martins	Zambia, Dessein et al. 265 (BR)	EU542973*	EU543042*	EU543127*
Mitracarpus Zucc. ex Schult. & Schult. f.				
<i>M. frigidus</i> (Willd. ex Roem. & Schult.) K. Schum.	French Guiana, Andersson et al. 1995 (GB)	EU542974*	AF002770 ⁽¹⁾	EU543128*
<i>M. microspermus</i> K. Schum.	Guiana, Jansen-Jacobs et al. 4785 (GB)	EU542975*	EU543044*	–
Mitrasacmopsis Jovet				
<i>M. quadrivalvis</i> Jovet	Zambia, Dessein et al. 1273 (BR)	EU542976*	EU543045*	EU543129*
Nesohedyotis (Hook. f.) Bremek.				
<i>N. arborea</i> (Roxb.) Bremek.	cult., Chase 2915 (K)	–	AF003607 ⁽¹⁾	–
Oldenlandia L.				
<i>O. affinis</i> (Roem. & Schult.) DC.	Zambia, Dessein et al. 627 (BR)	EU542977*	EU543046*	EU543130*
<i>O. angolensis</i> K. Schum.	Zambia, Dessein et al. 932 (BR)	EU542978*	EU543047*	EU543131*
<i>O. biflora</i> L.	Japan, Van Caekenberghe 63 (cult. at BR)	EU542979*	–	EU543132*
<i>O. capensis</i> L. f. var. <i>capensis</i>	Zambia, Dessein et al. 843 (BR)	EU542980*	EU543048*	EU543133*
<i>O. capensis</i> var. <i>pleiosepala</i> Bremek.	Tanzania, Kayombo et al. s.n. (BR)	EU542981*	EU543049*	EU543134*
<i>O. corymbosa</i> L.	Zambia, Dessein et al. 487 (BR)	EU542982*	EU543050*	EU543135*
<i>O. echinulosa</i> K. Schum.	Zambia, Dessein et al. 928 (BR)	EU542983*	EU543051*	EU543136*
<i>O. echinulosa</i> K. Schum. var. <i>pellucida</i> (Hiern) Verdc.	Tanzania, Kayombo & Kahemela 1993 (BR)	EU542984*	–	EU543137*
<i>O. fastigata</i> Bremek.	Zambia, Dessein et al. 1019 (BR)	EU542985*	EU543052*	EU543138*
<i>O. galioides</i> (F. Muell.) F. Muell.	Australia, Harwood 1511 (BR)	EU542986*	EU543053*	EU543139*
<i>O. geophila</i> Bremek.	Zambia, Dessein et al. 935 (BR)	EU542987*	EU543054*	EU543140*
<i>O. gorensis</i> (DC.) Summerh.	Zambia, Dessein et al. 1286 (BR)	EU542988*	EU543055*	EU543141*
<i>O. herbacea</i> (L.) Roxb. var. <i>goetzei</i> Bremek.	Zambia, Dessein et al. 442 (BR)	EU542989*	EU543056*	EU543142*
<i>O. herbacea</i> (L.) Roxb. var. <i>herbacea</i>	Zambia, Dessein et al. 463 (BR)	EU542990*	EU543057*	EU543143*
<i>O. lancifolia</i> (Schumach.) DC.	Zambia, Dessein et al. 1356 (BR)	EU542991*	EU543058*	EU543144*
<i>O. microtheca</i> (Cham. & Schltdl.) DC.	Mexico, Frödeström & Hultén 681 (S)	EU542992*	EU543059*	EU543145*
<i>O. mitrasacmoides</i> F. Muell.	Australia, Harwood 1516 (BR)	EU542993*	–	EU543146*
<i>O. nematocaulis</i> Bremek.	Zambia, Dessein et al. 924 (BR)	EU542994*	EU543060*	–
<i>O. nervosa</i> Hiern	Gabon, Andersson & Nilsson 2326 (GB)	–	AF333382 ⁽²⁾	–
<i>O. robinsonii</i> Pit.	Zambia, Dessein et al. 346 (BR)	–	EU543061*	EU543147*
<i>O. rosulata</i> K. Schum.	Zambia, Dessein et al. 1197 (BR)	–	EU543043*	–
<i>O. salzmännii</i> (DC.) Benth. & Hook. f. ex B. D. Jacks.	Brazil, Harley 15514 (UPS)	EU542995*	AY764294 ⁽³⁾	EU543148*
<i>O. taborensis</i> Bremek.	Tanzania, Bidgood et al. 4015 (BR)	EU542996*	–	EU543149*
<i>O. tenelliflora</i> (Blume) Kuntze	Japan, Van Caekenberghe 70 (cult. at BR)	EU542997*	EU543062*	EU543106*
<i>O. tenuis</i> K. Schum.	Guyana, Jansen-Jacobs et al. 41 (UPS)	EU542998*	AY764293 ⁽³⁾	–

Appendix 1. Continued.

Taxon	Voucher information	<i>atpB-rbcL</i>	<i>rps16</i> intron	<i>trnL-trnF</i>
<i>O. uniflora</i> L.	U.S.A., <i>Godfrey 57268</i> (GB)	EU542999*	AY764295 ⁽³⁾	EU543150*
<i>O. wauensis</i> Schweinf. ex Hiern	Ethiopia, <i>Friis et al. 2560</i> (UPS)	EU543017*	EU543076*	EU543168*
<i>O. wiedemannii</i> K. Schum.	Kenya, <i>Luke & Luke 8362</i> (UPS)	EU543000*	EU543063*	EU543151*
Pentanopsis Rendle				
<i>P. fragrans</i> Rendle	Ethiopia, <i>Gilbert et al. 7458</i> (UPS)	–	EU543065*	EU543153*
Pentodon Hochst.				
<i>P. pentandrus</i> (K. Schum. & Thonn.) Vatke	Zambia, <i>Dessein et al. 598</i> (BR)	EU543002*	EU543066*	EU543154*
Phyllohydrax Puff				
<i>P. carnosa</i> (Hochst.) Puff	South Africa, <i>Bremer 3783</i> (UPS)	EU543003*	EU543067*	–
<i>P. madagascariensis</i> (Willd. ex Roem. & Schult.) Puff	Madagascar, <i>De Block et al. 640</i> (BR)	EU543004*	AY764292 ⁽³⁾	EU543155*
Richardia L.				
<i>R. scabra</i> L.	Colombia, <i>Andersson et al. 2073</i> (GB)	EU543005*	AF003614 ⁽¹⁾	EU543156*
<i>R. stellaris</i> (Cham. & Schltdl.) Steud.	Australia, <i>Egerod 85343</i> (GB)	EU543006*	EU543068*	EU543157*
Spermacoce L.				
<i>S. capitata</i> Ruiz & Pav.	French Guiana, <i>Andersson 1908</i> (GB)	EU543007*	EU543069*	EU543158*
<i>S. confusa</i> Rendle ex Gillis	Colombia, <i>Andersson et al. 2074</i> (GB)	–	AF003619 ⁽¹⁾	–
<i>S. erosa</i> Harwood	Australia, <i>Harwood 1148</i> (BR)	EU543008*	EU543070*	EU543159*
<i>S. flagelliformis</i> Poir.	Madagascar, <i>De Block et al. 794</i> (BR)	EU543010*	EU543072*	EU543161*
<i>S. filituba</i> (K. Schum.) Verdc.	Kenya, <i>Luke 9022</i> (UPS)	EU543009*	EU543071*	EU543160*
<i>S. hispida</i> L.	Sri Lanka, <i>Wanntorp et al. 2667</i> (S)	EU543011*	EU543073*	EU543162*
<i>S. prostrata</i> Aubl.	Colombia, <i>Andersson et al. 2078</i> (GB)	EU543012*	–	EU543163*
<i>S. remota</i> Lam.	French Guiana, <i>Andersson et al. 2016</i> (GB)	EU543013*	–	EU543164*
<i>S. ruelliae</i> DC.	Gabon, <i>Andersson & Nilsson 2296</i> (GB)	EU543014*	EU543074*	EU543165*
Stenaria (Raf.) Terrell				
<i>S. nigricans</i> (Lam.) Terrell	U.S.A., <i>Yatskievych 96-92</i> (MO)	EU543015*	AF333373 ⁽²⁾	EU543166*
Synaptantha Hook. f.				
<i>S. tillaeacea</i> (F. Muell.) Hook. f.	Australia, <i>Lazarides & Palmer 272</i> (K)	EU543016*	EU543075*	EU543167*
OUTGROUP TAXA				
Batopedina Verdc.				
<i>B. pubinellata</i> Robbr.	Zambia, <i>Dessein et al. 264</i> (BR)	EU542924*	EU543021*	EU543083*
Carpalea Juss.				
<i>C. madagascariensis</i> Lam.	Madagascar, <i>De Block et al. 578</i> (BR)	EU542926*	EU543023*	–
Pentania Harv.				
<i>P. parviflora</i> Stapf ex Verdc.	Zambia, <i>Dessein et al. 678</i> (BR)	EU543001*	EU543064*	EU543152*

FOLIAR AND PETIOLE ANATOMY OF TRIBE HAMELIEAE AND OTHER RUBIACEAE¹

Dorismilda Martínez-Cabrera,² Teresa Terrazas,³
and Helga Ochoterena³

ABSTRACT

In this study, foliar and petiole anatomy of several genera was compared to determine whether there are characteristics that can be used to reevaluate the circumscription and taxonomic position of Hamelieae (Rubiaceae). Our sample included a total of 36 species, which were sectioned using conventional embedding and staining methods. From these species, 23 represented six of the seven genera of Hamelieae sensu Robbrecht; *Syringantha* Standl. was included in order to reevaluate its putative inclusion within Hamelieae. For comparative purposes, the sample also included representative species of tribes Psychotrieae (Rubioideae), the *Portlandia* informal group (Cinchonoideae), and Gardenieae (Ixoroideae). Our results indicated that foliar and petiole anatomy contained taxonomic information that can be used in systematic studies. Members of Hamelieae shared the following characters: cuticle more than 3 μm , dorsiventral mesophyll, a single palisade parenchyma cell layer, loose spongy parenchyma, raphides, tannins, and vascular tissue of types I, II, or III in the midrib and petiole. *Plocaniophyllon* Brandegee is unique in having fibers associated with major and minor veins. The petiole vascular tissue has an open arc shape in all studied species except in *Randia* L., which has a closed cylinder. Hamelieae, *Syringantha*, and *Psychotria* L. have raphides, one layer of palisade parenchyma cells, and loose spongy parenchyma, while the other taxa have druses, two layers of palisade parenchyma cells, and compact spongy parenchyma. *Bouvardia* Salisb. is unique, showing both raphides and druses. Our results show that comparative foliar and petiole anatomy may provide additional characters to be considered in taxonomic and phylogenetic studies within Rubiaceae. There was anatomical support for the inclusion of *Syringantha* within Hamelieae, while the presence of raphides and the mesophyll attributes suggest an understanding of why Hamelieae was morphologically treated as a member of Rubioideae.

Key words: *Bouvardia*, druses, fibers, leaf trace, *Plocaniophyllon*, raphides, *Syringantha*.

The taxonomic usefulness of leaf and petiole anatomical features for recognizing genera or circumscribing generic, tribal, or family level is well known (Metcalf & Chalk, 1950; Smith & Stern, 1962; Baas & Kool, 1983; Wilkinson, 1983; Dickison, 1989; Engel, 1992; Mentink & Baas, 1992; Buijsen, 1995; Dickison & Weitzman, 1996; Sandoval-Zapotitla & Terrazas, 2001; Aoyama & Graças-Sajo, 2003; Fariña et al., 2003; Dos Reis et al., 2004; Souza et al., 2004; Andrés-Hernández & Terrazas, 2006). However, in Rubiaceae, which includes nearly 13,100 species classified into 611 genera (Govaerts et al., 2006), only a few studies have examined foliar and petiole anatomy (Metcalf & Chalk, 1950; Herman et al., 1986; Kocsis et al., 2004).

Robbrecht (1988, 1993) proposed a classification that divides the family into four subfamilies: Antirheoideae, Cinchonoideae, Ixoroideae, and Rubioideae. According to phylogenetic analyses based on molecular data, Antirheoideae is polyphyletic, while Rubioideae has been the most stable (e.g., Verdcourt, 1958; Bremekamp, 1966; Bremer, 1987; Robbrecht,

1988, 1993; Robbrecht & Manen, 2006). The tribe Hamelieae was traditionally placed into the subfamily Rubioideae, largely because of the presence of raphides. However, phylogenetic analyses based on molecular characters, which included a few representative species of this tribe, indicated that Hamelieae would be more appropriately classified in Cinchonoideae (Bremer et al., 1995; Andersson & Rova, 1999; Robbrecht & Manen, 2006).

The circumscription of the tribe Hamelieae itself has been controversial. Classifications have included between two (*Hamelia* Jacq. and *Hoffmannia* Sw. [Verdcourt, 1958, 1976; Bremekamp, 1966; Elias, 1976]) and 11 genera (*Alibertia* A. Rich. ex DC., *Axanthes* Blume, *Brignolia* DC., *Evosmia* Kunth, *Hamelia*, *Olostyla* DC., *Patima* Aubl., *Tepesia* C. F. Gaertn., *Urophyllum* Jack ex Wall., *Sabicea* Aubl., and *Schradera* Vahl [de Candolle, 1830; Endlicher, 1836]). More recently, Bremer (1987) redefined the tribe on the basis of morphological characteristics, the most important of which were inflorescences ebracteate or with very small scale-like bracts, alternate or

¹The senior author thanks the Consejo Nacional de Ciencia y Tecnología for a scholarship (159282) to conduct her doctoral studies. We are grateful to the curators of CHAPA and MEXU for loaning us material for this study. Thanks are also extended to Miguel Angel Pérez Farrera and Cesario Catalán for helping us to collect in the states of Chiapas and Guerrero.

²Programa de Botánica, Colegio de Postgraduados, Montecillo, México D.F., 56230, Mexico. doris@colpos.mx.

³Departamento de Botánica, Instituto de Biología, Universidad Nacional Autónoma de México, 70-233 México D.F. 04510, Mexico. tterrazas@ibiologia.unam.mx.

doi: 10.3417/2006196

right-rotated quincuncial imbricate corolla aestivation and tetramerous yellow flowers with a usually bicarpellate pistil. With this definition, the tribe includes *Deppea* Cham. & Schltdl., *Hamelia*, *Hoffmannia*, *Omiltemia* Standl., and *Pinarophyllon* Brandege. This delimitation was accepted by Robbrecht (1988). Subsequently, Robbrecht (1993) revised the classification of Rubiaceae and, based on comments by Lorence and Dwyer (1988), added to Hamelieae the genera *Eizia* Standl. and *Plocaniophyllon* Brandege. A few years later, McDowell (1996) revived the monotypic genus *Syringantha* Standl. (considered by Robbrecht [1993] as a synonym of *Exostema* (Pers.) Bonpl.), asserting that it is closely related to *Hamelia*, with which it shares the presence of raphides and floral morphological characteristics, which suggests that *Syringantha* merits inclusion into the tribe Hamelieae. More recently, based on a supertree analysis, Robbrecht and Manen (2006) amended the tribe Hamelieae to include Hillieae (*Cosmibuena* Ruiz & Pav. and *Hillia* Jacq.), *Chione* DC. (formerly classified within Chiococceae – *Portlandia* group), and *Cosmocalyx* Standl. (formerly considered as incertae sedis). Nevertheless, in Robbrecht and Manen's (2006) proposal, only the genera with analyzed DNA sequences were mentioned, leaving out many taxa considered in previous classifications, among which are four genera included by Robbrecht (1993) as part of Hamelieae: *Eizia*, *Omiltemia*, *Pinarophyllon*, and *Plocaniophyllon*, plus *Syringantha*. For this reason, the current most comprehensive proposal for the classification of the tribe is that of Robbrecht (1993) and this is the one followed in the present study.

In this study, the utility of leaf and petiole anatomy in the systematics of Hamelieae is evaluated. Six genera classified by Robbrecht (1993) within the tribe are studied (*Deppea*, *Hamelia*, *Hoffmannia*, *Omiltemia*, *Pinarophyllon*, and *Plocaniophyllon*). In addition, *Syringantha* (tribe Cinchoneae, subfamily Cinchonoideae sensu Robbrecht [1988]) and a synonym of *Exostema* sensu Robbrecht (1993) was included in order to reevaluate McDowell's proposal (1996) to resurrect it and classify it within Hamelieae. For comparative purposes, other genera of different tribes and subfamilies were also considered in the study.

MATERIAL AND METHODS

To evaluate the utility of leaf and petiole anatomy for generic and tribal classification, complete leaves of 23 species representing six genera (Appendix 1) of Hamelieae sensu Robbrecht (1993) were described: *Deppea* (11/27 spp.), *Hamelia* (5/17 spp.), *Hoffmannia* (6/111 spp.), *Omiltemia* (2/2 spp.), *Pinarophyllon* (1

spp.), and *Plocaniophyllon* (1 sp.). We sampled more than 25% of the recognized species for each genus in Hamelieae, except *Hoffmannia*, being careful to represent the described morphological diversity of each genus. For comparative purposes, 13 species of the following genera were also considered in the study (Appendix 1): *Exostema*, because of the previous consideration of *Syringantha* as a synonym of it; *Hintonia* Bullock, as potentially related to *Exostema* (both belonging to the informal *Portlandia* group, within Cinchonoideae); *Psychotria* L. (Psychotrieae), as a comparative stable member of Rubioideae; *Randia* L. (Gardenieae), as a comparative stable member of Ixoroideae; and *Bouvardia* Salisb., as another genus with unstable subfamilial affinities (Hedyotideae–Rubioideae or Cinchoneae–Cinchonoideae).

Leaves of those species were collected in the field and fixed in formalin-acetic acid-alcohol (FAA) (Ruzin, 1999). From Hamelieae sensu Robbrecht (1993), only *Eizia* is not included in this study because we have not been able to find it in the field, and this monotypic genus with a restricted distribution in the state of Chiapas, Mexico, is only known from the type collection. We attempted to include representative species of *Cosmibuena*, *Cosmocalyx*, and *Hillia*, which were considered as Hamelieae sensu Robbrecht and Manen (2006), but we have not been able to find them in the field and it was impossible to section leaves from herbarium material.

Voucher specimens of the newly collected material were deposited at MEXU and CHAPA herbaria (acronyms following Holmgren et al., 2004). In addition to the personal collections, leaves from herbarium specimens (Appendix 1) were used to complete the sampling and to increase the number of individuals sampled per species (two or more individuals were sampled per species). Leaves from the herbarium material were rehydrated in 5% NaOH at 60°C for 1 h. and fixed in FAA for 24 h. All samples were dehydrated in a Leica (Wetzlar, Germany) automatic TP1020 changer, embedded in paraffin, sectioned (transverse and paradermal) 14 µm thick with a rotary microtome, stained with safranin-fast green, and mounted in Euparal (Carolina Supplies, Burlington, North Carolina, U.S.A.) synthetic resin. Terminology follows Metcalfe (1979) and Mentink and Baas (1992) for leaf, Wilkinson (1979) for cuticle, and Howard (1979) for petiole anatomy. It should be noted that previous studies in which petiole vascular tissue was described have used the terms "main vascular bundle" and "lateral vascular bundle" or "median vascular strand and accessory bundles" to refer to the central trace and lateral bundles, respectively (Metcalfe & Chalk, 1950; Herman et

al., 1986; Kocsis et al., 2004). Because the position of the tissues is the same, we consider them homologous. In this paper, therefore, we use the terms “central trace” and “lateral bundles” proposed by Howard (1979).

RESULTS

INDUMENT

Simple unicellular and/or multicellular trichomes are present in most studied species; only *Plocaniophyllon* has glabrous leaves. Within Hamelieae, the simple multicellular trichomes are the most common, and unicellular trichomes are present only in *Hamelia* (Fig. 1A), where they are 27–48 μm long and thin walled ($< 2 \mu\text{m}$). Outside Hamelieae, *Syringantha* and *Bouvardia* also have simple unicellular trichomes, being exclusively of this type in the first genus. The simple multicellular trichomes have up to eight cells in most members of the tribe, but in *Pinarophyllon* they have 10 to 11 cells (Fig. 1B), a range also present only in *Hintonia*. Trichomes are commonly present on lamina, midrib, and margins (Table 1). They have mostly thin walls ($< 2 \mu\text{m}$), but within Hamelieae in *Deppea*, simple multicellular trichomes have thicker walls (3–5 μm), and *Syringantha* and *Bouvardia* have the thickest walls (5–6 μm) (Table 1).

CUTICLE

The cuticle may be smooth (Fig. 1C), but cuticular striations occur frequently, and both can be found in some genera of Hamelieae, as well as *Deppea* and *Hoffmannia*, and in *Psychotria* and *Randia* of other tribes (Table 1, Fig. 1D–F). Cuticle thickness is less than 3 μm in Hamelieae; genera of other tribes have thicker cuticles (Table 1).

EPIDERMAL CELLS

In surface views, unspecialized epidermal cells generally show the entire range from straight to undulating anticlinal walls (Fig. 1G, H), varying among the genera of Hamelieae and other tribes. Straight walls are common on the adaxial surface, while undulating walls dominate in the abaxial epidermis in some genera, namely *Hamelia* and *Pinarophyllon* of Hamelieae and *Exostema*, *Hintonia*, and *Randia* of the *Portlandia* group and Gardenieae. In transverse section, the epidermal cells are mostly square or rectangular on both surfaces, or exclusively ellipsoid shaped with a short dome in the outer periclinal cell walls in the cases of *Hamelia* and *Pinarophyllon* within Hamelieae (Fig. 1A, B), and in *Exostema*, *Hintonia*, and *Randia* outside Hamelieae

(Table 1), whereas *Bouvardia* has a nipple-shaped papillae in adaxial surface (Fig. 1F).

THE STOMATAL COMPLEX

Stomata occur on the lower epidermis and are superficial. Mostly paracytic stomata (Fig. 1I) with two to three subsidiary cells occur among the sampled species (Table 1), but parallelocytic stomata (Fig. 1J) are also present in *Hoffmannia*, *Omitemia*, and *Pinarophyllon* and are exclusive in *Plocaniophyllon*. Subsidiary cells show straight or undulating walls (Fig. 1I, J). However, in *Deppea*, only the larger subsidiary cells have undulating walls. Stomatal size mostly varies between 30 and 45 μm in length. Giant stomata are present in four genera of Hamelieae (*Hoffmannia*, *Omitemia*, *Pinarophyllon*, and *Plocaniophyllon*) and in *Psychotria* (Table 1).

MESOPHYLL

All the material studied showed dorsiventral mesophyll. The palisade tissue consists of one adaxial layer in Hamelieae (Fig. 2A) and *Syringantha*, one to two adaxial layers in *Bouvardia* and *Psychotria*, and two layers in the other genera (Table 1, Fig. 2B). The spongy zone varies from two to six cell layers. Cell arrangement is loose in all material studied from Hamelieae, *Syringantha*, and *Psychotria*, and compact in the remaining studied species (Table 1).

CELLULAR CONTENTS

Crystals are present exclusively as raphides in the mesophyll and midrib in genera of Hamelieae (Fig. 2C), *Syringantha*, and *Psychotria*. Druses occur in specialized cells, idioblasts, in the mesophyll of *Exostema* and *Randia* (Fig. 2D), while druses and raphides are present in *Bouvardia* (Fig. 2E). Dark-staining deposits are also common in the mesophyll (Fig. 2F) and are sometimes associated with the phloem of major and minor veins in Hamelieae (Table 1); they are present but scarce in *Syringantha* and *Psychotria*. The restriction of crystals and dark-staining deposits to particular tribes suggests the potential taxonomic value of these features. Only the leaves of *Hintonia* lack dark cell contents.

MIDRIB

In Hamelieae, the midrib is commonly raised on the abaxial surface and grooved or raised adaxially as seen in transverse sections (Fig. 3). The cuticle has similar characteristics to those of the lamina, but reaches higher (up to 6 μm) in *Deppea* and *Hoffmannia*; outside Hamelieae it is also thin in *Psychotria*

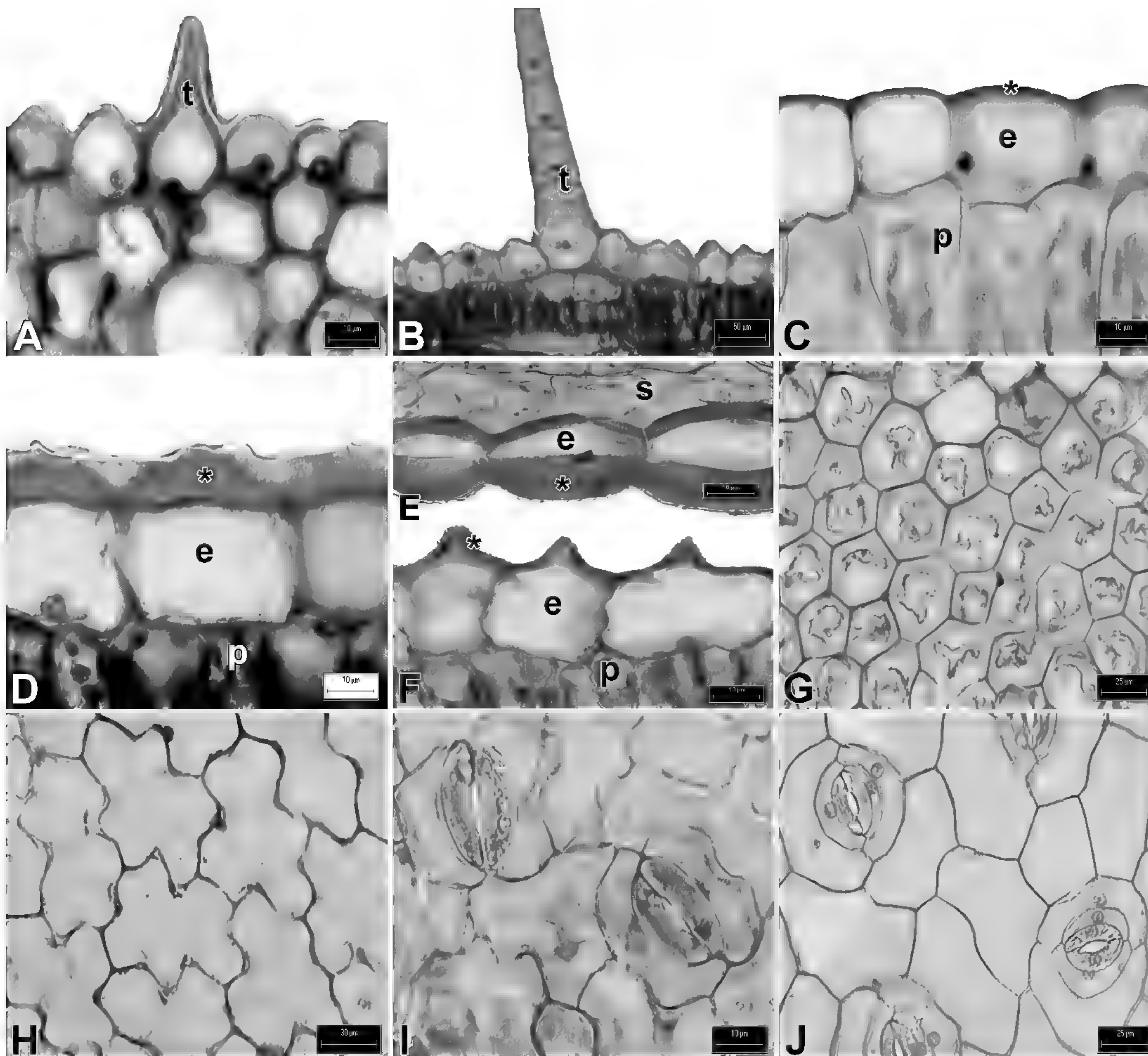

Figure 1. Foliar anatomy of the tribe Hamelieae and other Rubiaceae. —A. *Hamelia* (*H. Vibrans* 5885, MEXU), simple unicellular trichome. —B. *Pinarophyllon* (*D. Martínez et al.* 317, CHAPA), simple multicellular trichome. —C. *Deppea* (*H. Ochoterena* 335, MEXU), smooth cuticle in adaxial epidermis. —D. *Syringantha* (*D. Martínez* 190, CHAPA), cuticular striations in adaxial epidermis. —E. *Bouvardia* (*J. Rzedowski* 39784, MEXU), cuticular striations in abaxial epidermis. —F. *Bouvardia* (*J. Rzedowski* 39784, MEXU), cuticular striations in adaxial epidermis. —G. *Hamelia* (*D. M. Arias & D. Martínez* 2198, MEXU), adaxial epidermis with straight anticlinal cell wall. —H. *Hoffmannia* (*A. Log & M. A. Heath* 154, MEXU), adaxial epidermis with undulating anticlinal cell walls. —I. *Exostema* (*H. Ochoterena* 289, MEXU), paracytic stomata. —J. *Omiltemia* (*M. A. Heath & A. Long* 1173, MEXU), parallelocytic stomata. Scale bars: A — 50 µm; B–F, I — 10 µm; G, J — 25 µm; H — 30 µm. *, cuticle; e, epidermis; p, palisade parenchyma; s, spongy parenchyma; t, trichome.

and thicker and more variable in members of other tribes (Table 2). In transverse sections, the epidermal cells are ellipsoid shaped with a short dome in the outer periclinal cell walls in abaxial epidermis and periclinally elongated in adaxial epidermis in most genera, but exclusively ellipsoid shaped on both surfaces in *Hoffmannia* and *Pinarophyllon*, and in *Psychotria* and *Randia*. The angular or lacunar collenchyma consists of two to eight cell layers below the abaxial epidermis and two to 10 cell layers in the adaxial epidermis (Fig. 3, Table 2). The vascular bundles are collateral. The variation in the vascular tissue of the midrib was classified into five types

(Table 2). In *Deppea*, *Exostema*, *Hintonia*, and *Bouvardia*, it is a simple open arc (type I, Fig. 3A). In *Hamelia*, it is also a simple open arc, but with invaginated ends and a pair of lateral bundles (type II, Fig. 3B). In the remaining genera of Hamelieae as well as in *Syringantha*, it is a simple open arc with slightly curved ends and a pair of lateral bundles (type III, Fig. 3C). In *Psychotria*, the vascular pattern has a V-shaped open arc with invaginated ends and four to six lateral bundles below or between the invaginated ends (type IV, Fig. 3D, E). *Randia* is unique in having a closed ring (type V, Fig. 3F). The vascular tissue has xylem cells in radial rows separated by paren-

Table 1. Characters of foliar anatomy of the Hamelieae, Syringantha, and other representative genera.

Genera	Trichomes			Cuticle		Epidermal cell shape		Stomata		Mesophyll		Contents		
	Type	Cell number	Wall thickness (µm)	Distribution	Type	Thickness (µm)	Adaxial and abaxial	Type	Length (µm)	No. of palisade layers	Spongy parenchyma	Tannins	Crystals	Distribution
Hamelieae														
<i>Deppea</i>	m	3-6	3-5	l, mv, s, t, ma	st (sm)	< 3	el, sq	pc	38.9 (+ 3.2)	1	lo	+	ra	me, ph, a
<i>Hamelia</i>	u, m	2-8	< 2	l, mv, s, ma	st	< 3	el	pc	34.0 (+ 3.8)	1	lo	+	ra	me, ph
<i>Hoffmannia</i>	m	4	< 2	l, mv, ma	st (sm)	≤ 3	re, sq	pc (pl)	67.7 (+ 4.9)	1	lo	+	ra	me, ph, a
<i>Omitelia</i>	m	6-8	< 2	l, mv, ma	sm	< 3	el, sq	pl (pc)	66.2 (+ 7.2)	1	lo	+	ra	me, ph, a
<i>Pinarophyllon</i>	m	10-11	< 2	l, mv, ma	sm	≤ 2	el	pc (pl)	49.8 (+ 3.5)	1	lo	+	ra	me, ph, a
<i>Plocaniophyllon</i>	-	-	-	-	st	≤ 3	sq, re	pl	57.3 (+ 6.8)	1	lo	+	ra	me, ph
Portlandia group														
<i>Syringantha</i>	u	-	5-6	mv	st	> 7	re	pc	39.6 (+ 3.7)	1	lo	+	ra	me
(- <i>Exostema</i>)														
<i>Exostema</i>	m	2-7	< 2	mv, ma	st	4-5	el	pc	33.1 (± 5.0)	2	co		dr	me
<i>Hintonia</i>	m	10-11	< 2	mv	sm	3-4	el	pc	22.4 (± 2.7)	2	co		-	-
Psychotrieae														
<i>Psychotria</i>	m	6-9	2-3	l, mv, s, ma	sm (st)	3-4	el, sq	pc	44.8 (+ 7.0)	1 (2)	lo	+	ra	me
Gardenieae														
<i>Randia</i>	m	3-4	2-4	mv	st, sm	≤ 5	el	pc	30.5 (+ 5.2)	2	co		dr	me, e
Cinchoneae/														
Hedyotideae														
<i>Bouvardia</i>	u, m	3-5	5-6	l, mv, s	st	10-12	el, sq	pc	33.4 (+ 3.2)	1 (2)	co		ra, dr	me

a, arc; co, compact; dr, druses; e, epidermis; el, ellipsoid between epidermis and lamina; l, lamina; lo, loosed; m, multicellular trichome; ma, margin; mv, mesophyll; mv, midrib; pc, paracytic; ph, phloem; pl, parallellocytic; ra, raphides; re, rectangular; s, secondary veins; sm, smooth; sq, square; st, striate; t, tertiary veins; u, unicellular trichome; +, present; -, absent.

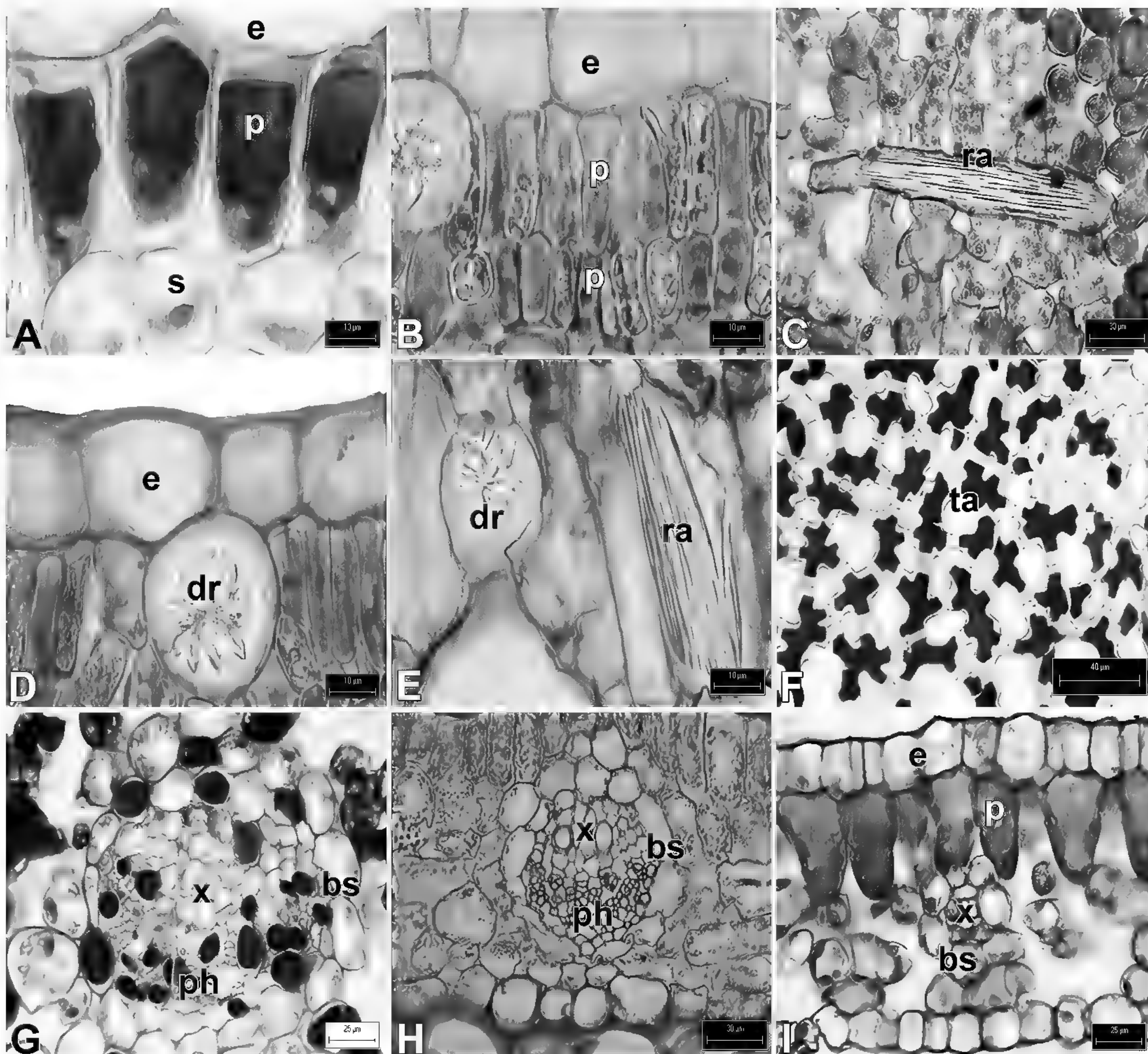

Figure 2. Foliar anatomy of the Hamelieae transverse sections. —A. *Plocaniophyllon* (D. Martínez *et al.* 312, CHAPA), single palisade parenchyma cell layer. —B. *Randia* (H. Iltis 29682, CHAPA), two palisade parenchyma cell layers. —C. *Syringantha* (A. Mora 5314, MEXU), raphides in mesophyll. —D. *Randia* (T. Wendt *et al.* 3131, MEXU), druses in mesophyll. —E. *Bouvardia* (P. Tenorio & C. Romero 1286, CHAPA), raphides and druses in mesophyll. —F. *Pinarophyllon* (D. Martínez *et al.* 316, CHAPA), tannins in spongy parenchyma. —G. *Omiltemia* (D. Martínez 236, CHAPA), secondary vein. —H. *Hintonia* (H. Ochoterena 224, MEXU), tertiary vein. —I. *Hoffmannia* (D. Martínez 187, CHAPA), quaternary vein. Scale bars: A, B, D, E — 10 μm ; C, H — 30 μm ; F — 40 μm ; G, I — 25 μm . bs, bundle sheath; dr, druse; e, epidermis; p, palisade parenchyma; ph, phloem; ra, raphide; s, spongy parenchyma; ta, tannins; x, xylem.

chyma cells with dark-staining deposits. The vascular bundle is enclosed by an arc of parenchyma cells with distinctive dark-staining deposits in Hamelieae and *Syringantha*, except in the case of *Plocaniophyllon*, where the arc enclosing the vascular bundle is composed of fibers. In members of other tribes, the arc enclosing the vascular bundle is more variable, with collenchyma or sclerenchyma (Table 2).

MAJOR AND MINOR VEINS

Major veins are mostly similar to the midrib in their anatomy, with a bundle sheath of parenchyma cells (Fig. 2G, H). The minor veins are also collateral and

have one to two tracheary elements and a sheath of exclusively parenchyma cells in Hamelieae and *Hintonia*, *Psychotria*, and *Randia* (Fig. 2I) and fibers in *Plocaniophyllon*.

PETIOLE

In transverse sections, the petiole is mostly round at the base and winged toward the lamina, except in *Deppea* in which the petiole is reniform at the base, and in *Pinarophyllon* in which it is winged along its entire length. Indument, cuticle, and epidermal cells were observed to be mostly similar to the lamina in all material studied (Table 2, Fig. 4A–E). The number of

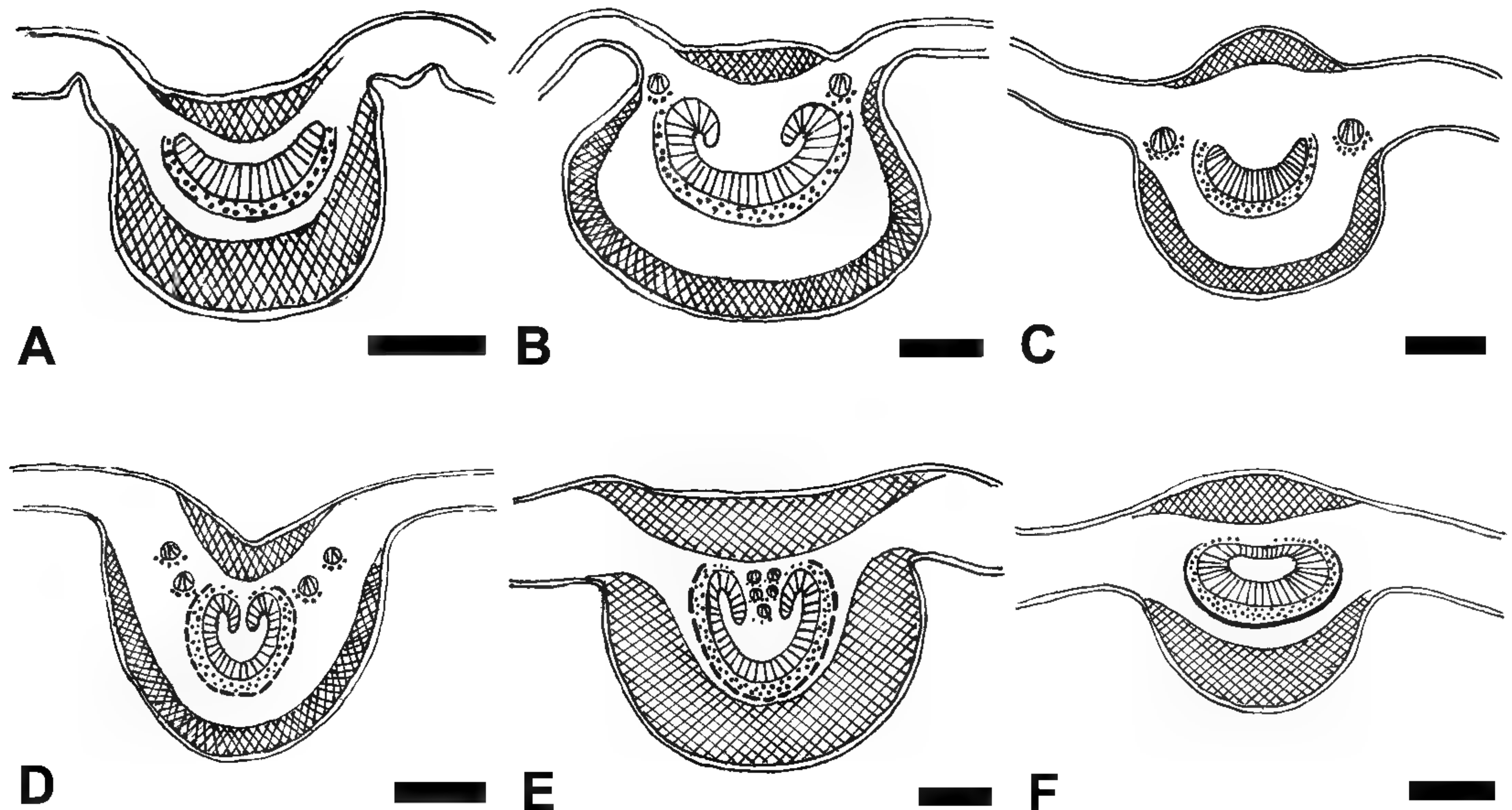

Figure 3. Blade midrib of the Hamelieae and other representatives: vascular tissue shape and distribution types. —A. *Exostema* (*D. Lorence* 3036, CHAPA), type I. —B. *Hamelia* (*Maya* 1868, CHAPA), type II. —C. *Omiltemia* (*A. Méndez* 285, MEXU), type III. —D. *Psychotria* (*Magallanes* 3687, CHAPA), type IV. —E. *Psychotria* (*S. Maya* 1753, CHAPA), type IV. —F. *Randia* (*E. Domínguez & H. Ochoterena* 1775, MEXU), type V. Symbols: hatched line – collenchyma; continuous, thick black line above phloem – fibers; white – parenchyma; narrow black line above phloem – parenchyma with tannins; dotted line – phloem; discontinuous black line above phloem – sclerenchyma; vertical lines – xylem. Scale bars: A–E – 250 μm ; F – 100 μm .

angular or lacular collenchyma cell layers is variable (Fig. 5A–C), with three to five layers being the most common, but up to 12 layers are present in *Deppea* and *Pinarophyllon*. In some species of *Hamelia* and in *Syringantha* and *Randia*, the vascular leaf trace was enclosed by collenchyma. The range of vascular leaf trace patterns in the petiole was classified into six types and is schematically illustrated in Figure 5. In *Deppea* and *Syringantha*, the vascular pattern has only an open arc and a pair of lateral bundles (type I, Fig. 5A) with a continuous parenchymatous sheath with dark-staining deposits occluding the cell lumina (Fig. 4F). In *Hamelia*, the open arc has invaginated ends and only one pair of lateral bundles (type II, Figs. 4G, 5B). Toward the lamina, the central trace is more curved toward the base of the petiole, with the lateral bundles in the same position. The most common leaf trace pattern in Hamelieae consists of an open arc with slightly curved ends, the central leaf trace, and two pairs of lateral bundles (type III, Fig. 5C). Toward the lamina, the central trace is more curved than toward the base of the petiole and it has a continuous parenchymatous sheath with dark-staining deposits occluding the cell lumina. The leaf trace pattern in members of other tribes consists of an open V-shaped arc with straight or invaginated ends and one to two pairs of lateral bundles (types IV, VI, Fig. 5D, E), and a closed ring in *Randia* (type V,

Figs. 4H, 5F). The central leaf trace has a sheath of sclereids in *Psychotria*, fibers in *Randia* (Fig. 4I), or the sheath is absent in members of other studied tribes (Table 2). Cellular contents are similar to those of the mesophyll and midrib (Tables 1, 2, Fig. 4J–L), except in *Hintonia*, which has druses in the collenchyma.

DISCUSSION

Leaf and petiole anatomical characters are quite homogeneous among genera of the tribe Hamelieae. There are, however, certain exceptions, e.g., the genus *Hamelia*, which is characterized by type II vascular tissue in the midrib and petiole, and unicellular and multicellular trichomes, and the genus *Plocaniophyllon*, characterized by the straight anticlinal walls in abaxial and adaxial epidermal cells, parallelcytic stomata with three to four straight-walled subsidiary cells arranged in a C shape, no trichomes, and fibers sheathing the midrib and other veins. Our multiple sampling for the species studied indicates that characters described within the species are constant; however, interspecific variation was found for the number of spongy parenchyma layers, as well as parenchyma and collenchyma layers in the midrib and the petiole. These features are not diagnostic at the genus level. Moreover, trichome type and distribution sometimes varied among species of *Deppea* and

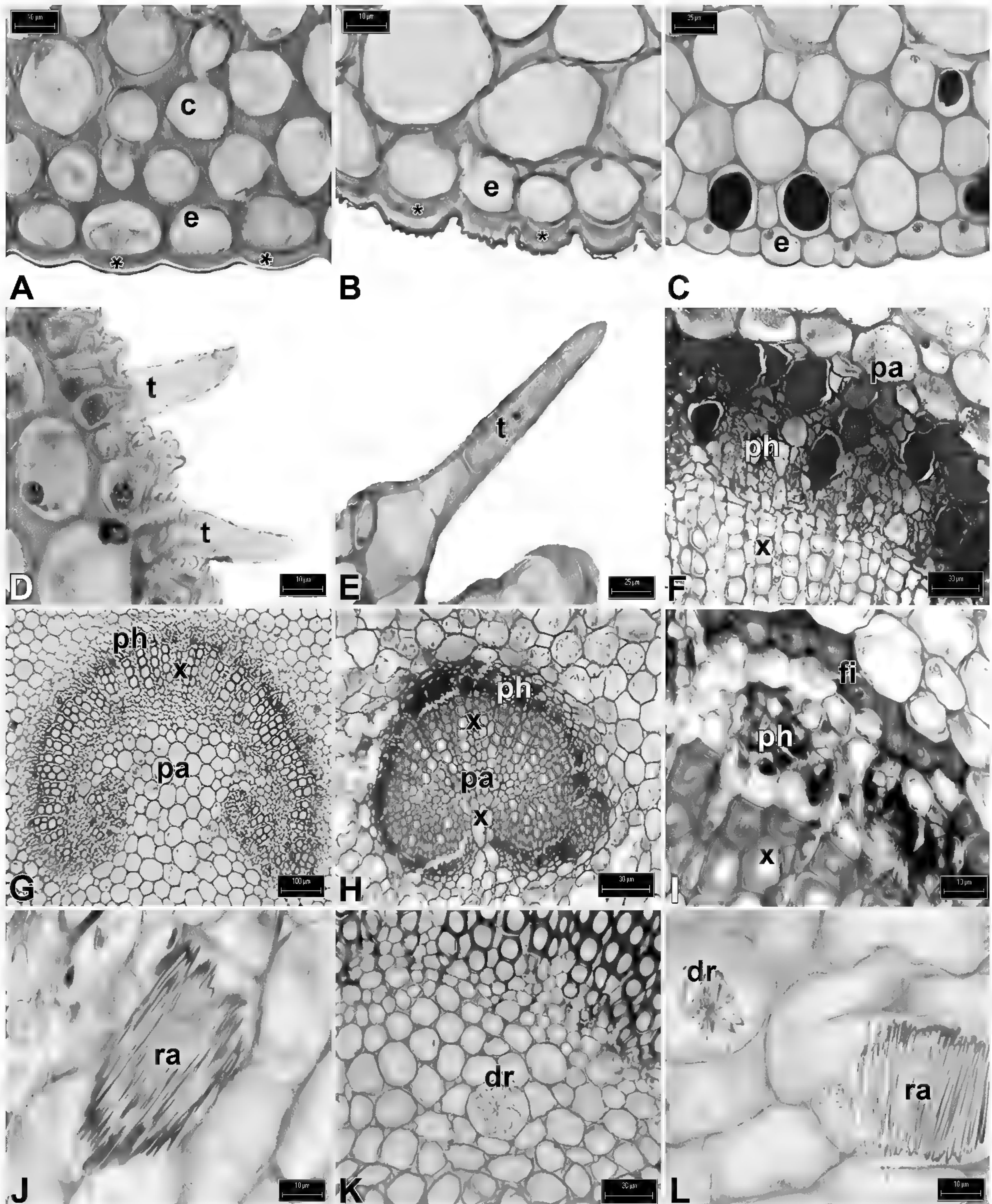

Figure 4. Petiole anatomy within the Hamelieae and other representatives. —A. *Hintonia* (D. Martínez & E. Domínguez 201, CHAPA), abaxial epidermis with smooth cuticle and angular collenchyma. —B. *Exostema* (E. Carranza 3362, CHAPA), abaxial epidermis with striated cuticle and lacunar collenchyma. —C. *Omiltemia* (D. Martínez 275, CHAPA), abaxial epidermis with smooth cuticle and lacunar collenchyma. —D. *Syringantha* (F. González Medrano et al. 4659, MEXU), simple unicellular trichomes. —E. *Psychotria* (E. Martínez et al. 27882, MEXU), simple multicellular trichomes. —F. *Deppea* (D. Martínez 254, CHAPA), parenchyma with tannins above phloem. —G. *Hamelia* (D. Martínez 167, CHAPA), central trace forming an open arc. —H. *Randia* (E. Domínguez & H. Ochoterena 1775, MEXU), central trace forming a closed ring. —I. *Randia* (E. Domínguez & H. Ochoterena 1775, MEXU), fibers sheathing the vascular tissue. —J. *Plocaniophyllon* (D. Martínez et al. 311, CHAPA), raphides in parenchyma. —K. *Exostema* (E. Martínez et al. 29719, MEXU), druses in collenchyma. —L. *Bouvardia* (J. Rzedowski 38901, CHAPA), raphides and druses in parenchyma. Scale bars: A, B, D, I, J, L — 10 µm; C, E — 25 µm; F — 100 µm; G, H, K — 30 µm. *, cuticle; c, collenchyma; dr, druse; e, epidermis; fi, fibers; pa, parenchyma; ph, phloem; ra, raphide; t, trichome; x, xylem.

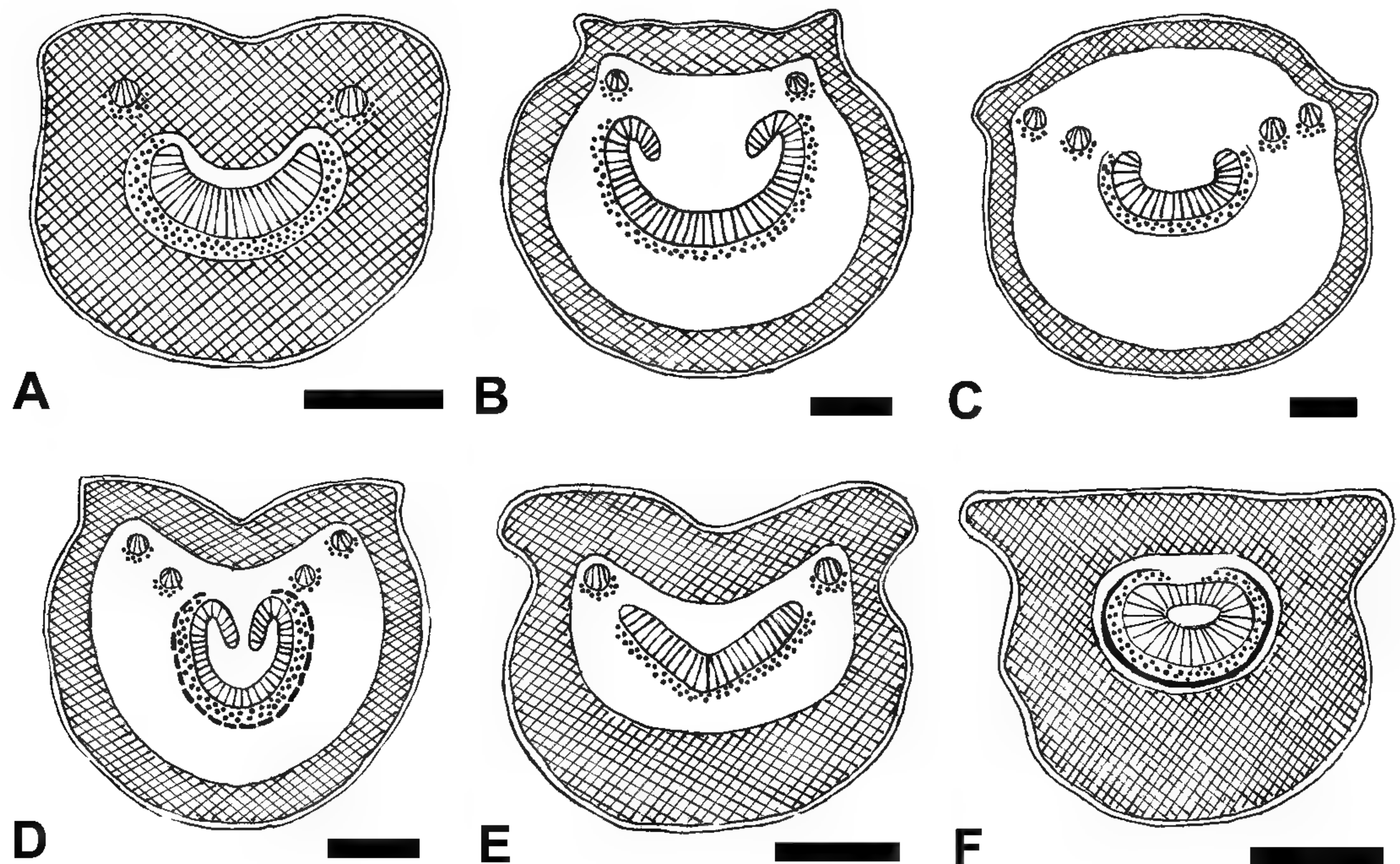

Figure 5. Petiole: vascular tissue types. —A. *Deppea* (J. I. Calzada 5470, MEXU), type I. —B. *Hamelia* (D. Martínez 167, CHAPA), type II. —C. *Hoffmannia* (Cuevas & Guzmán 4185, CHAPA), type III. —D. *Psychotria* (D. Martínez & E. Domínguez 200, CHAPA), type IV. —E. *Bouvardia* (H. Vibrans 4932, CHAPA), type VI. —F. *Randia* (E. Domínguez & H. Ochoterena 1775, MEXU), type V. Symbols: hatched line — collenchyma; continuous thick black line above phloem — fibers; white — parenchyma; narrow black line above phloem — parenchyma with tannins; dotted line — phloem; discontinuous black line above phloem — sclerenchyma; vertical lines — xylem. Scale bars: A–F — 250 μ m.

Hoffmannia, thus a larger sampling in those large genera such as *Deppea* and *Hoffmannia* needs to be studied.

Several types of vascular tissue distribution in the midrib and petiole were recognized, and they appear to be useful diagnostic characters at the generic level. Types I, II, and III were observed in different genera of Hamelieae. *Deppea* has type I, in which the petiole is formed by a multiple trace, with the central trace forming an open arc and a pair of lateral bundles. In the midrib, the lateral bundles are fused to the central trace. *Hamelia* has type II, which is characterized by a multiple trace and with the central trace forming an open arc, with invaginated ends and a pair of lateral bundles. The vascular tissue has the same distribution in the petiole and the midrib. The most common vascular tissue distribution type found in the tribe was type III, observed in the genera *Hoffmannia*, *Omittemia*, *Pinarophyllon*, and *Plocaniophyllon*. In the petiole, the tissue is formed by a multiple trace with the central trace forming an arc, and two pairs of lateral circular bundles. Unlike the petiole, the midrib has only one pair of lateral bundles. In *Deppea*, *Hamelia*, *Hoffmannia*, *Omittemia*, and *Pinarophyllon*, the vascular tissue contains an arc formed by parenchyma cells with tannins above the phloem.

This, together with morphological characters such as the dry, capsular fruit, axial placentation, and numerous small seeds with foveolated-reticulated testa, supports a relationship between *Deppea*, *Omittemia*, *Pinarophyllon*, and *Plocaniophyllon* (Lorence & Dwyer, 1988).

Syringantha shares many lamina and petiole features with Hamelieae, including the single palisade parenchyma layer, loose spongy parenchyma, raphides, and vascular tissue type I in the petiole (as in *Deppea*); and it shares common features of the midrib with *Hoffmannia*, *Omittemia*, *Pinarophyllon*, and *Plocaniophyllon*. These characters support the proposal from McDowell (1996) to include *Syringantha* in the tribe. In addition, *Syringantha* shares with some species of *Hamelia*, as mentioned by McDowell (op. cit.), deciduous stipules, secundiflorous inflorescences, yellow flowers, stamens with flattened filaments, introrse dehiscence, subconical nectariferous disc shape, and smooth to reticulate exine of the pollen grain. *Syringantha* is the only member of the tribe to inhabit drier environments, and its narrowly elliptical leaves and thick cuticle are doubtlessly adaptations to these environments.

Members of Hamelieae share some lamina and petiole characters with the studied representatives of

Table 2. Characters for foliar and petiole anatomy of Hamelieae tribe, *Syringantha*, and other representative genera.

Genera	Midrib						Petiole					
	Cuticle (µm)	Collenchyma (abaxial and adaxial)	Vascular pattern	Vascular type ¹	Arc	Trichome	Cuticle (µm)	Leaf trace type ¹	Central strand sheath	Tannin	Crystals	Distribution
Hamelieae												
<i>Deppea</i>	3-6	3-6, 5-7	o	I	pa	m (u)	< 2	I	pa	+	ra	pa, co ph, vs
<i>Hamelia</i>	< 3	3-5, 5-6	o	II	pa	u, m	≤ 3	II	-	+	ra	pa, co, ph
<i>Hoffmannia</i>	3-6	3, 3	o	III	pa	m	≤ 2	III	pa	+	ra	pa, co, ph, vs
<i>Omiternia</i>	≤ 3	2-6, 2-6	o	III	pa	m	≤ 2	III	pa	+	ra	pa, co, ph, vs
<i>Pinarophyllon</i>	≤ 2	3-4, 10	o	III	pa	m	≤ 3	III	pa	+	ra	pa, co, ph, vs
<i>Plocaniophyllon</i>	≤ 3	5, 5	o	III	fi	-	≤ 3	III	pa	+	ra	pa, co, ph, vs
Cinchoneae												
<i>Syringantha</i>	6-7	8, 10	o	III	pa	u	4-6	I	-	+	ra	pa, co, ph
<i>Exostema</i>	5-6	4-7, 10	o	I	co	u	5-12	VI	-		dr	pa, co
<i>Hintonia</i>	4-5	4-5, 4-6	o	I	co	-	4-6	VI	-		dr	co
Psychotriaceae												
<i>Psychotria</i>	≤ 3	3-6, 3-6	o	IV	scl	m (u)	≤ 3	IV	scl		ra	pa, ph
Gardenieae												
<i>Randia</i>	4-5	4-5, 6	c	V	fi	m	4-5	V	fi		dr	co
Cinchoneae/Hedyotideae												
<i>Bowardia</i>	10-12	4-5, 8	o	I	co	-	5-10	VI	-		ra, dr	pa, co

c, closed cylinder; co, collenchyma; dr, druses; fi, fibers; m, multicellular trichome; o, open arc; pa, parenchyma; ph, phloem; ra, raphides; scl, sclerenchyma; u, unicellular trichome; vs, vascular sheath; +, present; -, absent.

¹ For type definition, see text.

Rubioideae, Cinchonoideae, and Ixoroideae, namely a simple epidermis, stomata restricted to the abaxial surface, and dorsiventral mesophyll. In addition, they share with *Psychotria* (Rubioideae) multicellular trichomes, a single layer of palisade parenchyma cells, loose spongy parenchyma, and occurrence of raphides and tannins. *Psychotria* differs from members of Hamelieae, however, by its lignified elements sheathing the phloem and the presence of vascular tissue type IV in the midrib and petiole. To date, type IV is unique to *Psychotria*, as it has not been recorded in any other member of the family. It is important to study additional species of the genus and other members of tribe Psychotrieae to confirm the diagnostic potential of this characteristic.

The genera *Exostema* and *Hintonia* of the *Portlandia* group (Cinchonoideae) share the presence of midrib vascular tissue type I with *Deppea*, but are distinguished from the tribe Hamelieae by having two layers of palisade parenchyma cells and compact spongy parenchyma with druses, and by the absence of a sheath in the petiole vascular tissue. *Bouvardia* shows vascular tissue type I in the midrib and type VI in the petiole as in *Exostema* and *Hintonia*, but, unlike these genera, *Bouvardia* had raphides and druses in both the lamina and petiole. *Bouvardia* had previously been classified in the tribe Hedyotideae (Rubioideae) because of reports of raphides. Its winged seeds, however, motivated Robbrecht (1988, 1993) to consider it a member of the tribe Cinchoneae (Cinchonoideae). This has not been supported by molecular data (e.g., Robbrecht & Manen, 2006). The presence of raphides and druses in the leaves of this taxon adds support to the idea of an independent origin of raphides and to the exclusion of *Bouvardia* from Rubioideae.

The genus *Randia* of the subfamily Ixoroideae was the only one to have a closed vascular trace in the midrib and petiole (type V). Moreover, the vascular tissue was sheathed by a discontinuous layer of fibrous elements. These characteristics and the presence of druses are a unique combination of characters that distinguish this genus from the other taxa studied. Further sampling should test the taxonomic value of this character and the rank at which it may be useful.

Attributes observed in the studied genera, such as simple epidermis, hypostomatic leaves, and dorsiventral mesophyll, have also been recorded for other taxa of Rubiaceae (Metcalf & Chalk, 1950). Most of the leaf trace types recognized here are described for the first time for the family; thus, vascular tissue diversity in the petiole is higher than that reported by Metcalf and Chalk (1950). Except in *Randia*, the petiole was characterized by an open vascular trace in the genera

observed in the present study. Comparisons of photographs of petiole vascular tissues of *Rondeletia* L. (Cinchonoideae, Kocsis et al., 2004) and *Pavetta* L. (Ixoroideae, Herman et al., 1986) enabled us to confirm that type I, described for *Deppea* of Hamelieae, has a broader distribution. The differences among vascular tissue types recognized in this study are related to the particular shape of the central trace and to whether its endings are curved or straight, and to the number of lateral bundles. Moreover, the number of lateral bundles decreases from the base of the petiole to the midrib in types I, III, and VI. Howard (1979) reported that reduction in the number of traces is a common modification in petiole vascular tissue. Notably, no modification of the foliar trace was observed in types II, IV, and V.

Raphides have been considered a taxonomic marker within Rubiaceae, in particular in delimiting the subfamily Rubioideae (Bremekamp, 1966). It is understandable that Hamelieae has traditionally been classified in this subfamily, as all genera of Hamelieae have raphides. Phylogenetic analyses of molecular data, however, suggest that the tribe should be assigned to the subfamily Cinchonoideae (Bremer et al., 1995; Andersson & Rova, 1999; Robbrecht & Manen, 2006). The presence of raphides in both Rubioideae and Cinchonoideae indicates that these crystals appeared independently in both subfamilies. We consider that it is therefore important to study their ontogeny and chemical composition to evaluate potential homologies within these subfamilies.

The single palisade parenchyma layer, the distribution of vascular tissue in the midrib and petiole (type I, II, or III), and the presence of raphides and tannins are a unique combination of characters that circumscribe the tribe Hamelieae including *Syringantha*. Some of these characters also enable taxonomic delimitation at the genus level within the tribe. This and other studies show that anatomical leaf and petiole characters have taxonomic potential (Herman et al., 1986; Dessein et al., 2001; Piesschaert et al., 2001; Kocsis et al., 2004).

Literature Cited

- Andersson, L. & J. H. Rova. 1999. The *rps16* intron and the phylogeny of the Rubioideae (Rubiaceae). *Pl. Syst. Evol.* 214: 161–186.
- Andrés-Hernández, R. & T. Terrazas. 2006. Anatomía foliar y del pecíolo de especies del género *Rhus* s. str. (Anacardiaceae). *Bol. Soc. Bot. Mex.* 78: 95–106.
- Aoyama, E. M. & M. das Graças Sajo. 2003. Estrutura foliar de *Aechmea* Ruiz & Pav. Subgénero *Lamprococcus* (Beer) Baker e espécies relacionadas (Bromeliaceae). *Revista Brasil. Bot.* 26: 461–473.

- Baas, P. & R. Kool. 1983. Comparative leaf anatomy of *Heisteria* (Olacaceae). *Blumea* 28: 367–388.
- Bremekamp, C. E. B. 1966. Remarks on the position, the delimitation, and the subdivision of the Rubiaceae. *Acta Bot. Neerl.* 15: 1–33.
- Bremer, B. 1987. The sister group of the paleotropical tribe Argostemmatae: A redefined neotropical tribe Hamelieae (Rubiaceae). *Cladistics* 3: 35–51.
- , K. Andreasen & D. Olsson. 1995. Subfamilial and tribal relationships in the Rubiaceae based on *rbcL* sequence data. *Ann. Missouri Bot. Gard.* 82: 383–397.
- Buijssen, J. R. M. 1995. Leaf anatomy of *Harpullia*, *Majidea*, and *Conchopetalum* (Sapindaceae). *Blumea* 40: 345–361.
- Candolle, A. P. de. 1830. *Prodromus systematais naturalis regni vegetabilis*. Paris.
- Dessein, S., S. Jansen, S. Huysmans, E. Robbrecht & E. Smets. 2001. A morphological survey of *Virectaria* (African Rubiaceae), with a discussion of its taxonomic position. *Bot. J. Linn. Soc.* 137: 1–29.
- Dickison, W. C. 1989. Stem and leaf anatomy of the Alseuosmiaceae. *Aliso* 3: 567–578.
- & A. L. Weitzman. 1996. Comparative anatomy of the young stem, node, and leaf of Bonnetiaceae, including observations on a foliar endodermis. *Amer. J. Bot.* 83: 405–418.
- Dos Reis, C., S. L. Proença & M. Graças Sajo. 2004. Vascularização foliar e anatomia do pecíolo de Melastomataceae do cerrado do Estado de São Paulo, Brasil. *Acta Bot. Bras.* 18: 987–999.
- Elias, T. S. 1976. A monograph of the genus *Hamelia* (Rubiaceae). *Mem. New York Bot. Gard.* 26: 81–144.
- Endlicher, S. 1836–1840. *Genera Plantarum secundum ordines naturales disposita*. Friedrich Beck, Vienna.
- Engel, T. 1992. Petiolar anatomy of North American *Astragalus* species (Fabaceae) with persistent petioles. *Aliso* 2: 339–345.
- Fariña, A., D. Arrieche, A. Boada-Sucre & D. Velásquez. 2003. Anatomía comparada de la lámina foliar de las especies de *Heliotropium* L. (Boraginaceae) presentes en Venezuela. *Interciencia* 28: 68–74.
- Govaerts, R., L. Andersson, E. Robbrecht, D. Bridson, A. Davis, I. Schanzer & B. Sonke. 2006. World Checklist of Rubiaceae. The Board of Trustees of the Royal Botanic Gardens, Kew. <<http://www.kew.org/wcsp/>>, accessed 7 February 2006.
- Herman, P. P. J., P. J. Robbertse & N. Grobbelaar. 1986. Leaf anatomy of some southern African *Pavetta* species. *S. Afr. J. Bot.* 56: 489–500.
- Holmgren, P. K., W. Keuken & E. K. Schofield. 2004. *Index Herbariorum*. International Association for Plant Taxonomy. The New York Botanical Garden, Bronx.
- Howard, R. A. 1979. The petiole. Pp. 88–96 in C. R. Metcalfe & L. Chalk (editors), *Anatomy of the Dicotyledons*, Vol. 1, 2nd ed. Clarendon Press, Oxford.
- Kocsis, M., J. Darók & A. Borhidi. 2004. Comparative leaf anatomy and morphology of some neotropical *Rondeletia* (Rubiaceae) species. *Pl. Syst. Evol.* 248: 205–218.
- Lorence, D. H. & J. D. Dwyer. 1988. A revision of *Deppea* (Rubiaceae). *Allertonia* 4: 389–436.
- McDowell, T. 1996. *Syringantha coulteri* (Hooker f.) T. McDowell, a new combination, and remarks on the relationships of the monotypic Mexican genus *Syringantha* Standley (Rubiaceae). *Novon* 6: 273–279.
- Mentink, H. & P. Baas. 1992. Leaf anatomy of the Melastomataceae, Memecylaceae, and Cryptoniaceae. *Blumea* 37: 189–225.
- Metcalf, C. R. 1979. The leaf: General topography and ontogeny of the tissues. Pp. 63–75 in C. R. Metcalfe & L. Chalk (editors), *Anatomy of the Dicotyledons*, Vol. 1, 2nd ed. Clarendon Press, Oxford.
- & L. Chalk. 1950. *Anatomy of the Dicotyledons*, 1st ed. Clarendon Press, Oxford.
- Piesschaert, F., S. Jansen, I. Jaimes, E. Robbrecht & E. Smets. 2001. Morphology, anatomy, and taxonomic position of *Pagameopsis* (Rubiaceae-Rubioideae). *Brittonia* 53: 490–504.
- Robbrecht, E. 1988. Tropical woody Rubiaceae. *Opera Bot. Belg.* 1: 1–271.
- . 1993. Supplement to the 1988 outline of classification of the Rubiaceae. *Opera Bot. Belg.* 6: 173–193.
- & J.-F. Manen. 2006. The major evolutionary lineages of the coffee family (Rubiaceae, angiosperms). Combined analysis (nDNA and cpDNA) to infer the position of *Coptosapelta* and *Luculia*, and supertree construction based on *rbcL*, *rps16*, *trnL-trnF*, and *atpB-rbcL* data. A new classification in two subfamilies, Cinchonoideae and Rubioideae. *Syst. Geogr. Pl.* 76: 85–146.
- Ruzin, E. S. 1999. *Plant Microtechnique and Microscopy*. Oxford University Press, New York.
- Sandoval-Zapotitla, E. & T. Terrazas. 2001. Leaf anatomy of 16 taxa of the *Trichocentrum* clade (Orchidaceae: Oncidiinae). *Lindleyana* 16: 81–93.
- Smith, A. & W. Stern. 1962. Leaf anatomy as an aid in the identification of two Fijian plant species. *Brittonia* 14: 237–247.
- Souza, L. A., I. S. Moscheta & J. H. G. Oliveira. 2004. Comparative morphology and anatomy of the leaf and stem of *Peperomia dahlstedtii* C. DC., *Ottania martiana* Miq., and *Piper diospyrifolium* Kunth (Piperaceae). *Gayana, Bot.* 61: 6–17.
- Verdcourt, B. 1958. Remarks on the classification of the Rubiaceae. *Bull. Jard. Bot. Bruxelles* 28: 209–290.
- . 1976. Rubiaceae Part 1. Pp. 1–414 in R. M. Polhill (editor), *Flora of Tropical East Africa*. Royal Botanical Gardens, Kew.
- Wilkinson, H. P. 1979. Cuticle. Pp. 140–155 in C. R. Metcalfe & L. Chalk (editors), *Anatomy of the Dicotyledons*, Vol. 1, 2nd ed. Clarendon Press, Oxford.
- . 1983. Leaf anatomy of *Gluta* (L.) Ding Hou (Anacardiaceae). *Bot. J. Linn. Soc.* 86: 375–403.

APPENDIX 1. List of specimen vouchers used to produce permanent slides. Species are arranged alphabetically.

- Bouvardia cordifolia* DC. MEXICO. México: *H. Vibrans* 4932 (CHAPA). Michoacán: *J. Rzedowski* 39784 (MEXU). Oaxaca: *A. Campos & L. Cortés* 2203 (MEXU). *B. chrysantha* Mart. MEXICO. Guerrero: *P. Tenorio et al.* 1286 (CHAPA), *R. Torres* 9951 (MEXU). México: *J. A. López & S. E. Hernández* 1277 (CHAPA). *B. ternifolia* (Cav.) Schltdl. MEXICO. Hidalgo: *M. Martínez* 58 (CHAPA), *D. Martínez* 284 (CHAPA). Michoacán: *J. Rzedowski* 38901 (CHAPA).
- Deppea cornifolia* (Benth.) Benth. MEXICO. Guerrero: *D. Martínez* 241 (CHAPA), *J. Rzedowski* 16049 (MEXU). Hidalgo: *R. Hernández et al.* 6119 (MEXU). Oaxaca: *J. Reyes* 419 (MEXU). *D. grandiflora* Schltdl. MEXICO. Chiapas: *M. González et al.* 1015 (CHAPA, MEXU), *S. Maya* 4346 (MEXU), *F. Ventura* 19572 (MEXU). Veracruz: *H. Ochoterena & C. Gallardo* 374 (MEXU). *D. guerrerensis* Dwyer & Lorence. MEXICO. Guerrero: *D. Martínez* 193 (CHAPA), *D. Martínez* 195 (CHAPA), *H. Ochoterena & D. Bailey* 335 (MEXU). *D. hintonii* Bullock. MEXICO. Chiapas: *T. B. Croat* 47234 (CHAPA). Oaxaca: *A. Campos* 1840

(MEXU), *R. E. Gereau et al.* 1075 (MEXU), *T. B. Croat* 46153 (MEXU). *D. miahuatlanica* Lorence. MEXICO. Oaxaca: *A. Campos & L. Cortés* 2260 (MEXU), *H. Ochoterena & D. Bailey* 331 (MEXU), *R. Torres & A. Campos* 10847 (MEXU). *D. microphylla* Greenm. MEXICO. Hidalgo: *D. Lorence* 4895 (MEXU), *J. Rzedowski* 23429 (MEXU). Puebla: *D. Gold* 223 (MEXU). *D. obtusiflora* (Benth.) Benth. MEXICO. Oaxaca: *D. Lorence* 4200 (MEXU), *D. Lorence* 4338 (MEXU), *J. Rivera* 0965 (MEXU). *D. pubescens* Hemsl. MEXICO. Oaxaca: *A. Campos & J. Reyes* 1333 (CHAPA), *H. Ochoterena & D. Bailey* 333 (MEXU), *R. Torres* 1403 (MEXU). *D. purpusii* Standl. MEXICO. Hidalgo: *R. Hernández* 5767 (MEXU), *D. Martínez* 254 (MEXU). Veracruz: *J. I. Calzada* 5470 (MEXU). *D. tenuiflora* Benth. MEXICO. Veracruz: *I. A. Vargas* 189 (MEXU), *I. A. Vargas* 243 (MEXU). *D. umbellata* Hemsl. MEXICO. Oaxaca: *R. Torres* 6546 (MEXU). Veracruz: *J. Fay & J. I. Calzada* 734 (MEXU), *H. Ochoterena et al.* 370 (MEXU), *M. G. Zola* 0390 (MEXU).

Exostema caribaeum (Jacq.) Roem. & Schult. MEXICO. Campeche: *C. Chan* 7698 (CHAPA). Oaxaca: *D. Lorence* 3036 (CHAPA). Querétaro: *E. Carranza* 3362 (CHAPA). *E. mexicanum* A. Gray. MEXICO. Campeche: *E. Martínez* 29166 (CHAPA), *E. Martínez* 29719 (MEXU). Chiapas: *A. Chamé et al.* 159 (CHAPA). Oaxaca: *H. Ochoterena et al.* 289 (MEXU).

Hamelia axillaris Sw. MEXICO. Chiapas: *E. Martínez* 14707 (MEXU). Tabasco: *R. H. Magaña & C. Cowan* 3136 (CHAPA, MEXU). Veracruz: *T. Wendt et al.* 4231 (CHAPA, MEXU), *O. Zambrano* 1026 (CHAPA). *H. patens* Jacq. MEXICO. Chiapas: *F. Ventura* 90 (CHAPA). Hidalgo: *D. Martínez* 167 (CHAPA). Oaxaca: *S. Maya* 1868 (CHAPA). *H. rovirosae* Wernham. MEXICO. Chiapas: *M. González et al.* 796 (CHAPA), *M. González et al.* 797 (CHAPA). Oaxaca: *H. Hernández* 1508 (CHAPA). *H. versicolor* A. Gray. MEXICO. Guerrero: *C. Catalán* 3 (CHAPA). Jalisco: *H. Ochoterena & D. Bailey* 217 (MEXU). Morelos: *D. M. Arias & D. Martínez* 2198 (MEXU). *H. xorullensis* Kunth. MEXICO. Jalisco: *H. Ochoterena & D. Bailey* 220 (MEXU). México: *D. Martínez* 298 (CHAPA), *H. Vibrans* 5885 (MEXU).

Hintonia latiflora (Sessé & Moc. ex DC.) Bullock. MEXICO. Jalisco: *A. Flores* 3655 (CHAPA), *D. Martínez & E. Domínguez* 201 (CHAPA). Sinaloa: *H. Ochoterena & D. Bailey* 224 (MEXU). Sonora: *A. Flores & O. Gutiérrez* 511 (CHAPA). *H. octomera* (Hemsl.) Bullock. MEXICO. Yucatán: *H. Ochoterena & H. Flores* 168 (MEXU).

Hoffmannia angustifolia Standl. MEXICO. Chiapas: *D. E. Breedlove* 24801 (MEXU), *D. E. Breedlove* 35293 (CHAPA),

A. Log & M. Heath 154 (MEXU). *H. conzattii* B. L. Rob. MEXICO. Chiapas: *U. Bachem & R. Rojas* 891 (CHAPA). Guerrero: *E. Martínez et al.* 5070 (MEXU). Hidalgo: *J. Rzedowski* 12341 (CHAPA). Oaxaca: *T. Wendt & M. Ishiki* 4956 (CHAPA). *H. culminicola* Standl. & L. O. Williams. MEXICO. Hidalgo: *D. Martínez* 171 (CHAPA). Oaxaca: *S. Maya* 1173 (CHAPA), *P. Tenorio & R. Torres* 11059 (MEXU). *H. cuneatissima* B. L. Rob. MEXICO. Guerrero: *E. Martínez* 5471 & *F. Barrie* (CHAPA). Jalisco: *R. Cuevas & L. Guzmán* 4185 (CHAPA, MEXU). México: *D. Lorence & D. Tejero* 4887 (MEXU). *H. excelsa* (Kunth) K. Schum. MEXICO. Oaxaca: *S. Maya* 3305 (CHAPA). Veracruz: *D. Lorence* 3890 (MEXU), *G. Castillo* 12149 (MEXU). *H. nicotanaefolia* (M. Martens & Galeotti) L. O. Williams. MEXICO. Chiapas: *M. González et al.* 1718 (CHAPA), *E. Martínez* 18864 (MEXU). Oaxaca: *T. Wendt et al.* 4661 (CHAPA).

Omiltemia filisepala (Standl.) C. V. Morton. MEXICO. Chiapas: *M. Heath & A. Long* 771 (MEXU), *M. Heath & A. Long* 1173 (MEXU), *D. Martínez* 275 (CHAPA). *O. longipes* Standl. MEXICO. Guerrero: *F. Lorea* 2048 (MEXU), *D. Martínez* 236 (CHAPA), *A. Méndez* 285 (MEXU).

Pinarophyllon flavum Brandegee. MEXICO. Chiapas: *D. E. Breedlove* 30795 (MEXU), *D. Martínez* 318 (CHAPA), *E. Ventura & E. López* 2053 (MEXU).

Plocaniophyllon flavum Brandegee. MEXICO. Chiapas: *M. Heath & A. Long* 899 (MEXU), *D. Martínez* 312 (CHAPA), *E. Matuda* 17763 (MEXU).

Psychotria erythrocarpa Schltdl. MEXICO. Guerrero: *C. Catalán & F. Terán* 709 (CHAPA). Oaxaca: *S. Maya* 1691 (CHAPA), *S. Maya* 1753 (CHAPA). *P. faxlucens* Lorence & Dwyer. MEXICO. Veracruz: *R. Cedillo* 3587 (CHAPA), *S. Sinaca* 579 (CHAPA). *P. horizontalis* Sw. MEXICO. Chiapas: *E. Martínez* 9030 (MEXU). Jalisco: *D. Martínez* 200 (CHAPA), *J. A. S. Magallanes* 3687 (CHAPA). *P. microdon* (DC.) Urb. MEXICO. Campeche: *E. Martínez* 27882 (MEXU). Chiapas: *E. Palacios* 1995 (CHAPA, MEXU). Jalisco: *D. Martínez* 205 (CHAPA).

Randia aculeata L. MEXICO. Jalisco: *E. Domínguez & H. Ochoterena* 1775 (MEXU). Nayarit: *O. Téllez* 12663 (CHAPA). Veracruz: *T. Wendt et al.* 3131 (CHAPA). *R. tetraantha* (Cav.) DC. MEXICO. Jalisco: *D. Martínez* 309 (CHAPA), *H. Iltis et al.* 29682 (CHAPA).

Syringantha coulteri (Hook. f.) T. McDowell. MEXICO. Hidalgo: *D. Martínez* 190 (CHAPA), *F. G. Medrano et al.* 9631 (MEXU). Guanajuato: *E. Ventura & E. López* 7989 (MEXU). Tamaulipas: *Mora* 5314 (MEXU).

PARAPHYLY OF *IXORA* AND NEW
TRIBAL DELIMITATION OF
IXOREAE (RUBIACEAE):
INFERENCE FROM COMBINED
CHLOROPLAST (*RPS16*, *RBCL*,
AND *TRNT-F*) SEQUENCE DATA¹

Arnaud Mouly,^{2,3} Sylvain G. Razafimandimbison,³
Jacques Florence,⁴ Joël Jérémie,² and
Birgitta Bremer³

ABSTRACT

We performed phylogenetic analyses of DNA sequences of three chloroplast markers: *rbcL*, *rps16*, and *trnT-F*, to rigorously test the monophyly of competing circumscriptions of the tribe Ixoreae. Several genera traditionally or currently associated with the type genus *Ixora* L. were included in the analyses. *Ixora* as currently circumscribed appears paraphyletic, as many other genera are nested within it with strong support: *Captaincookia* N. Hallé, *Doricera* Verdc., *Hitoa* Nadeaud, *Myonima* Comm. ex Juss., *Sideroxyloides* Jacq., *Thouarsiora* Homolle ex Arènes, and *Versteegia* Valetton. Further, *Aleisanthia* Ridl., *Aleisanthiopsis* Tange, and *Greenea* Wight & Arn. are more closely related to *Ixora* and allies than the monotypic genus *Scyphiphora* C. F. Gaertn. Consequently, Ixoreae fide Andreasen and Bremer (2000) is not monophyletic without an exclusion of *Scyphiphora*. Ixoreae fide Robbrecht and Manen (2006) is not monophyletic unless *Captaincookia* and *Doricera* are included. The monophyly of a morphologically heterogeneous Ixoreae alliance consisting of *Ixora* and its relatives *Aleisanthia*, *Aleisanthiopsis*, and *Greenea* is, however, strongly supported. In order to recognize monophyletic and morphologically consistent groups, we adopt a narrow circumscription of Ixoreae (including *Bemsetia* Raf., *Captaincookia*, *Charpentiera* Vieill., *Doricera*, *Hitoa*, *Ixora*, *Myonima*, *Pancheria* Montrouz., *Sideroxyloides*, *Thouarsiora*, *Tsiangia* But, H. H. Hsue & P. T. Li, and *Versteegia*), and two new tribes are erected for *Aleisanthia* + *Aleisanthiopsis* and *Greenea*, respectively. The Indo-Malesian Aleisanthieae and the pantropical Ixoreae s. str. are sister groups, and the Southeast Asian Greeneeae is sister to the Ixoreae–Aleisanthieae clade.

Key words: Aleisanthieae, cpDNA, Greeneeae, *Ixora*, Ixoreae, Ixoroideae, phylogeny, Rubiaceae.

The large pantropical genus *Ixora* L. was earlier classified either in the tribe Pavetteae (Richard, 1829; Dumortier, 1829) or the tribe Coffeae (Wight & Arnott, 1834) until Gray (1858) placed it in his new tribe Ixoreae (Table 1), which now belongs to the subfamily Ixoroideae sensu Bremer et al. (1999). Ixoreae initially consisted of two large Linnaean genera, *Ixora* (the type genus) and *Pavetta* L., with contorted aestivation and peltate or centrally affixed ovules (Gray, 1858), but the genus *Coffea* L., presently classified in Coffeae, was later added (Hooker, 1873; Bremekamp, 1934). From 1979 to 2000, both *Ixora*

and *Pavetta* were placed either in Coffeae (Darwin, 1979; Verdcourt, 1989) or in Pavetteae (Bridson & Robbrecht, 1985; Robbrecht, 1988). Phylogenetic studies of Ixoroideae conducted by Andreasen and Bremer (1996, 2000) based on the combined molecular and morphological data demonstrated for the first time that *Ixora* and *Pavetta* were not closely related genera. The monotypic and mangrove genus *Scyphiphora* C. F. Gaertn. (Gaertner, 1806), formerly classified in the tribe Gardenieae sensu Robbrecht (1988), was resolved with moderate support (jackknife [JK] = 70%, Andreasen & Bremer, 2000: 1740) as

¹The authors wish to thank Anbar Khodabandeh and Torsten Eriksson for technical help and support with laboratory work and analyses; the Missouri Botanical Garden for kindly providing material for DNA extraction; the director and team of the Nationaal Herbarium Nederland, University Leiden branch (The Netherlands) for access to their collections; and the director and team of National Botanic Garden of Belgium for access to their collections. Financial support was provided by the Unité Mixte de Service Centre National de Recherche Scientifique 2700–Unité de Service du Muséum Muséum National d’Histoire Naturelle 0602 “Taxonomie et Collections,” the Department “Systématique et Evolution,” MNHN, Paris, and the European Union through the Synthesys program to A. Mouly; by the French Polynesian Government to J. Florence; and by the Swedish Research Council and the Knut and Alice Wallenberg Foundation to B. Bremer. The authors wish to acknowledge the two anonymous reviewers for useful comments on an early version of the manuscript.

²UMS 2700 CNRS–USM 0602 MNHN: Taxonomie et Collections, Département de Systématique et Évolution, Muséum National d’Histoire Naturelle, Herbar National, CP 39, 16 rue Buffon, 75231 Paris CEDEX 05, France.

³Bergius Foundation, Royal Swedish Academy of Sciences and Botany Department, Stockholm University, SE-106 91 Stockholm, Sweden. arnaud@bergianska.se.

⁴US 084 IRD BIODIVAL: Biodiversité végétale tropicale: connaissance et valorisation, Institut de Recherche pour le Développement, Antenne MNHN, Herbar National, CP 39, 16 rue Buffon, 75231 Paris CEDEX 05, France.

doi: 10.3417/2006194

Table 1. Historic comparison of classification schemes for the tribe Ixoreae and related taxa. Question marks mean that the authors tentatively included the genus in the indicated tribe.

	Dumortier, 1829 fide Richard, 1829	Wight & Arnott, 1834	Gray, 1858	Hooker, 1873	Bremekamp, 1934	Darwin, 1979	Bridson & Robbrecht, 1985	Robbrecht, 1988	Verdcourt, 1989	Andreasen & Bremer, 2000	Robbrecht & Manen, 2006	Present classification
<i>Ixora</i>	Pavetteae	Coffeae	Ixoreae	Ixoreae	Ixoreae	Coffeae	Pavetteae	Pavetteae	Coffeae	Ixoreae	Ixoreae	Ixoreae
<i>Pavetta</i>	Pavetteae	Coffeae	Ixoreae	Ixoreae	Ixoreae	Coffeae	Pavetteae	Pavetteae	Coffeae	Pavetteae	Pavetteae	Pavetteae
<i>Coffea</i>	Coffeae	Coffeae	Ixoreae	Ixoreae	Ixoreae	Coffeae	Coffeae	Coffeae	Coffeae	Coffeae	Coffeae	Coffeae
<i>Aleisanthia</i>								Rondeletieae			Ixoreae	Aleisanthieae
<i>Aleisanthiopsis</i>								Rondeletieae			Ixoreae	Aleisanthieae
<i>Captaincookia</i>							Pavetteae	Pavetteae		Ixoreae		Ixoreae
<i>Doricera</i>							Pavetteae	Pavetteae	Coffeae	Ixoreae		Ixoreae
<i>Greenea</i>								Rondeletieae			Ixoreae	Greeneae
<i>Hitoea</i>						Coffeae	Pavetteae					Ixoreae
<i>Myonima</i>				Ixoreae	Ixoreae?		Pavetteae	Pavetteae	Coffeae	Ixoreae	Ixoreae	Ixoreae
<i>Scyphiphora</i>		Guettardeae				Cremalesporeae		inc. sedis		Ixoreae?	Ixoreae	inc. sedis
<i>Sideroxyloides</i>				Ixoreae								Ixoreae
<i>Thouarsiora</i>							Pavetteae					Ixoreae
<i>Versteegia</i>					not Ixoreae		Pavetteae	Pavetteae		Ixoreae	Ixoreae	Ixoreae

sister to a strongly supported (JK – 100%, Andreasen & Bremer, 2000: 1740) clade consisting of four species of *Ixora* and one species each of the genera *Myonima* Comm. ex Juss. (Jussieu, 1789) and *Versteegia* Valetton (Valetton, 1911). Accordingly, Andreasen and Bremer (2000) reinstated and recircumscribed Ixoreae to include *Captaincookia* N. Hallé (Hallé, 1973), *Doricera* Verdc. (Verdcourt, 1983, 1989), *Ixora*, *Myonima*, and *Versteegia*; they tentatively placed *Scyphiphora* there. The tribe comprises ca. 510 species, some of which are economically important (e.g., the ornamental *I. coccinea* L., *I. finlaysoniana* Wall. ex G. Don, and *I. hookeri* (Oudem.) Bremek.). It is characterized by a combination of articulated petioles (De Block, 1998), terminal inflorescences, and 4-merous flowers with aestivation contorted to the left (Andreasen & Bremer, 2000). Pavetteae and Coffeeae were recircumscribed in a narrow sense.

Andreasen and Bremer (2000) also revealed that *Ixora*, represented by four species, was paraphyletic or polyphyletic. About 500 species (98%) of Ixoreae were encountered in the pantropical *Ixora* (Mouly, 2007). Several described monotypic genera, including *Becheria* Ridl. (Ridley, 1912), *Bemsetia* Raf. (Rafinesque, 1838), *Hitoa* Nadeaud (Nadeaud, 1899), *Pancheria* Montrouz. (Montrouzier, 1860; nom. rej.), *Patabea* Aubl. (Aublet, 1775), *Sideroxyloides* Jacq. (Jacquin, 1763), and *Thouarsiora* Homolle ex Arènes (Arènes, 1960), are considered to fall within *Ixora* based on morphology (Bentham, 1850; Beauvisage, 1901; Fosberg, 1937; Sandwith, 1937; Guédès, 1986; Smith & Darwin, 1988; De Block, 1998). The monotypic genus *Charpentiera* Vieill. (nom. illeg.), previously attributed to the family Loganiaceae (Vieillard, 1865), was included in *Ixora* (Rubiaceae) by Beauvisage (1901). The genus *Tsiangia* But, H. H. Hsue & P. T. Li (But et al., 1986) was described for a species based on a single specimen from Hong Kong, but Bridson (2000) stressed that this species was a deviant parasitized collection of *I. chinensis* Lam. *Captaincookia*, *Doricera*, and *Scyphiphora* remain monotypic genera, and *Myonima* and *Versteegia* contain only four and five species, respectively. Baillon (1879) merged *Myonima* with *Ixora* as a section, but subsequent Rubiaceae taxonomists did not follow this.

A recent phylogenetic study by Rova et al. (2002: 149) based on the *trnL-F* chloroplast region revealed for the first time a close relationship of *Ixora* with three Southeast Asian genera, *Aleisanthia* Ridl. (Ridley, 1920; Tange, 1996a), *Aleisanthiopsis* Tange (Tange, 1996b), and *Greenea* Wight & Arn. (Wight & Arnott, 1834), which were formerly classified in the tribe Rondeletieae of the subfamily Cinchonoideae

(Robbrecht, 1988). Malesian *Aleisanthia* and Indonesian *Aleisanthiopsis* are two small genera, each with two species. *Greenea* is a genus from Southeast Asia (Puff et al., 2005) with ca. 10 species. These three rainforest genera have contorted aestivation, scorpioid inflorescences, and capsular multiseeded fruits, features unknown in Ixoreae sensu Andreasen and Bremer (2000). More recently, Robbrecht and Manen (2006) proposed a broad circumscription of Ixoreae including *Ixora*, *Myonima*, *Scyphiphora*, *Versteegia*, and the above three genera. Their Ixoreae is diagnosed by contorted corolla aestivation, a feature commonly found in Ixoroideae s.l.

Sequencing data from the *rps16*, *trnT-F*, and *rbcL* chloroplast markers have been used separately and/or in combination with that of the ITS of nuclear ribosomal DNA (nrDNA) for assessing phylogenetic relationships in some rubiaceous groups (e.g., Razafimandimbison & Bremer [2001] for *rbcL* and ITS; Razafimandimbison & Bremer [2002], Lantz & Bremer [2004], Alejandro et al. [2005] for *trnT-F* and ITS). Here, we perform phylogenetic analyses using DNA sequencing data from the three chloroplast regions to reconstruct a robust phylogeny for Ixoreae. The resulting phylogeny from the combined data is used to rigorously test the monophyly of previous circumscriptions.

MATERIAL AND METHODS

TAXONOMIC SAMPLING

We used 33 species (Appendix 1) comprising seven *Ixora* species with a representative geographical range, one individual each for the monotypic genera *Captaincookia*, *Doricera*, *Hitoa*, *Scyphiphora*, *Sideroxyloides*, and *Thouarsiora*, a specimen of one species each for *Myonima*, *Versteegia*, *Aleisanthia*, and *Aleisanthiopsis* (two accessions), five representatives of *Greenea*, two members of the tribe Vanguerieae (*Peponidium cystiporon* (Byn. ex Cavaco) Razafim., Lantz & B. Bremer and *Cyclophyllum deplanchei* Hook. f.), and one species each for the nine formally recognized tribes of Ixoroideae s.l. (Andreasen & Bremer, 2000; Rova et al., 2002), notably *Pavetta* for Pavetteae. Despite available names under *Ixora*, the species of the genera *Hitoa* and *Sideroxyloides* are used in the study to clearly assess the circumscription of Ixoreae, with those of *Ixora* being addressed in another study. *Luculia gratissima* (Wall.) Sweet was used as outgroup taxon (Appendix 1), in agreement with its basal position in Rubiaceae. Several specimens of *Greenea* included in the analyses could not be identified at species level. We were unable to include any representatives of the genera *Bemsetia* and *Patabea*

as they are only known from their respective type illustrations, and failed in obtaining sequences from extracted samples of *Becheria*, *Charpentiera*, and *Pancheria*. Several taxa were included in the study using accessions from the GenBank database, and we were not always able to obtain complementary material to complete missing data within the data sets (Appendix 1).

DNA EXTRACTION, AMPLIFICATION, SEQUENCING, AND ALIGNMENT

Total DNA was extracted from dried material preserved in silica gel (Chase & Hillis, 1991) or herbarium specimens following the mini-prep procedure of Saghai-Marooof et al. (1984), as modified by Doyle and Doyle (1987). Extracted DNA was cleaned with the QIAquick polymerase chain reaction (PCR) purification kit (Qiagen, Solna, Sweden). PCR reactions were as follows: 27.25 μ l of H₂O, 5 μ l of PCR buffer, 5 μ l of MgCl₂, 5 μ l of 0.1 M tetramethylammonium chloride (TMACl), 4 μ l of dNTP, 0.25 μ l of Taq DNA polymerase (AB-0192 & AB-0192/b; ABGene, Cambridge, U.K.), 0.5 μ l of each primer, and 0.5 μ l of 1% of bovine serum albumin (BSA). PCR amplifications, performed in an Eppendorf Mastercycler (Applied Biosystems, Life Technologies, Carlsbad, California, U.S.A.) gradient, started with an initial melting phase of 2 min. at 95°C, followed by 35 to 37 cycles of 30 sec. at 95°C, 1 min. at 50°C–55°C, and 2 min. at 72°C and ended with a final extension phase of 7 min. at 72°C. In all PCR runs, one reaction was run with water instead of DNA as a negative control to check for contamination.

The *rps16* intron was amplified with the primer pair *rpsF/rpsR2* (Oxelman et al., 1997). For half of the species, we repeatedly failed to obtain amplification in one reaction because of a problematic poly A/T at the 3' end of the intron (Shaw et al., 2005). However, amplification was successful with the internal primer pair *rpsF2/rpsR3* (Bremer et al., 2002), but resulted in sequences 50–70 bp shorter. The entire *trnT-F* region (including the two *trnL* introns) was amplified in two parts. The *trnT-trnL* segment was amplified with the primer pair A1/I (Bremer et al., 2002; Lantz & Bremer, 2004). The second part, *trnL-trnF*, was amplified with primers *c/f* (Taberlet et al., 1991). For *trnL-trnF*, sequencing reactions were performed using the two external primers *c/f* and two internal primers *d/e* (Taberlet et al., 1991) to produce complete sequences of the entire region *trnT-F* with at least partial overlaps (from 20–150 bp). The *rbcL* coding region was amplified in two parts. The first segment was amplified with the primer pair z1/1020R (Andreasen & Bremer, 2000) and the second segment with the couple 3'/427BS (Olmstead et al., 1992;

Andreasen & Bremer, 2000). Sequencing reactions were performed with z1/1020R for the first segment and with 3'/427BS and two internal primers 1204R/895 (Andreasen & Bremer, 2000) for the second part to produce complete sequences of the entire region of *rbcL*, with at least partial overlaps (from 60–90 bp). All sequencing reactions of the markers were performed with Big Dye Terminator v1.1 Cycle Sequencing kit or the Big Dye Terminator v3.1 Cycle Sequencing kit (Applied Biosystems) and subsequently analyzed on a 3100 Genetic Analyzer (Applied Biosystems).

The *rps16*, *trnT-F*, and *rbcL* sequences were assembled using the Staden Package version 1.6.0 beta-test (Staden, 1996) or Sequencher 3.1.1 (Gene Codes Corporation, Ann Arbor, Michigan, U.S.A.) and edited manually. Sixty-seven accessions from 33 taxa are new to this paper (Appendix 1). All sequences were aligned manually with Se-AL v1.0al (Rambaut, 1996). The insertion of numerous gaps in nucleotide sequences was required during the alignment procedure for both *trnT-F* and *rps16* (Table 2). Other studies have shown indels to be reliable characters (Lloyd & Calder, 1991; Giribet & Wheeler, 1999; van Dijk et al., 1999; Delarbre et al., 2000; Freudenstein & Chase, 2001; Rouhan et al., 2004). Unambiguous insertions and deletions (indels) were then coded as additional characters by using 0 and 1 symbols for deletions and insertions, respectively (Swofford, 1993).

PHYLOGENETIC ANALYSES

Bayesian analyses were performed with MrBayes 3.0b4 (Huelsenbeck & Ronquist, 2001). The Bayesian approach evaluates the posterior probability (PP) of a tree given the character matrix, i.e., the probability that the tree is correct. A partitioned Bayesian analysis was conducted to account for the combination of molecular data with various evolution patterns and standard binary characters of gap coding. For each partition, MrModeltest 2.0 (Nylander, 2004) was used to choose the model of nucleotide substitution that best fit the data, following Akaike's Information Criterion Calculation Method (Akaike, 1974). The selected models were general time reversible (GTR) (Yang, 1994), with among-site substitution rate heterogeneity described by a gamma distribution and all sites constrained to be variable (GTR + G) for *rps16* and the *trnT-L* segment, GTR with a fraction invariant site constraint (GTR + I) for the *trnL-F* segment, and GTR + G + I for *rbcL*. Unambiguous indels were analyzed as an additional partition and treated as binary characters. All analyses were conducted with four independent Markov chains run

Table 2. Indication of the number of accessions included, the length of the aligned matrices, the number of informative characters, and parsimony indices in each data set.

	<i>rps16</i>	<i>trnT-F</i>	<i>rbcL</i>	Combined data
No. of accessions	33	32	29	34
Matrix length	773	1726	1373	3872
Parsimony informative characters	72 (68 substitutions + 4 indels)	148 (119 substitutions + 29 indels)	68 (68 substitutions)	288 (255 substitutions + 33 indels)
Parsimony indices	L – 228; CI – 0.851; RI – 0.883	L – 455; CI – 0.855; RI – 0.888	L – 233; CI – 0.712; RI – 0.785	L – 936; CI – 0.809; RI – 0.851

L, length; CI, consistency index; RI, retention index.

for 2×10^6 Metropolis-coupled Markov chain Monte Carlo (MCMC) generations, with tree sampling every 1×10^3 generations, and burn-in after 500 trees (as detected by plotting the log likelihood scores against generation number). The analyses were run three times using different random starting trees to evaluate the convergence of the likelihood values and posterior clade probabilities (Huelsenbeck et al., 2002). The consensus tree was built using selected trees from each run. Groups characterized by a PP of more than 0.95 were regarded as strongly supported.

To test the topologies inferred from Bayesian analyses, parsimony analyses were also conducted using PAUP* 4.0b8b (Swofford, 2002). The maximum parsimony (MP) trees were found by heuristic search, tree bisection-reconnection (TBR) branch swapping, using 1×10^4 replicates of random stepwise addition, with the MULTREES option on. Characters were given equal weight, gaps were treated as missing data, and only phylogenetically informative indels were coded. The consistency index (CI) (Kluge & Farris, 1969) and the retention index (RI) (Farris, 1989) were calculated to estimate homoplasy. To assess relative support for the identified clades, bootstrap values (BS) (Felsenstein, 1985) were estimated from 1×10^4 replicates, the MULTREES option off, TBR branch swapping, and five random addition sequences. Groups characterized by a bootstrap support of more than 95% were regarded as strongly supported.

To test the null hypothesis that our data sets were homogeneous with respect to phylogenetic information, we used the incongruence length difference test (ILD, also called partition homogeneity test; Farris et al., 1994), as implemented in PAUP*. Invariant sites were removed (Cunningham, 1997) and 1×10^4 replications were performed. The results of the partition homogeneity test indicated that the *rps16*, *trnT-F*, and *rbcL* trees were significantly incongruent ($P = 0.0009$). However, the accuracy of the ILD test tends to be low when the number of the informative

sites is low (Yoder et al., 2001; Darlu & Lecointre, 2002), which is presently observed (Table 2). According to Bremer et al. (2002) and despite incongruence, we favored an analysis of combined data sets.

RESULTS

The results of the analyses conducted in this study are given in the following section, where the sequence characteristics of the individual data sets (Fig. 1, Table 2, unpublished figure for *rbcL*, available from the author for correspondence) are presented, and detailed outputs from the analysis of the combined data sets are given (Fig. 2, Table 2).

SEPARATE ANALYSES

The separate *rps16* and *trnT-F* analyses (Fig. 1A, B), as well as the *rbcL* analysis, all identified the following monophyletic groups: the *Ixora* group (forming seven *Ixora* species, *Hitoea*, *Sideroxyloides*, *Thouarsiora*, *Captaincookia*, *Doricera*, *Myonima*, and *Versteegia*), the *Greenea* group, the *Aleisanthia*–*Aleisanthiopsis* group (not tested for monophyly in the *rbcL* analysis due to the single representative), and Vanguerieae (represented by *Peponidium cystiporon* Byn. ex Cavaco and *Cyclophyllum deplanchei*). Furthermore, *Ixora* was shown to be polyphyletic and *Scyphiphora* left unresolved in a basal position in the Ixoreae alliance. While both the *rps16* and *trnT-F* trees (Fig. 1A, B) identified a highly supported clade containing *Aulacocalyx jasminiflora* Hook. f., *Augusta austrocaledonica* (Brongn.) J. H. Kirkbr., and all sequenced members of the tribes Pavetteae (sensu Andreasen & Bremer, 2000), Octotropideae, Cremasporae, Coffeae, and Albertae, this clade was unresolved in the *rbcL* tree (not included). The *Aleisanthia*–*Aleisanthiopsis* group was resolved with high support (BS 99%, PP 1.00) as sister to the *Ixora* group in the *trnT-F* tree (Fig. 1B). This sister-group

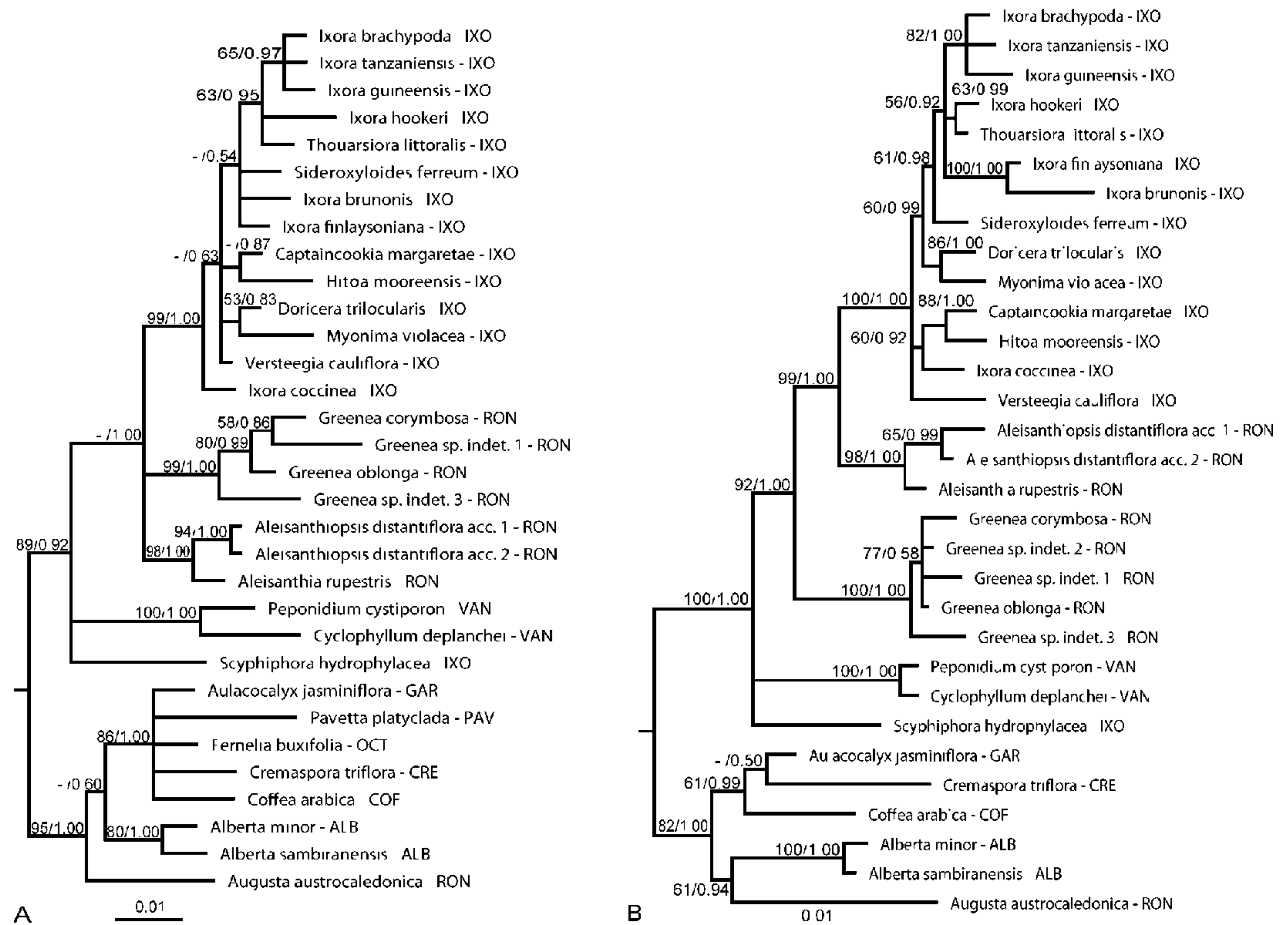

Figure 1. Majority consensus tree inferred from Bayesian analyses of separated markers alignments (2 M generations) of Ixoroideae. —A. Topology generated from the *rps16* data set. —B. Topology generated from the *trnT-F* data set. Numbers above nodes indicate bootstrap support from the parsimony analysis of identifiable nodes (left) and consensus of Bayesian posterior probabilities (right). Bootstrap values less than 50% or unresolved nodes are not indicated. Other groups representing recognized tribes of the Ixoroideae sensu Andreasen and Bremer (2000) are abbreviated as follows: ALB, Alberteae; COF, Coffeae; CRE, Cremasporae; GAR, Gardenieae; IXO, Ixoreae; OCT, Octotropideae; PAV, Pavetteae; VAN, Vanguerieae. Species recently included to Ixoroideae from Rondeletieae are annotated RON. Outgroups were removed from trees.

relationship was collapsed in the *rps16* tree (Fig. 1A), while the *Aleisanthia*–*Aleisanthiopsis* group (represented by *Aleisanthiopsis distantiflora* accession 1) and the *Greenea* group were resolved with poor support (BS 55%, PP 0.70) as sister groups in the *rbcL* tree. Within the *Ixora* group, there were some poorly to weakly supported differences between the *rps16*, *trnT-F* (Fig. 1A, B), and *rbcL* trees.

COMBINED ANALYSES

To perform phylogenetic analyses of combined data, we merged the three matrices for all 34 terminal samples (represented in at least two of the three chloroplast DNA [cpDNA] markers) in a combined data set of 3872 sites, including 288 (7.44%) parsimony informative characters. Of the informative characters, 255 (88.54%) were nucleotide substitutions and 33 (11.45%) were indels. In our study, the combined *rps16*–*rbcL*–*trnT-F* tree (Fig. 2) identified

the similar larger monophyletic groups retained in the separate analyses (Fig. 1A, B) with strong support. Internal nodes received high support (Fig. 2). The overall tree topologies of the tree generated from both the parsimony and Bayesian combined analyses were, in general, similar to those of the *rps16* and *trnT-F* trees (Fig. 1A, B). The ingroup taxa were resolved in two main clades, noted as A and B (Fig. 2). Clade A was highly supported (BS 100%, PP 1.00) and contained the *Ixora* group, the *Aleisanthia*–*Aleisanthiopsis* group, the *Greenea* group, exemplar Vanguerieae, and *Scyphiphora hydrophyllacea* C. F. Gaertn. (Fig. 2). The relationship between the *Greenea* group (A3) and the *Ixora*–*Aleisanthia*–*Aleisanthiopsis* clade (A1–A2) was strong (BS 100%, PP 1.00). In the combined parsimony analysis, *Scyphiphora* was resolved with poor support (BS less than 50%) as sister to a clade consisting of subclades A1, A2, and A3 (results not shown). Finally, clade B (Fig. 2) received high

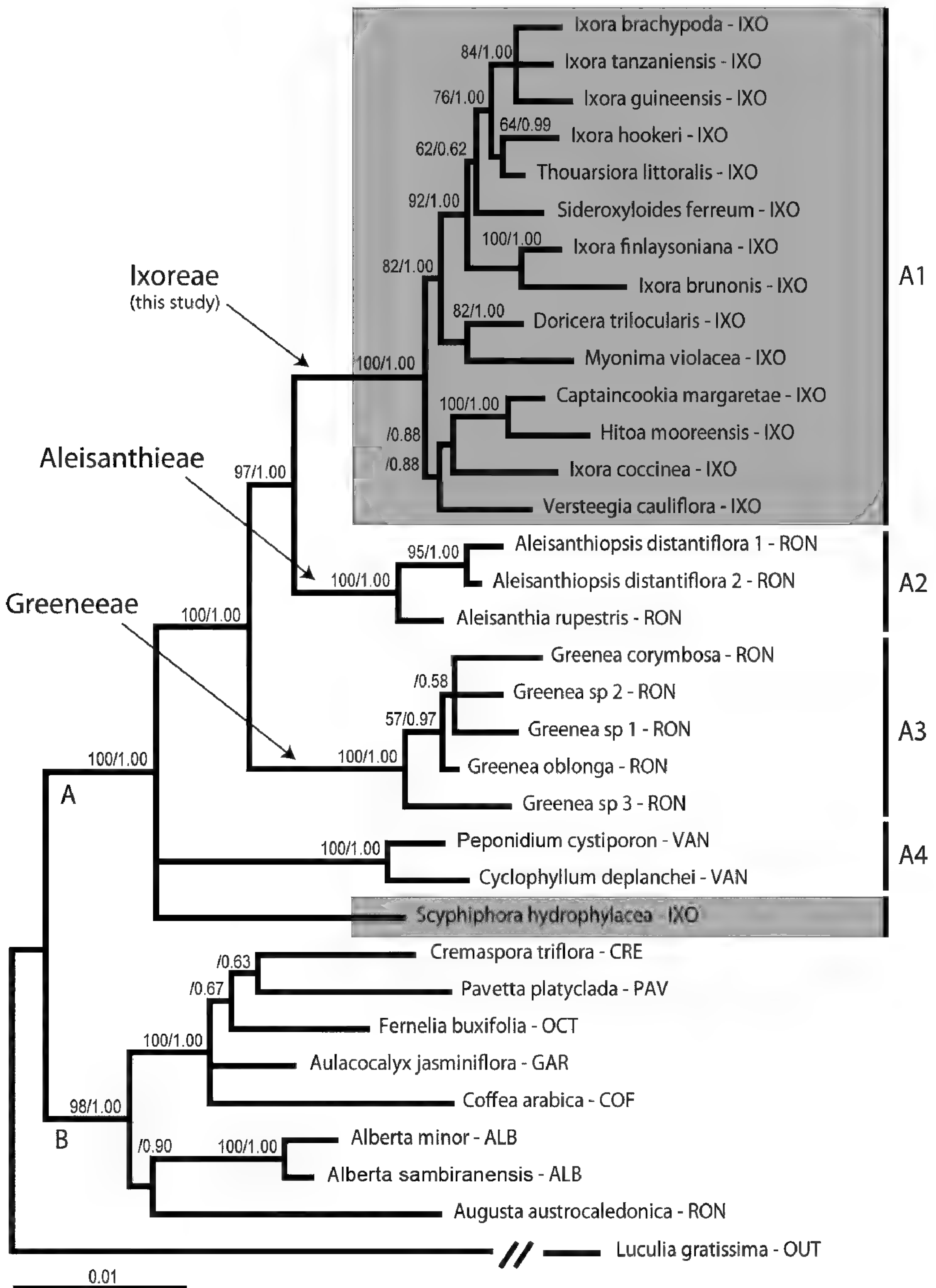

Figure 2. Majority consensus tree inferred from Bayesian analyses (2 M generations) of Ixoroideae generated from the combined chloroplast data sets. Numbers above nodes indicate bootstrap support from the parsimony analysis of identifiable nodes (left) and consensus of Bayesian posterior probabilities (right). Bootstrap values less than 50% or unresolved nodes are not indicated. The capital letters below the nodes indicate the main clades of the ingroup, and those on the right the terminal clades. Other groups representing recognized tribes of the Ixoroideae sensu Andreasen and Bremer (2000) are abbreviated as follows: ALB, Alberteae; COF, Coffeae; CRE, Cremasporeae; GAR, Gardenieae; IXO, Ixoreae; OCT, Octotropideae; PAV, Pavetteae; VAN, Vanguerieae. Species recently included to Ixoroideae from Rondeletieae are annotated RON. The outgroup is annotated OUT. Gray boxes represent the former delimitation of the tribe Ixoreae (sensu Andreasen & Bremer, 2000).

support (BS 98%, PP 1.00), while it was not always the case for its internal nodes.

DISCUSSION

First, we compare the sequence characteristics of our *rps16*, *rbcL*, and *trnT-F* data sets with those published for other Rubiaceae groups. Second, we discuss the paraphyly of *Ixora* and the competing circumscriptions of Ixoreae in light of the results of our phylogenetic analyses. Accordingly, a new tribal circumscription of Ixoreae and two new tribes are established.

SEQUENCE CHARACTERISTICS

Our conclusions on the circumscriptions of Ixoreae are based on the combined tree (Fig. 2), as it is the best-supported hypothesis. Most of the informative characters are localized in the *trnT-L* and *trnL-F* spacers rather than the *trnL* introns, consistent with Razafimandimbison and Bremer (2002) and Alejandro et al. (2005). However, many substitutions and most of the indels are within the relatively more conservative *trnL* introns and *rbcL* exon (Table 3); they appear as unambiguous synapomorphies for several clades. The *rbcL* data used in earlier studies about relationships within Rubiaceae are less informative than the *rps16* and *trnT-F* data, consistent with Razafimandimbison and Bremer (2001); *rbcL* sequence data are usually used for assessing interfamilial relationships (Chase et al., 1993; Clegg et al., 1994; Bremer et al., 2002; Shaw et al., 2005).

PARAPHYLY OF *IXORA*

The present analyses demonstrate that *Ixora* as presently delimited is paraphyletic, unless *Captaincookia*, *Doricera*, *Hitoea*, *Myonima*, *Thouarsiora*, and *Versteegia* are all included (Fig. 2). *Ixora coccinea* seems more closely related to *Captaincookia*, *Hitoea*, and *Versteegia* than it is to the six sequenced species of *Ixora*. Plus, *Doricera* and *Myonima* appear more closely related to the six sampled *Ixora* species than they are to *I. coccinea*. The inclusion of *Hitoea*, *Sideroxyloides*, and *Thouarsiora* with *Ixora* is supported by our studies. On the other hand, very few distinctive morphological features distinguish *Ixora* from its allied genera, such as hypocateriform versus infundibuliform corollas and soft versus bony fruits (Bridson & Robbrecht, 1985). With respect to *Ixora*, problematic generic circumscriptions were already observed in Rubiaceae, especially among large genera (e.g., *Psychotria* L., *Galium* L., *Oldenlandia* L.). Phylogenetic analyses based on multiple nuclear

and chloroplast markers and a much larger sampling of *Ixora* and affined taxa are being undertaken to specifically address the generic limits of *Ixora*.

CIRCUMSCRIPTION OF IXOREAE

The results of the present study do not support the two recently suggested circumscriptions of Ixoreae. Ixoreae sensu Andreasen and Bremer (2000) is not monophyletic, unless *Scyphiphora* is excluded and *Captaincookia*, *Doricera*, *Myonima*, and *Versteegia* are included. Ixoreae sensu Robbrecht and Manen (2006) is polyphyletic, as it includes *Scyphiphora* and does not comprise both *Captaincookia* and *Doricera*. Our analyses further corroborate the exclusion of the monotypic *Captaincookia* and *Doricera* from Pavetteae sensu Andreasen and Bremer (2000), represented here by *Pavetta platyclada* K. Schum. & Lauterb., and support the inclusion of the former two genera in a broadly circumscribed Ixoreae. The phylogenetic position of *Aleisanthia*, *Aleisanthiopsis*, and *Greenea* within the Ixoroideae, as revealed by Rova et al. (2002), and its close relationship with *Ixora* s.l., is also corroborated by our results (Fig. 2).

The phylogeny (Fig. 2) clearly shows that Ixoreae needs a new circumscription. Whether Ixoreae should be recognized in a narrow sense (i.e., including only *Ixora* s.l.) or in a broad sense (i.e., *Ixora* s.l. plus *Aleisanthia*, *Aleisanthiopsis*, and *Greenea*) is a matter of taxonomic judgment. Recognizing Ixoreae in a narrow sense would force us to raise both the *Aleisanthia*–*Aleisanthiopsis* and *Greenea* groups to the tribal level. This would make Ixoreae s. str. homogeneous morphologically (Table 4) but cause nomenclatural novelties. In contrast, one may propose a broad circumscription of Ixoreae (including genera of subclades A1 to A3 in Fig. 2), which requires no nomenclatural changes but perhaps necessitates descriptions of three new subtribal taxa. However, merging *Aleisanthia*, *Aleisanthiopsis*, and *Greenea* in Ixoreae would make the tribe morphologically heterogeneous (Table 4) and diagnosable only by its aestivation contorted to the left (Robbrecht & Manen, 2006) and its lack of raphides, two features commonly found throughout the Ixoroideae. We favor a narrow and well-defined circumscription of Ixoreae, which contains the following eight genera of subclade A1 (Fig. 2): *Captaincookia*, *Doricera*, *Hitoea*, *Ixora* (as polyphyletic), *Myonima*, *Sideroxyloides*, *Thouarsiora*, and *Versteegia*. Accordingly, we recognize both the distinctive *Aleisanthia*–*Aleisanthiopsis* (subclade A2) and *Greenea* (subclade A3) at the tribal level.

Ixoreae s. str. (e.g., subclade A1, Fig. 2) can easily be diagnosed by its articulated petioles, 4-merous flowers, corolla contorted to the left in bud, exerted

Table 3. Unambiguous molecular synapomorphies for recognized tribal and generic lineages.

Lineages	No. of synapomorphic substitutions	Synapomorphic insertions	Synapomorphic deletions
Ixoreae	<i>trnT-L</i> (spacer): 1 <i>trnL-F</i> (introns): 6 <i>rbcL</i> (exon): 3	<i>rps16</i> (intron): CTAAA	<i>trnT-L</i> (spacer): T
Aleisanthieae	<i>trnL-F</i> (intron): 2	<i>trnT-L</i> (spacer): CATAATCATATATTTCTA <i>trnL-F</i> (introns): CTTTTAATIG	
Greeneeae	<i>trnT-L</i> (spacer): 2 <i>trnL-F</i> (introns): 5 <i>rps16</i> (intron): 4 <i>rbcL</i> (exon): 3	<i>rps16</i> (intron): T	<i>trnT-L</i> (spacer): GTATA <i>trnL-F</i> (introns): CAAAA <i>rps16</i> (intron): TTTTAT
<i>Scyphiphora</i>	<i>trnT-L</i> (spacer): 7 <i>trnL-F</i> (introns): 10 <i>rps16</i> (intron): 5	<i>trnT-L</i> (spacer): AAATA; T; T; TTTT <i>trnL-F</i> (introns): GAAAATAT; T	<i>trnT-L</i> (spacer): A; A <i>trnL-F</i> (introns): TTAATGA; ATTCATTTAT <i>rps16</i> (intron): T

stamens, drupaceous fruits and uniovular locules, sclerified endocarp, and entire endosperm (Bremekamp, 1934, 1937; De Block, 1997; Andreasen & Bremer, 2000; Table 4). The *Aleisanthia*–*Aleisanthiopsis* group (as “Aleisanthieae”; subclade A2, Fig. 2) is a well-defined clade that can be diagnosed by the woolly hairs on the abaxial leaf surface, scorpioid inflorescences, infundibuliform corollas, inserted stamens, multiovulate ovaries, and capsular fruits (Tange, 1996a, b; Table 4). Similarly, *Greenea* (as “Greeneeae”; subclade A3, Fig. 2) can be distinguished from Ixoreae and the *Aleisanthia*–*Aleisanthiopsis* group by protogyny, flowers without an obvious calyx tube, simply consisting of minute triangular free lobes (Puff et al., 2005; Table 4) and the lack of secondary pollen presentation (Tange, 1996b).

SCYPHIPHORA

We find no support for the phylogenetic placement of *Scyphiphora* as sister to *Ixora* s. str. shown by Andreasen and Bremer (2000). Its position in Ixoreae sensu Robbrecht and Manen (2006) is not corroborated by our results, as it is placed in an unresolved trichotomy with Ixoreae s.l. and Vanguerieae within clade A (Fig. 2). For now, *Scyphiphora* should be considered to be unplaced but close to Ixoreae, Aleisanthieae, Greeneeae, and Vanguerieae. Few distinct morphological features separate *Scyphiphora* from the taxa in clade A (Fig. 2, Table 4). The presence of two ovules per locule (Baillon, 1880; Puff & Rohrhofer, 1993) in *Scyphiphora* is a rather unusual feature within this clade A, as well as within Rubiaceae. Furthermore, fibrous and very thick pyrenes are also rare and probably represent an adaptation to sea dispersal, as *S. hydrophylacea* is

restricted to mangrove habitats. The genus has contorted aestivation like Ixoreae (as here delimited), Aleisanthieae, and Greeneeae, whereas Vanguerieae representatives (subclade A4, Fig. 2) have valvate aestivation. Conversely, *Scyphiphora* resembles Vanguerieae (and *Aleisanthia*) in its axillary inflorescences. Despite its supported position within clade A (Fig. 2), *Scyphiphora* remains both unresolved from molecular data and ambiguous in its putative affinities within clade A tribes according to morphology.

TAXONOMIC SYNOPSIS

The tribal concept of Ixoreae is better understood with results from molecular phylogenetic analyses. Bentham (1849) used the name Ixoreae first but only provisionally (Darwin, 1976: 603). The current use of the name correctly attributes Ixoreae to Gray (1858). The following treatment presents an emended description of Ixoreae and recognition of two new tribes (for *Aleisanthia*–*Aleisanthiopsis* and for *Greenea*) for which no names are available.

- Ixoreae** A. Gray., Proc. Amer. Acad. Arts 4: 39. 1858, non Ixoreae Griseb., nom. illeg., p.p., Fl. Brit. India 1: 337. 1861, as subtribe [including *Coffea*], nec Ixoreae Hook. f., nom. illeg., p.p., Gen. Pl., 2: 9, 22. 1873, as tribe [including *Coffea*], nec Ixoreae K. Schum., nom. illeg., p.p., Nat. Pflanzenfam. 4: 1891; as tribe [including *Coffea* and *Pavetta*]. TYPE: *Ixora* L.

Coffeae DC. p.p., Ann. Mus. Natl. Hist. Nat. 9: 217. 1807, as tribe.

Pavetteae A. Rich. ex Dumort. p.p., Anal. Fam. Pl.: 33. 1829, as tribe.

Table 4. Summary of selected morphological characters relevant to Ixoreae alliance as presently circumscribed. Unambiguous morphological features that characterize the recognized tribes and *Scyphiphora* within the main clade A of Figure 2 are in boldface.

	Ixoreae	Aleisanthieae	Greeneeae	Vanguerieae	<i>Scyphiphora</i>
Woolly hairs	absent	present	absent	absent	absent
Petioles	articulate	not articulate	not articulate	not articulate	articulate
Domatia	absent	present	present	present	absent
Inflorescence position	terminal/cauliflorous	terminal/axillary	terminal	axillary	axillary
Inflorescence type	cymose	scorpioid	scorpioid	cymose	cymose
Flowers	4-merous	5-merous	5-merous	4- to 5-merous	4-merous
Corolla aestivation	contorted	contorted	contorted	valvate	contorted
Calyx tube	present	present	absent	present	present
Stamens	exserted	inserted	inserted	inserted/exserted	exserted
Ovule numbers	1-ovule/carpel	many ovules/carpel	many ovules/carpel	1-ovule/carpel	2-ovules/carpel
Fruits	drupaceous	capsular	capsular	drupaceous	drupaceous
Sclerified endocarps	present	absent	absent	present	present
Dispersal mode	zoochorous	anemochorous	anemochorous	zoochorous	sea currents
Secondary pollen presentation	present	present	absent	present	present
Pollen grains	colporate	pororate/colporate	colporate	po(ro)rate	colporate
Sexuality	protandrous	protandrous	protogynous	protandrous	protandrous

Ixoreae representatives are easily distinguishable by the following combination of characters: leaf petiole articulate; inflorescences as small to large cymes, terminal (sometimes on brachyblasts or cauliflorous); flowers 4-merous, protandrous; aestivation contorted to the left; corolla hypocrotiferiform (*Captaincookia* excepted); stamens exserted; secondary pollen presentation; ovary 2(to 7)-locular; locule uniovulate; fruit drupaceous, 2(to 7)-locular; pyrene leathery to crustaceous; seed with circular adaxial excavation extending into a basal groove; endosperm entire.

Included genera: *Becheria*, *Bemsetia*, *Captaincookia*, *Doricera*, *Hitoa*, *Ixora*, *Myonima*, *Patabea*, *Sideroxyloides*, *Thouarsiora*, *Versteegia*.

Ixoreae (subclade A1, Fig. 2) as presently circumscribed is supported by several unambiguous synapomorphies among three chloroplast markers (e.g., Table 3) and a homogeneous morphology. The following genera are currently recognized as *Ixora* synonyms: *Becheria*, *Bemsetia*, *Hitoa*, *Patabea*, *Sideroxyloides*, *Thouarsiora*, but the paraphyly of *Ixora* questions generic circumscriptions within Ixoreae.

2. Aleisanthieae Mouly, J. Florence & B. Bremer, tribus nov. TYPE: *Aleisanthia* Ridl.

Tribus nova quae ab Ixoreis A. Gray lamina foliari subtus plerumque omnino lanosa, inflorescentia scorpioidea, floribus pentameris atque ovarii loculis multiovulatis praecipue differt.

Aleisanthieae is distinguished by the following combination of characters: blades covered with woolly

hairs on the abaxial leaf surface; inflorescence scorpioid, axillary or terminal; flowers 5-merous, small, protandrous; calyx lobes small and triangular to rounded; aestivation contorted to the left; corolla infundibuliform; stamens included; secondary pollen presentation; ovary 2-locular, multiovulate; fruit capsular.

Included genera: *Aleisanthia*, *Aleisanthiopsis*, *Greeniopsis* Merr.

The Aleisanthieae clade comprises the two South-east Asian genera *Aleisanthia* and *Aleisanthiopsis* and is resolved as sister to the pantropical Ixoreae s. str. Aleisanthieae is well supported by unambiguous molecular evidence, with synapomorphic substitutions and indels (Table 3). The woolly hairs on the abaxial leaf surface (Table 4) represent a rare feature in Ixoroideae and may be regarded as a synapomorphy of the Aleisanthieae. Tange (1996b) also associated the Philippine genus *Greeniopsis* (Merrill, 1909), with seven species, with *Aleisanthia* and *Aleisanthiopsis*, but reported no presence of woolly hairs on the leaves. However, *G. discolor* Merr. does possess these typical hairs (Mouly, pers. obs.). In the genera *Aleisanthia* and *Greeniopsis*, styler complexes are observed, similar to those described in Vanguerieae (Igersheim, 1993; Lantz et al., 2002), but these were not observed in *Aleisanthiopsis distantiflora* (Merr.) Tange (Tange, 1996b). The pollen grains are 3-pororate in *Aleisanthia* and *Greeniopsis*, although the pollen stains in *Aleisanthiopsis* are 3-colporate. Inflorescences are axillary in *Aleisanthia* but are terminal in *Aleisanthiopsis* and *Greeniopsis*. Our tentative placement of *Greeniopsis* in

Aleisanthieae based on morphological resemblance needs to be confirmed from molecular data.

3. Greeneae Mouly, J. Florence & B. Bremer, tribus nov. TYPE: *Greenea* Wight & Arn.

Tribus nova quae ab Aleisanthieis floribus proterogynis, calyce sine tubo manifesto atque stigmatibus linearibus sine pollinis praesentatione secundaria praecipue differt.

The tribe Greeneae is characterized by the following combination of characters: leaves without abaxial woolly hairs (but rarely glabrous); inflorescence terminal, scorpioid; flowers 5-merous, small, protogynous; calyx without obvious tube; aestivation contorted to the left; corolla infundibuliform to campanulate; stamens included; primary pollen presentation; ovary 2-locular, multiovulate; fruit capsular.

Included genera: *Greenea*, *Spathichlamys* R. Parker.

The absence of secondary pollen presentation in *Greenea* (Tange, 1996b) is uncommon within the studied lineage (clade A, Fig. 2). Furthermore, the protogyny of the *Greenea* species is also unique: the stigmatic lobes are partially to completely exerted and opened at the latest bud stage, while anthers are accessible to pollinators only after opening and enlargement of the corolla tube. Otherwise, in all species with secondary pollen presentation, an initial functionally male stage precedes the functionally female stage during anthesis (Nilsson et al., 1990; Puff et al., 1996). The disappearance of secondary pollen presentation might be linked to the adaptation to protogyny. Greeneae is supported by many unambiguous molecular synapomorphies (see Table 3). The species *G. commersonii* (Korth.) Boerl. (Boerlage, 1891), previously described in the genus *Rhombospora* Korth. (Korthals, 1850), also shares the diagnostic morphological features of *Greenea*, but was not investigated. The monotypic Indonesian genus *Spathichlamys* (Parker, 1931; Ridsdale, 1982; Tange, 1996b) is identical morphologically to *Greenea* from which it differs only by the corolla that splits and rolls up at anthesis (Ridsdale, 1982).

CONCLUSIONS

The present study clearly shows that *Ixora* as currently delimited is paraphyletic and Ixoreae sensu Andreasen and Bremer (2000) and sensu Robbrecht and Manen (2006) are non-monophyletic. The monophyly of a broadly circumscribed and morphologically heterogeneous Ixoreae alliance (including *Ixora*, *Captaincookia*, *Doricera*, *Hitoa*, *Myonima*, *Sideroxyloides*, *Thouarsiora*, *Versteegia*, plus *Aleisanthia*, *Aleisanthiopsis*, and *Greenea*) is strongly supported. In order to recognize monophyletic and morphologi-

cally consistent groups, we adopt a narrowly circumscribed Ixoreae (including *Becheria*, *Bemsetia*, *Captaincookia*, *Doricera*, *Hitoa*, the paraphyletic *Ixora*, *Myonima*, *Patabea*, *Sideroxyloides*, *Thouarsiora*, and *Versteegia*) and erect the *Aleisanthia*–*Aleisanthiopsis* and *Greenea* groups at tribal level, Aleisanthieae and Greeneae, respectively. Finally, the Malesian Aleisanthieae and the pantropical Ixoreae s. str. are sister groups and the Southeast Asian Greeneae is sister to the Ixoreae–Aleisanthieae clade.

Literature Cited

- Akaike, H. 1974. A new look at the statistical model identification. *IEEE Trans. Automat. Contr.* AC-19: 716–723.
- Alejandro, G. D., S. G. Razafimandimbison & S. Liedes-Schumann. 2005. Polyphyly of *Mussaenda* inferred from ITS and *trnT-F* data and its implication for generic limits in Mussaendeae (Rubiaceae). *Amer. J. Bot.* 92: 544–557.
- Andreasen, K. & B. Bremer. 1996. Phylogeny of the subfamily Ixoroideae (Rubiaceae). *Opera Bot. Belg.* 7: 119–138.
- & ———. 2000. Combined phylogenetic analysis in the Rubiaceae-Ixoroideae: Morphology, nuclear and chloroplast DNA data. *Amer. J. Bot.* 87: 1731–1748.
- Arènes, J. 1960. A propos de quelques genres Malgaches de Rubiacées. *Not. Syst. (Paris)* 16: 6–19.
- Aublet, F. 1775. *Histoire des plantes de la Guiane Française, rangées suivant la méthode sexuelle, avec plusieurs mémoires sur différens objets intéressans, relatifs à la culture & au commerce de la Guiane Française, & une notice des plantes d'Île-de-France, Vol. 1.* Pierre-François Didot jeune, Librairie de la Faculté de Médecine, Londres & Paris.
- Baillon, H. N. 1879. Sur les limites du genre *Ixora*. *Adansonia* 12: 213–219.
- . 1880. Sur l'organisation des *Scyphiphora*. *Bull. Mens. Soc. Linn. Paris* 1: 174–175.
- Beauvisage, G. 1901. *Genera Montrouzierana, plantarum Novae Caledoniae.* Librairie J.-B. Baillièrre & fils, Paris.
- Bentham, G. 1849. Rubiaceae. Pp. 377–425 in W. J. Hooker (editor), *Niger Flora.* Hippolyte Baillièrre, London.
- . 1850. *Plantae regnellianae—Rubiaceae.* *Linnaea* 23: 443–466.
- Boerlage, J. G. 1891. Fam. LXVIII. Rubiaceae. Pp. 7–144 in J. G. Boerlage (editor), *Handleiding tot de Kennis der Flora van nederlandsch Indië. Beschrijving van de Families en Geslachten der nederl. Indische Phanerogamen. Tweede deel. Dicotyledones gamopetalae. Eerste stuk. Inferae—Heteromerae.* E. J. Brill, Leiden.
- Bremekamp, C. E. B. 1934. A monograph of the genus *Pavetta* L. *Rep. Spec. Nov. Regni Veg.* 37: 1–208.
- . 1937. The Malesian species of the genus *Ixora* (Rub.). *Bull. Jard. Bot. Buitenzorg, Sér. 3,* 14: 197–367.
- Bremer, B., R. K. Jansen, B. Oxelman, M. Backlund, H. Lantz & K.-J. Kim. 1999. More characters or more taxa for a robust phylogeny in a case study from the Coffee family (Rubiaceae). *Syst. Bot.* 48: 413–435.
- , K. Bremer, N. Heidari, P. Erixon, R. G. Olmstead, A. A. Anderberg, M. Källersjö & E. Barkhordarian. 2002. Phylogenetics of asterids based on 3 coding and 3 non-coding chloroplast DNA markers and the utility of non-coding DNA at higher taxonomic levels. *Molec. Phylogenet. Evol.* 24: 274–301.

- Bridson, D. M. 2000. The identity of *Tsiangia* (Rubiaceae). *Kew Bull.* 55: 1011–1012.
- & E. Robbrecht. 1985. Further notes on the tribe Pavetteae (Rubiaceae). *Bull. Jard. Bot. Natl. Belg.* 55: 83–115.
- But, P., H. H. Hsue & P. T. Li. 1986. *Tsiangia*, a new genus based on *Gaertnera hongkongensis* (Rubiaceae). *Blumea* 31: 311–312.
- Chase, M. W. & H. Hillis. 1991. Silica gel: An ideal material for field preservation of leaf samples for DNA studies. *Taxon* 40: 215–220.
- , D. E. Soltis, R. G. Olmstead, D. Morgan, D. H. Les, B. D. Mishler, M. R. Duvall, R. A. Price, H. G. Hills, Y.-L. Qiu, K. A. Kron, J. H. Rettig, E. Conti, J. D. Palmer, J. R. Manhart, K. J. Sytsma, H. J. Michaels, W. J. Kress, K. G. Karol, W. D. Clark, M. Hedrén, B. S. Gaut, R. K. Jansen, K.-J. Kim, C. F. Wimpee, J. F. Smith, G. R. Furnier, S. H. Strauss, Q.-Y. Xiang, G. M. Plunkett, P. S. Soltis, S. M. Swensen, S. E. Williams, P. A. Gadek, C. J. Quinn, L. E. Eguiarte, E. Golenberg, G. H. Learn Jr., S. W. Graham, S. C. H. Barrett, S. Dayanandan & V. A. Albert. 1993. Phylogenetics of seed plants: An analysis of nucleotide sequences from the plastid gene *rbcL*. *Ann. Missouri Bot. Gard.* 80: 528–580.
- Clegg, M. T., B. S. Gaut, G. H. Learn Jr. & B. R. Morton. 1994. Rates and patterns of chloroplast DNA evolution. *Proc. Natl. Acad. Sci. U.S.A.* 91: 6795–6801.
- Cunningham, C. W. 1997. Can three incongruence tests predict when data should be combined? *Molec. Biol. Evol.* 14: 733–740.
- Darlu, P. & G. Lecointre. 2002. When does the incongruence length difference test fail? *Molec. Biol. Evol.* 19: 432–437.
- Darwin, S. P. 1976. The subfamilial, tribal, and subtribal nomenclature of the Rubiaceae. *Taxon* 25: 595–610.
- . 1979. A synopsis of the indigenous genera of Pacific Rubiaceae. *Allertonia* 2: 1–44.
- De Block, P. 1997. Biosystematic Studies in the Tribe Pavetteae (Rubiaceae–Ixoroideae). Ph.D. Thesis, Universiteit Antwerpen, Antwerp.
- . 1998. The African species of *Ixora* (Rubiaceae–Pavetteae). *Opera Bot. Belg.* 9: 1–218.
- Delarbre, C., H. Escriva, C. Gallut, V. Barriol, P. Kourilsky, P. Janvier, V. Laudet & G. Gachelin. 2000. The complete nucleotide sequence of mitochondrial DNA of the agnathan *Lampetra fluviatilis*: Bearings on the phylogeny of cyclostomes. *Molec. Biol. Evol.* 17: 519–529.
- Doyle, J. J. & J. L. Doyle. 1987. A rapid DNA isolation procedure for small quantities of fresh leaf tissue. *Phytochem. Bull.* 19: 11–15.
- Dumortier, B. C. J. 1829. Analyse des familles de plantes, avec l'indication des principaux genres qui s'y rattachent. Casterman, Tournay, France.
- Farris, J. S. 1989. The retention index and the rescaled consistency index. *Cladistics* 5: 417–419.
- , M. Källersjö, A. G. Kluge & C. Bult. 1994. Testing significance of incongruence. *Cladistics* 10: 315–319.
- Felsenstein, J. 1985. Confidence limits on phylogenies: An approach using the bootstrap. *Evolution* 39: 783–791.
- Fosberg, F. R. 1937. Some Rubiaceae of Southeastern Polynesia. *Occas. Pap. Bernice Pauahi Bishop Mus.* 13: 245–293.
- Freudenstein, J. V. & M. W. Chase. 2001. Analysis of mitochondrial nad1b-c intron sequences in Orchidaceae: Utility and coding of length-change characters. *Syst. Bot.* 26: 643–657.
- Gaertner, C. F. 1806. Supplementum carpologiae (seu continuati operas Josephi Gaertner de Fructibus et Seminibus Plantarum 3). Richter, Leipzig.
- Giribet, G. & W. C. Wheeler. 1999. On gaps. *Molec. Phylogenet. Evol.* 13: 132–143.
- Gray, A. 1858. Notes upon some Rubiaceae, collected in the United States South Sea Exploring Expedition under Captain Wilkes, with characters of new species. 3. Ixoreae. *Proc. Amer. Acad. Arts* 4: 39–40.
- Guédès, M. 1986. *Ixoras* malgaches nouveaux à fleurs solitaires. *Phytologia* 60: 243–250.
- Hallé, N. 1973. *Captaincookia*, genre nouveau monotypique néocalédonien de Rubiaceae–Ixoreae. *Adansonia, Sér.* 2 13: 195–202.
- Hooker, J. D. 1873. Ordo LXXXIV. Rubiaceae. Pp. 7–151 in G. Bentham & J. D. Hooker (editors), *Genera plantarum ad exemplaria imprimis in herbariis kewensibus servata defirmata*, Vol. 2. Reeve & Co., London.
- Huelsenbeck, J. P. & F. Ronquist. 2001. MrBayes: Bayesian inference of phylogenetic trees. *Bioinformatics* 17: 754–755.
- , B. Larget, R. E. Miller & F. Ronquist. 2002. Potential applications and pitfalls of Bayesian inference of phylogeny. *Syst. Biol.* 51: 673–688.
- Igersheim, A. 1993. Gynoecium development in Rubiaceae–Vanguerieae, with particular reference to the “stylar head”–complex and secondary pollen presentation. *Pl. Syst. Evol.* 187: 175–190.
- Jacquin, N. J. 1763. *Selectarum Stirpium Americanarum Historia*. A. Blumauer, Vienna.
- Jussieu, A. L. 1789. *Genera plantarum secundum ordines naturales disposita*. Herissant & Barrois, Paris.
- Kluge, A. & J. S. Farris. 1969. Quantitative phyletics and the evolution of anurans. *Syst. Zool.* 18: 1–32.
- Korthals, P. W. 1850. *Overzicht der Rubiaceën van de Nederlansch-Oostindische Kolonien*. *Ned. Kruidk. Arch.* 2: 145–269.
- Lantz, H., K. Andreasen & B. Bremer. 2002. Nuclear rDNA ITS sequence data used to construct the first phylogeny of Vanguerieae (Rubiaceae). *Pl. Syst. Evol.* 230: 173–187.
- & B. Bremer. 2004. Phylogeny inferred from morphology and DNA data: Characterizing well-supported groups in Vanguerieae (Rubiaceae). *Bot. J. Linn. Soc.* 146: 257–283.
- Lloyd, D. G. & V. L. Calder. 1991. Multi-residue gaps, a class of molecular character with exceptional reliability for phylogenetic analyses. *J. Evol. Biol.* 4: 9–21.
- Merrill, E. D. 1909. New or noteworthy Philippine plants. VII. *Philip. J. Sci.* 4: 247–330.
- Montrouzier, X. 1860. *Flore de l'Île Art (près de Nouvelle-Calédonie)*. *Mém. Acad. Roy. Sci. Lyon, Sect. Lett.* 10: 173–254.
- Mouly, A. 2007. *Systématique de la Tribu des Ixoreae A. Gray (Rubiaceae): Phylogénie, Biogéographie et Taxonomie*. Ph.D. Thesis, Muséum National d'Histoire Naturelle, Paris.
- Nadeaud, J. 1899. *Plantes nouvelles des Îles de la Société*. *J. Bot. (Morot)* 13: 1–8.
- Nilsson, L. A., E. Rabakonandrianina, B. Pettersson & J. Ranaivo. 1990. “Ixoroid” secondary pollen presentation and pollination by small moths in the Malagasy treelet *Ixora platythyrsa* (Rubiaceae). *Pl. Syst. Evol.* 170: 161–165.
- Nylander, J. A. A. 2004. MrModeltest 2.0. Program distributed by the author. Evolutionary Biology Centre, Uppsala University, Uppsala.
- Olmstead, R. G., H. J. Michaels, K. M. Scott & J. D. Palmer. 1992. Monophyly of the Asteridae and identification of their major lineages inferred from DNA sequences of *rbcL*. *Ann. Missouri Bot. Gard.* 79: 249–265.

- Oxelman, B., M. Lidén & D. Berglund. 1997. Chloroplast *rps16* intron phylogeny of the tribe Sileneae (Caryophyllaceae). *Pl. Syst. Evol.* 206: 393–410.
- Parker, R. N. 1931. VII. Decades Kewenses. *Plantarum novarum in herbario regii conservatarum. Decas CXXV. 1244. Spathichlamys.* *Bull. Misc. Inform. Kew* 1931: 42–43.
- Puff, C., K. Chayamarit & V. Chamchumroon. 2005. Rubiaceae of Thailand—A Pictorial Guide to Indigenous and Cultivated Genera. The Forest Herbarium, National Park, Wildlife and Plant Conservation Department, Bangkok.
- , E. Robbrecht, R. Buchner & P. De Block. 1996. A survey of secondary pollen presentation in the Rubiaceae. *Opera Bot. Belg.* 7: 369–402.
- & U. Rohrhofer. 1993. The character states and taxonomic position of the monotypic mangrove genus *Scyphiphora* (Rubiaceae). Pp. 143–172 in E. Robbrecht (editor), *Advances in Rubiaceae Macro-systematics*. *Opera Bot. Belg.* Vol. 6. National Botanic Garden of Belgium, Meise.
- Rafinesque, C. S. 1838. *Sylva Telluriana, mantissa synoptica, new genera and species, of trees and shrubs of North America, and other regions of the Earth, omitted or mistaken by botanical authors and compilers, or not properly classified, now reduced by their natural affinities to the proper natural orders and tribes, Vol. 3.* C. S. Rafinesque, Philadelphia.
- Rambaut, A. 1996. Se-AL, version 1.0. Sequence alignment program. <<http://tree.bio.ed.ac.uk/software/seal/>>, accessed 6 January 2009.
- Razafimandimbison, S. G. & B. Bremer. 2001 [2002]. Tribal delimitation of Naucleaeae (Rubiaceae): Inference from molecular and morphological data. *Syst. Geogr. Pl.* 71: 515–538.
- & ———. 2002. Phylogeny and classification of Naucleaeae s.l. (Rubiaceae) inferred from molecular (ITS, *rbcL* and *trnT-F*) and morphological data. *Amer. J. Bot.* 89: 1027–1041.
- Richard, A. 1829. *Mémoire sur la famille des Rubiacées, contenant les caractères des genres de cette famille et d'un grand nombre d'espèces nouvelles.* Tastu, Paris.
- Ridley, H. N. 1912. New and rare Malayan plants (series VI). *J. Straits Branch Roy. Asiat. Soc.* 61: 1–43.
- . 1920. New and rare plants from the Malay Peninsula. *J. Fed. Malay States Mus.* 10: 128–156.
- Ridsdale, C. E. 1982. *Spathichlamys*—A remarkable Rubiaceae. *Blumea* 28: 143–144.
- Robbrecht, E. 1988. Tropical woody Rubiaceae: Characteristic features and progressions. *Contributions to a new subfamilial classification.* *Opera Bot. Belg.* 1: 1–271.
- & J.-F. Manen. 2006. The major evolutionary lineages of the coffee family (Rubiaceae, angiosperms): Combined analysis (nDNA and cpDNA) to infer the position of *Coptosapelta* and *Luculia*, and supertree construction based on *rbcL*, *rps16*, *trnL-trnF* and *atpB-rbcL* data. A new classification in two subfamilies, Cinchonoideae and Rubioideae. *Syst. Geogr. Pl.* 76: 85–146.
- Rouhan, G., J.-Y. Dubuisson, F. Rakotondrainibe, T. J. Motley, J. T. Mickel, J.-N. Labat & R. C. Moran. 2004. Molecular phylogeny of the fern genus *Elaphoglossum* (Elaphoglossaceae) based on chloroplast non-coding DNA sequences: Contributions of species from the Indian Ocean area. *Molec. Phylogenet. Evol.* 33: 745–763.
- Rova, J. H. E., P. G. Delprete, L. Andersson & V. A. Albert. 2002. A *trnL-F* cpDNA sequence study of the Condamineae-Rondeletieae-Sipaneeae complex with implications on the phylogeny of Rubiaceae. *Amer. J. Bot.* 89: 145–159.
- Saghai-Marouf, K., M. Soliman, R. A. Jorgensen & R. W. Allard. 1984. Ribosomal DNA spacer length polymorphism in barley: Mendelian inheritance, chromosomal location, and population dynamics. *Proc. Natl. Acad. Sci. U.S.A.* 81: 8014–8018.
- Sandwith, N. Y. 1937. Contributions to the flora of tropical America: XXX. New species and records from British Guiana. *Bull. Misc. Inform. Kew* 1937: 100–112.
- Shaw, J., E. B. Lickey, J. T. Beck, S. B. Farmer, W. Liu, J. Miller, K. C. Siripun, C. T. Winder, E. E. Schilling & R. L. Small. 2005. The tortoise and the hare II: Relative utility of 21 noncoding chloroplast DNA sequences for phylogenetic analysis. *Amer. J. Bot.* 92: 142–166.
- Smith, A. C. & S. P. Darwin. 1988. Family 168. Rubiaceae. Pp. 143–362 in A. C. Smith (editor), *Flora Vitiensis Nova, A New Flora of Fiji (Spermatophytes Only), Vol. 4.* Pacific Tropical Botanical Garden, Lawai, Kauai, Hawaii.
- Staden, R. 1996. The Staden sequence analysis package. *Molec. Biotechnol.* 5: 233–241.
- Swofford, D. L. 1993. PAUP: Phylogenetic Analysis Using Parsimony, Vers. 3.1.1. Computer program distributed by the Illinois Natural History Survey, Champaign.
- . 2002. PAUP*: Phylogenetic Analysis Using Parsimony, Vers. 4.08b. Sinauer Associates, Sunderland, Massachusetts.
- Taberlet, P. L., L. Gielly, G. Patou & J. Bouvet. 1991. Universal primers for amplification of three non-coding regions of chloroplast DNA. *Pl. Molec. Biol.* 17: 1105–1109.
- Tange, C. 1996a [1997]. Studies in SE Asiatic Rondeletieae I: The West Malesian endemic genus *Aleisanthia* (Rubiaceae). *Nord. J. Bot.* 16: 563–570.
- . 1996b [1997]. Studies in SE Asiatic Rondeletieae II: *Aleisanthiopsis* (Rubiaceae), a new genus from Borneo. *Nord. J. Bot.* 16: 571–578.
- Valeton, T. 1911. Rubiaceae. Pp. 437–519 + illustrations in H. A. Lorenz (editor), *Résultats de l'expédition scientifique néerlandaise à la Nouvelle-Guinée en 1907 et 1909, Vol. 8, Botanique.* Librairie et Imprimerie Ci-Devant E. J. Brill, Leiden.
- van Dijk, M. A., E. Paradis, F. Catzeflis & W. W. De Jond. 1999. The virtues of gaps: Xenarthran (Edentate) monophyly supported by a unique deletion in alpha A-crystallin. *Syst. Biol.* 48: 94–106.
- Verdcourt, B. 1983. Notes on Mascarene Rubiaceae. *Kew Bull.* 37: 521–574.
- . 1989. 108. Rubiacées. Pp. 1–135 in J. Bosser, T. Cadet, J. Guého & W. Marais (editors), *Flore des Mascareignes, La Réunion, Maurice, Rodrigues.* M.S.I.R.I., O.R.S.T.O.M. & Kew, Port Louis, Mauritius.
- Vieillard, E. 1865. Plantes de la Nouvelle-Calédonie recueillies par M. Eugène Vieillard, chirurgien de la Marine. *Bull. Soc. Linn. Normandie* 9: 332–348.
- Wight, R. & G. A. W. Arnott. 1834. Order LXXXI.—Rubiaceae Juss. Pp. 390–443 in R. Wight & G. A. W. Arnott (editors), *Prodromus florae peninsulae Indiae orientalis: Containing abridged descriptions of the plants found in the peninsula of British India, arranged according to the natural system, Vol. 1.* Parbury, Allen & Co., London.
- Yang, Z. 1994. Maximum likelihood phylogenetic estimation from DNA sequences with variable rates over sites: Approximate methods. *J. Molec. Evol.* 39: 306–314.
- Yoder, A. D., J. A. Irwin & B. A. Payseur. 2001. Failure of the ILD to determine data compatibility for slow Loris phylogeny. *Syst. Biol.* 50: 408–424.

Appendix 1. Specimen vouchers, origin, and accession numbers of *rps1b*, *trnT-F*, and *rbcL* sequences used in molecular analyses. In the Voucher/Reference column, indications follow the appearance of genic regions when multiple, or refer to all genic regions when single. Herbarium acronyms are listed in parentheses after voucher information. Newly published sequences are annotated with an asterisk after GenBank accessions.

Species	Vouchers/References	Origins	Accession numbers <i>rps1b</i>	Accession numbers <i>trnT-F</i>	Accession numbers <i>rbcL</i>
Outgroup					
<i>Luculia gratissima</i> (Wall.) Sweet	CT 80064 (UPS)	unknown	EU817448*	EU817472*	EU817429*
Albeteae					
<i>Alberta minor</i> Baill.	Razafimandimbison S. G. 558 (UPS)	Madagascar	EF205637	EU817452*	EU817410*
<i>A. sambiranensis</i> Homolle ex Cavaco	Razafimandimbison S. G. 360 (UPS)	Madagascar	EF205645	EU817474*	EU817431*
Cremsporeae					
<i>CreMASpora triflora</i> K. Schum.	Persson, 2000; Persson, 2000; Andreassen & Bremer, 1996	unknown	AF200990	AF201040	Z68856
Coffeae					
<i>Coffea arabica</i> L.	Andersson & Rova, 1999; Struwe et al., 1998; Bremer et al., 1995	unknown	AF004038	AF102405	X83631
Gardenieae					
<i>Aulacocalyx jasminiflora</i> Hook. f.	Schmidt H. H. et al. 1672 (MO)	Ghana	EF205639	EU817455*	EU817413*
Ixoreae					
<i>Captaincookia margaritae</i> N. Hallé	Mouly A. & Innocente E. 267 (P)	New Caledonia	EU817436*	EU817456*	EU817415*
<i>Doricera trilocularis</i> (Balf. f.) Verdc.	Lesouef J. Y. 31 (TAN)	Mascarenes	EU817437*	EU817457*	EU817417*
<i>Hitoea moorensis</i> Nadeaud	Florence J. s.n. (P)	French Polynesia	EU817441*	EU817462*	EU817420*
<i>Ixora brachypoda</i> DC.	Bradley A. F., et al. 1022 (MO)	Gabon	EU817442*	EU817463*	EU817421*
<i>I. brunonis</i> Wall. ex G. Don	Larsen K. et al. 43463 (P)	Thailand	EU817446*	EU817470*	EU817427*
<i>I. coccinea</i> L.	Bremer B. 2719 (UPS); Bremer B. 2719 (UPS); Bremer B. 3104 (UPS)	cultivated in Stockholm, Sweden	EF205641	EU817464*	X83646
<i>I. finlaysoniana</i> Wall. ex G. Don	Luke Q. 9042 (UPS)	Kenya	EF205643	EU817466*	EU817423*
<i>I. guineensis</i> Benth.	Gereau R. E. et al. 5601 (MO)	Ghana	EU817443*	EU817467*	EU817424*
<i>I. hookeri</i> (Oudem.) Bremek.	Mouly A. & Florence J. 342 (P)	French Polynesia	EU817444*	EU817468*	EU817425*
<i>I. tanzaniensis</i> Bridson	Luke Q. 9304 (S)	Tanzania	EU817447*	EU817471*	EU817428*
<i>Myonima violacea</i> (Lam.) Verdc.	Lorence D. H. 1526 (P)	Mascarenes	EU817449*	EU817473*	EU817430*
<i>Scyphiphora hydrophyllacea</i> C. F. Gaertn.	Bremer K. et al. 95 (S)	Sri Lanka	EU817450*	EU817475*	EU817432*
<i>Sideroxyloides ferreum</i> Jacq.	Taylor C. 11693 (MO)	Caribbean	EF205642	EU817465*	EU817422*
<i>Thouarsiora littoralis</i> Homolle ex Arènes	McPherson G. & Rabenantoandro J. 18287 (MO)	Madagascar	EU817445*	EU817469*	EU817426*

Appendix 1. Continued.

Species	Vouchers/References	Origins	Accession numbers <i>rps16</i>	Accession numbers <i>trnT-F</i>	Accession numbers <i>rbcL</i>
<i>Versteegia cauliflora</i> Valetton	Drodz P. & Molem K. s.n. (UPS)	cultivated in Bogor, Indonesia	EU817451*	EU817476*	EU817433*
Octotropideae					
<i>Fernelia buxifolia</i> C. F. Gaertn.	Rova, unpubl.; –; Andreassen & Bremer, 2000	unknown	AF244892	–	AJ286704
Pavetteae					
<i>Pavetta platyclada</i> K. Schum. & Lauterb.	Drodz P. & Molem K. s.n. (UPS)	New Guinea	AJ320082	–	AJ318451
Rondeletieae					
<i>Aleisanthia rupestris</i> (Ridl.) Ridl.	Tange C. 45171 (AAU)	Malaysia	AF242902	AF152660	–
<i>Aleisanthiopsis distantiflora</i> (Merr.) Tange	accession 1: Kessler P. J. A. et al. 41 (P)	Borneo	EU817434*	EU817453*	EU817411*
<i>A. distantiflora</i>	accession 2: Tange C. 46977 (AAU)	Borneo	AF242903	AF152658	–
<i>Augusta austrocaledonica</i> (Brongn.) J. H. Kirkbr.	Mouly A. & Innocente E. 237 (P)	New Caledonia	EF205638	EU817454*	EU817412*
<i>Greenea corymbosa</i> (Jack) Voigt	Larsen K. et al. 44102 (AAU)	Thailand	AF242961	AF152657	–
<i>G. oblonga</i> Craib	Larsen K. & Larsen S. S. 33451 (P)	Thailand	EU817459*	EU817439*	–
<i>Greenea</i> sp. indet. 1	Larsen K. & Larsen S. S. 33378 (P)	Thailand	EU817440*	EU817461*	EU817419*
<i>Greenea</i> sp. indet. 2	Larsen K. et al. 43140 (P)	Thailand	–	EU817460*	EU817418*
<i>Greenea</i> sp. indet. 3	Beusekom C. F. van et al. 752 (P)	Thailand	EU817438*	EU817458*	–
Vanguerieae					
<i>Cyclophyllum deplanchei</i> Hook. f.	Mouly A. & Innocente E. 228 (P)	New Caledonia	EF205640	EF205631	EU817416*
<i>Peponidium cystiporon</i> (Byn. ex Cavaco) Razafim., Lantz & B. Bremer	Labat J.-N. et al. 3280 (P)	Comores	EU817435*	EF205629	EU817414*

EVOLUTIONARY TRENDS,
MAJOR LINEAGES, AND NEW
GENERIC LIMITS IN THE
DIOECIOUS GROUP OF THE
TRIBE VANGUERIEAE
(RUBIACEAE): INSIGHTS INTO
THE EVOLUTION OF
FUNCTIONAL DIOECY¹

Sylvain G. Razafimandimbison,² Henrik Lantz,³
Arnaud Mouly,² and Birgitta Bremer²

ABSTRACT

New generic circumscriptions of the Paleotropical tribe Vanguerieae in the subfamily Ixoroideae s.l. (Rubiaceae) have recently been established as a result of a series of phylogenetic studies conducted by Lantz and Bremer. The genus *Canthium* Lam. was shown in their study to be highly polyphyletic, and a largely dioecious group was for the first time identified within Vanguerieae. The dioecious group sensu Lantz and Bremer comprises about 140 species classified in eight genera: *Canthium* (*Canthium* subgen. *Bullockia* Bridson), *Dinocanthium* Bremek., *Leroya* Cavaco, *Neoleroya* Cavaco, *Peponidium* (Baill.) Arènes, *Pseudopeponidium* Homolles ex Arènes, *Pyrostria* Comm. ex Juss., and *Scyphochlamys* Balf. f. We sequenced 79 Vanguerieae taxa and performed phylogenetic analyses based on sequence data from two nuclear (ETS and ITS) markers to: (1) pinpoint the phylogenetic positions of the Comorean and Indian Ocean *Canthium* and the Southeast Asian *Canthium confertum* Korth. group in Vanguerieae; (2) evaluate the phylogenetic utility of three taxonomic characters (bract type, locule number, and fruit shape) previously and currently used for delimiting genera in the dioecious group; and (3) assess the evolution of functional dioecy in Vanguerieae. The results support a further disintegration of *Canthium* s.l., as the Comorean and Malagasy *Canthium* species are shown for the first time to be closely related to *Peponidium*. Similarly, *C. confertum* appears to have a close affinity with *Cyclophyllum* Hook. f. The combined analyses show that the dioecious group can be subdivided into four morphologically distinct clades formally recognized as genera: *Bullockia* (Bridson) Razafim., Lantz & B. Bremer, here elevated from *Canthium* subgen. *Bullockia* Bridson, as well as *Cyclophyllum*, *Peponidium* (including all Comorean, Malagasy, and Seychellean *Canthium* species), and *Pyrostria* (including *Dinocanthium*, *Leroya*, *Neoleroya*, *Pseudopeponidium*, and *Scyphochlamys*). All described species of *Canthium* subgen. *Bullockia* are transferred to *Bullockia*: *B. dyscriton* (Bullock) Razafim., Lantz & B. Bremer, *B. fadenii* (Bridson) Razafim., Lantz & B. Bremer, *B. impressinervia* (Bridson) Razafim., Lantz & B. Bremer, *B. mombazensis* (Baill.) Razafim., Lantz & B. Bremer, *B. pseudosetiflora* (Bridson) Razafim., Lantz & B. Bremer, and *B. setiflora* (Hiern) Razafim., Lantz & B. Bremer. Furthermore, the results seem to point to a single origin of functional dioecy followed by subsequent reversals back to the hermaphroditic conditions at least within the *Cyclophyllum*–*Canthium confertum* clade and *Pyrostria* s.l. The Malagasy *Bullockia* species seem to have an African ancestor, whereas the Comorean *Peponidium* and the African *Pyrostria* appear to have originated from Malagasy progenitors.

Key words: Biogeography, *Bullockia*, *Canthium*, *Cyclophyllum*, ETS, functional dioecy, ITS, *Peponidium*, *Pyrostria*, Rubiaceae, Vanguerieae.

The tribe Vanguerieae comprises between 600 and 700 species of trees, shrubs, geofrutices, and climbers, which are classified in 17 (Lantz & Bremer, 2004, 2005), 27 (Robbrecht, 1988), or 37 (Bridson,

unpublished talk) genera depending on the generic limits used. Vanguerieae belongs to the subfamily Ixoroideae s.l. (Bremer et al., 1999) of the coffee family (Rubiaceae) and is a monophyletic group,

¹ We thank Aaron Davis (Royal Botanic Gardens, Kew, England), Thierry Pailler (Université de la Réunion, France), and Sylvie Andriambololona (Missouri Botanical Garden Program, Madagascar) for kindly providing DNA material for this study; Ministère des Eaux et Forêts (MEF) and Association Nationale pour la Gestion des Aires Protégées (ANGAP) for issuing collecting permits for SGR; Missouri Botanical Garden Program, Madagascar (especially Lalao Andriamahefarivo) for arranging collecting permits for SGR; Désiré Ravelonarivo for being an excellent field assistant in Marojejy National Park; the following herbaria for providing loans and access to collections: BR, GB, Herbarium Universitaire de la Réunion, K, MO, P, S, TAN, TEF, and UPS; and Simon Owens (curator of K) for kindly sending us scanned images of the type specimens of five species of *Canthium* subgen. *Bullockia*. This study was funded by the Bergius Foundation, the Swedish Research Council, and the Knut and Alice Wallenberg Foundation to BB.

² Bergius Foundation, Royal Swedish Academy of Sciences, and Department of Botany, Stockholm University, SE-10691, Stockholm, Sweden. sylvain.razafimandimbison@bergianska.se; arnaud@bergianska.se; birgitta.bremer@bergianska.se.

³ Systematic Botany Department, Evolutionary Biology Centre, Uppsala University, SE-75236, Uppsala, Sweden. henrik.lantz@ebc.uu.se.

doi: 10.3417/2006191

which can be recognized by a combination of the following eight characters: absence of raphides, axillary inflorescences, valvate corolla-lobe aestivation, a unique type of pollen presenter, uniovulate locules, pendulous ovules attached toward the top of septa, drupaceous fruits, and large embryos with superior radicles (Bridson, 1987, 1992, 1998; Lantz et al., 2002). There is a considerable variation in both flower and fruit sizes and shapes, which attract various pollinators and a range of animal dispersers, respectively. The members of the tribe inhabit various habitats, ranging from evergreen rainforests to dry deciduous forests to xerophyllous thickets. They occupy a wide geographic range extending from tropical Africa and Asia, throughout the Indian Ocean islands, to the Pacific region and northern Australia. The African mainland is the center of diversity with ca. 350 species, and Southeast Asia and Madagascar have ca. 150 and 120 species, respectively. In Madagascar, at least 20 new species of *Peponidium* (Baill.) Arènes (Arènes, 1960) and *Pyrostria* Comm. ex Juss. (Jussieu, 1789) are yet to be described (Razafimandimbison et al., unpublished data).

While a member of Vanguerieae is relatively easy to recognize, the generic limits within the tribe have always been considered to be extremely problematic (e.g., Verdcourt, 1958; Bridson, 1987, 1992; Schatz, 2001). A series of recent phylogenetic studies based on both molecular and morphological data conducted by two of the authors (Lantz et al., 2002; Lantz & Bremer, 2004, 2005) led to the establishment of largely new generic circumscriptions of Vanguerieae. Both *Canthium* Lam. sensu Verdcourt and Bridson (1991) and Bridson (1992) and *Pyrostria* (Bridson, 1987) were among the genera shown to be highly polyphyletic. *Canthium* subgen. *Afrocanthium* Bridson was resolved as monophyletic and was more closely related to *Keetia* E. Phillips than it was to the other three subgenera of *Canthium* described by Bridson (1987, 1992): *Canthium* subgen. *Bullockia* Bridson, *Canthium* subgen. *Canthium*, and *Canthium* subgen. *Lycioserissa* (Roem. & Schultes) Bridson. As a result, Lantz and Bremer (2004) raised *Canthium* subgen. *Afrocanthium* to the generic level and restricted *Canthium* to include only species with paired supra-axillary spines. In addition, Lantz and Bremer's (2004) study identified for the first time a strongly supported and mostly dioecious clade (hereafter the dioecious group), which contained all sequenced species of *Canthium* subgen. *Bullockia*, *Dinocanthium* Bremek. (Bremekamp, 1933), *Leroya* Cavaco (Cavaco, 1970), *Neoleroya* Cavaco (Cavaco, 1971a), *Peponidium*, *Pseudopeponidium* Homolles ex Arènes (Arènes, 1960), *Pyrostria*, and *Scyphochlamys* Balf. f. (Balfour, 1877; Verdcourt, 1983). The genus *Cyclo-*

phyllum Hook. f. (Hooker, 1873) was, however, erroneously included as part of the dioecious group in Lantz and Bremer's (2004) figures 1 and 5. In total, the dioecious group sensu Lantz and Bremer (2004) comprises at least 22% (ca. 140 species) of the total species of Vanguerieae and has its center of species diversity in Madagascar with ca. 71% (at least 100 species [Govaerts et al., 2006; Davis et al., 2007; Lantz et al., 2007; Razafimandimbison et al., 2007]). Mainland Africa has ca. 14% (ca. 19 species [Bridson, 1987]), and the Comoro, Mascarene, and Seychelles islands together have ca. 9% (ca. 13 species [Verdcourt, 1983; Friedmann, 1994; Mouly, 2007]). The number of the species of the Southeast Asian *Pyrostria* group B (sensu Bridson, 1987) is currently unknown. The generic limits within the dioecious group were not addressed in Lantz and Bremer (2004) mainly due to lack of internal phylogenetic support and limited sampling of *Pyrostria* and its allied genera. The establishment of the new narrowly circumscribed *Canthium* by Lantz and Bremer (2004) has left *Canthium* subgen. *Bullockia* and the two groups of *Canthium* species (one consisting of the Indian Ocean and Comorean *Canthium* species corresponding to the two-locular species of group V [sensu Bridson, 1987] and the other consisting of the Southeast Asian *C. confertum* Korth. group or group IV [sensu Bridson, 1987]) unplaced within Vanguerieae.

The circumscriptions of *Pyrostria* have always been controversial and unsettled (see Table 1), and there are at least two reasons for this situation. First, the circumscriptions of some of the closely related genera (e.g., *Dinocanthium* [Bremekamp, 1933]; *Pseudopeponidium* [Arènes, 1960]; Table 2) largely overlapped with the early narrow circumscriptions of *Pyrostria* (Jussieu, 1789; Cavaco, 1967) based on the combination of three characters, i.e., presence or absence of persistent, basally fused, and long acuminate paired bracts completely enclosing the young inflorescence, type of sexual systems, and number of locules per ovary (see Table 1). Second, previous authors proposed conflicting morphological concepts of *Pyrostria* as a result of the application of different weightings to the above characters (Tables 1, 2) used in combination (Jussieu, 1789; Cavaco, 1967) or as "cardinals" (Capuron, 1969; Bridson, 1987). The monophyly of these competing circumscriptions of *Pyrostria* has never been tested before using molecular phylogenies. In addition, Capuron (1969) even questioned the identity of *Pyrostria* and viewed the Malagasy *Canthium*, almost all erroneously described as hermaphrodite by Cavaco (1972), as dioecious. He intended to group all other dioecious Malagasy Vanguerieae genera (*Peponidium*, *Pseudopeponidium*,

Table 1. Previous and new circumscriptions of *Pyrostria*.

Authors	Characters used for circumscribing <i>Pyrostria</i>	Variable characters	Genera included in <i>Pyrostria</i>	Genera not included in <i>Pyrostria</i>
Jussieu (1789)	plurilocular ovary, paired bracts, dioecy	—	—	—
Cavaco (1967) ¹	two-locular ovary, paired bracts, dioecy	—	—	<i>Peponidium</i> and <i>Pseudopeponidium</i>
Capuron (1969) ¹	functional dioecy	two to plurilocular ovary, with or without paired bracts	<i>Peponidium</i> and <i>Pseudopeponidium</i>	—
Cavaco (1972) ¹	functional dioecy	two to plurilocular ovary, with or without paired bracts	<i>Peponidium</i> and <i>Pseudopeponidium</i>	<i>Leroya</i> and <i>Neoleroya</i>
Bridson (1987)	presence of persistent and basally connate paired bracts	two to plurilocular ovary, sexual systems (functionally dioecious or hermaphrodite)	<i>Dinocanthium</i> , <i>Leroya</i> , <i>Neoleroya</i> , and <i>Pseudopeponidium</i>	<i>Cyclophyllum</i> , <i>Peponidium</i> , and <i>Scyphochlamys</i>
Schatz (2001) ¹	functional dioecy	two to plurilocular ovary, with or without paired bracts	<i>Leroya</i> , <i>Neoleroya</i> , <i>Peponidium</i> , and <i>Pseudopeponidium</i>	—
Razafimandimbison et al. (this study)	presence of persistent and basally connate paired bracts	two to plurilocular ovary breeding systems (functionally dioecious or hermaphrodite)	<i>Dinocanthium</i> , <i>Leroya</i> , <i>Neoleroya</i> , <i>Pseudopeponidium</i> , and <i>Scyphochlamys</i>	<i>Cyclophyllum</i> and <i>Peponidium</i>

¹ Taxa from Madagascar and the Comoro Islands are considered herein.

and *Pyrostria*) under *Canthium* based on accumbent (as “accompants” [Capuron, 1969]) cotyledons (cotyledons lying against the radicle along one edge [Harris & Harris, 1994]). Leroy (1972: 1683), seemingly influenced by Capuron (1969), used the term “*Canthium–Pyrostria sensu lato*” for the Malagasy

species (including both *Leroya* and *Neoleroya*) with the typical paired bracts of *Pyrostria*. Schatz (2001: 339) also recognized the Malagasy *Canthium* as dioecious but treated them as *Canthium* and maintained the generic status of *Pyrostria* (including *Leroya*, *Neoleroya*, *Peponidium*, and *Pseudopeponi-*

Table 2. Comparison between all described genera of the dioecious group sensu Lantz and Bremer (2004), *Cyclophyllum*, the Comorean and Indian Ocean *Canthium*, and the Southeast Asian *Canthium confertum* group.

Taxa	No. of locules per ovary ¹	Type of inflorescence bracts ¹	Type of sexual systems ¹
<i>Canthium</i> (Comoro Islands and Indian Ocean)	2	cupular bracts	functional dioecy
<i>Canthium confertum</i> group	2 to 6	without bracts	hermaphroditism
<i>Canthium</i> subgen. <i>Bullockia</i>	2	without bracts	functional dioecy
<i>Cyclophyllum</i>	2	variable	hermaphroditism and functional dioecy
<i>Dinocanthium</i> ²	4 to 6	paired bracts	functional dioecy
<i>Leroya</i> ^{2,3}	4 to 6	paired bracts	functional dioecy
<i>Neoleroya</i> ^{2,3}	2	paired bracts	functional dioecy
<i>Peponidium</i> ^{3,4}	2 to 10	cupular bracts	functional dioecy
<i>Pseudopeponidium</i> ^{2,3,4}	2 to 10	paired bracts	functional dioecy
<i>Pyrostria sensu Cavaco</i> (1967) ⁴	2	paired bracts	functional dioecy
<i>Pyrostria sensu Jussieu</i> (1789) ⁴	8	paired bracts	functional dioecy
<i>Scyphochlamys</i>	4 to 6	spathe-like bracts	functional dioecy

¹ Characters traditionally and currently used in combination or as cardinals for delimiting *Pyrostria*.

² Genera merged by Bridson (1987) with *Pyrostria*.

³ Genera merged by Schatz (2001) with *Pyrostria*.

⁴ Genera considered by Capuron (1969) as merged with *Canthium* based on the presence of accumbent cotyledons.

Table 3. List of the known dioecious Rubiaceae.

Subfamilies (sensu Bremer et al., 1999)	Tribes	Taxa	References	
Cinchonoideae	Guettardeae	<i>Antirhea borbonica</i> J. F. Gmel. ^{1,2}	Litrico et al. (2005)	
		<i>Bobeia</i> Gaudich.	Achille et al. (2006)	
		<i>Guettarda</i> L. ²	Achille et al. (2006)	
Ixoroideae s.l.	Bertiareae	<i>Tinadendron</i> Achille	Achille (2006)	
		<i>Bertiera borbonica</i> A. Rich. ^{1,2}	Pailler et al. (1998)	
	Coffeeae	<i>Tricalysia</i> A. Rich. ²	Robbrecht (1979)	
		Condamineae	<i>Dioicodendron</i> Steyerm.	Delprete (1999)
	<i>Dolicholobium</i> A. Gray ²		Skottsberg (1944)	
	Gardenieae	<i>Agouticarpa</i> C. H. Perss.	Persson (2003)	
		<i>Alibertia</i> A. Rich. group	Persson (2000)	
		<i>Atractocarpus</i> Schltr. & K. Krause ²	Puttock (1999)	
		<i>Casasia</i> A. Rich.	Robbrecht (1988)	
		<i>Gardenia actinocarpa</i> Puttock ²	Osunkoya (2003)	
		<i>Melanopsidium</i> Colla	Delprete (2000)	
		<i>Randia</i> L.	Gustafsson & Persson (2002)	
		<i>Trukia</i> Kanehira	Smith & Darwin (1988)	
		Ixoreae	<i>Doricera</i> Verdc.	Verdcourt (1983)
			<i>Ixora pudica</i> Baker ^{1,2}	Friedmann (1994)
	Mussaendeae	<i>Mussaenda parviflora</i> Miq. ^{1,2}	Burck (1883); Baker (1958); Naiki & Kato (1999)	
	Octotropideae	<i>Kraussia</i> Harv.	Skottsberg (1944)	
	Vanguerieae	<i>Bullockia</i> (Bridson) Razafim., Lantz & B. Bremer ¹ (this study)	Bridson (1987); this study	
		<i>Canthium laeve</i> Teijsm. & Binn. ^{1,2}	Burck (1884)	
<i>Cyclophyllum</i> Hook. f. ^{1,2}		Mouly et al. (2007)		
<i>Peponidium</i> (Baill.) Arènes s.l. ¹ (this study)		Arènes (1960); Bridson (1987); this study		
<i>Pyrostria</i> Comm. ex Juss. s.l. ¹ (this study)		Bridson (1987); Verdcourt (1983)		
<i>Pyrostria</i> Comm. ex Juss. s.l. ¹ (this study)		Bridson (1987); Verdcourt (1983)		
Rubioideae	Anthospermeae	<i>Coprosma billardieri</i> Hook. f. ²	Skottsberg (1922)	
		<i>Normandia</i> Hook. f.	Guillaumin (1930)	
	Coussareae	<i>Coussarea latifolia</i> Standl. ²	Burger & Taylor (1993)	
		<i>Coussarea talamancana</i> Standl. ²	Beach & Bawa (1980)	
	Gaertnereae	<i>Gaertnera</i> Lam. ²	van Beusekom (1967)	
	Morindeae s. str.	<i>Morinda</i> L. ²	Burck (1883); Wong (1984)	
		Psychotrieae	<i>Chassalia corallioides</i> (Cordem.) Verdc. ^{1,2}	Pailler et al. (1995)
	<i>Psychotria officinalis</i> (Aubl.) Raeusch. ex Sandwith ²		Hamilton (1990)	
	<i>Gouldia</i> A. Gray ²		Burck (1884)	
	Spermacoaceae	<i>Hedyotis</i> L. ²	Baker & Cox (1984)	
		<i>Kadua</i> Cham. & Schltdl. ²	Wagner & Lorence (1998)	
		<i>Nesohedyotis arborea</i> (Roxb.) Bremek.	Percy & Cronk (1997)	

¹ Taxa reported to be functionally dioecious.² Genera known to have some or many hermaphroditic species.

dium) (see Table 1). No species of the Indian Ocean or Comorean *Canthium* were included in Lantz and Bremer (2004, 2005).

Breeding systems have been shown to have evolved independently numerous times throughout angiosperms (e.g., Renner & Ricklefs, 1995; Sakai et al., 1995; Weiblen et al., 2000). As in most flowering plant families, hermaphroditism is the most common

breeding system in Rubiaceae. Monoecy, separate male and female flowers on each plant (Heilbut, 2000), has been recorded at least in the monogeneric tribe Theligoneae (Robbrecht, 1988), presently classified in Rubioideae (Bremer & Manen, 2000). Dioecy, male or female flowers on separate individuals of the same species, has been reported in many genera in all three subfamilies (sensu Bremer et al.,

1999) of Rubiaceae (see Table 3). In the functionally dioecious Vanguerieae species, unisexual flowers are morphologically hermaphrodite but functionally dioecious; the functionally female flowers produce functional ovaries and stigmatic lobes but sterile anthers, whereas the functionally male flowers bear reduced or nonfunctional ovaries and stigmatic lobes but fertile anthers. The two forms are usually easy to distinguish because the functionally female plants have flowers with well-developed ovaries and one- to few-flowered inflorescences, rather than small ovaries and many-flowered inflorescences in the functional male plants (Bridson, 1987). In Vanguerieae, functional dioecy (also known as cryptic dioecy [Mayer & Charlesworth, 1991]) is commonly found in *Pyrostria* and its allied genera (Bridson, 1987) and was once reported from the Asian *Canthium laeve* Teijsm. & Binn. (Burck, 1884). The phylogenetic placement of *C. laeve* is currently unknown, and therefore we do not know whether the species represents a separate origin of functional dioecy in the tribe or belongs to the dioecious group. Two African and one Afro-Comorean-Indian Ocean *Pyrostria* species have been reported to be hermaphroditic (Bridson, 1987). In addition, gynodioecy, a regular coexistence of hermaphrodite and female flowers on the same individual (Mayer & Charlesworth, 1991), was reported from *Psydrax odorata* (G. Forst.) A. C. Sm. & S. P. Darwin (as *Canthium odoratum* (G. Forst.) Seem. [Skottsberg, 1945]) and from *Afrocanthium gilfillanii* (N. E. Br.) Lantz (Bridson, 1998: 324) and *A. mundianum* (Cham. & Schltdl.) Lantz (Balkwill et al., 1996).

The ITS of the nuclear ribosomal DNA (nrDNA) have been shown to be useful for assessing phylogenetic relationships at the generic level in some rubiaceous groups (e.g., Gardenieae [Persson, 2000]; Naucleaeae s.l. [Razafimandimbison & Bremer, 2001, 2002]; Vanguerieae [Lantz et al., 2002]; Mussaendeae [Alejandro et al., 2005]). The ETS of the nrDNA, in combination with ITS data, have also recently been used in Rubiaceae for assessing phylogenetic relationships of young lineages (e.g., Nepokroeff et al., 2003; Razafimandimbison et al., 2005). The main objective of this study is to reconstruct a robust phylogeny of the dioecious group using sequencing data from two nuclear markers, ETS and ITS regions. The resulting phylogeny will then be used to: (1) pinpoint the phylogenetic positions of the Comorean and Indian Ocean *Canthium* and the Southeast Asian *C. confertum* group in Vanguerieae; (2) evaluate the phylogenetic utility of three taxonomic characters (bract type, locule number, and fruit shape) previously and currently used for delimiting genera in the dioecious group (Table 1); and (3) assess the evolution of functional dioecy in Vanguerieae.

MATERIAL AND METHODS

TAXON SAMPLING

We tried to sequence as many representatives as possible of all formally described genera in the dioecious group (see Appendix 1) and the Comorean and Malagasy *Canthium*. We were unable to obtain any sequenceable material of *Pyrostria* group B (Bridson, 1987). As there are currently no available identification keys for the Malagasy *Canthium* and *Pyrostria*, all determinations of the studied collections were made by comparisons to the type specimens received on loan. In total, we sequenced 79 taxa of Vanguerieae, of which 67 taxa were from the dioecious group. Twenty-three of the 67 taxa were new undescribed species of the Malagasy *Canthium*, *Leroya*, *Peponidium*, and *Pyrostria* (see Appendix 1). All formally published generic names in the dioecious group are used in the trees (Figs. 1–3), although we are aware that no single author accepts all of them.

DNA EXTRACTION, AMPLIFICATION, AND SEQUENCING

The total DNA, extracted from leaves dried in silica gel (Chase & Hills, 1991) and/or herbarium material, was isolated following the mini-prep procedure of Saghai-Marooft et al. (1984), as modified by Doyle and Doyle (1987). We amplified and sequenced parts of the ETS region of all investigated taxa with two primers, 18S-E (5'-GCAGGATCAACCAGGTGAA-3'), designed by Baldwin and Markos (1998) and situated at the 5' border of 18S and ETS, and ETS-HL (5'-GATCACAGCCTGAGC GGTG-3'), designed by H. Lantz and located at the 3' border of ETS, following the protocols described in Razafimandimbison et al. (2005). The entire ITS region (including the 5.8S gene) of all newly studied taxa was amplified and sequenced using the protocols outlined in Razafimandimbison et al. (2004). In addition, we amplified the ETS and ITS regions of the DNA templates of both *Peponidium* sp. indet. 6 and *Pseudopeponidium oleifolium* Arènes using the 97°C/ribosomal RNA primers described in Razafimandimbison et al. (2004). Direct sequencing of their purified PCR products consistently produced multiple sequence signals for both markers, indicating the presence of intraindividual polymorphism. As a result, the PCR products of both taxa were cloned according to the TOPO TA cloning kit (Invitrogen, Paisley, Scotland) (see Razafimandimbison et al., 2004). Four white colonies from both the ETS and ITS cloning reactions were screened and amplified with two universal primers, T7 (5'-AAT ACG CTC ACT ATA G-3') and M13R (5'-CAG GAA ACA GCT ATG AC-3'), which were included in the TOPO TA cloning kit. Their

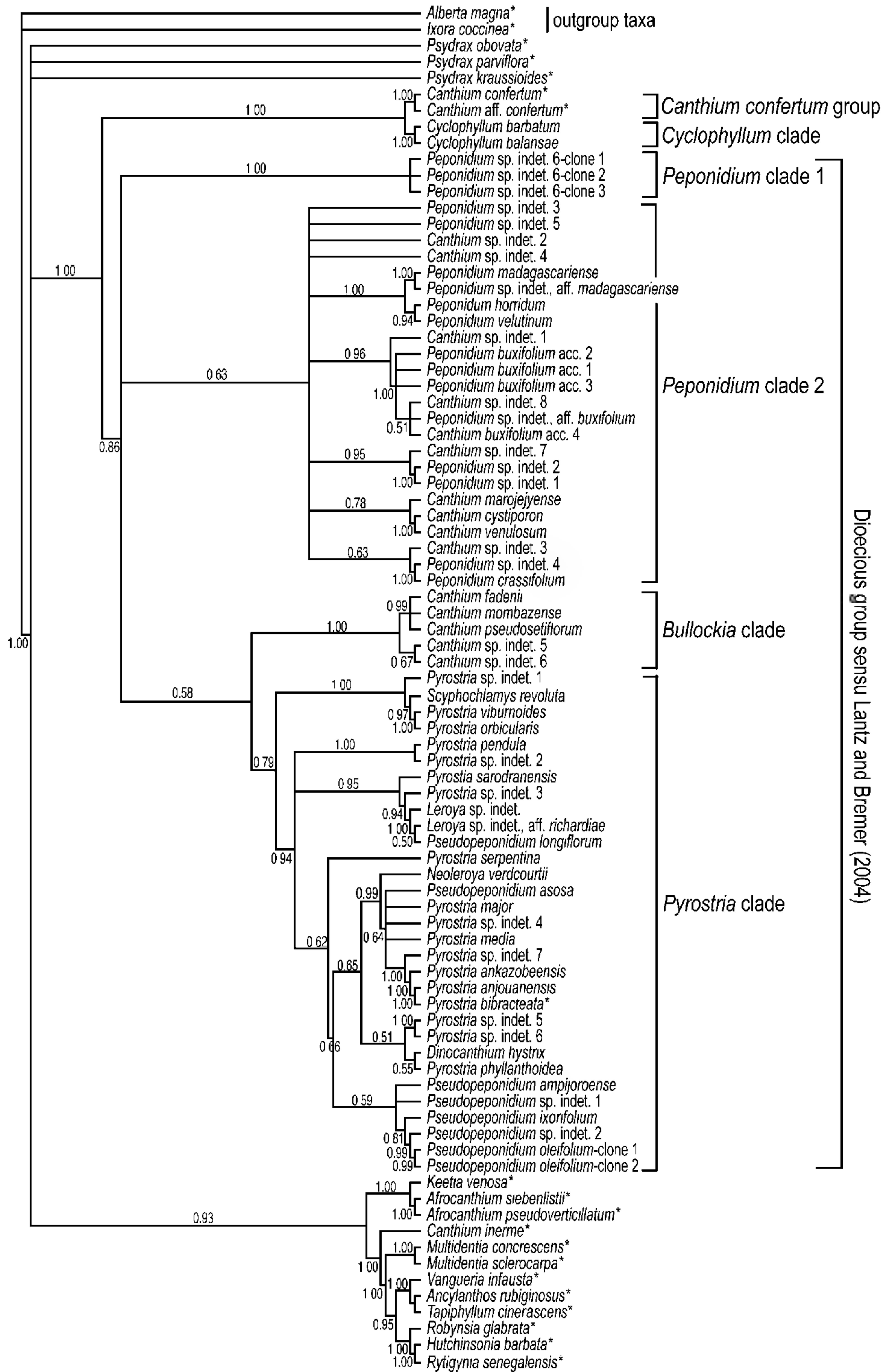

Figure 1. Fifty percent Bayesian majority rule consensus ITS tree under the GTR + I + G model of substitution from a 2-million MCMC generation analysis, showing mean branch lengths. Numbers on internodes indicate PPs. A vertical bar delimits outgroup taxa. Brackets correspond to the major clades and the dioecious group. *Denotes hermaphroditic taxa.

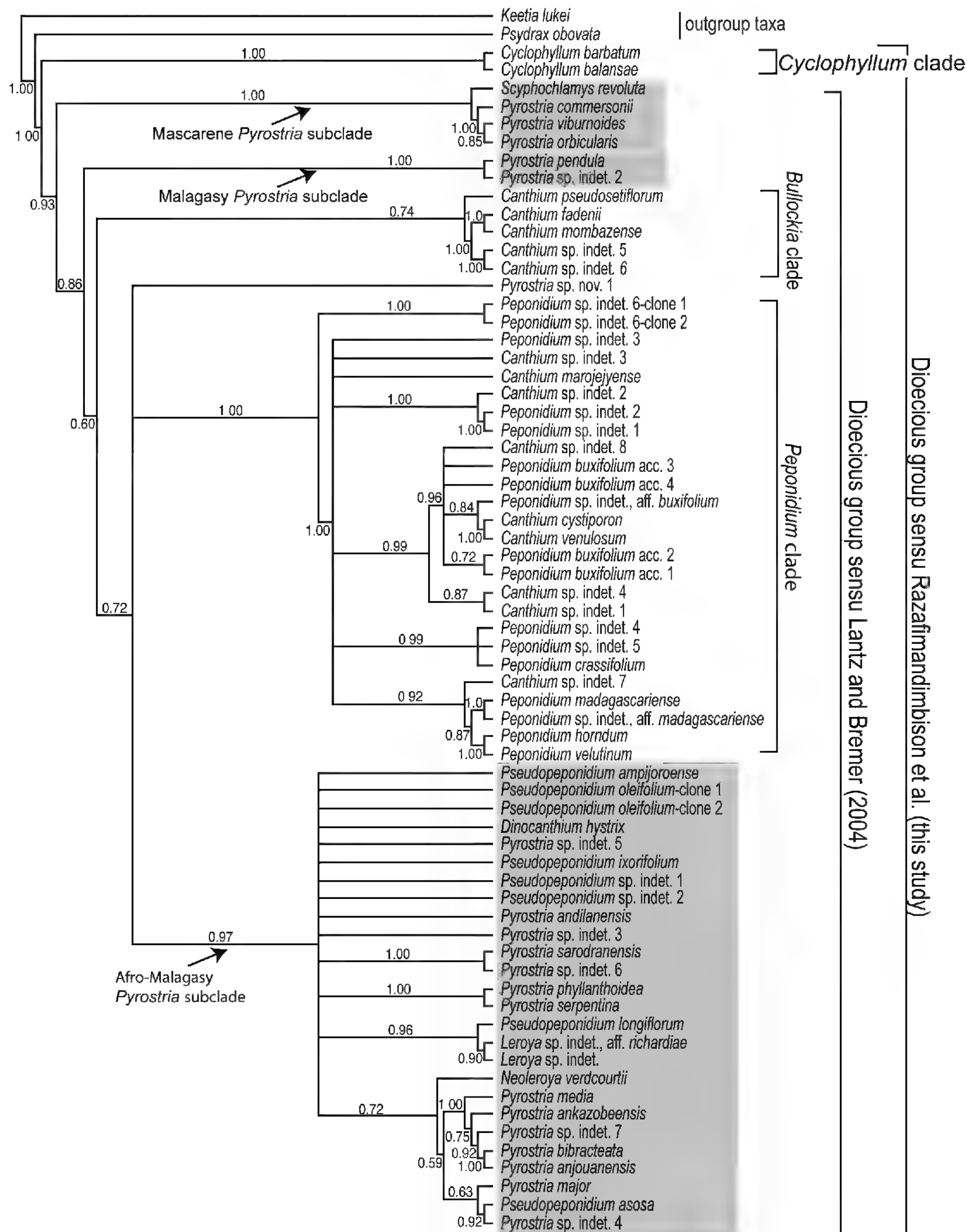

Figure 2. Fifty percent Bayesian majority rule consensus ETS tree under the GTR + G model of substitution from a 2-million MCMC generation analysis, showing mean branch lengths. Numbers on internodes indicate PPs. Taxa highlighted in shaded boxes are subclades belonging to the *Pyrostria* group. The vertical bar delimits outgroup taxa. Brackets correspond to the major clades.

respective purified PCR products were sequenced with the 18S-E/ETS-HL and P17/26.82R (Popp & Oxelman, 2001). In all PCRs, one reaction was run with water instead of DNA as a negative control to check for

contamination. All sequencing reactions were performed using the Big Dye Terminator v3.1 Cycle Sequencing kit and Big Dye Terminator v1.1 Cycle Sequencing kit (Applied Biosystems, Stockholm,

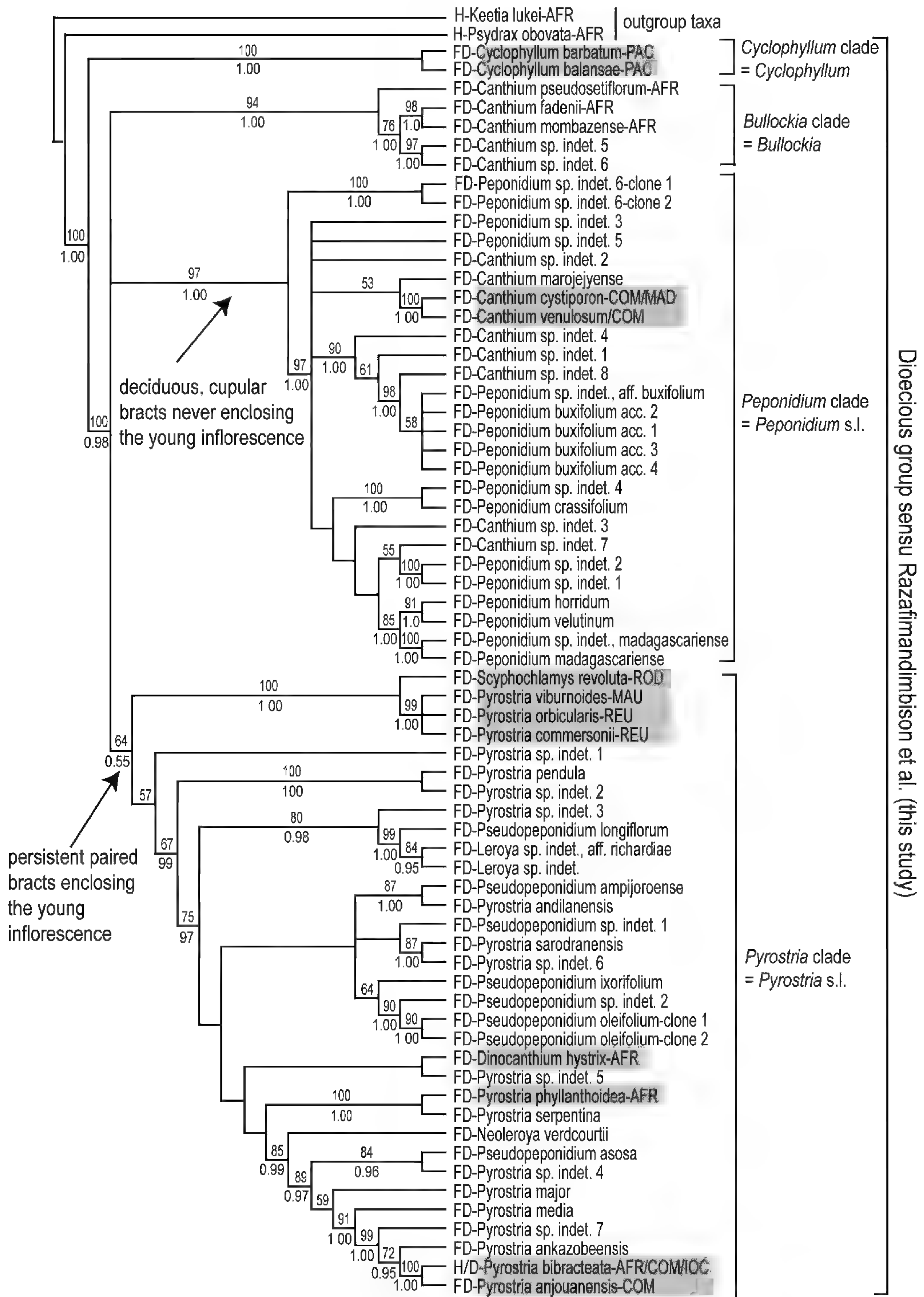

Figure 3. Parsimony strict consensus tree of 1555 MPTs of the combined ITS/ETS data (L = 822; CI = 0.421; RI = 0.735) with the new classification of the dioecious group implemented. Numbers above internodes are JK support (> 50%), and those below internodes correspond to PP values from a Bayesian analysis of the same data sets. The vertical bar delimits outgroup taxa, and brackets denote the major clades. Abbreviations preceding plant names indicate functionally dioecious (FD) taxa and hermaphroditic (H) taxa. Abbreviations after taxa names indicate taxa distribution: AFR – African mainland; COM – Comoro Islands; IOC – Indian Ocean; MAD – Madagascar; MAU – Mauritius; REU – Réunion Island; and ROD – Rodrigues Island; the remaining ingroup taxa are endemic to Madagascar.

Sweden) and subsequently analyzed with the 3100 Genetic Analyzer (Applied Biosystems).

DATA ANALYSES

The ETS and ITS sequences were assembled using the Staden Package version 1.6.0 beta-test (Staden, 1996) and aligned using ClustalX (Thompson et al., 1997) to produce an initial alignment and manually aligned using Se-Al (Rambaut, 1996). All newly published sequences have been submitted to the European Molecular Biology Laboratory (EMBL). We initially performed a Bayesian analysis of the ITS data with the computer program MrBayes 3.0b (Huelsenbeck & Ronquist, 2001). The best-fit model of nucleotide substitution (GTR + I + G [Yang, 1994]) was selected using the computer program MrModeltest 2.0 (Nylander, 2004) and Akaike's information criterion (Akaike, 1974). The Bayesian ITS analysis (excluding indels) was conducted with four independent Markov chains run for 2×10^6 Metropolis-coupled Markov chain Monte Carlo (MCMC) generations, with tree sampling every 1×10^3 generations and burn-in after 1×10^3 trees (as detected by plotting the log likelihood scores against generation number). The analyses were repeated four times using different random starting trees to evaluate the convergence of the likelihood values and posterior probabilities (PPs). All saved trees from the four independent runs were pooled for a consensus tree. Groups characterized by PPs more than 95% were regarded as strongly supported.

Based on the results of the Bayesian ITS analysis, we selected two closer outgroup taxa (*Psydrax obovata* (Klotzsch ex Eckl. & Zeyh.) Bridson and *Keetia lukei* Bridson) from within Vanguerieae to root the analyses of the ETS and combined ETS/ITS data from all targeted taxa of the dioecious group and both the Comorean and Malagasy *Canthium*. We subsequently carried out Bayesian analyses of the ETS and the combined ETS/ITS data sets using the same settings as above but with the GTR + G model of nucleotide substitution, selected as the best-fit model for the two ETS and ITS data sets. We performed parsimony analyses of the four data sets (excluding uninformative characters) with PAUP* version 4.0b (Swofford, 2000), using heuristic searches, with the MULTREES option on, tree bisection-reconnection (TBR) branch swapping, swap on best tree only in effect, and 5000 random addition sequences. In all analyses, characters were given equal weight, gaps were treated as missing data, and phylogenetically informative indels were coded following the simple gap coding method of Simmons and Ochoterena (2000). The consistency index (CI; Kluge & Farris, 1969) and retention index

(RI; Farris, 1989) were calculated to estimate homoplasy. Jackknife (JK; Farris et al., 1995) values were computed using heuristic searches, with MULTREES on, TBR branch swapping, five random additions, and 5000 replicates to assess relative support of the retained clades.

We statistically evaluated the congruence of the ETS and ITS data sets using the incongruence length difference test (ILD test; Farris et al., 1995), as implemented in PAUP* (Swofford, 2000). The heuristic search was set to 500 replicates with 10 random addition sequence and nearest-neighbor interchange (NNI) branch swapping. If the probability of obtaining a smaller sum of tree lengths from the randomly generated data sets is lower ($P < 0.05$) than that of the original data sets, the null hypothesis that the two data sets are homogenous is rejected and they are interpreted as incongruent (Farris et al., 1995).

RESULTS

ITS ANALYSES

A total of 84 ITS sequences were analyzed and 58 (ca. 69%) are newly published here. The ITS matrix contained 776 positions and 189 (24.35%) were parsimony informative. Both the parsimony strict consensus (length [L] = 790, CI = 0.439, RI = 0.727; result not shown) and Bayesian ITS trees had similar overall tree topologies, which were not in conflict with those of Lantz and Bremer (2004). In the Bayesian majority rule consensus tree pooled from the Bayesian trees (burn-ins excluded) from the four independent runs shown in Figure 1, all sequenced taxa of the dioecious group sensu Lantz and Bremer (2004) formed a moderately supported monophyletic group (PP = 0.86), which was resolved as sister (PP = 1.00) to a clade containing the two studied species of *Cyclophyllum* and two accessions of *Canthium confertum* (PP = 1.00). The three hermaphroditic *Psydrax* species were unresolved, and the hermaphroditic 12 remaining Vanguerieae taxa formed a moderately supported clade (PP = 0.93). The members of the dioecious group sensu Lantz and Bremer (2004) were resolved in four clades: the *Peponidium* clade 1 (consisting of the three clonal accessions of *Peponidium* sp. indet. 6; PP = 1.00); the *Peponidium* clade 2 (including the remaining sampled *Peponidium* species and all sequenced Comorean and Malagasy *Canthium* species; PP = 0.63); the *Bullockia* clade (including three species of *Canthium* subgen. *Bullockia* and two undescribed new Malagasy species; PP = 1.00); and the *Pyrostria* clade (including all *Pyrostria*, *Scyphochlamys*, *Leroya*, *Neoleroya*, *Dinocanthium*, and *Pseudopeponidium* species; PP =

0.79). The relationships between the four dioecious clades were largely unresolved.

ETS ANALYSES

A total of 68 ETS sequences were analyzed together and all are newly published here. The aligned ETS matrix contained 421 positions, and 130 (30.8%), including coded indels, were phylogenetically informative. In the Bayesian ETS tree shown in Figure 2, the *Cyclophyllum* clade was resolved with high support (PP = 1.00) as sister to the moderately supported (PP = 0.93) dioecious group sensu Lantz and Bremer (2004). Within the dioecious group, all deep nodes received only poor (PP = 0.60) to moderate (PP = 0.86) support (Fig. 2). The *Pyrostria* clade, weakly supported in the ITS tree (Fig. 1), collapsed in three highly supported subclades (PP = 0.97–1.00): a Mascarene *Pyrostria* subclade; a subclade containing two Malagasy *Pyrostria* species, *P. pendula* Lantz, Klack. & Razafim. and *Pyrostria* sp. indet. 2; and an Afro-Malagasy *Pyrostria* subclade (including all studied species of *Dinocanthium*, *Leroya*, *Neoleroya*, and *Pseudopeponidium*). The *Peponidium* clades 1 and 2 in the ITS tree (Fig. 1) formed a well-supported monophyletic group (hereafter called the *Peponidium* clade; PP = 1.00). *Pyrostria* sp. indet. 1, the *Peponidium* clade, and the Afro-Malagasy *Pyrostria* subclade were unresolved in a weakly supported clade (PP = 0.72). Two ETS clonal sequences of *Peponidium* sp. indet. 6 formed a highly supported clade (PP = 1.00), which in turn was sister to a well-supported clade corresponding to the *Peponidium* clade in Figure 1. The *Cyclophyllum* clade received high support (PP = 1.00), while the *Bullockia* clade had only weak support (PP = 0.74).

A parsimony analysis of the ETS matrix resulted in 52 equally most parsimonious trees (MPTs; L = 409, CI = 0.430, RI = 0.762). In the strict consensus ETS tree generated from the 52 MPTs (result not shown), the *Pyrostria* clade was resolved in two separate clades: the strongly supported (PP = 1.00) *Mascarene-Pyrostria* clade and the poorly supported (PP < 0.50) Afro-Malagasy *Pyrostria* clade (including *Dinocanthium*, *Leroya*, *Neoleroya*, *Pseudopeponidium*, *Pyrostria* sp. indet. 1, *Pyrostria* sp. indet. 2, and *Pyrostria pendula*). The *Bullockia*, *Cyclophyllum*, and *Peponidium* clades all received the same levels of support as in the Bayesian ETS tree (Fig. 2).

COMBINED ANALYSES

The results of the ILD test indicated that the two data sets were not significantly incongruent and therefore

could be combined. Fusion of the ETS and ITS data sets of 68 taxa in one matrix yielded 1122 positions and 238 parsimony-informative characters (including coded indels). Both Bayesian and parsimony analyses of the combined ETS/ITS data produced identical tree topologies. A parsimony analysis of the combined ETS/ITS data resulted in 1555 equally MPTs (L = 822, CI = 0.421, RI = 0.735). In the strict consensus tree shown in Figure 3, the ingroup taxa were resolved in four major clades (Fig. 3): the *Cyclophyllum* clade (= *Cyclophyllum*), the *Bullockia* clade (= *Bullockia* (Bridson) Razafim., Lantz & B. Bremer), and the *Peponidium* clade (= *Peponidium* s.l.), all with high support (JK = 94–100, PP = 1.00), and the *Pyrostria* clade (= *Pyrostria* s.l.; JK = 55, PP = 0.64). The highly supported Mascarene subclade (JK = 100, PP = 1.00) was resolved as sister to the poorly supported (JK = 57) Afro-Malagasy *Pyrostria* subclade. The position of the *Cyclophyllum* clade as sister to the strongly supported (JK = 100, PP = 1.00) dioecious group sensu Lantz and Bremer (2004) was further corroborated. However, the phylogenetic relationships between the *Bullockia*, *Peponidium*, and *Pyrostria* clades remained unresolved. Both *Pseudopeponidium* and *Pyrostria* were shown to be paraphyletic or polyphyletic, while *Leroya*, represented by *Leroya* sp. indet., aff. *richardiae*, and *Leroya* sp. indet., formed a highly monophyletic group. Finally, both *Leroya* and *Neoleroya* were deeply nested within the *Pyrostria* clade.

DISCUSSION

FURTHER DISINTEGRATION OF *CANTHIUM* S.L.

The Bayesian ITS analysis (Fig. 1) reveals a further disintegration of *Canthium* s.l., as the Southeast Asian *C. confertum* (currently placed in group IV sensu Bridson [1987] and represented here by two accessions of *C. confertum*) is for the first time shown to be closely related to *Cyclophyllum*. However, this does not necessarily apply to the whole group IV (sensu Bridson, 1987), as its monophyly has never been tested before. In ETS and combined ETS/ITS trees (Figs. 2, 3), the sequenced Comorean and Indian Ocean *Canthium* species form a highly supported clade with the sampled *Peponidium* (JK = 97, PP = 1.00). In addition, all our analyses (Figs. 1–3) further corroborate the phylogenetic position of *Canthium* subgen. *Bullockia* in the dioecious group previously demonstrated by Lantz and Bremer (2004).

EVOLUTIONARY TRENDS IN THE DIOECIOUS GROUP ACCORDING TO THIS STUDY

Phylogenetic reconstructions can help us understand how morphological variation found within a

monophyletic group has evolved and also highlight synapomorphies for group recognition.

Bract type

The combined ETS/ITS tree (Fig. 3) points to single origins of both the persistent, basally connate paired bracts of the *Pyrostria* clade (consistent with Lantz & Bremer, 2004) and the deciduous, small cupular bracts of the *Peponidium* clade within the dioecious group (see Fig. 3, Table 2). We consider these characters to be the potential morphological synapomorphies for the two clades. In *Pyrostria*, the connate paired bracts completely enclose the young inflorescences and are located either at the base or at the apex of the peduncles. Many New Caledonian species of *Cyclophyllum* are known to have small and connate paired bracts that never enclose the young inflorescence, but the typical bracts of *Pyrostria* are reported from the New Caledonian *C. calyculatum* Guillaumin (Guillaumin, 1930). We suspect that this species belongs to *Pyrostria*. The *Bullockia* clade and *Canthium confertum* group have no bracts.

Locule number

The number of locules per ovary, previously used by Jussieu (1789) and Cavaco (1967), in combination with two other characters (e.g., type of breeding systems) for delimiting *Pyrostria* in a narrow sense, is clearly shown to have evolved independently numerous times (i.e., are homoplasious) within the dioecious group (see also Table 2) and in the other parts of Vanguerieae; this is also congruent with Lantz and Bremer (2004).

Ovary/fruit shape

Leroy (1972: table 1), as well as field observations and herbarium studies conducted by two of the authors (SGR and HL), demonstrate a great and continuous variation of both ovary and fruit shapes and sizes in the *Pyrostria* clade. Cavaco (1970, 1971a) appears to have overlooked or was unaware of the presence of many *Pyrostria* species with intermediate ovary and fruit shapes (Leroy, 1972) between those of *Leroya* and *Neoleroya*. The phylogenetic positions of both *Leroya* and *Neoleroya* deeply nested inside the *Pyrostria* clade are congruent with our field observations and herbarium studies. In addition, the same degree of variation is also found in the *Cyclophyllum* and *Peponidium* clades, further indicating that both fruit shape and size cannot be used alone for recognizing genera in the dioecious

group. The members of the *Bullockia* clade have two-locular and heart-shaped fruits, which are commonly found in the *Peponidium* and *Pyrostria* clades, and many other Vanguerieae genera.

EVOLUTION OF FUNCTIONAL DIOECY IN VANGUERIEAE

The present study supports a single origin of functional dioecy in Vanguerieae (Figs. 1–3). The Asian *Canthium laeve* has also been reported by Burck (1884) to be functionally dioecious. For now, we cannot tell whether functional dioecy had single or multiple origins in the tribe, until the phylogenetic placement of this species within Vanguerieae is known. The Southeast Asian species are, in general, poorly understood, and the breeding systems of most species have yet to be studied. The presence of the nonfunctional sexual organs of the opposite sex on both the functionally male and female flowers indicates that the functional dioecy of Vanguerieae may have originated from hermaphroditism. This may also imply that the functionally dioecious flowers in Vanguerieae are probably in transition to morphologically true dioecious ones (see also Mayer & Charlesworth, 1991). On the other hand, the combined analyses (Fig. 3) indicate that reversals back to the hermaphroditic conditions are also possible, at least within *Pyrostria* s.l. (Fig. 3) and the *Cyclophyllum*–*Canthium confertum* clade, according to Bridson (1987) (see also Table 2). Recent herbarium studies and field observations conducted by A. Mouly reveal that the two sequenced *Cyclophyllum* species and seven other New Caledonian species are actually functionally dioecious (Mouly et al., 2007), inconsistent with Bridson (1987), who considers the genus to be hermaphrodite. Similarly, Friedmann (1994) reported functionally male and female and hermaphroditic flowers from the Afro–Comorean–Indian Ocean *Pyrostria bibracteata* (Baker) Cavaco, which is considered by Bridson to be hermaphroditic. Functionally male and female plants of the same species have also recently been seen by Mouly (2007) on Mayotte Island (France). This further suggests that functional dioecy in Vanguerieae is evolutionarily unstable and, accordingly, should not be used alone for diagnosing any genera within the dioecious group, inconsistent with Capuron (1969), Cavaco (1972), and Schatz (2001) (see Table 1). However, it can still be used for characterizing the genera in the newly circumscribed dioecious group (this study) in combination with other characters.

Finally, all described African, Malagasy, and Mascarene dioecious Vanguerieae species, except the Afro–Comorean–Indian Ocean polygamous *Pyros-*

tria bibracteata and the functionally dioecious Comorean–Malagasy *Canthium cystiporon* Bynum ex Cavaco, are regional endemics (e.g., Bridson, 1987; Cavaco, 1966, 1967, 1968, 1969a, b; Verdcourt, 1983; Schatz, 2001), indicating an autochthonous evolution of functional dioecy in Vanguerieae throughout the geographic ranges of the dioecious group. On the other hand, we cannot yet rule out the origin of the functionally dioecious Mascarene *Pyrostria* species from a functionally dioecious Malagasy or Southeast Asian colonist.

NEW CIRCUMSCRIPTIONS, MAJOR LINEAGES, AND NEW GENERIC LIMITS OF THE DIOECIOUS GROUP

New circumscriptions of the dioecious group

The ITS tree (Fig. 1) resolves the Southeast Asian and hermaphroditic *Canthium confertum* group (sensu Bridson, 1987), represented here by two accessions of *C. confertum*, as sister to the mostly Pacific *Cyclophyllum*. A much larger sampling of *Cyclophyllum* and the *Canthium confertum* group is needed for testing their sister-group relationship. The support for the sister-group relationships between the *Cyclophyllum* clade and the dioecious group sensu Lantz and Bremer (2004) is consistently high in the ETS and combined analyses (Figs. 2, 3) and is also consistent with Mouly et al. (2007). Accordingly, we include *Cyclophyllum* in the dioecious group, which currently contains approximately over 200 species (ca. one third of the total species of Vanguerieae). If the sister-group relationship between *Cyclophyllum* and the *Canthium confertum* group is further confirmed, the *C. confertum* group will have to be considered members of the dioecious group as well. The combined analyses (Fig. 3) indicate that the dioecious group can be subdivided into four morphologically distinct lineages: the *Cyclophyllum* clade, *Bullockia* clade, *Peponidium* clade, and *Pyrostria* clade.

Major lineages of the dioecious group

Cyclophyllum clade. The ETS and combined ETS/ITS analyses (Figs. 2, 3) further corroborate with strong support (JK – 100, PP – 1.00) the sister-group relationships between the *Cyclophyllum* clade and the dioecious group sensu Lantz and Bremer (2004). According to Bridson (1987), *Cyclophyllum* can be characterized by the combination of the following characters: inflorescences without paired bracts; fasciculate inflorescences or occasionally with rudimentary inflorescence branches; large hypocrateriform corollas; hermaphrodite flowers with two-locular ovaries and style widening at apex; and dorsal face of

anthers (except margins) covered with dark connective. However, as we mentioned above, at least nine *Cyclophyllum* species found on New Caledonia are functionally dioecious (Mouly et al., 2007). In addition, at least one New Caledonian species is reported by Guillaumin (1930) to have connate paired bracts that enclose the young inflorescences. This indicates that the monophyly of *Cyclophyllum* as presently delimited needs to be tested. We find no support for Baillon's (1879) suggestion of merging *Cyclophyllum* with *Canthium*, which is presently restricted to the African and Asian spiny species (see Lantz & Bremer, 2004).

Bullockia clade. The *Bullockia* clade, retained in all analyses (Figs. 1–3), comprises three of the six species of *Canthium* subgen. *Bullockia* (Bridson, 1987) and two undescribed new Malagasy species, consistent with Bridson's (1987) prediction. Bridson (1987) used the combination of several characters to distinguish *Canthium* subgen. *Bullockia* from the other subgenera of *Canthium* and *Pyrostria* and its allied genera: persistent leaves; inflorescences unsubtended by the typical *Pyrostria* paired bracts; umbellate or fasciculate inflorescences bearing functionally unisexual flowers; inside of the corolla tube with a well-defined ring of deflected hairs; corollathroat pubescent but not congested with hairs, rarely fleshy corollas; dorsal face of the anthers with only the central area with dark connective or entirely without dark connective; and hollow stigmatic knob (at least near the base) with recessed style. Our close observations of the sequenced Malagasy species, however, show that both of the undescribed new Malagasy species (*Canthium* sp. indet. 5 and 6) have deciduous leaves.

Peponidium clade. In the ETS (Fig. 2) and combined trees (Fig. 3), all sequenced species of *Peponidium* and the Comorean and Malagasy *Canthium* form a strongly supported (JK – 95–97, PP – 1.00) clade. The Comorean *P. comorense* Arènes (Arènes, 1960) and the Seychellean *C. carinatum* (Baker) Summerh. (Friedmann, 1994) have recently been shown to belong to this clade (Avino et al., ETS, ITS, and *trnT-F* unpubl. data). This finding indicates that *Peponidium* sensu Arènes (1960) is not monophyletic, unless the Comorean and Indian Ocean *Canthium* are also included. The *Peponidium* clade (Fig. 3) corresponds to Bridson's (1987) group V, a group she considered to be artificial. In fact, the *Peponidium* clade is supported by at least one potential morphological synapomorphy. The members of the clade can be easily diagnosed by having deciduous, small cupular bracts that are always located at the bases of the inflorescence peduncles

and never enclose the young inflorescences (see also Table 2). Arènes (1960) referred to this type of bract as a false involucre. While the bracts are cup-shaped in most of the species, some species appear to have two to four basally fused and imbricate bracts. This indicates that the cupular bracts in the *Peponidium* clade are most likely to have derived from a complete fusion of more than two bracts. The cupular bracts are conspicuous and often remain intact in species with subsessile and pedunculate inflorescences bearing up to three flowers. In contrast, they are difficult to see and are often crushed in species with sessile inflorescences with four or more flowers, or with both sessile inflorescences and flowers. Finally, neither Lantz and Bremer (2004) nor the present study find support for Capuron's (1969) attempt to merge *Pyrostria* s.l. (including *Peponidium* and *Pseudopeponidium*) in *Canthium* based on accumbent cotyledons.

Pyrostria clade. One of the main goals of the present study is to test the monophyly of the different circumscriptions of *Pyrostria*. The combined analyses (Fig. 3) weakly to moderately support a broad circumscription of *Pyrostria*, which includes all sequenced functionally dioecious species of *Dinocanthium*, *Leroya*, *Neoleroya*, *Pseudopeponidium*, *Pyrostria*, and *Scyphochlamys* and the polygamous *Pyrostria bibracteata*. This broadly circumscribed *Pyrostria* is easy to recognize and distinct from the other genera in the dioecious group (sensu Razafimandimbison et al., this study) and the rest of Vanguerieae in having persistent and basally connate, long acuminate paired bracts (see also Table 2). There is no support for the monophyly of the narrowly delimited *Pyrostria* sensu Jussieu (1789) or Cavaco (1967), as the two-locular or plurilocular species (see Table 2) never form separate clades (Fig. 3). In addition, *Pyrostria* sensu Capuron (1969), sensu Cavaco (1972), and sensu Schatz (2001), all defined by (functional) dioecy (see Table 1), are shown to be paraphyletic because the polygamous *Pyrostria* species (*P. bibracteata*) is deeply nested in the almost functional dioecious *Pyrostria* clade, consistent with Bridson (1987). *Pyrostria* sensu Bridson (1987), diagnosed by the presence of paired bracts, is paraphyletic as it excludes *Scyphochlamys*. No members of the Asian *Pyrostria* group B (Bridson, 1987) are included in our analyses due to lack of material; on the other hand, the fact that they all bear the typical paired bracts of *Pyrostria* indicates that they belong to this genus. The present study further supports the decision of Bridson (1987) to merge the African genus *Dinocanthium* in *Pyrostria*. Bridson (1987: 614) stressed that both *Leroya* and *Neoleroya* "appeared to be little more than *Pyrostria* with marked

elaboration of the fruit" and therefore were "marginally worth generic rank." Bridson's statement is further supported by our analyses, as *Leroya* and *Neoleroya* are both nested in the *Pyrostria* clade. In addition, the inclusion of *Canthium* sect. *Psydracium* Baill. (Baillon, 1879), represented here by *Pyrostria media* (A. Rich.) Cavaco and *P. major* (A. Rich.) Cavaco, in *Pyrostria* by Cavaco (1967) is supported by our results. Furthermore, our results reveal no support for the two sections of *Pyrostria*, *Pyrostria* sect. *Pyrostria* and *Pyrostria* sect. *Involucratae* Cavaco, described by Cavaco (1971b). *Pyrostria andilanensis* Cavaco, one of the two species of *Pyrostria* sect. *Involucratae* (Cavaco, 1971b), is deeply nested in the members of *Pyrostria* sect. *Pyrostria*, consistent with morphological data. Finally, Bridson's (1987) consideration of grouping *Pyrostria* s. str., *Leroya*, *Neoleroya*, *Pyrostria* group A, *Pyrostria* group B, *Scyphochlamys*, *Cyclophyllum*, her group IV (Bridson, 1987), and group V (*Peponidium* and the Comorean, Malagasy, and Seychellean *Canthium*) under *Pyrostria* is not supported as monophyletic unless *Bullockia* is also included. *Pseudopeponidium* (Bridson, 1987; Schatz, 2001), *Leroya*, and *Neoleroya* have been synonymized under *Pyrostria* by Schatz (2001).

New generic limits of the dioecious group

The present analyses indicate that the generic limits in the dioecious group sensu Razafimandimbison et al. need to be recircumscribed. Our intention is to recognize both monophyletic and morphologically distinct genera and to minimize nomenclatural changes. At least three alternative solutions are possible. The first solution is to maintain *Cyclophyllum* at the generic level and recognize a broader circumscription of *Pyrostria* (the oldest name) including all species of the *Bullockia*, *Peponidium*, and *Pyrostria* clades without infrageneric subdivision. The second solution is to merge the four clades with *Pyrostria*. Both alternatives would make *Pyrostria* rather heterogeneous morphologically and require a large number of new combinations. The third possibility is to recognize the *Cyclophyllum*, *Bullockia*, *Peponidium*, and *Pyrostria* clades all at the generic level. We favor this last option because it reflects the morphological distinctness of the four clades and would minimize nomenclatural changes in the last three clades. In addition, the present study clearly shows that the generic status of *Dinocanthium*, *Leroya*, *Neoleroya*, and *Pseudopeponidium* is untenable. We disregard the possibility of maintaining the current generic status of *Scyphochlamys* because this would force us not only to recognize *Pyrostria* in a narrow sense (i.e., including only the Mascarene species), but also to raise *Dinocanthium* to accommodate

all African and Malagasy *Pyrostria* species. There is no distinctive morphologic character for separating the Mascarene *Pyrostria* from the Afro-Malagasy or Asian ones.

PRELIMINARY BIOGEOGRAPHIC HYPOTHESES OF THE DIOECIOUS GROUP

We are unable to perform a proper biogeographic analysis, as the relationships between the major lineages of the dioecious group as delimited here are largely unresolved. On the other hand, some biogeographic facts can still be discussed for *Bullockia*, *Peponidium* s.l., and *Pyrostria* s.l. A well-resolved phylogeny of the dioecious group based on a much larger sampling is needed to test all biogeographic hypotheses put forward below.

The newly delimited dioecious group is distributed throughout eastern and southern Africa, Southeast Asia, the Indian Ocean islands, the Pacific region, and northern Australia (see also Bridson, 1987). *Bullockia* is an Afro-Malagasy genus, consistent with Bridson's (1987) prediction, which seems to have had an African origin and may well have reached Madagascar via a single long dispersal event. The African species are restricted to eastern and southern Africa (Bridson, 1987) and the two studied Malagasy species are confined, respectively, to the dry deciduous forests of southwestern and northwestern Madagascar. In contrast, our circumscribed *Peponidium* is almost completely Malagasy, with only two to four species restricted to the Comoro Islands (Arènes, 1960; Cavaco, 1972) and two species confined to the Seychelles (Friedmann, 1994). The Comorean and Seychellean species appear to have had Malagasy origins (Fig. 3; Avino et al., unpublished data). In addition, the newly delimited *Pyrostria* is predominantly Malagasy, with 14 species confined to both eastern and southern Africa (Bridson, 1987), eight Mascarene-endemic species (one restricted to Rodrigues Island, five restricted to Mauritius, and two endemic to Réunion Island [Verdcourt, 1983]), and one, *P. bibracteata*, shared between the African mainland, the Comoro Islands, Madagascar, and the Seychelles. The number of species of *Pyrostria* in Southeast Asia is currently unknown. The results further indicate that *P. bibracteata* and the African *Pyrostria*, represented here by *P. hystrix* (Bremek.) Bridson and *P. phyllanthoidea* (Baill.) Bridson, appear to have originated from more than one Malagasy ancestor, as the two sequenced African species do not form a clade (see Fig. 3). Furthermore, the highly supported sister-group relationship (JK – 100, PP – 1.00) between the strongly supported

Mascarene *Pyrostria* (JK – 99, PP – 1.00) and the Rodrigues Island's *Scyphochlamys* indicates that they had a common ancestor (Fig. 3). Geologic evidence suggests that Mauritius emerged as a result of a series of volcanic events, the earliest of which occurred ca. 6.8–7.8 million years ago (Ma). Rodrigues Island did not emerge until 1.5 Ma (McDougall & Chamalaun, 1969), suggesting that the common ancestor of both *Scyphochlamys* and the Mascarene *Pyrostria* should be at least 1.5 Ma. Based on the evidence presented here, it can be concluded that the Mascarene *Pyrostria* and possibly *Pyrostria* s.l. had a relatively recent diversification. This may well be one plausible explanation for the low to moderate support for *Pyrostria* s.l. compared to that of *Bullockia*, *Cyclophyllum*, and *Peponidium* s.l. (Fig. 3).

PHYLOGENETIC CONCLUSIONS

The present study supports a further disintegration of *Canthium* s.l., as the Southeast Asian *C. confertum* and the Comorean and Malagasy *Canthium* species group are distantly related to *Canthium* s. str. (Lantz & Bremer, 2004) and are for the first time shown to belong to the new circumscribed dioecious group. The combined analyses show that the dioecious group can be subdivided into four morphologically distinct clades. According to the rules of priority, the following generic names are applicable to the clades: *Cyclophyllum*, *Bullockia*, *Peponidium*, and *Pyrostria*. *Cyclophyllum* is resolved with high support as sister to the dioecious group sensu Lantz and Bremer (2004). The results further point to a single origin of functional dioecy from hermaphroditism for the newly circumscribed dioecious group followed by subsequent reversals back to the hermaphroditic conditions at least in both *Cyclophyllum* and *Pyrostria* s.l. Furthermore, the Malagasy *Bullockia* species seem to have a common African ancestor, which is most likely to have reached Madagascar via a long dispersal event and subsequently radiated there. In contrast, the Comorean *Peponidium* s.l. appears to have originated from a Malagasy common ancestor. Similarly, our results further support the Malagasy origins of the African *Pyrostria* and a single origin of the Mascarene *Pyrostria*. Finally, we conclude that *Pyrostria* s.l. is a relatively young group that seems to have had a recent diversification.

TAXONOMIC IMPLICATIONS

Below, we formally describe *Bullockia* (Bridson) Razafim., Lantz & B. Bremer to accommodate all six described African species of *Canthium* subgen. *Bullockia* and the two undescribed new Malagasy

species (*Canthium* sp. indet. 5 and 6). We synonymize *Scyphochlamys* with *Pyrostria*. *Dinocanthium*, *Leroya*, *Neoleroya*, and *Pseudopeponidium* all have been synonymized under *Pyrostria* before (Bridson, 1987; Schatz, 2001). Razafimandimbison et al. (2007) have recently transferred 20 species of the Indian Ocean and Comorean *Canthium* to *Peponidium* and all described species of *Leroya*, *Neoleroya*, *Pseudopeponidium*, and *Scyphochlamys* to *Pyrostria*. The transfer of the two Seychellean *Canthium* to *Peponidium* will be published elsewhere.

I. *Bullockia* (Bridson) Razafim., Lantz & B. Bremer, stat. nov. Basionym: *Canthium* subgen. *Bullockia* Bridson, Kew Bull. 42: 630. 1987. TYPE: *Bullockia setiflora* (Hiern) Razafim., Lantz & B. Bremer.

For a description, see Bridson (1987: 630). The only new information we add is that species with persistent (all African members) and deciduous leaves (the two new undescribed Malagasy species; see Figs. 1–3) are found in *Bullockia*.

Number of species. There are at least eight species (six species in mainland Africa [Bridson, 1987] and two in Madagascar).

Distribution and habitat. The genus is distributed in eastern and southern Africa and Madagascar in bushland, woodland, savannas, and dry, deciduous forests.

Diagnostic features. *Bullockia* is distinct from the other functionally dioecious genera of Vanguerieae by the combination of the following characters: the inside of the corolla tube with a well-defined ring of deflected hairs; corolla-throat pubescent but not congested with hairs, rarely fleshy corollas; dorsal face of the anthers with only the central area with a dark connective or entirely without a dark connective; and a hollow stigmatic knob (at least near the base) with a recessed style (Bridson, 1987).

New combinations. Here, we transfer all described species of *Canthium* subgen. *Bullockia*.

1. *Bullockia dyscriton* (Bullock) Razafim., Lantz & B. Bremer, comb. nov. Basionym: *Canthium dyscriton* Bullock, Bull. Misc. Inform. Kew 1936: 478. 1936. TYPE: Kenya. Teita Distr.: Teita Hills, 2500–3500 ft., s.d., *H. M. Gardner 3000* (holotype, K not seen, photo!).

2. *Bullockia fadenii* (Bridson) Razafim., Lantz & B. Bremer, comb. nov. Basionym: *Canthium fadenii* Bridson, Kew Bull. 42: 632. 1987. TYPE: Kenya. Kiambu Distr.: “behind Blue Ports Hotel,

Thika,” 4900 ft., 23 Mar. 1968, *R. B. Faden 68/012* (holotype, K not seen, photo!).

3. *Bullockia impressinervia* (Bridson) Razafim., Lantz & B. Bremer, comb. nov. Basionym: *Canthium impressinervium* Bridson, Kew Bull. 42: 633. 1987. TYPE: Tanzania. Lindi Distr., “Noto-Plateau,” ca. 450 m, 9 Mar. 1937, *H. J. Schieben 6109* (holotype, K not seen, photo!).

4. *Bullockia mombazensis* (Baill.) Razafim., Lantz & B. Bremer, comb. nov. Basionym: *Canthium mombazense* Baill., Adansonia 12: 188. 1879. TYPE: Kenya. “Côte orientale d’Afrique: Zanzibar,” 1847–1852, *L. H. Boivin s.n.* (holotype, P!).

5. *Bullockia pseudosetiflora* (Bridson) Razafim., Lantz & B. Bremer, comb. nov. Basionym: *Canthium pseudosetiflorum* Bridson, Kew Bull. 42: 635. 1987. TYPE: Kenya. “Among granite rocks by watercourse,” 3400 ft., 1952–1953, *J. B. Gillett 14096* (holotype, K not seen, photo!).

6. *Bullockia setiflora* (Hiern) Razafim., Lantz & B. Bremer, comb. nov. Basionym: *Canthium setiflorum* Hiern, Fl. Trop. Afr. [Oliver et al.] 3: 134. 1877. TYPE: Mozambique. “Between Tete and the sea coast,” Mar.–Apr. 1860, *J. Kirk s.n.* (holotype, K not seen, photo!).

II. *Peponidium* (Baill.) Arènes, Notul. Syst. (Paris) 16: 25. 1960. Basionym: *Canthium* sect. *Peponidium* Baill., Adansonia 12: 197. 1879. TYPE: *Peponidium horridum* (Baill.) Arènes.

For a description, see Arènes (1960).

Number of species. There are at least 45 species, all (except two to four Comorean species [Arène, 1960] and two Seychellean species [Friedmann, 1994]) endemic to Madagascar (Arènes, 1960; Razafimandimbison et al., 2007).

Distribution and habitat. This genus occurs in Madagascar (e.g., Arènes, 1960; Cavaco, 1969b), the Comoro Islands (Arènes, 1960; Mouly, 2007), and the Seychelles (Friedmann, 1994) in dry, deciduous forests, lowland rainforests, and mid- and high-altitude humid forests.

Diagnostic features. Our newly circumscribed *Peponidium* is diagnosed by the presence of deciduous, cupular bracts at the bases of the inflorescence peduncles that never enclose the young inflorescence.

III. *Pyrostria* Comm. ex. Juss., Gen. Pl. 206. 1789. TYPE: *Pyrostria commersonii* J. F. Gmel.

Scyphochlamys Balf. f., J. Linn. Bot. 16: 14–15. 1877, syn. nov. TYPE: *Scyphochlamys revoluta* Balf. f.

- Canthium* sect. *Psydracium* Baill., *Adansonia* 12: 199. 1879.
TYPE: *Pyrostria major* (A. Rich.) Cavaco [– *Psydrax major* A. Rich.].
- Dinocanthium* Bremek., *Ann. Transvaal Mus.* 15: 259. 1933.
TYPE: *Dinocanthium hystrix* Bremek.
- Pseudopeponidium* Homolle ex Arènes, *Notul. Syst. (Paris)* 16: 19. 1960. TYPE: *Pseudopeponidium neriifolium* Homolle ex Arènes.
- Leroya* Cavaco, *Adansonia*, n.s., 10: 335. 1970. TYPE: *Leroya madagascariensis* Cavaco.
- Neoleroya* Cavaco, *Adansonia*, n.s., 11: 122. 1971. TYPE: *Neoleroya verdcourtii* Cavaco.
- Pyrostria* sect. *Involucratae* Cavaco, *Adansonia*, n.s., 11: 393. 1971. TYPE: *Pyrostria amporoforensis* Cavaco.

For a description, see Bridson (1987).

Number of species. There are at least 80 species (55 species in Madagascar [Govaert et al., 2006; Davis et al., 2007; Lantz et al., 2007; Razafimandimbison et al., 2007], plus at least eight new undescribed species there, with 14 species on mainland Africa [Bridson, 1987; Verdcourt & Bridson, 1991], and eight on the Mascarenes [Verdcourt, 1983]). The number of species in Southeast Asia is currently unknown.

Distribution and habitat. The genus occurs on the Comoro Islands, Madagascar, the Mascarenes, the Seychelles, eastern and southern Africa, and Southeast Asia in dry, deciduous forests, thicket xerophyllous forests, lowland rainforests, and both mid- and high-altitude and humid forests.

Diagnostic features. Our newly circumscribed *Pyrostria* can be easily distinguished from the other genera of the dioecious group by its persistent, basally connate, and long acuminate paired bracts, which are relatively large and spathe-like in *Scyphochlamys revoluta*.

Literature Cited

- Achille, F. 2006. *Tinadendron*, a new genus of Rubiaceae, Guettardeae from eastern Melanesia. *Adansonia* 28: 167–180.
- , T. J. Motley, P. P. Lowry II & J. Jérémie. 2006. Polyphyly in *Guettarda* L. (Rubiaceae, Guettardeae) based on nrDNA ITS sequence data. *Ann. Missouri Bot. Gard.* 93: 103–121.
- Akaike, H. 1974. A new look at the statistical model identification. *IEEE Trans. Automatic Control* 19: 716–723.
- Alejandro, G. D., S. G. Razafimandimbison & S. Liedt-Schumann. 2005. Polyphyly of *Mussaenda* inferred from ITS and *trnT-F* data and its implication for generic limits in Mussaendeae (Rubiaceae). *Amer. J. Bot.* 92: 544–557.
- Andreasen, K., B. G. Baldwin & B. Bremer. 1999. Phylogenetic utility of the nuclear rDNA ITS region in subfamily Ixoroideae (Rubiaceae): Comparisons with cpDNA *rbcL* sequence data. *Pl. Syst. Evol.* 217: 119–135.
- Arènes, J. 1960. A propos de quelques genres Malgaches de Rubiacées (Vanguériées et Gardeniées). *Notul. Syst. (Paris)* 16: 6–41.
- Baillon, H. 1879. Mémoire sur les genres *Canthium* et *Hypobathrum*. *Adansonia* 12: 179–213.
- Baker, H. G. 1958. Studies in the reproductive biology of West African Rubiaceae. *J. W. African Sci. Assoc.* 4: 9–24.
- & P. A. Cox. 1984. Further thought on dioecism and islands. *Ann. Missouri Bot. Gard.* 71: 244–253.
- Baldwin, B. G. & S. Markos. 1998. Phylogenetic utility of external transcribed spacer (ETS) of 18S–26S rDNA: Congruence of ETS and ITS trees of *Calycadenia* (Compositae). *Molec. Phylogen. Evol.* 10: 449–463.
- Balfour, I. B. 1877. Phanerogamic vegetation of Rodriguez. *J. Linn. Bot.* 16: 14–15.
- Balkwill, K., J. R. Sebola & E. R. Robinson. 1996. Sex expression in *Canthium mundianum* (Rubiaceae). Pp. 650–655 in L. J. G. van der Maesen, V. D. Burgt & J. M. van Medenbach de Rooy (editors), *The Biodiversity of African Plants*. Kluwer Academic Publishers, Dordrecht.
- Beach, J. H. & K. S. Bawa. 1980. Roles of pollinators in the evolution of dioecy from distyly. *Evolution* 34: 1138–1142.
- Bremekamp, C. E. B. 1933. New or otherwise noteworthy plants from northern Transvaal. *Ann. Transvaal Mus.* 15: 259.
- Bremer, B. & J. F. Manen. 2000. Phylogeny and classification of the subfamily Rubioideae (Rubiaceae). *Pl. Syst. Evol.* 211: 71–92.
- , R. J. Jansen, B. Oxelman, M. Backlund, H. Lantz & K.-J. Kim. 1999. More characters or more taxa for a robust phylogeny—Case study from the coffee family (Rubiaceae). *Syst. Biol.* 48: 413–435.
- Bridson, D. M. 1987. Studies in African Rubiaceae-Vanguerieae: A new circumscription of *Pyrostria* and a new subgenus, *Canthium* subgen. *Bullockia*. *Kew Bull.* 42: 611–639.
- . 1992. The genus *Canthium* (Rubiaceae-Vanguerieae) in tropical Africa. *Kew Bull.* 47: 353–401.
- . 1998. Rubiaceae (tribe Vanguerieae). Pp. 211–377 in G. V. Pope (editor), *Flora Zambesiaca*. Royal Botanic Gardens, Kew.
- Burck, M. W. 1883. Sur l'organisation florale chez quelques Rubiacées. Suite. *Ann. Jard. Bot. Buitenzorg* III: 109.
- . 1884. Sur l'organisation florale chez quelques Rubiacées. Suite. *Ann. Jard. Bot. Buitenzorg* IV: 27–29.
- Burger, W. & C. M. Taylor. 1993. *Flora Costaricensis*. Family #202. Rubiaceae. *Fieldiana* 33: 1–333.
- Capuron, R. 1969. A propos des Rubiacées-Vanguériées de Madagascar. *Adansonia*, n.s., 9: 47–55.
- Cavaco, A. 1966. Contribution à l'étude des Vanguériées (Rubiaceae) de Madagascar. *Bull. Mus. Natl. Hist. Nat.* 38: 700–702.
- . 1967. *Pyrostria pseudocommersonii* et *Pseudopeponidium antsalovense* (Rubiaceae-Vanguériées) espèces nouvelles de Madagascar. *Adansonia*, n.s., 7: 39–42.
- . 1968. Espèces nouvelles de Rubiacées de Madagascar. *Bull. Mus. Natl. Hist. Nat.* 39: 1015–1019.
- . 1969a. Contribution à l'étude des Vanguériées (Rubiaceae) de Madagascar. *Bull. Mus. Natl. Hist. Nat.* 41: 372–374.
- . 1969b. Contribution à l'étude des genres *Pseudopeponidium* et *Peponidium* Vanguériées (Rubiaceae) de Madagascar. *Adansonia*, n.s., 9: 43–46.
- . 1970. *Leroya*, nouveau genre de Rubiaceae. *Adansonia*, n.s., 10: 333–337.
- . 1971a. *Neoleroya*, nouveau genre de Rubiaceae-Vanguerieae. *Adansonia*, n.s., 11: 119–123.
- . 1971b. Remarques sur quelques *Pyrostria* de Madagascar. *Adansonia*, n.s., 11: 393–396.

- . 1972. Les *Canthium* et les *Rytigynia* (Rubiaceae) de Madagascar; Affinités avec les espèces Africaines; Nouveaux taxa et combinaisons nouvelles. *Portugaliae Acta Biol., Sér. B, Sist.* 11: 219–247.
- Chase, M. W. & H. H. Hills. 1991. Silica gel: An ideal material for preservation of leaf samples for DNA studies. *Taxon* 40: 215–220.
- Davis, A. P., R. Govaerts & D. M. Bridson. 2007. New combinations in Madagascan Vanguerieae (Rubiaceae) for the genera *Psydrax*, *Pyrostria*, and *Rytigynia*. *Blumea* 52: 139–145.
- Delprete, P. G. 1999. Rubiaceae (part 3) Tribe 7. Condamineae. Pp. 5–53 in G. Harling & L. Andersson (editors), *Flora of Ecuador*, Vol. 62 (7). Göteborg University, Göteborg; Riksmuseum, Stockholm; and Pontificia Universidad Católica del Ecuador, Quito.
- . 2000. *Melanopsidium* Colla (Rubiaceae, Gardenieae): A monospecific Brazilian genus with a complex nomenclatural history. *Brittonia* 52: 325–336.
- Doyle, J. J. & J. L. Doyle. 1987. A rapid DNA isolation procedure for small quantities of fresh leaf tissue. *Phytochem. Bull.* 19: 11–15.
- Farris, J. S. 1989. The retention index and the rescaled consistency index. *Cladistics* 5: 417–419.
- , M. Källersjö, A. G. Kluge & C. Bult. 1995. Testing significance of incongruence. *Cladistics* 10: 315–319.
- Friedmann, F. 1994. Flore des Seychelles. Dicotylédones. Edition de l'ORSTOM, Institut Français de Recherche scientifique pour le Développement en Coopération, Paris.
- Govaerts, R., L. Andersson, E. Robbrecht, D. Bridson, D. Davis, I. Schanzer & B. Sonké. 2006. World Checklist of Rubiaceae. The Board of Trustees of the Royal Botanic Gardens, Kew.
- Guillaumin, A. 1930. Matériaux pour la Flore de la Nouvelle-Calédonie. XXVII. Révision des Rubiacées. P. 48 in A. Guillaumin (editor), *Archives de Botanique*. Tome 3, Mém. 5. Société des Editeurs du Nord, Caen, France.
- Gustafsson, C. & C. Persson. 2002. Phylogenetic relationships among species of the neotropical genus *Randia* (Rubiaceae, Gardenieae) inferred from molecular and morphological data. *Taxon* 51: 661–674.
- Hamilton, C. W. 1990. Variations on a distylous theme in Mesoamerican *Psychotria* subgenus *Psychotria* (Rubiaceae). *Mem. New York Bot. Gard.* 55: 62–75.
- Harris, J. G. & M. W. Harris. 1994. *Plant Identification Terminology*. Spring Lake Publishing, Spring Lake, Utah.
- Heilbuth, J. C. 2000. Lower species richness in dioecious clades. *Amer. Naturalist* 156: 221–241.
- Hooker, J. D. 1873. Ordo LXXXIV. Rubiaceae. Addenda et Corrigenda. Pp. 535–536 in G. Bentham & J. D. Hooker (editors), *Genera plantarum ad exemplaria imprimis in herbariis kewensibus servata defirmata*, Vol. 2, Pt. 1. Reeve & Co., London.
- Huelsenbeck, J. P. & F. Ronquist. 2001. MrBayes: Bayesian inference of phylogenetic trees. *Bioinformatics* 17: 754–755.
- Jussieu, A. L. 1789. *Genera Plantarum Secundum Ordines Naturales Disposita*. Paris.
- Kluge, A. & J. S. Farris. 1969. Quantitative phyletics and the evolution of anurans. *Syst. Zool.* 18: 1–32.
- Lantz, H. & B. Bremer. 2004. Phylogeny inferred from morphology and DNA data: Characterizing well-supported groups in Vanguerieae (Rubiaceae). *Bot. J. Linn. Soc.* 146: 257–283.
- & ———. 2005. Phylogeny of the complex Vanguerieae (Rubiaceae) genera *Fadogia*, *Rytigynia*, and *Vangueria* with close relatives and a new circumscription of *Vangueria*. *Pl. Syst. Evol.* 253: 159–183.
- , K. Andreasen & B. Bremer. 2002. Nuclear rDNA ITS used to construct the first phylogeny of Vanguerieae (Rubiaceae). *Pl. Syst. Evol.* 230: 173–187.
- , J. Klackenberg, S. G. Razafimandimbison & A. Mouly. 2007. Three new species of Vanguerieae (Rubiaceae). *Adansonia, sér. 3*, 29: 129–136.
- Leroy, J. F. 1972. La notion de genre et l'évolution: Sur un cas remarquable de différenciation explosive chez les Rubiacées-Vangueriées à Madagascar. *Compt. Rend. Acad. Sci. Paris* 274: 1682–1685.
- Litrico, I., T. Pailler & J. D. Thompson. 2005. Gender variation and primary succession in a tropical woody plant, *Antirhea borbonica* (Rubiaceae). *Ecology* 93: 705–715.
- Mayer, S. S. & D. Charlesworth. 1991. Cryptic dioecy in flowering plants. *Trends Ecol. Evol.* 10: 320–325.
- McDougall, I. & F. H. Chamalaun. 1969. Isotopic dating and geomagnetic polarity studies on volcanic rocks from Mauritius, Indian Ocean. *Geol. Soc. Amer. Bull.* 80: 1419–1442.
- Mouly, A. 2007. Étude systématique des Rubiaceae de Mayotte et des Comores. Rapport d'expertise à la Direction de l'Agriculture et de la Forêt, Préfecture de Mayotte.
- , S. G. Razafimandimbison, F. Achille, T. Haevermans & B. Bremer. 2007. Phylogenetic placement of *Rhopalobrachium* (Rubiaceae: Ixoroideae): Evidence from molecular (*rps16* and *trnT-F*) and morphological data. *Syst. Bot.* 32: 872–882.
- Naiki, A. & M. Kato. 1999. Pollination system and evolution of dioecy from distyly in *Mussaenda parviflora* (Rubiaceae). *Pl. Spec. Biol.* 14: 217–227.
- Nepokroeff, M., K. J. Systma, W. L. Wagner & E. A. Zimmer. 2003. Reconstructing ancestral patterns of colonization and dispersal in the Hawaiian understory tree genus *Psychotria* (Rubiaceae): A comparison of parsimony and likelihood approaches. *Syst. Biol.* 52: 820–838.
- Nylander, J. A. A. 2004. MrModeltest 2.0. Program distributed by the author. Evolutionary Biology Centre, Uppsala University, Uppsala.
- Osunkoya, O. O. 2003. Two-sex population projection of the endemic and dioecious rainforest shrub, *Gardenia actinocarpa* (Rubiaceae). *Biol. Conservation* 114: 39–51.
- Pailler, T., L. Humeau, J. Figier & J. D. Thompson. 1995. Reproductive trait variation in the functionally dioecious and morphologically heterostylous island endemic *Chasalia corallioides*. *Biol. J. Linn. Soc.* 64: 297–313.
- , ——— & F. Langlade. 1998. Cryptic dioecy in *Bertiera borbonica* var. *borbonica* (Rubiaceae), an endemic species of La Réunion Island. *Acta Bot. Gallica* 145: 29–38.
- Percy, D. M. & Q. C. B. Cronk. 1997. Conservation in relation to mating system in *Nesohedyotis arborea* (Rubiaceae), a rare endemic tree from St. Helena. *Biol. Conservation* 80: 135–145.
- Persson, C. 2000. Phylogeny of the Neotropical *Alibertia* group (Rubiaceae), with emphasis on the genus *Alibertia*, inferred from ITS and 5S ribosomal DNA sequences. *Amer. J. Bot.* 87: 1018–1028.
- . 2003. *Agouticarpa*, a new neotropical genus of Tribe Gardenieae (Rubiaceae). *Brittonia* 55: 176–201.
- Popp, M. & B. Oxelman. 2001. Inferring the history of the polyploid *Silene aegaea* (Caryophyllaceae) using plasmid and homoeologous nuclear DNA sequences. *Molec. Phylogenet. Evol.* 20: 474–481.
- Puttock, C. F. 1999. Revision of *Atractocarpus* (Rubiaceae: Gardenieae) in Australia and new combinations for some extra-Australian taxa. *Austral. Syst. Bot.* 12: 271–309.

- Rambaut, A. 1996. Se-AL: Sequence Alignment Editor (Vers. 1.0d). Available at <http://tree.bio.ed.ac.uk/software/seal/>.
- Razafimandimbison, S. G. & B. Bremer. 2001 [2002]. Tribal delimitations of Naucleaeae (Cinchonoideae, Rubiaceae): Inference from molecular and morphological data. *Syst. & Geogr. Pl.* 71: 515–538.
- & ———. 2002. Phylogeny and classification of Naucleaeae (Rubiaceae) inferred from molecular (ITS, *rbcL*, and *trnT-F*) and morphological data. *Amer. J. Bot.* 89: 1027–1041.
- , E. A. Kellogg & B. Bremer. 2004. Recent origin and phylogenetic utility of divergent ITS putative pseudogenes: A case study from Naucleaeae (Rubiaceae). *Syst. Biol.* 53: 177–192.
- , J. Moog, H. Lantz, U. Maschwitz & B. Bremer. 2005. Re-assessment of monophyly, evolution of mymecophytism, and rapid radiation in *Neonauclea* s.s. (Rubiaceae). *Molec. Phylogenet. Evol.* 34: 334–354.
- , H. Lantz & B. Bremer. 2007. New combinations and names in *Peponidium* and *Pyrostria* (Rubiaceae, Vanguerieae). *Novon* 17: 516–521.
- Renner, S. S. & R. E. Ricklefs. 1995. Dioecy and its correlates in the flowering plants. *Amer. J. Bot.* 82: 596–606.
- Robbrecht, E. 1979. The African genus *Tricalysia* A. Rich (Rubiaceae-Coffeae): A revision of subgenus *Empogoma*. *Bull. Nat. Plantentuin Belg.* 49: 239–360.
- . 1988. Tropical woody Rubiaceae. Characteristic features and progressions. Contributions to a new subfamilial classification. *Opera Bot. Belg.* 1: 1–272.
- Saghai-Maroo, K. M., M. Soliman, R. A. Jorgensen & R. W. Allard. 1984. Ribosomal DNA spacer length polymorphism in barley: Mendelian inheritance, chromosomal location, and population dynamics. *Proc. Natl. Acad. Sci. U.S.A.* 81: 8014–8018.
- Sakai, A. K., W. L. Wagner, D. M. Fergurson & D. R. Herbst. 1995. Origins of dioecy in the Hawaiian flora. *Ecology* 76: 2517–2529.
- Schatz, G. E. 2001. Generic Tree Flora of Madagascar. Royal Botanic Gardens, Kew, and Missouri Botanical Garden, St. Louis.
- Skottsberg, C. J. 1922. Catalogue of Easter Island phanerogams. Pp. 63–84 in *Natural History of Juan Fernandez and Easter Island*, Vol. 2. Almqvist & Wiksells, Uppsala.
- . 1944. On the flower dimorphism in Hawaiian Rubiaceae. *Ark. Bot.* 31A(4).
- . 1945. The flower of *Canthium*. *Ark. Bot.* 32A(5).
- Simmons, M. P. & H. Ochoterena. 2000. Gaps as characters in sequence-based phylogenetic analyses. *Syst. Biol.* 49: 369–381.
- Smith, A. C. & S. P. Darwin. 1988. Family 168. Rubiaceae. Pp. 146–362 in A. C. Smith (editor), *Flora Vitiensis Nova. A New Flora of Fiji (spermatophytes only)*, Vol. 4—Angiospermae: Dicotyledones, Families. Pacific Tropical Botanical Garden, Kauai, Hawaii.
- Staden, R. 1996. The Staden sequence analysis package. *Molec. Biotech.* 5: 233–241.
- Swofford, D. L. 2000. PAUP*: Phylogenetic Analysis Using Parsimony (* and Other Methods), Vers. 4.0b. Sinauer, Sunderland, Massachusetts.
- Thompson, A. J. D., D. G. Higgins & T. G. Gibson. 1997. CLUSTAL W: Improving the sensitivity of progressive multiple sequence alignment through sequence weighting, position specific gap penalties and weight matrix choice. *Nucl. Acids Res.* 22: 4673–4680.
- van Beusekom, C. F. 1967. A revision of the Malesian and Ceylonese species of the genus *Gaertnera* Lamk. (Rubiaceae). *Blumea* 2: 359–391.
- Verdcourt, B. 1958. Remarks on the classification of the Rubiaceae. *Bull. Jard. Bot. État Bruxelles* 28: 209–281.
- . 1983. Notes on Mascarenes Rubiaceae. *Kew Bull.* 37: 563–570.
- & B. Bridson. 1991. *Canthium*. Pp. 861–885 in R. M. Polhill (editor), *Flora of Tropical East Africa*. Balkema, Leiden.
- Wagner, W. L. & D. H. Lorence. 1998. A new, dioecious species of *Hedyotis* (Rubiaceae) from Kaua'i, Hawaiian Islands, and the taxonomy of *Hedyotis schlechtendahlana* resolved. *Novon* 8: 311–317.
- Weiblen, G. D., R. K. Oyama & M. J. Donoghue. 2000. Phylogenetic analysis of dioecy in monocotyledons. *Amer. Naturalist* 155: 46–58.
- Wong, K. M. 1984. A synopsis of *Morinda* (Rubiaceae) in the Malay Peninsula, with two new species. *Malayan Nat. J.* 38: 89–98.
- Yang, Z. 1994. Maximum likelihood phylogenetic estimation from DNA sequences with variable rates over sites: Approximate methods. *J. Molec. Evol.* 39: 306–314.

Appendix 1. List of the investigated sequenced taxa, voucher information, country origins, and accession numbers.

Taxa	Voucher information	Country of origin	ETS	ITS
<i>Afrocanthium pseudovorticillatum</i> (S. Moore) Lantz	Lantz & Bremer (2004)			AJ617758
<i>Afrocanthium siebenlistii</i> (K. Krause) Lantz	Lantz & Bremer (2004)			AJ617759
<i>Alberta magna</i> E. Mey.	Andreassen et al. (1999)			AJ224842
<i>Ancylanthos rubiginosus</i> Desf. (specimen A)	Lantz & Bremer (2004)	Thailand		AJ617747
<i>Canthium confertum</i> Korth.	<i>Mold Shad & Maxwell 3962</i> (AAU)			EU584288
<i>Canthium cystiporon</i> Bynum ex Cavaco	<i>Labat et al. 3280</i> (P)	Mayotte Island	EU584363	EU584299
<i>Canthium fadenii</i> Bridson	<i>Luke 9014</i> (UPS)	Kenya	EU584319	EU584260
<i>Canthium inerme</i> Kuntze	Lantz et al. (2002); Lantz & Bremer (2004)			AJ315120
<i>Canthium marojjyense</i> Cavaco	<i>Razafimandimbison & Ravelonarivo 589</i> (S)	Madagascar	EU584377	EU584308
<i>Canthium mombazense</i> Baill.	<i>Mwangoka et al. 3375</i> (S)	Kenya	EU584320	EU584261
<i>Canthium pseudositiflorum</i> Bridson	Lantz & Bremer (2004)		EU584322	AJ617757
<i>Canthium</i> Lam. sp. indet. 1	<i>Eriksson et al. 1020</i> (S)	Madagascar	EU584376	EU584307
<i>Canthium</i> sp. indet. 2	<i>Kårehed et al. 210</i> (UPS)	Madagascar	EU584358	EU584292
<i>Canthium</i> sp. indet. 3	<i>Noyes et al. 1063</i> (MO)	Madagascar	EU584342	EU584278
<i>Canthium</i> sp. indet. 4	<i>Kårehed et al. 204</i> (UPS)	Madagascar	EU584359	EU584293
<i>Canthium</i> sp. indet. 5	<i>Davis & Rakotonasolo 2576</i> (K)	Madagascar	EU584324	EU584254
<i>Canthium</i> sp. indet. 6	<i>De Block et al. 1100</i> (BR)	Madagascar	EU584325	EU584265
<i>Canthium</i> sp. indet. 7	<i>Davis 1193</i> (K)	Madagascar	EU584323	EU584263
<i>Canthium</i> sp. indet. 8	<i>Davis 1020</i> (K)	Madagascar	EU584321	EU584262
<i>Canthium</i> sp. indet., aff. <i>confertum</i>	<i>Maxwell 77-128</i> (AAU)	Thailand		EU584289
<i>Canthium venulosum</i> Boivin ex Baill.	<i>Pignat 1825</i> (P)	Mayotte Island	EU584368	EU584301
<i>Cyclophyllum balansae</i> (Baill.) Guillaumin	<i>Mouly 181</i> (P)	New Caledonia	EU584357	EU584290
<i>Cyclophyllum barbata</i> (G. Forst.) N. Hallé & J. Florence	Lantz & Bremer (2004)		EU584356	AJ617760
<i>Hutchinsonia barbata</i> Robyns	Lantz et al. (2002); Lantz & Bremer (2004)			AJ315102
<i>Ixora coccinea</i> L.	Andreassen et al. (1999)			AJ224826
<i>Keetia venosa</i> (Oliv.) Bridson	Lantz & Bremer (2004)			AJ617762
<i>Leroya</i> Cavaco sp. indet.	<i>De Block et al. 1143</i> (BR)	Madagascar	EU584327	EU584266
<i>Leroya</i> sp. indet., aff. <i>richardiae</i> Cavaco	Lantz & Bremer (2004)		EU584326	AJ617763
<i>Multidentia conrescens</i> (Bullock) Bridson & Verdc.	Lantz et al. (2002)			AJ315086
<i>Multidentia sclerocarpa</i> (K. Schum.) Bridson	Lantz & Bremer (2005)			AJ874986
<i>Neoleroya verdcourtii</i> Cavaco	Lantz & Bremer (2004)		EU584328	AJ617764
<i>Peponidium buxifolium</i> (Baker) Razafim., Lantz & B. Bremer, acc. 1	<i>Eriksson et al. 908</i> (S)	Madagascar	EU584371	EU584303
<i>Peponidium buxifolium</i> (Baker) Razafim., Lantz & B. Bremer, acc. 2	<i>Eriksson et al. 909</i> (S)	Madagascar	EU584370	EU584302
<i>Peponidium buxifolium</i> (Baker) Razafim., Lantz & B. Bremer, acc. 3	<i>Eriksson et al. 919</i> (S)	Madagascar	EU584373	EU584305
<i>Peponidium buxifolium</i> (Baker) Razafim., Lantz & B. Bremer, acc. 4	<i>Eriksson et al. 920</i> (S)	Madagascar	EU584374	EU584311

Appendix 1. Continued.

Taxa	Voucher information	Country of origin	ETS	ITS
<i>Peponidium crassifolium</i> Lantz, Klack. & Razafim.	<i>Razafimandimbison & Ravelonarivo 628 (S)</i>	Madagascar	EU584381	EU584313
<i>Peponidium horridum</i> (Baill.) Arènes	<i>Razafimandimbison & Razafimanantsoa 470 (UPS)</i>	Madagascar	EU584329	EU584267
<i>Peponidium madagascariense</i> Cavaco	<i>Razafimandimbison & Andrianatoanina 431 (UPS)</i>	Madagascar	EU584330	EU584268
<i>Peponidium</i> Arènes sp. indet. 1	<i>Eriksson et al. 1009 (S)</i>	Madagascar	EU584375	EU584306
<i>Peponidium</i> sp. indet. 2	<i>Kårehed et al. 260 (UPS)</i>	Madagascar	EU584362	EU584296
<i>Peponidium</i> sp. indet. 3	<i>Bremer et al. 4046-B46 (UPS)</i>	Madagascar	EU584332	EU584269
<i>Peponidium</i> sp. indet. 4	<i>Davis 1133 (K)</i>	Madagascar	EU584333	EU584270
<i>Peponidium</i> sp. indet. 5	<i>Davis 1028 (K)</i>	Madagascar	EU584334	EU584271
<i>Peponidium</i> sp. indet. 6 clone 1	<i>Razafimandimbison & Andrianatoanina 458 (TAN)</i>	Madagascar	EU584338	EU584273
clone 2			EU584339	EU584274
clone 3			EU584275	EU584275
<i>Peponidium</i> sp. indet., aff. <i>buxifolium</i> (Baker) Razafim., Lantz & B. Bremer	<i>Razafimandimbison 561 (TAN)</i>	Madagascar	EU584367	EU584300
<i>Peponidium</i> sp. indet., aff. <i>madagascariense</i>	<i>Kårehed et al. 223 (UPS)</i>	Madagascar	EU584317	EU584384
<i>Peponidium velutinum</i> Arènes	<i>Callmander 331 (MO)</i>	Madagascar	EU584331	EU584314
<i>Pseudopeponidium ampjoroense</i> Arènes	Lantz & Bremer (2004)		EU584335	AJ617766
<i>Pseudopeponidium asosa</i> Arènes	Lantz & Bremer (2004)		EU584337	EU584272
<i>Pseudopeponidium ixorifolium</i> Homolle ex Arènes	<i>Kårehed et al. 266 (UPS)</i>	Madagascar	EU584355	EU584291
<i>Pseudopeponidium longiflorum</i> Cavaco	<i>Razafimandimbison 522 (UPS)</i>	Madagascar	EU584361	EU584294
<i>Pseudopeponidium oleifolium</i> Homolle ex Arènes clone 1	<i>Razafimandimbison et al. 422 (TAN)</i>	Madagascar	EU584340	EU584276
clone 2			EU584341	EU584277
<i>Pseudopeponidium</i> Homolle ex Arènes sp. indet. 1	<i>Kårehed et al. 222 (UPS)</i>	Madagascar	EU584361	EU584295
<i>Pseudopeponidium</i> sp. indet. 2	<i>Razafimandimbison 514 (UPS)</i>	Madagascar	EU584364	EU584298
<i>Psydrax kraussioides</i> (Hiern) Bridson	Lantz & Bremer (2004)			AJ617768
<i>Psydrax obovata</i> (Klotzsch ex Eckl. & Zeyh.) Bridson	Lantz & Bremer (2004)		EU584318	AJ315109
<i>Pyrostria parviflora</i> (Afzel.) Bridson subsp. <i>parviflora</i>	Lantz & Bremer (2004)			AJ315110
<i>Pyrostria anditanensis</i> Cavaco	<i>Razafimandimbison & Razafimanantsoa 467 (UPS)</i>	Madagascar	EU584369	
<i>Pyrostria anjouanensis</i> Arènes ex Cavaco	<i>Pignal et al. 1808 (P)</i>	Mayotte Island (France)	EU584366	EU584297
<i>Pyrostria ankazobeensis</i> Arènes ex Cavaco	<i>Davis 1022 (K)</i>	Madagascar	EU584349	EU584284
<i>Pyrostria bibractata</i> (Baker) Cavaco	Lantz et al. (2002); Lantz & Bremer (2004)		EU584365	AJ315113
<i>Pyrostria commersonii</i> J. F. Gmel.	<i>Cadet 728</i> (Herbier Universitaire de La Réunion)	La Réunion Island	EU584353	
<i>Pyrostria hystrix</i> (Bremek.) Bridson	Lantz & Bremer (2004)		EU584343	AJ315114
<i>Pyrostria major</i> (A. Rich.) Cavaco	<i>Eriksson et al. 918 (S)</i>	Madagascar	EU584372	EU584304
<i>Pyrostria media</i> (A. Rich.) Cavaco	<i>Razafimandimbison 511 (UPS)</i>	Madagascar	EU584383	EU584316
<i>Pyrostria orbicularis</i> A. Rich.	<i>Patiller 180</i> (Herbier Universitaire de La Réunion)	La Réunion Island	EU584352	EU584287
<i>Pyrostria pendula</i> Lantz, Klack. & Razafim.	<i>Razafimandimbison & Ravelonarivo 626 (S)</i>	Madagascar	EU584379	EU584310

Appendix 1. Continued.

Taxa	Voucher information	Country of origin	ETS	ITS
<i>Pyrostria phyllanthoidea</i> (Baill.) Bridson	Lantz & Bremer (2004)		EU584344	AJ315115
<i>Pyrostria sarodranensis</i> Cavaco	Phillipson & Rabesihanaka 3177 (MO)	Madagascar	EU584336	EU584280
<i>Pyrostria serpentina</i> Lantz, Klack. & Razafim.	Davis 1162 (K)	Madagascar	EU584348	EU584283
<i>Pyrostria</i> Comm. ex Juss. sp. indet. 1	Rabenantoandro et al. 770 (MO)	Madagascar	EU584345	EU584279
<i>Pyrostria</i> sp. indet. 2	Razafimandimbison & Ravelonarivo 648 (S)	Madagascar	EU584382	EU584315
<i>Pyrostria</i> sp. indet. 3	Eriksson et al. 947 (S)	Madagascar	EU584378	EU584309
<i>Pyrostria</i> sp. indet. 4	Razafimandimbison & Ravelonarivo 594 (S)	Madagascar	EU584380	EU584312
<i>Pyrostria</i> sp. indet. 5	De Block et al. 1117 (BR)	Madagascar	EU584346	EU584281
<i>Pyrostria</i> sp. indet. 6	Razafimandimbison et al. 412 (BR)	Madagascar	EU584347	EU584282
<i>Pyrostria</i> sp. indet. 7	Razafimandimbison & Andrianatoanina 451 (UPS)	Madagascar	EU584350	EU584287
<i>Pyrostria viburnoides</i> (Baker) Verdc.	Andriambololonera s.n. (TAN)	Mauritius	EU584351	EU584286
<i>Robynsia glabrata</i> Hutch.	Lantz & Bremer (2004)			AJ617774
<i>Rytigynia senegalensis</i> Blume	Lantz et al. (2002); Lantz & Bremer (2004)			AJ315104
<i>Scyphochlamys revoluta</i> Balf. f.	Lantz & Bremer (2004)		EU584354	AJ617776
<i>Tapiphyllum cinerascens</i> (Hiern) Robyns	Lantz et al. (2002); Lantz & Bremer (2004)			AJ315096
<i>Vangueria infausta</i> Burch.	Lantz et al. (2002)			AJ315093

THE *RONDELETIA* COMPLEX
(RUBIACEAE): AN ATTEMPT TO
USE ITS, *RPS16*, AND *TRNL-F*
SEQUENCE DATA TO DELIMIT
GUETTARDEAE, RONDELETIEAE,
AND SECTIONS WITHIN
*RONDELETIA*¹

Johan H. E. Rova,² Piero G. Delprete,³ and
Birgitta Bremer⁴

ABSTRACT

In the present study, a molecular phylogeny of the *Rondeletia* L. complex (Rubiaceae, Rondeletieae) was constructed with the following main objectives: (1) to evaluate the sections of *Rondeletia* proposed by Fernández Zequeira; (2) to test if *Stevensia* Poit. belongs to the Rondeletieae s. str.; (3) to check if ITS data from Rondeletieae support previous phylogenetic results from *trnL-F* data regarding circumscription of Rondeletieae; and (4) to verify if *Hodgkinsonia* F. Muell. belongs to Guettardeae or elsewhere. Two analyses were performed, one with ITS sequences from 46 taxa in the Rondeletieae–Guettardeae complex, and the other with combined ITS, *rps16*, and *trnL-F* sequences of 21 taxa. Representatives of nine of the 10 sections of *Rondeletia* recognized by Fernández Zequeira were included in the ITS analysis. Five of her sections could be tested for monophyly. Support was only found for *Rondeletia* sect. *Leoninae* M. Fernández Zeq., while representatives from section *Chamaebuxifoliae* M. Fernández Zeq., section *Hypoleucae* Standl., and section *Nipenses* M. Fernández Zeq. together form a well-supported clade that could be distinguished also based on morphology. The latter clade is sister to *Stevensia*, which is thus placed within *Rondeletia* s. str. In addition, ITS sequence data confirm the separation of *Rovaeanthus* Borhidi from *Rogiera* Planch. Support is low for inclusion of *Blepharidium* Standl., *Mazaea* Krug & Urb., *Phyllomelia* Griseb., *Rachicallis* DC., part of *Rogiera*, and *Suberanthus* Borhidi & M. Fernández Zeq. in Rondeletieae. *Rachicallis*, *Mazaea*, and *Phyllomelia* form a clade with strong support. The tribe Rondeletieae s. str. was found to be monophyletic in all trees, although with low support; however, a re-delimitation of the tribe is proposed here based on this study and previous phylogenetic analyses. The monophyly for the tribe Guettardeae is weakly supported, with the inclusion of *Arachnothryx* Planch. (including *Cuatrecasiodendron* Steyerm.), *Gonzalagunia* Ruiz & Pav., *Hodgkinsonia*, and *Timonius* DC. Although it was recently the subject of a molecular phylogenetic study, the tribe Guettardeae is still in need of a wide-ranging survey in order to confirm its monophyly and delimit its taxonomic boundaries. Because *Cuatrecasiodendron* was found within the *Arachnothryx* clade, the two genera are here synonymized as *Arachnothryx*, and in turn positioned within the tribe Guettardeae. In addition, based on herbarium and field studies, the two species described under *Cuatrecasiodendron* (*C. spectabile* Steyerm. and *C. colombianum* Standl. & Steyerm.) are treated as synonyms to the new combination *Arachnothryx spectabilis* (Steyerm.) Rova, Delprete & B. Bremer, which is proposed here.

Key words: *Arachnothryx*, *Cuatrecasiodendron*, Guettardeae, *Hodgkinsonia*, ITS, phylogeny, *Rogiera*, *Rondeletia*, Rondeletieae, *rps16*, Rubiaceae, *Stevensia*, *trnL-F*.

¹ We are grateful to Attila Borhidi (Janos Pannonius University, Pécs) for help with identification of specimens of *Rondeletia* and related taxa and to Nahid Heidari and the staff at the Evolutionary Biology Centre (Uppsala University) for technical assistance. The National Tropical Botanical Garden, Lawai, Kauai, Hawaii, provided material for *Rondeletia inermis* and *Rovaeanthus strigosus*. This work was supported by a grant from the Bergius Foundation. Part of this research was realized during a Visiting Scientist fellowship to Piero Delprete (PD) from the Conselho Nacional de Desenvolvimento Científico e Tecnológico (CNPq) at the Universidade Federal de Goiás, Goiânia, Goiás, Brazil. PD's fieldwork in Cuba was supported by a grant from the MacArthur Foundation through the American Council of Learned Societies/Social Science Research Council Working Group on Cuba. We also thank the Cuban government for giving permission to PD to perform fieldwork, and Ramona Oviedo, Mayra Fernández, Jaqueline Salazar, and Lazara Sotolongo (Academia de Ciencias, Instituto de Ecología y Sistemática, La Habana, Cuba; HAC) for accompanying PD during fieldwork in 2002.

² Hagaberg Baskarp, SE-566 92 Habo, Sweden. Author for correspondence: jorova@telia.com.

³ CNPq Visiting Scientist, Institute of Biological Sciences–ICB-1, Department of General Biology/Botany, Universidade Federal de Goiás, Campus II, 74001-970 Goiânia, Goiás, Brazil. Current address: Institut de Recherche pour le Développement, Botanique et Bioinformatique de l'Architecture des Plantes (AMAP), TA-A51/PS2, Blvd. de la Lironde, 34398 Montpellier Cedex 5, France. pdelprete@hotmail.com.

⁴ Bergius Foundation at the Royal Swedish Academy of Sciences and Botany Department, Stockholm University, SE-106 91 Stockholm, Sweden.

doi: 10.3417/2006179

The tribe Rondeletieae (Rubiaceae, Cinchonoideae) includes predominantly shrubs and trees and is mostly distributed in the New World tropics (Robbrecht, 1988; Delprete, 1999a), with the main center of diversity in the Greater Antilles. A thorough description of the taxonomic and systematic history of the tribe is found in Delprete (1999a).

The largest genus of the tribe, *Rondeletia* L., is mainly Antillean and comprises approximately 120 species. Standley (1918) divided *Rondeletia* into 15 sections based on morphological and distributional data. Since then, several morphological and molecular studies in the Rondeletieae have argued about the status of Standley's sections and the circumscription of the genus *Rondeletia*. One opinion is that *Rondeletia* should be regarded as a narrowly circumscribed genus, separated from morphologically similar genera such as *Arachnothryx* Planch., *Javorkaea* Borhidi & Jarai-Koml., *Rogiera* Planch., *Roigella* Borhidi & M. Fernández Zeq., *Rovaeanthus* Borhidi, and *Suberanthus* Borhidi & M. Fernández Zeq. (Steyermark, 1967; Borhidi & Fernández Zequeira, 1981a, b; Borhidi, 1982, 1989, 1994; Borhidi & Járαι-Komlódi, 1983; Fernández Zequeira, 1994; Delprete, 1999a, as *Rondeletia* complex sensu Delprete; Rova, 1999; Rova et al., 2002; Borhidi et al., 2004; Rova, unpublished). On the other hand, Lorence (1991) recognized *Rondeletia* as a widely circumscribed genus, treating the names applied to Mexican and Central American taxa of the complex as synonyms. Based on morphological data, Fernández Zequeira (1994) made an attempt to classify the Greater Antillean (especially the Cuban) *Rondeletia* species into 10 sections. Her classification comprised 104 species, most of them endemic to Cuba. This means that a majority of the species of *Rondeletia* s. str. were included in her study. According to Fernández Zequeira (1994), the sections are distinguished by various combinations of (often multistate) morphological characters such as position and shape of inflorescence, flower merosity, calyx lobe shape, leaf indumentum, and phyllotaxy (leaves opposite vs. verticillate). However, her focus on Cuban species did little to resolve the problem in the larger *Rondeletia* complex. The first aim of the present study was to test if Fernández Zequeira's sections of *Rondeletia* are supported by phylogenies obtained from molecular sequences. The second aim was to test if *Stevensia* Poit. was closely related to *Rondeletia* or not. *Stevensia* has not been included previously in molecular phylogenies, but morphology suggests a close affinity between the genera. Earlier studies (Bremer et al., 1995; Bremer & Thulin, 1998; Andersson & Rova, 1999; Rova et al., 2002) have shown that the tribes Guettardeae and Rondeletieae

are closely related, and this study also aimed to investigate if ITS data would suggest a similar circumscription of Rondeletieae as previous studies had. Finally, the study was aimed to investigate if ITS sequence data would support Bremer's (1992) inclusion of the Australian genus *Hodgkinsonia* F. Muell. in the Guettardeae or Delprete's (1996) transfer of the genus from the Guettardeae to the Chiococceae.

MATERIALS AND METHODS

For the ITS analyses, material was sampled from as many *Rondeletia* species and subspecies as possible. An effort was made to include representatives from all genera in Rondeletieae sensu Rova et al. (2002). The outgroup consisted of *Luculia* Sweet (basal in Rubiaceae, e.g., Bremer et al., 1995), *Catesbaea fuertesii* Urb., *Chiococca alba* (L.) Hitchc. (Chiococceae s.l.), and 12 accessions representing 11 species in the following six genera of the tribe Guettardeae (based on available material and the results from Rova et al., 2002): *Arachnothryx*, *Cuatrecasiodendron* Steyerm., *Gonzalagunia* Ruiz & Pav., *Guettarda* L., *Rogiera*, and *Timonius* DC. Authors of species names are given in Table 1, or otherwise when first mentioned in the text.

Fresh or silica gel-dried leaves were used for DNA extraction when available, but often herbarium material had to be used. DNA was extracted using the CTAB method (Doyle & Doyle, 1987) and cleaned with the QIAquick PCR Purification Kit (QIAGEN GmbH, Hilden, Germany). The cocktail for polymerase chain reaction (PCR) amplification was mixed as follows (to ca. 25 μ l): 2.5 μ l 10 \times buffer, 2.5 μ l 25 mM MgCl₂, 2 μ l dNTP, 0.125 μ l Taq DNA polymerase, 0.625 μ l 10 μ M forward primer, 0.625 μ l 10 μ M reverse primer, 2.5 μ l 0.1 M TMAcI, 2 μ l dimethyl sulfoxide (DMSO), 2 μ l template, and 10 μ l water. In some cases, the amount of primer or template was doubled (replacing some of the water). Primers P17 and 26S-82R (Popp & Oxelman, 2001) were used for amplification. Sequencing reactions were realized using the DYEnamic ET terminator Cycle Sequencing kit (Amersham Biosciences, Buckinghamshire, England) following the protocol of the manufacturer (DMSO was added in the same concentration as in the PCR mix) and run on a MegaBACE 1000 DNA Analysis System (Amersham Biosciences). For sequencing, the same primers were used as in the PCR amplification.

For the ITS study, 50 new ITS sequences were produced, and five additional sequences were downloaded from GenBank and included in the data matrix. Taxon names, authors, vouchers, and GenBank accession numbers are presented in Table 1.

Manual alignment and gapcoding of the ITS sequences were performed with the following criteria: (1) an effort was made to see if gaps/insertions could be interpreted as caused by repeats or inversions, and if so, sequences were aligned to fit these possible events; (2) gaps (i.e., inferred insertion/deletion events) were introduced into the sequences to keep the number of substitutions in an aligned region to a minimum; (3) insertions/deletions and substitutions were considered equally probable events; and (4) gaps/insertions of equal length shared by two or more taxa were inferred to be homologous and binary coded. Gaps of more than one position in length introduced due to multiplication of single nucleotides, e.g., poly-A, were not coded. Regions where alignment could not be unambiguously interpreted were removed from the analysis. After alignment, two ITS matrices were produced, one including gap codings and the other without them. Two parsimony analyses, conducted with PAUP* version 4.0b10 (Swofford, 2000), were performed for each matrix. The first ITS analysis was a heuristic search (random addition sequence with 1000 replicates, tree bisection-reconnection [TBR] branch swapping, and MULTREES option in effect), and the second analysis was a jackknife search (faststep search option, 10,000 replicates, and Jac resample emulation).

For the combined analyses, the data matrix from the ITS study was combined with the entire matrices from the *trnL-F* study of Rova et al. (2002) and from an *rps16* analysis (Rova, unpublished), keeping the indel codings from each matrix. Previous analyses of each separate data set resulted in similar trees, which implied that the data sets were congruent. Taxa not included in the combined analyses were then deleted using the command DELETE in the PAUP block. The resulting set of sequences comprised 20 ingroup taxa. This set included all taxa where all three sequences were available and all *Rondeletia* species where at least ITS and *rps16* sequences were available. *Chiococca alba* was used as outgroup, because, previously, it had been clearly shown not to be part of the ingroup (Rova et al., 2002). The data were analyzed by a heuristic search (random addition sequence with 1000 replicates, TBR branch swapping, and MULTREES option in effect).

RESULTS

More than 50 DNA extractions were obtained from *Rondeletia* representatives, but only 27 of these (representing 23 species) were amplified by PCR and yielded sequences. Extractions that did not produce usable sequences were mostly made from herbarium material more than 50 years old. Material collected in silica gel almost always worked for PCR

and resulted in high-quality sequences. It was not possible to obtain sequences from section *Lindenianae* M. Fernández Zeq., although extractions were attempted from two different specimens. It was also not possible to obtain PCR products from *Roigella correifolia* (Griseb.) Borhidi & M. Fernández Zeq., which *trnL-F* data showed to be closely related to *Rondeletia* s. str. (Rova et al., 2002). For four sections (*Rondeletia* sect. *Odoratae* Standl., section *Pedicellares* Standl., section *Rigidae* M. Fernández Zeq., and section *Chamaebuxifoliae*), it was only possible to sequence one species from each section. We were unfortunately not able to sequence the type species of *Rondeletia*, *R. americana* L. This species seems to be very rarely collected, and extractions made from the herbarium material that we found in the Swedish Museum of Natural History Herbarium did not amplify despite several attempts. We were not able to establish contact with anyone who could assist us with recently collected material from St. Vincent, where the species is endemic, and it was not possible to do such fieldwork ourselves. Ten species that yielded sequences were not listed under any section in the work of Fernández Zequeira, but four of them could be assigned to sections based on the key provided in her paper (Fernández Zequeira, 1994): *R. inermis* (Spreng.) Krug & Urb. and *R. pilosa* Sw. belonging to section *Leoninae*, and *R. hameliifolia* Dwyer & M. V. Hayden and *R. purdiei* Hook. f. belonging to section *Calophyllae* M. Fernández Zeq. Sectional affinities are indicated in Figure 1.

The first ITS matrix, without indel coding, included 699 characters, of which 174 were parsimony informative. The second ITS matrix, where indels were coded, included 723 characters, of which 198 were parsimony informative. The combined ITS, *rps16*, and *trnL-F* matrix included 2751 characters, 1451 of which were parsimony informative.

The strict consensus tree obtained from the ITS analyses is presented in Figure 1. Heuristic searches of both data sets each resulted in 48 most parsimonious trees. Tree lengths were 768 (consistency index [CI] = 0.56, retention index [RI] = 0.76) in the heuristic search of the data set without indel coding and 805 (CI = 0.65, RI = 0.77) in the heuristic search where indels were coded. Strict consensus trees were identical for both data sets. Jackknife support was not found for all clades in the strict consensus trees from the heuristic searches, and jackknife support values for a clade could vary up to more than 10 units between the two data sets. Tree topologies differed only marginally between the two jackknife searches. The jackknife search without indel codings found one clade that was not found in the other jackknife search (or in the heuristic

searches), and the jackknife search with indel codings resulted in two clades not found in the jackknife search without indels coded (Fig. 1). Support for these clades was low in all cases.

The analysis of the combined matrix resulted in 12 equally parsimonious trees (length 2046, CI = 0.91, RI = 0.97). A strict consensus of these trees is shown in Figure 2, and branches from the consensus tree that also occur in the ITS analysis are marked in bold in Figure 1.

DISCUSSION

SECTIONAL CLASSIFICATION OF *RONDELETIA*

The main aim of our study was to test Fernández Zequeira's (1994) classification with 10 sections of *Rondeletia* using molecular phylogenetic analyses. This goal was hard to reach satisfactorily; despite an extensive search, it was difficult to find herbarium or silica gel-dried material that would work for PCR and sequencing. For five of the sections, only one representative of each could be sequenced. Furthermore, ITS data are obviously not variable enough to provide resolution among sections *Hypoleucae* and *Nipenses*. Nevertheless, we obtained several interesting results with regard to the circumscription of *Rondeletia* and some of Fernández Zequeira's sections.

There is strong support for the *Rondeletia* s. str. clade (Fig. 1, clade E). This clade consists of predominantly Antillean species. The only exceptions to this distribution are *R. hameliifolia* from Central America (Panama) and *R. purdiei* from South America (Ecuador). Neither *R. hameliifolia* nor *R. purdiei* were included in Fernández Zequeira's (1994) treatment, but according to her identification key, both species would belong to section *Calophyllae*. In our study, the two species form a clade with strong support. A third representative of this section is *R. alaternoides* A. Rich. from Cuba, which is found in clade F (Fig. 1). Thus, ITS sequence data do not support a monophyletic section *Calophyllae*.

Rondeletia deamii (Donn. Sm.) Standl. is found just outside the *Rondeletia* s. str. clade. The generic position of this Central American species has recently been under debate. Lorence (1999) supported its position in *Rondeletia*, but Borhidi (2001a) positioned it in *Arachnothryx*. Our ITS sequence data suggest that this species should be treated as a *Rondeletia*, although support for this hypothesis is less than 50.

Rondeletia inermis and *R. pilosa* Sw. were not included in Fernández Zequeira's (1994) treatment of Cuban *Rondeletia*, as these species occur in Puerto Rico and the U.S. Virgin Islands, respectively. However, according to her key to sections, they would

both belong to *Rondeletia* sect. *Leoninae*. In our analysis, they form a clade with strong support. *Rondeletia* sect. *Leoninae* would thus be the only one of Fernández Zequeira's sections that is supported by our ITS sequence data.

In all analyses, there is moderate support for a clade with *Rondeletia alaternoides*, *R. odorata* Jacq., and *R. pachyphylla* Krug & Urb. (Fig. 1, clade F), which represent sections *Calophyllae*, *Odoratae*, and *Pedicellares*, respectively. Following the diagnostic table of sections in Fernández Zequeira (1994), we were unable to find any morphological characters that support this group.

Rondeletia intermixta Britton and *R. ochracea* Urb. form a clade with strong support. While *R. intermixta* belongs to section *Rondeletia* M. Fernández Zeq., *R. ochracea* has not been previously classified to any section. It is thus possible to argue that *R. ochracea* should also belong to section *Rondeletia*. The only other known representative of section *Rondeletia* included in our analysis, *R. portoricensis* Krug & Urb., is placed in an unresolved relationship to the *R. intermixta*-*R. ochracea* clade, although jackknife support for this is below 50.

Our study does not show any support for a separation of sections *Hypoleucae* and *Nipenses* in *Rondeletia*. All sequenced representatives of these sections, except *R. berteriana* DC., are found in a strongly supported but unresolved clade (Fig. 1, clade H). No morphological character combination seems to be unique for these two sections as one group, according to the character list in Fernández Zequeira (1994). *Rondeletia berteriana* differs from the other sequenced species of section *Hypoleucae* (and section *Nipenses*) in being from Hispaniola. This species is found as sister to clade H but with very low support (Fig. 1).

Rondeletia chamaebuxifolia Griseb., the only sequenced representative of section *Chamaebuxifoliae*, is found closely related to the species from sections *Hypoleucae* and *Nipenses*. Following the diagnostic characters provided in Fernández Zequeira (1994) for sections *Chamaebuxifoliae*, *Hypoleucae*, and *Nipenses*, this clade (Fig. 1, clade G) could be distinguished from other sections by having 1- to 3-flowered inflorescences and retrorse-pilose flowers.

STEVENSIA

The second aim of our study was to investigate the relationships between *Stevensia* and *Rondeletia*. *Stevensia* is here for the first time included in a molecular phylogenetic study. According to ITS data, there is strong support for an inclusion of at least *S. minutifolia* Alain in *Rondeletia* s. str. The genus

Table 1. Table of taxa included in the study, including ITS and *rps16* voucher information for sequences originally presented in this paper, as well as GenBank accession numbers for all sequences used. If only one voucher is mentioned, the same voucher is used for both ITS and *rps16* sequencing unless the other sequence is cited from a previous publication.

Taxon	Voucher data	GenBank accession number		
		ITS	<i>rps16</i>	<i>trnL-F</i>
<i>Acrosynanthus revolutus</i> Urb.	Cuba, P. G. Delprete et al. 8818 (UPS)	AY730288		
<i>Arachnothryx buddleioides</i> (Benth.) Planch.	Panama, J. Rova & Sundbaum 2411 (S)	AY730299		
<i>Arachnothryx chimboracensis</i> (Standl.) Steyerem.	Ecuador, P. G. Delprete & A. Verduga 6398 (NY)	AY730292		
<i>Arachnothryx leucophylla</i> (Kunth) Planch.	Cuba, J. Rova et al. 2287 (GB)	AY730296	AF242910	AF152718 ^o
<i>Arachnothryx</i> sp. indet.	Ecuador, G. Harling 27108 (NY)	AY730298		
<i>Blepharidium guatemalense</i> Standl.	Guatemala, Gustafsson et al. 212 (GB)	AY730287	AF242916	AF152735 ^o
<i>Catesbaea fuerstesii</i> Urb.		AY205364 ¹		
<i>Chiococca alba</i> (L.) Hitchc.		AY205367 ¹	AF004034 ⁴	AF102400 ⁷
<i>Cuatrecasiodendron spectabile</i> Steyerem.	Colombia, J. Rova et al. 2093 (S)	AY730297	AF242934	
<i>Gonzalagunia affinis</i> Standl. ex Steyerem.	Ecuador, Bremer et al. 3350 (UPS)	AY730295		
<i>Guettarda scabra</i> (L.) Lam.	Cuba, Rova et al. 2260 (GB)	AF323061 ²	AF242963	
<i>Guettarda uruguensis</i> Cham. & Schlttdl.	cultivated at Fairchild Tropical Garden, FTC x 5-127, Gillis 9575 (FTG)	AY730294		
<i>Hodgkinsonia ovatiflora</i> F. Muell.	Australia, Puttock 8602667 (UNSW)	AY730293		
<i>Luculia grandifolia</i> Ghose		AJ346896 ³		
<i>Mazaea phialanthoides</i> (Griseb.) Krug & Urb.	Cuba, J. Rova et al. 2264 (GB)	AY730302	AF242980	AF152749 ^o
<i>Mazaea shaferi</i> (Standl.) Delprete	ITS: Cuba, T. McDowell 4826-1993 (DUKE); <i>rps16</i> : Cuba, Rova et al. 2224 (GB)	AY730304	AF242911	AF152750 ^o
<i>Phyllomelia coronata</i> Griseb.	Cuba, P. G. Delprete et al. 8913 (UPS)	AY730303		
<i>Rachicallis americana</i> (Jacq.) Hitchc.	cultivated at Fairchild Tropical Garden, FTC 64-266, Fanning KF81 (FTG)	AY730301	AF004073 ⁴	AF152747 ^o
<i>Rogiera amoena</i> Planch.	ITS: Mexico, Mexia 8982 (GB); <i>rps16</i> : Guatemala, Hawkes et al. 1962 (S)	AY730286	AF243000	AF102474 ⁷
<i>Rogiera cordata</i> (Benth.) Planch.	ITS: Guatemala, Gustafsson & Fredriksson 126 (GB); <i>rps16</i> : cultivated at Royal Botanical Garden, Kew, Chase 2267 (K)	AY730285	AF242999	AF152715 ^o
<i>Rogiera cordata</i> (Benth.) Planch.	Guatemala, J. J. Castillo & R. Luarca 2005 (NY)	AY730284		
<i>Rovaeanthus strigosus</i> (Benth.) Borhidi	cultivated at PTBG, D. Lorence 8920 (PTBG)	AY730291		
<i>Rovaeanthus suffrutescens</i> (Brandegee) Borhidi	cultivated at the Bergius Botanical Garden, Stockholm, Bremer 2712 (S)	AY730290	AF243003	AF152738 ^o
<i>Rondeletia alaternoides</i> A. Rich. subsp. <i>alaternoides</i>	Cuba, P. G. Delprete et al. 8725 (UPS)	AY730306		
<i>Rondeletia alaternoides</i> subsp. <i>brachyloba</i> M. Fernández Zeq. & Borhidi	Cuba, J. Rova et al. 2228 (GB)	AY730310	AF243006	AF152740 ^o

Table 1. Continued.

Taxon	Voucher data	GenBank accession number		
		ITS	<i>rps16</i>	<i>trnL-F</i>
<i>Rondeletia apiculata</i> Urb.	Cuba, J. Rova et al. 2243 (GB)	AY730312	AF243007	
<i>Rondeletia barahonensis</i> Urb.	Dominican Republic, P. G. Delprete et al. 7534 (UPS)	AY730321		
<i>Rondeletia berteriana</i> DC.	Dominican Republic, P. G. Delprete et al. 7567 (UPS)	AY730322		
<i>Rondeletia chamaebuxifolia</i> Griseb.	Cuba, Machado et al. s.n. 1995-03-16 (S)	AY730327		
<i>Rondeletia cincta</i> Griseb.	Jamaica, P. G. Delprete et al. 7503 (UPS)	AY730323		
<i>Rondeletia</i> sp.	Jamaica, P. G. Delprete et al. 7479 (UPS)	AY730324		
<i>Rondeletia deamii</i> (Donn. Sm.) Standl.	Guatemala, J. J. Castillo 1560 (NY)	AY730305	AJ786765 ^s	
<i>Rondeletia hameliifolia</i> Dwyer & M. V. Hayden	Panama, J. H. Kirkbride & S. M. V. Hayden 164 (NY)	AY730326		
<i>Rondeletia inermis</i> (Spreng.) Krug & Urb.	ITS: Cultivated at PTBG, D. Lorence 8796 (PTBG); <i>rps16</i> : Puerto Rico, Acevedo-Rodriguez et al. 7691 (NY)	AY730315	AF243012	AF152745 ^o
<i>Rondeletia intermixta</i> Britton subsp. <i>intermixta</i>	Cuba, J. Rova et al. 2245 (GB)	AY730311	AF004077 ⁴	AF152742 ^o
<i>Rondeletia lomensis</i> Urb.	Cuba, J. Rova et al. 2216 (GB)	AY730313		
<i>Rondeletia miraflorensis</i> M. Fernández Zeq. & Borhidi	Cuba, J. Rova et al. 2217 (GB)	AY730314	AF243009	
<i>Rondeletia nipensis</i> Urb.	Cuba, P. G. Delprete et al. 8651 (UPS)	AY730330		
<i>Rondeletia nipensis</i> subsp. <i>moaensis</i>	Cuba, P. G. Delprete et al. 8770 (UPS)	AY730325		
<i>Rondeletia ochracea</i> Urb.	Dominican Republic, W. C. Holmes et al. 6618 (NY)	AY730316		
<i>Rondeletia odorata</i> Jacq.	cultivated at the Bergius Botanical Garden, Stockholm, Bremer & Andreasen 3504 (UPS)	AY730307	AF243010	AF152741 ^o
<i>Rondeletia pachyphylla</i> Krug & Urb. subsp. <i>myrtilloides</i>	Cuba, J. Rova et al. 2232 (GB)	AY730331	AF243011	
<i>Rondeletia pachyphylla</i> Krug & Urb. subsp. <i>pachyphylla</i>	Cuba, P. G. Delprete et al. 8674 (UPS)	AY730317		
<i>Rondeletia pilosa</i> Sw.	U.S. Virgin Islands, P. Acevedo-Rodriguez 2836 (NY)	AY730332	AF243014	AF152744 ^o
<i>Rondeletia pitreana</i> Urb. & Ekman	Hispaniola, Liogier 13966 (NY)	AY730289		
<i>Rondeletia plicatula</i> Urb.	Cuba, P. G. Delprete et al. 8716 (UPS)	AY730318		
<i>Rondeletia portoricensis</i> Krug & Urb.	Puerto Rico, C. M. Taylor 11687 (MO)	AY730333	AF243015	AF152743
<i>Rondeletia purdiei</i> Hook. f.	Ecuador, Corbisier-Baland 1905 (UPS)	AY730328		
<i>Rondeletia stipularis</i> (L.) Druce	Jamaica, P. G. Delprete et al. 7472 (UPS)	AY730319		
<i>Rondeletia subcanescens</i> M. Fernández Zeq. & Borhidi	Cuba, P. G. Delprete et al. 8761 (UPS)	AY730320		
<i>Rondeletia subcanescens</i> M. Fernández Zeq. & Borhidi	Cuba, P. G. Delprete et al. 8833 (UPS)	AY730329		
<i>Stevensia minutifolia</i> Alain	Dominican Republic, P. G. Delprete et al. 7540 (UPS)	AY730308		
<i>Stevensia minutifolia</i> Alain	Dominican Republic, A. Liogier 13663 (NY)	AY730309		
<i>Suberanthus brachycarpus</i> (Griseb.) Borhidi & M. Fernández Zeq.	Cuba, T. McDowell 4824-1993 (DUKE)	AY730300		
<i>Timonius nitidus</i> Fern.-Vill.		AF323063 ²		

The cited literature for published sequences includes: ¹McDowell et al., 2003; ²Moynihan & Watson, 2001; ³Razafimandimbison & Bremer, 2002; ⁴Andersson & Rova, 1999; ^oRova et al., 2002; ^sStruwe et al., 1998. Sequences were also taken from ⁵S. Stranczinger, F. Jakab, J. L. Szentpeteri & A. Borhidi, unpublished.

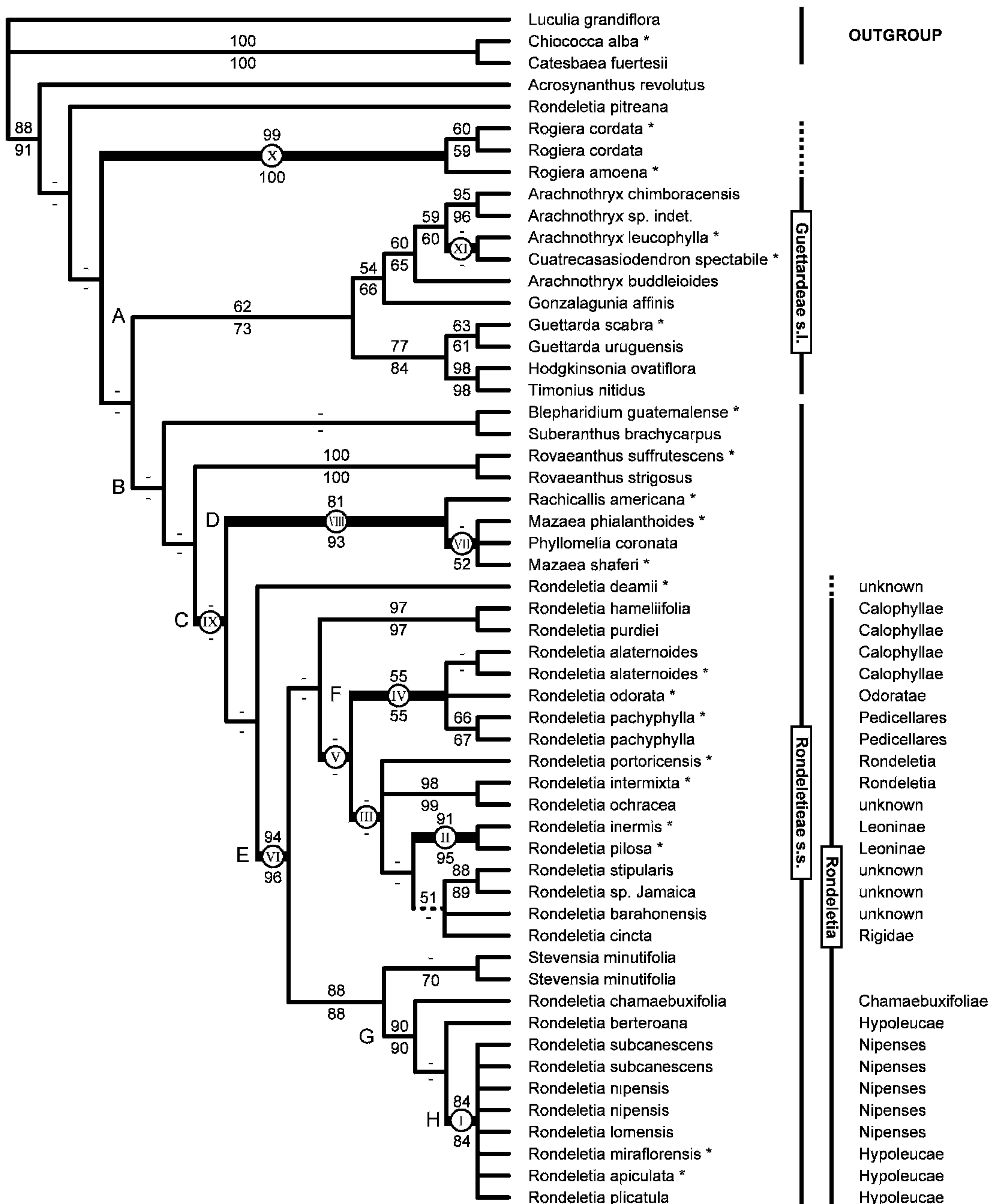

Figure 1. Tree compiled from the strict consensus trees from the two heuristic searches, without and with indels coded, respectively. The one dotted branch was not found in the heuristic searches, only in the jackknife search without indels coded. Numbers indicate jackknife support: numbers above branches are support values without indels coded, and numbers below branches are support values with indels coded. Jackknife support of 50 and lower is indicated by dashes (–). Letters A–H indicate the clades discussed in the text: —A. Clade comprising representatives of the tribe Guettardeae. —B. Clade corresponding to *Rondeletieae* sensu Rova et al. (2002). —C. Clade comparable to the one in which *Acrosynanthus* was found in Rova et al. (2002). —D. Clade comprising *Mazaea*, *Phyllomelia*, and *Rachicallis*. —E. The *Rondeletia* s. str. clade. —F. Clade including representatives of sections *Odoratae*, *Pedicellares*, and the paraphyletic section *Calophyllae*. —G. Clade distinguished by having 1- to 3-flowered inflorescences and retrorse-pilose flowers (corresponding to sections *Chamaebuxifoliae*, *Hypoleucaae*, and *Nipenses*). —H. Clade comprising Cuban representatives of sections *Hypoleucaae* and *Nipenses*. Taxa marked by an asterisk (*) are included in the combined ITS, *rps16*, and *trnL-F* analysis presented in Figure 2. The circled Roman numerals I–XI on bold branches refer to clades in the combined ITS, *rps16*, and *trnL-F* analysis (Fig. 2).

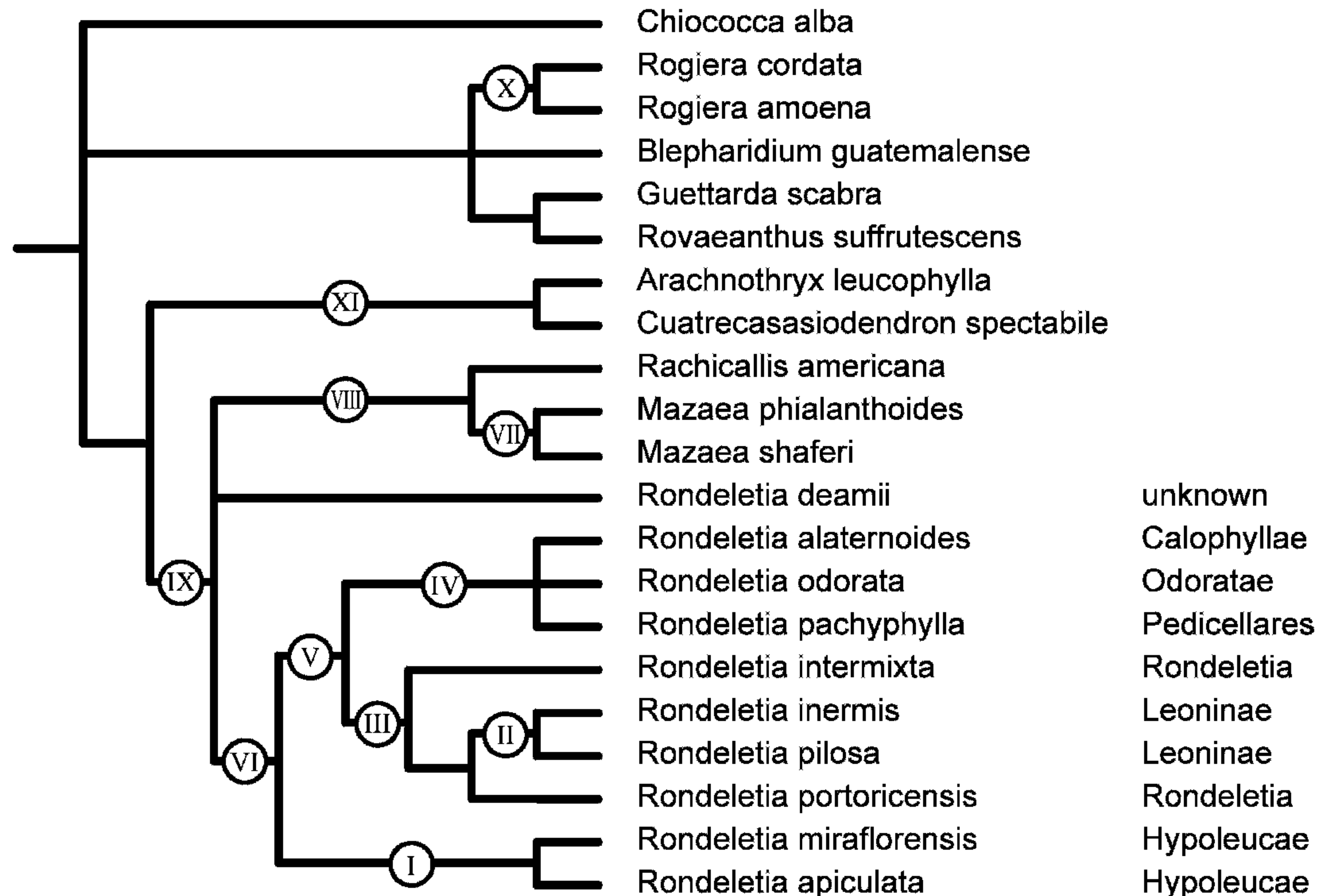

Figure 2. Strict consensus tree of the 12 equally parsimonious trees from the analysis of the combined ITS, *rps16*, and *trnL-F* data matrix. *Guettarda scabra*, *Cuatrecasasi dendron spectabile*, *Rondeletia deamii*, *R. pachyphylla*, *R. miraflorensis*, and *R. apiculata* were only represented by ITS and *rps16* data in the data set. The circled Roman numerals I–XI on branches refer to clades in the tree in Figure 1. Sectional assignment of *Rondeletia* species, according to Fernández Zequeira (1994), is listed in the rightmost column. *Rondeletia inermis* and *R. pilosa* were not listed in Fernández Zequeira (1994), but have been assigned to section based on her key. *Rondeletia deamii* is not assigned to a section (cf. unknown among the sectional assignments).

Stevensia comprises 11 species endemic to Hispaniola. It is recognized by triangular stipules connected to a sheath, solitary and axillary flowers, two to three calyx lobes, five to seven stamens attached in the corolla throat, glabrous style, and ovoid to oblong seeds (Borhidi, 2001b). However, several of these character states are also found within *Rondeletia* s. str., according to Fernández Zequeira (1994). We therefore suggest that *Stevensia* should be included within *Rondeletia* s. str., pending future studies with an extended sampling.

GUETTARDEAE AND RONDELETIEAE

Our third aim was to compare a nuclear ITS phylogeny of the Rondeletieae with the results from a previous *trnL-F* chloroplast DNA (cpDNA) study

(Rova et al., 2002). The fourth aim was to see if ITS sequence data would place *Hodgkinsonia* in Guettardeae or elsewhere.

Acrosynanthus revolutus Urb. and *Rondeletia pitreana* Urb. & Ekman (not classified to section) appear as early diversified lineages in the cladogram. One possible explanation for the position of *R. pitreana* could be that we were not able to read the sequence in its entirety. Because of this, it is about 40 bases shorter than the other *Rondeletia* sequences. Another possibility is that *R. pitreana* does not belong to *Rondeletia*. In any case, further studies are needed to solve the position of *R. pitreana*. The position of *Acrosynanthus* Urb. in the present analysis differs markedly from the results of the *trnL-F* study from Rova et al. (2002), where *Acrosynanthus* was found in a position equivalent to basal in clade C (Fig. 1). A

←

Sectional assignment of *Rondeletia* species, according to Fernández Zequeira (1994), is listed in the rightmost column. *Rondeletia hameliifolia*, *R. purdiei*, *R. inermis*, and *R. pilosa* were not listed by Fernández Zequeira, but have been assigned to section based on her key (1994: 106).

possible explanation would be that *Acrosynanthus* is not monophyletic: *A. latifolius* Standl. was included in the *trnL-F* study, but *A. revolutus* was sequenced in the ITS analysis. However, the possible paraphyly of *Acrosynanthus* must be left to another study when more material of this genus is available.

We found that the well-supported Guettardeae s.l. and Rondeletieae s. str. clades in the *trnL-F* study from Rova et al. (2002) have only weak support from ITS sequence data.

With regard to the tribe Guettardeae, there is moderate support for a clade including *Arachnothryx*, *Gonzalagunia*, *Cuatrecasiodendron*, *Guettarda*, *Hodgkinsonia*, and *Timonius* (Fig. 1, clade A). According to our results, *Cuatrecasiodendron* should be synonymized with *Arachnothryx*, and this is also morphologically supported (see taxonomic treatment below). While *trnL-F* data (Rova et al., 2002) showed *Rogiera amoena* Planch. and *R. cordata* (Benth.) Planch. as members of the Guettardeae, the inclusion of *Rogiera* s. str. in the Guettardeae clade is not supported by ITS data alone. In the combined analysis (Fig. 2), *Rogiera* is found within Guettardeae, while *Arachnothryx* is found to be more closely related to Rondeletieae.

In a recent molecular phylogenetic study, Achille et al. (2006) supported the monophyly of the Guettardeae as recognized here, although they showed that *Guettarda*, *Antirhea* Comm. ex Juss., and *Stenostomum* C. F. Gaertn. are polyphyletic. However, more genera and more species need to be included in the study in order to test the monophyly and delimitation of this tribe.

Although Rondeletieae sensu Rova et al. (2002) is recognized by ITS data in the consensus trees (Fig. 1, clade B), there is no jackknife support for this clade.

In both heuristic ITS searches, the genera *Blepharidium* Standl. and *Suberanthus* were found basal in the Rondeletieae s. str. clade, but again, there is no jackknife support for this. However, this position corresponds to the results from the *trnL-F* study of Rova et al. (2002).

The ITS data place *Rovaeanthus strigosus* (Benth.) Borhidi in the Rondeletieae, as sister taxon to *R. suffrutescens* (Brandegge) Borhidi. Just as in the *trnL-F* study (Rova et al., 2002), the ITS data indicate that *R. suffrutescens* belong to the Rondeletieae s. str. (although this is contradicted in the combined analysis where *R. suffrutescens* is found as sister to *Guettarda*). In any case, *R. suffrutescens* always appears in a separate position from *Rogiera*, and our study thus supports the transfer of these species from *Rogiera* into a new genus as proposed by Borhidi et al. (2004).

There is strong support for a close relationship between *Rachicallis* DC., *Mazaea* Krug & Urb., and

Phyllomelia Griseb. (D in Fig. 1). *Rachicallis* and *Phyllomelia* are monotypic genera, and *Mazaea* only comprises two species. Based on ITS data, one could argue that all three genera should be merged together. However, both *Mazaea* and *Phyllomelia* are easily distinguished by the peculiar fruit (pseudosamara, sensu Delprete, 1999b) and calyx morphology (Delprete, 1999b), and for this reason we prefer to regard them as separate genera.

HODGKINSONIA

The fourth aim was to see if ITS sequence data would place *Hodgkinsonia* in Guettardeae or elsewhere. Our study undoubtedly places *Hodgkinsonia* close to *Timonius*, which means within Guettardeae. This position is in accordance with the view of Mueller (1861) in the original description and Bremer (1992), but contradicts the supposition of Delprete (1996), who tentatively included the genus in tribe Chiococceae in agreement with Robbrecht (1988).

CONCLUSION

The ITS sequence data support only one of Fernández Zequeira's (1994) *Rondeletia* sections as monophyletic: section *Leoninae*. *Rondeletia* sections *Calophyllae* and *Rondeletia* are paraphyletic according to our analysis. However, one should bear in mind that we were not able to sequence more than one species from several sections. When we compare our ITS phylogeny with the character lists in Fernández Zequeira's treatment of *Rondeletia*, we were unable to find morphological characters that correspond with our phylogenies. The sections described by Fernández Zequeira are often defined by various combinations of overlapping character states, which makes comparisons difficult. The only exception is a clade including representatives from *Rondeletia* sections *Chamaebuxifoliae*, *Hypoleucae*, and *Nipenses*, which could be distinguished by having 1- to 3-flowered inflorescences and retrorse-pilose flowers. This clade could potentially be recognized as one section.

Rondeletia s. str. (i.e., excluding *Arachnothryx*, *Javorkaea*, *Rogiera*, *Roigella*, *Rovaeanthus*, and *Suberanthus*) has strong support, although some species need to be further investigated for their generic affinity (e.g., *R. pitreana* and *R. deamii*).

An important result from our study is that *Stevensia minutifolia* is included within *Rondeletia* s. str. A reevaluation of the morphological characters in *Rondeletia* (including *Stevensia*) based on the results from ITS and other sequence data is certainly needed. The present analysis clearly suggests that *Stevensia* should be recognized at most as a section of *Rondeletia*.

There is strong support for a division of the *Rondeletieae*–*Guettardeae* complex into the tribes *Rondeletieae* s. str. and *Guettardeae* s.l. from *trnL-F* data (Rova et al., 2002), but only weak support from ITS data. While part of the *Guettardeae* has moderate support, support for *Rondeletieae* in the sense of Rova et al. (2002) is weak in the ITS study, although the *Rondeletieae* s. str. clade is found in the strict consensus trees of all of our analyses, both including and excluding indel codings. It was not possible to compile a sufficiently large data set in order to test the delimitations of *Guettardeae* and *Rondeletieae* using a combined ITS, *rps16*, and *trnL-F* sequence data matrix; however, we consider that the phylogenies available up to this point (Rova, 1999; Rova et al., 2002; Delprete & Cortés-B., 2004; the present study) provide sufficient support for a re-delimitation of the tribe *Rondeletieae*.

Based on the results from ITS sequence data, we also reconsider Delprete's (1996) tentative inclusion (based on morphology) of *Hodgkinsonia* in the *Chiococceae*, since the present ITS sequence data support Bremer's (1992) conclusion (also based on morphological data) that *Hodgkinsonia* is part of the tribe *Guettardeae*.

TAXONOMIC TREATMENT

Based on the results from the present and other recent studies (Delprete, 1999b; Rova, 1999; Rova et al., 2002; Delprete & Cortés-B., 2004; Borhidi et al., 2004), we propose the following taxonomic descriptions and rearrangements.

Tribe ***Rondeletieae*** (DC.) Miq., *Flora Nederl. Indië* 2: 130, 156. 1856. *Rondeletiinae* DC., *Prodr.* 4: 342, 401. 1830, as subtribe "Rondeletieae," tribe *Hedyotideae*. *Rondeletieae* DC. ex Rchb., *Der Deutsche Botaniker* 1: 77. 1841, stat. non indic. TYPE: *Rondeletia* L.

Shrubs or trees; wood whitish or yellowish; raphides absent; axillary thorns absent. Stipules free or connate at base, mostly entire, rarely bifid, mostly interpetiolar, frequently with colleters on the adaxial side secreting resinous compounds, persistent to readily caducous; leaves opposite or verticillate, decussate, petiolate to sessile, blades chartaceous to thick-coriaceous; domatia variably present or absent. Inflorescences terminal or axillary, cymose, paniculate or thyrsoid, multiflorous or pauciflorous, or uniflorous. Flowers hermaphroditic, mostly actinomorphic, (3- to)4- to 6-merous; calyx persistent or caducous; lobes often minute, sometimes foliose; calyophylls commonly absent or pterophyllous (green to greenish white), with all calyx lobes expanding into

a rotate pterophyll after anthesis and present in all flowers in *Phyllomelia*; corolla hypocrateriform or narrowly infundibuliform, orifice with annular thickening, white, cream-white, red, green, or yellow, membranous to fleshy; aestivation valvate, contorted, or imbricate; stamens mostly as many as corolla lobes, inserted near the base or at the medial zone or near the orifice of corolla tube; anthers included or exerted, oblong to narrowly elliptic to button-shaped, 2-locular, opening by longitudinal slits, dorsifixed near the base or around the middle, introrse; pollen released as monads, colpate or colporate, exine reticulate or foveolate (not echinate); style branches present, with stigmatic surface smooth to verrucate; ovary inferior (half-inferior in *Rachicallis*), bilocular, with a few to many ovules (1 to 2 in *Mazaea*) per locule attached to a central placenta, or exceptionally one ovule per locule basally attached (*Phyllomelia*). Fruits woody capsules, loculicidal or septicidal, or septicidal and loculicidal contemporaneously (*Blepharidium*, *Mazaea*), commonly dehiscent basipetally, or exceptionally pseudosamaras, indehiscent (*Phyllomelia*); placenta central, rarely apically incomplete, or shortly stalked; seeds horizontal, imbricate, peltate, and vertical, minute, 3- to 5-angular or dorsoventrally convex, not winged, wing concentric or bipolar (*Blepharidium*, *Mazaea*), or basally inserted, ellipsoid-ovoid and fleshy (*Phyllomelia*).

Genera included: *Acrosynanthus*, *Acunaeanthus* Borhidi, Komlodi & Moncada, *Blepharidium*, *Glionnetia* Tirveng., *Habroneuron* Standl., *Mazaea*, *Phyllomelia*, *Rachicallis*, *Rogiera*, *Roigella*, *Rondeletia*, *Rovaeanthus*, *Spathichlamys* R. Parker, *Stevensia*, *Suberanthus*.

The description and delimitation of the *Rondeletieae* here proposed are based on the results of the present study in combination with those of Rova (1999) and Rova et al. (2002). The description is basically a reduction of that proposed by Delprete (1999a), based on his wide circumscription of the tribe to include the *Condamineae* and the *Sipaneeae*, which was produced primarily for the floristic treatment and not based on a comprehensive phylogenetic analysis.

Rova (1999) and Rova et al. (2002) demonstrated that the *Condamineae* (except the subtribe *Portlandiinae*, which belongs to the *Chiococceae* s.l.) should be transferred to the subfamily *Ixoroideae*, in a complex also including the *Calycophylleae* and the *Hippotideae* (more studies are needed to re-delimit these groups; Kainulainen & Bremer, unpublished). Delprete and Cortés-B. (2004) and Rova et al. (2002) also demonstrated that the *Sipaneeae* belongs to the subfamily *Ixoroideae* and is a monophyletic group that was positioned in the same clade as the tribes

Henriquezieae and Posoquerieae in their phylogenetic analysis (Delprete et al., 2004).

The monotypic genus *Rachicallis*, endemic to the Caribbean Basin, is added (not included in the tribe by Delprete, 1999a) to the present delimitation of the Rondeletieae, which was placed close to this tribe in Bremer et al. (1995) and shown to belong to Rondeletieae by Rova et al. (2002) and in the present study.

As a result of this study, *Stevensia* is perhaps best treated as synonymous with *Rondeletia*, because in the phylogenies obtained it is positioned within the *Rondeletia*. However, as only one species of *Stevensia* (*S. minutifolia*) was included in the analysis, we refrain from proposing the necessary new combinations.

TAXA TRANSFERRED TO THE TRIBE GUETTARDEAE

Steyermark (1964) positioned *Cuatrecasiodendron* in the Rondeletieae because of its foliaceous calyx lobes, capsular fruits, horizontal seeds, ovary with many ovules in each locule, and corolla with imbricate lobes. At the same time, he treated it as closely related to *Rondeletia* because of the corolla lobes being subzygomorphic, as the most interior lobe is more pubescent internally than the external ones, and glabrous or almost glabrous externally, while the others are pubescent externally. This genus was maintained in the Rondeletieae by Delprete (1999a) because of the same characters as used by Steyermark. However, in the phylogenies produced in the present study, *Cuatrecasiodendron* was found within the *Arachnothryx* clade of the tribe Guettardeae, and the two taxa are treated here as synonymous.

In addition, a detailed analysis of the two species of *Cuatrecasiodendron* described by Steyermark was undertaken. Steyermark (1964) distinguished *C. spectabile* Steyerm. from the type species because of its leaf blades hirsute below (vs. adpressed-pilose to arachnoid-pubescent below), shorter petioles, shorter stipules, corollas 17–20 mm long (vs. ca. 28 mm long, with longer pubescence), and longer and more secundiflorous inflorescence branches among other characters. A comparison of the type specimens with recent collections revealed that the characters used by Steyermark to separate the two taxa fall into a morphologic (and geographic) gradient.

The types of both taxa of *Cuatrecasiodendron* were collected in the Valle del Cauca Department (Colombia); however, *C. spectabile* is from a low elevation of the coastal region, while *C. colombianum* Standl. & Steyerm. is from higher elevations of the Central Cordillera, and recent collections showed intermediate characteristics. Therefore, the two spe-

cies are treated here as synonymous to one another, and only one new combination in *Arachnothryx* is necessary.

Arachnothryx Planch., Fl. Serres Jard. Eur. 5: 442. 1849. TYPE: *Arachnothryx leucophylla* (Kunth) Planch. (= *Rondeletia leucophylla* Kunth).

Cuatrecasiodendron Standl. & Steyerm., Acta Biol. Venez. 4: 29. 1964. Syn. nov. TYPE: *Cuatrecasiodendron colombianum* Standl. & Steyerm.

Arachnothryx spectabilis (Steyerm.) Rova, Delprete & B. Bremer, comb. nov. Basionym: *Cuatrecasiodendron spectabile* Steyerm., Acta Biol. Venez. 4: 33. 1964. TYPE: Colombia. Valle del Cauca Department: Costa del Pacifico, Río Cajambre, Barco, 5–80 m, 21–30 Apr. 1944 (fl.), *J. Cuatrecasas 17165* (holotype, US!; isotype, VEN!).

Cuatrecasiodendron colombianum Standl. & Steyerm., Acta Biol. Venez. 4: 30. 1964. Syn. nov. TYPE: Colombia. Valle del Cauca Department: Cordillera Central, Vertiente Occidental, Hoya del Río Achicayá, Quebrada El Retiro, 300 m, 19 Dec. 1942 (fl.), *J. Cuatrecasas 13694* (holotype, F!; isotype, US!).

Additional specimen examined. COLOMBIA. **Depto. Valle del Cauca:** Mun. Buenaventura, rd. Queremal–Anchicayá, Km 35, ca. 03°37'N, 76°53'W, ca. 300 m, 9 Apr. 1994 (fl.), *J. H. E. Rova, L. Andersson, C. Gustafsson & C. Persson 2093* (GB).

Literature Cited

- Achille, F., T. J. Motley, P. P. Lowry II & J. Jérémie. 2006. Polyphyly in *Guettarda* L. (Rubiaceae, Guettardeae) based on nrDNA ITS sequence data. *Ann. Missouri Bot. Gard.* 93: 103–121.
- Andersson, L. & J. H. E. Rova. 1999. The *rps16* intron and the phylogeny of the Rubioideae (Rubiaceae). *Pl. Syst. Evol.* 214: 161–186.
- Borhidi, A. 1982. Studies in Rondeletieae (Rubiaceae). III. The genera *Rogiera* and *Arachnothryx*. *Acta Bot. Acad. Sci. Hung.* 28: 65–71.
- . 1989. Studies on Rondeletieae (Rubiaceae). XI. Critical notes on some Central American species of *Rondeletia* s.l. *Acta Bot. Hung.* 35: 309–312.
- . 1993–1994 [1994]. Studies in Rondeletieae. XII. New combinations of Mexican and Central American taxa. *Acta Bot. Hung.* 38: 139–142.
- . 2001a. Additions and corrections to the “Nomenclator of Mexican and Central American Rubiaceae” of D. H. Lorence. *Acta Bot. Hung.* 43: 37–78.
- . 2001b. Revisión taxonómica del género *Stevensia* Poit. *Acta Bot. Hung.* 43: 287–298.
- & M. Fernández Zequeira. 1981a. Studies in Rondeletieae (Rubiaceae) I. A new genus: *Roigella*. *Acta Bot. Acad. Sci. Hung.* 27: 309–312.
- & ———. 1981b. Studies in Rondeletieae (Rubiaceae). II. A new genus: *Suberanthus*. *Acta Bot. Acad. Sci. Hung.* 27: 313–316.
- & M. Járjai-Komlódi. 1983. Studies in Rondeletieae (Rubiaceae). IV. A new genus: *Javorkaea*. *Acta Bot. Hung.* 29: 13–27.

- , J. Darók, M. Kocsis, Sz. Stranzinger & F. Kaposvári. 2004. El *Rondeletia* complejo en México. *Acta Bot. Hung.* 46: 91–135.
- Bremer, B. 1992. Phylogeny of the Rubiaceae (Chiococceae) based on molecular and morphological data—Useful approaches for classification and comparative ecology. *Ann. Missouri Bot. Gard.* 79: 380–387.
- & M. Thulin. 1998. Collapse of Isertieae, re-establishment of Mussaendeae, and a new genus of Sabiceae (Rubiaceae): Phylogenetic relationships based on *rbcL* data. *Pl. Syst. Evol.* 211: 71–92.
- , K. Andreassen & D. Olsson. 1995. Subfamilial and tribal relationships in the Rubiaceae based on *rbcL* sequence data. *Ann. Missouri Bot. Gard.* 82: 383–397.
- Delprete, P. G. 1996. Evaluation of the tribes Chiococceae, Condamineae, and Catesbaeeae (Rubiaceae) based on morphological characters. *Opera Bot. Belg.* 7: 165–192.
- . 1999a. *Rondeletieae* (Rubiaceae)—Part I. *Fl. Neotrop. Monogr.* 77: 1–226.
- . 1999b. Morphological and taxonomical comparison of the Cuban endemic taxa *Ariadne*, *Mazaea*, *Acunaeanthus*, *Phyllomelia* (Rubiaceae, *Rondeletieae*), and *Eosanthe*, with one new combination. *Brittonia* 51: 217–230.
- & R. Cortés-B. 2004. A phylogenetic study of the tribe Sipaneeae (Rubiaceae, Ixoroideae), using *trnL-F* and ITS sequence data. *Taxon* 53: 347–356.
- , L. B. Smith & R. B. Klein. 2004. [Description of the tribe Posoquerieae] Rubiaceae, Volume 1—Gêneros de A–G: 1. *Alseis* até 19. *Galium*. (com observações ecológicas por R. Klein, A. Reis & O. Iza). Pp. 1–344 in A. Reis (editor), *Flora Ilustrada Catarinense*. Herbário Barbosa Rodrigues, Itajaí, Santa Catarina, Brazil.
- Doyle, J. J. & J. L. Doyle. 1987. A rapid DNA isolation procedure for small quantities of fresh leaf tissue. *Phytochem. Bull.* 19: 11–15.
- Fernández Zequeira, M. 1993–1994 [1994]. Estudio taxonómico del género *Rondeletia* L. s.l. (Rubiaceae) en Cuba. *Acta Bot. Hung.* 38: 47–138.
- Lorence, D. H. 1991. New species and combinations in Mexican and Central American *Rondeletia* (Rubiaceae). *Novon* 1: 135–157.
- . 1999. A Nomenclator of Mexican and Central American Rubiaceae. *Mongr. Syst. Bot. Missouri Bot. Gard.* 73: 1–177.
- McDowell, T., M. Volovsek & P. Manos. 2003. Biogeography of *Exostema* (Rubiaceae) in the Caribbean region in light of molecular phylogenetic analyses. *Syst. Bot.* 28: 431–441.
- Moynihan, J. & L. E. Watson. 2001. Phylogeography, generic allies, and nomenclature of Caribbean endemic genus *Neolaugeria* (Rubiaceae) based on ITS sequences. *Int. J. Pl. Sci.* 162: 393–401.
- Mueller, F. 1861. *Fragmenta Phytographiae Australiae* 2. Joannis Ferres, Melbourne.
- Popp, M. & B. Oxelman. 2001. Inferring the history of the polyploid *Silene aegaea* (Caryophyllaceae) using plastid and homoeologous nuclear DNA sequences. *Molec. Phylogenet. Evol.* 20: 474–481.
- Razafimandimbison, S. & B. Bremer. 2002. Phylogeny and classification of Naucleae s.l. (Rubiaceae) inferred from molecular (ITS, *rbcL*, and *trnT-F*) and morphological data. *Amer. J. Bot.* 89: 1027–1041.
- Robbrecht, E. 1988. Tropical woody Rubiaceae. *Opera Bot. Belg.* 1: 1–272.
- . 1993 [1994]. Supplement to the 1988 classification of the Rubiaceae. Index to genera. Pp. 173–196 in E. Robbrecht (editor), *Advances in Rubiaceae Macrosystematics*. *Opera Bot. Belg.* Vol. 6.
- Rova, J. H. E. 1999. The Condamineae–*Rondeletieae*–Sipaneeae Complex (Rubiaceae). Doctoral Dissertation, Botanical Institute, University of Göteborg, Göteborg, Sweden.
- , P. G. Delprete, L. Andersson & V. A. Albert. 2002. A *trnL-F* cpDNA sequence study of the Condamineae–*Rondeletieae*–Sipaneeae complex with implications on the phylogeny of the Rubiaceae. *Amer. J. Bot.* 89: 145–159.
- Standley, P. C. 1918. *Rondeletia*. *N. Amer. Fl.* 32: 3–86.
- Steyermark, J. A. 1964. Novedades en las Rubiaceas Colombianas de Cuatrecasas. *Acta Biol. Venez.* 4: 1–117.
- . 1967. *Rondeletia* and *Arachnothryx*. Pp. 241–261 in B. Maguire & collaborators (editors), *The Botany of the Guyana Highland*, Part VII. *Mem. New York Bot. Gard.* Vol. 17.
- Struwe, L., M. Thiv, J. W. Kadereit, A.-R. Pepper, T. J. Motley, P. J. White, J. H. E. Rova, K. Potgeiter & V. A. Albert. 1998. *Saccifolium* (Saccifoliaceae), an endemic of Sierra de la Neblina on the Brazilian–Venezuelan border, is related to a temperate-alpine lineage of Gentianaceae. *Harvard Pap. Bot.* 3: 199–214.
- Swofford, D. L. 2002. PAUP*: Phylogenetic Analysis Using Parsimony (*and Other Methods), Version 4. Sinauer Associates, Sunderland, Massachusetts.

PHYLOGENY OF *TRICALYSIA* (RUBIACEAE) AND ITS RELATIONSHIPS WITH ALLIED GENERA BASED ON PLASTID DNA DATA: RESURRECTION OF THE GENUS *EMPOGONA*¹

James Tosh,² Aaron P. Davis,³ Steven Dessen,⁴
Petra De Block,⁴ Suzy Huysmans,² Mike F. Fay,³
Erik Smets,^{2,5} and Elmar Robbrecht⁴

ABSTRACT

Recent studies on the circumscription of the tribe Coffeae (Rubiaceae) revealed a weakly supported clade containing *Tricalysia* A. Rich. and the allied genera *Argocoffeopsis* Lebrun, *Calycosiphonia* Pierre ex Robbr., *Belonophora* Hook. f., *Diplospora* DC., *Discospermum* Dalzell, *Nostolachma* T. Durand, and *Xantonnea* Pierre ex Pit. The phylogenetic relationships of *Tricalysia* and these allied taxa are investigated further using sequence data from four plastid regions (*trnL-F* intron and intergenic spacer, *rpl16* intron, *accD-psaI* intergenic spacer, and *PetD*). Our results demonstrate that *Tricalysia* sensu Robbrecht is not monophyletic. The genus name *Tricalysia* should be restricted to taxa from subgenus *Tricalysia*; subgenus *Empogona* (Hook. f.) Robbr. is sister to the genus *Diplospora* and is recognized at the generic level. The 34 necessary new combinations for *Empogona* Hook. f. are provided: *E. acidophylla* (Robbr.) J. Tosh & Robbr., *E. aequatoria* (Robbr.) J. Tosh & Robbr., *E. africana* (Sim) J. Tosh & Robbr., *E. aulacosperma* (Robbr.) J. Tosh & Robbr., *E. bequaertii* (De Wild.) J. Tosh & Robbr., *E. bracteata* (Hiern) J. Tosh & Robbr., *E. breteleri* (Robbr.) J. Tosh & Robbr., *E. buxifolia* (Hiern) J. Tosh & Robbr. subsp. *buxifolia*, *E. buxifolia* subsp. *australis* (Robbr.) J. Tosh & Robbr., *E. cacondensis* (Hiern) J. Tosh & Robbr., *E. concolor* (N. Hallé) J. Tosh & Robbr., *E. coriacea* (Sond.) J. Tosh & Robbr., *E. crepiniana* (De Wild. & T. Durand) J. Tosh & Robbr., *E. deightonii* (Brenan) J. Tosh & Robbr., *E. discolor* (Brenan) J. Tosh & Robbr., *E. filiformistipulata* (De Wild.) Bremek. subsp. *filiformistipulata*, *E. filiformistipulata* subsp. *epipsila* (Robbr.) J. Tosh & Robbr., *E. glabra* (K. Schum.) J. Tosh & Robbr., *E. gossweileri* (S. Moore) J. Tosh & Robbr., *E. kirkii* Hook. f. subsp. *junodii* (Schinz) J. Tosh & Robbr., *E. lanceolata* (Sond.) J. Tosh & Robbr., *E. macrophylla* (K. Schum.) J. Tosh & Robbr., *E. maputenis* (Bridson & A. E. van Wyk) J. Tosh & Robbr., *E. ngalaensis* (Robbr.) J. Tosh & Robbr., *E. nogueirae* (Robbr.) J. Tosh & Robbr., *E. ovalifolia* (Hiern) J. Tosh & Robbr. var. *ovalifolia*, *E. ovalifolia* var. *glabrata* (Oliv.) J. Tosh & Robbr., *E. ovalifolia* var. *taylorii* (S. Moore) J. Tosh & Robbr., *E. reflexa* (Hutch.) J. Tosh & Robbr. var. *reflexa*, *E. reflexa* var. *ivorensis* (Robbr.) J. Tosh & Robbr., *E. ruandensis* (Bremek.) J. Tosh & Robbr., *E. somaliensis* (Robbr.) J. Tosh & Robbr., *E. talbotii* (Wernham) J. Tosh & Robbr., and *E. welwitschii* (K. Schum.) J. Tosh & Robbr.

Key words: *accD-psaI*, *Coffea*, coffee, Coffeae, *Empogona*, molecular systematics, *petD*, *rpl16*, Rubiaceae, *Tricalysia*, *trnL-F*.

The genus *Tricalysia* A. Rich. is one of the largest genera of Rubiaceae in Africa and occurs in continental Africa (ca. 95 species), Madagascar (12 species), and the Comoros (one species). The genus typically possesses the distinguishing characteristics of the tribe Coffeae (Bridson & Verdcourt, 2003; Davis et al., 2007). These include axillary inflorescences paired at the nodes with obvious calyculi, flowers with left contorted corolla aestivation and a distinctly 2-lobed style, and relatively small and few-seeded fleshy fruits. Most *Tricalysia* species can be

separated readily from other Coffeae by the presence of stipules with needlelike awns, truncate to distinctly lobed calyces, and seeds with a shallow hilum. Identification of *Tricalysia* at the species level is notoriously difficult, as the genus contains a large number of species across a broad geographic and ecologic range, often separated by minor and continuous characters.

In a series of papers, Robbrecht (1978, 1979, 1982, 1983, 1987) conducted a taxonomic revision of *Tricalysia*, with later contributions by Ali and

¹James Tosh would like to acknowledge all members of the conservation genetics, molecular systematic, and Rubiaceae research groups at the Royal Botanic Gardens, Kew, who provided help and support during my research visit in 2006. The authors would also like to thank the reviewers of the paper for their helpful comments and suggestions. This research was supported financially by grants from the Fund for Scientific Research–Flanders (FWO, G.0250.05 and G.0268.04).

²Laboratory of Plant Systematics, Katholieke Universiteit Leuven, Kasteelpark Arenberg 31, P.O. Box 2437, BE-3001 Leuven, Belgium. Corresponding author: james.tosh@bio.kuleuven.be.

³Royal Botanic Gardens, Kew, Richmond, Surrey, TW9 3AE, United Kingdom.

⁴National Botanic Garden of Belgium, Domein van Bouchout, BE-1860 Meise, Belgium.

⁵National Herbarium of The Netherlands, Leiden University Branch, P.O. Box 9514, NL-2300 RA Leiden, The Netherlands. doi: 10.3417/2006202

Robbrecht (1991) and Ranarivelo-Randriamboavonjy et al. (2007). Robbrecht (1979, 1982, 1983, 1987) recognized and revised two subgenera: subgenera *Tricalysia* A. Rich with five sections (*Probletostemon* (K. Schum.) Robbr., *Tricalysia*, *Rosea* (Klotzsch) Robbr., *Ephedranthera* Robbr., and an unnamed Madagascan section) and subgenus *Empogona* (Hook. f.) Robbr. with two sections (*Empogona* Hook. f. and *Kraussiopsis* Robbr.). Separation of the two subgenera in *Tricalysia* was supported by differences in calyx lobe morphology, corolla throat pubescence, fruit color, and the presence/absence of a sterile appendage on the anther connective.

Empogona Hook. f. was originally recognized at the generic level by Hooker (1873) based on a single Zambebian species, *E. kirkii* Hook. f. Brenan (1947) reduced the genus *Empogona* to a section of *Tricalysia*, containing six mainly eastern and southern African species. During his revision of *Tricalysia* and, in particular, his treatment of subgenus *Empogona*, Robbrecht (1979) showed that ca. 20 other tropical African species, many of them with Guineo-Congolian distribution, also belonged to this subgenus.

Robbrecht (1978) also investigated the closely related genus *Neorosea* N. Hallé, consisting of 17 species, many of which were formerly included in *Tricalysia*. Two of these 17 species, including the type species *N. jasminiflora* (Klotzsch) N. Hallé, proved to be genuine *Tricalysia* species; a new genus, *Sericanthe* Robbr., was described to accommodate the remaining species (Robbrecht, 1978).

The close association between *Diplospora* DC. and *Discospermum* Dalzell with *Tricalysia* has long been recognized, with some authors (e.g., Schumann, 1891) considering *Diplospora* and *Tricalysia* to be synonymous. Ali and Robbrecht (1991) broadly surveyed *Diplospora* and *Discospermum* and enumerated a whole suite of characters that could be used to distinguish these Asian taxa from the closely related African *Tricalysia* species. They also justified *Diplospora* and *Discospermum* as separate genera on the basis of fruit morphology.

The most recent taxonomic work on *Tricalysia*, by Ranarivelo-Randriamboavonjy et al. (2007), focused on the unnamed Madagascan section that was alluded to, but not treated by, Robbrecht (1987). Of the 12 species of *Tricalysia* occurring in Madagascar, only one species belongs to subgenus *Empogona* (*T. ovalifolia* Hiern). The other 11 species, characterized by the presence of unisexual flowers, belong to subgenus *Tricalysia*. Ranarivelo-Randriamboavonjy et al. (2007) observed that the Madagascan taxa could be accommodated within section *Tricalysia* were it not for the presence of unisexual flowers. As a result, they

formally placed these 11 taxa in *Androgyne* Robbr., a new section within subgenus *Tricalysia*.

Recent phylogenetic investigations incorporating morphological and molecular data sets have enabled us to improve our understanding of the systematic position of *Tricalysia* and its relationships with associated genera (Andreasen & Bremer, 2000; Persson, 2000; Bridson & Verdcourt, 2003; Robbrecht & Manen, 2006; Davis et al., 2007). Andreasen and Bremer (2000) assessed tribal and generic delimitation in subfamily Ixoroideae using morphology, plastid and nuclear ribosomal DNA sequences, and restriction site (restriction fragment length polymorphism) data. Their results highlighted the close affinity between *Coffea* L. and *Psilanthus* Hook. f. (Coffeeae s. str.) and several members of the Gardenieae subtribe Diplosporinae (*Diplospora* and *Tricalysia*), resulting in an expanded circumscription of the tribe Coffeeae to include *Tricalysia*, *Diplospora*, *Discospermum*, *Sericanthe*, *Coffea*, *Psilanthus*, and *Bertiera* Aubl. Bridson and Verdcourt (2003) further enlarged and modified the concept of Coffeeae on the basis of morphology and provisional plastid data (provided by A. P. Davis, unpublished). In contrast to the studies of Andreasen and Bremer (2000) and a broader study of the Rubiaceae (Robbrecht & Manen, 2006), the genus *Bertiera* was excluded from Coffeeae and placed in its own tribe, Bertiereae.

Davis et al. (2007) reexamined the circumscription and phylogeny of Coffeeae and *Bertiera* using sequence data from three plastid regions (*trnL-F* intron and intergenic spacer, *accD-psaI*, and *rpl16*) in combination with morphological data. Their study confirmed the placement of *Tricalysia* and related taxa (*Sericanthe*, *Diplospora*, and *Discospermum*) with *Coffea* and *Psilanthus*, and expanded Coffeeae to include six other genera (*Argocoffeopsis* Lebrun, *Belonophora* Hook. f., *Nostolachma* T. Durand, *Calycosiphonia* Pierre ex Robbr., and *Xantonnea* Pierre ex Pit.). However, this study only surveyed a limited number of *Tricalysia* species, all of which belong to subgenus *Tricalysia*. *Bertiera* was excluded from Coffeeae and retained in Bertiereae, in agreement with Bridson and Verdcourt (2003), and Gardenieae subtribe Diplosporinae was placed in synonymy with Coffeeae.

The current investigation uses DNA sequence data to test the monophyly of *Tricalysia* as currently circumscribed and to assess the accuracy of the subgeneric classification for the genus (Robbrecht, 1979, 1982, 1983, 1987). This is the first molecular study to include widespread and representative sampling of *Tricalysia*. In addition, we reassess the phylogenetic relationships within the broadly circumscribed Coffeeae, with an expanded sampling from both subgenera of *Tricalysia*. Given the wealth of *trnL-F*, *rpl16*, and *accD-psaI* sequence data already

Table 1. Summary of species from *Tricalysia* subgen. *Empogona* and subgen. *Tricalysia* sampled in this study (following classification of Robbrecht, 1979, 1982, 1983, 1987).

A) <i>Tricalysia</i> subgen. <i>Empogona</i> (ca. 27 spp., Robbrecht, 1979)		
Section	Species group	Species
<i>Tricalysia</i> sect. <i>Empogona</i> Hook. f. 12 spp. sensu Robbrecht, 1979	<i>T. discolor</i> group	<i>T. acidophylla</i> Robbr.
	<i>T. junodii</i> group	<i>T. junodii</i> (Schinz) Brenan
		<i>T. ngalaensis</i> Robbr.
		<i>T. ovalifolia</i> Hiern
	No known group affiliation within sect.	<i>T. concolor</i> N. Hallé
	<i>Empogona</i>	<i>T. gossweileri</i> S. Moore
<i>Tricalysia</i> sect. <i>Kraussiopsis</i> Robbr. 15 spp. sensu Robbrecht, 1979	<i>T. crepiniana</i> group	<i>T. bequaertii</i> De Wild.
		<i>T. talbotii</i> (Wernham) Keay
	<i>T. ruandensis</i> group	<i>T. cacondensis</i> Hiern
		<i>T. lanceolata</i> (Sond.) Burt Davy
		<i>T. ruandensis</i> Bremek.
B) <i>Tricalysia</i> subgen. <i>Tricalysia</i> (ca. 75 spp., Robbrecht, 1982, 1983, 1987)		
Section	Species group	Species
<i>Tricalysia</i> sect. <i>Probletostemon</i> (K. Schum.) Robbr. 4 spp. sensu Robbrecht, 1983		<i>T. anomala</i> E. A. Bruce
		<i>T. elliotii</i> (K. Schum.) Hutch. & Dalziel
<i>Tricalysia</i> sect. <i>Ephedranthera</i> Robbr. 9 spp. sensu Robbrecht, 1982		<i>T. aciculiflora</i> Robbr.
		<i>T. acocantheroides</i> K. Schum.
		<i>T. bridsoniana</i> Robbr.
<i>Tricalysia</i> sect. <i>Tricalysia</i> 40 spp. sensu Robbrecht, 1987	<i>T. angolensis</i> group	<i>T. griseiflora</i> K. Schum.
	Core group for sect. <i>Tricalysia</i>	<i>T. bagshawei</i> S. Moore
		<i>T. coriacea</i> (Benth.) Hiern
		<i>T. microphylla</i> Hiern
		<i>T. okelensis</i> Hiern
		<i>T. pallens</i> Hiern
<i>Tricalysia</i> sect. <i>Rosea</i> (Klotzsch) Robbr. 9 spp. sensu Robbrecht, 1987		<i>T. jasminiflora</i> (Klotzsch) Benth. & Hook. f. ex Hiern
		<i>T. schliebenii</i> Robbr.
<i>Tricalysia</i> sect. <i>Androgyne</i> Robbr. 11 spp. sensu Ranarivelo-Randriamboavonjy et al., 2007		<i>T. ambrensis</i> Randriamb. & De Block
		<i>T. analamazaotrensis</i> Homolle ex Randriamb. & De Block
		<i>T. cryptocalyx</i> Baker
		<i>T. dauphinensis</i> Randriamb. & De Block
		<i>T. leucocarpa</i> (Baill.) Randriamb. & De Block
		<i>T. perrieri</i> Homolle ex Randriamb. & De Block

Table 2. Amplification primers used in this study.

Region	Primer	Primer sequence (5'-3')	Reference
<i>trnL-F</i>	Forward (c)	CGA AAT CGG TAG ACG CTA CG	Taberlet et al., 1991
	Reverse (f)	AAT TGA ACT GGT GAC ACG AG	
<i>rpl16</i>	Forward (71f)	GCT ATG CTT AGT GTG TGA CTC GTT G	Jordan et al., 1996
	Reverse (1661r)	CGT ACC CAT ATT TTT CCA CCA CGA C	Shaw et al., 2005
	Reverse (1516r)	CCC TTC ATT CTT CCT CTA TGT TG	
	Internal forward	GTA AGA AGT GAT GGG AAC GA	Davis et al., 2007
<i>accD-psaI</i>	Internal reverse	TCG TTC CCA TCA CTT CTT AC	Mendenhall, 1994
	Forward (769 F)	GGA AGT TTG AGC TTT ATG CAA ATG	
<i>petD</i>	Reverse (75 R)	AGA AGC CAT TGC AAT TGC CGG AAA	Löhne & Borsch, 2004
	Forward (1365)	TTG ACY CGT TTT TAT AGT TTA C	
	Reverse (738)	AAT TTA GCY CTT AAT ACA GG	

available for *Coffeae* (Davis et al., 2007), we have focused on these three plastid regions in the current investigation and included further sequence data from the plastid region *petD*.

MATERIALS AND METHODS

TAXON SAMPLING

An expanded sampling of *Tricalysia*, *Diplospora*, *Discospermum*, *Sericanthe*, and *Bertiera* was combined with sequence data generated by Davis et al. (2007). *Tricalysia* samples representing both subgenera and all of the seven sections of the genus (Robbrecht, 1979, 1982, 1983, 1987) were included in the analyses (Table 1). Representative taxa from *Ixoreae*, *Octotropideae*, and *Gardenieae* were selected as the outgroup. A list of the 80 accessions used in the study is given in Appendix 1.

DNA EXTRACTION, POLYMERASE CHAIN REACTION AMPLIFICATION, AND SEQUENCING

Most DNA samples were obtained from silica gel collections or, alternatively, from seed, flower, or leaf samples taken from herbarium specimens (BR, K, MO, WAG). A small number of DNA samples were obtained from fresh leaf material collected from the living collections of the National Botanic Garden of Belgium.

For silica gel samples, DNA was isolated using a modified DNA Mini Extraction Protocol (Royal Botanic Gardens, Kew [K] protocol). DNA samples were obtained from herbarium material using the 2× CTAB protocol of Doyle and Doyle (1987), with the DNA subsequently purified using cesium chloride/ethidium bromide gradients and concentrated by dialysis before inclusion in the DNA Bank at K. All DNA samples were purified using a NucleoSpin purification column (Macherey-Nagel, Bethlehem,

Pennsylvania, U.S.A.) according to the manufacturer's instructions in order to remove any potential polymerase chain reaction (PCR) inhibitors.

Amplification of the *trnL-F*, *rpl16*, *petD*, and *accD-psaI* plastid regions was carried out using the primers listed in Table 2. Amplification of the *rpl16* region was primarily carried out using the forward primer 71f and the reverse primers 1661r (Jordan et al., 1996) and 1516R (Shaw et al., 2005), although *Coffeae* specific internal primers designed by K were also required for certain taxa (Davis et al., 2007).

All PCR and sequencing reactions were performed using a Perkin Elmer (Waltham, Massachusetts, U.S.A.) GeneAmp 9700 Thermal Cycler machine. Amplification of *trnL-F* was carried out using the following profile: 94°C for 3 min.; 32 cycles of 94°C for 1 min., 51°C for 1 min., 72°C for 2 min.; and a final extension of 72°C for 7 min. *accD-psaI* and *rpl16* were amplified as follows: 94°C for 3 min.; 32 cycles of 94°C for 1 min., 52°C for 1 min., 72°C for 1 min. 30 sec.; and a final extension of 72°C for 7 min. Amplification of *petD* was carried out as follows: 96°C for 2 min.; 34 cycles of 94°C for 1 min., 50°C for 1 min., 72°C for 1 min. 30 sec.; and a final extension of 72°C for 10 min.

For the *trnL-F*, *petD*, and *rpl16* regions, 25 µl PCR reactions were made using a commercial PCR master mix (2.5 mM MgCl₂ ReddyMix; ABgene; Epsom, Surrey, U.K.). *accD-psaI* did not amplify successfully with the commercial master mix, so 25 µl PCR master mixes were prepared using Biotaq DNA polymerase (Bioline, London, U.K.), 2.5 µl of 10× NH₄ reaction buffer (Bioline), 1.5 µl of 50 mM MgCl₂, and 2.5 µl of dNTPs (Promega, Madison, Wisconsin, U.S.A.). All amplified PCR products were purified using NucleoSpin purification columns following the manufacturer's protocol.

Cycle sequencing reactions were carried out using BigDye Terminator Mix version 3.1 (Applied Biosystems, Inc., Warrington, Cheshire, U.K.). The cycle

sequence reaction consisted of 26 cycles of 10 sec. at 96°C, 5 sec. at 50°C, and 4 min. at 60°C. Cycle sequencing products were cleaned with the MagneSil Clean-Up System (Promega) using an automated robot (Biomek NX S8; Beckman Coulter, High Wycombe, Buckinghamshire, U.K.). Analysis of cycle sequencing products was performed using an AB 3730 DNA Analyzer (Applied Biosystems). In addition, a number of the *trnL-F* and *petD* samples were sent to Macrogen (Seoul, South Korea) for sequencing.

ALIGNMENT AND GAP CODING

Sequences were assembled and edited using the Staden software package (Staden et al., 1998). All sequences were aligned manually in MacClade (version 4.04, Maddison & Maddison, 2002). Low levels of sequence variation enabled sequences to be aligned without difficulty. Regions of ambiguous alignment, such as the beginning and end of sequences, were removed. The edited sequences were analyzed with gaps treated as missing data and phylogenetically informative indels (insertions and/or deletions) coded according to the "simple indel coding" method of Simmons and Ochoterena (2000).

PHYLOGENETIC ANALYSES

Phylogenetic analyses were performed on the four separate plastid data sets in addition to the combined four-region plastid matrix.

Maximum parsimony. Heuristic tree searches were carried out in PAUP* version 4.0b10 (Swofford, 2003) using 10,000 replicates of random taxon sequence addition, holding 10 trees at each step, with tree bisection-reconnection (TBR) branch swapping, delayed transformation (DELTRAN) optimization, and MULTREES in effect, and saving no more than 10 trees per replicate. Support values for clades recovered in the analyses were estimated using bootstrap analysis (Felsenstein, 1985). One thousand replicates of simple sequence addition, TBR swapping, and saving 10 trees per replicate were performed in PAUP*. We interpreted bootstrap values greater than 85% as being well supported, 75%–84% as being moderately supported, and 50%–74% as having low support.

Bayesian inference. Evolutionary models for each plastid region were selected using Modeltest v3.06 (Posada & Crandall, 1998) under the Akaike information criterion. In the case of *accD-psaI*, *petD*, and *rpl16*, the nucleotide substitution model that best fits the data was HKY + I + G. The HKY + I model

was selected for the *trnL-F* sequence matrix. The combined data set was partitioned into five discrete units. In addition to the four plastid regions, there was a fifth partition for the phylogenetically informative indels. The restriction site (binary) model of evolution was implemented for the indel data, following the recommendation of Ronquist et al. (2005). Four independent Bayesian searches, each consisting of two simultaneous parallel analyses, were carried out using MrBayes 3.1 (Huelsenbeck & Ronquist, 2001). In each Bayesian analysis, four Markov chains (three heated, one cold) were run simultaneously for 2,000,000 generations, sampling trees every 100 generations. The initial 25% of trees were discarded as a conservative burn-in. After confirming by eye that trees generated from separate analyses had consistent topologies, the "post-burn-in" trees from each analysis were pooled together, imported into PAUP* version 4.0b10 (Swofford, 2003), and summarized by majority rule consensus, with values on the tree equating to posterior probabilities (PP).

RESULTS

This study generated 229 sequences, which were combined with the 75 sequences obtained by Davis et al. (2007). In total, this study included 79 *accD-psaI* sequences (53 newly generated), 80 *trnL-F* sequences (54 newly generated), 78 *rpl16* sequences (55 newly generated), and 67 *petD* sequences (all newly generated). The *rpl16* region proved to be the most problematic region to amplify, due in part to two poly-A stretches (one 373 bp from the 5' end, the other 466 bp from the 3' end). As a result, it was often difficult to obtain sufficient overlap during sequence assembly. Internal primers, designed specifically for Coffeae taxa (Davis et al., 2007), were used to obtain a complete sequence for *rpl16* in problematic taxa.

In general, the amount of genetic variability in all plastid regions was low (Table 3). A large proportion of the total genetic variation occurred between the ingroup (Coffeae) taxa and outgroup (other Ixoroideae). We observed considerable length variability in the *accD-psaI* region. As with all the plastid regions investigated, *accD-psaI* is particularly AT-rich and subject to several repeat units, giving rise to a number of potentially phylogenetically informative indels. In the case of *Tricalysia* subgen. *Empogona*, all taxa included in the study share a 250 bp deletion in the *accD-psaI* region. Less length variation was observed in *petD*, *rpl16*, and *trnL-F*. The gross tree topologies of all four individual analyses were examined by eye and found to be topologically consistent, and the four data sets were subsequently combined in all further analyses.

Table 3. Characteristics of *accD-psal*, *rpl16*, *petD*, *trnL-F*, and combined data sets and tree statistics.

	<i>accD-psal</i>	<i>rpl16</i>	<i>petD</i>	<i>trnL-F</i>	Combined plastid
No. of taxa	79	78	67	80	80
Total length (base pairs)	1255	1207	1064	889	4415
Sequence length variation	737–1061	995–1068	937–966	772–822	—
No. of constant characters	1075	982	974	765	3796
No. of phylogenetically informative indels	22	11	8	9	50
No. of variable PI characters (% of total characters)	117 (9.3)	116 (9.6)	45 (4.2)	74 (8.3)	352 (7.9)
Tree length	283	339	123	174	929
Consistency index	0.827	0.814	0.854	0.822	0.816
Retention index	0.923	0.890	0.937	0.916	0.908
No. of trees saved	9920	1056	1392	9990	8853

The aligned combined matrix had a total length of 4465 bp. There were 669 variable characters and, of these, 352 characters were parsimony informative (7.9% of total number of characters). In total, the matrix contained 50 parsimony informative indels, consisting of repeat sequences in addition to insertion/deletion events. Exclusion of outgroup taxa (Ixoreae, Gardenieae, Octotropideae, and Bertierieae) revealed 211 parsimony informative characters within Coffeae.

PHYLOGENETIC RESULTS

The heuristic maximum parsimony (MP) analysis of the combined plastid data matrix generated 8853 most parsimonious trees with a length of 929 steps, a consistency index (CI) of 0.816, and a retention index (RI) of 0.908. Table 3 summarizes the tree statistics for the individual and combined analyses.

The topologies of the MP strict consensus tree and the Bayesian majority rule tree (Fig. 1) were consistent with each other. Figure 2 displays one of the most parsimonious trees and indicates both bootstrap support (BS) and branch length. Both MP and Bayesian analyses reconfirm the monophyly of the ingroup (BS 99%, PP 1.00). *Bertiera*, here represented by its two subgenera, is monophyletic (BS 100%, PP 1.00) and is sister to the ingroup (BS 79%, PP 1.00).

The clade of *Coffea* and *Psilanthus* is well supported (BS 100%, PP 1.00) and is sister to the remaining ingroup taxa (BS 93%, PP 1.00). There is also strong support for the clade of *Argocoffeopsis* and *Calycosiphonia* (BS 99%, PP 1.00). The sister relationship of *Calycosiphonia* and *Argocoffeopsis* to the rest of the ingroup receives weak bootstrap support (BS 50%), but is supported by a PP of 0.98.

Both MP and Bayesian analyses recovered a clade including *Sericanthe*, *Diplospora*, *Discospermum*, and *Tricalysia* subgen. *Empogona*. Although there is no bootstrap support for this clade (BS < 50%), the clade does receive support in the Bayesian analyses (PP 0.98). Within this clade, there is strong support for the monophyly of *Sericanthe* (BS 99%, PP 1.00), *Discospermum* (BS 100%, PP 1.00), and the group of *Diplospora* and *Tricalysia* subgen. *Empogona* (BS 99%, PP 1.00). The monophyly of both *Diplospora* (BS 90%, PP 1.00) and *Tricalysia* subgen. *Empogona* (BS 98%, PP 1.00) is confirmed. Within *Tricalysia* subgen. *Empogona*, two groups receive high levels of support: the group of *T. cacondensis* Hiern, *T. lanceolata* (Sond.) Burt Davy, and *T. ruandensis* Bremek. (BS 85%, PP 1.00); and the group of *T. junodii* (Schinz) Brenan, *T. ovalifolia*, and *T. acidophylla* Robbr. (BS 98%, PP 1.00).

The clade of *Belonophora* and *Tricalysia* subgen. *Tricalysia* is present in both the MP strict consensus

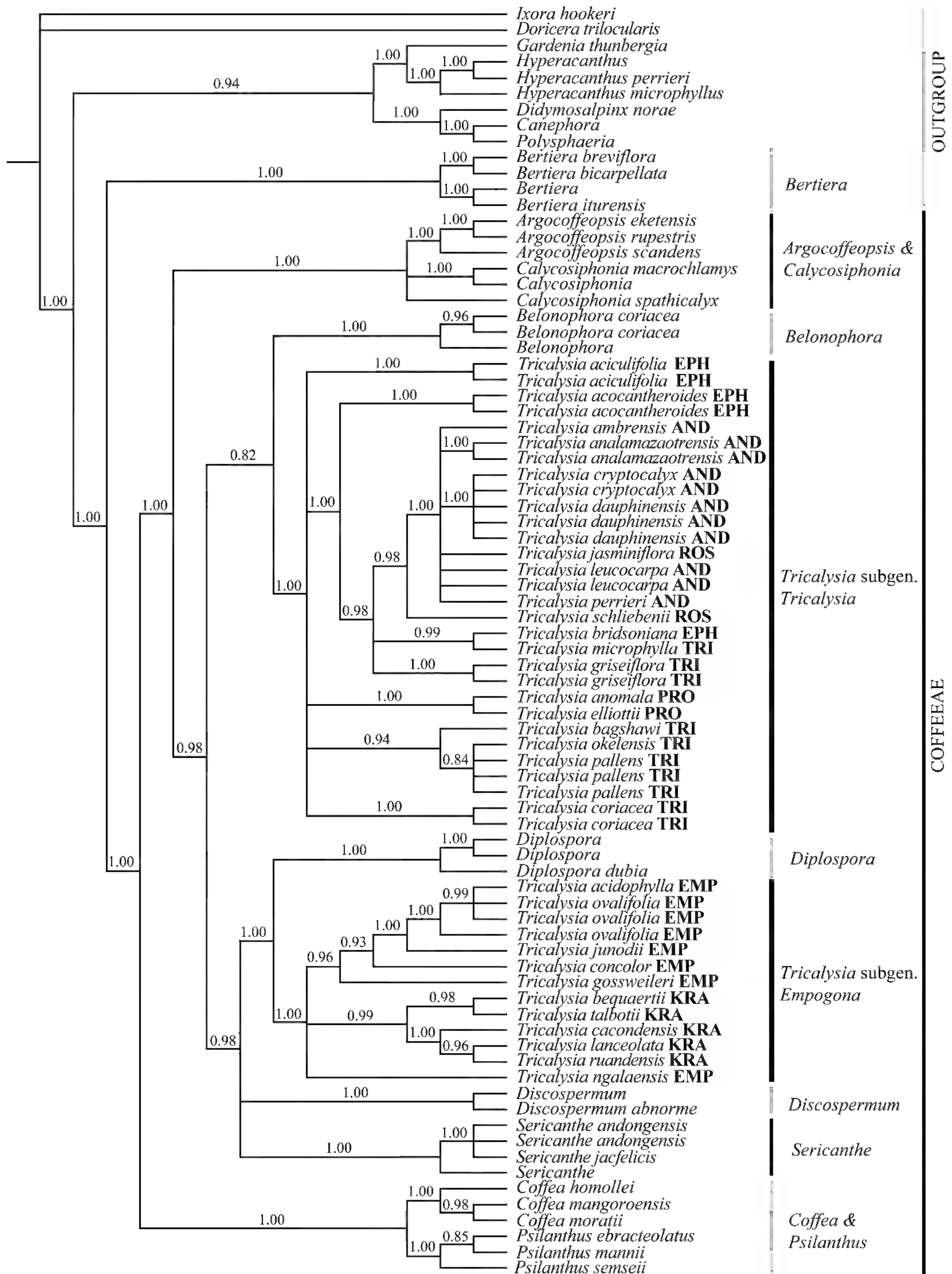

Figure 1. Maximum parsimony strict consensus/Bayesian majority rule consensus tree. Bayesian posterior probabilities are indicated above branches. Sectional groupings are annotated after species names: AND, *Tricalysia* sect. *Androgyne*; EMP, *Tricalysia* sect. *Empogona*; EPH, *Tricalysia* sect. *Ephedranthera*; KRA, *Tricalysia* sect. *Kraussiopsis*; PRO, *Tricalysia* sect. *Probletostemon*; ROS, *Tricalysia* sect. *Rosea*; TRI, *Tricalysia* sect. *Tricalysia*. See Table 1 for species authorities and provenance.

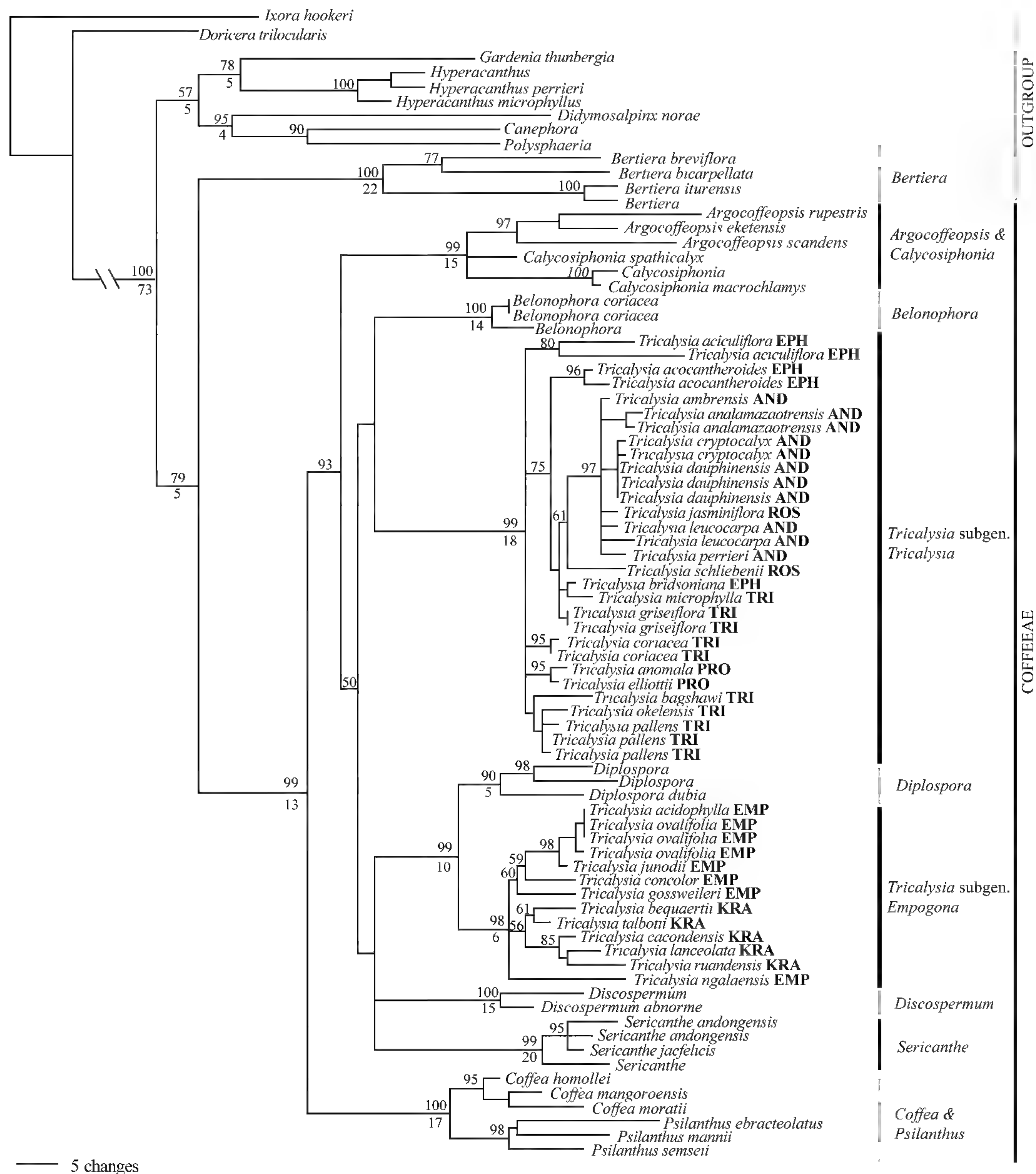

Figure 2. One of the 8853 most parsimonious trees generated in the maximum parsimony analysis. Bootstrap values > 50% are indicated above branches, and selected branch lengths are indicated below branches. Sectional groupings are annotated after species names: AND, *Tricalysia* sect. *Androgyne*; EMP, *Tricalysia* sect. *Empogona*; EPH, *Tricalysia* sect. *Ephedranthera*; KRA, *Tricalysia* sect. *Kraussiopsis*; ROS, *Tricalysia* sect. *Rosea*; PRO, *Tricalysia* sect. *Probletostemon*; TRI, *Tricalysia* sect. *Tricalysia*. See Table 1 for species authorities and provenance.

tree and the Bayesian majority rule tree, although there is negligible support for this clade (BS < 50%, PP 0.82). However, the monophyly of *Belonophora* (BS 100%, PP 1.00) and *Tricalysia* subgen. *Tricalysia* (BS 99%, PP 1.00) is strongly supported. Within *Tricalysia* subgen. *Tricalysia*, several groups receive strong support: the group of *T. elliotii* (K. Schum.) Hutch. &

Dalziel and *T. anomala* E. A. Bruce (BS 95%, PP 1.00), and a group of predominantly Madagascan taxa with the inclusion of *T. jasminiflora* (Klotzsch) Benth. & Hook. f. ex Hiern (BS 97%, PP 1.00). There is also moderate bootstrap (BS 75%) and high PP (PP 1.00) for the clade of *T. acocantheroides* K. Schum., *T. griseiflora* K. Schum., *T. bridsoniana* Robbr., *T.*

microphylla Hiern, *T. schliebenii* Robbr., and the aforementioned Madagascan group together with *T. jasminiflora*.

DISCUSSION

Previous taxonomic work on *Tricalysia* has focused on the use of traditional morphological and anatomical characters to infer relationships within the genus. In the most recent classification of the genus, Robbrecht (1979, 1982, 1983, 1987) subdivided it into two subgenera and seven sections. Here, for the first time, we have addressed relationships in this group using molecular data.

In the current investigation, we obtained sequence data from four plastid regions for both subgenera and all seven sections of *Tricalysia* and generated estimates of phylogeny using both MP and Bayesian inference methods. The consensus tree topologies of both analyses (strict consensus for MP, majority rule consensus for Bayesian) were consistent. As is often observed, Bayesian PP were higher than bootstrap support values for any given node (Huelsenbeck et al., 2002; Erixon et al., 2003; Randle et al., 2005).

TESTING THE MONOPHYLY OF THE GENUS *TRICALYSIA*

Our phylogenetic analyses indicate that *Tricalysia*, as currently circumscribed, is not monophyletic. The monophyly of subgenera *Tricalysia* and *Empogona* is confirmed, but they are not sister to each other. This represents a new, though perhaps unsurprising, observation, which has implications for the taxonomy of the group (see below).

Davis et al. (2007) included five species of *Tricalysia* in their molecular and morphological reassessment of the circumscription and phylogeny of Coffeae. All five species were representatives of subgenus *Tricalysia*. In both their combined molecular and combined morphological-molecular phylogenies, *Tricalysia* (subgen. *Tricalysia*) was placed in a poorly supported and unresolved clade containing *Sericanthe*, *Belonophora*, and an Asian clade (including *Diplospora* and *Discospermum*). The study of Davis et al. (2007) incorporated molecular data from three plastid regions (*trnL-F*, *accD-psaI*, and *rpl16*). In our investigation, we included an additional plastid region, the group II intron *petD*. The extra characters provided by this fourth plastid marker were still not sufficient to fully elucidate systematic relationships within the clade containing *Tricalysia* subgen. *Tricalysia*, *Sericanthe*, *Belonophora*, *Diplospora*, and *Discospermum*.

The inclusion of taxa from *Tricalysia* subgen. *Empogona* led to results conflicting with the study

of Davis et al. (2007). First, we did not recover an Asian clade. Instead, *Diplospora* formed a well-supported monophyletic group with *Tricalysia* subgen. *Empogona* (BS 99%, PP 1.00). Second, both the MP strict consensus tree and the Bayesian majority rule consensus tree indicated sister relationships between *Tricalysia* subgen. *Tricalysia* and *Belonophora*, and recovered a clade containing *Sericanthe*, *Discospermum*, *Diplospora*, and *Tricalysia* subgen. *Empogona*. The clade of *Belonophora* and subgenus *Tricalysia* received poor internal support (BS < 50%, PP 0.82), but there was support for the second clade in the Bayesian analysis (BS < 50%, PP 0.98).

TAXONOMIC IMPLICATIONS FOR GENERIC CONCEPTS

The revelation that *Tricalysia* sensu Robbrecht is not monophyletic calls for a reconsideration of the taxonomic delimitation of *Tricalysia* and closely related taxa. One taxonomic option would be to widen the genus *Tricalysia* to include *Belonophora*, *Diplospora*, *Discospermum*, and *Sericanthe*. However, these genera are easily identified (e.g., by the use of a key) and are so diverse morphologically and anatomically that consolidating them into one genus does not seem justified (Table 4). A more logical option would be to separate these taxa into groups at the generic level, based on morphological and molecular synapomorphies.

Robbrecht (1979) enumerated four potential field characters that distinguish the subgenera *Empogona* and *Tricalysia*. Taxa of subgenus *Empogona* are identified by the presence of distinctly lobed calyces (vs. short and truncate in subgenus *Tricalysia*), densely pubescent corolla throats (vs. glabrous to sparsely hairy), the presence of a large flattened sterile appendage protruding from the anther connective (vs. blunt anthers, occasionally forming a short triangular appendage), and fruits that turn black at maturity (vs. red fruits). Robbrecht (1979) considered recognizing *Empogona* at the generic rank, but opted to incorporate it as a subgenus of *Tricalysia*, given the similarity in a number of other key characters (placentation, pollen morphology, fruit and seed morphology, and seed coat anatomy). This decision was also pragmatic in terms of taxonomic stability, as it required the fewest nomenclatural changes (Robbrecht, 1979).

The revision of *Sericanthe* (Robbrecht, 1978) and the survey of the Asian relatives of *Tricalysia* (Ali & Robbrecht, 1991) provided ample morphological and anatomical evidence to justify the exclusion of these genera from *Tricalysia*. The genus *Sericanthe* is distinguished from *Tricalysia* by the presence of bacterial leaf galls (rare in Rubiaceae), wing-shaped

colleters, and pollen with a verrucate sexine (in contrast to the reticulate sexine occurring in all other members of Coffeae). Davis et al. (2007) also presented the following synapomorphic characters for the genus: 7- to 9-merous flowers, distinctly basifixed anthers, and horizontal micropyle orientation.

Diplospora and *Discospermum* consistently have tetramerous flowers, which occur only rarely in African *Tricalysia*, and the flowers of Asian taxa are smaller than their African counterparts (Ali & Robbrecht, 1991). In addition, there is a strong tendency toward unisexual flowers in Asian taxa, a trait that is absent in all but a few representatives of *Tricalysia* confined to Madagascar (Ranarivelo-Randriamboavonjy et al., 2007). Ali and Robbrecht (1991) also justified maintaining *Diplospora* and *Discospermum* as separate genera on the basis of rather divergent fruit types (small, fleshy, and red fruits in *Diplospora* and large, leathery, and purplish black fruits in *Discospermum*). The decision to maintain *Diplospora* and *Discospermum* as separate genera is also supported by our molecular analyses.

The tribal position of *Belonophora* has been fairly unstable since its initial description by Hooker (1873), partly due to the erroneous observation by Hooker that *Belonophora* possesses a solitary, pendulous ovule in each of the two locules. Keay (1958) observed that *Belonophora* species actually possess two collateral ovules per locule, on the inner surface of a pendulous placenta, but he felt it premature to assign the genus to a new tribe until a more satisfactory tribal classification within Rubiaceae had been proposed. Robbrecht and Puff (1986) tentatively placed *Belonophora* in the tribe Aulacocalyceae, although the axillary inflorescences of *Belonophora* contrasted with the terminal or subterminal inflorescences possessed by other members of the tribe. The placement of *Belonophora* in the tribe Coffeae was first proposed by Bridson and Verdcourt (2003) and later supported by the study of Davis et al. (2007). The imbricate calyx lobes of *Belonophora* were synapomorphic for the genus in the study of Davis et al. (2007), and the genus is also distinguished from other members of Coffeae by the presence of a superior embryo radicle (Cheek & Dawson, 2000).

In light of evidence from our own molecular investigation, and in combination with morphological and anatomical observations reported elsewhere, we believe it is appropriate and fully justified to recognize *Empogona* (sensu Robbrecht, 1979) at generic rank. The necessary taxonomic changes for the inclusion of many former *Tricalysia* species in the genus *Empogona* are provided at the end of the Discussion.

RECOGNITION OF INTRAGENERIC GROUPS IN *TRICALYSIA*

In addition to testing the monophyly of *Tricalysia* sensu Robbrecht, we were able to assess the levels of support for his sectional groups within the genus. All seven sections were sampled in our analysis, although some were better represented. Low levels of genetic variation between species limited the amount of resolution between taxa, but there are some provisional findings from this study.

Tricalysia subgen. *Tricalysia* was subdivided into five sections by Robbrecht (1982, 1983, 1987). *Tricalysia* sect. *Probletostemon*, here represented in our molecular study by *T. elliotii* and *T. anomala* (Table 1), was thought to possess many morphological and anatomical features regarded as primitive for the group. These included free bracteoles, standard colleters (Robbrecht, 1988), large pleiomerous flowers with many ovules per placenta, and large fruits (Robbrecht, 1983). Our study confirms the monophyly of section *Probletostemon* (BS 95%, PP 1.00), but it remains unresolved in a basal polytomy.

Tricalysia sect. *Ephedranthera*, here represented by three species, is characterized by the presence of anthers that are sessile in the corolla throat and partly included within the corolla tube (Robbrecht, 1982). The monophyly of this section is not supported in our investigation. *Tricalysia aciculiflora* Robbr. falls within the basal polytomy, whereas *T. aco-cantheroides* and *T. bridsoniana* are situated within the moderately to well-supported clade (BS 75%, PP 1.00) containing all the remaining taxa of subgenus *Tricalysia*.

The other three sections (*Tricalysia*, *Rosea*, and *Androgyne*) are very similar morphologically. Most species in subgenus *Tricalysia* belong to section *Tricalysia*, which Robbrecht (1987) further subdivided into four informal groups. Only two of these informal groups are included in this investigation. The core group of taxa within section *Tricalysia*, here represented by *T. coriacea* (Benth.) Hiern and the weakly supported clade of *T. pallens* Hiern, *T. okelensis* Hiern, and *T. bagshawei* S. Moore, is unresolved in the basal polytomy. The group of *T. angolensis* A. Rich. ex DC., represented by *T. griseiflora* K. Schum., falls within the clade containing *T. bridsoniana*, *T. microphylla*, and representatives from sections *Rosea* and *Androgyne*.

In section *Rosea*, species differ conspicuously from those in section *Tricalysia* due to the presence of a spathaceous calyx (Robbrecht, 1987). In section *Androgyne*, which comprises the Madagascan representatives of subgenus *Tricalysia*, species are characterized by the presence of unisexual flowers. There is weak bootstrap and significant Bayesian support

Table 4. Salient morphological characters of *Tricalysia* and close relatives. Characters in boldface represent unique features for *Empogona*. Figures in single parentheses = rarely; figures in double parentheses = very rarely.

	<i>Tricalysia</i> , excluding <i>Tricalysia</i> sect.				<i>Sericanthe</i> (ca. 20 spp.)	
	<i>Disospermum</i> (ca. 7 spp.)	<i>Diplospora</i> (ca. 10 spp.)	<i>Empogona</i> (29 spp.)	sect. <i>Androgynae</i> (11 spp.)		<i>Belonophora</i> (5 spp.)
Bracts and bracteoles	free or fused into calyculi	free or fused into calyculi	free alternate, sect. <i>Empogona</i> ; fused into calyculi, sect. <i>Kraussiopsis</i>	fused into calyculi; free alternate in sect. <i>Probletostemon</i>	lower bracts fused into calyculi; upper bracts free, opposite	fused into calyculi
Corolla length (mm)	8-15	5-10	(6-) 8-17	8-50	(10-) 20-30(-40)	(8-) 12-25
Flower organization	hermaphroditic or unisexual	hermaphroditic or unisexual	hermaphroditic	hermaphroditic ^a	hermaphroditic; heterostyly	hermaphroditic
Merosity	4	4-(1-5))	((4-)) 5(-6)	(4-) 5-6(-12)	((4-)) 5	(5-) 7-8(-9)
Calyx	tube short, rounded lobes present or absent	tube short, lobes mostly triangular	tube short, lobes well-developed and often overlapping	tube well-developed, lobes none, triangular or linear	tube short, lobes well-developed	tube well-developed, with minute teeth
Corolla throat	glabrous to bearded	glabrous or hairy	densely bearded^b	glabrous to hairy	glabrous	glabrous or hairy
Anthers	medifixed; on short filaments in throat, exerted	medifixed; on short filaments in throat, exerted	medifixed; on long filaments in throat, exerted	medifixed; on long filaments in throat, exerted	medifixed; sessile in tube, included	basifixed; on short filaments in throat, exerted
Anther connective	sometimes protruding in very short triangle	sometimes protruding in very short triangle	protruding in conspicuous ribbon-like appendages^c	mostly protruding in short triangle	protruding in short triangle	strongly flattened; no appendage
Placentation	(3-) 5-15 ovules on a circular to + hemi-ellipsoid placenta; attached to middle of the septum	1-3(-6) ovules on a hemi-circular to + hemi-ellipsoid placenta; attached to the middle of the septum	1-ca. 25 ovules on a hemi-circular to + hemi-ellipsoid placenta; attached to the middle of the septum	1-12 ovules on a hemi-circular to + hemi-ellipsoid placenta; attached to the middle of the septum	2 collateral ovules on inner face of a pendulous hemi-circular + hemi-ellipsoid placenta; attached to the apex of the septum	(1-) 2(-5) ovules on a hemi-circular + hemi-ellipsoid placenta; attached to the apex of the septum
Fruit (mm)	20-30	5-7	8-10	5-20	10-15	10-30

Table 4. Continued.

	<i>Discospermum</i> (ca. 7 spp.)	<i>Diplospora</i> (ca. 10 spp.)	<i>Empogona</i> (29 spp.)	<i>Tricalysia</i> , excluding sect. <i>Androgynae</i> (ca. 80 spp.)	<i>Tricalysia</i> sect. <i>Androgynae</i> (11 spp.)	<i>Belonophora</i> (5 spp.)	<i>Sericanthe</i> (ca. 20 spp.)
Fruit color	purplish black	turning from yellow and orange to red	first white, turning purple, then black	red, rarely orange	red	yellow	orange
Pericarp	sclerified or leathery	fleshy	fleshy	fleshy; rarely sclerotic, sect. <i>Probletostemon</i>	fleshy	fleshy	fleshy
Placental outgrowth	massive, mostly surrounding seeds	mostly none	none, with weak outgrowths in some spp.	mostly none	none	massive, surrounding seeds	mostly none; massive in some spp.
Endosperm	entire, ruminant in some spp.	entire or ruminant	entire, ruminant in some spp.	entire	entire	entire	entire
Embryo radicle	away from septum	inferior	inferior	inferior	inferior	superior	lateral

^a Heterostyly in section *Ephedranthera*.

^b Glabrous in a few species, e.g., *Empogona concolor*.

^c Some species with an inconspicuous appendix, e.g., *Empogona welwitschii*.

(BS 61%, PP 0.98) for a clade containing these two sections. *Tricalysia schliebenii* (section *Rosea*) is sister to a strongly supported clade (BS 97%, PP 1.00) containing members of section *Androgynae* and *T. jasminiflora* of section *Rosea*.

Robbrecht (1979) recognized two sections within subgenus *Empogona*: section *Empogona* is characterized by free bracteoles and distinct non-overlapping calyx lobes; in contrast, the bracteoles in section *Kraussiopsis* are fused to form calyculi, and the calyx lobes either touch or overlap each other (with the exception of *Tricalysia bequaertii* De Wild., where the calyx lobes are not touching). *Tricalysia ngalaensis* Robbr., previously thought to be closely related to *T. junodii* (Schinz) Brenan (Robbrecht, 1979), is in an unresolved position (Figs. 1, 2). There is weak bootstrap but significant Bayesian support for the monophyly of section *Kraussiopsis* (BS 56%, PP 0.99), and the informal group of *T. ruandensis* is also well supported (BS 85%, PP 100). The remaining taxa of section *Empogona* are weakly supported (BS 60%, PP 0.96), although the clade of *T. junodii*, *T. ovalifolia*, and *T. acidophylla* is well supported (BS 98%, PP 1.00).

OTHER RELATIONSHIPS WITHIN COFFEEAE AND THE
RELATIONSHIP TO *BERTIERA*

The sister relationship of *Bertiera* and Coffeeae is recovered with moderate bootstrap and significant Bayesian support (BS 79%, PP 100), although our outgroup sampling is not complete. In order to confirm this result, more extensive sampling of representative groups within subfamily Ixoroideae is needed. Robbrecht and Manen (2006) opted to place *Bertiera* in subtribe Bertierinae, sister to Coffeineae, as the characteristic features of *Bertiera* differ from those of Coffeeae. Davis et al. (2007) found only weak bootstrap support for the sister relationship between *Bertiera* and Coffeeae (BS < 40%) based on molecular data alone, and the sister relationship was not recovered following the addition of morphological characters in their combined molecular-morphological analysis. Based on the decision of Bridson and Verdcourt (2003), they opted to place *Bertiera* in the monogeneric tribe Bertiereae. Whether *Bertiera* is recognized at the tribal or subtribal level is still open to debate, but we agree with Davis et al. (2007: 321) that "Coffeeae, with the addition of new genera and the removal of *Bertiera*, is both scientifically coherent and practical."

In the three-region plastid analysis of Davis et al. (2007), *Coffea* and *Psilanthus* form a well-supported monophyletic clade supported by a bootstrap of 87%, and are placed sister to the rest of Coffeeae. This relationship is recovered in our four-region analysis,

with increased support values (BS 93%, PP 1.00). There was also strong support for the sister relationship between the well-supported *Argocoffeopsis* and *Calycosiphonia* clade and the remaining ingroup taxa in our Bayesian analysis (PP 0.98), but weak support for this relationship in the MP analysis (BS 50%). This relationship was also recovered in the strict consensus tree of Davis et al. (2007).

TAXONOMIC NOVELTIES RESULTING FROM THE GENERIC RESTRUCTURE OF *EMPOGONA*

An outline of an emended infrageneric classification for *Empogona* is provided below. It contains a formal new combination for one of the two sections recognized. The outline is followed by a checklist of species, providing all necessary new combinations at the species level and below.

OUTLINE OF AN EMENDED CLASSIFICATION FOR *EMPOGONA*

Empogona Hook. f., Hooker's Icon. Pl. 11: 72, t. 1091. 1871. TYPE: *Empogona kirkii* Hook. f.

Tricalysia subgen. *Empogona* (Hook. f.) Robbr., Bull. Jard. Bot. Natl. Belg. 49: 259. 1979.

The further synonymy of subgenus *Empogona* (Robbrecht, 1979: 259) remains applicable to the genus *Empogona*.

Empogona Hook. f. sect. **Empogona**. *Tricalysia* subgen. *Empogona* (Hook. f.) Robbr. sect. *Empogona* (Hook. f.) Brenan.

EMPOGONA KIRKII SPECIES GROUP

This corresponds to the group of *Tricalysia junodii* (Robbrecht, 1979: 269). The group comprises the species numbered 11, 18, 22, and 24 in the checklist below. The position of *Empogona ngalaensis* (species 22 below) was not confirmed by our molecular analysis.

EMPOGONA DISCOLOR SPECIES GROUP

This corresponds to the group of *Tricalysia discolor* (Robbrecht, 1979: 292). The group comprises the species numbered 1, 4, 6, and 14 in the checklist below. The group is only represented by *Empogona acidophylla* in the analysis, which falls in a clade corresponding to the previous species group.

Section *Empogona* further comprises the three species numbered 10, 17, and 25 in the checklist below. They were considered to be of isolated position (Robbrecht, 1979: 300). Two of these species (10. *E. concolor* and 17. *E. gossweileri*) are included in the

analysis. They have a basal position in the clade corresponding to section *Empogona*.

Empogona sect. **Kraussiopsis** (Robbr.) J. Tosh & Robbr., comb. nov. Basionym: *Tricalysia* subgen. *Empogona* sect. *Kraussiopsis* Robbr., Bull. Jard. Bot. Natl. Belg. 49: 309. 1979. TYPE: *Empogona crepiniana* (De Wild. & T. Durand) J. Tosh & Robbr.

EMPOGONA RUANDENSIS SPECIES GROUP

This corresponds to the group of *Tricalysia ruandensis* (Robbrecht, 1979: 310). The group comprises the species numbered 8, 9, 19, 26, and 27 in the checklist below.

EMPOGONA GLABRA SPECIES GROUP

This corresponds to the group of *Tricalysia glabra* (Robbrecht, 1979: 292). This small group comprises only two species, numbers 16 and 23 in the checklist below.

EMPOGONA CREPINIANA SPECIES GROUP

This corresponds to the group of *Tricalysia crepiniana* (Robbrecht, 1979: 329). It is the most speciose group comprising 11 species, numbered 2, 3, 5, 7, 12, 13, 15, 20, 21, 28, and 29 of the checklist below.

CHECKLIST OF SPECIES AND INFRASPECIFIC TAXA, INCLUDING TAXONOMIC NOVELTIES

The list below, ordered alphabetically, enumerates all known taxa of *Empogona*, including the four species (species numbered 3, 7, 21, and 27 below) treated or described after Robbrecht's (1979) revision. The infrageneric assignment of the species is given in the preceding section of the present paper. Taxa preceded by an asterisk (*) were included in the molecular analysis (see Table 1).

The checklist includes taxonomic novelties for all species, i.e., 34 new combinations and three modifications of infraspecific status. In his revision, Robbrecht (1979) used varietal status for all infraspecific taxa recognized. Here we reconsider the appropriateness of that treatment in applying du Rietz's criteria (as cited in Stace, 1991) for distinguishing subspecies and varieties. Therefore, when infraspecific taxa are allopatric and differing in several features, we propose subspecific rather than varietal status.

(*) **1. *Empogona acidophylla*** (Robbr.) J. Tosh & Robbr., comb. nov. Basionym: *Tricalysia acid-*

- ophylla* Robbr., Bull. Jard. Bot. Natl. Belg. 49: 292. 1979. TYPE: Tanzania. Eastern Usambaras, 2 mi. E of Sigi railway station, 27 July 1953, *R. B. Drummond & J. H. Hemsley 3490* (holotype, K!; isotypes, B!, BR!, LISU!, S!).
- 2. *Empogona aequatoria*** (Robbr.) J. Tosh & Robbr., comb. nov. Basionym: *Tricalysia aequatoria* Robbr., Bull. Jard. Bot. Natl. Belg. 48: 465. 1978. TYPE: [Democratic Republic of the Congo.] Congo belge. Yangambi, 4 Dec. 1937, *J. Louis 6887* (holotype, BR!; isotypes, B!, BR!, C!, COI!, EA!, HBG!, K!, MO!, P!, PRE!, UPS!, WAG!).
- 3. *Empogona africana*** (Sim) J. Tosh & Robbr., comb. nov. Basionym: *Diplospora africana* Sim, Forest Fl. Cape, 238. 1907. *Tricalysia africana* (Sim) Robbr., S. African J. Bot. 51: 331. 1985. TYPE: South Africa. E Pondoland, Egossa Forest, Aug. 1899, *T. R. Sim 2386* (holotype, NU!).
- 4. *Empogona aulacosperma*** (Robbr.) J. Tosh & Robbr., comb. nov. Basionym: *Tricalysia aulacosperma* Robbr., Bull. Jard. Bot. Natl. Belg. 49: 296. 1979. TYPE: [Democratic Republic of the Congo.] Congo belge. Musenge, 20 Dec. 1958, *A. Léonard 2088* (holotype, BR!; isotypes, EA!, K!, MO!, WAG!).
- (*) **5. *Empogona bequaertii*** (De Wild.) J. Tosh & Robbr., comb. nov. Basionym: *Tricalysia bequaertii* De Wild., Pl. Bequaert. 3: 157. 1925. TYPE: [Democratic Republic of the Congo.] Congo belge. [Kisangani] Stanleyville, Tshopo River, 25 Feb. 1915, *J. Bequaert 6969* (holotype, BR!).
- 6. *Empogona bracteata*** (Hiern) J. Tosh & Robbr., comb. nov. Basionym: *Tricalysia bracteata* Hiern, Fl. Trop. Afr. [Oliver et al.] 3: 120. 1877. TYPE: [Guinea.] Senegambia. Karkandy, s.d., *Heudelot 855* (holotype, K!).
- 7. *Empogona breteleri*** (Robbr.) J. Tosh & Robbr., comb. nov. Basionym: *Tricalysia breteleri* Robbr., Bull. Jard. Bot. Natl. Belg. 51: 166. 1981. TYPE: Gabon. Moanda–Franceville Km 23, 12 Sep. 1970, *F. J. Breteler 6431* (holotype, WAG!; isotypes, BR!, P!).
- 8. *Empogona buxifolia*** (Hiern) J. Tosh & Robbr.
- 8a. *Empogona buxifolia*** (Hiern) J. Tosh & Robbr. subsp. ***buxifolia***, comb. nov. Basionym: *Tricalysia buxifolia* Hiern, Fl. Trop. Afr. [Oliver et al.] 3: 119. 1877. TYPE: Angola. Ambriz, Nov. 1872, *J. Monteiro s.n.* (holotype, K!; isotype, W!).
- 8b. *Empogona buxifolia*** subsp. ***australis*** (Robbr.) J. Tosh & Robbr., comb. et stat. nov. Basionym: *Tricalysia buxifolia* var. *australis* Robbr., Bull. Jard. Bot. Natl. Belg. 48: 465. 1978. TYPE: Angola. Tchivinguiro, 13 Dec. 1961, *G. Barbosa 9650* (holotype, LISC!; isotypes, COI!, K!, LUAI!).
- (*) **9. *Empogona caccondensis*** (Hiern) J. Tosh & Robbr., comb. nov. Basionym: *Tricalysia caccondensis* Hiern, Cat. Afr. Pl. (Hiern) 1(2): 467. 1898. TYPE: Angola. Rd. from Quipaca to fortress near Ferão, Oct. 1859, *F. Welwitsch 3112* (lectotype, designated by Robbrecht [1979: 320], LISU!; duplicates, BM!, COI!, K!).
- (*) **10. *Empogona concolor*** (N. Hallé) J. Tosh & Robbr., comb. nov. Basionym: *Tricalysia concolor* N. Hallé, Fl. Gabon 17: 283. 1970. TYPE: Gabon. Bélinga, mine de fer, 21 July 1966, *N. Hallé & A. Le Thomas 119* (holotype, P!; isotypes, K!, P!).
- 11. *Empogona coriacea*** (Sond.) J. Tosh & Robbr., comb. nov. Basionym: *Kraussia coriacea* Sond., Linnaea 23: 54. 1850. *Tricalysia sonderiana* Hiern, Fl. Trop. Afr. [Oliver et al.] 3: 119. 1877, replacement for *Kraussia coriacea* Sond., non *Randia coriacea* Benth., Niger Fl. [W. J. Hooker] 387. 1849 [– *Tricalysia coriacea* (Benth.) Hiern]. TYPE: [South Africa. KwaZulu-Natal:] Natal: Durban, s.d., *W. Gueinzius 100* (holotype, W!; isotypes, BM!, C!, K!, PRE!, S!).
- 12. *Empogona crepiniana*** (De Wild. & T. Durand) J. Tosh & Robbr., comb. nov. Basionym: *Tricalysia crepiniana* De Wild. & T. Durand, Ann. Mus. Congo Belg., Bot. ser. 3, 1: 120. 1901. TYPE: [Democratic Republic of the Congo.] Wangata, 17 Feb. 1896, *A. Dewèvre 740* (holotype, BR!; isotype, COI!).
- 13. *Empogona deightonii*** (Brenan) J. Tosh & Robbr., comb. nov. Basionym: *Tricalysia deightonii* Brenan, Kew Bull. 8: 112. 1953. TYPE: Sierra Leone. Jama, 10 Mar. 1948, *F. C. Deighton 4723* (holotype, K!; isotype, P!).
- 14. *Empogona discolor*** (Brenan) J. Tosh & Robbr., comb. nov. Basionym: *Tricalysia discolor* Brenan, Kew Bull. 2: 72. 1947. TYPE: [Ghana.] Gold Coast. Mampong Scarp, Feb. 1933, *C. Vigne 2748* (holotype, K!; isotype, MO!).
- 15. *Empogona filiformistipulata*** (De Wild.) Bremek.
- 15a. *Empogona filiformistipulata*** (De Wild.) Bremek. subsp. ***filiformistipulata***, Bot. Jahrb. 71:

201, 222. 1940. Basionym: *Urophyllum filiformi-stipulatum* De Wild., Pl. Bequaert. 3: 211. 1925. *Tricalysia filiformi-stipulata* (De Wild.) Brenan, Kew Bull. 8: 112. 1953. TYPE: [Democratic Republic of the Congo.] Congo belge. Kisangani, Tshopo River, 12 Jan. 1915, *J. Bequaert 6580* (holotype, BR!; isotype, K not seen).

15b. *Empogona filiformistipulata* subsp. *epipsila* (Robbr.) J. Tosh & Robbr., comb. et stat. nov. Basionym: *Tricalysia filiformistipulata* (De Wild.) Brenan var. *epipsila* Robbr., Bull. Jard. Bot. Natl. Belg. 48: 465. 1978. TYPE: [Democratic Republic of the Congo.] Congo belge. Yangambi, Feb. 1933, *J. Louis 14233* (holotype, BR!; isotypes, COI!, K!, MO!, P!, WAG!).

16. *Empogona glabra* (K. Schum.) J. Tosh & Robbr., comb. nov. Basionym: *Tricalysia glabra* K. Schum., Bot. Jahrb. Syst. 23: 445. 1896. TYPE: Angola. Catete, Nov. 1856, *F. Welwitsch 3117* (holotype, LISU!; isotypes, BM!, C!, COI!, K!, P!).

(*) **17. *Empogona gossweileri*** (S. Moore) J. Tosh & Robbr., comb. nov. Basionym: *Tricalysia gossweileri* S. Moore, J. Linn. Soc. Bot. 37: 305. 1906. TYPE: Angola. Cuanza Norte, Cazengo, 1903, *J. Gossweiler 688* (holotype, BM!; isotypes, K!, P!).

18. *Empogona kirkii* Hook. f.

18a. *Empogona kirkii* Hook. f. subsp. *kirkii*, Hooker's Icon. Pl. 11: 72, t. 1091. 1871. *Tricalysia junodii* (Schinz) Brenan var. *kirkii* (Hook. f.) Robbr., Bull. Jard. Bot. Natl. Belg. 49: 271. 1979. TYPE: Malawi. Cape Maclear, Oct. 1861, *J. Kirk s.n.* (holotype, K!).

Empogona allenii Stapf is the only species validly published in the genus *Empogona* not taken up as a result of the present study. It is a synonym of the present taxon (Robbrecht, 1979: 272).

(*) **18b. *Empogona kirkii* subsp. *junodii*** (Schinz) J. Tosh & Robbr., comb. et stat. nov. Basionym: *Empogona junodii* Schinz, Mém. Herb. Boiss. 10: 67. 1900. *Tricalysia junodii* (Schinz) Brenan, Kew Bull. 2: 60. 1947. TYPE: Mozambique. Baia de Laurenço Marques (Delagoa Bay), s.d., *H. Junod 311* (holotype, Z!).

(*) **19. *Empogona lanceolata*** (Sond.) J. Tosh & Robbr., comb. nov. Basionym: *Kraussia lanceolata* Sond., Linnaea 23: 53. 1850. *Tricalysia lanceolata* (Sond.) Burt Davy, Ann. Transvaal

Mus. 3: 122. 1912. TYPE: [South Africa. KwaZulu-Natal:] Natal: Durban, *W. Gueinzius 68* (lectotype, designated by Robbrecht [1979: 313], W!; duplicates, P!, S!).

20. *Empogona macrophylla* (K. Schum.) J. Tosh & Robbr., comb. nov. Basionym: *Tricalysia macrophylla* K. Schum., Bot. Jahrb. Syst. 28: 66. 1899. TYPE: Cameroon. Bipinde, *Zenker 1569* (lectotype, designated by Robbrecht [1979: 339], COI!; duplicates, BM!, BR!, COI!, E!, G!, GOET!, HBG!, L!, M!, MO!, P!, S!, W!, WAG!).

21. *Empogona maputenis* (Bridson & A. E. van Wyk) J. Tosh & Robbr., comb. nov. Basionym: *Tricalysia maputensis* Bridson & A. E. van Wyk, Fl. Zambes. 5(3): 475. 2003. TYPE: Mozambique. Matutuine, 8 Aug. 1957, *L. A. G. Barbosa & F. L. de Lemos 7807* (holotype, LISC not seen).

(*) **22. *Empogona ngalaensis*** (Robbr.) J. Tosh & Robbr., comb. nov. Basionym: *Tricalysia ngalaensis* Robbr., Bull. Jard. Bot. Natl. Belg. 49: 277. 1979. TYPE: Malawi. North Ngala, 20 mi. N of Chilumba, 17 Dec. 1969, *J. Pawek 3095* (holotype, K!).

23. *Empogona nogueirae* (Robbr.) J. Tosh & Robbr., comb. nov. Basionym: *Tricalysia nogueirae* Robbr., Bull. Jard. Bot. Natl. Belg. 48: 466. 1978. TYPE: Angola. Musenge, 14 Oct. 1966, *J. B. Teixeira 10701* (holotype, LISC!; isotype, COI!).

24. *Empogona ovalifolia* (Hiern) J. Tosh & Robbr.

(*) **24a. *Empogona ovalifolia*** (Hiern) J. Tosh & Robbr. var. *ovalifolia*, comb. nov. Basionym: *Tricalysia ovalifolia* Hiern, Fl. Trop. Afr. [Oliver et al.] 3: 119. 1877. TYPE: [Tanzania.] Zanzibar: s. loc., s.d. [acc. K Sep. 1868], *J. Kirk s.n.* (lectotype, designated by Robbrecht [1979: 339], K!).

24b. *Empogona ovalifolia* var. *glabrata* (Oliv.) J. Tosh & Robbr., comb. nov. Basionym: *Empogona kirkii* Hook. f. var. *glabrata* Oliv., Trans. Linn. Soc., Bot., 2: 336. 1887. *Tricalysia ovalifolia* Hiern var. *glabrata* (Oliv.) Brenan, Kew Bull. 2: 58. 1947. TYPE: Kenya or Tanzania. 40–60 mi. from coast, [1884], *H. H. Johnston s.n.* [Kilimanjaro Exp.] (holotype, K!).

24c. *Empogona ovalifolia* var. *taylorii* (S. Moore) J. Tosh & Robbr., comb. nov. Basionym: *Empogona taylorii* S. Moore, J. Bot. 63: 145. 1925. *Tricalysia ovalifolia* Hiern var. *taylorii* (S.

Moore) Brenan, Kew Bull. 2: 59. 1947. TYPE: Kenya. Giriama, Oct. 1887, *W. E. Taylor s.n.* (holotype, BM!).

25. *Empogona reflexa* (Hutch.) J. Tosh & Robbr.

25a. *Empogona reflexa* (Hutch.) J. Tosh & Robbr. var. **reflexa**, comb. nov. Basionym: *Tricalysia reflexa* Hutch., Kew Bull. 1915: 44. 1915. TYPE: Sierra Leone. Kessewe, 17 Apr. 1913, *C. E. Lane-Poole 131* (holotype, K!).

25b. *Empogona reflexa* var. *ivorensis* (Robbr.) J. Tosh & Robbr., comb. nov. Basionym: *Tricalysia reflexa* var. *ivorensis* Robbr., Bull. Jard. Bot. Natl. Belg. 48: 466. 1978. TYPE: Ivory Coast. W of Niapidou, 20 Jan. 1959, *A. J. M. Leeuwenberg 2500* (holotype, WAG!; isotypes, BR!, K!).

(* **26. *Empogona ruandensis* (Bremek.) J. Tosh & Robbr.**, comb. nov. Basionym: *Tricalysia ruandensis* Bremek., Bull. Jard. Bot. État Bruxelles 26: 253. 1956. TYPE: [Rwanda.] Mayaga, Mutema, 19 May 1954, *L. Liben 1416* (holotype, U!; isotypes, BR!, WAG!).

27. *Empogona somaliensis* (Robbr.) J. Tosh & Robbr., comb. nov. Basionym: *Tricalysia somaliensis* Robbr., Bull. Jard. Bot. Natl. Belg. 56: 149. 1986. TYPE: Somalia. 17 km W of Badade, 30 June 1983, *J. B. Gillett, C. F. Hemming, R. M. Watson & H. Julin 25153* (holotype, K!).

(* **28. *Empogona talbotii* (Wernham) J. Tosh & Robbr.**, comb. nov. Basionym: *Cremaspora talbotii* Wernham, Cat. Pl. Oban 49. 1913. *Tricalysia talbotii* (Wernham) Keay, Bull. Jard. Bot. État Bruxelles 28: 291. 1958. TYPE: Nigeria. Southern Nigeria, Oban, 1911, *P. A. Talbot 287* (holotype, BM!; isotype, K!).

29. *Empogona welwitschii* (K. Schum.) J. Tosh & Robbr., comb. nov. Basionym: *Tricalysia welwitschii* K. Schum., Bot. Jahrb. Syst. 23: 449. 1897. TYPE: Angola. Near Ponte do Felix Simões, Apr. 1855, *F. Welwitsch 3106* (holotype, LISU!; duplicates, BM not seen, COI!, K!, P!).

CONCLUSIONS AND FUTURE DIRECTIONS

We have been able to demonstrate that the two subgenera comprising the large Afro-Malagasy genus *Tricalysia* do not form a monophyletic group and should be treated as separate genera. *Empogona* has been previously recognized at generic rank, and

subsequent authors have considered reviving its generic status. On the basis of our molecular evidence, it is now fully justified to revive *Empogona* at the generic rank. The Asian genus *Diplospora* is sister to *Empogona*, with both genera forming a strongly supported monophyletic group. As a consequence, the weakly supported Asian clade reported by Davis et al. (2007) is not recovered in this investigation. Further data are still required to fully elucidate the phylogenetic relationships between *Belonophora*, *Diplospora*, *Discospermum*, *Empogona*, *Sericanthe*, and *Tricalysia*. There is increased support for the placement of a *Coffea* and *Psilanthus* clade as sister to the rest of Coffeae.

Future work requires the inclusion of nuclear ribosomal and low copy nuclear DNA sequence data, as well as expanded taxon sampling, in an effort to improve resolution between terminal taxa within the genera *Tricalysia* and *Empogona*. It seems prudent to defer detailed discussion on the biogeography of *Tricalysia* and *Empogona* until we have a broader sampling and a more resolved phylogenetic hypothesis of both genera.

Literature Cited

- Ali, S. J. & E. Robbrecht. 1991. Remarks on the tropical Asian and Australian taxa included in *Diplospora* or *Tricalysia* (Rubiaceae-Ixoroideae-Gardenieae). *Blumea* 35: 279–305.
- Andreasen, K. & B. Bremer. 2000. Combined phylogenetic analysis in the Rubiaceae-Ixoroideae: Morphology, nuclear and chloroplast DNA data. *Amer. J. Bot.* 87: 1731–1748.
- Brenan, J. P. M. 1947. *Empogona* Hook. f. and its relation to *Tricalysia* DC. *Kew Bull.* 1947: 53–63.
- Bridson, D. M. & B. Verdcourt. 2003. Rubiaceae. Pp. 379–720 in G. V. Pope (editor), *Flora Zambesiaca*, Vol. 5(3). Royal Botanic Gardens, Kew.
- Cheek, M. & S. Dawson. 2000. A synoptic revision of *Belonophora* (Rubiaceae). *Kew Bull.* 55: 63–80.
- Davis, A. P., M. Chester, O. Maurin & M. Fay. 2007. Searching for the relatives of *Coffea* (Rubiaceae, Ixoroideae): The circumscription and phylogeny of Coffeae based on plastid sequence data and morphology. *Amer. J. Bot.* 94: 313–329.
- Doyle, J. J. & J. L. Doyle. 1987. A rapid DNA isolation procedure for small quantities of fresh leaf tissue. *Phytochem. Bull.* 19: 11–15.
- Erixon, P., B. Sennblad, T. Britton & B. Oxelman. 2003. Reliability of Bayesian posterior probabilities and bootstrap frequencies in phylogenetics. *Syst. Biol.* 52: 665–673.
- Felsenstein, J. 1985. Phylogenies and the comparative method. *Amer. Naturalist* 125: 1–15.
- Hooker, J. D. 1873. Rubiaceae. Pp. 7–151 in G. Bentham & J. D. Hooker (editors), *Genera Plantarum*, Vol. 2(1). Lovell Reeve & Co., London.
- Huelsenbeck, J. P. & F. Ronquist. 2001. MRBAYES. Bayesian inference of phylogeny. *Bioinformatics* 17: 754–755.
- , B. Larget, R. E. Miller & F. Ronquist. 2002. Potential applications and pitfalls of Bayesian inference of phylogeny. *Syst. Biol.* 51: 673–688.

- Jordan, W. C., M. W. Courtney & J. E. Neigel. 1996. Low levels of interspecific genetic variation at a rapidly evolving chloroplast DNA locus in North American duckweed (Lemnaceae). *Amer. J. Bot.* 83: 430–439.
- Keay, R. W. J. 1958. Notes on Rubiaceae for the Flora of West Tropical Africa, 2nd ed. *Bull. Jard. Bot. État.* 28: 297–298.
- Löhne, C. & T. Borsch. 2005. Molecular evolution and phylogenetic utility of the petD group II intron: A case study in basal angiosperms. *Molec. Biol. Evol.* 22: 317–332.
- Maddison, D. R. & W. P. Maddison. 2002. *MacClade 4: Analysis of phylogeny and character evolution*, version 4.01. Sinauer Associates, Sunderland, Massachusetts.
- Mendenhall, M. 1994. Phylogeny of *Baptista* and *Thermopsis* (Leguminosae) as Inferred from Chloroplast DNA and Nuclear Ribosomal DNA Sequences, Secondary Chemistry, and Morphology. Ph.D. Dissertation, University of Texas, Austin.
- Persson, C. 2000. Phylogeny of Gardenieae (Rubiaceae) based on chloroplast DNA sequences from the *rps16* intron and *trnL(UAA)-F(GAA)* intergenic spacer. *Nord. J. Bot.* 20: 257–270.
- Posada, D. & K. A. Crandall. 1998. Modeltest: Testing the model of DNA substitution. *Bioinformatics* 14: 817–818.
- Ranarivelo-Randriamboavonjy, T., E. Robbrecht, E. Rabakonandrianina & P. De Block. 2007. Revision of the Malagasy species of the genus *Tricalysia* (Rubiaceae). *Bot. J. Linn. Soc.* 155: 83–126.
- Randle, C. P., M. E. Mort & D. J. Crawford. 2005. Bayesian inference of phylogenetics revisited: Developments and concerns. *Taxon* 54: 9–15.
- Robbrecht, E. 1978. *Sericanthe*, a new African genus of Rubiaceae (Coffeae). *Bull. Jard. Bot. Natl. Belg.* 48: 3–78.
- . 1979. The African genus *Tricalysia* A. Rich. (Rubiaceae-Coffeae). 1. A revision of the species of subgenus *Empogona*. *Bull. Jard. Bot. Natl. Belg.* 49: 239–360.
- . 1982. The African genus *Tricalysia* A. Rich. (Rubiaceae-Coffeae). 2. *Ephedranthera*, a new section of subgenus *Tricalysia*. *Bull. Jard. Bot. Natl. Belg.* 52: 311–339.
- . 1983. The African genus *Tricalysia* A. Rich. (Rubiaceae). 3. *Probletostemon* revived as a section of subgenus *Tricalysia*. *Bull. Jard. Bot. Natl. Belg.* 53: 299–320.
- . 1987. The African genus *Tricalysia* A. Rich. (Rubiaceae). 4. A revision of the species of section *Tricalysia* and section *Rosea*. *Bull. Jard. Bot. Natl. Belg.* 57: 39–208.
- . 1988. Tropical woody Rubiaceae. *Opera Bot. Belg.* 1: 1–271.
- & C. Puff. 1986. A survey of the Gardenieae and related tribes (Rubiaceae). *Bot. Jahrb. Syst.* 108: 63–137.
- & J.-F. Manen. 2006. The major evolutionary lineages of the coffee family (Rubiaceae, angiosperms). Combined analysis (nDNA and cpDNA) to infer the position of *Coptosapelta* and *Luculia*, and supertree construction based on *rbcL*, *rps16*, *trnL-trnF* and *aptB-rbcL* data. A new classification in two subfamilies, Cinchonoideae and Rubioideae. *Syst. & Geogr. Pl.* 76: 85–146.
- Ronquist, F., J. P. Huelsenbeck & P. van der Mark. 2005. MrBayes 3.1 manual. <http://mrbayes.csit.fsu.edu/mb3.1_manual.pdf>, accessed 30 October 2008.
- Schumann, K. 1891. Rubiaceae. Pp. 1–156 in A. Engler & K. Prantl (editors), *Die natürlichen Pflanzenfamilien*, Vol. 4 (4). Wilhelm Engelmann Verlag, Leipzig.
- Shaw, J., E. B. Licky, J. T. Beck, S. B. Farmer, W. Liu, J. Miller, K. C. Siripun, C. T. Winder, E. E. Schilling & R. L. Small. 2005. The tortoise and the hare II: Relative utility of 21 noncoding chloroplast DNA sequences for phylogenetic analysis. *Amer. J. Bot.* 92: 142–166.
- Simmons, M. P. & H. Ochoterena. 2000. Gaps as characters in sequence-based phylogenetic analysis. *Syst. Biol.* 49: 369–381.
- Stace, C. A. 1991. *Plant Taxonomy and Biosystematics*, 2nd ed. Edward Arnold, London.
- Staden, R., K. Beal & J. Bonfield. 1998. The Staden Package. Pp. 115–130 in S. Misener & S. Krawetz (editors), *Computer Methods in Molecular Biology*. Humana Press, New York.
- Swofford, D. L. 2003. PAUP* 4.0b10: Phylogenetic Analysis Using Parsimony (* and other methods). Sinauer Associates, Sunderland, Massachusetts.
- Taberlet, P., L. Gielly, G. Pautou & J. Bovet. 1991. Universal primers for amplification of three non-coding regions of chloroplast DNA. *Pl. Molec. Biol.* 17: 1005–1109.

Appendix 1. Taxon voucher and accession data.

Taxon	Voucher	<i>accD-psal</i>	<i>petD</i>	<i>rpl16</i>	<i>trnL-F</i>
<i>Argocoffeopsis eketensis</i> (Wernham) Robbr.	Davis 3031 (K), Cameroon	DQ180497	AM999399	DQ180531	DQ180566
<i>Argocoffeopsis rupestris</i> (Hiern) Robbr. subsp. <i>thonneri</i> (Lebrun) Robbr.	Harris 8168 (K), Central African Republic	DQ180496	NA	DQ180532	DQ180567
<i>Argocoffeopsis scandens</i> (K. Schum.) Lebrun	Davis 3016 (K), Cameroon	DQ180498	AM999400	DQ180533	DQ180568
<i>Belonophora coriacea</i> Hoyle	Maurin 5 (K), Cameroon	DQ180499	AM999401	DQ180534	DQ180569
<i>Belonophora coriacea</i> Hoyle	Maurin 19 (K), Cameroon	DQ180500	AM999402	DQ180535	DQ180570
<i>Belonophora</i> sp. indet.	Tadjouteu 480 (K), Cameroon	DQ180501	AM999403	DQ180536	DQ180571
<i>Bertiera bicarpellata</i> (K. Schum.) N. Hallé	Davis 3051 (K), Cameroon	DQ180502	AM999396	DQ180537	DQ180572
<i>Bertiera brevipflora</i> Hiern	Van Caekenberghe 41 (BR), Gabon*	NA	AM999397	AM999524	AM999466
<i>Bertiera iturensis</i> K. Krause	Van Caekenberghe 40 (BR), Gabon*	FM160622	AM999398	AM999525	AM999467
<i>Bertiera</i> sp. indet.	Davis 3017 (K), Cameroon	DQ180504	NA	DQ180539	DQ180574
<i>Calycosiphonia macrochlamys</i> (K. Schum.) Robbr.	Davis 3044 (K), Cameroon	DQ180507	NA	DQ180542	DQ180576
<i>Calycosiphonia macrochlamys</i> (K. Schum.) Robbr.	Davis 3036 (K), Cameroon	DQ180506	AM999404	DQ180541	DQ180575
<i>Calycosiphonia spathicalyx</i> (K. Schum.) Robbr.	Davis 2925 (K), Tanzania	DQ180509	AM999405	DQ180544	DQ180578
<i>Canephora</i> sp. indet.	Davis 2727 (K), Madagascar	DQ180510	NA	AM999523	DQ180579
<i>Coffea homollei</i> J.-F. Leroy	Davis 2305 (K), Madagascar	DQ153402	NA	DQ153651	DQ153769
<i>Coffea mangoroensis</i> Portères	Rakotonasolo 41 (K), Madagascar	DQ153503	AM999406	DQ153752	DQ153870
<i>Coffea moratii</i> J.-F. Leroy ex A. P. Davis & Rakotonas.	Davis 2326 (K), Madagascar	DQ153502	AM999407	DQ153751	DQ153869
<i>Didymosalpinx norae</i> (Swynn.) Keay	Van Caekenberghe 62 (BR), Zimbabwe*	FM160621	AM999395	AM999522	AM999465
<i>Diplospora dubia</i> (Lindl.) Masam.	Van Caekenberghe 49 (BR) ^a	AM999388	AM999408	AM999526	AM999468
<i>Diplospora</i> sp. indet.	Bremer 15238 (K), Borneo (Brunei)	DQ180511	NA	DQ180546	DQ180580
<i>Diplospora</i> sp. indet.	Nangkat 15238 (K), Borneo (Brunei)	AM999389	AM999409	AM999527	AM999510
<i>Discospermum abnorme</i> (Korth.) S. J. Ali & Robbr.	Sidiyasa 2148 (K), Borneo (Kalimantan)	AM999380	AM999410	AM999528	AM999469
<i>Discospermum</i> sp. indet.	Ismail 16846 (K), Borneo (Brunei)	AM999390	AM999411	AM999529	AM999470
<i>Doricera trilocularis</i> (Balf. f.) Verdc.	Friedmann 2939 (K), Mascarenes (Rodrigues)	DQ180513	NA	DQ180548	DQ180582
<i>Gardenia thunbergia</i> L. f.	Davis et al. 1961-29703 (K), SE Africa	DQ180514	NA	DQ180549	DQ180583
<i>Hyperacanthus microphyllus</i> (K. Schum.) Bridson	Goyder 5024 (K), Madagascar	AM999387	NA	AM999520	AM999464
<i>Hyperacanthus perrieri</i> (Drake) Rakotonas. & A. P. Davis	Davis 2584 (K), Madagascar	FM160619	NA	AM999519	AM999462
<i>Hyperacanthus</i> sp. indet.	Davis 2586 (K), Madagascar	FM160620	NA	AM999521	AM999463
<i>Ixora guillotii</i> Hochr.	Tosh et al. 408B (BR), Madagascar	FM160624	AM999394	AM999518	AM999461
<i>Psilanthus ebracteolatus</i> Hiern	Billiet 53054 (BR), Ivory Coast*	AM999392	AM999412	AM999530	AM999471
<i>Psilanthus mannii</i> Hook. f.	Van Caekenberghe 78 (BR), Ghana*	FM160623	AM999413	AM999531	AM999472
<i>Psilanthus semsei</i> Bridson	Kisera 1473 (K), Tanzania	DQ153395	AM999414	DQ153644	DQ153762
<i>Polysphaeria</i> sp. indet.	Mvungi 15 (K), Tanzania	DQ180517	NA	DQ180552	DQ180586
<i>Sericanthe andogensis</i> (Hiern) Robbr.	Bidgood 3490 (K), Tanzania	DQ180522	AM999416	DQ180557	DQ180591
<i>Sericanthe andogensis</i> (Hiern) Robbr.	Dessein 1097 (BR), Zambia	FM177157	AM999415	AM999532	AM999473

Appendix 1. Continued.

Taxon	Voucher	<i>accD-psaI</i>	<i>petD</i>	<i>rpl16</i>	<i>trnL-F</i>
<i>Sericanthe jacfelictis</i> (N. Hallé) Robbr.	<i>Carvalho 4169</i> (K), Gulf of Guinea Islands (Bioko)	DQ180523	NA	NA	DQ180592
<i>Sericanthe</i> sp. indet.	<i>Valkenberg 3160</i> (WAG), Gabon	AM999391	AM999417	AM999533	AM999511
<i>Tricalysia aciculiflora</i> Robbr.	<i>Manktelow 91215</i> (K), Tanzania	AM999345	AM999419	AM999535	AM999475
<i>Tricalysia aciculiflora</i> Robbr.	<i>Luke 7071</i> (K), Tanzania	AM999344	AM999418	AM999534	AM999474
<i>Tricalysia acidophylla</i> Robbr.	<i>Kindekat 122</i> (BR), Tanzania	AM999346	AM999420	AM999536	AM999512
<i>Tricalysia acocantheroides</i> K. Schum.	<i>Dessein 1212</i> (BR), Zambia	AM999347	AM999421	AM999537	AM999476
<i>Tricalysia acocantheroides</i> K. Schum.	<i>Brummit 320</i> (K), Malawi	AM999348	AM999422	FM160581	AM999513
<i>Tricalysia ambrensis</i> Randriamb. & De Block	<i>De Block 1313</i> (BR), Madagascar	AM999349	AM999423	FM160582	AM999477
<i>Tricalysia analamazaotrensis</i> Homolle ex Randriamb. & De Block	<i>Tosh et al. 11</i> (BR), Madagascar	AM999350	AM999424	FM160583	AM999478
<i>Tricalysia analamazaotrensis</i> Homolle ex Randriamb. & De Block	<i>De Block et al. 1874</i> (BR), Madagascar	AM999351	AM999425	FM160584	AM999514
<i>Tricalysia anomala</i> E. A. Bruce var. <i>guineensis</i> Robbr.	<i>Davis 3045</i> (K), Cameroon	DQ180526	AM999426	DQ180560	DQ180595
<i>Tricalysia bagshawei</i> S. Moore	<i>Malaisse 2052</i> (K), Democratic Republic of the Congo	AM999352	AM999427	FM160585	AM999479
<i>Tricalysia bequaertii</i> De Wild.	<i>Walters 942</i> (MO), Gabon	AM999353	AM999428	FM160586	AM999480
<i>Tricalysia bridsoniana</i> Robbr.	<i>De Block 389</i> (BR), Kenya	AM999354	AM999429	FM160587	AM999481
<i>Tricalysia cacondensis</i> Hiern	<i>Dessein 1031</i> (BR), Zambia	AM999355	AM999430	FM160588	AM999482
<i>Tricalysia concolor</i> N. Hallé	<i>Degreef 95</i> (BR), Gabon	AM999356	AM999431	FM160589	AM999483
<i>Tricalysia coriacea</i> (Benth.) Hiern	<i>Dessein 1283</i> (BR), Zambia	AM999358	AM999433	FM160591	AM999485
<i>Tricalysia coriacea</i> (Benth.) Hiern	<i>Dessein 1359</i> (BR), Zambia	AM999357	AM999432	FM160590	AM999484
<i>Tricalysia cryptocalyx</i> Baker	<i>De Block 527</i> (BR), Madagascar	AM999359	AM999434	FM160592	AM999486
<i>Tricalysia cryptocalyx</i> Baker	<i>Tosh et al. 322</i> (BR), Madagascar	AM999360	AM999435	FM160593	AM999487
<i>Tricalysia dauphinensis</i> Randriamb. & De Block	<i>De Block 694</i> (BR), Madagascar	AM999361	AM999436	FM160594	AM999488
<i>Tricalysia dauphinensis</i> Randriamb. & De Block	<i>Tosh et al. 349</i> (BR), Madagascar	AM999362	AM999436	FM160595	AM999489
<i>Tricalysia dauphinensis</i> Randriamb. & De Block	<i>Rabohitra 2115</i> (K), Madagascar	AM999363	AM999438	FM160596	AM999490
<i>Tricalysia elliottii</i> (K. Schum.) Hutch. & Dalziel	<i>Jongkind 1806</i> (K), Ghana	AM999364	AM999439	FM160597	AM999491
<i>Tricalysia gossweilerii</i> S. Moore	<i>Senterre 4041</i> , Equatorial Guinea	AM999365	AM999440	FM160598	AM999492
<i>Tricalysia griseiflora</i> K. Schum.	<i>Dessein 1044</i> (BR), Zambia	AM999367	AM999442	FM160600	AM999494
<i>Tricalysia griseiflora</i> K. Schum.	<i>Dessein 305</i> (BR), Zambia	AM999366	AM999441	FM160599	AM999493
<i>Tricalysia jasminiflora</i> (Klotzsch) Benth. & Hook. f. ex Hiern	<i>Ayami 42</i> (K), Malawi	AM999368	AM999443	FM160601	AM999495
<i>Tricalysia junodii</i> (Schinz) Brenan	<i>Van Caekenberghe 79</i> (BR), Zimbabwe*	AM999369	AM999444	FM160602	AM999496
<i>Tricalysia lanceolata</i> (Sond.) Burt Davy	<i>Bagliss 1519</i> (K), South Africa	AM999370	AM999445	FM160603	AM999497
<i>Tricalysia leucocarpa</i> (Baill.) Randriamb. & De Block	<i>Gautier 2442</i> (K), Madagascar	AM999371	AM999446	FM160604	AM999498
<i>Tricalysia leucocarpa</i> (Baill.) Randriamb. & De Block	<i>Tosh et al. 398</i> (BR), Madagascar	AM999372	AM999447	FM160605	AM999499
<i>Tricalysia microphylla</i> Hiern	<i>De Block 405</i> (BR), Kenya	AM999373	AM999448	FM160606	AM999500
<i>Tricalysia ngalaensis</i> Robbr.	<i>Bidgood 2966</i> (K), Tanzania	AM999374	AM999449	FM160607	AM999501
<i>Tricalysia okelensis</i> Hiern	<i>Schmidt 2139</i> (K), Ghana	AM999375	AM999450	FM160608	AM999505

Appendix 1. Continued.

Taxon	Voucher	<i>accD-psaI</i>	<i>petD</i>	<i>rpl16</i>	<i>trnL-F</i>
<i>Tricalysia ovalifolia</i> Hiern	<i>De Block et al. 1072</i> (BR), Madagascar	AM999378	AM999453	FM160611	AM999504
<i>Tricalysia ovalifolia</i> Hiern	<i>De Block et al. 1090</i> (BR), Madagascar	AM999376	AM999452	FM160609	AM999503
<i>Tricalysia ovalifolia</i> Hiern	<i>Butly 309</i> (K), Tanzania	AM999377	AM999451	FM160610	AM999502
<i>Tricalysia pallens</i> Hiern	<i>Dessein 1266</i> (BR), Zambia	AM999381	AM999455	FM160613	AM999515
<i>Tricalysia pallens</i> Hiern	<i>Dessein 953</i> (BR), Zambia	AM999382	AM999456	FM160614	AM999516
<i>Tricalysia pallens</i> Hiern	<i>Adams 831</i> (K), Liberia	AM999379	AM999454	FM160612	AM999506
<i>Tricalysia perrieri</i> Homolle ex Randriamb. & De Block	<i>De Block 766</i> (BR), Madagascar	AM999383	AM999457	FM160615	AM999507
<i>Tricalysia ruandensis</i> Bremek.	<i>Kuchar 22323</i> (BR), Tanzania	AM999384	AM999458	FM160616	AM999517
<i>Tricalysia schliebenii</i> Robbr.	<i>Bidgood 1913</i> (K), Tanzania	AM999385	AM999459	FM160617	AM999508
<i>Tricalysia talbotii</i> (Wernham) Keay	<i>Latilo 67674</i> (K), Nigeria	AM999386	AM999460	FM160618	AM999509

* Leaf material and vouchers collected from the living collections of National Botanic Garden of Belgium. Country of origin given in the table.

^a Origin unknown. Living material given to National Botanic Garden of Belgium by Hong Kong Herbarium.

Acknowledgment of Reviewers

The following individuals are thanked for their collegial reviews in 2008. This peer commitment of time and effort is sincerely appreciated by the *Annals*.

Nélida Bacigalupo
Anders Barfod
Rainer Bussmann
Daniel Cadena
Christopher Campbell
Diane Campbell
Philip Cantino
Steven Clemants
Marshall Crosby
Gerrit Davidse
Michael Dillon
Michele Dudash
Friedrich Ehrendorfer
Peter Endress
Per Ericson
Richard Field
Tarciso Filgueiras
Victor Finot
David Foster
Kanchi Gandhi
Kevin Gaston
Laurent Gautier
Diego Giraldo-Cañas
Liliana Giussani
Socorro González-Elizondo
Alan Graham
Richard Halse
Anna Hersperger
Henry Hooghiemstra
John Janovec
Iván Jiménez
Peter Jørgensen
Walter Judd
Margaret Koopman
John Kress
Kathleen Kron
Gwilym Lewis
Gabriela Lopez
Jon Lovett

Pete Lowry
Martin Lysak
Jinshuang Ma
Vidal de Freitas Mansano
Ligia Matias
Gordon McPherson
Robbin Moran
Tim Motley
Jesús Muñoz
Jens Mutke
Sachiko Nishida
Antony Orme
Kathleen Pigg
Ana María Planchuelo
Nina Probatova
Sylvain Razafimandimbison
Renata Reinheimer
Jon Ricketson
Bob Ricklefs
Pavel O. Rodríguez Vásquez
Zachary Rogers
Jens G. Rohwer
Alicia Rotman
Andrew Rozefelds
Kalle Ruokolainen
Fátima Regina Gonçalves Salimena
Wendy Silk
Peter Stevens
Charlotte Taylor
Hans ter Steege
Mats Thulin
Tim Utteridge
Ricardo Vieira
Michael Vincent
Steven Wagstaff
Richard Weaver
Maximilian Weigend
Peter Wilf
Kenneth Wurdack
George Yatskievych
—*Votis gratias agamus.*

www.mbgpress.org

CONTENTS

Third International Rubiaceae Conference: Introduction		
	<i>Petra De Block, Charlotte M. Taylor & Suzy Huysmans</i>	1
A Review of Molecular Phylogenetic Studies of Rubiaceae	<i>Birgitta Bremer</i>	4
Revisión Sinóptica de <i>Galianthe</i> Subgen. <i>Galianthe</i> (Rubiaceae: Spermacoceae), con una Sección Nueva	<i>Elsa L. Cabral</i>	27
Phylogenetic Placement of the Tribe Retiniphyllae Among the Subfamily Ixoroideae (Rubiaceae)	<i>Rocio Cortés-B., Piero G. Delprete & Timothy J. Motley</i>	61
A Global Assessment of Distribution, Diversity, Endemism, and Taxonomic Effort in Rubiaceae	<i>Aaron P. Davis, Rafaël Govaerts, Diane M. Bridson, Markus Ruhsam, Justin Moat & Neil A. Brummitt</i>	68
Taxonomic History, Morphology, and Reproductive Biology of the Tribe Posoquerieae (Rubiaceae, Ixoroideae)	<i>Piero G. Delprete</i>	79
Fossil Record of the Rubiaceae	<i>Alan Graham</i>	90
Phylogeny of the Herbaceous Tribe Spermacoceae (Rubiaceae) Based on Plastid DNA Data	<i>Inge Groeninckx, Steven Dessen, Helga Ochoterena, Claes Persson, Timothy J. Motley, Jesper Kårehed, Birgitta Bremer, Suzy Huysmans & Erik Smets</i>	109
Foliar and Petiole Anatomy of Tribe Hamelieae and Other Rubiaceae	<i>Dorismilda Martínez-Cabrera, Teresa Terrazas & Helga Ochoterena</i>	133
Paraphyly of <i>Ixora</i> and New Tribal Delimitation of Ixoreae (Rubiaceae): Inference from Combined Chloroplast (<i>rps16</i> , <i>rbcL</i> , <i>trnT-F</i>) Sequence Data	<i>Arnaud Mouly, Sylvain G. Razafimandimbison, Jacques Florence, Joël Jérémie & Birgitta Bremer</i>	146
Evolutionary Trends, Major Lineages, and New Generic Limits in the Dioecious Group of the Tribe Vanguerieae (Rubiaceae): Insights into the Evolution of Functional Dioecy	<i>Sylvain G. Razafimandimbison, Henrik Lantz, Arnaud Mouly & Birgitta Bremer</i>	161
The <i>Rondeletia</i> Complex (Rubiaceae): An Attempt to Use ITS, <i>rps16</i> , and <i>trnL-F</i> Sequence Data to Delimit Guettardeae, Rondeletieae, and Sections Within <i>Rondeletia</i>	<i>Johan H. E. Rova, Piero G. Delprete & Birgitta Bremer</i>	182
Phylogeny of <i>Tricalysia</i> (Rubiaceae) and Its Relationships with Allied Genera Based on Plastid DNA Data: Resurrection of the Genus <i>Empogona</i>	<i>James Tosh, Aaron P. Davis, Steven Dessen, Petra De Block, Suzy Huysmans, Mike F. Fay, Erik Smets & Elmar Robbrecht</i>	194
Acknowledgment of Reviewers		214

Cover illustration. *Galianthe longifolia* (Standl.) E. L. Cabral, drawn by Laura Simón.

Annals
of the
Missouri
Botanical
Garden
2009



Volume 96
Number 2

The Annals, published quarterly, contains papers, primarily in systematic botany, contributed from the Missouri Botanical Garden, St. Louis. Papers originating outside the Garden will also be accepted. All manuscripts are peer-reviewed by qualified, independent reviewers. Instructions to Authors are printed in the back of the last issue of each volume and are also available online at www.mbgpress.org.

Editorial Committee

Victoria C. Hollowell
Scientific Editor,
Missouri Botanical Garden

Beth Parada
Managing Editor,
Missouri Botanical Garden

Allison M. Brock
Associate Editor,
Missouri Botanical Garden

Tammy Charron
Editorial Assistant,
Missouri Botanical Garden

Cirri Moran
Press Coordinator,
Missouri Botanical Garden

Roy E. Gereau
Latin Editor,
Missouri Botanical Garden

Ihsan A. Al-Shehbaz
Missouri Botanical Garden

Gerrit Davidse
Missouri Botanical Garden

Peter Goldblatt
Missouri Botanical Garden

Gordon McPherson
Missouri Botanical Garden

Charlotte Taylor
Missouri Botanical Garden

Henk van der Werff
Missouri Botanical Garden

For subscription information contact ANNALS OF THE MISSOURI BOTANICAL GARDEN, % Allen Marketing & Management, P.O. Box 1897, Lawrence, KS 66044-8897. Subscription price for 2009 is \$175 per volume U.S., \$185 Canada & Mexico, \$210 all other countries. Four issues per volume. The journal *Novon* is included in the subscription price of the *Annals*.

annals@mobot.org (editorial queries)

<http://www.mbgpress.org>

The *Annals* are abstracted and/or indexed in AGRICOLA (through 1994), APT Online, BIOSIS®, CAB Abstract/Global Health databases, ingenta, ISI® databases, JSTOR, Research Alert®, and Sci Search®.

The full-text of ANNALS OF THE MISSOURI BOTANICAL GARDEN is available online through BioOne™ (<http://www.bioone.org>).

© Missouri Botanical Garden Press 2009

The mission of the Missouri Botanical Garden is to discover and share knowledge about plants and their environment, in order to preserve and enrich life.

© This paper meets the requirements of ANSI/NISO Z39.48-1992 (Permanence of Paper).

Volume 96
Number 2
2009

Annals
of the
Missouri
Botanical
Garden



BIOGEOGRAPHY AND
PHYLOGENY OF *CARDAMINE*
(BRASSICACEAE)¹

Tor Carlsen,² Walter Bleeker,³ Herbert Hurka,³
Reidar Elven,² and Christian Brochmann²

ABSTRACT

The biogeography and phylogeny of *Cardamine* L. were inferred based on sequences of the nuclear ribosomal ITS regions and the plastid *trnL* intron and *trnL-F* spacer regions. This genus is one of the largest and polyploid-rich genera of the Brassicaceae and has its center of diversity in Eurasia. Species were included from all populated continents, representing all sections except two monotypic ones. The results support a hypothesis of recent and rapid speciation in the genus. The traditional sectional classification was not supported. We found evidence for several extremely long-distance dispersal events. Colonization of the Southern Hemisphere and the Arctic has occurred repeatedly; we identified at least three phylogenetically distinct Arctic lineages, two distinct Oceanian lineages, and four distinct South American lineages. Polyploidization has occurred independently many times during the evolution of *Cardamine*. Recent divergence combined with widespread polyploidization offer an explanation for the complex taxonomy of the genus.

Key words: Arctic, biogeography, Brassicaceae, *Cardamine*, phylogeny, polyploidization.

Cardamine L. is a taxonomically complex, cosmopolitan genus with at least 160 to 200 Arctic, alpine, and boreal species, and is one of the most species-rich genera of the Brassicaceae (Sjöstedt, 1975; Hewson, 1982; Al-Shehbaz, 1988; Webb et al., 1988; Al-Shehbaz et al., 2006). The number of species accepted varies considerably among different authors, illustrating the notorious taxonomic complexity of this genus. The center of diversity is clearly situated in Eurasia;

according to conservative estimates (mainly based on Al-Shehbaz, 1988), approximately 95 species are Eurasian (ca. 48 of which are in China and ca. 25 in Europe including the Caucasus). There are 43 species in North and Central America (Al-Shehbaz, pers. comm.), and, of these, at least nine species extend into Arctic areas. There are fewer native species in the Southern Hemisphere: 20 in South America (Al-Shehbaz, pers. comm.), 10 in Australia and New

¹ We thank all institutions and colleagues (cf. Appendix 1) for providing plant material for our study. Some material was obtained via R. Elven's participation in the Tundra Northwest (TNW) 1999 expedition funded by the Polar Research Secretariat at the Royal Swedish Academy of Sciences. We thank V. A. Albert and M. Popp for helpful comments, as well as Victoria C. Hollowell, Ihsan Al-Shehbaz, and two anonymous reviewers for improving this manuscript. This study was funded as part of the Strategic University Programme grant 146515/420 from the Research Council of Norway to C. Brochmann and R. Elven (subprogram Migration and Evolution of Arctic Plants in Response to Quaternary Climate Changes).

² National Centre for Biosystematics, Natural History Museum, University of Oslo, P.O. Box 1172 Blindern, NO-0318 Oslo, Norway. Current address: Microbial Evolution Research Group, Biological Institute, University of Oslo, P.O. Box 1172 Blindern, NO-0316 Oslo, Norway. Author for correspondence: tor.carlsen@bio.uio.no.

³ Department of Systematic Botany, University of Osnabrück, Barbarastr. 11, 49076 Osnabrück, Germany.
doi: 10.3417/2007047

Zealand, four in New Guinea, and three in Africa. Some species are invasive cosmopolitan weeds, such as *C. hirsuta* L., *C. impatiens* L., *C. flexuosa* With., and *C. parviflora* L.

In O. E. Schulz's (1903) monograph of the genus, 116 species were accepted and classified into 12 sections. Schulz (1936) later extended his account to include ca. 130 species in 13 sections (Table 1). Of special interest in a biogeographic context are the three largest sections of *Cardamine*: section *Cardamine* L. (Schulz's *Eucardamine* Godr.), section *Dentaria* L., and section *Cardaminella* Prantl. In Schulz's treatments (1903, 1936), section *Cardamine* includes ca. 74 species, has a global distribution, and encompasses a wide range of morphological variation. His section *Dentaria* contains 16 perennial species from North America and Europe characterized by fleshy creeping rhizomes and typically large, showy flowers. Schulz's section *Cardaminella* has a highly disjunct distribution, including four species from the Arctic (including Beringia), three species from alpine areas in Europe, one species from Japan, and three species from Oceania, all of them small, cold-adapted plants. Also noteworthy are six monotypic sections (Table 1).

Many new species have been described since Schulz's (1903, 1936) revisions, but species delimitation is difficult and the total number of species in *Cardamine* remains controversial. The sectional partitioning of Schulz has been criticized by several authors for overemphasizing a few morphological characters (Al-Shehbaz, 1988; Rashid & Ohba, 1993). Previous studies in *Cardamine* have shown that some of his sections (*Cardamine*, *Dentaria*, *Macrocarpus* O. E. Schulz, *Macrophyllum* O. E. Schulz, and *Papyrophyllum* O. E. Schulz) are not monophyletic (Rashid & Ohba, 1993; Franzke et al., 1998; Sweeney & Price, 2000; Bleeker et al., 2002). Several species groups in *Cardamine* have been studied quite extensively based on molecular as well as cytological and morphological data. The *C. pratensis* L. complex, for example, has a history of recurrent polyploidization events and dispersals over relatively long distances (Marhold & Anceev, 1999; Franzke & Hurka, 2000; Marhold et al., 2002, 2004; Lihova et al., 2004; Marhold & Lihova, 2006). However, no genus-wide molecular analysis of *Cardamine* has been performed so far.

Cardamine is probably a fairly young genus. Molecular data indicate that a clade comprising the genera *Barbarea* W. T. Aiton, *A Armoracia* G. Gaertn., B. Mey. & Scherb., and *Rorippa* Scop. is sister to a *Cardamine*-*Nasturtium* W. T. Aiton clade (Franzke et al., 1998; Yang et al., 1999; Koch et al., 2001). *Rorippa* pollen is first found in sediments from the Pliocene (2.5–5 Ma) (Mai, 1995). Koch et al. (2000) used this time span to estimate that the lineages that

gave rise to *Cardamine* and *Barbarea* diverged 6.0 Ma. This was suggested to be an underestimate by Heads (2005), as he doubted the dating of the pollen. However, using the nuclear data set of Koch et al. (2000), Haubold and Wiehe (2001) performed a more thorough study under various evolutionary rate assumptions, all resulting in a divergence time of 6.2 Ma.

Most species of *Cardamine* are polyploid, and up to five basic chromosome numbers have been suggested (Al-Shehbaz, 1988). The most probable basic number for the majority of species is $x = 8$ (Kucera et al., 2005). For some species, such as the Beringian taxa in section *Cardaminella*, the most probable basic number is $x = 7$ (Elven et al., 2006). Diploids are only known with $2n = 16$, and the highest recorded number is $2n = 32x = 256$ (*C. concatenata* (Michx.) O. Schwartz and *C. diphylla* (Michx.) Alph. Wood; Harriman, 1965; Kucera et al., 2005; Warwick & Al-Shehbaz, 2006).

The seeds of *Cardamine* are ejected by curling of the silique walls, a typical short-distance mode of dispersal (Kimata, 1983). *Cardamine* is nevertheless found on all continents except Antarctica. Under moist conditions, the seeds can become mucilaginous and adhere to animals (Al-Shehbaz, 1988). As the majority of *Cardamine* species occur in moist habitats, this may be a common mode of dispersal, also across vast areas via birds. Dispersal between Eurasia and North America may have occurred stepwise via the Tertiary Beringian land bridge that existed until 5.4–5.5 Ma (Marincovich & Gladenkov, 1999, 2001; Gladenkov et al., 2002), but dispersal over longer distances must have occurred between these *Cardamine*-rich continents and Oceania, South America, and Africa.

In this paper, we particularly address the occurrence of such long-distance colonization events, including the colonization of the biogeographically young Arctic region. Among the ca. nine species of *Cardamine* occurring in the Arctic, two (*C. bellidifolia* L. and *C. pratensis* s.l.) have complete circumpolar distributions, and seven are restricted to the Beringian region (*C. blaisdellii* Eastw., *C. digitata* Richardson, *C. purpurea* Cham. & Schldl., *C. pedata* Regel & Tiling, *C. microphylla* Adams, *C. victoris* N. Busch, and *C. sphenophylla* Jurtzev). The current Arctic tundra replaced a more or less continuous forest following the climatic shift in the late Tertiary (Lafontaine & Wood, 1988; Bennike & Böcher, 1990; Matthews & Oviden, 1990; Murray, 1995; Lear et al., 2000). Murray (1995) suggested that the Arctic flora of today is composed of a mixture of survivors from the Arctic Tertiary forest, Pleistocene immigrants from various mountain areas, and in situ-evolved Pleistocene taxa.

Here we attempt to reconstruct the phylogeny of *Cardamine* based on extensive, genus-wide species sampling and sequencing of several DNA regions (using the nuclear ribosomal ITS regions and the plastid *trnL* intron and *trnL-F* spacer regions in the final analysis). In particular, we address the infrageneric classification of *Cardamine*, especially in light of Schulz (1903, 1936), and what is already known from Franzke et al. (1998), Sweeney and Price (2000), and Bleeker et al. (2002). We also examine biogeographic patterns in this widespread genus, and particularly address dispersals and source areas for colonization of the Arctic and Southern Hemisphere.

MATERIALS AND METHODS

Fresh leaf material was sampled and dried in silica gel in the field. Vouchers are deposited in the herbaria at the Natural History Museum, University of Oslo (O), and the University of Osnabrück (OSBU). Leaf material was also sampled from herbarium specimens in ALA, CAN, CANB, DAO, HBG, LE, O, OSBU, OSC, S, UPS, and WU (Appendix 1). Species of *Cardamine* representing all continents where *Cardamine* occurs and 10 of the 13 sections described by Schulz (1903, 1936) were included: exceptions are the monotypic sections *Giraldiella* O. E. Schulz, *Lygophyllum* O. E. Schulz, and *Spiroboles* O. E. Schulz (Table 1).

DNA was extracted using the DNeasy Plant Mini Kit or DNeasy Plant 96 Kit (Qiagen, Hilden, Germany) following the manufacturer's protocol. We initially tested several DNA regions for a subset of species. The mitochondrial *nad6* gene, the nuclear 5S

non-transcribed spacer region, and the plastid regions *trnT-trnL* spacer, *psbA-trnH* spacer, *trnS-trnG* spacer, and *ndhF* gene were tested but found either not variable enough (*nad6*), too variable and difficult to align (the 5S non-transcribed spacer and *psbA-trnH*), or difficult to sequence (*ndhF*, *trnS-trnG*, and *trnT-trnL*). The only useful regions were found to be ITS and the plastid *trnL* intron and *trnL-F* spacer regions.

PCR amplification of ITS was performed with primers ITS-4 and ITS-5 (White et al., 1990) using 30 cycles of 45 sec. at 94°C (first cycle, 5 min.), 45 sec. at 55°C, and 90 sec. at 72°C (last cycle, 10 min.). The *trnL* intron was amplified with the primers c and d, and the *trnL-trnF* intergenic spacer region with the primers e and f (Taberlet et al., 1991) using 30 cycles of 30 sec. at 94°C (first cycle, 5 min.), 30 sec. at 55°C, and 90 sec. at 72°C (last cycle, 10 min.). PCR products were purified with ExoSAP-IT (USB Corporation, Cleveland, Ohio, U.S.A.) before cycle sequencing with BigDye (Applied Biosystems, Foster City, California, U.S.A.) using 25 cycles of 10 sec. at 96°C, 5 sec. at 50°C, and 240 sec. at 60°C.

Sequences were edited in Sequencher 4.1.4 (Gene Codes, Ann Arbor, Michigan, U.S.A.), and ambiguous positions were coded according to the International Union of Pure and Applied Chemistry (IUPAC) standards. Sequences were translated to RNA and analyzed in RNAfold (Hofacker et al., 1994) and MARNA (Siebert & Backofen, 2005) to detect secondary structure and to ensure that conserved stem (helix) regions were aligned correctly. The sequences were subsequently aligned manually in BioEdit (Hall, 1999). The three regions corresponding to the hairpin loop in helix III in ITS-2 and to loops in

Table 1. Sectional classification, geographic distribution, and number of species according to Schulz (1936). The number of species in some of the sections has increased after 1936.

Section	Abbreviation (cf. Fig. 1)	No. of spp.	Geographic distribution
I. <i>Dentaria</i> L.	Dent	16	Eurasia and Atlantic North America
II. <i>Eutreptophyllum</i> O. E. Schulz	Eutr	2	Pacific North America
III. <i>Sphaerotorrhiza</i> O. E. Schulz	Sphae	1	Siberia
IV. <i>Coriophyllum</i> O. E. Schulz	Corio	1	Middle Europe
V. <i>Giraldiella</i> O. E. Schulz ^a	Girar	1	China
VI. <i>Macrophyllum</i> O. E. Schulz	Mac-ph	7	Asia and North America
VII. <i>Lygophyllum</i> O. E. Schulz ^a	Lygo	1	Himalaya
VIII. <i>Papyrophyllum</i> O. E. Schulz	Papyro	8	tropical mountains
IX. <i>Eucardamine</i> Godr. – <i>Cardamine</i> L.	Card	ca. 74	cosmopolitan
X. <i>Cardaminella</i> Prantl	C-nella	12	cold areas all over the world
XI. <i>Pteroneurum</i> (DC.) Nyman	Ptero	5	East Mediterranean region
XII. <i>Spiroboles</i> O. E. Schulz ^a	Spiro	1	Mediterranean region
XIII. <i>Macrocarpus</i> O. E. Schulz	Mac-ca	1	South America

^a Not included in our study.

helices III and IV in ITS-1 could not be unambiguously aligned, and these regions were therefore excluded from the final matrix. For the *trnL-F* spacer region, non-homologous pseudogene replications were excluded from the matrix prior to all analyses (Koch et al., 2005). In addition, plastid and nuclear sequences of *Cardamine* and related genera from GenBank were imported into the matrices and aligned manually, resulting in a data set including a total of 111 species of *Cardamine* (Appendix 1). Several genera were tested as outgroup, but *Rorippa* was chosen in the end as the most suitable alternative because it was the closest related genus among the available genera.

Parsimony analyses were performed in Tree Analysis Using New Technology (TNT) (Goloboff et al., 2003) with potential parsimony informative gaps coded as present/absent (Simmons & Ochoterena, 2000). Heuristic searches were performed with 1000 random addition sequences and tree bisection-reconnection (TBR) branch swapping, saving 10 trees per replication. The resulting trees were swapped on with TBR saving up to 100,000 trees. Collapsing rule was set to minimum length – 0. Random seed was set to “time.” Goodness of fit was calculated using consistency index (CI), retention index (RI), and rescaled consistency index (RC) (Kluge & Farris, 1969; Farris, 1989). Bremer support (Bremer, 1994) was calculated by producing 120,000 trees that were up to 12 steps longer, starting with saving 10,000 trees one step longer, and successively saving 10,000 trees of up to one step longer in 11 steps. Jackknife (Farris et al., 1996) and bootstrap (Felsenstein, 1985) resampling were performed with 1000 replicates (10 random entry orders and 10 trees saved in each repetition) and collapsing rule – TBR. Jackknifing was performed with 36% deletion. Bootstrap and jackknife were performed with a cut-off value of 50% and absolute frequencies as output. Implied weighting (Goloboff, 1993) was performed with K – 1, 3, 6, 8, 20, and 50. In addition to the analysis of all taxa, separate analyses were performed on diploid taxa, tetraploid taxa, and diploid and tetraploid taxa together.

A Bayesian analysis was performed on the ITS data set in MrBayes (Huelsenbeck & Ronquist, 2001; Ronquist & Huelsenbeck, 2003) with the model general time reversible (GTR) + gamma provided by MrAIC (Nylander, 2004). The analysis was run with the default settings in MrBayes, random starting trees and run for 3,000,000 generations with sampling of Markov chains for each 100th generation. The first 25% of the trees were discarded as “burn-in” samples. A Bayesian analysis was also performed on the plastid data set, but did not provide any additional information and was thus excluded.

RESULTS

The final aligned ITS matrix included 629 characters, of which 188 were parsimony informative (186 when excluding the outgroup). There were four potential parsimony informative coded gaps in the data matrix (2 gaps of length 1 bp and 2 gaps of length 2 bp). The most parsimonious trees (MPTs) inferred from the ITS data set were 749 steps long with CI – 0.530, RI – 0.692, and RC – 0.367; one of them, as well as the strict consensus tree, is presented in Figure 1. The separate parsimony analyses of diploids, tetraploids, and diploids and tetraploids together did not give better resolution or conflicting topologies (result not shown). Using implied weighing did not give better resolution or conflicting topologies (result not shown). The Bayesian analysis of the ITS data set is presented in Figure 2.

We partitioned the ITS trees into nine operational groups to simplify presentation (marked A–J in Figs. 1, 2).

Group A was supported by a posterior probability (PP) of 0.96 and Bremer support (BR) – 1. This group included only diploid ($2n = 16$) European species (with *Cardamine bellidifolia* extending into the circumpolar area), four of them belonging to section *Cardaminella* (*C. alpina* Willd., *C. bellidifolia*, *C. plumieri* Vill., and *C. resedifolia* L.) and one (*C. carnosa* Waldst. & Kit.) to section *Pteroneurum* (DC.) Nyman.

Group B was supported by BR – 1 and comprised the East Asian *Cardamine tenuifolia* (Ledeb.) Turcz. of the monotypic section *Sphaerotorrhiza* O. E. Schulz and the African *C. trichocarpa* Hochst. ex A. Rich. of section *Cardamine*.

Group C was supported by BR – 1 and included Eurasian and North American taxa. North American high polyploids ($2n = 12x = 96$ to $2n = 32x = 256$) of section *Dentaria* (*Cardamine angustata* O. E. Schulz, *C. concatenata*, *C. dissecta* (Leavenw.) Al-Shehbaz, and *C. diphylla*) formed a clade supported by jackknife (JK) – 93%, bootstrap (BS) – 88%, BR – 5, and PP – 1.0. The European species of section *Dentaria* (*C. bipinnata* O. E. Schulz, *C. bulbifera* Crantz, *C. glanduligera* O. Schwarz, *C. abchasica* Govaerts, and *C. quinquefolia* (M. Bieb.) Benth. & Hook. f. ex Schmalh.) together with the Asian diploid *C. leucantha* O. E. Schulz of section *Macrophyllum* formed a clade supported by JK – 91%, BS – 87%, BR – 4, and PP – 1.0.

Group D was supported by BR – 1 and included the East Asian polyploids *Cardamine macrophylla* Willd. and *C. tangutorum* O. E. Schulz and the European diploid *C. trifolia* L., belonging to three different sections (*Macrophyllum*, *Dentaria*, and *Coriophyllum* O. E. Schulz, respectively).

Group E was supported by BR = 2 and PP = 1.0. This group included the European *Cardamine waldesteinii* Dyer of section *Dentaria* in addition to two well-supported clades with East Asian and North American taxa, respectively. The East Asian clade (JK = 98%, BS = 97%, BR = 5, and PP = 1.0) included members of sections *Cardaminella* (*C. nipponica* Franch. & Sav.) and *Cardamine* (*C. microzyga* O. E. Schulz). The North American clade (JK = 100%, BS = 99%, BR = 12, and PP = 1.0) also included the cosmopolitan weed *C. hirsuta* of section *Cardamine*.

Group F was supported by BR = 1 and PP = 1.0. This group included species of section *Cardamine* from South America, East Asia, and Africa.

Group G was supported by BR = 1 and PP = 0.98. This group included Eurasian, African, and South American taxa. Most Asian species grouped together, containing members of both sections *Cardamine* and *Macrophyllum*. Notably, the accessions of *C. scutata* Thunb. from Japan and Taiwan did not group together. The South American *C. ovata* Benth. grouped with African and South American *C. africana* L., both belonging to section *Papyrophyllum*. The chromosome numbers in this group spanned from $2n = 16$ (diploid) to $2n = 56$.

Group H was supported by JK = 65%, BS = 50%, BR = 4, and PP = 1.0. This group included a specimen from New Guinea referred to as *Cardamine africana*; it did not group with the other *C. africana* accessions (group G) and most likely represents a different taxon. All four species known from New Guinea belonged to this group, which also included European species of section *Dentaria* (*C. heptaphylla* (Vill.) O. E. Schulz, *C. kitaibelii* Bech., and *C. pentaphyllos* (L.) Crantz).

Group I was supported by BR = 1 and PP = 0.94. This group included the *Cardamine pratensis* species group and its closely related European species, which also formed a clade in the plastid analysis (Fig. 3; JK = 81%, BS = 81%, BR = 3). As this group has been extensively studied earlier (Franzke et al., 1998; Franzke & Hurka, 2000; Lihova & Marhold, 2003) and our analyses supported their findings without adding new information, we pruned several taxa of this complex from our final analyses and retained only four species related to *C. pratensis* to simplify this presentation (*C. acris* Griseb., *C. flaccida* Cham. & Schltdl., *C. pratensis*, and *C. tenera* S. G. Gmel. ex C. A. Mey.).

Group J had no support and was only present in the MPTs and a combinable components consensus tree, but included several supported subgroups. This group included most of the Beringian taxa, all of the Australian and New Zealand taxa, and many North American taxa in addition to one species from South

America and East Asia, respectively. The Australian and New Zealand taxa, *Cardamine debilis* Banks ex DC., *C. lacustris* (Garn.-Jones & P. N. Johnson) Heenan, *C. lilacina* Hook., and *C. paucijuga* Turcz., constituted a monophyletic group (JK = 55%, BS = 57%, BR = 1, and PP = 0.98) with the inclusion of the South American *C. glacialis* (G. Forst.) DC. and the amphi-Beringian/Pacific *C. umbellata* Greene. The ITS data set was inconclusive about the monophyly of the remaining Beringian species (*C. blaisdellii*, *C. digitata*, *C. purpurea*, *C. pedata*, *C. microphylla*, *C. victoris*, and *C. sphenophylla*). However, most of the MPTs supported the Beringian species as a monophyletic group with North American taxa as sister groups. The remaining trees supported the Beringian species as two separate groups, but both of them with North American species as sister groups. This led to the collapse of these branches in the strict consensus tree and the resampling analyses.

The South American species appeared scattered in the tree. *Cardamine glacialis* was most closely related to the taxa from Oceania in group J, *C. bonariensis* Pers. and *C. flaccida* close to or nested within the *C. pratensis* group in group I, and *C. ecuadorensis* Hieron. and *C. rhizomata* Rollins were resolved as a sister group to *C. griffithii* Hook. f. & Thomson in group F.

The three African species did not form a monophyletic group. *Cardamine trichocarpa* was found in group B, while *C. obliqua* Hochst. ex A. Rich. was sister to *C. lihengiana* Al-Shehbaz in group F with BR = 2 and PP = 0.96. A specimen from South America referred to *C. africana* was more closely related to South American *C. ovata* than to a *C. africana* specimen from Kilimanjaro.

The Oceanian taxa occurred in two distinct clades. In group H (JK = 65%, BS = 50%, BR = 4, and PP = 1.0), three European species were nested among four species from New Guinea (*Cardamine* sp. aff. *africana* L., *C. altigena* Schltr. ex O. E. Schulz, *C. keysseri* O. E. Schulz, and *C. papuana* O. E. Schulz). In group J, four species from Australia and New Zealand (*C. paucijuga*, *C. lilacina*, *C. lacustris*, and *C. debilis*) were most closely related (JK = 54%, BS = 57%, and PP = 0.98) to the Arctic *C. umbellata* and the South American *C. glacialis*.

The Beringian/circumpolar taxa occurred in three different groups. *Cardamine pratensis* (group I) and *C. bellidifolia* (group A) had their closest relatives in Europe. In group J, there were seven Beringian species (*C. blaisdellii*, *C. digitata*, *C. purpurea*, *C. pedata*, *C. microphylla*, *C. victoris*, and *C. sphenophylla*) possibly having their closest relatives in Oceania and North America.

The aligned *trnL-F* matrix included 765 characters, 77 of which were parsimony informative (71 when

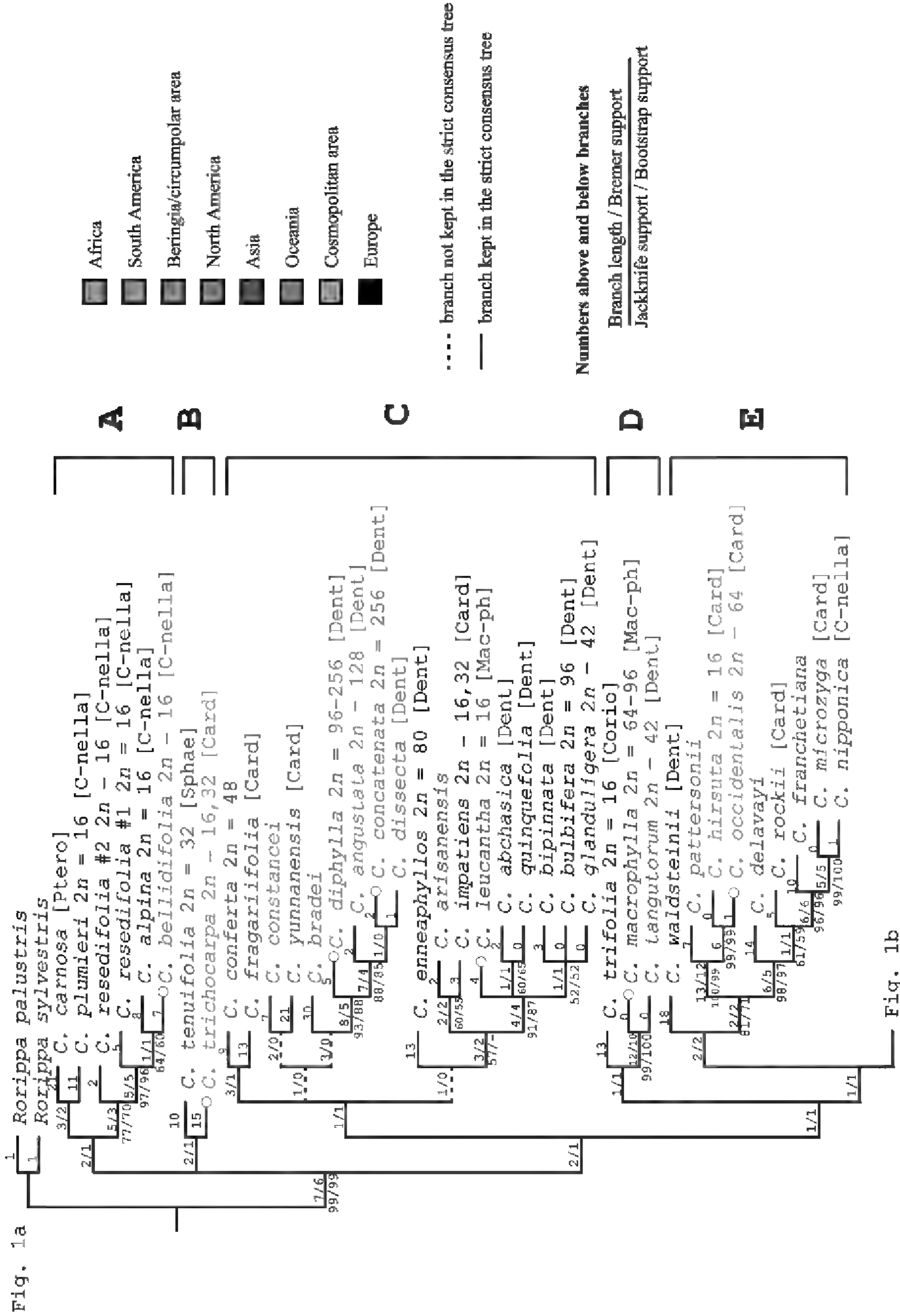

Figure 1. One of the MPTs based on the ITS data set showing branches kept in the strict consensus tree. The tree length is 749 steps and the goodness of fit values are CI = 0.530, RI = 0.692, and RC = 0.367. Numbers above branches indicate branch lengths/Bremer support. Numbers below branches indicate jackknife support/Bootstrap support. To simplify presentation, multiple accessions of the same taxon are indicated with a single open circle for the terminal. Chromosome numbers are given after the species name based on previously published data summarized in Kucera et al. (2005) and are followed by the section name in brackets (cf. Table 1). Letters A–J designate groups commented on in the text.

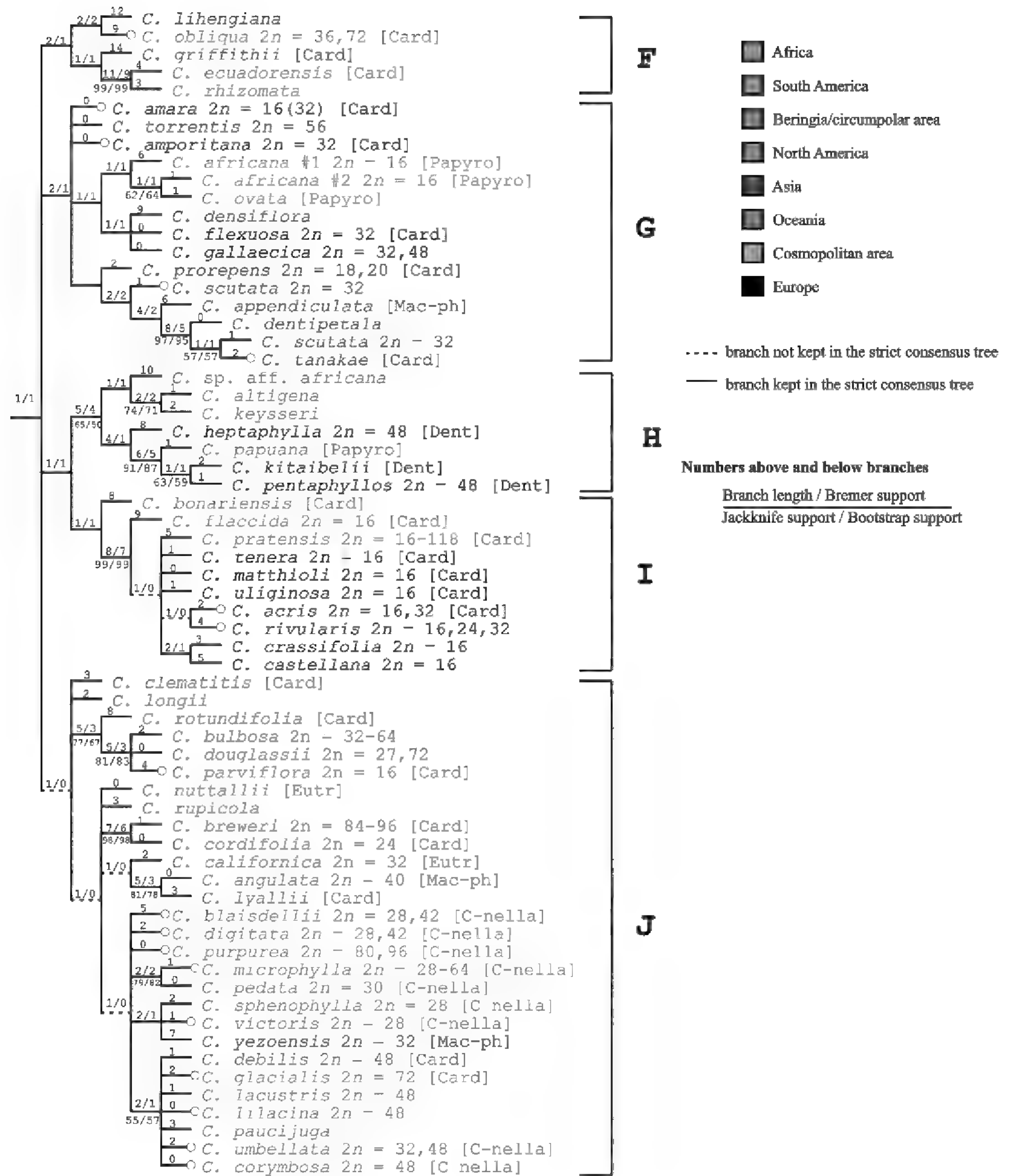

Figure 1. Continued.

excluding the outgroup). There were 11 potential parsimony informative coded gaps in the data matrix with lengths spanning from 1 bp to 11 bp. The MPTs resulting from the *trnL-F* analysis were 258 steps long with CI = 0.694, RI = 0.807, and RC = 0.560; one of them, as well as the strict consensus tree, is presented in Figure 3. In terms of initial similarity retained as synapomorphy (RI), the plastid characters were more self-congruent than the ITS characters. The analysis

of the plastid data set (Fig. 3) resulted in a poorly resolved strict consensus tree, but several interesting groups were recovered in the analyses. The European diploid *Cardaminella* taxa (*Cardamine bellidifolia*, *C. alpina*, and *C. resedifolia*) constituted a monophyletic group with 91% JK support, 88% BS support, and a BR support of 2 with *C. glauca* Spreng. as sister (JK = 67%, BS = 55%, and BR = 1). There was also support (BR = 1) for monophyly of the Oceanian

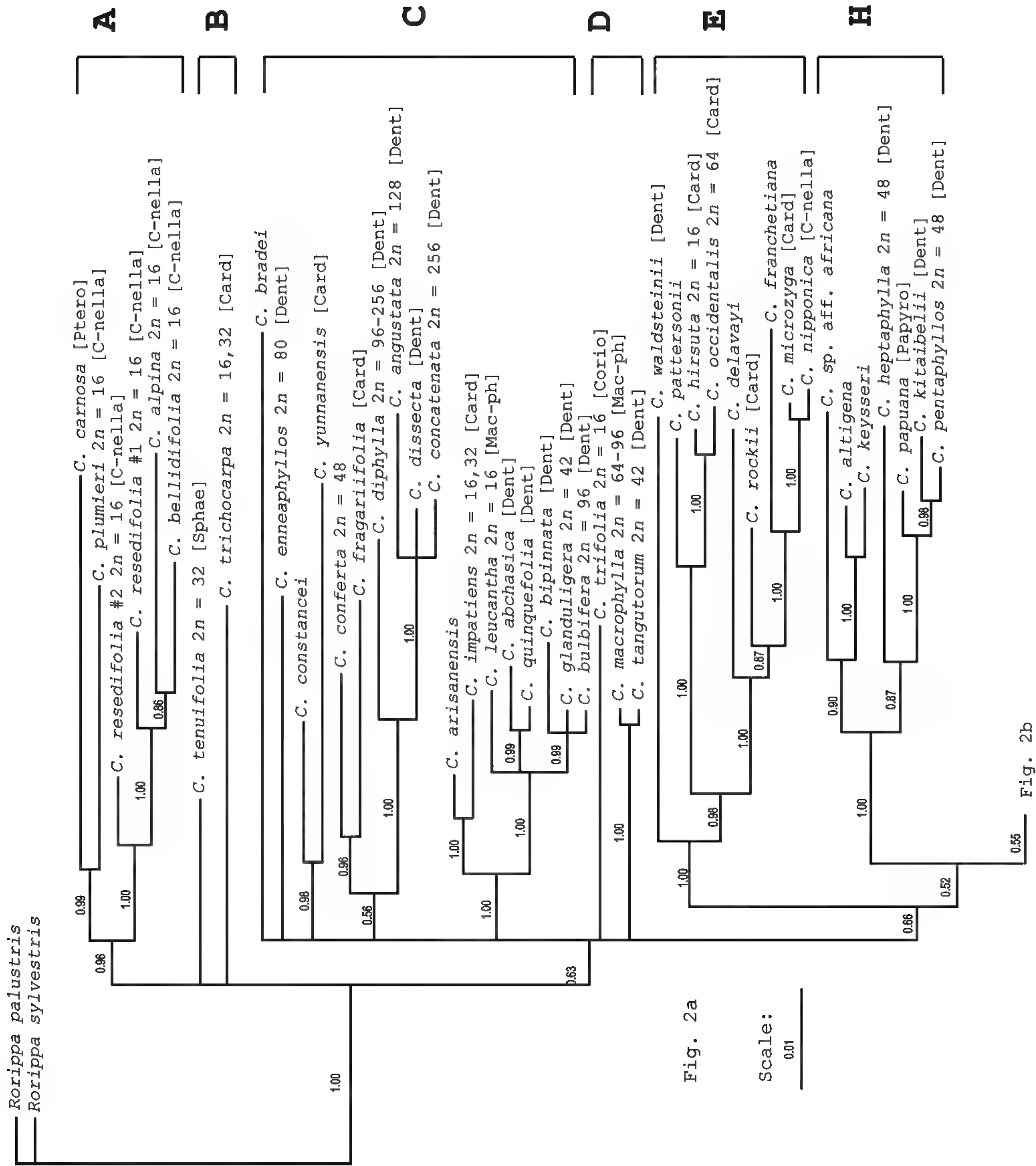

Figure 2. Bayesian phylogram based on the ITS data set. Numbers above branches indicate posterior probabilities. Chromosome numbers are given after the species name based on previously published data summarized in Kucera et al. (2005) and are followed by the section name in brackets (cf. Table 1). Letters A–J designate groups commented on in the text.

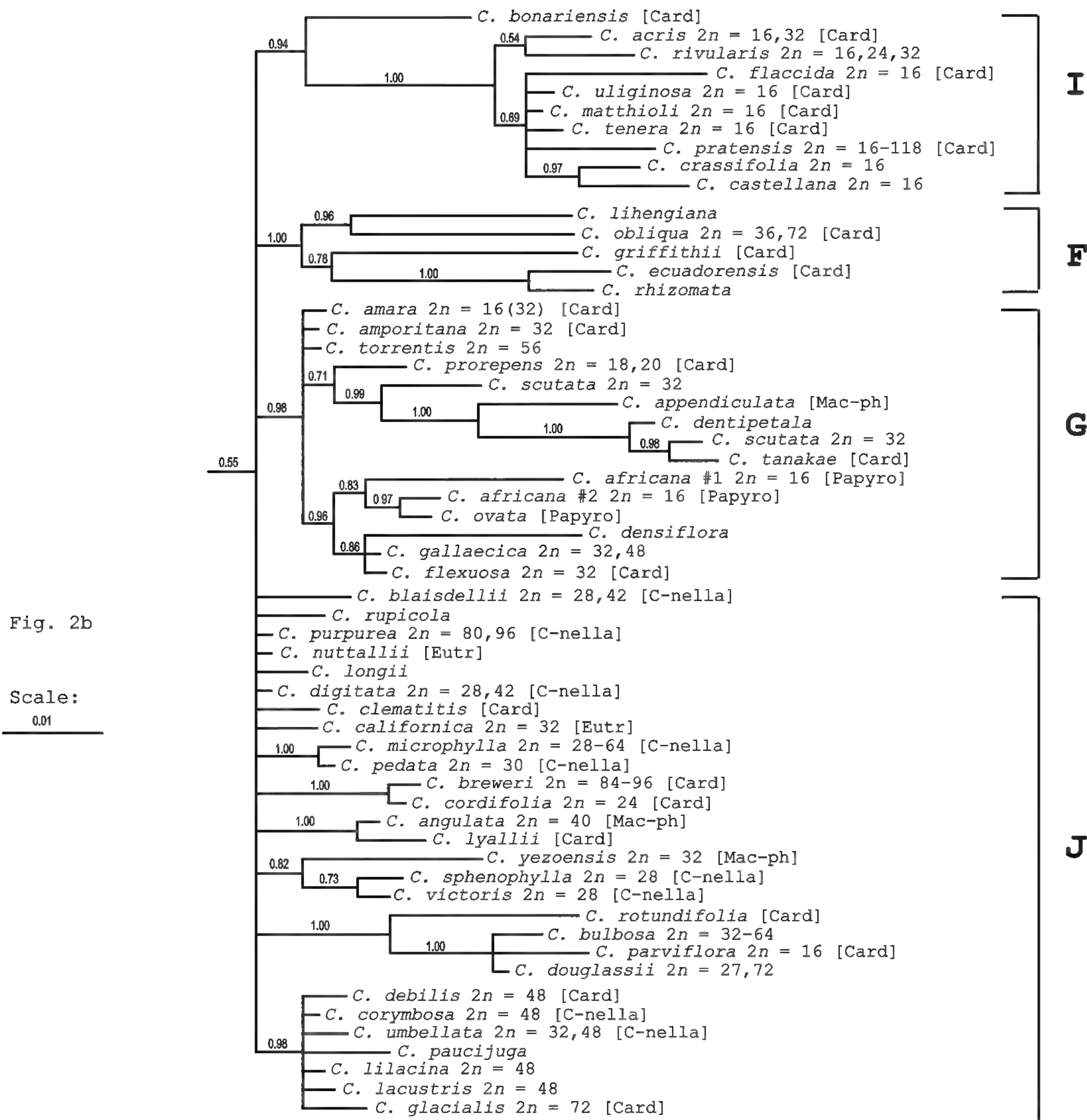

Figure 2. Continued.

Cardaminella species (*C. corymbosa* Hook. f., *C. debilis*, and *C. lilacina*) with the inclusion of the Beringian *C. victoris* and *C. umbellata*, the North American *C. cordifolia* A. Gray, and the South American *C. glacialis*. The four European species previously shown to be related to the *C. pratensis* complex (*C. pratensis*, *C. matthioli* Moretti ex Comolli, *C. penzesii* Ančev & Marhold, and *C. rivularis* Schur) formed a group supported by 81% in both JK and BS, and 3 in BR. The North American high polyploids (*C. angustata*, *C. concatenata*, *C. diphylla*, and *C. dissecta*) also formed a clade (JK – 82%, BS – 76%, and BR – 1).

DISCUSSION

RAPID DIVERSIFICATION AND WIDESPREAD POLY PLOIDIZATION

Although 29% of the characters in the ITS data set were phylogenetically informative, only a few of them were useful for resolving deeper relationships in *Cardamine*. Even though the overall RI for the ITS trees might suggest that there is substantial homoplasy in the data set, with 31% of all characters being retained as such, implied weighting did not affect the topology or improve the resolution of the deeper relationships as one might expect when reducing the effect of homoplastic characters. The most likely

Fig. 3a

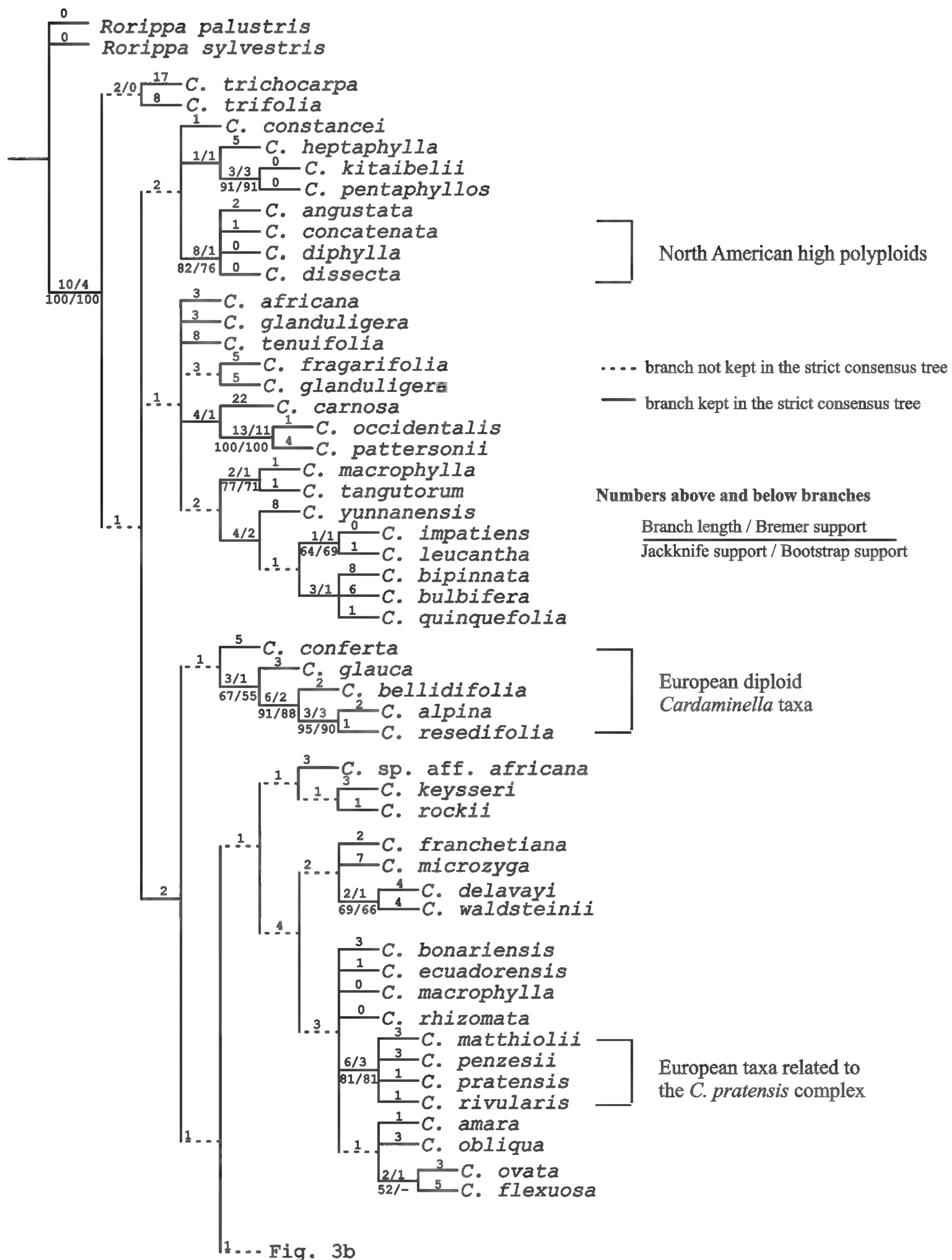

Figure 3. One of the MPTs based on the *trnL-F* data set showing branches kept in the strict consensus tree. Numbers above branches are Bremer support values. Numbers below branches are jackknife/bootstrap support values.

explanation for the lack of resolution is, therefore, that the initial diversification in *Cardamine* occurred rapidly.

Polyploidization, a common mode of evolution in *Cardamine* as well as in the Brassicaceae in general

(Al-Shehbaz, 1988; Kucera et al., 2005; Beilstein et al., 2006; Marhold & Lihova, 2006), also could have affected the resolution of the ITS phylogeny. Our results imply that polyploidization has happened independently in many lineages in *Cardamine*. We

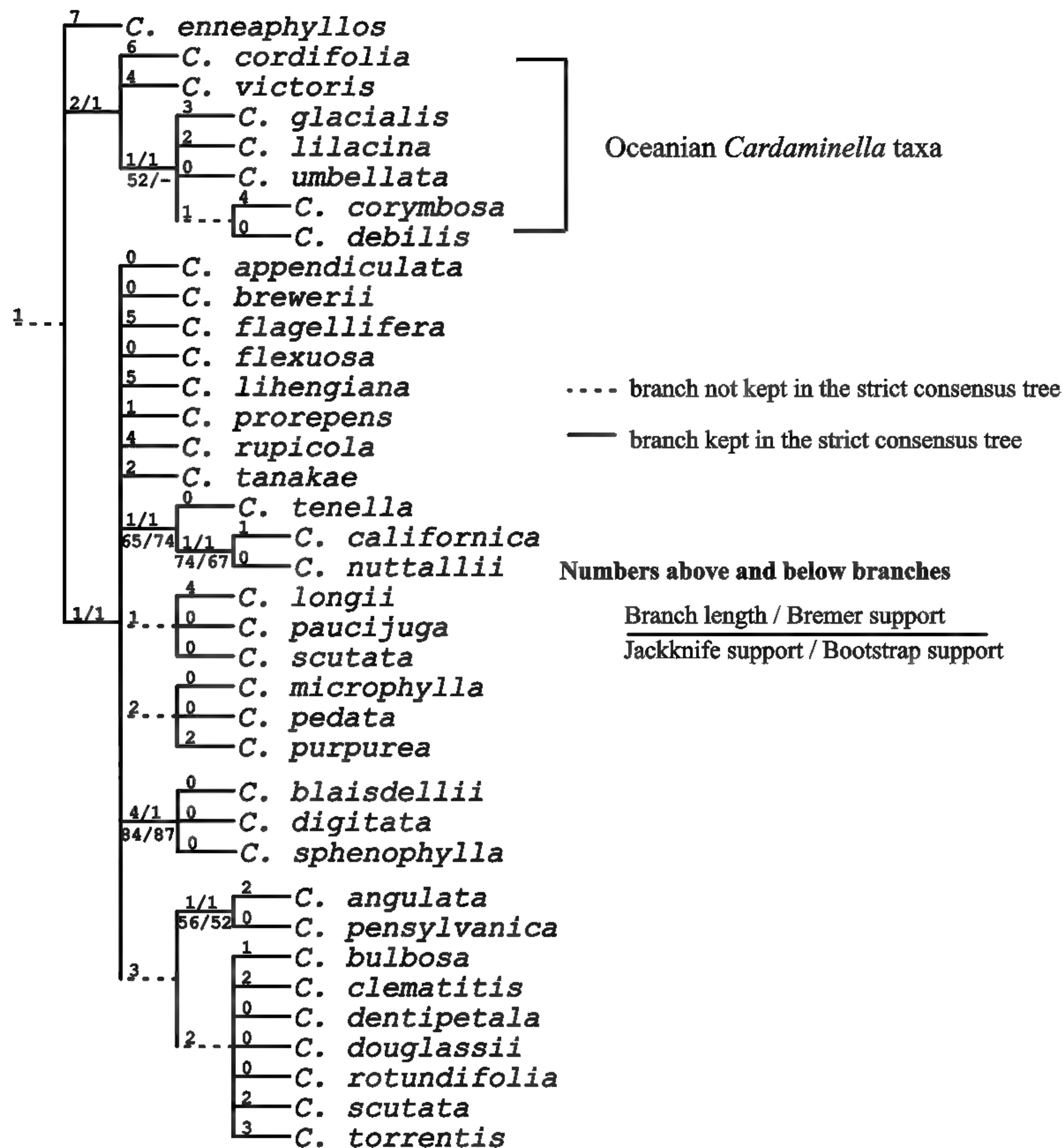

Figure 3. Continued.

found that nine of the 10 groups (noted A–J in Results and Figs. 1 and 2) contain diploid species, that only one group is exclusively diploid (group A), and that most groups contain species that are hexaploid or even higher. However, our separate analyses of the ITS region for diploids and tetraploids did not provide better resolution or conflicting topologies, nor did the plastid tree show better resolution. These results support our hypothesis that the lack of resolution is due to rapid speciation rather than breakdown of phylogenetic signal from frequent allopolyploidization.

Untangling the hierarchical structure among rapidly diverging lineages is difficult and requires a huge sequencing effort (Fishbein et al., 2001). We did an extensive survey of different regions in the preliminary analyses for this study, and a search for more phylogenetically informative molecular markers in *Cardamine* may prove fruitless.

Our results corroborate those of Koch et al. (2000) and Haubold and Wiehe (2001), who used molecular dating to demonstrate that *Cardamine* is a relatively young genus. After the split between *Cardamine* and *Barbarea* as late as 6.2 Ma (2–8 Ma), *Cardamine*

rapidly diversified into one of the most species-rich genera in the Brassicaceae. This is consistent with the pattern observed in other large genera of this family, such as *Lepidium* L. (2.1–4.2 Ma, ca. 175 species; Mummenhoff et al., 2001) and *Draba* L. (4.5–9 Ma, ca. 350 species; Koch & Al-Shehbaz, 2002).

Several papers have addressed the importance and previous underestimation of long-distance dispersals to explain biogeographic patterns (Donoghue & Smith, 2004; Givnish & Renner, 2004; Thorne, 2004; Cook & Crisp, 2005; McGlone, 2005; Queiroz, 2005; Graham, 2006). In *Cardamine*, continental drift causing vicariant speciation can be ruled out because the present constellation of continents was established millions of years before the origin of the genus. Based on the estimate of 2–8 Ma, it is likely that the large late Tertiary forest in the Northern Hemisphere (Lafontaine & Wood, 1988; Bennike & Böcher, 1990; Matthews & Oviden, 1990; Murray, 1995; Graham, 1999) provided the first habitat for establishment, divergence, and spread of *Cardamine*. It is possible that the later submerging of the Bering Land Bridge (Gladenkov et al., 2002) and the successive cooling of the Holarctic region (Zachos et al., 2001)

has caused vicariant speciation in the genus. Despite its low overall resolution, our phylogeny nevertheless provides evidence for several extensive long-distance dispersal events (further discussed below).

SECTIONAL PARTITIONING

We found no support for monophyly of any of Schulz's (1903, 1936) large sections (Figs. 1–3). Section *Cardaminella* was not monophyletic; the species of this section occurred in different supported clades intermingled with species of other sections (compare clades in groups A, E, and J; Figs. 1, 2). Our results also reject the monophyly of section *Dentaria*, in agreement with Franzke et al. (1998) and Sweeney and Price (2000). Furthermore, the species included in the largest section, *Cardamine*, are spread among different supported groups and intermingled with species of other sections (e.g., groups G and J). This section has apparently served to include species that did not fit morphologically into any of the other 12 sections, as suggested by Sweeney and Price (2000). We have also shown that *Macrophyllum* and *Papyrophyllum* are not monophyletic, in agreement with Bleeker et al. (2002) and Sweeney and Price (2000; cf. Figs. 1–3).

RAPID COLONIZATION AND SUBSEQUENT DISPERSALS

Because of its poor resolution, our phylogeny was not suitable for biogeographic analyses such as DIVA to reconstruct ancestral areas (Ronquist, 1997). However, because of the considerably higher diversity of species and, in particular, diploid ones, Eurasia is certainly the most likely area of origin of *Cardamine*. Despite its typically short-distance main mode of dispersal, we hypothesize that the genus rapidly colonized and diversified in the entire Northern Hemisphere (Asia, Europe, and North America). Then, at a later stage, it spread across vast distances to the Southern Hemisphere as several distinct lineages (cf. also Bleeker et al., 2002). Both Eurasia and North America are likely source areas for dispersals to the Southern Hemisphere. Some distinct colonization episodes can be inferred based on supported groupings in our phylogeny and are shown in Figure 4.

Oceania. One example of very long-distance colonization (arrow f in Fig. 4) followed by rapid speciation is provided by the Australian and New Zealand taxa, which form a monophyletic group together with one Beringian (*Cardamine umbellata*) as well as one South American species (*C. glacialis*; subclade in J, Figs. 1, 2). Notably, these Oceanian species are morphologically diverse and comprise

lowland as well as alpine taxa, but appear genetically similar. The four Oceanian species from New Guinea (*C. sp. aff. africana*, *C. altigena*, *C. keysseri*, and *C. papuana*), on the other hand, belonged to another distinct clade, which also comprised Northern Hemisphere taxa (group H; Figs. 1, 2). Thus, Oceania appears to have been colonized at least twice from the Northern Hemisphere.

South America. We can discern at least four different dispersals into South America, two of which might originate from other Southern Hemisphere regions. We have shown that the accessions of *Cardamine africana* are monophyletic only by the inclusion of the South American *C. ovata*, which were suggested to be conspecific with *C. africana* earlier (Sjöstedt, 1975) (see subclade in group G). This must represent an independent dispersal event into South America, either from Africa or from the Northern Hemisphere with later dispersal to Africa (arrow d in Fig. 4). Long-distance dispersal from Africa to South America is not an impossible scenario (Graham, 2006).

As noted above, the South American *Cardamine glacialis* is most closely related to the species from Australia, Tasmania, and New Zealand in both the *trnL-F* (JK – 52%, BR – 1) and ITS (JK – 55%, BS – 57%, BR – 1, PP – 0.98) tree, and must represent a separate dispersal event into South America (arrow g in Fig. 4; subclade in group J).

The South American *Cardamine flaccida* and *C. bonariensis*, suggested by Sjöstedt (1975) to be conspecific, form a clade with the European *C. pratensis* complex and thus provide an example of yet another dispersal event (arrow c in Fig. 4; group I in Figs. 1, 2). From the parsimony ITS tree, the direction is impossible to determine as both ways are equally parsimonious (Cook & Crisp, 2005). We can infer either two dispersal events into South America or one old dispersal event to South America with a subsequent speciation event and then dispersal back to Europe.

Evidence for a fourth dispersal event into South America is provided by the sister group relationship (PP – 0.78, BR – 1) between the Asian *Cardamine griffithii* and the South American *C. ecuadorensis* and *C. rhizomata*, which form a separate clade within group F and may have originated from Eurasia (not indicated in Fig. 4). Our results reject Sjöstedt's (1975) hypothesis that *C. ecuadorensis* and *C. rhizomata* are conspecific with *C. africana*.

Africa. The African species did not form a monophyletic group in our analyses. The sister group of the African *Cardamine obliqua* differs between the ITS tree (group F) and the plastid tree, as also found by Bleeker et al. (2002), but it is possible that it has a



Figure 4. Map defining areas as used in the text and in Figures 1 and 2. Arrows indicate inferred major dispersal events discussed in the text (marked a–h).

Eurasian origin (arrow e in Fig. 4). The African *C. trichocarpa* (see group B) is highly divergent with its 15 ITS and 17 *trnL-F* autapomorphies and has no unambiguous sister group. It is not possible to infer its origin except that it is not sister to the other African taxa. Finally, *C. africana*, which occurs both in Africa and South America (cf. above), is member of yet another clade, nested with European and Asian taxa (group G; PP = 0.98 and BR = 1).

The Arctic. We can infer at least three major colonization episodes into the Beringian/circumpolar region. Many species of *Cardamine* reach the Arctic (e.g., *C. macrophylla*, *C. conferta* Jurtzev, *C. tenuifolia*, *C. prorepens* Fisch. ex DC., *C. scutata*, and *C. amara* L.), but here we focus on the nine taxa having the major part of their distribution in this region (*C. bellidifolia*, *C. blaisdellii*, *C. digitata*, *C. pratensis*, *C. purpurea*, *C. pedata*, *C. microphylla*, *C. victoris*, and *C. sphenophylla*).

Both the chloroplast and nuclear data demonstrate that the broadly circumpolar diploid *Cardamine bellidifolia* in group A is sister (JK = 77%, BS = 70%, PP = 1.0, and BR = 3 in ITS and JK = 91%, BS = 88%, and BR = 2 in *trnL-F*) to European diploids, specifically in the Alps and Pyrenees (arrow b in Fig. 4). This clade is sister to other European Mediterranean–Alpine diploids such as *C. glauca* in the *trnL-F* tree (JK = 67%, BS = 55%, and BR = 1) and *C. carnosa* and *C. plumieri* in the ITS tree (PP = 0.96 and BR = 1).

Another example of European origin is provided by the Arctic circumpolar *Cardamine pratensis* (group I). The Arctic specimens are regarded as a separate subspecies, *C. pratensis* subsp. *angustifolia* (Hook.) O. E. Schulz, which some authors regard as a separate species, *C. nymanii* Gand. (Franzke & Mummenhoff, 1999). *Cardamine pratensis* is a common boreal polyploid and belongs to a complicated species complex with many described diploids and low polyploids distributed throughout Europe. Our results are consistent with those of Franzke and Hurka (2000), who concluded that *C. pratensis* colonized the Arctic from southern Europe during the Holocene (arrow h in Fig. 4).

The remaining seven Arctic species (group J), which are restricted to the amphi-Beringian region, may have originated from one or two colonization events from North America (arrow a in Fig. 4), as these taxa are nested with other North American species. However, this is only inferred from the MPTs and the combinable components tree. Because we use collapsing rules that do not allow zero length branches, we did not get support for this hypothesis in the resampling analyses.

Thus, there are two distinct examples of European origin of Arctic *Cardamine*, including two different species that have become broadly distributed in the Arctic without further diversification. In addition, there is one example of a probable North American origin followed by diversification into many species in Beringia, but without further expansion into the circumpolar.

Literature Cited

- Al-Shehbaz, I. A. 1988. The genera of Arabideae (Cruciferae, Brassicaceae) in the southeastern United States. *J. Arnold Arb.* 69: 85–166.
- , M. A. Beilstein & E. A. Kellogg. 2006. Systematics and phylogeny of the Brassicaceae (Cruciferae): An overview. *Pl. Syst. Evol.* 259: 89–120.
- Beilstein, M. A., I. A. Al-Shehbaz & E. A. Kellogg. 2006. Brassicaceae phylogeny and trichome evolution. *Amer. J. Bot.* 93: 607–619.
- Bennike, O. & J. Böcher. 1990. Forest-tundra neighbouring the North Pole—Plant and insect remains from the Pliocene–Pleistocene Kap København formation, North Greenland. *Arctic* 43: 331–338.
- Bleeker, W. & H. Hurka. 2001. Introgressive hybridization in *Rorippa* (Brassicaceae): Gene flow and its consequences in natural and anthropogenic habitats. *Molec. Ecol.* 10: 2013–2022.
- , A. Franzke, K. Pollmann, A. H. D. Brown & H. Hurka. 2002. Phylogeny and biogeography of Southern Hemisphere high-mountain *Cardamine* species (Brassicaceae). *Austral. Syst. Bot.* 15: 575–581.
- Bremer, K. 1994. Branch support and tree stability. *Cladistics* 10: 295–304.
- Cook, L. G. & M. D. Crisp. 2005. Directional asymmetry of long-distance dispersal and colonization could mislead reconstructions of biogeography. *J. Biogeogr.* 32: 741–754.
- Donoghue, M. J. & S. A. Smith. 2004. Patterns in the assembly of temperate forests around the Northern Hemisphere. *Philos. Trans., Ser. B* 359: 1633–1644.
- Elven, R., D. F. Murray, V. Y. Razzhivin & B. A. Yurtsev. 2006. Panarctic Flora Checklist. Vascular Plants Draft version (2006). National Centre for Biosystematics, University of Oslo, Oslo. <<http://www.binran.ru/infosys/paflist/index.htm>>, accessed 16 April 2009.
- Farris, J. S. 1989. The retention index and the rescaled consistency index. *Cladistics* 5: 417–419.
- , V. A. Albert, M. Källersjö, D. Lipscomb & A. G. Kluge. 1996. Parsimony jackknifing outperforms neighbor-joining. *Cladistics* 12: 99–124.
- Felsenstein, J. 1985. Confidence limits on phylogenies: An approach using the bootstrap. *Evolution* 4: 783–791.
- Fishbein, M., C. Hirsch-Jetter, D. Soltis & L. Hufford. 2001. Phylogeny of Saxifragales (angiosperms, eudicots): Analysis of a rapid, ancient radiation. *Syst. Biol.* 50: 817–847.
- Franzke, A. & K. Mummenhoff. 1999. Recent hybrid speciation in *Cardamine* (Brassicaceae)—Conversion of nuclear ribosomal ITS sequences in statu nascendi. *Theor. Appl. Genet.* 98: 831–834.
- & H. Hurka. 2000. Molecular systematics and biogeography of the *Cardamine pratensis* complex (Brassicaceae). *Pl. Syst. Evol.* 224: 213–234.
- , K. Pollmann, W. Bleeker, R. Kohrt & H. Hurka. 1998. Molecular systematics of *Cardamine* and allied genera (Brassicaceae): ITS and non-coding chloroplast DNA. *Folia Geobot.* 33: 225–240.

- Givnish, T. J. & S. S. Renner. 2004. Tropical intercontinental disjunctions: Gondwana breakup, immigration from the boreotropics, and transoceanic dispersal. *Int. J. Pl. Sci.* 165: S1–S6.
- Gladenkov, A. Y., A. E. Oleinik, J. L. Marinovich & K. B. Barinov. 2002. A refined age for the earliest opening of Bering Strait. *Palaeogeogr. Palaeoclimatol. Palaeoecol.* 183: 321–328.
- Goloboff, P. A. 1993. Estimating character weights during tree search. *Cladistics* 9: 83–91.
- , J. Farris & K. Nixon. 2003. TNT (Tree analysis using New Technology). Published by the authors, Tucumán, Argentina.
- Graham, A. 1999. Late Cretaceous and Cenozoic History of North American Vegetation North of Mexico. Oxford University Press, New York.
- . 2006. Modern processes and historical factors in the origin of the African element in Latin America. *Ann. Missouri Bot. Gard.* 93: 335–339.
- Hall, T. A. 1999. BioEdit: A user-friendly biological sequence alignment editor and analysis program for Windows 95/98/NT. *Nucl. Acids Symp. Ser.* 41: 95–98.
- Harriman, N. A. 1965. The Genus *Dentaria* (Cruciferae) in Eastern North America. Ph.D. Dissertation, Vanderbilt University, Nashville.
- Haubold, B. & T. Wiehe. 2001. Statistics of divergence times. *Molec. Biol. Evol.* 18: 1157–1160.
- Hedges, M. 2005. Dating nodes on molecular phylogenies: A critique of molecular biogeography. *Cladistics* 21: 62–78.
- Hewson, H. J. 1982. Flora of Australia. Australian Government Publishing Service, Canberra.
- Hofacker, I. L., W. Fontana, P. F. Stadler, S. Bonhoeffer, M. Tacker & P. Schuster. 1994. Fast folding and comparison of RNA secondary structures. *Monatsh. Chem.* 125: 167–188.
- Huelsenbeck, J. P. & F. Ronquist. 2001. MRBAYES: Bayesian inference of phylogenetic trees. *Bioinformatics* 17: 754–755.
- Kimata, M. 1983. Comparative studies on the reproductive systems of *Cardamine flexuosa*, *Cardamine impatiens*, *Cardamine scutata*, and *Cardamine lyrata*, Cruciferae. *Bot. Mag. (Tokyo)* 96: 299–312.
- Kluge, A. G. & J. S. Farris. 1969. Quantitative phyletics and evolution of Anurans. *Syst. Zool.* 18: 1–32.
- Koch, M. & I. A. Al-Shehbaz. 2002. Molecular data indicate complex intra- and intercontinental differentiation of American *Draba* (Brassicaceae). *Ann. Missouri Bot. Gard.* 89: 88–109.
- , B. Haubold & T. Mitchell-Olds. 2000. Comparative evolutionary analysis of chalcone synthase and alcohol dehydrogenase loci in *Arabidopsis*, *Arabis*, and related genera (Brassicaceae). *Molec. Biol. Evol.* 17: 1483–1498.
- , ——— & ———. 2001. Molecular systematics of the Brassicaceae: Evidence from coding plastidic *matK* and nuclear *Chs* sequences. *Amer. J. Bot.* 88: 534–544.
- , C. Dobes, M. Matschinger, W. Bleeker, J. Vogel, M. Kiefer & T. Mitchell-Olds. 2005. Evolution of the *trnF* (GAA) gene in *Arabidopsis* relatives and the Brassicaceae family: Monophyletic origin and subsequent diversification of a plastidic pseudogene. *Molec. Biol. Evol.* 22: 1032–1043.
- Kucera, J., I. Valko & K. Marhold. 2005. On-line database of the chromosome numbers of the genus *Cardamine* (Brassicaceae). *Biologia* 60: 473–476.
- Lafontaine, J. D. & D. M. Wood. 1988. A zoogeographic analysis of the Noctuidae (Lepidoptera) of Beringia, and some inferences about past Beringian habitats. *Mem. Entomol. Soc. Canad.* 144: 109–123.
- Lear, C. H., H. Elderfield & P. A. Wilson. 2000. Cenozoic deep-sea temperatures and global ice volumes from Mg/Ca in benthic foraminiferal calcite. *Science* 287: 269–272.
- Lihova, J. & K. Marhold. 2003. Taxonomy and distribution of the *Cardamine pratensis* group (Brassicaceae) in Slovenia. *Phyton (Horn)* 43: 241–261.
- , J. Fuertes Aguilar, K. Marhold & G. Nieto Feliner. 2004. Origin of the disjunct tetraploid *Cardamine amporitana* (Brassicaceae) assessed with nuclear and chloroplast DNA sequence data. *Amer. J. Bot.* 91: 1231–1242.
- Mai, D. H. 1995. Tertiäre Vegetationsgeschichte Europas. Gustav Fischer Verlag, Jena.
- Marhold, K. & M. E. Ancey. 1999. *Cardamine penzesii*, a rediscovered taxon of the *C. pratensis* group (Cruciferae). *Ann. Bot. Fenn.* 36: 171–180.
- & J. Lihova. 2006. Polyploidy, hybridization and reticulate evolution: Lessons from the Brassicaceae. *Pl. Syst. Evol.* V259: 143–174.
- , ———, M. Perny, R. Grupe & B. Neuffer. 2002. Natural hybridization in *Cardamine* (Brassicaceae) in the Pyrenees: Evidence from morphological and molecular data. *Bot. J. Linn. Soc.* 139: 275–294.
- , ———, ——— & W. Bleeker. 2004. Comparative ITS and AFLP analysis of diploid *Cardamine* (Brassicaceae) taxa from closely related polyploid complexes. *Ann. Bot. (Oxford)* 93: 507–520.
- Marinovich, L. 2001. New evidence for the age of Bering Strait. *Quatern. Sci. Rev.* 20: 329–335.
- & A. Y. Gladenkov. 1999. Evidence for an early opening of the Bering Strait. *Nature* 397: 149–151.
- Matthews, J. V. & L. E. Ovenden. 1990. Late Tertiary plant macrofossils from localities in Arctic sub-arctic North America—A review of the data. *Arctic* 43: 364–392.
- McGlone, M. S. 2005. Goodbye Gondwana. *J. Biogeogr.* 32: 739–740.
- Mitchell, A. D. & P. B. Heenan. 2000. Systematic relationships of New Zealand endemic Brassicaceae inferred from nrDNA ITS sequence data. *Syst. Bot.* 25: 98–105.
- Mummenhoff, K., H. Bruggemann & J. L. Bowman. 2001. Chloroplast DNA phylogeny and biogeography of *Lepidium* (Brassicaceae). *Amer. J. Bot.* 88: 2051–2063.
- Murray, D. F. 1995. Causes of Arctic plant diversity: Origin and evolution. *Ecol. Stud.* 113: 21–32.
- Nylander, J. A. A. 2004. MrAIC.pl. Program distributed by the author. Evolutionary Biology Centre, Uppsala University, Uppsala.
- Queiroz, A. de. 2005. The resurrection of oceanic dispersal in historical biogeography. *Trends Ecol. Evol.* 20: 68–73.
- Rashid, A. & H. Ohba. 1993. A revision of *Cardamine loxostemonoides* O. E. Schulz (Cruciferae). *J. Japan. Bot.* 68: 199–208.
- Ronquist, F. 1997. Dispersal-vicariance analysis: A new approach to the quantification of historical biogeography. *Syst. Biol.* 46: 195–203.
- & J. P. Huelsenbeck. 2003. MrBayes 3: Bayesian phylogenetic inference under mixed models. *Bioinformatics* 19: 1572–1574.
- Schulz, O. E. 1903. Monographie der Gattung *Cardamine*. *Bot. Jahrb. Syst.* 32: 280–623.
- . 1936. Cruciferae. Pp. 227–658 in A. Engler & H. Harms (editors), *Die natürlichen Pflanzenfamilien*. Engelmann, Leipzig.
- Siebert, S. & R. Backofen. 2005. MARNA: Multiple alignment and consensus structure prediction of RNAs based on sequence structure comparisons. *Bioinformatics* 21: 3352–3359.

- Simmons, M. P. & H. Ochoterena. 2000. Gaps as characters in sequence-based phylogenetic analyses. *Syst. Biol.* 49: 369–381.
- Sjöstedt, B. 1975. Revision of genus *Cardamine* L. (Cruciferae) in South America and Central America. *Bot. Not.* 128: 8–19.
- Sweeney, P. W. & R. A. Price. 2000. Polyphyly of the genus *Dentaria* (Brassicaceae): Evidence from *trnL* intron and *ndhF* sequence data. *Syst. Bot.* 25: 468–478.
- Taberlet, P., L. Gielly, G. Pautou & J. Bouvet. 1991. Universal primers for amplification of three noncoding regions of chloroplast DNA. *Pl. Molec. Biol.* 17: 1105–1109.
- Thorne, R. 2004. Tropical plant disjunctions: A personal reflection. *Int. J. Pl. Sci.* 165: S137–S138.
- Warwick, S. I. & I. A. Al-Shehbaz. 2006. Brassicaceae: Chromosome number index and database on CD-Rom. *Pl. Syst. Evol.* 259: 237–248.
- Webb, C. J., W. R. Sykes & P. J. Garnock-Jones. 1988. Flora of New Zealand. Botany Division, Department of Scientific and Industrial Research, Christchurch.
- White, T., T. Bruns, S. Lee & J. Taylor. 1990. Amplification and direct sequencing of fungal ribosomal RNA genes for phylogenetics. Pp. 315–322 in M. A. Innis, D. H. Gelfand, J. J. Sninsky & T. J. White (editors), *PCR Protocols: A Guide to Methods and Applications*. Academic Press, San Diego.
- Yang, Y. W., K. N. Lai, P. Y. Tai, D. P. Ma & W. H. Li. 1999. Molecular phylogenetic studies of *Brassica*, *Rorippa*, *Arabidopsis*, and allied genera based on the internal transcribed spacer region of 18S-25S rDNA. *Molec. Phylogenet. Evol.* 13: 455–462.
- Zachos, J., M. Pagani, L. Sloan, E. Thomas & K. Billups. 2001. Trends, rhythms, and aberrations in global climate 65 Ma to present. *Science* 292: 686–693.

APPENDIX 1. Specimens included in this study. Section is given for species where it has been applied. Chromosome counts in parentheses refer to rare reports for species where multiple counts have been performed. Sequences taken from GenBank are listed with reference numbers and the corresponding publication. GenBank accession numbers for sequences produced for this publication are listed for each species and under each DNA region.

Species	Section	2n –	Country/Territory (Herbarium) Collector/Determinator ^a	ITS	<i>trnL</i> intron	<i>trnL-F</i> spacer
<i>Rorippa palustris</i> (L.) Bess.		32	Germany, Franzke et al., 1998; Bleeker & Hurka, 2001	AF078021, AF078022	AF079351	AF363669
<i>R. sylvestris</i> (L.) Bess.		48	Germany, Franzke et al., 1998; Bleeker & Hurka, 2001	AF078023, AF078024	AF079352	AF362644
<i>Cardamine abchasica</i> Govaerts	<i>Dentaria</i>		Georgia (WU)	FJ464476, FJ464499		
<i>C. acris</i> Griseb.	<i>Cardamine</i>	16	Montenegro, Marhold et al., 2004	AY245977, AY246007		
<i>C. acris</i>	<i>Cardamine</i>	16	Greece, Marhold et al., 2004	AY246002, AY246032		
<i>C. sp. aff. africana</i> L. ^b	<i>Papyrophyllum</i>	16	Papua New Guinea, Franzke et al., 1998; Bleeker et al., 2002	AF078009, AF078010	AF079342	AY047650
<i>C. africana</i> L. #1	<i>Papyrophyllum</i>	16	Tanzania, Bleeker et al., 2002	AY047612, AY047623	AY047639	AY047655
<i>C. africana</i> #2	<i>Papyrophyllum</i>	16	Ecuador, Bleeker et al., 2002	AY047611, AY047622	AY047642	AY047658
<i>C. alpina</i> Willd.	<i>Cardaminella</i>	16	Italy (OSBU), 223	FJ464463, FJ464486	FJ464509	FJ464529
<i>C. altigena</i> Schltr. ex O. E. Schulz			Papua New Guinea, Franzke et al., 1998	AF078011, AF078012	AF079343	
<i>C. amara</i> L. subsp. <i>amara</i>	<i>Cardamine</i>	16	Slovakia, Marhold et al., 2004	AY245985, AY246015		
<i>C. amara</i> subsp. <i>amara</i>	<i>Cardamine</i>	16	Italy, Lihova et al., 2004	AY260579		
<i>C. amara</i> subsp. <i>pyrenaea</i> Sennen	<i>Cardamine</i>	16	Spain, Franzke & Hurka, 2000		AF266633	
<i>C. amara</i> subsp. <i>pyrenaea</i>	<i>Cardamine</i>	16	Spain, Lihova et al., 2004	AY260580		
<i>C. amara</i>	<i>Cardamine</i>	16	Norway (O), Wesenberg		EU819147	
<i>C. amporitana</i> Sennen & Pau	<i>Cardamine</i>	32	Spain, Lihova et al., 2004	AY260585		
<i>C. amporitana</i>	<i>Cardamine</i>	32	Italy, Lihova et al., 2004	AY260608		
<i>C. angulata</i> Hook.	<i>Macrophyllum</i>	40	U.S.A., Washington State (MO), Thysell	FJ464464, FJ464487	FJ464522	FJ464545
<i>C. angulata</i>	<i>Macrophyllum</i>	40	U.S.A. (S), Calder, Savile & Taylor		EU819198	EU819240
<i>C. angustata</i> O. E. Schulz	<i>Dentaria</i>	128	U.S.A. (MO), Kral	FJ464465, FJ464488	FJ464520	FJ464542
<i>C. angustata</i>	<i>Dentaria</i>	128	U.S.A., Sweeney & Price, 2000		AF198121	
<i>C. appendiculata</i> Franch. & Sav.	<i>Macrophyllum</i>		Japan (O), H. Ogura	EU819308		
<i>C. arisanensis</i> Hayata			Taiwan (S)	EU819335	EU819199	
<i>C. asarifolia</i> L.	<i>Cardamine</i>	48	Italy, Lihova et al., 2004	AY260620		
<i>C. barbaraeoides</i> Halácsy	<i>Cardamine</i>	32	Greece, Lihova et al., 2004	AY260614		
<i>C. bellidifolia</i> L.	<i>Cardaminella</i>	16	Norway, Sweeney & Price, 2000		AF198122	
<i>C. bellidifolia</i>	<i>Cardaminella</i>	16	Spitsbergen (O), Elven		EU819148	EU819306

APPENDIX 1. Continued.

Species	Section	2n =	Country/Territory (Herbarium) Collector/Determinator ^a	ITS	<i>trnL</i> intron	<i>trnL-F</i> spacer
<i>C. bellidifolia</i>	<i>Cardamine</i>	16	Russia (O), Maksimova	EU819310	EU819149	EU819305
<i>C. bipinnata</i> O. E. Schulz	<i>Dentaria</i>		Russia (WU)	FJ464466, FJ464489	FJ464513	FJ464535
<i>C. blaisdellii</i> Eastw.	<i>Cardamine</i>	28, 42	U.S.A. (O), R. Elven	EU819313	EU819150	EU819301
<i>C. blaisdellii</i>	<i>Cardamine</i>	28, 42	U.S.A. (O), R. Elven	EU819312	EU819151	EU819303
<i>C. bonariensis</i> Pers.	<i>Cardamine</i>		Ecuador (S), I. A. Al-Shehbaz	EU819314	EU819200	EU819241
<i>C. bonariensis</i>	<i>Cardamine</i>		Peru (MO), Duncan			
<i>C. bradei</i> O. E. Schulz	<i>Cardamine</i>		Costa Rica (S), R. L. Liesner	EU819318		
<i>C. breweri</i> S. Watson	<i>Cardamine</i>	84–96	U.S.A. (S), C. L. Porter & M. W. Porter	EU819315	EU819201	
<i>C. breweri</i>	<i>Cardamine</i>	84–96	U.S.A. (GA), Price		AF198123	
<i>C. bulbifera</i> Crantz	<i>Dentaria</i>	96	Germany, Franzke et al., 1998	AF078017, AF078018	AF079346	
<i>C. bulbifera</i>	<i>Dentaria</i>	96	Ukraine (MW)			FJ464534
<i>C. bulbosa</i> (Schreb. ex Muhl.) Britton, Stems & Poggenb.		32–64	U.S.A. (MO), Kral		FJ464524	FJ464546
<i>C. bulbosa</i>		32–64	Canada (S), Gilles Lemieux	EU819316	EU819202	EU819242
<i>C. bulbosa</i>		32–64	U.S.A. (O), B. O. Wolden		EU819153	
<i>C. bulbosa</i>		32–64	U.S.A., Sweeney & Price, 2000		AF198124	
<i>C. californica</i> (Nutt.) Greene	<i>Eutryptophyllum</i>	32	U.S.A. (OSBU), Hurka	FJ464467, FJ464490	FJ464525	FJ464547
<i>C. carnosa</i> Waldst. & Kit.	<i>Pteroneurum</i>		Greece (S), K. H. Rechinger	EU819317	EU819203	EU819243
<i>C. castellana</i> Lihova & Marhold		16	Spain, Lihova et al., 2004	AY260578		
<i>C. chelidonia</i> L.	<i>Spirobolus</i>	64	Italy (O), J. Poelt		EU819154	
<i>C. clematitis</i> Shuttlew. ex S. Watson	<i>Cardamine</i>		U.S.A. (S), Leonard & Radford	EU819318	EU819204	EU819246
<i>C. concatenata</i> (Michx.) O. Schwarz	<i>Dentaria</i>	256	Canada (S), D. E. Swales	EU819319		
<i>C. concatenata</i>	<i>Dentaria</i>	256	Canada (WU)	EU819320		
<i>C. concatenata</i>	<i>Dentaria</i>	256	Canada (WU)		FJ464521	FJ464543
<i>C. conferta</i> Jurtzev		48	Russia (LE), L. Fokina	EU819321	EU819155, EU819156	EU819288, EU819291
<i>C. constancei</i> Detling			U.S.A. (S), R. C. Rollins	EU819322	EU819205	EU819244
<i>C. cordifolia</i> A. Gray	<i>Cardamine</i>	24	U.S.A. (S), Holmgren, Reveal & LaFrance	EU819324	EU819206	EU819245
<i>C. cordifolia</i>	<i>Cardamine</i>	24	U.S.A. (O), Dahl		EU819157	
<i>C. corymbosa</i> Hook. f.	<i>Cardamine</i>	48	Australia, Bleeker et al., 2002	AF078003, AF078004	AF079339	AY047645
<i>C. corymbosa</i>	<i>Cardamine</i>	48	New Zealand, Bleeker et al., 2002	AY047613, AY047624	AY047633	AY047646
<i>C. crassifolia</i> Pourr.		16	Spain, Lihova et al., 2004	AY260605		
<i>C. debilis</i> Banks ex DC.	<i>Cardamine</i>	48	New Zealand, Bleeker et al., 2002	AY047614, AY047625	AY047643	AY047660

APPENDIX 1. Continued.

Species	Section	2n –	Country/Territory (Herbarium) Collector/Determinator ^a	ITS	<i>trnL</i> intron	<i>trnL-F</i> spacer
<i>C. delavayi</i> Franch.			China (MO), 14549	EU819325		EU819248
<i>C. densiflora</i> Gontsch.			Tajikistan (MW)	FJ464468, FJ464491		
<i>C. dentipetala</i> Matsum.			Japan (S), M. Mizushima	EU819326	EU819207	
<i>C. digitata</i> Richardson	<i>Cardamine</i> <i>ella</i>	28, 42	U.S.A. (O), Elven	EU819330	EU819158	
<i>C. digitata</i>	<i>Cardamine</i> <i>ella</i>	28, 42	U.S.A. (O), Elven	EU819329	EU819159	EU819302
<i>C. digitata</i>	<i>Cardamine</i> <i>ella</i>	28, 42	Canada (O), ver. by Elven	EU819327, EU819328	EU819160, EU819161	EU819304, EU819292
<i>C. digitata</i>	<i>Cardamine</i> <i>ella</i>	28, 42	Russia (MW)	FJ464469, FJ464492		
<i>C. digitata</i>	<i>Cardamine</i> <i>ella</i>	28, 42	Russia (MW)		FJ464512	FJ464533
<i>C. diphylla</i> (Michx.) Alph. Wood	<i>Dentaria</i>	96–256	Canada (S), Blondeau	EU819331	EU819208	EU819249
<i>C. dissecta</i> (Leavenw.) Al-Shehbaz	<i>Dentaria</i>		U.S.A. (WU)	FJ464470, FJ464493	FJ464528	FJ464544
<i>C. douglassii</i> Britton		28–72	U.S.A. (S), Hainault	EU819332	EU819209	EU819247
<i>C. douglassii</i>		28–72	Canada (O), Hainault		EU819162	
<i>C. ecuadorensis</i> Hieron.	<i>Cardamine</i>		Ecuador (S), Brekke	EU819333	EU819210	
<i>C. enneaphyllos</i> (L.) Cranz	<i>Dentaria</i>	80	Austria, Kärnten (OSBU), 5182	FJ464471, FJ464494	FJ464515	FJ464537
<i>C. flaccida</i> Cham. & Schltdl.	<i>Cardamine</i>	16	Chile (O), Skottsberg	EU819334		
<i>C. flexuosa</i> With.	<i>Cardamine</i>	32	Germany, Franzke et al., 1998; Bleeker et al., 2002	AF077999, AF077800	AF079337	AY047644
<i>C. fragarifolia</i> O. E. Schulz	<i>Cardamine</i>		China (MO), 317	EU819336		EU819250
<i>C. franchetiana</i> Diels			China (MO), 20021	EU819337		EU819251
<i>C. gallaecica</i> (M. Lainez) Rivas Mart. & Izco		(32) 48	Spain, Lihova et al., 2004	AY260613		
<i>C. glacialis</i> (G. Forst.) DC.	<i>Cardamine</i>	72	Chile, Bleeker et al., 2002	AY047615, AY047626	AY047634	AY047648
<i>C. glacialis</i>	<i>Cardamine</i>	72	Argentina, Bleeker et al., 2002	AY047616, AY047627	AY047635	AY047649
<i>C. glanduligera</i> O. Schwarz	<i>Dentaria</i>	42	Regensburg Botanical Garden (Germany)	EU819338	EU819163	
<i>C. glanduligera</i>	<i>Dentaria</i>		Ukraine (MW)		FJ464518	FJ464540
<i>C. glanduligera</i>	<i>Dentaria</i>		Russia (MW)		FJ464519	FJ464541
<i>C. glauca</i> Spreng.	<i>Pteroneurum</i>	16	Italy (S), Segelberg	EU819211		EU819253
<i>C. graeca</i> L.	<i>Pteroneurum</i>	16–18	Romania (O), Borza & Bujorean		EU819164	
<i>C. griffithii</i> Hook. f. & Thomson	<i>Cardamine</i>		China (MO), 496	EU819339		EU819254
<i>C. heptaphylla</i> (Vill.) O. E. Schulz	<i>Dentaria</i>	48	Italy (OSBU), Bernhardt	FJ464472, FJ464495	EU819212	EU819255
<i>C. hirsuta</i> L.	<i>Cardamine</i>	16	Germany, Franzke et al., 1998	AF077997, AF077998		
<i>C. impatiens</i> L.	<i>Cardamine</i>	16	Germany, Franzke et al., 1998	AF078015, AF078016		
<i>C. impatiens</i>	<i>Cardamine</i>	16	Norway (O), K. Lye		EU819167	

APPENDIX 1. Continued.

Species	Section	2n =	Country/Territory (Herbarium) Collector/Determinator ^a	ITS	<i>trnL</i> intron	<i>trnL-F</i> spacer
<i>C. keysseri</i> O. E. Schulz			New Guinea, Franzke et al., 1998	AF078013, AF078014	AF079344	AY047651
<i>C. kitaibelii</i> Bech.	<i>Dentaria</i>		Bosnia-Herzegovina, (WU)	FJ464473, FJ464496	FJ464516	FJ464538
<i>C. kitaibelii</i>	<i>Dentaria</i>		Switzerland (S), Simon		EU819214	EU819257
<i>C. laciniata</i> (Muhlenb.) Wood	<i>Dentaria</i>		Canada (S), Swales		EU819215	
<i>C. lacustris</i> (Garn.-Jones & P. N. Johnson) Heenan		48	New Zealand, Mitchell & Heenan, 2000	AF100683		
<i>C. leucantha</i> O. E. Schulz	<i>Macrophyllum</i>	16	Japan (S), M. Mizushima		EU819216	EU819260
<i>C. leucantha</i>	<i>Macrophyllum</i>	16	Japan (S), M. Furuse	EU819340		
<i>C. leucantha</i>	<i>Macrophyllum</i>	16	Russia (MW)	FJ464474, FJ464497		
<i>C. lihengiana</i> Al-Shehbaz			China (MO), 1207	EU819342		EU819261
<i>C. lilacina</i> Hook.		48	Australia, Franzke et al., 1998	AF078007, AF078008	AF079341	AY047659
<i>C. lilacina</i>		48	Australia, Franzke et al., 1998	AF078005, AF078006	AF079340	AY047647
<i>C. longii</i> Fernald			U.S.A. (S), Fernald & Long	EU819343	EU819217	EU819262
<i>C. lyallii</i> S. Watson	<i>Cardamine</i>		U.S.A. (S), R. C. Rollins	EU819323		
<i>C. macrophylla</i> Willd.	<i>Macrophyllum</i>	64–96	Japan (MO), Al-Shehbaz	EU819345		EU819263
<i>C. macrophylla</i>	<i>Macrophyllum</i>	64–96	Russia (MW)	FJ464475, FJ464498		
<i>C. matthioli</i> Moretti ex Comolli	<i>Cardamine</i>	16	Slovenia, Lihova et al., 2004	AY260606		
<i>C. matthioli</i>	<i>Cardamine</i>	16	Bulgaria, Franzke & Hurka, 2000		AF266642	
<i>C. matthioli</i>	<i>Cardamine</i>	16	Slovakia, Franzke et al., 1998		AF079330	Af266597
<i>C. microphylla</i> Adams	<i>Cardaminella</i>	28–64	Russia (LE), Tolmachev & Polozova	EU819347	EU819172	
<i>C. microphylla</i>	<i>Cardaminella</i>	28 ^c	Russia (LE), Zhukova	EU819346		
<i>C. microphylla</i>	<i>Cardaminella</i>	28–64	Russia (LE), Tolmachev & Yurtsev		EU819173	EU819290
<i>C. microphylla</i>	<i>Cardaminella</i>	28–64	Russia (O), Plyeva		EU819170	
<i>C. microphylla</i>	<i>Cardaminella</i>	28–64	Russia (MW)			FJ464532
<i>C. microzyga</i> O. E. Schulz	<i>Cardamine</i>		China (S), J. F. Rock	EU819348	EU819220	EU819266
<i>C. nipponica</i> Franch. & Sav.	<i>Cardaminella</i>		Japan (S), M. Tamura, 9141	EU819349		
<i>C. nuttallii</i> Greene	<i>Eutryptophyllum</i>		U.S.A., California (MO), Taylor	EU819350	FJ464523	EU819267
<i>C. obliqua</i> Hochst. ex A. Rich.	<i>Cardamine</i>	36–72	Kenya, Bleeker et al., 2002	AY047617, AY047628	AY047636	AY047652
<i>C. obliqua</i>	<i>Cardamine</i>	36–72	Ethiopia, Bleeker et al., 2002	AY047618, AY047629	AY047638	AY047654
<i>C. obliqua</i>	<i>Cardamine</i>	36–72	Kenya (S), Å. Strid		EU819223	
<i>C. occidentalis</i> (Watson) O. E. Schulz	<i>Cardamine</i>	64	U.S.A. (OSC), 335917	EU819351		EU819269
<i>C. occidentalis</i>	<i>Cardamine</i>	64	U.S.A. (OSC), 357322	EU819352		EU819268
<i>C. ovata</i> Benth.	<i>Papyrophyllum</i>		Ecuador (S), Al-Shehbaz	EU819353	EU819224	
<i>C. ovata</i>	<i>Papyrophyllum</i>		Ecuador (S), Al-Shehbaz		EU819225	

APPENDIX 1. Continued.

Species	Section	2n –	Country/Territory (Herbarium) Collector/Determinator ^a	ITS	<i>trnL</i> intron	<i>trnL-F</i> spacer
<i>C. ovata</i>	<i>Papyrophyllum</i>		Ecuador (MO), Al-Shehbaz			EU819270
<i>C. papuana</i> O. E. Schulz	<i>Papyrophyllum</i>		Papua New Guinea (CANB), 13035	FJ464477, FJ464500		
<i>C. parviflora</i> L.	<i>Cardamine</i>	16	Slovakia (O), Cernoch	EU819354		
<i>C. parviflora</i>	<i>Cardamine</i>	16	Austria (OSBU), Hurka	FJ464478, FJ464501		
<i>C. pattersonii</i> L. F. Hend.			U.S.A. (OSC), 245394	EU819355		EU819271
<i>C. paucijuga</i> Turcz.			Australia, Bleeker et al., 2002	AY047619, AY047630	AY047640	AY047656
<i>C. pedata</i> Regel & Tiling	<i>Cardaminella</i>	30 ^c	Russia (LE), Zhukova, Yurtsev & Petrovsky	EU819356	EU819175, EU819176	EU819276, EU819277
<i>C. pennsylvanica</i> Muhl. ex Willd.		32, 64	U.S.A. (ALA), Duffy		EU819177	
<i>C. pennsylvanica</i>		32, 64	U.S.A. (ALA), De Lapp & Duffy		EU819178	
<i>C. pentaphyllos</i> (L.) Crantz	<i>Dentaria</i>	48	V7030-2003 (Botanical Garden, Natural History Museum of Oslo)	EU819357		
<i>C. penzesii</i> Ančev & Marhold		16	Bulgaria, Franzke & Hurka, 2000		AF266643	AF266600
<i>C. plumieri</i> Vill.	<i>Cardaminella</i>	16	Italy (GAT)	FJ464479, FJ464502		
<i>C. pratensis</i> L.	<i>Cardamine</i>	16–118	Portugal, Marhold et al., 2004	AY245995, AY246025		
<i>C. prorepens</i> Fisch. ex DC.	<i>Cardamine</i>	18, 20	Russia (LE), Yurtsev		EU819179	
<i>C. prorepens</i>	<i>Cardamine</i>	18, 20	Russia (LE), A. P. Arkhangelskaya		EU819180	
<i>C. prorepens</i>	<i>Cardamine</i>	18, 20	Russia (MW)	FJ464480, FJ464503		
<i>C. purpurea</i> Cham. & Schltdl.	<i>Cardaminella</i>	96 ^c	Russia (LE), Petrovsky	EU819362	EU819185	
<i>C. purpurea</i>	<i>Cardaminella</i>	96 ^c	Russia (LE), Petrovsky	EU819363	EU819186	EU819294
<i>C. purpurea</i>	<i>Cardaminella</i>	80	U.S.A. (O), Elven	EU819360	EU819181	
<i>C. purpurea</i>	<i>Cardaminella</i>	80	U.S.A. (O), Elven	EU819361	EU819182	EU819275
<i>C. purpurea</i>	<i>Cardaminella</i>	80	U.S.A. (O), Murray, Yurtsev, Kelso	EU819358	EU819183	EU819293
<i>C. purpurea</i>	<i>Cardaminella</i>	80	U.S.A. (O), Elven & Grundt	EU819359	EU819184	
<i>C. purpurea</i>	<i>Cardaminella</i>	80	Russia (MW)		FJ464511	FJ464531
<i>C. quinquefolia</i> (M. Bieb.) Benth. & Hook. f. ex Schmalh.	<i>Dentaria</i>		Ukraine (MW)	FJ464481, FJ464504	FJ464514	FJ464536
<i>C. resedifolia</i> L.	<i>Cardaminella</i>	16	Austria (S), Emanuelsson	EU819364	EU819228	EU819273
<i>C. resedifolia</i>	<i>Cardaminella</i>	16	Italy (OSBU), 123	FJ464482, FJ464504	FJ464510	FJ464530
<i>C. rhizomata</i> Rollins			Ecuador (S), Al-Shehbaz	EU819365	EU819229	
<i>C. rivularis</i> Schur		16	Romania, Franzke et al., 1998	AF077981, AF077982	AF079328	AF266595
<i>C. rivularis</i>		16	Bulgaria, Franzke & Hurka, 2000	AF265201, AF265181		
<i>C. rockii</i> O. E. Schulz	<i>Cardamine</i>		China (S), Rock	EU819366	EU819230	
<i>C. rotundifolia</i> Michx.	<i>Cardamine</i>		U.S.A. (S), Gilbert	EU819367	EU819231	EU819274

APPENDIX 1. Continued.

Species	Section	2n =	Country/Territory (Herbarium) Collector/Determinator ^a	ITS	trnL intron	trnL-F spacer
<i>C. rupicola</i> (Schulz) Hitch.			U.S.A. (S), Cronquist	EU819368	EU819232	EU819278
<i>C. scutata</i> Thunb.		32	Japan (MO18034)	EU819372		EU819279
<i>C. scutata</i>		32	Taiwan (S), Hsu	EU819370	EU819227	EU819272
<i>C. scutata</i> var. <i>formosana</i> (Hayata) T. S. Liu & S. S. Ying		32	Taiwan, Yang et al., 1999	AF128107		
<i>C. sphenophylla</i> Jurtzev (isotype)	<i>Cardaminella</i>	28 ^c	Russia (LE), Kozhevnikov & Yurtsev	EU819373	EU819187	
<i>C. tanakae</i> Franch. & Sav.	<i>Cardamine</i>		Japan (S), Miyoshi Furuse	EU819374	EU819233	EU819281
<i>C. tanakae</i>	<i>Cardamine</i>		Japan (MO), Kurosawa	EU819375		EU819280
<i>C. tangutorum</i> O. E. Schulz	<i>Dentaria</i>	42	China (S), Schulz	EU819376	EU819234	EU819282
<i>C. tenella</i> (Pursh) O. E. Schulz	<i>Eutiretophyllum</i>		U.S.A. (S), Cronquist		EU819235	
<i>C. tenera</i> S. G. Gmel. ex C. A. Mey.	<i>Cardamine</i>	16	Russia, Marhold et al., 2004	AY245980, AY246010		
<i>C. tenuifolia</i> (Ledeb.) Turcz.	<i>Sphaerotorrhiza</i>	32	Russia (S), Petrovsky & Plieva			EU819283
<i>C. tenuifolia</i>	<i>Sphaerotorrhiza</i>	32	Russia (MW)		FJ464527	FJ464549
<i>C. torrentis</i> Nakai		56	Japan (S), T. Yoshimura		EU819236	
<i>C. torrentis</i>		56	Japan (S), M. Mizushima	EU819377	EU819237	EU819284
<i>C. trichocarpa</i> Hochst. ex A. Rich.	<i>Cardamine</i>	16, 32	Ethiopia, Bleeker et al., 2002	AY047620, AY047631	AY047641	AY047657
<i>C. trichocarpa</i>	<i>Cardamine</i>	16, 32	Tanzania, Bleeker et al., 2002	AY047621, AY047632	AY047637	AY047653
<i>C. trifolia</i> L.	<i>Coriophyllum</i>	16	Austria (OSBU), Bernhardt	FJ464483, FJ464506	FJ464526	FJ464548
<i>C. uliginosa</i> M. Bieb.	<i>Cardamine</i>	16	Georgia, Marhold et al., 2004	AY245981, AY246011		
<i>C. umbellata</i> Greene	<i>Cardaminella</i>	32, 48	U.S.A. (O), Elven	EU819379	EU819189	EU819296
<i>C. umbellata</i>	<i>Cardaminella</i>	32, 48	U.S.A. (O), Elven	EU819380	EU819190	EU819297
<i>C. umbellata</i>	<i>Cardaminella</i>	32, 48	U.S.A. (O), Elven	EU819378	EU819191	EU819295
<i>C. victoris</i> N. Busch	<i>Cardaminella</i>	28 ^c	Russia (LE), Kozhevnikov & Yurtsev	EU819383	EU819195	EU819298
<i>C. victoris</i>	<i>Cardaminella</i>	28 ^c	Russia (LE), Yurtsev & Zhukova	EU819382	EU819194	EU819298
<i>C. victoris</i>	<i>Cardaminella</i>	28 ^c	Russia (LE), Koropkov	EU819381	EU819193	EU819299
<i>C. victoris</i>	<i>Cardaminella</i>	28	Russia (O), ver. by R. Elven		EU819192	
<i>C. waldsteinii</i> Dyer	<i>Dentaria</i>		Bosnia-Herzegovina (WU)	FJ464484, FJ464507	FJ464517	FJ464539
<i>C. waldsteinii</i>	<i>Dentaria</i>		Sweeney & Price, 2000		AF198135	
<i>C. waldsteinii</i>	<i>Dentaria</i>		Austria (S), Teppner		EU819238	
<i>C. waldsteinii</i>	<i>Dentaria</i>		Austria (S), Korb		EU819213	EU819256
<i>C. yezoensis</i> Maxim.	<i>Macrophyllum</i>	32	Russia (MW)	FJ464485, FJ464508		
<i>C. yunnanensis</i> Franch.	<i>Cardamine</i>		China (MO), 12360	EU819384		EU819285

^a Where sequences have been retrieved from GenBank, only country/territory and reference are given.^b This specimen was identified as *Cardamine africana*, but results from our study indicate that this specimen represents a separate taxon, termed *C. sp. aff. africana* L. in this paper.^c Indicates that our voucher for the DNA sample is the same voucher as for the chromosome count. Chromosome counts follow the compilations in Kucera et al. (2005) and Warwick and Al-Shehbaz (2006).

A TAXONOMIC REVISION OF THE *SYRINGA PUBESCENS* COMPLEX (OLEACEAE)¹

Chen Jin-Yong,^{2,3,4} Zhang Zuo-Shuang,³ and
Hong De-Yuan²

ABSTRACT

Over 19 species and numerous infraspecific taxa have been described in the *Syringa pubescens* Turcz. complex (Oleaceae), and the taxonomy of this complex has been controversial. To provide a rational taxonomic revision of the complex, field observations were undertaken across China and 14 populations were sampled. The principal coordinate and principal components analyses and general statistical analysis evaluate the significance of characters for taxonomy. As a result, one species is recognized, with three subspecies: *Syringa pubescens* subsp. *pubescens* Turcz., subspecies *microphylla* (Diels) M. C. Chang & X. L. Chen, and subspecies *patula* (Palib.) M. C. Chang & X. L. Chen. *Syringa meyeri* C. K. Schneid. is treated as a new synonym of *S. pubescens* subsp. *pubescens*, and *S. julianae* C. K. Schneid. and *S. meyeri* var. *spontanea* M. C. Chang as new synonyms of *S. pubescens* subsp. *microphylla*. Lectotypes for *S. microphylla* Diels, *S. dielsiana* C. K. Schneid., and *S. venosa* Nakai are designated here.

Key words: Oleaceae, population sampling, statistics, *Syringa pubescens* complex, *Syringa*, taxonomic revision.

The *Syringa pubescens* Turcz. complex (Oleaceae) belongs to section *Syringa* L. ser. *Pubescentes* (C. K. Schneid.) Lingelsh. (Lingelsheim, 1920; Chang, 1992). It differs from the other species in the series in having purple anthers and verrucose fruits, and is widely distributed in China and the Korean Peninsula.

Turczaninow (1840) briefly described *Syringa pubescens* as new, stating that it grew in the mountains of northern China. From 1900 (Palibin, 1900) to 1990 (Chang & Chen, 1990), more than 17 species and additional infraspecific taxa were described. A total of 19 new species and varieties have so far been described in the complex. The taxonomy of this complex has been controversial. McKelvey (1928) recognized seven species, whereas Chang (1992) and Chang and Green (1996) recognized two species, *S. pubescens* and *S. meyeri* C. K. Schneid. The former species comprises four subspecies: subspecies *pubescens* Turcz., subspecies *patula* (Palib.) M. C. Chang & X. L. Chen, subspecies *julianae* (C. K. Schneid.) M. C. Chang & X. L. Chen, and subspecies *microphylla* (Diels) M. C. Chang & X. L. Chen, which overlap in distribution in China (Chang, 1992). *Syringa pubescens* subsp. *microphylla* includes three varieties: *microphylla*, *flavoanthera* (X. L. Chen) M. C. Chang, and *potaninii* (C. K. Schneid.) P. S. Green & M. C. Chang. *Syringa meyeri* consists of two varieties,

variety *meyerii* and variety *spontanea* M. C. Chang. However, Qin (1998) raised *S. meyeri* var. *spontanea* to specific rank as *S. spontanea* (M. C. Chang) X. K. Qin, considering it to have smaller, suborbicular, and palmately 5-veined leaf blades and densely pubescent branchlets. Therefore, three species, four subspecies, and three varieties are recognized for the *S. pubescens* complex in the most recent literature.

Indumentum on leaf surfaces, inflorescence rachises, and calyces has been frequently used to describe new species in *Syringa*. For instance, Komarov (1901) and Schneider (1910) stated that *S. velutina* Kom. and *S. potaninii* C. K. Schneid. differed from *S. pubescens* in being hairy on both sides of the leaves. Nakai (1913) and Skvortzov and Wang (1955) described *S. palibiniana* Nakai and *S. wulingensis* Skvortzov & W. Wang based on their glabrous leaves, different from *S. velutina*. Other characters used by previous authors have included size of plants, inflorescences, and leaf blades; shape and venation pattern of leaf blades; length of corolla tubes; color of anthers; and position of anther insertion. For example, Chen et al. (1989) described *S. microphylla* var. *flavoanthera* X. L. Chen as new based on its yellow anthers.

Taxonomists have described new taxa based on a limited number of specimens, which caused quite a few superfluous names. For instance, Schneider (1905,

¹The authors are grateful to the National Natural Science Foundation of China (grant 30500036) and the Beijing Administrative Bureau of Landscape Architecture for support. We thank the curators of herbaria A, BM, E, FI, HIB, HNWP, IFP, K, LE, NWFC, P, SDFS, SDNU, SHM, TI, UPS, and WUK for permission to examine the specimens or for specimen loans.

²State Key Laboratory of Systematic and Evolutionary Botany, Institute of Botany, Chinese Academy of Sciences, Xiangshan, Beijing 100093, People's Republic of China. hongdy@ibcas.ac.cn.

³Beijing Botanical Garden, Wofosi Road, Beijing 100093, People's Republic of China.

⁴Graduate School, Chinese Academy of Sciences, Beijing 100039, People's Republic of China.

doi: 10.3417/2006072

1910) described *Syringa dielsiana* C. K. Schneid., *S. potaninii*, and *S. giraldiana* C. K. Schneid. as new from the Qinling Range in Shaanxi Province; these species were later lumped into one taxon by Chang and Chen (1990). New species in *Syringa* have been based on minor differences. For example, Tang (1941) described *S. trichophylla* Tang as new, although it is scarcely different from *S. microphylla* in the denser indumentum on leaves and anther nearer to corolla throat. The objective of the present study is to examine the variation of morphological characters based on field observations, population sampling, and subsequent multivariate analysis, and finally to taxonomically revise the *S. pubescens* complex.

MATERIALS AND METHODS

A total of 14 populations were sampled across China (Table 1). In addition, a large number of herbarium specimens collected from the Korean Peninsula and Inner Mongolia, Liaoning, Hebei, Beijing, Shanxi, Shaanxi, Shandong, Henan, Hubei, Chongqing, Gansu, and Qinghai of China were examined from the following herbaria: A, BM, E, FI, HIB, HNWP, IFP, K, NWFC, P, PE, SDFS, SDNU, SHM, TI, UPS, and WUK. The characters used for the analysis were coded as in Appendix 1.

PRINCIPAL COORDINATE AND PRINCIPAL COMPONENTS ANALYSES

In addition to the 14 populations mentioned above, specimens from the Korean Peninsula were used to represent the Korean population (KOR) and specimens from Hubei and Chongqing to represent another population (OTH). The specimens determined as *Syringa meyeri* were represented as MEY in the analysis. The type specimen and other herbarium specimens were incorporated into the analysis to ensure ca. 10 individuals in each group. The numerical data set was transformed by standardization. By calculating Gower similarity coefficient, the principal coordinate analysis (MVSP 3.0 software; Kovach Computing Service, Anglesey, Wales) was used to plot the individual distributions in the 17 populations or data sets. By using principal components analysis (PCA), the characters contributing mostly to the first three principal components were selected for further variation analysis in order to evaluate their taxonomic value.

CHARACTER VARIATION ANALYSIS

For selected characters, the range, mean value, and standard deviation of each population were calculated to determine whether the morphological

variation was continuous or discontinuous among the populations.

CHARACTER ANALYSIS AND RESULTS

The principal component analysis showed that the first coordinate accounted for 20% of the variation and the next two coordinates, 14% and 8.4%, respectively. The main characters contributing to the first component included the length and width of leaf blades, indumentum on inflorescence rachises and calyces, diameter of corolla throats, and anther position on corolla tubes. The characters including length and shape of corolla tubes (CTS), and distance between anthers and corolla throat contribute mostly to the second component. The third component contributes much less than the first two components.

The characters contributing mostly to the first two principal components and those used by previous authors for describing new taxa are analyzed below.

SIZE OF LEAF BLADES

This is a major character in the PCA. According to our observations, leaf blades varied continuously in size among populations, but they were somewhat larger in populations KOR, DAN, and LIA ($4.4\text{--}8.2 \times 2.5\text{--}5.5$ cm) than in other populations ($1.5\text{--}6 \times 1.1\text{--}3.3$ cm) (Fig. 1A, B). The group comprising KOR, DAN, and LIA corresponds to Green and Chang's (1995) *S. pubescens* subsp. *patula*.

SHAPE OF LEAF BLADES

Shape of leaf blades was converted into the ratio of length to width in our analysis for effective comparison. The character is less important as shown in the PCA, and its variation ranges overlap considerably among populations (Fig. 1C).

INDUMENTUM ON LEAF SURFACES

Because the indumentum is a very variable character, we used five grades to describe it (Appendix 1). The analysis of all population samples and herbarium specimens showed that the leaves in most populations are usually glabrous on the adaxial surface of leaves except in KOR, QIN, OTH, and TIA, which have both glabrous and densely hispidulous forms (Table 2). The abaxial surface of the leaves is usually sparsely pubescent (grade 1 or 2) except in KOR, QIN, OTH, and TIA, which also have densely pubescent forms, and in JIN and SHM, which also have glabrous forms (Table 2). Plants from the Qinling Range of China and the Korean Peninsula tend to

Table 1. The *Syringa pubescens* complex in China. Fourteen populations and three data sets (*) are listed approximately from east to west in China and Korea.

Population code	Population site	Voucher collection	Population size (n)
KOR*	Specimens from the Korean Peninsula	<i>E. H. Wilson 8602</i> , K, PE	15
DAN	Liaoning Prov.: Dandong, Mt. Wulong, sunny slope or semi-shade deciduous forest, 400–600 m	<i>J. Y. Chen 04108</i> , PE	8
LIA	Liaoning Prov.: Mt. Fenghuang; Mt. Qianshan, shady deciduous forest or on the summit, 500–600 m	<i>J. Y. Chen 03246</i> , PE	7
JIN	Liaoning Prov.: Jinzhou, Mt. Dahei, sunny, open thicket at the summit, 400 m	<i>J. Y. Chen 03118</i> , PE	15
WUL	Hebei Prov.: Mt. Wuling, semi-shade forest, 1000–1600 m	<i>J. Y. Chen 03180</i> , PE	17
BAI	Beijing: Mt. Baihua, shady deciduous forest, 1200–1700 m	<i>J. Y. Chen 04135</i> , PE	12
HEN	Shanxi Prov.: Mt. Hengshan, semi-shade deciduous forest or open place at the summit, 1400–2000 m	<i>J. Y. Chen 03208</i> , PE	8
SHM	Shanxi Prov.: Taiyuan, Mt. Tianlong, semi-shade forest verge, 1300 m	<i>J. Y. Chen 04102</i> , PE	3
TAI	Shandong Prov.: Mt. Taishan, sunny, open thicket or forest margin, 1400–1500 m	<i>J. Y. Chen 04207, 04210</i> , PE	4
OTH*	Specimens from Hubei Prov. and Chongqing	<i>Z. E. Zhao 2055</i> , HIB	11
HUA	Shaanxi Prov.: Mt. Huashan, sunny, open slope or semi-shade thicket, 1600–2000 m	<i>J. Y. Chen 03143, 03153</i> , PE	16
QIN	Shaanxi Prov.: Mt. Taibai, shady deciduous forest or forest margin, 1200–1700 m	<i>J. Y. Chen 03021</i> , PE	5
ZHU	Shaanxi Prov.: Zhuque National Forest Park, moist, semi-shade deciduous forest, 1700–1900 m	<i>J. Y. Chen 03158, 03160</i> , PE	11
HUO	Shaanxi Prov.: Ningshan, Huoditang, semi-shade deciduous forest verge, 1900–2000 m	<i>J. Y. Chen 05091</i> , PE	4
TIA	Gansu Prov.: Tianshui, Putaoyuan, dry, sunny, open thicket, 1200 m	<i>J. Y. Chen 04036</i> , PE	10
KON	Gansu Prov.: Mt. Kongtong, shady deciduous forest, 2000 m	<i>J. Y. Chen 03171</i> , PE	6
MEY*	Specimen determined as <i>Syringa meyeri</i>	<i>F. N. Meyer 23032</i> , A	4

have denser indumentum on both sides of the leaves than those from northern China. However, the indumentum density cannot be used to delimit taxa in the complex because of its continuous variation.

LEAF VENATION

The leaf venation of *Syringa* is generally pinnate, although palmate venation has been described in *S. meyeri* and *S. meyeri* var. *spontanea* (Chang & Chen, 1990; Green & Chang, 1995). Having critically examined the type specimen of *S. meyeri*, we found that the basal two pairs of veins do not connect to form palmate venation, although the veins are close (Fig. 2A). Similarly, there are both palmate and pinnate veins in the type specimen of *S. meyeri* var. *spontanea* (Fig. 2B). Meanwhile, a venation similar to that of *S. meyeri* and *S. meyeri* var. *spontanea* frequently exists in the populations from Shandong and Shanxi provinces. Therefore, leaf venation is not a

diagnostic character to differentiate *S. meyeri* and *S. meyeri* var. *spontanea* from the other species.

INDUMENTUM ON INFLORESCENCE RACHISES AND CALYCES

This was an important character as shown in the PCA. The populations KOR, SHM, and HUA have inflorescence rachises varying from glabrous to densely hairy, whereas in DAN, WUL, BAI, and HEN they are mostly glabrous and densely hairy in the remaining populations (Table 2). Similarly, the populations DAN, LIA, WUL, BAI, HEN, and MEY have almost glabrous calyces, TIA has hairy calyces, and the remaining populations have both glabrous and hairy forms (Table 2).

SHAPE OF INFLORESCENCE RACHISES

The shape of inflorescence rachises is difficult to distinguish in practice, especially when inflorescence

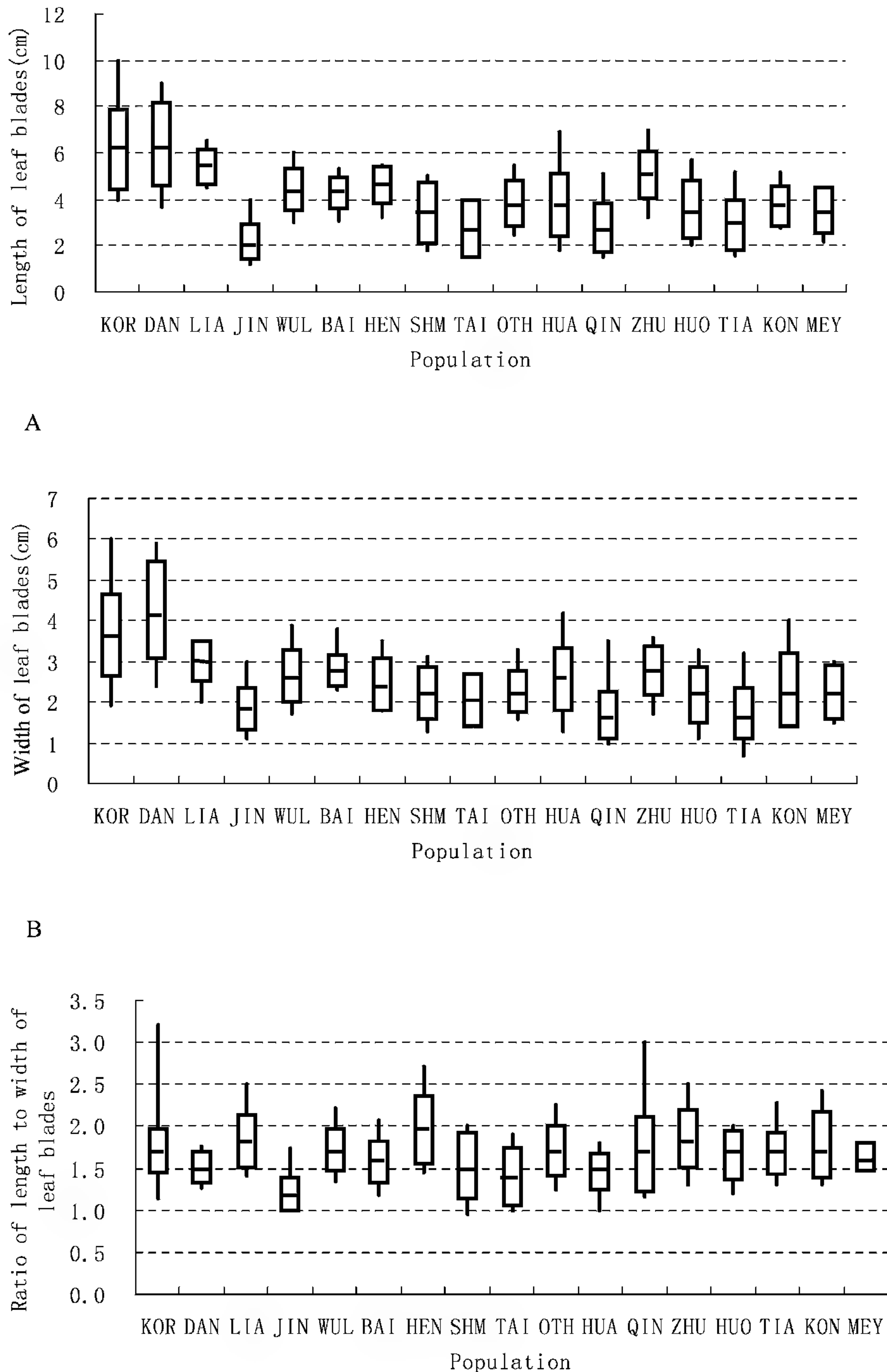

Figure 1. Box plots depicting morphological variability of leaf blades in the *Syringa pubescens* Turcz. complex. —A. Lengths of leaf blades. —B. Widths of leaf blades. —C. Length to width ratios of leaf blades. Character ranges include means and standard deviations. Abbreviations of the 17 populations are explained in Table 1.

Table 2. The number of individuals of each indumentum coverage (see Appendix 1) on leaf surfaces, inflorescence rachises, and calyces among populations of the *Syringa pubescens* complex.

Population	Adaxial leaf surfaces					Abaxial leaf surfaces					Inflorescence rachises					Calyces					
	0	1	2	3	4	0	1	2	3	4	0	1	2	3	4	0	1	2	3	4	
KOR	16	1	4	2	3				17	4	5	8	1	8	6	3	17	1		2	5
DAN	8							7	1			6	2				8				
LIA	9							2	7					4	2	3	6	3			
JIN	18						4	8	6						3	15	3	1		4	10
WUL	19						1	3	15			19					19				
BAI	14							1	13			10	1	2	1		13	1			
HEN	9							5	4			6	1	2			9				
SHM	7	1					2	2	4			4	1			3	5	1		1	1
TAI	18	1					1	7	11			1	3	7	8		13	1	1	4	
OTH	4	6	1	1	1	1	3	6	3			1		3	2	7	8		1	2	2
HUA	18						1	6	10	1		11			2	5	14	1	1	2	
QIN	7	4	4	3	1	1	8	7	3					1	3	15	2	1		3	13
ZHU	8	2							10				3	4	3		7	2	1		
HUO	9						3	6						2	7		4		1	4	
TIA	11	1		3			4	8		3				2	5	8		1	2	5	7
KON	6						1	5						2	3	1	3	2		1	
MEY	4						1	3						3		1	4				

rachises are hairy. From our observations, inflorescence rachises are obviously 4-angled in the populations DAN, LIA, BAI, WUL, HEN, and SHM, and are 4-angled, terete or subterete in the remaining populations.

SHAPE OF COROLLA TUBES

The shape of the corolla tube is quite subjective. We used an alternative method in the analysis so that different populations could be compared. First, we measured the diameter of corolla throats, which varied from 1.6 to 2.5 mm in the populations KOR, DAN, and LIA, 0.9–1.6 mm in JIN, SHM, TAI, QIN, HUO, and TIA, and 1.3–2.2 mm in the others (Fig. 3A). Then we calculated the ratio CTS (Appendix 1), which varied from 0.12 to 0.21 in the populations KOR, DAN, and LIA, and less than 0.12 in the others (Fig. 3B). Therefore, the populations KOR, DAN, and LIA are quite distinctive in the complex.

COLOR OF ANTHERS

AntHERS are usually purple in this complex. Our extensive examination found only three collections with yellow anthers, i.e., *G. Giraldi* 740 (FI), *T. N. Liou* 190 (IFP), and *S. patula* cultivated in Beijing Botanical Garden, which has both yellow and purple anthers on the same individual. Thus, we assume that yellow anthers are occasionally variant and not a good character for the taxonomy of this complex.

ANTHER INSERTION ON THE COROLLA TUBE

From our observations, the distance between anthers and corolla throat is less than 1 mm in the populations KOR, DAN, LIA, OTH, ZHU, and HUO, more than 1 mm in JIN, WUL, BAI, HEN, SHM, HUA, and KON, and 0.4–2 mm in TAI, QIN, and TIA, showing continuous variation among the populations (Fig. 3C). Therefore, the distance between anthers and corolla throat is not effective for delimiting taxa.

CAPSULES

The capsule apices in many populations (DAN, LIA, JIN, WUL, HEN, OTH, HUA, ZHU) are both obtuse and acute, although mostly acute. Thus, the capsule apex is insignificant in the taxonomy of the complex.

The results of principal coordinate analysis (PCO), PCA, and character variation analysis all indicate that only one species can be recognized in the complex, since there are no obvious gaps among the populations in the PCO plot (Fig. 4) and no character shows discrete variation among the populations. However, three entities can be recognized in this complex. It can be seen from the first two coordinates (Fig. 4) that the populations KOR, DAN, and LIA form a loose group, WUL, BAI, and HEN form a second, JIN, QIN, and TIA form a third, while the others (including TAI, HUO, KON, and MEY) are intermediate. Specimens especially from SHM, HUA, ZHU, and OTH are scattered among the above three groups.



Figure 2. —A. *Syringa meyeri* C. K. Schneid., *F. N. Meyer* 23032 (holotype, A). —B. *Syringa meyeri* var. *spontanea* M. C. Chang, *J. Y. Chen* 03121 (PE), collected from the type locality (Jinzhou, Liaoning Province). Note that the leaf venation is not exactly palmate (see arrows).

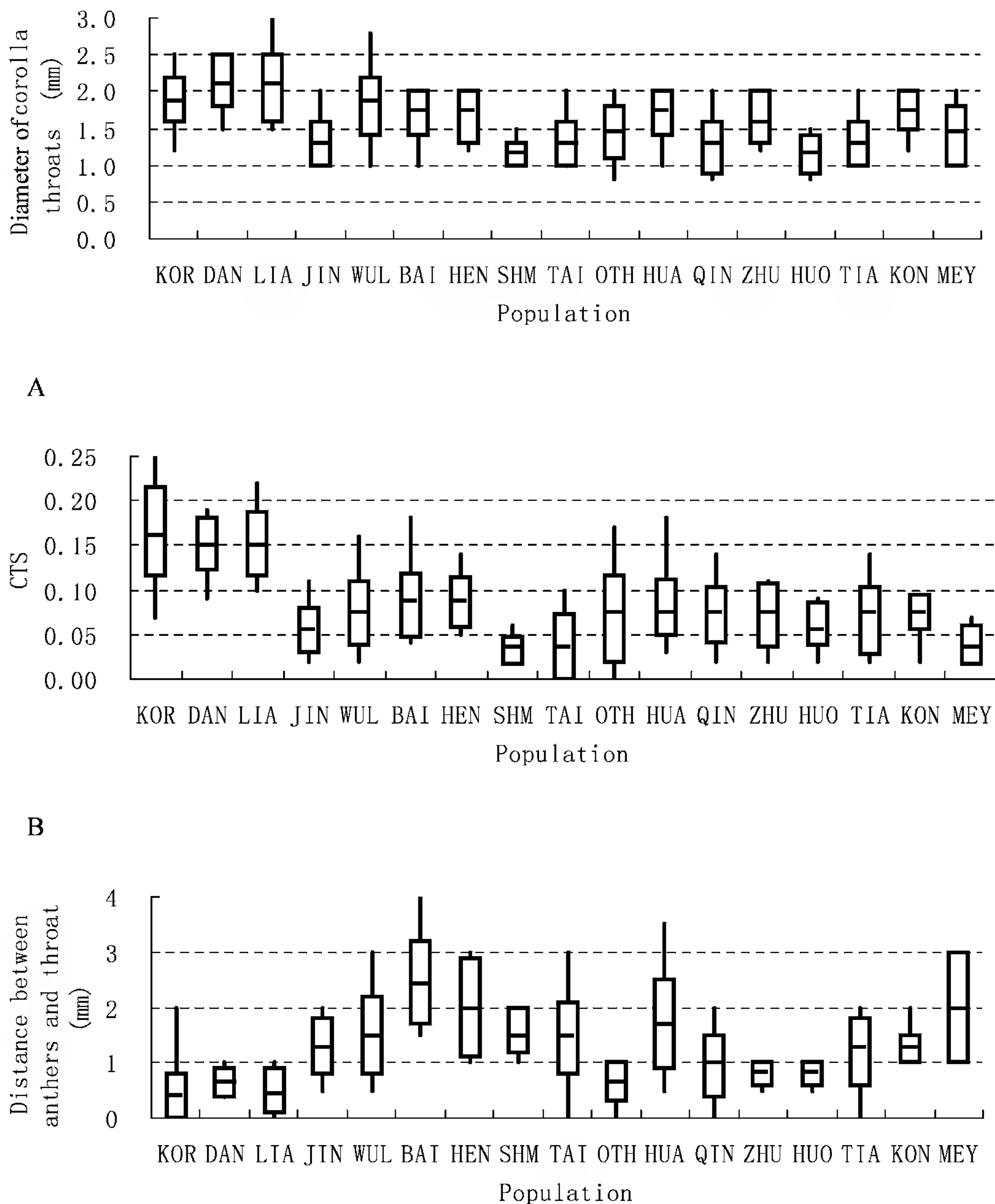

Figure 3. Box plots depicting morphological variability of corollas in the *Syringa pubescens* Turcz. complex. —A. Diameter of corolla throats. —B. Shape of corolla tubes (CTS), expressed as [(diameter of corolla throat – diameter of corolla base) / length of corolla tube]. —C. Comparison of distance between anthers and corolla throat. Character ranges include means and standard deviations. Abbreviations of the 17 populations are explained in Table 1.

Because the populations SHM and HUA show a gradual transition from the third group to the second in the PCO plot, we chose all the specimens from these regions and depicted various characters and altitudes on the plot to see the relationship between

altitudes and characters (Fig. 5). It is shown that the shape and indumentum of inflorescence rachises and the length of leaf blades are related to altitudes in both regions. In the population HUA, plants above 1800 m have inflorescence rachises 4-angled and

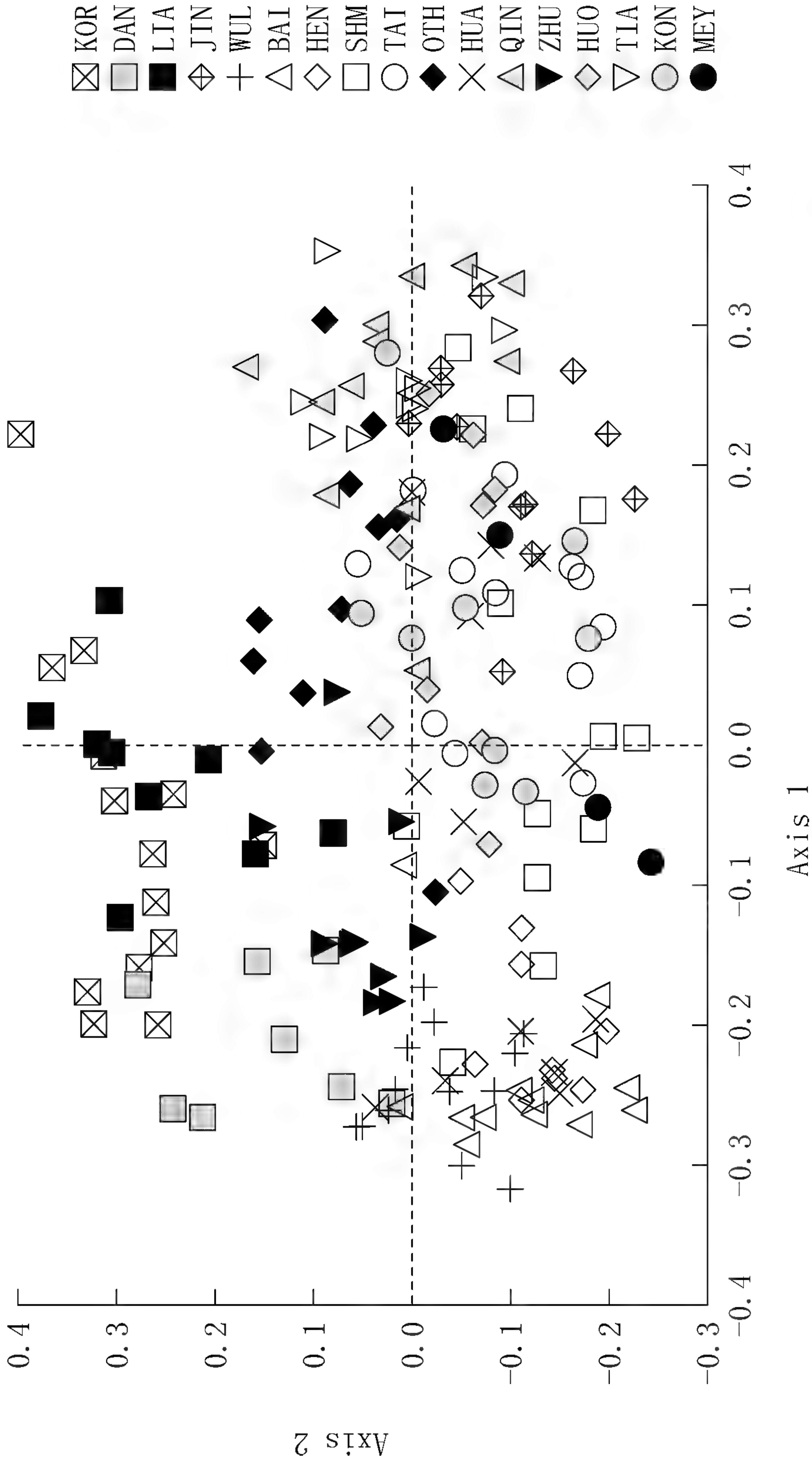

Figure 4. Scatter plot of principal coordinates 1 against 2 for the *Syringa pubescens* complex. Characters contributing to axis 1 include indumentum on inflorescence rachises and calyces. The length and shape of corolla tube and the distance between anthers and corolla throat contribute to axis 2.

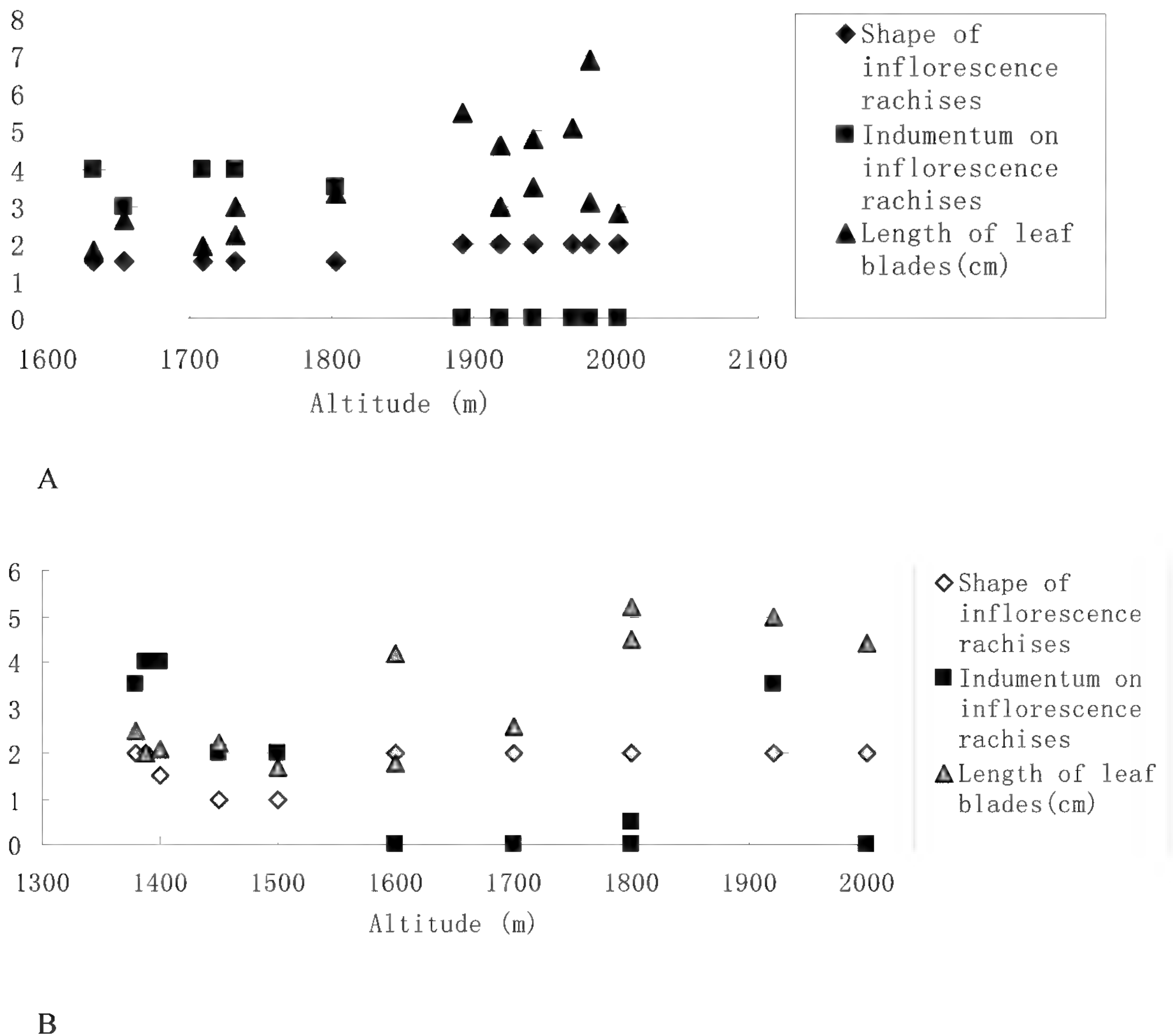

Figure 5. Scatter plots of morphological character against elevational change. —A. Leaf blade length, shape, and the pubescence of the inflorescence rachis (y axis) are plotted against elevational change (x axis) on Mt. Huashan, Shaanxi Province, China (HUA). —B. Morphological characters as in A (y axis) are plotted against elevational change (x axis) for localities in central and southern Shanxi Province in China.

glabrous and leaf blades often more than 3 cm long, whereas those below 1800 m have inflorescence rachises subterete and hairy and leaf blades commonly less than 3 cm long (Fig. 5A). In the population SHM (here the population was enlarged, including *exsiccatae* from central and southern Shanxi Province), plants from 1600 m and up have inflorescence rachises almost glabrous and 4-angled and leaf blades usually more than 4 cm long, while those below 1600 m tend to have inflorescence rachises hairy and subterete and leaf blades less than 3 cm long (Fig. 5B). The results indicate that plants from higher altitudes of eastern Shaanxi (HUA) and southern and central Shanxi (SHM) resemble plants from northern China (WUL, BAI, HEN), whereas those from lower altitudes resemble plants from western China (KON, TIA, QIN, etc.)

Therefore, three subspecies are recognized in the complex. The first subspecies includes the populations KOR, LIA, and DAN, which have leaf blades usually 4.4–8.2 cm long, corolla tubes funnel-shaped (CTS greater than 0.12), and throats usually 1.6–2.5 mm in diameter. These characteristics are in accordance with those of Chang and Chen’s (1990) subspecies *patula*. This subspecies is distributed in the Korean Peninsula and northeastern China (Fig. 6). The second includes the populations WUL, BAI, HEN, and the high-altitude specimens from the populations SHM and HUA, which have inflorescence rachises 4-angled and glabrous and leaves generally 3.5–5.4 cm long. This corresponds to subspecies *pubescens*. It occurs in Inner Mongolia, Beijing, Hebei, northern Shanxi, and at higher altitudes in central and southern Shanxi and eastern Shaanxi

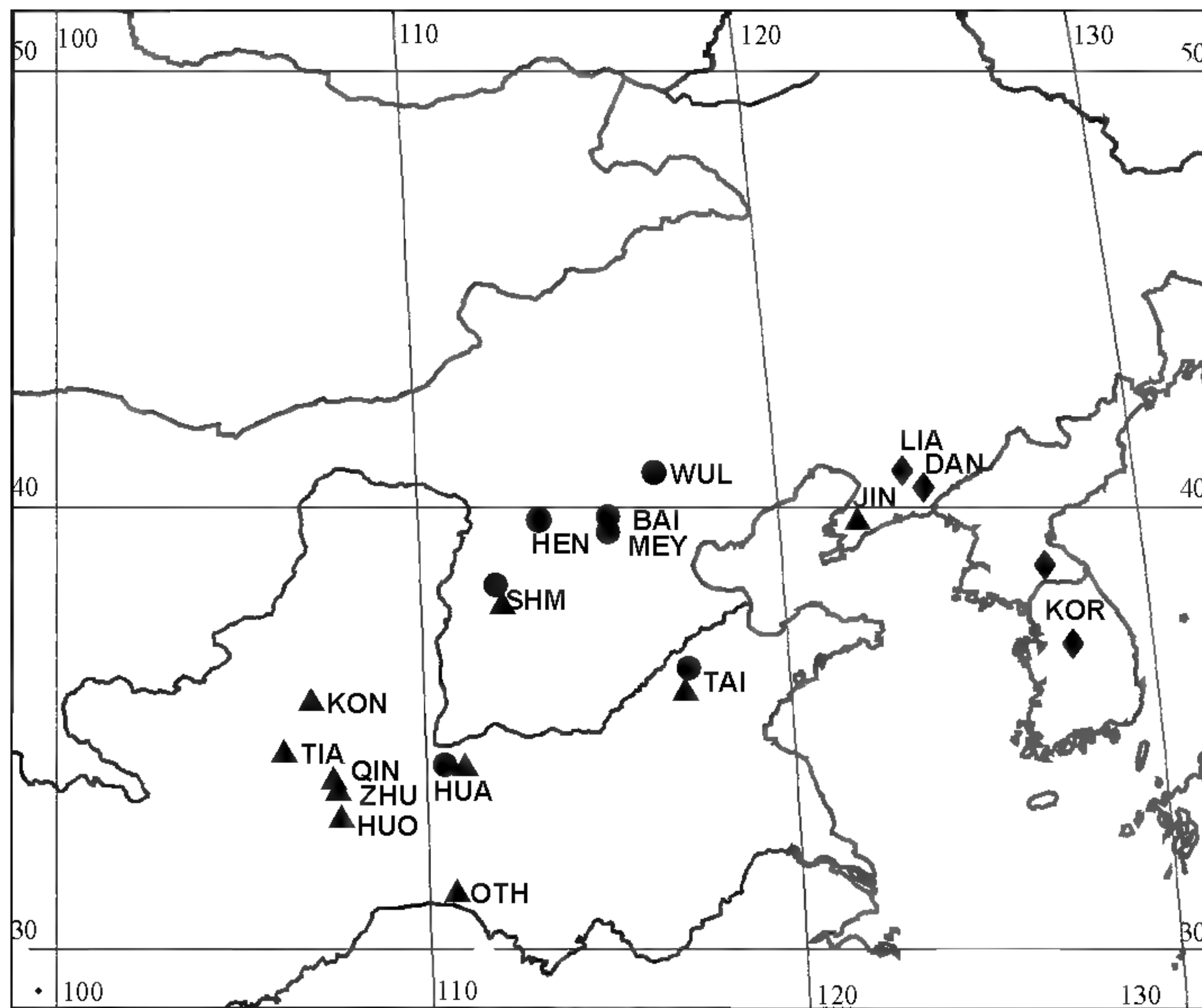

Figure 6. Distribution map of the 17 populations of the *Syringa pubescens* complex. Filled circle, subsp. *pubescens*; filled triangle, subsp. *microphylla*; filled diamond, subsp. *patula*.

provinces (Fig. 6). The third comprises the remaining populations, which have hairy, subterete or 4-angled inflorescence rachises, and usually 1.5–6 cm long leaf blades. The subspecies *microphylla* includes Chang and Chen's (1990) subspecies *microphylla* and subspecies *julianae* and Chang's (1990) *S. meyeri* var. *spontanea*. It grows at lower altitudes in central and southern Shanxi and in Shaanxi, as well as in Gansu, eastern Qinghai, Chongqing, western Hubei and Henan, Mt. Taishan of Shandong Province, and the Jinzhou region of Liaoning Province (Fig. 6).

Western Hubei is the type locality of *Syringa julianae*. Plants corresponding to descriptions of *S. julianae* are very rare in the wild and were not found in our fieldwork. Most specimens from this region (population OTH) are close to subspecies *microphylla* in the PCO plot (Fig. 4) except three sheets of *E. H. Wilson 2024*. Thus, plants from this region are still recognized as subspecies *microphylla* even though some extremes occur.

The population JIN was recognized as *Syringa meyeri* var. *spontanea* by Chang (1990) because its venation was close to that of *S. meyeri*. According to our extensive observation, the venation in the population JIN is not always palmate. The basal lateral veins are often close and do not always run parallel to the tip (Fig. 2B). Similar venation patterns frequently appear in the populations TAI, SHM, and TIA. Furthermore, the population JIN is closely allied to the populations TAI, TIA, and QIN in the PCO plot (Fig. 4). Therefore the population JIN is here included in subspecies *microphylla*.

Because *Syringa meyeri* was described from a cultivated plant in Beijing, we chose the type specimen, two specimens determined as *S. meyeri* by M. C. Chang (PE), and a cultivated plant from Beijing Botanical Garden as population MEY for analysis. In the PCO plot (Fig. 4), the type specimen of *S. meyeri* is closer to *S. pubescens* subsp. *pubescens* (BAI, HEN), while the two specimens from PE have closer relationships with subspecies *microphylla*. Because no distinct characters can delimit *S. meyeri* from the others, we treat *S. meyeri* as a new synonym of *S. pubescens* subsp. *pubescens*.

TAXONOMIC TREATMENT

Three subspecies are recognized in *Syringa pubescens*: subspecies *pubescens*, subspecies *microphylla*, and subspecies *patula*.

1. ***Syringa pubescens*** Turcz., Bull. Soc. Imp. Naturalistes Moscou 13: 73. 1840. TYPE: China. Hebei Prov.: 1831, *P. J. Kirilov s.n.* (holotype, LE!, photo PE!).

Leaves 1.2–10 × 0.7–6 cm, glabrous or pubescent, lateral veins in 3 to 5 pairs; petioles 0.3–1.5 cm. Panicles lateral; inflorescence rachises 4-angled or terete, glabrous or pubescent. Calyces glabrous or pubescent; corolla tubes cylindrical or funnel-shaped, 4.5–16 mm, corolla throats 0.8–3 mm wide; anthers purple or rarely yellow, 0–4 mm below corolla throat. Capsules 6–20 × 2–6 mm, verrucose.

Syringa pubescens is distributed on the Korean Peninsula and in China. The taxon typically flowers in May. Chromosome number $2n = 46, 48$.

KEY TO THE THREE SUBSPECIES OF *SYRINGA PUBESCENS*

- 1a. Corolla tube funnel-shaped with corolla throat (1.2–) 1.6–2.5(–3) mm diam.; leaf blades (3.7–) 4.4–8.2(–10) cm long subsp. *patula*
- 1b. Corolla tube cylindrical with corolla throat (0.8–) 0.9–2(–2.8) mm diam.; leaf blades (1.2–) 1.5–6(–7) cm long.
- 2a. Inflorescence rachises glabrous or rarely pubescent, obviously 4-angled; leaf blades usually (3–) 3.5–5.4 (–6) cm long subsp. *pubescens*
- 2b. Inflorescence rachises pubescent, faintly 4-angled or subterete; leaf blades usually (1.2–) 1.5–6(–7) cm long subsp. *microphylla*

1a. *Syringa pubescens* subsp. *pubescens*

Syringa meyeri C. K. Schneid., Pl. Wilson. (Sargent) 1: 301. 1912. Syn. nov. TYPE: China. Beijing: Fengtai in cultivation, June 1910, *F. N. Meyer 23032* (holotype, A!).

Syringa wulingensis Skvortsov & W. Wang, Ill. Fl. Ligneous Pl. N. E. China: 566. 1955. TYPE: China. Hebei Prov.: Mt. Wulingshan, 4 Sep. 1952, *T. N. Liou 4737* (holotype, IFP!).

Leaves $3\text{--}6 \times 1.7\text{--}4.2$ cm, glabrous adaxially, glabrous or sparsely pubescent abaxially, veins pinnate or somewhat acrodromous. Inflorescence rachises obviously 4-angled, glabrous or rarely pubescent; calyces glabrous; corolla tubes cylindrical, 7–16.5 mm, throats 1–2.8 mm wide; anthers 0.5–4 mm below corolla throat.

Distribution and habitat. Subspecies *pubescens* is distributed in Nei Mongol (Inner Mongolia), Beijing, Hebei, Shanxi, Shaanxi, Henan, and Shandong in China. It usually grows in semi-shaded, moist deciduous forests, commonly at high altitudes up to 2400 m.

Discussion. *Syringa meyeri* was described by Schneider (1913) as new, and was stated to differ from *S. pubescens* in having two pairs of lateral veins running to the leaf tip. Green and Chang (1995) further described *S. meyeri* with two pairs of veins more or less palmately arranged at the base. But our careful observation showed that venation in *S. meyeri* was not distinguished from that in *S. pubescens* subsp. *pubescens* (Fig. 2A). Furthermore, no distinct characters differentiate the two taxa. We propose that *S. meyeri* is only an extreme cultivated variety in *S. pubescens* subsp. *pubescens* because *S. meyeri* was described from a cultivated plant in Beijing and no wild plants have been found so far.

Representative specimens examined. CHINA. **Beijing:** Mentougou, Baihuashan, *T. F. King 70* (PE); Miyun, *Ecology*

group 810 (PE). **Hebei:** Chicheng, *s. coll. 4164* (PE); Laishui, *K. M. Liou 2199* (PE); Laiyuan, *K. M. Liou 2367* (PE); Neiqiu, *X. Y. Liu 158* (PE); Wanping, *C. G. Yang 1261* (PE); Wu'an, *K. C. Kuan 5790* (PE); Xinglong, Wulingshan, *T. N. Liou 4779, 6633* (PE); Yixian, Yunmengshan, *K. M. Liou 2094* (PE); Yuxian, Xiaowutaishan, *H. W. Kung 51* (PE); Zhuolu, Xilingshan, *C. G. Yang 847* (PE); Zunhua, Dongling, *T. Tang 1773* (PE). **Henan:** Linbao, *Puchabiaooben 14261, 14632* (PE); Lushi, Laojunshan, *K. M. Liou 5047* (PE); Songxian, Wumasi, *Henandui 1505* (PE); Xixia, Laojunshan, *K. C. Kuan & T. L. Dai 1584* (PE). **Nei Mongol (Inner Mongolia):** *A. David 1797* (K, P), s.d., *P. Arteselaer s.n.* (K). **Shaanxi:** Huayin, Huashan, *J. Y. Chen 03149, 03157* (PE), *W. Y. Hsia 4230* (PE), *T. N. Liou 10833* (PE), *Z. B. Wang 19646* (PE); Chang'an, Gangou, *B. Z. Guo 1108* (PE). **Shandong:** Tai'an, Taishan, *J. Y. Chen 04210, 04211* (PE), *Zhongdedui 674* (PE). **Shanxi:** Huoxian, Huoyueshan, *T. P. Wang 2583* (PE), Lingkongshan, *K. C. Kuan & Y. L. Chen 310* (PE), Qiliyu, *Yellow River Exped. 785* (PE); Hunyuan, Hengshan, *J. Y. Chen 03207, 03214* (PE), *Y. W. Tsui 2556* (PE); Qingyuan, Paoquan, *K. M. Liou 7801* (PE); Wutai, Erdaohe, *K. C. Kuan & Y. L. Chen 1653* (PE), Wutaishan, *D. Zheng 2073* (PE); Xiegan, Xuehuashan, *Yellow River Exped. 407* (PE); Yuanqu, Huangguman, *S. Y. Bao 2231* (PE).

1b. *Syringa pubescens* subsp. *microphylla* (Diels) M. C. Chang & X. L. Chen, Invest. Stud. Nat. 10: 34. 1990. Basionym: *Syringa microphylla* Diels, Bot. Jahrb. Syst. 29: 531. 1901. TYPE: China. Shaanxi: Tui kio shan, Lao yu he, Oct. 1896, *G. Giralddi 1644* (lectotype, designated here, FI!).

Syringa microphylla var. *flavoanthera* X. L. Chen, Bull. Bot. Res., Harbin 9(3): 41. 1989. *Syringa pubescens* subsp. *microphylla* var. *flavoanthera* (X. L. Chen) M. C. Chang, Fl. Reipubl. Popularis Sin. 61: 68. 1992. TYPE: China. Shaanxi: Foping, Longcaoping, 1900 m, s.d., *X. L. Chen 0035* (holotype, NWFC not seen).

Syringa microphylla var. *glabriuscula* C. K. Schneid., Pl. Wilson. (Sargent) 1: 301. 1913. TYPE: China. Hubei: Mt. Miao-uan-san, 1898, *H. Scallan s.n.* (holotype, A not seen).

Syringa pubescens var. *tibetica* Batalin, Trudy Imp. S.-Peterburgsk. Bot. Sada 13 (18): 378. 1894. TYPE: China. Gansu: Huidui, 7200 ft., 7 May 1885, *G. N. Potanin s.n.* (holotype, LE not seen).

Syringa dielsiana C. K. Schneid., Bot. Jahrb. Syst. 36(5, Beibl. 82): 88. 1905. TYPE: China. Shaanxi: Qin ling, 10 June 1900, *G. Giralddi 7193* (lectotype, designated here, FI!).

Syringa giraldiana C. K. Schneid., Bot. Jahrb. Syst. 36(5, Beibl. 82): 88. 1905. *Syringa microphylla* var. *giraldiana* (C. K. Schneid.) S. Z. Qu & X. L. Chen, Bull. Bot. Res., Harbin 9(3): 41. 1989. TYPE: China. Shaanxi: Liu siu shan, Aug. 1899, *G. Giralddi 4405* (holotype, FI!).

Syringa potaninii C. K. Schneid., Repert. Spec. Nov. Regni Veg. 9: 80. 1910. *Syringa pubescens* subsp. *microphylla* var. *potaninii* (C. K. Schneid.) P. S. Green & M. C. Chang, Novon 5: 332. 1995. TYPE: China. Gansu: Tschilo ku, 18 June 1885, *G. N. Potanin s.n.* (holotype, LE!, photo PE!).

Syringa julianae C. K. Schneid., Ill. Handb. Laubholz. 2: 777. 1911. Syn. nov. *Syringa pubescens* subsp. *julianae* (C. K. Schneid.) M. C. Chang & X. L. Chen, Invest. Stud. Nat. 10: 34. 1990. TYPE: China. Hubei: Fangxian, 26 May 1911, *E. H. Wilson 1220A* (holotype, K!).

Syringa verrucosa C. K. Schneid., Pl. Wilson. (Sargent): 1: 298. 1912. TYPE: China. Hubei: Xingshan Co., Mt. Wentsao, 2300 m, 5 June 1907, *E. H. Wilson 2579* (holotype, A not seen; isotype, K!).

Syringa schneideri Lingelsh., Pflanzenr. (Engler) 72 (IV 243): 86. 1920. TYPE: China. Hubei: June 1907, *E. H. Wilson 2024* (holotype, K!; isotype, E!).

Syringa trichophylla Tang, Bull. Fan. Mem. Inst. Biol. Bot. 10: 287. 1941. TYPE: China. Shanxi: Taigu, Fengshan, 400 m, 11 May 1929, *T. Tang s.n.* (holotype, A not seen).

Syringa meyeri var. *spontanea* M. C. Chang, Invest. Stud. Nat. 10: 33. 1990. Syn. nov. *Syringa spontanea* (M. C. Chang) X. K. Qin, Acta Phytotax. Sin. 36(4): 362. 1998. TYPE: China. Liaoning: Jinzhou, Heshang shan (Dahei shan), 500 m, 12 Sep. 1989, *M. C. Chang & X. K. Qin 12872* (holotype, SHM!, photos K!, PE!).

Leaves 1.2–7 × 0.7–4 cm, glabrous or pubescent. Inflorescence rachises pubescent, 4-angled or subterete. Calyces pubescent or glabrous; corolla tubes 4.5–14 mm, throats 0.8–2 mm wide; anthers purple or rarely yellow, 0–3 mm below corolla throat.

Distribution and habitat. *Syringa pubescens* subsp. *microphylla* is distributed in Qinghai, Gansu, Shaanxi, Chongqing, Hubei, Shanxi, Henan, Shandong, and Liaoning provinces. It usually occurs in dry, open scrub or at the margins of semi-shade forest and commonly grows at lower altitudes than subspecies *pubescens*.

Discussion. Two lectotypes were designated here. Diels (1901) described *Syringa microphylla* as new and cited two specimens, *G. Giraldi 1644* and *1645*, both of which were from Tui kio shan of Shaanxi Province. We chose *G. Giraldi 1644* as the lectotype here. Schneider (1905) described *S. dielsiana* as new and cited two specimens, *G. Giraldi 7193* (with flowers) and *741* (with fruit) from Shaanxi Province. We selected the flowering specimen as the lectotype here.

Syringa julianae was described by Schneider (1911) based on a specimen from Hubei Province, which was treated as *S. pubescens* subsp. *julianae* by Chang and Chen (1990). In the PCO plot (Fig. 4), most specimens from the region of the type locality (OTH) are close to those in *S. pubescens* subsp. *microphylla*. The characters previously used to delimit *S. julianae*, such as the shape of the corolla tubes and anther insertion on corolla tubes, are not discrete in the analysis. Thus, *S. julianae* is newly placed in synonymy with *S. pubescens* subsp. *microphylla*.

Syringa meyeri var. *spontanea* was described by Chang and Chen (1990) on the basis of its venation

being similar to that of *S. meyeri*. Qin (1998) even treated it as a separate species, *S. spontanea*, based on its palmate venation. According to our extensive observation, the venation in *S. meyeri* var. *spontanea* is not always palmate. Both palmate and pinnate venations were observed in the type locality (JIN), even in the type specimen (Fig. 2B). Similar venation patterns were observed in Mt. Tianlong (SHM) and Mt. Tai (TAI). Thus, it is not reliable to establish the new taxon based on the venation. *Syringa meyeri* var. *spontanea* resembles *S. pubescens* subsp. *microphylla* in the size and shape of the leaf blades and in the indumentum on the inflorescence rachises and calyces. Breeding experiments in Beijing Botanical Garden showed that *S. meyeri* var. *spontanea* and *S. pubescens* subsp. *microphylla* are interfertile, indicating their close affinity. Therefore, *S. meyeri* var. *spontanea* is here included as a synonym of *S. pubescens* subsp. *microphylla*, which is in accordance with the PCO plot (Fig. 4).

Representative specimens examined. CHINA. **Chongqing:** Chengkou, *P. G. Farges 885* (K). **Gansu:** Pingliang, Kongtongshan, *J. Y. Chen 03171, 03175* (PE); Tianshui, Guanyinya, *Q. S. Li 260* (PE), Putaoyuan, *J. Y. Chen 04035, 04044* (PE), Xiaolongshan, *Yellow River Exped. 3657* (PE); Wushan, Laojunshan, *Yellow River Exped. 4187* (PE). **Henan:** Dengfeng, *s. coll. 51644* (PE); Songxian, Xizhuanghe, *Henan Linyeting 853, 857* (PE); Xixia, Funiushan, *Henan Linyeting 1376* (PE), Laocangling, *K. C. Kuan & T. L. Dai 1148* (PE); Yichuan, *Puchabiaoeben 20296, 21100* (PE). **Hubei:** Badong, *A. Henry 6985* (K); Shiyan, Saiwudang, *Z. E. Zhao 2055* (HIB); Yunxi, Tianfengshan, *J. X. Yang 2540* (PE). **Liaoning:** Jinzhou, *M. C. Chang & X. K. Qin 12878* (K, SHM), *J. Y. Chen 03117, 03129* (PE), *T. N. Liou 192* (IFP). **Qinghai:** Huzhu, *S. P. Wang 041* (HNWP); Minhe, Gushan, *B. Z. Guo & B. W. Li 8461* (HNWP); Xiji, Huoshizhai, *L. H. Zhou 2888* (HNWP). **Shaanxi:** Chang'an, Cuihuashan, *Gansu Yifendui 39* (PE), Nanwutai, *T. N. Liou 199, 11050* (PE); Huayin, Huashan, *J. Y. Chen 03143, 03144* (PE); Huxian, Laoyu, *J. Y. Chen 03041* (PE), Zhuque, *J. Y. Chen 03159, 03167* (PE); Foping, Laojunling, *B. Z. Guo 1408* (PE); Ningshan, Huoditang, *J. Y. Chen 05090, 05095* (PE); Shangxian, Heishanjie, *T. P. Wang 16069* (PE); Shanyang, Xiaohekou, *Z. Y. Zhang 15953* (PE), Yugang gongshe, *J. X. Yang & Y. M. Liang 2807, 2847* (PE); Taibaishan, Dadian, *Y. Y. Pai 1579* (PE), Haopingsi, *J. X. Yang 206* (PE), *J. Y. Chen 03022, 03024* (PE), Jiaolongsi, *J. X. Yang 281, 285* (PE), Liujiacun, *K. T. Fu 82, 2458* (PE), Xiabaiyun, *J. X. Yang 154* (PE). **Shandong:** Tai'an, Taishan, *J. Y. Chen 04207, 04209* (PE), *Shandong Agriculture University 818* (PE), *X. S. Wen 890064* (SDNU), *Zhongdedui 674* (PE). **Shanxi:** Huoxian, Qiliyu, *Yellow River Exped. 702* (PE); Linchuan, *K. M. Liou 7667* (PE); Qingyuan, Paoquan, *K. M. Liou 1391* (PE); Ruicheng, Baiquancun, *S. Y. Bao 544* (PE); Taiyuan, *J. Y. Chen 04101, 04102* (PE), Huyancun, *Y. Yabe s.n.* (PE); Xiegan, Xuehuashan, *Yellow River Exped. 585* (PE); Yicheng, *X. Y. Liu 20370* (PE); Yongji, *T. W. Liu 0038, 0221* (PE); Yuanqu, Tongshan township, *S. Y. Bao 66* (PE).

1c. *Syringa pubescens* subsp. *patula* (Palib.)
M. C. Chang & X. L. Chen, Invest. Stud.

Nat. 10: 34. 1990. Basionym: *Ligustrum patulum* Palib., Trudy Imp. S.-Peterburgsk. Bot. Sada 18(2): 156. 1900. *Syringa patula* (Palib.) Nakai, J. Jap. Bot. 14: 638. 1938. TYPE: Korea. Kyong-Kwi, Seoul prope Tap-Tong, 20 May 1895, A. Sontag s.n. (holotype, LE not seen).

Syringa velutina Kom., Trudy Imp. S.-Peterburgsk. Bot. Sada 18(6): 428. 1901. TYPE: Korea. Musang, Kosari-pi valley, 22 May 1897, V. L. Komarov 1259 (holotype, LE not seen; isotypes, K!, FI!).

Syringa koehneana C. K. Schneid., Ill. Handb. Laubholz. 2: 1063, fig. 627. 1912. TYPE: Fig. 627 in Schneider, 1912: 1063.

Syringa palibiniana Nakai, Bot. Mag. (Tokyo) 27: 32. 1913. TYPE: Korea. s. loc., Sep. 1901, U. Faurie s.n. (holotype, TI not seen).

Syringa micrantha Nakai, Bot. Mag. (Tokyo) 32: 129. 1918. TYPE: Korea. Kosuiin, 23 June 1917, M. Furumi 65 (holotype, TI not seen).

Syringa kamibayashii Nakai, Bot. Mag. (Tokyo) 32: 130. 1918. TYPE: Korea. Dohosan, s.d., K. Kamibayashi s.n. (holotype, TI not seen).

Syringa venosa Nakai, Bot. Mag. (Tokyo) 32: 130. 1918. TYPE: Korea. Ooryongto, 3 June 1917, T. Nakai 4194 (lectotype, designated here, TI!).

Syringa debelderorum J. L. Fiala, Lilacs, Gen. Syringa: 48. 1988, as *S. debelderi*. *Syringa pubescens* subsp. *patula* 'De Belder,' Quart. J. Int. Lilac Soc. 33(4): 123. 2004. TYPE: South Korea. Mt. Sorak National Park, 1977, National Arboretum 41179 (holotype, US not seen).

Leaves 3.7–10 × 1.9–6 cm, glabrous or pubescent. Inflorescence rachises 4-angled, glabrous or pubescent. Calyces toothed, glabrous or pubescent; corolla tubes funnel-formed, 5–13 mm, throats (1.2–)1.6–2.5(–3) mm wide; anthers (0–)0.1–0.9(–1) mm below corolla throat.

Distribution and habitat. The distribution of *Syringa pubescens* subsp. *patula* is in the Korean Peninsula and northeastern China (Liaoning Province). It grows in deciduous forests or along forest margins.

Discussion. One lectotype was designated here. Nakai (1918) described *Syringa venosa* as new and cited five specimens from Ooryongto. We chose one of Nakai's collections with flowers, T. Nakai 4194, as the lectotype here.

Syringa debelderi J. L. Fiala was described from a cultivated plant that was stated to have small leaf blades (7 × 5 cm) (Fiala, 1988). The name was corrected as *S. debelderorum* J. L. Fiala by Green (1989). The size of leaf blades and other characters of *S. debelderorum* are scarcely different from *S. pubescens* subsp. *patula*.

Representative specimens examined. CHINA. Liaoning: Benxi, C. S. Wang 4390 (PE); Dandong, J. Y. Chen 04107, 04113 (PE); Fengcheng, J. Y. Chen 03248 (PE); Qianshan, Y.

C. Chu 576 (PE); Xiuyan, W. Wang 1556, 1576 (PE). KOREA. s. loc.: V. L. Komarov 1259 (K), J. Sato 4147 (PE), J. Sato 4150 (PE), E. H. Wilson 11705 (PE); Doekyu-san, Hagman 329 (UPS); Kongo-san, E. H. Wilson 10491 (K); Mt. Chiisan, J. Ohwi 6811 (UPS); Shuotsu, J. Ohwi 380 (UPS); Sorak-san, Elsik & Hey 915–77 (K); Chonranam-do, H. T. Im 22226 (TI); Dagelet island, E. H. Wilson 8527 (K); Keiki, Poukhan-san, E. H. Wilson 10741 (K); Ooryonto, T. Nakai 4194 (TI).

Literature Cited

- Chang, M. C. 1992. *Syringa*. Pp. 50–84 in Flora Republicae Popularis Sinicae, Vol. 61. Science Press, Beijing.
- & X. L. Chen. 1990. Studies on Chinese *Syringa* 1. Invest. Stud. Nat. 10: 32–40.
- & P. S. Green. 1996. *Syringa*. Pp. 280–286 in Z. Y. Wu & P. H. Raven (editors), Flora of China, Vol. 15: Myrsinaceae through Loganiaceae. Science Press, Beijing, and Missouri Botanical Garden Press, St. Louis.
- Chen, X. L., X. Y. Zhao & S. Z. Qu. 1989. New materials for genus *Syringa* L. Bull. Bot. Res., Harbin 9(3): 39–41.
- Diels, F. L. 1901. Die Flora von Central-China. Bot. Jahrb. Syst. 19: 531–532.
- Fiala, J. L. 1988. Lilacs: The Genus *Syringa*. Timber Press, Portland.
- Green, P. S. 1989. Lilacs: The Genus *Syringa* [book review]. Kew Mag. 6(2): 90–92.
- & M. C. Chang. 1995. Some taxonomic changes in *Syringa* L. (Oleaceae), including a revision of series *Pubescentes*. Novon 5: 329–333.
- Komarov, V. L. 1901. Species novae Florae Asiae Orientalis (Mansuriae et Koreae borealis). Trudy Imp. S.-Peterburgsk. Bot. Sada 18: 428.
- Lingelsheim, A. 1920. *Syringa*. Pp. 75–95 in A. Engler (editor), Das Pflanzenreich, Vol. 72(IV 243). Wilhelm Engelmann, Leipzig.
- McKelvey, S. D. 1928. The Lilac: A Monograph. The Macmillan Company, New York.
- Nakai, T. 1913. Notulae ad Plantas Japoniae et Coreae. Bot. Mag. (Tokyo) 27: 32–33.
- . 1918. Flora Sylvatica Koreana 10. Bot. Mag. (Tokyo) 32: 124–133.
- Palibin, I. 1900. Conspectus Florae Koreae, Part 2. Trudy Imp. S.-Peterburgsk. Bot. Sada 18: 156.
- Qin, X. K. 1998. Notes on *Syringa meyeri* Schneid. and its confused species. Acta Phytotax. Sin. 36: 359–364.
- Schneider, C. K. 1905. *Syringa*. In F. L. Diels, Beiträge zur Flora des Tsin ling shan und andere zusätze zur Flora von Central-China. Bot. Jahrb. Syst. 36(5, Beibl. 82): 86–89.
- . 1910. Species et formae novae generis *Syringa*. Repert. Spec. Nov. Regni Veg. 9: 79–82.
- . 1911. Illustriertes Handbuch der Laubholzkunde (Band II): 771–785. Gustav Fisher, Jena.
- . 1912. Illustriertes Handbuch der Laubholzkunde (Band II): 1063. Gustav Fisher, Jena.
- . 1913. *Syringa*. 297–301, in Plantae Wilsonianae (Sargent), Vol. 1. Cambridge University Press, Cambridge.
- Skvortzov, B. V. & W. Wang. 1955. Oleaceae. Pp. 471–567 in T. N. Liou (editor), Ill. Fl. Ligneous Pl. N. E. China. Science Press, Beijing.

Tang, T. 1941. A new species of *Syringa* in Shanxi. Bull. Fan Mem. Inst. Biol. Bot. 10: 288.

Turczaninow, N. 1840. Decades Quatuor Plantarum Hucusque Descriptarum Sibiriae. Bull. Soc. Imp. Naturalistes Moscou 13: 73.

APPENDIX 1. The coding of morphological characters used in the analysis of the *Syringa pubescens* complex.

Continuous characters: 1. Length of leaf blades (cm). 2. Width of leaf blades (cm). 3. Ratio of length:width of leaf blades. 4. Number of lateral vein pairs. 5. Length of petioles (cm). 6. Length of inflorescences (cm). 7. Diameter of inflorescences (cm). 8. Number of flowers per inflorescence. 9. Length of calyces (mm). 10. Diameter of calyces (mm). 11. Length of corolla tubes (mm). 12. Diameter of corolla throats (mm). 13. Shape of corolla tube [CTS = (diameter of corolla throat – diameter of corolla base) / length of corolla tube]. 14. Length of corolla lobes (mm). 15. Width of corolla lobes (mm). 16. Anther position at corolla tube from base (mm). 17.

Distance between anthers and corolla throat (mm). 18. Pistil length (mm).

Binary characters: 1. Adaxial leaf surface flat (0); concave (1). 2. Abaxial leaf surface flat (0); convex (1). 3. Calyx lobes truncate (0); toothed (1).

Ordinal characters: 1. Indumentum coverage on adaxial leaf surface 0 (0); 0%–5% (1); 5%–25% (2); 25%–75% (3); 75%–100% (4). 2. Indumentum coverage on abaxial leaf surface 0 (0); 0%–5% (1); 5%–25% (2); 25%–75% (3); 75%–100% (4). 3. Basal veins pinnate (1); connate (2); acrodromous basal (3). 4. Indumentum coverage on petioles 0 (0); 0%–5% (1); 5%–25% (2); 25%–75% (3); 75%–100% (4). 5. Shape of inflorescence rachises terete (1); 4-angular (2); irregular (3). 6. Indumentum coverage on inflorescence rachises 0 (0); 0%–5% (1); 5%–25% (2); 25%–75% (3); 75%–100% (4). 7. Lenticel coverage on inflorescence rachises 0 (0); 0%–5% (1); 5%–25% (2); 25%–75% (3); 75%–100% (4). 8. Indumentum coverage on calyces 0 (0); 0%–5% (1); 5%–25% (2); 25%–75% (3); 75%–100% (4).

A SYNOPSIS OF SOUTH AMERICAN *Echeandia* (ANTHERICACEAE)¹

Robert William Cruden²

ABSTRACT

Eight of the 81 recognized species in *Echeandia* Ortega (Anthericaceae) occur in South America. Four species occur in Venezuela and/or Colombia, one in Ecuador, and three in Peru. The five species in subgenus *Echeandia* are endemic to South America, as is one of the three species in subgenus *Mscavea* Cruden. The other two species in subgenus *Mscavea* occur in both South and Central America. As many as five of the eight species are narrow endemics and four may be quite rare. A comparison of the isotypes of *E. ciliata* (Kunth) Cruden with material from Colombia, Venezuela, and Peru provided evidence that the type gathering was made in Cajamarca, Peru, rather than Caracas, Venezuela, as indicated in Kunth's 1815 protologue. *Echeandia denticulata* Cruden is proposed as a new species to accommodate material from Colombia and Venezuela, which was heretofore included in *E. ciliata*. Two new combinations, *E. herrerae* (Killip) Cruden and *E. weberbaueri* (Poelln.) Cruden, are made, and *Anthericum glareosum* Ravenna (– *E. ciliata*) and *E. aequatoris* Ravenna (– *E. lehmannii* (Baker) Marais & Reilly) are newly synonymized. A neotype for *E. leucantha* Klotzsch and a lectotype for *E. ciliata* are designated. *Anthericum peruvianum* Willd. ex Kunth is an illegitimate name.

Key words: Anthericaceae, Cajamarca, *Echeandia*, endemism, South America.

With 81 recognized species (Cruden, 1999 and references therein; this paper), *Echeandia* Ortega, which occurs from the southwestern United States to southern Peru, is the largest New World genus in the Anthericaceae. Fifty-nine species occur in Mexico, and the distributional ranges of three of those species extend into Central America and two into the southwestern United States. Thirteen species are endemic to Central America, and two species occur in Central America and northwestern South America. Six species are endemic to South America, and one species is known only from the United States.

As presently construed, *Echeandia* includes many of the New World species originally placed in *Anthericum* L. (Cruden & McVaugh, 1989; Cruden, 1994, 1999). Previous workers separated the New World taxa on the basis of connate (*Echeandia*) versus

free anthers (*Anthericum*) (e.g., Baker, 1876; Greenman, 1898; Weatherby, 1910; Hutchinson, 1959; Ravenna, 1988). The incorporation of New World species with free anthers into *Echeandia* was based on unique traits that they shared, e.g., scaled (i.e., squamate) filaments and polycarpic rhizomes. All but two or three of the species in *Echeandia* can be placed easily in one of two subgenera based on morphological and physiological traits (Cruden, 1999). In both subgenera, some species have free anthers while others have connate anthers. For example, in subgenus *Echeandia*, *E. ciliata* (Kunth) Cruden has free anthers and *E. lehmannii* (Baker) Marais & Reilly has connate anthers; in subgenus *Mscavea* Cruden, *E. bolivarensis* Cruden has free anthers and *E. leucantha* Klotzsch has connate anthers. In essence, the use of this key character confused rather than clarified

¹I thank the curators of the following herbaria for allowing me to examine material of *Echeandia*: AAU, B, BH, BM, BR, BRIT, COL, DS, DUKE, F, G, GH, K, LZ, MO, MSB, NY, QCA, P, SMU, U, UC, US, VEN. I greatly appreciate the information, negatives, and photographs of the lectotype of *Echeandia ciliata* provided by Madame Cusset (P). W. Greuter (B) identified and discussed the annotations and provided additional insights regarding the type gathering of *E. ciliata*. Likewise, L. Constance (UC) and R. McVaugh (MICH) provided insight as to the reliability of the labels and the authors of the annotations. I am indebted to C. Oberprieler (B) for examining and providing information on an isotype of *E. ciliata* and T. Raus (B) for checking my identifications of material at B. Many thanks to the following for information about types and other critical specimens: F. Nørgaard and H. Balslev (AAU); E. F. Rodríguez (HUT); L. R. Valencia Reyes (QCA). Also, thanks to R. Vickery (BM), J. Heinrichs (GOET), P. Wilkin (K), and B. Wallnöfer (W) for looking for type material of *E. leucantha*, and to P. Wilkin (K) for providing information on the isotype of *Anthericum glareosum*. The manuscript was much improved by the editorial comments and observations of V. Hollowell (MO), R. Gereau (MO), D. Horton (IA), and an anonymous reviewer. Shelly Plattner (IA) prepared the map and provided much needed technical assistance. My thanks to the staff at F, especially M. Dillon; C. Niezgodá; the staff at MO, especially R. Liesner and J. Solomon; and C. Anderson and A. Reznicek at MICH for their help during my visits to those institutions. Finally, I am grateful for the encouragement and support provided by Debbie and Dick Baker, Lyda and Nathalie Cruden, Diana Gannett, Diana Horton, Virginia and David Lyon, and 'Van' Vandemark during the completion of this study.

²Department of Biology, University of Iowa, Iowa City, Iowa 52242, U.S.A. robert-cruden@uiowa.edu.
doi: 10.3417/2002129

relationships within *Echeandia* and between *Echeandia* and related genera. The latter include the South American genera *Diamena* Ravenna, *Diora* Ravenna, *Hagenbachia* Nees & Mart., and an unpublished genus (Cruden, in prep.), as well as the Old World genera *Anthericum* and *Chlorophytum* Ker Gawl.

Echeandia and its New World relatives are separated by both floral and vegetative traits. Three floral traits (yellow flowers, connate anthers, and/or scaled filaments) distinguish all but four species of *Echeandia* from their South American relatives (Cruden, 1999; see also Ravenna, 1987; Conran, 1998). The four exceptions have white flowers, free anthers, and smooth, terete filaments (Cruden, 1999). All *Echeandia* have a perennial, unsegmented, erect rhizome that gives rise to new roots, a basal rosette of leaves, and a flowering scape each year. Also, their flowers lack nectaries. In contrast, flowers of the related genera in South America are almost always white, very rarely yellowish or possibly bluish white, have free anthers, and have scaleless filaments. The rhizomes of these genera are segmented and the terminal segment produces a set of roots that appears to function through two, three, or more subsequent flowering episodes, basal leaves, and a flowering scape. The flowers of *Diora*, *Diamena*, and the unpublished genus have septal nectaries (Cruden, pers. obs.; Ravenna, 1987, 1988). In addition, *Diora* is distinguished by red pollen and scabrescent capsules, and produces flowering scapes and basal leaves at different times of the year; *Diamena* has long, tubular corollas (Ravenna, 1987); *Hagenbachia* has small flowers, few ovules, small, globose capsules, and roots with no storage areas (Cruden, 1987); and the filaments of the unpublished genus are expanded above the middle (Cruden, pers. obs.).

FLORAL TRAITS AND POLLINATION RELATIONSHIPS

There are substantial differences in floral traits among the South American species that reflect adaptation to different pollinators, different pollinator behaviors, and/or pollination environments. The flowers of *Echeandia lehmannii*, *E. leucantha*, and *E. pittieri* Cruden are nutant, and their anthers taper apically and are united laterally, thus forming a narrow cone that is open at its apex. The cone is vibrated by bees to extract the pollen (Bernhardt & Montalvo, 1979; Conran, 1998; Cruden, pers. obs.). The anthers of *E. bolivarensis* are nonversatile and shed pollen through apical openings that result from the spreading of the anther walls at the top of the line of dehiscence (Cruden, pers. obs.). Each filament is inserted in a deep pit, which holds the anther on the same axis as the filament. Such anthers in Mexican

species, either singly or together, are vibrated by bees to obtain the pollen (Cruden, pers. obs.). The stamens of *E. bolivarensis* are similar to those of *E. campechiana* Cruden, and flowers of the latter are nutant. Likewise, the anthers of *E. weberbaueri* (Poelln.) Cruden are nonversatile, but are held in line with the axes of the filaments by the strongly reflexed walls of the anther sacs and dehiscence is lateral. The flowers of *E. ciliata* and *E. weberbaueri* have straight to somewhat arcuate or declinate styles that extend (2–)3–6 mm beyond the anthers and usually turn upward just below the stigmas. This characterizes flowers that are cernuous or patent. The styles of *E. denticulata* Cruden are deflexed and usually bend forward below and parallel to the anthers, and the stigmas are exerted below and (1–)2–4(–5) mm in front of the anthers. The flowers are probably patent, possibly cernuous, as are the flowers of Mexican species with similar styles (Cruden & McVaugh, 1989:194, 195). In contrast, the flowers of *E. herrerae* (Killip) Cruden appear to be erect or nearly so, and their geniculate styles pass between the filaments. The stigmas are exerted up to 2(–2.5) mm lateral to the stamens or, occasionally, the styles are straight and the stigmas are surrounded by or barely exceed the anthers. A similar relationship between stamens and styles occurs in *Nemastylis* Nutt. (Iridaceae) and *Xyris juncea* R. Br. (Xyridaceae). Erect flowers are frequently associated with plants with short inflorescences that live in open and/or exposed sites. Finally, the failure of most flowers on most plants to produce capsules suggests the flowers of all the species are cross-pollinated and the plants outbred.

ENDEMISM

Five of the eight South American *Echeandia* (Appendix 1) are known from two to four collections and/or have limited distributional ranges and three, *E. denticulata*, *E. herrerae*, and *E. leucantha*, are widespread and relatively common (Fig. 1). *Echeandia ciliata* is endemic to southern Cajamarca, Peru, which is within the Amotape–Huancabamba zone, a region noted for its endemic species (e.g., Berry, 1982; Hensold, 1999; Sagástegui et al., 1999; Weigend, 2002). This species has been collected from ca. 15 km southwest of Cajamarca, i.e., ca. Cumbe Mayo, to 43 km east of the city and from a little southwest of Bambamarca southeast to Cajabamba, a distance of ca. 120 km (Fig. 1). The three collections of *E. lehmannii* with reasonable collection data were made 20–30 km north and northeast of Quito (Ecuador) at sites ca. 30 km apart. These sites are within or close to the Pululahua Crater and the

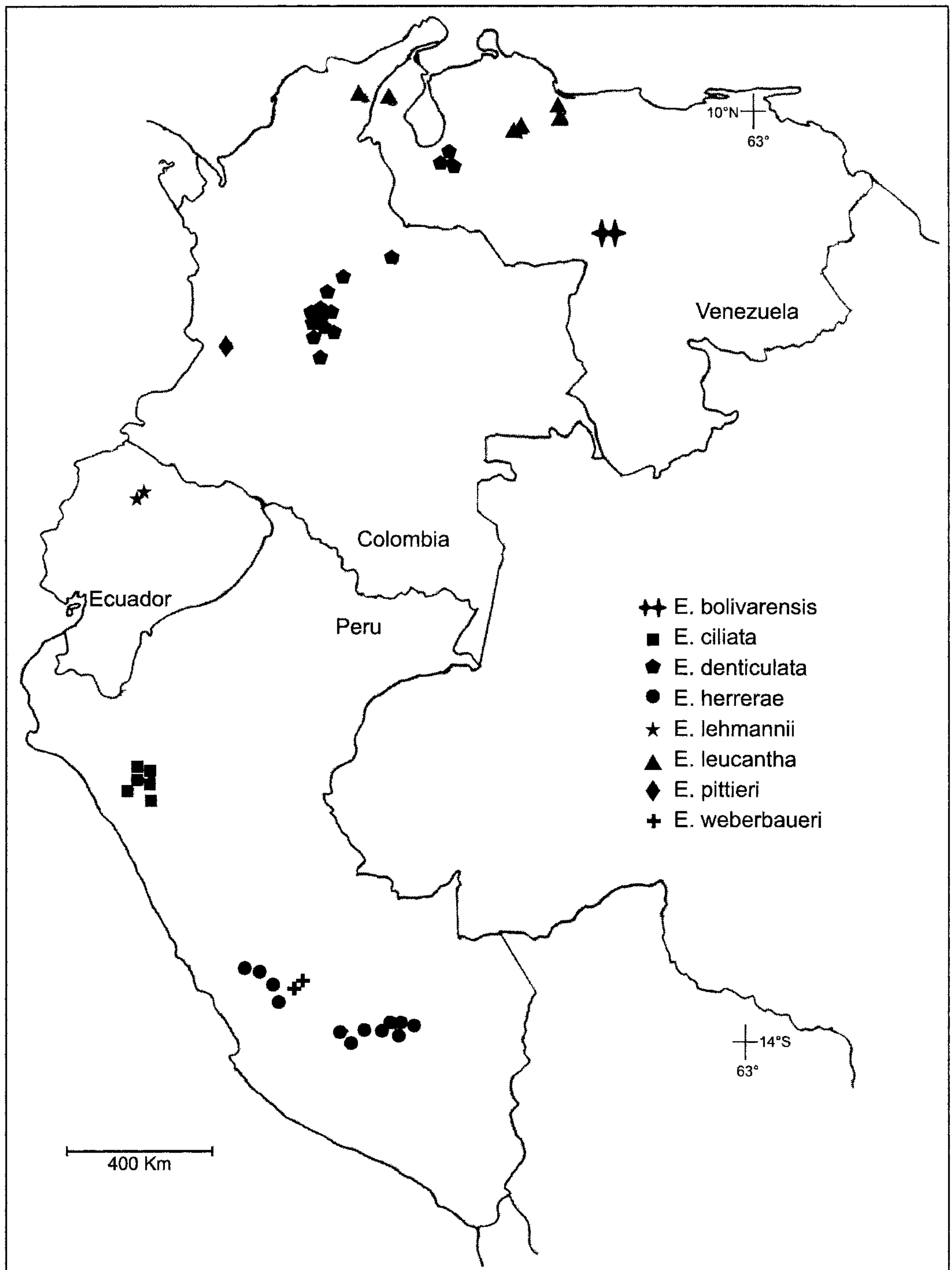

Figure 1. Distributional ranges of the South American species of *Echeandia*.

nearby Volcán Mojanda–Fuya Fuya. The absence of specimens from Volcán Pichincha and similar, nearby sites suggests this species has a restricted range. The two collections of *E. bolivarensis*, which is endemic to

Venezuela, were made within a few kilometers of each other on the Serranía de Los Pijiguaos near Los Pijiguaos in the western part of the state of Bolívar. The proximity of the two localities suggests a limited

distributional range, but the collections probably reflect, at least in part, the development of a bauxite mine on the serranía, which provided easy access to the area. *Echeandia bolivarensis* might well be found elsewhere in the region. Likewise, *E. weberbaueri* may be more widely distributed than the two collections from Peru suggest. These were made 5–10 km apart in or close to the valley of the Río Mantaro ca. 60 km east of Huancayo. *Echeandia pittieri* is known from a single locality in Colombia (Fig. 1) and two in Panama (Cruden, 1986b). This suggests a rare species with a relatively large distributional range.

TAXONOMIC TREATMENT

I. *Echeandia* Ortega, Nov. Pl. Descr. Dec., 135, t. 18.

1800. TYPE: *Echeandia reflexa* (Cav.) Rose, Contr. U.S. Natl. Herb. 10: 93. 1906 [–*Anthericum reflexum* Cav.].

Perennial herbs from short, erect, unsegmented polycarpic rhizomes associated with annual roots with distinct and obvious storage areas, these usually enlarged either close to the rhizome or at some distance; the roots, including the storage areas, usually covered with root hairs. Basal leaves bifacial, very narrowly linear, oblong to elliptic, the bases usually surrounded by a fibrous collar composed of previous years' leaf bases. Scapes bear 0 to 4 (sometimes more) cauline leaves below the lowest branch or flower-bearing node, these reduced in size

acropetally and subtend the branches and flower-bearing nodes. Inflorescences racemose or paniculate with (1 or)2 to 4(or 5) flowers at a node, each flower subtended by a bracteole. Flowers yellow to yellow-orange, or white, very rarely pale yellow or cream, ± erect, cernuous to patent, or nutant; tepals and stamens originate independently on the receptacle; tepals narrowly to broadly elliptic, reflexed to spreading, 3-, rarely 5-veined, these loosely enclose developing capsules and wither prior to dehiscence; filaments free, ± cylindrical to clavate, smooth, wrinkled and scaleless, or bearing transverse scales, insertion in a shallow pit (anthers versatile), deep pit or pocket (anthers nonversatile), or in a deep pocket (anthers connate); anthers yellow, dorsifixed near the base, rarely basifixed, free or connate laterally, if free ± versatile and dehiscing laterally or nonversatile and either dehiscing apically through apical slits or dehiscing laterally, if connate the anthers forming the frustrum of a cone (hereafter cone) whose shape varies from ± cylindrical or barrel-shaped (anthers parallel-sided) with a broadly lobed apex to narrowly conical (anthers tapered from base to apex) with a minutely lobed apex; ovary oblong, superior; ovules 8 or more per carpel. Fruit a loculicidal capsule, broadly to narrowly oblong, rarely ± globose, shallowly 3-lobed; seeds irregularly compressed and folded; seed coat black, colliculose. Chromosome numbers $2n = 16, 32, 48, 64, 80, ca. 84$ (see Cruden, 1994, 1999).

KEY TO THE SOUTH AMERICAN SPECIES OF *ECHEANDIA*

The key was constructed using the specimens listed in Appendix 2, and most of the species were represented by fewer than 10 collections. If those specimens were a biased sample of the variation in a species, the key may not work. Also, because of the considerable overlap of variation in both floral and vegetative traits among species, a few specimens may not key out. However, because most of the species are allopatric, most specimens can be identified using geography (Fig. 1). The key includes the species in both subgenera.

- 1a. Anthers joined laterally, forming a cone; flowers mostly nutant.
 - 2a. Flowers yellow; basal leaves 8–20 cm long; scape 19–32(–40) cm high; 2800–2850 m, Ecuador 4. *E. lehmannii*
 - 2b. Flowers white; most basal leaves 27–83 cm long; scape (40–)65–115 cm high; 190–1500 m, Colombia and Venezuela.
 - 3a. Filaments with transverse scales; storage roots enlarged 3–6 cm from the rhizome; northern Colombia and northwestern Venezuela 7. *E. leucantha*
 - 3b. Filaments smooth; storage roots enlarged 1–2 cm from the rhizome; western Colombia 8. *E. pittieri*
- 1b. Anthers free; flowers erect, cernuous, patent, or possibly nutant.
 - 4a. Scape 98–118 cm high; cauline leaves 4 or 5, the lowest 10–19 cm long; storage areas of roots enlarged (1–)3–6 cm from the rhizome, most 3–5 cm long; below 700 m, Venezuela 6. *E. bolivarensis*
 - 4b. Scape to 70 cm high, rarely higher; cauline leaves 0 to 2, rarely 3, lowest 0.6–3.5(–5.1) cm long; storage areas of roots enlarged 1–2 cm from the rhizome, 1–3 cm long, rarely longer; above 1000 m, Venezuela, Colombia, Peru.
 - 5a. Flowers erect; styles 2–6(–6.5) mm long, geniculate, occasionally straight and the stigmas equal to or barely exceeding the anthers; pedicels of flowers 2.5–6(–7) mm long; 2800–3824 m, Peru, Junín south to Apurímac and Cuzco 3. *E. herrerae*
 - 5b. Flowers patent to cernuous; styles (5.5–)6–11 mm long, straight to somewhat deflexed, exerted 2–6 mm beyond the anthers; pedicels of flowers (4–)5–15 mm long.

- 6a. Filaments bearing transverse scales and margins of the basal leaves entire to denticulate, occasionally short-ciliate or rarely ciliate; (1300–)2300–3500 m, Colombia and Venezuela 2. *E. denticulata*
- 6b. Filaments smooth, wrinkled and scaleless, or occasionally bearing small, narrow, transverse scales; margins of the basal leaves short-ciliate to long-ciliate, rarely denticulate; Peru.
- 7a. Tepals usually twice or more than twice the length of the stamens; anthers 1.5–2.5 mm long, becoming twisted or strongly curved during or after anthesis; capsules 10–12 mm long; most basal leaves 2–7 mm wide, usually falcate; 2500–3400 m, Cajamarca 1. *E. ciliata*
- 7b. Tepals usually less than twice the length of the stamens; anthers (2–)2.5–4 mm long, most remaining straight after anthesis; capsules 12–13.5 mm long; most basal leaves 6–12 mm wide, frequently flat; 2300–2700 m, Huancavelica 5. *E. weberbaueri*

THE SUBGENERA

The two subgenera of *Echeandia*, both of which are represented in South America, are distinguished by the shape of their inner tepals, time of flower opening, and whether the flowers are primarily yellow or white and the anthers free or connate. The South American species are morphologically similar to their Mexican and Central American relatives, upon which this discussion is predicated (see Cruden, 1999). Species in subgenus *Echeandia* have elliptical to broadly elliptical inner tepals that are usually equal to or greater than 4.5 mm wide. Forty of the 55 species have yellow to orange flowers, 10 have white flowers, and five species have populations that are either yellow-flowered or white-flowered. Approximately two thirds of the species in subgenus *Echeandia* have free anthers, and the anthers of the remainder are connate laterally. In most of the species with free anthers, the anthers dehisce laterally. In contrast, 24 of 26 species in subgenus *Mscavea* have narrowly elliptical tepals (maximum width, 4.5 mm), and 21 of the 26 species have white flowers, two have cream-colored flowers, two have orange flowers, and one has populations with either white or orange flowers. Twenty-one of the 26 species have connate anthers and the other five have free anthers that dehisce apically. Further, based on the observation of ca. 50 Mexican and Guatemalan species in the field and/or greenhouse, the flowers of species in subgenus *Echeandia* open early in the morning and close by mid- or late afternoon whereas those in subgenus *Mscavea* open from late in the morning to early afternoon and close in late afternoon or early evening. Also, species in subgenus *Echeandia* tend to occur at higher elevations in relatively mesic habitats with warm- to cold-temperate climates compared to species in subgenus *Mscavea*. The latter occur at lower elevations in drier habitats with subtropical to warm-temperate climates. With the exception of a few decaploid ($2n = 80$ chromosomes) species in subgenus *Echeandia*, equivalent chromosome numbers occur in the two subgenera (Cruden, 1994, 1999). In both subgenera, diploid species predominate in Mexico north of the Isthmus of Tehuantepec and polyploid species are more common to the south of the isthmus, i.e., in Central America

(Cruden, 1994). No documented chromosome numbers are known for the South American species. Finally, illustrations and/or photographs of species in the two subgenera are found in Bernhardt and Montalvo (1979: 68), Cruden and McVaugh (1989: 187, 194, 195), and Conran (1999: 116).

The five South American species in subgenus *Echeandia* are similar to their Mexican and Central American relatives, but they exhibit a relatively small subset of the variation exhibited by their northern relatives (Cruden & McVaugh, 1989; Cruden, 1994). Those five species, all of which are endemic to South America, have yellow flowers with elliptical to broadly elliptical inner tepals, four have free anthers, and all occur above 2000 m (but see *E. denticulata*). The storage areas of the roots develop 0.5–2 cm from the rhizome, the scapes are mostly 15–50 cm high, and the main axes of the inflorescences support six to 15 flower-bearing nodes. If the filaments bear transverse scales, they are quite narrow to relatively narrow.

I suggest the species in subgenus *Echeandia* might have had a common ancestor because they are similar morphologically and the traits that distinguish them are primarily qualitative. The latter include the relative numbers of plants with dentate versus ciliate leaf margins, scaled versus scaleless filaments, the length of the stamens vis-à-vis the length of the tepals, and/or glabrous versus scabrescent scapes. The unique traits that distinguish *E. herrerae*, e.g., its shorter stature, erect flowers, and geniculate styles, may reflect its growing in open, exposed habitats. The major difference between *E. lehmannii* and the other South American species are its connate anthers. In essence, it appears that the extant species have somewhat different combinations of traits that might have characterized a common ancestor. Finally, the South American species are similar to *E. skinneri*, the only Central American species with free anthers that is found south of Guatemala. There is no Central American species that is an obvious progenitor of *E. lehmannii*.

Only one of the three species in subgenus *Mscavea*, *Echeandia bolivarensis*, is endemic to South America, and it is just one of three species in the subgenus with yellow flowers. One of these, *E. campechiana*, which is endemic to the Yucatán Peninsula in Mexico, is also a

robust species with tall scapes (0.9–1.5 m high), numerous branches, and smaller flowers (tepals 8–11 mm long) with anthers that dehisce apically (Cruden, 1994). The other two species in subgenus *Mscavea* have white flowers with narrowly elliptical inner tepals and connate anthers. These species, *E. leucantha* and *E. pittieri*, occur in both northwestern South American and Central America below 1500 m.

Ia. *Echeandia* subgen. *Echeandia*

Flowers yellow, occasionally white; inner tepals elliptic to broadly elliptic; flowers opening in early morning and closing in early to mid-afternoon (Cruden, 1999).

1. ***Echeandia ciliata*** (Kunth) Cruden, *Phytologia* 59: 380. 1986. Basionym: *Phalangium ciliatum* Kunth, *Nov. Gen. Sp.* [HBK] (quarto ed.) 1: 276, t. 676. 1815 [1816]. *Anthericum ciliatum* (Kunth) Spreng., *Syst. Veg.* 2: 84. 1825, nom. illeg., non *Anthericum ciliatum* L. f., 1781, nec *Anthericum ciliatum* (Kunth) Schult. & Schult. f., *Syst. Veg.* 7(1): 466. 1829. *Anthericum humboldtii* Hemsl., *Biol. Cent.-Amer., Bot.* 3: 374. 1884, replacement name for *A. ciliatum* (Kunth) Schult. & Schult. f. *Anthericum sprengelii* Rusby, *Mem. Torrey Bot. Club* 6: 127. 1896, nom. illeg., replacement name for *A. ciliatum* (Kunth) Spreng., pro syn. *A. humboldtii*. TYPE: [Peru.] "Crescit prope Caracas, alt. 470 hex., Floret Januari," *F. W. H. A. Humboldt & A. J. A. Bonpland s.n.* (lectotype, designated here, P-Bonpl. not seen, photo!; isotypes, P!, B-W 6657/1 not seen, photo!).

Anthericum glareosum Ravenna, *Onira* 1: 29. 1988. Syn. nov. TYPE: Peru. Cajamarca: Cajamarca, El Cumbé, 2800 m, 17 Apr. 1958, *A. López 1307* (holotype, Hb. Ravennae not seen; isotypes, HUT 2622 not seen, K not seen, US!).

Anthericum peruvianum Willd. ex Kunth, *Index Kew.* 1: 146. 1895, nom. illeg. Based on *Anthericum peruvianum* Kunth, *Enum. Pl.* 4: 596, 1843, nom. nud. (see nomenclature).

Storage areas of roots enlarged 0.5–1 cm from the rhizome, 1–2(–2.5) cm long. Basal leaves 5 to 10(to 14), 6–15(–19) cm × (1–)2–7(–9) mm, falcate, rarely flat, ciliate to long-ciliate, occasionally short-ciliate to ciliate, rarely densely so; cauline leaves 0 or 1(or 2), if present, the lowest 8–21 mm. Scape 1, (8–)21–50 cm high, rarely a few centimeters higher, height (1.2–) 2.5–4 times the length of the longest basal leaf, glabrous or nearly so to minutely scabrescent toward the base, branches 0 or 1(or 2); main axis of inflorescence with 6 to 16 flower-bearing nodes, lowest 1- or 2-flowered, upper 1-flowered; flowers yellow, most cernuous to patent; pedicels (4–)5–

9 mm; tepals (12–)13–16.5(–18.5) mm, usually twice or more than twice the length of the stamens, probably spreading to somewhat reflexed, inner tepals 6 mm or more wide; filaments 5–7 mm, ± straight, smooth or wrinkled and scaleless, occasionally bearing a few tiny, quite narrow to numerous small, narrowly transverse scales, inserted in a shallow pit; anthers free, versatile, 1.5–2.5(–3.5) mm, or longer if not curled and/or twisted, dehiscence lateral; ovary 2–3(–3.5) mm; styles 6–10 mm, straight to gently arcuate, turned upward below the stigma; the stigma exerted (2–)3–6 mm beyond the anthers. Capsules oblong, 10–12 × 4.5–5 mm.

Distribution and habitat. This slender-stemmed species is endemic to southern Cajamarca, Peru, between 2500 and 3400 m elevation, from south of Bambamarca southeast to near Cajabamba and from 15 km southwest of Cajamarca (Cumbe Mayo) to ca. 43 km east of Cajamarca (Fig. 1). It is usually a plant of dry and/or rocky places, including over-grazed hillsides where it grows among shrubs and other herbs. It was also found in disturbed roadsides and edges of cultivated fields.

Phenology. In flower January to May.

Discussion. A combination of floral and vegetative traits distinguishes *Echeandia ciliata* and separates it from other South American species in subgenus *Echeandia*. It is distinguished by the narrow, falcate, basal leaves whose margins are ciliate, slender scapes ([8–]21–50 cm high [rarely a few centimeters higher]) that are frequently three to four times the length of the longest basal leaf, relatively large flowers (tepals [12–] 13–16.5[–18.5] mm long), and tepals that are usually twice or more than twice as long as the stamens.

Echeandia ciliata is most likely to be confused with *E. denticulata*. The filaments of most specimens of *E. ciliata* were scaleless and the leaf margins ciliate, whereas the filaments of all the specimens of *E. denticulata* were scaled and most (39 of 49 specimens) had entire to denticulate leaf margins. However, occasional specimens of both *E. ciliata* (e.g., *Dillon et al.* 2862 and *Sagástegui 15148*) and *E. denticulata* may have scaled filaments and ciliate leaf margins. In addition, the capsules of *E. ciliata* were smaller than those of *E. denticulata* (10–12 mm vs. [9–]11–17 mm long).

Most specimens of *Echeandia ciliata* were easily distinguished from those of *E. herrerae* and *E. weberbaueri*. In general, the tepals of *E. ciliata* were twice or more than twice the length of the stamens, whereas those of *E. herrerae* and *E. weberbaueri* were usually less than twice the length of their stamens. Further, the flowers of *E. herrerae* were generally

smaller (tepals 9–13[–15] mm vs. [12–]13–16.5 [–18.5] mm long) with shorter pedicels (2.5–6[–7] mm vs. [4–]5–9 mm long), shorter geniculate styles (2–6[–6.5] mm vs. 6–10 mm long), and generally shorter (4–26[–ca. 45] cm vs. [8–]21–50 cm high, rarely a few centimeters higher) and noticeably scabrescent to scabrous scapes that were usually less than twice the length of the longest basal leaf. The scapes of *E. ciliata* were usually three to four times the length of the longest basal leaf and smooth to minutely scabrescent toward the base. Compared to plants of *E. weberbaueri*, those of *E. ciliata* had somewhat shorter scapes ([8–]21–50 cm vs. 34–59 [–68] cm high), falcate basal leaves that were shorter (6–15[–19] cm vs. [6.5–]10–25[–33] cm) and narrower ([1–]2–7[–9] mm vs. [3–]6–12 mm), and, if present, shorter cauline leaves (8–21 mm vs. 16–35[–49] mm long). Also, the anthers of most specimens of *E. weberbaueri* were longer ([2–]2.5–4 mm vs. 1.5–2.5 mm), usually nonversatile, and remained straight to somewhat curved during and after dehiscence, whereas those of *E. ciliata* were versatile and twisted during or after dehiscence. Finally, *E. ciliata* is geographically disjunct from both *E. herrerae* and *E. weberbaueri* (Fig. 1). The former occurs on the Pacific slopes of the Andes in southern Cajamarca, and the latter two occur 500 km or more to the south on the Atlantic slopes of the Andes from Junín south to Apurímac and Cuzco.

Nomenclature. Here I compare the type gathering of *Phalangium ciliatum* (– *Echeandia ciliata*) (Humboldt & Bonpland s.n.) with specimens from Venezuela, Colombia, and Peru and show that the epithet *ciliata* should be applied to plants from Peru. The sheet bearing the lectotype of *Phalangium ciliatum* bears two labels, both in the lower left-hand corner. One is a printed label: “HERB. MUS. PARIS, Herbarium Humboldt & Bonpland. AMÉRIQUE ÉQUATORIALE,” and the second bears an annotation by Kunth (L. Constance, pers. comm.; W. Greuter, pers. comm.): “I,” “*Phalangium ciliatum*.” The sheet bears a complete specimen on the right, which is the lectotype, and parts of a second on the left. I designated the complete specimen as the lectotype because it is nearly identical to the illustration (tab. 676) that accompanied Kunth’s protologue and undoubtedly served as the model for the illustration.

The isotypes bear Bonpland’s collection labels, which are virtually identical. The sheet at P bears two specimens, the scape of a third, and three labels. The label in the lower left-hand corner was annotated by Bonpland (M. Cusset, pers. comm.; also see Rankin Rodríguez & Greuter, 2001: fig. 5): “VII. Ornithogalum?” in the upper left corner and “Perou” in the lower

right corner. The label in the lower right-hand corner of the sheet has printed above: “HERB. MUS. PARIS” followed by an annotation (possibly by an older Kunth [W. Greuter, pers. comm.]): “*Phalangium ciliatum* HBK. N. Gen. I. 276.”; in a second hand: “*Anthericum* R. Sch.”; below that, possibly by Kunth (W. Greuter, pers. comm.): “Caracas,” and printed across the bottom “Herbier de l’Amérique équatoriale, donné par M. A. Bonpland.” The second hand might well be that of Richard Schomburgk. A printed label “isotype” is affixed over the upper right-hand corner of the second label.

The isotype described immediately above includes two flowers. The single filament that can be observed in one flower is smooth. The flower in the pocket has five filaments that are relatively smooth, and the sixth bears a few tiny, narrow scales. The scales were barely discernible with a 10× hand lens in good, artificial light, and thus might have appeared as glabrous to Kunth. The tepals are more than twice the length of the stamens. Finally, the leaf margins of one plant are mostly short-ciliate to ciliate, and those of the second are irregularly denticulate to short-ciliate with occasional longer enations. The scapes are minutely and sparsely scabrescent toward the base. With the exception of the leaf margins of one specimen, these traits are consistent with the description of *Phalangium ciliatum* (Kunth in Humboldt et al., 1815).

The sheet at B-W bears two plants, one intact with roots and the other a scape and detached leaves. Both the sheet and a label were annotated by Schlechtendal and it bears Bonpland’s collection label. The sheet is annotated “Anth. peruvianum l.” in the upper right-hand corner and “Humboldt. W.” in the lower right-hand corner (both by Schlechtendal; cf. Rankin Rodríguez & Greuter, 2001: fig. 3). The latter indicates that Humboldt donated the specimen and that it was deposited in the Willdenow herbarium (W. Greuter, pers. comm.). Bonpland’s collection label (lower left) is virtually identical to the label on the isotype at P: upper left; “VII. Ornithogalum?”; lower left; “(Humboldt)” and lower right; “Perou.” The “(Humboldt)” was added by Schlechtendal (W. Greuter, pers. comm.; cf. Rankin Rodríguez & Greuter, 2001), another indication that Humboldt was the source of the specimen (L. Constance, pers. comm.; W. Greuter, pers. comm.; also see McVaugh, 1955). The general aspect of the specimen (see photographs: types of the Berlin Herbarium at F, GH) is remarkably similar to the isotype (P) as are the flowers. Two of the filaments have noticeable transverse scales, which the others lack. The leaf margins are ciliate with most enations 0.10–0.25 mm long, and the scapes are minutely scabrescent toward the base (C. Oberprieler, pers. comm.).

The plants on the sheet at B-W and the two at Paris surely constitute a single gathering. First, the specimens are similar morphologically. Second, the isotypes are linked by Bonpland's collection labels and Schlechtendal's annotations indicating that the sheet at Berlin came from Humboldt. Third, the annotation "Caracas" on the isotype (P) links it with the protologue, hence the lectotype. There being a single gathering would explain why Schultes and Schultes f. (1829: 466), based on information from the younger Schlechtendal, included *Anthericum peruvianum* as a synonym of *A. ciliatum* and Kunth (1843: 596), who had firsthand knowledge of the specimens, included it as a synonym of *Phalangium ciliatum*.

The combination *Anthericum peruvianum* Willd. ex Kunth has no standing as it was not legitimately described. Jackson (1895: 147) attributed the name to Kunth, whose name was illegitimate. In his treatment of *Phalangium ciliatum*, Kunth identified the isotype at B-W as "*Anthericum peruvianum* Willd. herb. no. 6657" and included this brief passage as a synonym of *P. ciliatum*. In essence, Kunth identified the herbarium sheet as being the same as the plants included in *P. ciliatum*. The combination is not legitimately described because the name was included as a synonym of *A. ciliatum* (McNeill et al., 2006: Art. 34.1.c) and no description was provided. Earlier, Schultes and Schultes f. (1829: 466) in their treatment of *A. ciliatum*, immediately following their reference to Kunth's *P. ciliatum*, provided a diagnosis of *A. peruvianum* and cited Willdenow's notes: "*Anthericum peruvianum*, fol. lin....scapo simplicis. Reliqu. Willd. Ms. (fide de Schlechtend. fil.)." Although a type specimen was not designated, it is clear that the name was associated with the isotype at B-W. Even so, this combination was not legitimately described as it was included as a synonym of *A. ciliatum*.

The holotype of *Anthericum glareosum* was unavailable for examination, and, as of April 2009, K had not received the isotype (P. Wilkin, pers. comm.). The presence of the isotype at HUT was confirmed by E. F. Rodríguez.

Provenance of Echeandia ciliata. For nearly 200 years, systematists used Kunth's *Phalangium ciliatum* to describe plants collected in Colombia or Venezuela (included here in *Echeandia denticulata*) as well as elsewhere in South America (e.g., Hauman, 1917; Guaglianone, 1996). The former is surely due to Kunth's observation in the protologue "Crescit prope Caracas....," which was repeated by subsequent workers (e.g., Baker, 1876; Cruden, 1986a). However, based on the material I examined, this and other information in Kunth's protologue are not supported by the available data. First, *Echeandia* is unknown

from the region around Caracas, and the nearest populations of *E. denticulata* are in the Cordillera de Mérida, 300–400 km to the southwest of Caracas, an area that Humboldt and Bonpland did not visit (Sandwith, 1925; Stearn, 1968; Núñez & Petersen, 1970). Second, no population of either *E. ciliata* or *E. denticulata* has been found as low as 470 hexameters (ca. 916 m). Third, the isotypes bear Bonpland's collection labels (W. Greuter, pers. comm.), indicating they were collected in Peru. Fourth, Kunth (in Humboldt et al., 1815) described the flowers as white, but yellow is the only flower color reported for subsequent collections of South American species in subgenus *Echeandia*. These contradictory observations may reflect the absence of field notes concerning these specimens. Neither the lectotype nor isotypes bear a number that would associate them with an entry in Humboldt and Bonpland's field notes (W. Greuter, pers. comm.), thus the source of the information on location, its elevation, time of collection, and flower color is unknown. The absence of field notes undoubtedly accounts for McVaugh's observation that Kunth included inaccurate collection data in his protologues with some frequency (R. McVaugh, pers. comm.). In contrast, Bonpland's collection labels were probably reliable (W. Greuter, pers. comm.). Below, I briefly discuss flower color, examine Humboldt and Bonpland's itinerary, and compare a number of traits to establish a possible origin for the Humboldt and Bonpland gathering.

Given the absence of field notes and no indication of flower color on Bonpland's field labels, one can only speculate as to why Kunth (in Humboldt et al., 1815) described the flowers as white, whereas all the other specimens of *Echeandia ciliata* I examined were yellow-flowered. Further, the only flower color reported for the other South American species in subgenus *Echeandia* was yellow (33 collections representing four species). Today, the original color of the flowers on the isotype at P is problematic; thus, it is possible the flowers examined by Kunth had faded from yellow to appearing off-white. It is also possible that Humboldt and Bonpland encountered a rare, white-flowered population. The former seems the more likely explanation.

An examination of Humboldt and Bonpland's itinerary (Humboldt et al., 1825; Sandwith, 1926; Sprague, 1926; Stearn, 1968; Núñez & Petersen, 1970) shows that they could have encountered only *Echeandia denticulata* and/or *E. ciliata*. They could not have encountered *E. herrerae* or *E. weberbaueri* because they did not visit the east side of the Andes where those species occur. Humboldt and Bonpland were in or near Bogotá, Colombia, between June and September of 1801 (Sprague, 1926), when *E. den-*

ticulata is typically in flower (see below), and visited localities where *E. denticulata* was subsequently collected, i.e., Suba and Cota. They were in the vicinity of Cajamarca in northwestern Peru in mid-September 1802 (Sandwith, 1926; Stearn, 1968; Núñez & Petersen, 1970) and visited or were close to a number of sites where *E. ciliata* was subsequently collected, e.g., between Hualgayoc and Cajamarca (north of Cajamarca), Baños del Inca (east of Cajamarca) and Cumbe Mayo, and other sites between Cajamarca and Magdalena to the southwest of Cajamarca (cf. Humboldt and Bonpland's itinerary [Humboldt et al., 1825; Sandwith, 1926; Stearn, 1968] with specimens listed below).

A comparison of two traits establishes Cajamarca as the most likely source of the type gathering of *Phalangium ciliatum* rather than Colombia. First, Kunth (in Humboldt et al., 1815) described the filaments of *P. ciliatum* as glabrous, as were most of the filaments of the two isotypes and most of the specimens I examined from Cajamarca. Of the latter, the filaments of flowers from six populations (12 plants) were either smooth (nine specimens) or wrinkled and scaleless (three specimens). The filaments of flowers from two populations (six plants) bore tiny to small, quite narrow to narrow, transverse scales. These populations were to the east (*Dillon et al.* 2863) and southeast of Cajamarca (*Sagástegui* 15148), areas not visited by Humboldt and Bonpland. In contrast, the upper half of the filaments of all the specimens with visible filaments that I examined from Colombia and Venezuela (22 plants from nine populations) bore numerous, transverse scales, which, in general, were easily observed with a 10× hand lens in natural light.

Second, the leaf margins of most of the plants from Peru were ciliate and most of those from Colombia and Venezuela were denticulate. Kunth described the leaf margins of *Phalangium ciliatum* as ciliate (Kunth in Humboldt et al., 1815). The leaf margins of three of the four plants that constitute the isotypes were short-ciliate to ciliate (most enations 0.1–0.25 mm long). The margins of the fourth plant (at P) were a mixture of tiny teeth and tiny, short cilia, with occasional longer enations. The leaf margins of the specimens that I examined from Cajamarca were either short-ciliate to ciliate (23 of 26 specimens) or ciliate to long-ciliate (three of 26 specimens). In contrast, the leaf margins of most of the plants I examined from Colombia and Venezuela were entire to denticulate (39 of 49 plants) (enations to 0.14 mm long) and occasionally denticulate/short-ciliate (seven plants) or short-ciliate (three plants).

Based on these comparisons, it seems reasonable to conclude that the type gathering was made in

Cajamarca rather than Colombia. The specimens I examined from Cajamarca had ciliate leaf margins and the filaments were either scaleless or bore narrow to quite narrow, transverse scales, whereas the flowers of the plants in the Humboldt and Bonpland gathering had a mix of filaments that were either smooth or bore quite narrow, transverse scales as well as having ciliate leaf margins. In contrast, the plants from Colombia had noticeably scaled filaments and most had entire to denticulate leaf margins.

Also, plants from Colombia and Venezuela were more likely to have smooth scapes, whereas those from Peru were more likely to be weakly scabrescent toward the base to scabrous in the lower half, which is consistent with the type gathering being made in Peru. Kunth (in Humboldt et al., 1815) described the scapes of *Phalangium ciliatum* as smooth apically and minutely scabrescent toward the base. This was true of the isotypes and 14 of 24 specimens from Cajamarca (the others being smooth or nearly so). In contrast, 56 of the 63 specimens from Colombia and Venezuela had smooth scapes, and the scapes of the other seven were weakly scabrescent toward the base.

The only information that is inconsistent with Cajamarca being the location of the Humboldt and Bonpland gathering is the flowering period of *Echeandia ciliata*. Based on the nine gatherings I examined, *E. ciliata* flowers from late December to late May, whereas Humboldt and Bonpland were in Cajamarca in September. Thus, it might seem unlikely that Humboldt and Bonpland found *E. ciliata* in flower. However, flowering at atypical times occurs in other species, e.g., *E. leucantha* (see below; see also Hofreiter & Rodríguez, 2005). Such occurrences may be relatively common in tropical regions with seasonal dry forests where flowering may be triggered by rainfall rather than photoperiod (e.g., Augspurger, 1981; see also Janzen, 1966; Rathcke & Lacey, 1985).

The available evidence supports two conclusions: (1) the Humboldt and Bonpland gathering included the lectotype and the isotypes, and (2) the gathering was made in Cajamarca. Several lines of evidence support the first conclusion. The specimens are morphologically similar, and Bonpland's collection labels on the isotypes are virtually identical. The annotations on the isotype at P connect it with the lectotype, and the annotations on the isotype at B-W link it to that at P. In addition, the inclusion of *Anthericum peruvianum* as a synonym of *A. ciliatum* by Schultes and Schultes f. (1829) and as a synonym of *Phalangium ciliatum* by Kunth (1843) connects it with the lectotype.

Likewise, several lines of evidence are consistent with the conclusion that the Humboldt and Bonpland gathering was made in Cajamarca. First, the Hum-

boldt and Bonpland specimens are similar morphologically to specimens collected in Cajamarca and distinct from material collected in Colombia and elsewhere in Peru. Second, Bonpland's collection labels on the putative isotypes indicate the specimens were collected in Peru, and Bonpland's labels are considered to be relatively accurate (see above). Third, Humboldt and Bonpland were in Cajamarca but did not visit the east side of the Andes where *Echeandia herrerae* and *E. weberbaueri* occur.

The use of "*ciliata*" to describe material from Colombia and Venezuela for nearly 200 years reflects three factors: (1) the repeated citation of Caracas as the type locality (e.g., Baker, 1876; Cruden, 1986a); (2) with the exception of a few traits, *Echeandia denticulata* and *E. ciliata* are remarkably similar, and without a clear alternative there was no reason to question the usage; (3) based on the material I examined, no collections of *E. ciliata* were made between 1802 and 1958. In essence, the alternative was unknown.

Additional specimens examined. PERU. **Cajamarca:** Cajabamba, near Cajabamba, *Sagástequi 15148* (F, MICH); Hualgayoc, Las Ventanillas–Frutillopampa, 10 km S of Bambamarca, *Sánchez Vega et al. 5687* (F); 5 km S of Cajamarca, rd. to the coast, *Sánchez Vega 3266* (F); rd. to Cumbé Mayo, W of Cajamarca, *Sánchez Vega et al. 1846* (F); Baños del Inca, above Pullucana, carr. Cajamarca–Celendín, *Sánchez Vega 4278* (F); 2 km from Baños del Inca on rd. from Cajamarca to Celendín, *Weigend et al. 97/427* (F); rd. to Celendín, Km 20, *Gutte & Müller 9375* (LZ); 43 km E of Cajamarca, 27 km N of San Marcos, *Dillon et al. 2862* (F, MO).

2. *Echeandia denticulata* Cruden, sp. nov. TYPE:

Colombia. Cundinamarca: extreme SW corner of Sabana de Bogotá, betw. Sibaté & San Miguel, 2750 m, 15 Aug. 1939, *J. Cuatrecasas 6639* (holotype, COL!; isotypes, F!, US!). Figure 1.

Haec species *Echeandiae ciliatae* (Kunth) Cruden et *E. weberbaueri* (Poelln.) Cruden similis, sed ab eis filamentis manifeste squamosis et foliis basalibus integris usque denticulatis distincta; a *E. herrerae* (Killip) Cruden stylis longioribus et floribus cernuis usque patentibus differt; in Colombia et Venezuela indigena.

Storage areas of roots enlarged 0.5–1.5 cm from the rhizome, 1–4(–6) cm long. Basal leaves (3 to)4 to 14, (8–)10–42(–57) cm \times (3–)4–10(–12) mm, straight and flat to falcate, entire to denticulate, rarely ciliate or long-ciliate, enations to 0.15(–0.26) mm; cauline leaves 0 to 2(or 3), if present, the lowest 1.3–3.4(–5.1) cm. Scape 1(or 3), (10–)15–55(–85) cm high, glabrous throughout or occasionally glabrous apically and minutely scabrescent toward the base, 0 to 2(to 4) branches; main axis of inflorescence with (3 or)4 to 11(to 14) flower-bearing nodes, the lowest 2-flowered, occasionally 1-flowered in small plants or 3-flowered

in large plants. Flowers yellow, most cernuous to patent; pedicels (4–)5.5–10(–11) mm; tepals 12.5–18(–20) mm, probably spreading to somewhat reflexed, inner 5–8 mm wide; filaments 5–7 mm, \pm straight, bearing numerous, narrow, transverse scales; anthers free, (1.5–)2–3 mm, versatile, straight to weakly curved, dehiscence lateral; ovary (2.5–)3–4(–5) mm; styles (5.5–)6–8.5(–9.5) mm, bent downward and then forward or weakly to strongly deflexed, rarely straight, arcuate, occasionally turned upward below the stigma, the stigmas exerted (1–)2–4(–5) mm beyond and below the level of the anthers. Capsules oblong, (9–)11–17 \times 4.5–7 mm.

Distribution and habitat. This species is found primarily between 2300 and 3500 m, rarely to 3900 m, in the Cordillera Oriental in Colombia and Cordillera de Mérida in adjacent Venezuela (Fig. 1). Two collections made near Quetame, Colombia (*Pennell 1856* [NY, US] and *Lehmann 8842* [F, K]), are elevationally and somewhat geographically disjunct from the nearest populations of *Echeandia denticulata*. These were made between 1300 and 1800 m, a little southeast of the southeastern-most collection of *E. denticulata*, which was made south of Usme between 3000 and 3100 m. *Echeandia denticulata* is a plant of savannas and páramo, and occurs occasionally in pastures and cultivated fields.

Phenology. In flower (April to) mid-June to September (to mid-October).

Discussion. In addition to being geographically disjunct from its Peruvian relatives (Fig. 1), most specimens of *Echeandia denticulata* were easily identified by their scaled filaments and/or entire to denticulate leaf margins. The filaments of the specimens of *E. denticulata* with visible filaments (22 plants from nine populations) were scaled, and the leaf margins of most of the specimens were either entire (seven of 49 specimens), entire/denticulate (six specimens), or denticulate (26 specimens) and relatively few were either denticulate/short-ciliate (seven specimens) or short-ciliate (three specimens). In contrast, the filaments of most of the Peruvian specimens were either smooth (37 of 66 specimens) or wrinkled and scaleless (16 specimens), and relatively few specimens (13 of the 66) bore small, narrow, transverse scales. The leaf margins of most of the Peruvian plants were short-ciliate to long-ciliate (79 of 99 specimens) or denticulate/short-ciliate (18 specimens), and the leaf margins of just two specimens were denticulate. Also, compared to those of *E. denticulata*, the capsules of *E. ciliata* were smaller (10–12 mm vs. [9–]11–17 mm long) and the flowers of *E. herrerae* were erect rather than cernuous

or patent, with tepals shorter (9–13[–15] mm vs. 12.5–18[–20] mm) and styles geniculate and shorter (2–6 [–6.5] mm vs. [5.5–]6–8.5[–9.5] mm). Further, the anthers of *E. denticulata* were versatile and somewhat shorter than those of *E. weberbaueri* ([1.5–]2–3 mm vs. [2–]2.5–4 mm long) and became twisted during or after dehiscence, whereas those of *E. weberbaueri* were nonversatile and usually remained straight after dehiscence.

Other traits differed qualitatively between *Echeandia denticulata* and its Peruvian relatives. The scapes of 56 of 63 specimens of *E. denticulata* were glabrous and seven were minutely scabrescent toward the base, whereas the scapes of most of the Peruvian plants were minutely scabrescent to scabrous (86 of 115 plants). Among specimens of *E. denticulata*, there was no relationship between tepal length and stamen length, but there were strong biases in the Peruvian species. The tepals of *E. denticulata* were more than twice the length of the stamens in nine plants, twice the length of the stamens in six plants, and less than twice the length of the stamens in seven plants. In contrast, the tepals of *E. ciliata* were usually more than twice the length of the stamens (12 of 17 specimens), and those of both *E. herrerae* and *E. weberbaueri* were usually less than twice the length of the stamens (40 of 41 plants from 18 populations and 11 of 14 flowers from seven plants, one population, respectively).

Etymology. The specific epithet describes the denticulate margins of the basal leaves, which help to differentiate this species from its Peruvian relatives.

Paratypes. COLOMBIA. *Moritz 1203* (BM). **Boyacá:** Sierra Nevada del Cocuy, near Laguna de San Pablin, *Grubb, Curry & Fernandez-Perez 117* (K), *Grubb, Curry & Fernandez-Perez 122* (K); W slope above Villa de Leyva, *Melampy 974* (MO). **Cundinamarca:** Bogotá, 1855, *Triana s.n.* (BM); S of Usme, betw. La Regadera & El Hato, Estación Agrícola Exp. Usme, *Idrobo 410* (COL, US [2]); Mpio. de Mosquera, Zanjón–Las Cátedras, *Saravia 01031* (COL), *Saravia 01048* (COL); 30 km NW of Bogotá, Vereda de Roza, 4 km S of Cota, *Fassett 25660* (NY, US); Guasca, *Arbelaez 1134* (COL, US); Ubaté, 100 km N of Bogotá, *Køie 4521* (C, US); “Terreros” [Bosa], *van der Hammen 469* (COL); S end of Suba Hill, near Bogotá, *Schiefer 881* (DS, GH). VENEZUELA. **Mérida:** betw. Apartaderos & Santo Domingo, *Lasser & Adams 4542* (VEN); betw. Santo Domingo & Chachopo, *Jahn 1122* (US); Mucurubá, *Gehriger 295* (F, MO, US [2]); near Mucurubá, Páramo del Chorro, Hacienda de Cacute, *Aristequieta 3284* (NY, VEN); Páramo de Mucubají, near Laguna Grande, *Schulz, Rodríguez & Sánchez 105* (U); head of Río Santo Domingo, Finca La Corcavada, *Schulz & Rodríguez 681* (U).

3. *Echeandia herrerae* (Killip) Cruden, comb. nov.

Basionym: *Anthericum herrerae* Killip, J. Wash. Acad. Sci. 16: 566. 1926. TYPE: Peru. [Cuzco:]

Paucartambo, Hacienda Churú, 3500 m, Jan. 1926, *F. L. Herrera 1012a* (holotype, US!). Figure 1.

Storage areas of roots enlarged 0.5–1.5 cm from the rhizome, 1.5–3 cm long. Basal leaves (4 to)6 to 12(to 14), 3–18(–22) cm × 3–10 mm, usually falcate, spreading, the margins densely short-ciliate to densely ciliate, or rarely densely denticulate or densely long-ciliate; cauline leaves 0 or 1, if present 6–37 mm long. Scapes 1 or 2(to 5), 3–26(–ca. 45) cm high, weakly to strongly scabrescent toward the base with well-developed enations, occasionally scabrous or scabrescent throughout, rarely glabrous or nearly so, height usually less than twice the length of the longest basal leaf, unbranched or rarely 1- or 2-branched; main axis of inflorescence with (2 or)3 to 11(to 13) flowering nodes, lowest nodes 1- or 2-flowered, upper 1-flowered. Flowers yellow, erect; pedicels 2.5–6(–7) mm; tepals 9–13(–15) mm, usually less, rarely more than twice the length of the stamens, probably spreading, inner 4–6 mm wide; filaments 4.5–6.5(–7) mm long, ± straight, inserted in a shallow pit, usually smooth or wrinkled and scaleless, occasionally bearing small, narrow, transverse scales; anthers free, 1–2(–2.5) mm, versatile, usually becoming curved or twisted during or after dehiscence, dehiscence lateral; ovary 2–4.5(–5) mm; style 2–6 (–6.5) mm, geniculate, the stigmas exerted to 2(–2.5) mm lateral to the stamens, rarely straight and the stigma equal to or barely exceeding the anthers. Capsules oblong to narrowly oblong, 7–15 × 4–6 mm.

Distribution and habitat. This species is widely distributed on the east side of the Andes in Peru from Junín south to Apurímac and Cuzco between 2800 and 3824 m (Fig. 1). It inhabits dry, rocky, or gravelly hillsides, pampas, fallow fields, pastures, and, occasionally, more mesic habitats.

Phenology. In flower December to April.

Discussion. Plants of *Echeandia herrerae* are distinguished by a number of floral and vegetative traits, which separate them from the other South American species of *Echeandia*. Most specimens were easily identified by their short (3–26[–ca. 45] cm high), scabrescent to scabrous scapes, which were usually one to two times the length of the longest basal leaf, and/or the densely short-ciliate to ciliate leaf margins (52 of 65 specimens from 27 collections). Occasional specimens had either long-ciliate (four specimens) or denticulate/short-ciliate (nine specimens) leaf margins. Flowering plants were easily identified by the erect flowers, short, geniculate, rarely straight styles, and short pedicels (2.5–6[–7] mm long). The latter were probably too short to

accommodate the bending that occurred in the pedicels of the flowers of *E. ciliata* and *E. weberbaueri*, which have flowers that are cernuous or patent and pedicels that are (4–)5–14(–15) mm long.

The erect flowers and shorter (2–6[–6.5] mm vs. [5.5–]6–11 mm long), geniculate styles distinguished this species from the other South American *Echeandia*. Regardless of the inclination of their flowers, the styles of the other species were straight, arcuate or somewhat declinate, and exerted well beyond their anthers. Also, the scapes of *E. herrerae* were, in general, shorter than those of the other Peruvian species (3–26[–ca. 45] cm vs. [8–]15–62[–85] cm high), and those of half the specimens (42 of 80) were noticeably scabrescent to scabrous, whereas the scapes of *E. ciliata* and *E. weberbaueri* were either smooth or minutely to weakly scabrescent near the base. Because they are geographically sympatric, *E. herrerae* and *E. weberbaueri* might be confused. In addition to its geniculate styles, *E. herrerae* had shorter scapes (3–26[–ca. 45] cm vs. 34–59[–68] cm high) and shorter, versatile anthers (1–2[–2.5] mm vs. [2–]2.5–4 mm long) that twist during or after dehiscence rather than being nonversatile and remaining straight after dehiscence. Further, *E. herrerae* occurred at higher elevations (2800–3824 m vs. 2300–2700 m).

Etymology. The specific epithet honors Fortunato Lucian Herrera y Garmendia (1875–1945), well-known Peruvian botanist and professor of botany at the Universidad Nacional San Antonio Abad del Cuzco, who collected extensively in the region around Cuzco.

Additional specimens examined. PERU. Jan. 1864, *Pearce s.n.* (K). **Apurimac:** Quebrada, 2 km N of Andahuaylas, *Stork & Horton 10722* (F, G, K, MO, UC); Challhuanca, Aymaraes, *Núñez 7174* (MO); Abancay, Curahuasi, *Marin 1929* (F). **Cuzco:** Apurimac Valley, *Herrera 3067* (US); 13 km W of Cusco, *Ellenberg 1195* (U); Anta, Cillapuyu, El Chaccan, 28 Dec. 1972, *Brunel 204* (MO); Mar. 1973, *Brunel 621* (MO); Ancahuasi, NW Cusco, 40 km cerca Zurite, carr. a Cusco, *Núñez 7252* (MO); Calca, Huambutio, San Salvador, *Dueñas 152* (MO); Cuzco, *Herrera 2396* (F); Cuzco, *Soukup 893* (F); *Stafford 268* (K); Huasao, *Herrera 3108* (US); near Pisac, *Hunnewell 15905* (GH); Saqsayhuaman, *Gutte & Gutte 1916b* (LZ); Paucartambo, near Paucartambo, *Vargas 120* (F); Ccolcca, *Vargas 904* (F); Quispicanchis, Huarapata, *Vargas 1788* (GH); Oropeza Valley, Hacienda Guispicanchi, *Herrera 2590* (US); Urubamba, Huayllamba, entre la quebrada Huayocari, Lagunas de Yanacocha y Kellococha, *Tupayachi 900* (MO); Wachuna, rd. betw. Chinchero & Rajchi, *Davis et al. 1595* (F); rd. Chinchero to Urubamba, *Weigend & Weigend 2000/154* (MSB); Yanacona, near Perga Kachun, Q'allas, *Franquemont & Franquemont 257B* (F, MO); Valley of the Urubamba, Ollantaitambo, *Herrera 3457* (F, G). **Huancavelica:** Huancavelica, Larmes, E of Conaica, *Tovar 178* (MO, US). **Junín:** Jauja, Cerro Gloria Malca (serranias that surround Jauja),

Ochoa 275 (BH, US); Huancayo, *Soukup 3972* (COL, F, GH); Huancayo, Quebrada Occopilla, *Soukup 3641* (US); near Huancayo, *Killip & Smith 22027* (NY, US); Yauli, La Oroya, Pachacayo, *Gutte 2993b* (LZ); above the train station, *Gutte 9263a,b* (LZ).

4. *Echeandia lehmannii* (Baker) Marais & Reilly, *Kew Bull.* 32: 662. 1978. Basionym: *Anthericum lehmannii* Baker as "*lehmannii*," *Bot. Jahrb. Syst.* 8: 208. 1887. TYPE: Ecuador. Rare on alluvial [soil] near Malchinguí, S slope of [Volcán] Mojanda, 2800 m, 28 Jan. 1881, *F. C. Lehmann 429a* (holotype, BM!, fragm. K!; isotype, G!). Figure 1.

Echeandia aequatoris Ravenna, *Phytologia* 57: 327. 1985. Syn. nov. TYPE: Ecuador. Pichincha: via Mitad del Mundo–Calacalí, Hacienda Caspigasi, 7 Apr. 1979, *R. Jaramillo & D. Silva 933* (holotype, AAU not seen; isotype, QCA not seen).

Storage areas of roots enlarged 0.5–2 cm from rhizome, 1–2.5 cm long. Basal leaves 5 to 8, 8–20 cm × (3–)4–9[–10] mm, margins undulate, minutely denticulate to short ciliate; cauline leaves 1 to 3, lowest 1–6 cm long. Scape [19–]20–32(–40) cm high, glabrous or with a few small enations near the base, 0- to 2-branched; main axis of inflorescence with (5 to)9 to 16[or 17] flower-bearing nodes, lowest 2- or 3-flowered. Flowers yellow, nutant; tepals 10–15 mm, probably reflexed, inner to 5 mm wide; filaments narrowly clavate, bearing numerous small scales, [2.8–]5–6 mm; anthers connate, 4.5–5.5 mm, apex of cone deeply lobed, 0.8–1 mm across; ovary [2–]3–5 mm. Capsules oblong 8–13 × 4–4.5[–5] mm. (Measurements in brackets are from Ravenna's [1985: 327] description of *Echeandia aequatoris*.)

Distribution and habitat. Collection localities were provided for three of the four collections of this Ecuadorian endemic. Two of these were made 20–25 km north of Quito in or close to the Pululahua Geobotanical Reserve, and the third was made 25–30 km to the northeast of Quito near Malchinguí on the southern/southwestern slope of Volcán Mojanda–Fuya Fuya (Fig. 1). Elevations of 2800 and 2850 m were provided for two collections. The two areas are approximately 30 km apart. The plants were growing on alluvial soils (*Lehmann 429a*) and in open grassy areas (*Humbles 6283*).

Phenology. In flower late January to April.

Discussion. The combination of yellow flowers and connate anthers distinguishes *Echeandia lehmannii* from the other South American species.

There is no evidence that this species occurs other than in a small area north of Quito. The limited range and few collections suggest that *Echeandia lehmannii*

is a narrow endemic and quite rare. The Lobb collection (*Lobb* 33 [K]) is undoubtedly mislabeled, as numbers of his specimens from Peru and Ecuador were labeled "Columbia" (Killip, 1934).

Nomenclature. I have included *Echeandia aequatoris* as a synonym of *E. lehmannii* because there are no obvious and/or substantive differences between them. Ravenna's observation (1985: 327) that "the species [*aequatoris*] represents the first record of *Echeandia* from Ecuador" suggests that he was unaware of Marais and Reilly's (1978) transfer of Baker's species into *Echeandia*. Given the geographic proximity of the few populations, there is reason to question whether *E. aequatoris* represents a distinct species. A comparison of the protologue of *E. aequatoris* with the few available specimens of *E. lehmannii* revealed no substantive differences between the two. For most traits, the variation observed by Ravenna (1985) was included within the variation I observed, and the few exceptions provide minimal extensions of the ranges of those traits, e.g., leaf width from 3–9 to 3–10 mm (see above). The one exception might be filament length, but equivalent variation exists in other species (e.g., *E. leucantha*). Also, it seems quite unlikely that two morphologically similar, quite rare species would occur within a few kilometers of one another. Finally, the holotype of *E. aequatoris* was on loan and unavailable for study as of June 2001 and September 2004 (Nørgaard, pers. comm.; Balslev, pers. comm.). Renato Valencia Reyes confirmed the presence of the isotype at QCA.

Etymology. The specific epithet honors Friedrich Carl Lehmann (1850–1903), who collected widely in Latin America and made the first collection of this and other species now included in *Echeandia*.

Additional specimens examined. COLUMBIA [sic]. *Lobb* 33 (K). ECUADOR. **Pichincha:** Pululahua Crater, ca. 22 km N of Quito, *Humbles* 6283 (F, MO [2]).

5. *Echeandia weberbaueri* (Poelln.) Cruden, comb. nov. Basionym: *Anthericum weberbaueri* Poelln., *Revista Sudamer. Bot.* 7: 103. 1942. TYPE: Peru. Huancavelica: Tayacaja, valley of the Mantaro River below Surcubamba, 2300–2400 m, 14 Mar. 1913, A. *Weberbauer* 6481 (holotype, B! [image examined online]; isotypes, DS!, F!, GH! [2], NY!, US! [2]). Figure 1.

Storage areas of roots enlarged 0.5–1.5 cm from the rhizome, 1.5–3 cm long. Basal leaves 7 to 12(to 16), (6.5–)10–25(–33) cm × (3–)6–12 mm, flat, occasionally falcate, margins ciliate to long-ciliate (*Weberbauer* 6481) or denticulate to short-ciliate (*Tovar* 4001); cauline leaves 0 to 2, if present, the lowest 16–35

(–49) mm. Scape 1(to 3), 34–59(–68) cm high, frequently (8 of 12 plants) more than twice the length of the longest basal leaf, smooth or nearly so, occasionally minutely scabrescent toward the base, sometimes with 1(or 2) few-flowered branches; main axis of inflorescence with (4 to)7 to 15 flower-bearing nodes, lowest nodes 1-, 2(or 3)-flowered, upper 1- or 2-flowered. Flowers yellow, cernuous to patent; pedicels 6–14(–15) mm; tepals 11–16.5(–18.5) mm, usually less than twice the length of the stamens, probably spreading to somewhat reflexed, the inner tepals 5–8 mm wide; filaments 6–7 mm, ± straight, smooth, occasionally wrinkled and scaleless or bearing tiny, narrow, transverse scales; anthers free, (2–)2.5–4 mm, straight to reniform, non-versatile, the anther walls strongly reflexed holding the anther on the same axis as the filament (cf. *Weberbauer* 6481 [GH, NY, US]), rarely versatile or apparently so, occasionally twisted or strongly curved, dehiscence lateral; ovary 2–3(–3.5) mm; styles 7–11 mm, straight to gently deflexed (to 30°), turned upward below the stigma, the stigma exerted (2–)3–5(–6) mm beyond the anthers. Capsules narrowly oblong, 12–13.5 × 4.5–5.5 mm.

Distribution and habitat. This Peruvian species is known from two collections made 5–10 km from one another in or near the valley of the Río Mantaro in Huancavelica, ca. 60 km east of Huancayo (Fig. 1), between 2300 and 2700 m. The available data suggest it is a species of open hillsides and cultivated land.

Phenology. In flower February to April.

Discussion. Plants of *Echeandia weberbaueri* were distinguished by their tall scapes (34–59[–68] cm high), flat, relatively broad ([3–]6–12 mm wide) basal leaves, some of which had long-ciliate margins (*Weberbauer* 6481) and long ([2–]2.5–4 mm), straight, nonversatile anthers, whose strongly reflexed walls held the anthers on the same axes as their filaments.

The wide, flat basal leaves and long, nonversatile anthers of *Echeandia weberbaueri* helped to distinguish it from *E. denticulata* and the other Peruvian species. The anthers usually remained straight rather than twisting during or after dehiscence and were longer than the versatile anthers of the other Peruvian species ([2–]2.5–4 mm vs. 1–2.5 mm long), whose anthers usually became twisted during or after dehiscence. Compared to *E. denticulata*, the filaments of *E. weberbaueri* were mostly smooth and/or scaleless (13 of 14 plants) and those of one plant bore small, narrow, transverse scales, whereas the filaments of *E. denticulata* were noticeably scaled. Compared to *E. ciliata*, the basal leaves of *E. weberbaueri* were, in general, flat and wider than the falcate basal leaves of

E. ciliata ([3–]6–12 mm vs. [1–]2–7[–9] mm wide). The tepals of *E. weberbaueri* were generally less than twice the length of the stamens (12 of 15 plants), whereas those of most specimens of *E. ciliata* were twice or more than twice the length of the stamens (13 of 15 plants). Also, the scapes of most plants of *E. ciliata* were three to four times the length of the longest basal leaf, whereas those of *E. weberbaueri* were mostly less than twice the length of the longest basal leaf. Specimens of *E. weberbaueri* were easily distinguished from those of *E. herrerae*, with which it is geographically sympatric (Fig. 1). The scapes of *E. herrerae* were shorter (3–26[–ca. 45] cm vs. 34–59 [–68] cm high), frequently scabrescent to scabrous, the anthers shorter (1–2[–2.5] mm vs. [2–]2.5–4 mm), the styles shorter (2–6[–6.5] mm vs. 7–11 mm) and geniculate, and it occurred at higher elevations (2800–3824 m vs. 2300–2700 m).

Etymology. The specific epithet honors August Weberbauer (1871–1948), German-educated botanist and professor of botany at the Universidad Nacional Mayor de San Marcos in Lima, Peru, who made the first collection of this species.

Additional specimen examined. PERU. **Huancavelica:** Tayacaja, near Huachocolpa, *Tovar 4001* (US).

Ib. Subgenus *Mscavea* Cruden, *Novon* 9: 326. 1999.
TYPE: *Echeandia mcvaughii* Cruden, *Contr. Univ. Michigan Herb.* 16: 129. 1987.

Flowers white, occasionally cream-colored, yellow, or orange; inner tepals narrowly elliptic; flowers opening in late morning or early afternoon and closing near dusk (see Cruden, 1999). The subgeneric epithet honors Marion Stilwell Cave (1904–1995), distinguished embryologist and student of the Liliaceae s.l. (see Constance et al., 1996).

6. *Echeandia bolivarensis* Cruden, *Ann. Missouri Bot. Gard.* 76: 350. 1989. TYPE: Venezuela. Bolívar: Igneous forested slopes, Serranía de Pijiguaos, 160 km SW of Caicara del Orinoco, 6°35'N, 66°45'W, 100–125 m, 12 Sep. 1985, *J. Steyermark, B. Holst & B. Manara 131761* (holotype [2 sheets], MO3472626!, MO3472627!; isotype, UC!). Figure 1.

Storage areas of roots enlarged (1–)3–6 cm from the rhizome, 3–5(–6) cm long. Basal leaves 6 to 10, ascending, narrowly lanceolate above the base, minutely denticulate-serrulate, mostly 45–60 cm × 11–18 mm; cauline leaves 4 or 5, the lowest 10–19 cm, long attenuate. Scape glabrous, 98–118 cm high, 1- to 5-branched; main axis of inflorescence with 9 to 14 flower-bearing nodes, the lower 4-flowered,

the upper 2- or 3-flowered. Flowers yellow; tepals 10–11 mm, inner ca. 3.5 mm wide; filaments linear, 6.5 mm long, sparsely to noticeably scaled with tiny to small scales, inserted ± basally in a deep pit; anthers free, 2.4–4 mm, somewhat flared basally, nonversatile, dehiscence apical; ovary 2–2.5 mm; style 7–8.5 mm. Capsule broadly oblong, 10–11 × 6.5–7.5 mm. Seeds 2.5–3 mm across.

Distribution and habitat. This Venezuelan endemic is known from just two collections made between 100 and 600 m in the Serranía de Pijiguaos at 6°35'N, 66°45'W and 6°34'N, 66°47'W, respectively, a little west and southwest of Los Pijiguaos (6°35'N, 66°44'W) in western Bolívar (Fig. 1). The type gathering was made on an open rock face in the forest, and *Gröger & Berg (1064)* reported it growing in cushions of *Selaginella* P. Beauv. among *Vellozia tubiflora* (A. Rich.) Kunth.

Phenology. In flower late July to September.

Discussion. This species is easily distinguished from other South American *Echeandia* by the combination of yellow flowers, relatively short tepals (10–11 mm long), free, nonversatile anthers, tall (98–118 cm) scapes, and roots with long (4–5 cm) storage areas that are enlarged 4–5 cm from the rhizome.

I have included this species in *Echeandia* subg. *Mscavea* with some hesitation because the plants are yellow-flowered, which is rare in the subgenus (Cruden, 1999). However, a number of other traits are consistent with this disposition. The insertion of the filaments is basal, or essentially so, in a deep pit. Basal insertion is uncommon in subgenus *Mscavea* (six of the other 25 species) but rare in subgenus *Echeandia* (one of 55 species). Second, the distance from the opening of the pit to the base of the anther sac is less than 0.25 mm, which is common in subgenus *Mscavea* (12 of 20 species examined) and rare in subgenus *Echeandia* (one of 19 species examined). Third, the anthers dehisce apically, as do the anthers of the other four species in subgenus *Mscavea* with free anthers, whereas in subgenus *Echeandia*, apical dehiscence occurs in only four of the 32 species with free anthers. Also, the inner tepals are ca. 3.5 mm wide and the capsules are broadly oblong, which are typical of species in subgenus *Mscavea* but uncommon or rare in subgenus *Echeandia*. Finally, *E. bolivarensis* occurs below 800 m, as do eight of the other 25 species in subgenus *Mscavea*, whereas only six of 53 species in subgenus *Echeandia* occur below 800 m and two of these occur in northeastern Mexico and/or the adjacent United States, which has a temperate climate.

Etymology. This species was named for the state in which the plants were collected.

Additional specimen examined. VENEZUELA. **Bolívar:** Los Pijiguaos, NE Campamento de Bauxiven, summit Cerro La Guacamaya, *Gröger & Berg 1064* (MO).

7. *Echeandia leucantha* Klotzsch, Allg. Gartenzeitung (Otto & Dietrich) 8: 275. 1840. TYPE: Venezuela. prope coloniam Tovar, 3500 ft., 1854–1855, *A. Fendler 1549* (neotype, designated here, GH!; isotype, K!). Figure 1.

Echeandia prolixa Woodson, Ann. Missouri Bot. Gard. 29: 325. 1942. TYPE: Panama. Panamá: Vic. of Bejuco, 7 Sep. 1942, *P. H. Allen 2962* (holotype, MO! [2]; isotype, GH!).

Storage areas of roots 2–3.5 cm, enlarged 3–6 cm from the rhizome. Basal leaves 7 to 12, (15–)27–83 cm × 6–20(–25) mm, narrowly lanceolate to broadly elliptical, frequently falcate, serrulate to short-ciliate; cauline leaves 1 to 6(or 8), lowest 2.5–17 cm. Scape (40–)65–112 cm high, glabrous, 0- to 4(or 5)-branched; main axis of inflorescence with 7 to 15(or 17) flower-bearing nodes, the lowest 2- to 4-flowered, upper 1- to 3-flowered. Flowers white, nutant; tepals 8.5–12 mm, usually reflexed; filaments scaled, linear, (2.5–)4–5 mm; anthers connate, (3.5–)4–6(–7) mm long, cone more than 1.6 mm wide, 0.8–1.2 mm wide at the apex; ovary 1.5–2.2 mm. Capsules broadly oblong, 7–9 × 4.5–5.5 mm, rarely globose, ca. 5 × 5 mm.

Distribution and habitat. This species occurs from northwestern Venezuela and adjacent Colombia (Fig. 1) north to Honduras. It inhabits savanna, woods, pastures, and roadsides usually below 1200, rarely to 1500 m.

Phenology. In flower mid-June to early September, also collected in flower 21 January 1982 (*Aymard & Ortega 821*).

Discussion. *Echeandia leucantha* is one of the two South American species in subgenus *Mscavea* that also occurs in Central America. The South American populations were white-flowered, but those in Honduras and some in Nicaragua were yellow- or orange-flowered. Specimens from South America were easily identified by the combination of white flowers, connate anthers, scaled filaments, and storage areas of the roots that develop 3–6 cm from the rhizome. The scaled filaments and storage areas that develop away from the rhizome distinguish it from *E. pittieri*, which has smooth filaments and storage areas that develop 1–2 cm from the rhizome. The Purdie (*s.n.*) collection from Colombia lacks open flowers and is included here with reservation.

Nomenclature. The Fendler specimen was selected to be the neotype because it is a complete specimen that includes roots with storage areas,

flowers (in the packet), and capsules. The collection was made less than 50 km from Maracay, i.e., the locality cited by Klotzsch (1840).

The designation of a neotype was necessary because no specimen was cited by either Klotzsch (1840) in his protologue or Otto (1840) in his Nachtrag to the protologue; the protologue was not accompanied by an illustration; and a putative type specimen was not found among the specimens examined. Klotzsch's (1840) description was based on plants growing in the Botanical Garden in Berlin from material collected by Moritz in 1836 near Maracay, Venezuela. The most likely places to find Moritz's specimen, if one were made, are B, BM, HAC, or possibly W (Stafleu & Cowan, 1981: 588). Such a specimen was not found at B (C. Oberprieler, pers. comm.; T. Raus, pers. comm.), BM (R. Vickery, pers. comm.), K (P. Wilken, pers. comm.), or W (B. Wallnöfer, pers. comm.), and I received no reply to enquiries sent to HAC.

At the time *Echeandia leucantha* was described, Otto was the gardener at B and it is possible that he made a collection of this species. If he did, it is missing at B (T. Raus, pers. comm.; C. Oberprieler, pers. comm.), and no specimen was found at GOET (J. Heinrichs, pers. comm.). The latter institution was suggested as a source for Otto's duplicates (Stafleu & Cowan, 1981: 858). Some of Moritz's Venezuelan material went to W, but any such specimens were destroyed during World War II (B. Wallnöfer, pers. comm.).

Etymology. The specific epithet describes the white flowers, which are typical of species in subgenus *Mscavea*.

Additional specimens examined. COLOMBIA. **Magdalena:** Santa Marta, *Purdie s.n.* (K); ridge E of Manaure, *Haught 4342* (NY, UC, US). VENEZUELA. 1846, *Funcke & Schlim 674* (BM, BR, G). **Carabobo:** near Valencia, *Pittier 8900* (US); Hacienda de Cura, near San Joaquín, *Pittier 7996* (US); Maracay, 1928, *Vogel 10* (SMU). **Portuguesa:** 5 km ENE of Agua Blanca, 22 km NE of Acarigua, *Steyermark & Rabe 96473* (US, VEN); Guanare, terrenos de la UNELLEZ, *Stergios & Ortega 1983* (NY, VEN), *Stergios & Aymard 5601* (MO), *Aymard & Ortega 821* (MO); Acarigua, *Burkart 17116* (VEN). **Zulia:** Perijá, *Gines 1857* (US); Kunaria, *Gines 1948* (F).

8. *Echeandia pittieri* Cruden, Phytologia 59: 379. 1986. TYPE: Panama. Chiriquí: 5 mi. S of Boquete toward David, in savanna near rocky creek, 2800 ft., 26 Aug. 1965, *S. McDaniel 6810* (holotype, MO!; isotype, DUKE!).

Storage areas of roots 1–1.5 cm, enlarged 1–2 cm from the rhizome. Basal leaves 5 to 11, (18–)29–41 cm × (4–)11–20 mm, narrowly lanceolate,

entire or short-ciliate; cauline leaves 3 to 5, the lowest 5–20.5 cm. Scape 80–115 cm high, glabrous, 0- to 2-branched; main axis of inflorescence with 9 to 15 flower-bearing nodes. Flowers white, nutant; tepals 10–12.5 mm, reflexed; filaments smooth, linear, 3–4.5 mm; anthers connate, 5.5–7 mm; ovary 2–3 mm. Capsules broadly oblong, 6.5–7.5 × ca. 5 mm.

Distribution and habitat. This species is known from two localities in Panama (Cruden, 1986b) and one in Colombia (Fig. 1). The two collections from Panama were made at ca. 850 and 1000 m and that from Colombia at 1200 m. One collection from Panama was made in a savanna near a creek, and in Colombia, the specimens were collected on a loma where it grew with shrubs. A collection from northern Colombia (*Haught 4342*) previously included in this species (Cruden, 1986b) is properly placed in *Echeandia leucantha*.

Phenology. In flower late July to August.

Discussion. This species is characterized by its white flowers, connate anthers, smooth filaments, and storage areas of the roots that develop 1–2 cm from the scape. The smooth anthers and storage areas that develop close to the rhizome distinguish *Echeandia pittieri* from *E. leucantha*, which has scaled filaments and longer storage areas (2–3.5 cm vs. 1–1.5 cm long) that develop 3–6 cm from the rhizome.

Etymology. The specific epithet honors Henri François Pittier (1857–1950), a Swiss botanist who collected widely in Colombia, Venezuela, and Central America.

Additional specimens examined. COLOMBIA. **Valle del Cauca:** W slopes of Cordillera Occidental, valley of the Río Sanjuniquín, Naranjal, *Cuatrecasas 15356* (F, US).

Literature Cited

- Augspurger, C. K. 1981. Reproductive synchrony of a tropical shrub: Experimental studies on effects of pollinators and seed predators on *Hybanthus prunifolius* (Violaceae). *Ecology* 62: 775–788.
- Baker, J. G. 1876. Revision of the genera and species of Anthericeae and Eriospermeae. *J. Linn. Soc., Bot.* 15: 253–363.
- Bernhardt, P. & E. A. Montalvo. 1979. The pollination ecology of *Echeandia macrocarpa* (Liliaceae). *Brittonia* 31: 64–71.
- Berry, P. E. 1982. The systematics and evolution of *Fuchsia* sect. *Fuchsia* (Onagraceae). *Ann. Missouri Bot. Gard.* 69: 1–198.
- Conran, J. G. 1998. Anthericeae. Pp. 114–121 in K. Kubitzki (editor), *The Families and Genera of Vascular Plants*, Vol. 3. Flowering Plants: Monocotyledons. Springer-Verlag, Berlin.
- Constance, L., D. R. Kaplan & R. Ornduff. 1996. Marion Stilwell Cave, Botany: Berkeley. Pp. 45–47 in D. Krogh (editor), *University of California: In Memoriam, 1996*. University of California, Oakland.
- Cruden, R. W. 1986a. New combinations in *Echeandia* and *Hagenbachia* (Liliaceae). *Phytologia* 59: 379–380.
- . 1986b. New species of *Echeandia* (Liliaceae) from Central America. *Phytologia* 59: 373–379.
- . 1987. *Hagenbachia*, a misplaced genus of New World Liliaceae. *Nord. J. Bot.* 7: 255–260.
- . 1994. *Echeandia*. Pp. 27–30 in G. Davidse, M. S. Sousa & A. O. Chater (editors), *Flora Mesoamericana*. Universidad Nacional Autónoma de México, México D.F.
- . 1999. A new subgenus and fifteen new species of *Echeandia* (Anthericeae) from Mexico and the United States. *Novon* 9: 325–338.
- & R. McVaugh. 1989. *Echeandia*. Pp. 178–197 in R. McVaugh (editor), *Flora Novo-Galiciana*, Vol. 15. University of Michigan Herbarium, Ann Arbor.
- Greenman, J. M. 1898. Diagnoses of new and critical Mexican Phanerogams. *Daedalus. Proc. Amer. Acad. Arts* 33: 471–489.
- Guaglianone, E. R. 1996. Liliaceae Juss. Pp. 228–240 in F. O. Zuloaga & O. Morrone (editors), *Catálogo de las Plantas Vasculares de la República Argentina. I. Pteridophyta, Gymnospermae y Angiospermae (Monocotyledoneae)*. *Monogr. Syst. Bot. Missouri Bot. Gard.* 60.
- Hauman, L. 1917. Notes floristiques, quelque cryptogames, gymnospermes et monocotylédones de L'Argentine. *Anales Mus. Nac. Hist. Nat. Buenos Aires* 29: 391–443.
- Hensold, N. 1999. Las Angiospermas endémicas del Dpto. de Cajamarca, Perú. *Arnaldoa* 6: 141–182.
- Hofreiter, A. & E. F. Rodríguez. 2005. Distribution and phenology of *Bomarea* (Alstroemeriaceae) in the relict forests of northwestern Peru. *Revista Peru. Biol.* 12: 275–282.
- Humboldt, A., A. Bonpland & C. S. Kunth. 1815. *Nova Genera et Species Plantarum*, Vol. 1. Paris. (Facsimile ed., Weinheim, J. Cramer, 1963).
- , ——— & ———. 1825. *Nova Genera et Species Plantarum*, Vol. VII. Paris. (Facsimile ed., Weinheim, J. Cramer, 1963).
- Hutchinson, J. 1959. *The Families of the Flowering Plants. II. Monocotyledons*. Clarendon Press, Oxford.
- Jackson, B. D. 1985. *Index Kewensis: An Enumeration of the Genera and Species of Flowering Plants*. Clarendon Press, Oxford, United Kingdom.
- Janzen, D. H. 1966. Synchronization of sexual reproduction of trees within the dry season in Central America. *Evolution* 21: 620–637.
- Killip, E. P. 1934. The botanical collections of William Lobb in Colombia. *Smithsonian Misc. Coll.* 87: 1–13.
- Klotzsch, Dr. 1840. *Echeandia leucantha* aus Maracay in Sudamerika. *Allg. Gartenzeitung (Otto & Dietrich)* 8: 275.
- Kunth, C. S. 1843. *Enumeratio Plantarum*, Vol. 4. J. G. Cotta, Stuttgart.
- Marais, W. & J. Reilly. 1978. *Chlorophytum* and its related genera (Liliaceae). *Kew Bull.* 32: 653–663.
- McNeill, J., F. R. Barrie, H. M. Burdet, V. Demoulin, D. L. Hawksworth, K. Marhold, D. H. Nicolson, J. Prado, P. C. Silva, J. E. Skog, J. H. Wiersema & N. J. Turland. 2006. *International Code of Botanical Nomenclature (Vienna Code)*. *Regnum Veg.* 146.
- McVaugh, R. 1955. The American collections of Humboldt and Bonpland, as described in the *Systema Vegetabilium* of Roemer and Schultes. *Taxon* 4: 78–86.

- Núñez, E. & G. Petersen G. 1970. El Peru en la obra de Alejandro de Humboldt. Libreria Studium, Lima.
- Otto, F. 1840. Nachtrag zur obigen Abhandlung. Allg. Gartenzeitung (Otto & Dietrich) 8: 275.
- Rankin Rodríguez, R. & W. Greuter. 2001. Humboldt, Willdenow, and *Polygala* (Polygalaceae). Taxon 50: 1231–1247.
- Rathcke, B. & E. P. Lacey. 1985. Phenological patterns of terrestrial plants. Ann. Rev. Ecol. Syst. 16: 179–214.
- Ravenna, P. 1985. New or critical Liliaceae. II. Phytologia 57: 327–328.
- . 1987. *Diamena* and *Diora*, two new genera of Anthericaceae from Peru. Opera Bot. 92: 185–193.
- . 1988. Six new species of *Anthericum* (Anthericaceae) from Bolivia and Peru. Onira 1(3): 24–30.
- Rusby, H. H. 1896. On the collections of Mr. Miguel Bang in Bolivia—Part III. Mem. Torr. Bot. Club 6: 1–130.
- Sagástegui, A., M. O. Dillon, I. Sánchez, S. Leiva & P. Lezama. 1999. Diversidad Florística del Norte de Perú. I. World Wildlife Fund, Lima.
- Sandwith, N. Y. 1925. XXXIV—Humboldt and Bonpland's itinerary in Venezuela. Bull. Misc. Inform. pp. 295–310.
- . 1926. XXIV—Humboldt and Bonpland's itinerary in Ecuador and Peru. Bull. Misc. Inform. pp. 181–190.
- Schultes, J. A. & J. H. Schultes. 1829. Systema Vegetabilium, Vol. 7, Part 1. J. G. Cotta, Stuttgart.
- Sprague, T. A. 1926. Humboldt and Bonpland's itinerary in Colombia. Bull. Misc. Inform. pp. 23–30.
- Stafleu, F. A. & R. S. Cowan. 1981. Taxonomic Literature, Vol. III. Lh-O. Bohn, Scheltema & Holkema, Utrecht.
- Stearn, W. T. 1968. Humboldt, Bonpland, Kunth and Tropical American Botany. A Miscellany on the "Nova Genera et Species Plantarum." Verlag von J. Cramer, Stuttgart.
- Weatherby, C. A. 1910. A preliminary synopsis of the genus *Echeandia*. Daedalus 45: 387–394.
- Weigend, M. 2002. Observations on the biogeography of the Amotape-Huancabamba zone in northern Peru. Bot. Rev. 68: 33–54.

APPENDIX 1. List of accepted species in *Echeandia* (in boldface) and associated names (in italics) listed by genus and subgenus.

Anthericum L.

- A. ciliatum* (Kunth) Spreng., nom. illeg. — ***E. ciliata***
- A. glareosum* Ravenna — ***E. ciliata***
- A. herrerae* Killip — ***E. herrerae***
- A. humboldtii* Hemsley — ***E. ciliata***
- A. lehmannii* Baker — ***E. lehmannii***
- A. weberbaueri* Poelln. — ***E. weberbaueri***

I. *Echeandia* Ortega

Ia. *Echeandia* subgenus *Echeandia*

- E. aequatoris* Ravenna — ***E. lehmannii***
1. ***E. ciliata*** (Kunth) Cruden
2. ***E. denticulata*** Cruden
3. ***E. herrerae*** (Killip) Cruden
4. ***E. lehmannii*** (Baker) Marais & Reilly
5. ***E. weberbaueri*** (Poelln.) Cruden

Ib. *Echeandia* subgenus *Mscavea* Cruden

6. ***E. bolivarensis*** Cruden
7. ***E. leucantha*** Klotzsch
8. ***E. pittieri*** Cruden

Phalangium P. Miller

- P. ciliatum* Kunth — ***E. ciliata***

APPENDIX 2. Index to exsiccatae. Holotypes, lectotypes, and neotypes are in boldface. The parentheses enclose the number of the species as it appears in the text (see Appendix 1).

Allen 2962 (7); *Arbelaez 1134* (2); *Aristequieta 3284* (2); *Aymard & Ortega 821* (7). *Brunel 204* (3), *621* (3); *Burkart 17116* (7). **Cuatrecasas 6639** (2); *15356* (8). *Davis et al. 1595* (3); *Dillon, Molau & Matekaitis 2862* (1). *Ellenberg 1195* (3). *Fassett 25660* (2); **Fendler 1549** (7); *Franquemont & Franquemont 257B* (3); *Funcke & Schlim 674* (7). *Gehriger 295* (2); *Gines 1857* (7); *1948* (7); *Gröger & Berg 1064* (6); *Grubb, Curry & Fernandez-Perez 117* (2), *122* (2); *Gutte 9263a,b* (3), *2993b* (3); *Gutte & Gutte 1916b* (3); *Gutte & Müller 9375* (1). *Haught 4342* (7); **Herrera 1012a** (3), *2396* (3), *2590* (3), *3067* (3), *3108* (3), *3457* (3); *Humbles 6283* (4); **Humboldt & Bonpland s.n.** (1); *Hunnewell 15905* (3). *Idrobo, Jaramillo, Mesa-Bernal & Smith 410* (2). *Jahn 1122* (2). *Killip & Smith 22027* (3); *Koie 4521* (2). *Lasser & Adams 4542* (2); **Lehmann 429a** (4), *8842* (2); *Lobb 33* (4); **López 1307** (1). *Marin 1929* (3); **McDaniel 6810** (8); *Melampy 974* (2); *Moritz 1203* (2). *Núñez 7174* (3), *7252* (3). *Ochoa 275* (3). *Pennell 1856* (2); *Pittier 7996* (7), *8900* (7); *Purdie s.n.* (7). *Sagástegui 15148* (1); *Sánchez Vega 3266* (1), *4278* (1); *Sánchez Vega, Flores & Leiva 5687* (1); *Sánchez Vega, Ruiz Vigo & Sánchez Vega 1846* (1); *Saravia 01031* (2), *01048* (2); *Schiefer 881* (2); *Schulz & Rodríguez 681* (2); *Schulz, Rodríguez & Sánchez 105* (2); *Soukup 893* (3), *3641* (3), *3972* (3); *Stafford 268* (3); *Stergios & Aymard 5601* (7); *Stergios & Ortega 1983* (7); *Steyermark & Rabe 96473* (7); **Steyermark, Holst & Manara 131761** (6); *Stork & Horton 10722* (3). *Tovar 178* (3), *4001* (5); *Tracey 301* (2); *Triana s.n.* (2); *Tupayachi 900* (3). *van der Hammen 469* (2); *Vargas 120* (3), *904* (3), *1788* (3); *Vogel 10* (7). **Weberbauer 6481** (5); *Weigend & Weigend 2000/154* (3); *Weigend, Dostert & Drießle 97/427* (1).

THREE NEW SPECIES AND A NOMENCLATURAL SYNOPSIS OF *URERA* (URTICACEAE) FROM MESOAMERICA¹

Alexandre K. Monroe² and Alexander Rodríguez³

ABSTRACT

Urera Gaudich. is unique among Mesoamerican Urticaceae in having bright, fleshy fruits. Within Mesoamerica, there is significant confusion over the application of many names, especially *U. corallina* (Liebm.) Wedd., *U. elata* (Sw.) Griseb., and *U. eggersii* Hieron. Three new species, *U. fenestrata* A. K. Monroe & Al. Rodr. (Costa Rica and Panama), *U. guanacastensis* A. K. Monroe & Al. Rodr. (Costa Rica), and *U. lianoides* A. K. Monroe & Al. Rodr. (Mexico, Guatemala, Honduras, Nicaragua, Costa Rica, Panama, Peru, and Bolivia), are described and illustrated on the basis of staminate flowers, staminate inflorescences, stem, leaf morphology, and habit. The affinities of the new species are discussed. The first record of ant associations for the genus is documented in relation to *U. fenestrata*. In addition, a key is presented to the 10 species of *Urera* recognized for Mesoamerica; nomenclatural review is given in which *U. mitis* (Vell.) Miq. is lectotypified; *U. baccifera* (L.) Gaudich. ex Wedd., *U. caracasana* (Jacq.) Griseb., *U. mitis*, and *Urtica nitida* Vell. are epitypified; and *Urera denticulata* Miq., *U. eggersii*, *U. subpeltata* Miq., and *U. subpeltata* var. *morifolia* Miq. are neotypified; and a list is provided of more than 900 exsiccatae from 13 herbaria.

RESUMEN

Urera Gaudich. es un género único entre las Urticáceas de Mesoamérica por presentar frutos lustrosos y succulentos. En Mesoamérica existe una confusión significativa en la aplicación de muchos de los nombres, especialmente en las especies *U. corallina* (Liebm.) Wedd., *U. elata* (Sw.) Griseb. y *U. eggersii* Hieron. Tres nuevas especies, *U. fenestrata* A. K. Monroe & Al. Rodr. (Costa Rica y Panama), *U. guanacastensis* A. K. Monroe & Al. Rodr. (Costa Rica) y *U. lianoides* A. K. Monroe & Al. Rodr. (Mexico, Guatemala, Honduras, Nicaragua, Costa Rica, Panama, Peru, Bolivia), son descritas e ilustradas sobre la base de sus flores e inflorescencias estaminadas, tallo, morfología de hojas y hábito. Las afinidades de las nuevas especies son discutidas. Se registra por primer vez la asociación de una hormiga con el género, específicamente en *U. fenestrata*. Adicionalmente se presenta una clave para las 10 especies reconocidas por *Urera* en Mesoamérica; se entrega una revisión en la cual *U. mitis* (Vell.) Miq. es lectotipificada; *U. baccifera* (L.) Gaudich. ex Wedd., *U. caracasana* (Jacq.) Griseb., *U. mitis* y *Urtica nitida* Vell. son epitypificadas; *Urera denticulata* Miq., *U. eggersii*, *U. subpeltata* Miq. y *U. subpeltata* var. *morifolia* Miq. son neotypificadas; y se suministra una lista de más de 900 especímenes existentes en 13 herbarios.

Key words: Flora Mesoamericana, IUCN Red list, Mesoamerica, *Urera*, Urticaceae.

The genus *Urera* Gaudich. comprises shrubs, trees, and vines that occur most frequently in riparian and disturbed vegetation in Mesoamerica. Within the Urticaceae, *Urera* is characterized by fleshy fruits (formed by the inflation of the tepals), penicillate or capitate stigmas, glabrous pistillodes, and hairs with bulbous bases that are stinging in some species. *Urera* has a nearly pantropical distribution (Neotropics, Africa, Australasia, and the Pacific Islands) but is absent from Asia (pers. obs.). Currently, a single species, *U. kaalae* Wawra, has a Critically Endan-

gered (CR) status, according to IUCN Red List criteria (IUCN, 2001).

Within Mesoamerican Urticaceae, *Urera* is unique in having bright fleshy fruits. It is also characterized by stems that frequently release a watery latex when cut (a trait shared with *Myriocarpa* Benth.) and, in some species, stinging, bulbous hairs. It is for these stinging hairs that the genus is most widely known, hence the widespread local name of “chichicaste,” which is derived from the Nahuatl word “tsijtsikast” meaning “to vibrate” (Bonilla A., pers. comm.). It is

¹ We are grateful to Norman Robson (BM) for help with the Latin diagnoses; Charlie Jarvis (BM) and Sandra Knapp (BM) for comments on the manuscript; Roy Gereau (MO) and Melanie Wilmot-Dear (K) for reviewing the manuscript; Rosemary Wise (OXF) for the illustrations; Victor Steinmann for sending images of type material at IEB; and the curators at BM, C, F, GH, INB, K, LL, MEXU, MO, NY, P, PMA, TEX, and US for the loan of, and access to, collections. Some of the paratype material was collected with support from Darwin Initiative grant 15/027.

² Department of Botany, The Natural History Museum, London, SW7 5BD, United Kingdom. a.monro@nhm.ac.uk.

³ Instituto Nacional de Biodiversidad, Apartado Postal 22-3100, Santo Domingo de Heredia, Costa Rica. arodriguez@inbio.ac.cr. doi: 10.3417/2006121

also from these stinging hairs that *Urera* derives its limited economic and medical importance: *U. baccifera* (L.) Gaudich. ex Wedd. is used as “living fences” in Guatemala and Costa Rica (Standley & Steyermark, 1952; Burger, 1977) and is also the focus of research for its anti-inflammatory properties (Badilla et al., 1999). In addition, *Urera* includes species that are used to treat arthritis (González, 1994; House et al., 1995), fever (House et al., 1995), hemorrhage (Guánchez, 1999), erysipelas (Guánchez, 1999), and syphilis (House et al., 1995), and species that are of moderate importance as food for Lepidoptera (Janzen & Hallwachs, 2005).

The genus *Urera* was first described by Gaudichaud-Beaupré in 1830, for which he proposed the subtribe Urerinnæ (as Urereae) of the family Urticaceae, which was later raised to tribal rank (Urereae) by Weddell (1856). This was subsequently renamed Urticeae by Friis (1989). *Urera* was expanded to include the monospecific genus *Scepcarpus* Wedd. by Friis (1989), and chloroplast DNA sequence data (*trnL-F*) suggests that *Urera* could be sister to *Poikilospermum* Zipp. ex Miq. within the Urticaceae (Monro, 2006).

Urera has attracted no monographic attention since Weddell (1856, 1869), and, to date, no subgeneric classification has been published (although Weddell did divide the species into unnamed groups according to inflorescence structure and distribution). Systematic work in *Urera* has largely resulted from localized floristic treatments in and adjoining Mesoamerica (Standley & Steyermark, 1952; Burger, 1977; Pool, 2001; Steinmann, 2005).

There are currently 138 published species epithets for the genus (The International Plant Names Index, 2008), of which 133 appear legitimate. Of these epithets, 16 have since been transferred to *Laportea* Gaudich., *Gyrotaenia* Griseb., *Dendrocnide* Miq., *Boehmeria* Jacq., and *Girardinia* Gaudich. by subsequent authors. Of the remaining 117 names, Friis (1989) estimates that there are ca. 35 good species and Pool (2001) estimates 35 to 75.

Within Mesoamerica, there are 25 specific epithets for 10 recognized species of *Urera*, and there is significant confusion over the application of many names, especially *U. corallina* (Liebm.) Wedd., *U. elata* (Sw.) Griseb., and *U. eggersii* Hieron. This, combined with a lack of regional keys, the similarity of form and habit, and the extent of overlapping variation in characters between species, has made the determination of collections difficult. The result is that a significant proportion of herbarium material from Mesoamerica is misidentified.

MATERIALS AND METHODS

This work was undertaken as part of the revision of Mesoamerican Urticaceae for the *Flora Mesoamericana* project. The definition of Mesoamerica is as given in the *Flora* (Davidse et al., 1994): a region bounded to its north by the Mexican states of Yucatán, Campeche, Tabasco, Quintana Roo, and Chiapas, and to its south by the Panama–Colombia border. In addition, material from Mesoamerica and areas adjacent to Mesoamerica (Oaxaca and Veracruz [Mexico], Greater Antilles, Colombia, Venezuela, Ecuador, and Peru) from BM, C, F, GH, INB, K, LL, MEXU, MO, NY, P, PMA, TEX, and US was examined, resulting in 995 collections that were examined and determined, 850 from Mesoamerica. Determinations are listed in Appendix 1. The nomenclatural revision was based on the examination of the original published descriptions for all 24 accepted names, as well as type material.

The macro-morphological characters used most frequently by previous authors for the delimitation of species are leaf shape, leaf margin morphology, inflorescence morphology and structure, trichome distribution and morphology, fruit size and color, cystolith shape, and stigma shape. In this study, emphasis was also placed on stem morphology and habit, together with personal observations in the field that some species release a thin, watery latex when cut. Although no reference to this was found in the descriptions on collection labels, a number of collections had a dark stain on the rim of the cut stem. This was taken as an indication that these collections may have released a watery latex, and it is for this reason that this was noted in the observations made and in the descriptions below. All material was examined using a stereomicroscope at $\times 64$ to $\times 400$ magnification, and up to 138 observations were made for each specimen sampled. These observations were then used as a guide to delimit taxa within a morphological species concept and in the preparation of a key to the identification of the Mesoamerican species. Once species were delimited, they were then matched to type material.

TAXONOMIC TREATMENT

Urera Gaudich., Voy. Uranie 496. 1826 [1830]. TYPE (designated by Britton & Wilson, 1924: 243): *Urera baccifera* (L.) Gaudich. ex Wedd., Ann. Sci. Nat., Bot., sér. 3, 18: 199. 1852.

Scepcarpus Wedd., Prodr. (DC.) 16(1): 98. 1869. TYPE: *Scepcarpus manni* Wedd.

KEY TO THE MESOAMERICAN SPECIES OF *URERA*

Distributions for each species are given to country level within Mesoamerica, with the exception of Mexico and species that are only known from a single country, in which case they are given to state level. Global distributions in the key are given to regional level (e.g., South America, West Indies), following *Flora Mesoamericana* protocols (Davidse et al., 1994). Some of the characters in the following keys, e.g., cystoliths, are only visible in dried material. Several types of hairs (i.e., bulbous, straight, and curved) are found on the surface of the leaves and young stems of Mesoamerican *Urera*. Here I define bulbous hairs as those with a swollen and inflated base giving the base a bulbous or bottle-shaped appearance.

- 1a. Leaves lobed; stem releasing white latex when cut 7. *U. laciniata*
 1b. Leaves not lobed; stem releasing latex or not; when released, latex gray (never white).
 2a. Stem and leaves with spines; leaves coarsely dentate, the teeth spaced every ca. 0.5–1 cm; achene 2–3.2 mm; tepals covering the basal 1/4 or less of achene prior to the inflation of tepals 1. *U. baccifera*
 2b. Stem and leaves lacking spines; leaves dentate, crenate, or entire, when toothed the teeth spaced < 0.5 cm apart; achene 0.75–2 mm; tepals covering 3/4 or more of the achene prior to the inflation of the tepals.
 3a. Adaxial surface of leaves sparsely pubescent or glabrous.
 4a. Leaf margin shallowly crenate, crenate-serrate, sinuate, or entire; hairs never urticating.
 5a. Shrub or small tree; leaf-bearing section of stem never hollow.
 6a. Ratio of leaf length to width less than 4:1; abaxial leaf surface without domatia in the axils of the secondary veins; mature fleshy fruits pink or orange to orange-red 4. *U. glabriuscula*
 6b. Ratio of leaf length to width greater than 4:1; abaxial leaf surface with domatia in the axils of the secondary veins; mature fleshy fruits red 5. *U. guanacastensis*
 5b. Shrub, lax shrub, or vine; leaf-bearing section of stem hollow, ca. 5–10 mm diam.
 7a. Young shoots pubescent to densely pubescent, the hairs 0.125–1 mm; staminate flowers ca. 1.25 × 1.25 mm immediately prior to anthesis 8. *U. lianoides*
 7b. Young shoots sparsely pubescent or glabrous, the hairs when present 0.125–0.25 mm; staminate flowers ca. 2 × 2.5 mm immediately prior to anthesis 3. *U. fenestrata*
 4b. Leaf margin prominently serrate, crenate, or dentate; hairs urticating or not urticating.
 8a. Young stem glabrous or sparsely pubescent, the hairs ≤ 0.25 mm; stem coarsely sulcate, frequently fenestrate; stems, leaves, and petioles lacking bulbous hairs; staminate inflorescence to 110 mm; mature fleshy fruits red-pink 3. *U. fenestrata*
 8b. Young stem sparsely to densely pubescent, the hairs > 0.5 mm; stem coarsely sulcate but never fenestrate; stems, leaves, and petioles with or without bulbous hairs; staminate inflorescence to 80 mm; mature fleshy fruits orange or orange-pink.
 9a. Tertiary venation of abaxial leaf surface cream to pale green, noticeably paler than lamina; stipules forked or not forked; stem sparsely pubescent 6. *U. killipiana*
 9b. Tertiary venation of abaxial leaf surface darker or rarely paler than the lamina, where paler than the lamina pale brown to orange-brown in color; stipules not forked; stem densely pubescent.
 10a. Leaves ovate or cordiform, never obovate or lanceolate; hairs urticating
 2. *U. caracasana*
 10b. Leaves obovate, lanceolate, elliptic, or ovate, never cordiform; hairs urticating or not 9. *U. simplex*
 3b. Adaxial surface of leaves pubescent to densely pubescent.
 11a. Leaves bullate; staminate peduncle unbranched at base for 40–80 mm; pistillate peduncle unbranched at base for 27–98 mm 10. *U. verrucosa*
 11b. Leaves not bullate; staminate and pistillate peduncles unbranched at base for < 25 mm.
 12a. Leaves ovate or cordiform, never obovate or lanceolate; hairs urticating 2. *U. caracasana*
 12b. Leaves obovate, lanceolate, elliptic, or ovate, never cordiform; hairs urticating or not 9. *U. simplex*

1. *Urera baccifera* (L.) Gaudich. ex Wedd., Ann. Sci. Nat., Bot., sér. 3, 18: 199. 1852. Basionym: *Urtica baccifera* L., Sp. Pl., ed. 2, 2: 1398. 1763. TYPE: Plumier, Pl. Amer.: tab. 260. 1760 (lectotype, designated by de Rooij [1975: 302]). EPITYPE: Jamaica. Stony Hill, 13 Mar. 1898, *Fawcett 7177* (epitype, designated here, BM!).

Urera armigera (C. Presl) Miq., Fl. Bras. (Martius) 4: 192. 1853. Basionym: *Urtica armigera* C. Presl, Bot. Bemerk. (C. Presl): 110. 1844 [1845]. TYPE: Brazil. "near Rio de Janeiro," *J. Lhotsky s.n.* (lectotype, designated by de Rooij [1975: 302], PR not seen).

Urera denticulata Miq., Fl. Bras. (Martius) 4: 192. 1853. TYPE: Brazil. Minas Gerais: Viçosa, rd. E from Chacha valley, Fazenda da Creciuma, 10 May 1930, *Y. Mexia 4679* (neotype, designated here, BM!; isotype, MO not seen).

Urera baccifera var. *horrida* (Kunth) Wedd., Arch. Mus. Hist. Nat. 9: 151. 1856. Basionym: *Urtica horrida* Kunth, Nov. Gen. Sp. [HBK] (quarto ed.) 2: 41. 1817. *Urera horrida* (Kunth) Miq., Fl. Bras. (Martius) 4: 192. 1853. TYPE: Colombia. "Santander, Magdalena prope Angostura de Carare," *Humboldt & Bonpland 1639* (lectotype, designated by de Rooij [1975: 302], P!).

Urtica nitida Vell., Fl. Flumin. Icon. 10: t. 20. 1827 [1831]. TYPE: Fl. Flumin. Icon. 10: tab. 20. 1827. EPITYPE: Brazil. Mato Grosso do Sul: Mpio. Paraguai, Serra des

Araras, Fazenda Currupira, 15°10'S, 56°5'W, 24 Jan. 1995, *Dubs 1770* (epitype, designated here, K!; duplicates, E not seen, ESA not seen).

Urtica grandidentata Liebm., Kongel. Danske Vidensk. Selsk. Skr. (Trondheim) ser. 5, 2: 296. 1851. TYPE: Costa Rica. Cartago: "Irasú," Jan. 1848, A. Ørsted 14283 (lectotype, designated by de Rooij [1975: 302], C!).

An epitype is selected for *Urera baccifera* because the type illustration, although accurate, is not sufficient to support the unambiguous fixing of the name to this species. *Fawcett 7177* was chosen because it includes flowering and vegetative material that conforms to Linnaeus' (1763) description "Urtica foliis alternis, cordatis" and is from the West Indies, as was the Plumier material that formed the basis of the type illustration.

An epitype is selected for *Urtica nitida* because the type illustration, although accurate, is not sufficient to support the unambiguous fixing of the name to this species. *Dubs 1770* was chosen because it includes flowering and vegetative material that conforms to Vellozo's description and is from Brazil, as was the material that formed the basis of the type illustration.

A neotype is selected for *Urera denticulata* because, although de Rooij (1975: 302) cites *Martius s.n.* at M as lectotype for *U. denticulata*, no such collections could be traced either at M (M. Esser, pers. comm.) or BR (P. Stoffelen, pers. comm.). The collections database from the Field Museum's Department of Botany (Field Museum of Natural History, 2006), which includes the negatives of photographs of European type material taken by Macbride, does, however, include a negative (no. 8845) cited as being from a Martius collection that represents type material of *U. denticulata* at M. Such a negative cannot be considered isotype material, but it does indicate the existence of a type specimen existing prior to World War II. It may be that de Rooij based his lectotypification on this photograph or that he did see the type collection at M prior to 1975, and that this collection has since been lost. The specimen designated as neotype was selected because it includes good leaf, stem, and fruiting material and is from the same country and state as the material cited in Miquel's description.

Local names. Bringa mosa (Panama: *C. Whitefoord & A. Eddy 249*, BM), chichicaste (Guatemala: *J. A. Steyermark 38770*, F; Honduras: *P. C. Standley 20526*, F; El Salvador: *P. C. Standley 22344*, F; Nicaragua: *P. C. Standley 11202*, F), chichicaste cuyanigua (El Salvador: *P. C. Standley 21880*, GH, US), chichicaste nigra (El Salvador: *S. Calderón 1539*, NY), cow itch (Belize: *P. H. Gentle 2781*, F, GH, NY,

US), nigua, niguilla (El Salvador: *P. C. Standley 22394*, GH), ortiga (Costa Rica: *R. Anderson & S. Mori 147*, F; Panama: *P. C. Standley 30536*, US), ortiga de los caballos (Mexico: *A. Schott 796*, BM, F), rascate bien (Honduras: *A. Molina R. 868*, F, GH).

Habitat and distribution. Evergreen or seasonal forest, riparian vegetation, from sea level to 1400 m, Mexico to Panama, Colombia, Peru, Bolivia, Brazil, Paraguay.

Comments. This species most closely resembles *Urera laciniata* Goudot. ex Wedd. These species can be distinguished from each other based on the presence of latex and spines and leaf margin morphology as follows: (1) for *U. baccifera*, leaf-bearing stem releasing gray but never white latex when cut, leaf margin coarsely dentate; (2) for *U. laciniata*, leaf-bearing stem releasing white latex when cut, leaf margin deeply lobed or laciniate.

Selected specimens examined. BELIZE. **Cayo:** Chiquibul, Las Cuevas, 16°43'N, 88°59'W, *A. K. Monro 671* (BM, BRH, MO). BOLIVIA. **Cochabamba:** *A. M. Bang, N. L. Britton & H. H. Rusby 1209* (A, BM, GH, MO). COSTA RICA. **Alajuela:** Río Sarapiquí at bridge on rd. to Colonia Virgen del Socorro, 9 mi. SE of San José–Puerto Viejo hwy., 10°16'N, 84°11'W, *T. B. Croat 68307* (BM, MO). EL SALVADOR. **La Libertad:** Cordillera de Balsamó, San Julián rd., towards the Pacific, 13°41'00"N, 89°38'32"W, *A. K. Monro et al. 3676* (BM, ITIC, LAGU, MO). GUATEMALA. **Izabal:** Montañas del Mico, 4–5 km W of Santo Tomás de Castilla, *W. D. Stevens et al. 25612* (BM, MO). HONDURAS. **Atlántida:** 15°42'N, 86°51'W, *R. L. Liesner 26275* (MO). NICARAGUA. **Río San Juan:** Near Caño Chontaleño 20 km NE of El Castillo, *D. Neill & P. C. Vincelli 3589* (BM, MO). PANAMA. **Darién:** Río Cocalito, *C. Whitefoord & A. Eddy 249* (BM, MO). PARAGUAY. **Canindeyú:** Karapa, Salto a 5 km del puesto, *G. Marín, B. Jiménez & M. Chocarro P. 763* (BM, FMB). PERU. **Pasco:** Oxapampa, Distr. Huancabamba, Sector Grapanazu, limite Parque Nac. Yanachaga-Chemillen, *R. Rojas, K. Meza, J. Lingan, E. Camavilca & M. Villaran 1832* (BM, MO).

2. *Urera caracasana* (Jacq.) Griseb., *Fl. Brit. W. I.* 154. 1859. Basionym: *Urtica caracasana* Jacq., *Pl. Hort. Schoenbr.* 3: 71. 1798. TYPE: Jacquin, *Pl. Hort. Schoenbr.* 3: t. 386. 1798. EPITYPE: Venezuela. Araugua: Tovar, 1854–1855, *A. Fendler 1275* (epitype, designated here, K!).

Urera alceifolia (Poir.) Gaudich., *Voy. Uranie, Bot.* 497. 1826 [1830]. Basionym: *Urtica alceifolia* Poir., *Encycl. (Lamarck) Suppl.* 4: 227. 1816. TYPE: French Guyana. Cayenne: s.d., *Martin s.n.* (lectotype, designated by de Rooij [1975: 304], P!).

Urtica tiliifolia Kunth, *Nov. Gen. Sp. [HBK] (quarto ed.)* 2: 34. 1817, as "*tiliaefolia*." TYPE: Colombia. Bolívar: Río Magdalena, *Humboldt & Bonpland 1633* (lectotype, designated by de Rooij [1975: 306], P!).

Urera jacquinii var. *ulmifolia* (Kunth) Wedd., *Arch. Mus. Hist. Nat.* 9: 145. 1856. Basionym: *Urtica ulmifolia*

Kunth, Nov. Gen. Sp. [HBK] (quarto ed.) 2: 141. 1817.
TYPE: Colombia. Bolívar, *Humboldt & Bonpland 1427*
(lectotype, designated by de Rooij [1975: 306], P!).

Urera mitis (Vell.) Miq., Fl. Bras. (Martius) 4(1): 191. 1853.
Basionym: *Urtica mitis* Vell., Fl. Flumin. 10: tab. 19.
1827 [1831]. *Urera caracasana* var. *mitis* (Vell.) Wedd.,
Prodr. (DC.) 16: 90. 1869. TYPE: Fl. Flumin. Icon. 10:
tab. 19 (lectotype, designated here, tab. 19!). EPI-
TYPE: Brazil. Amazonas: Marapata, Municipality of
Carauary, 25 May 1933, *B. Krukoff 4568* (epitype,
designated here, BM!).

Urera corallina (Liebm.) Wedd., Prodr. (DC.) 16: 90. 1869.
Basionym: *Urtica corallina* Liebm., Kongel. Danske
Vidensk. Selsk. Skr., Naturvidensk. Math. Afd., ser. 5,
2: 295. 1851. TYPE: Costa Rica. Alajuela: Monte
Aguacate, *Ørsted 14282* (lectotype, designated by de
Rooij [1975: 304], further designation here, C sheet
“26/2003/2”!).

Urera capitata Wedd., Ann. Sci. Nat., Bot., ser. 3, 18: 201.
1852. TYPE: Bolivia. Yungas: Dec. 1846, *Weddell*
4317 (holotype, P!).

Urera subpeltata Miq., Fl. Bras. (Martius) 4(1): 189, pl. 66.
1853. *Urera jacquinii* var. *subpeltata* (Miq.) Wedd.,
Arch. Mus. Hist. Nat. 9: 145. 1856. *Urera caracasana*
var. *subpeltata* (Miq.) Wedd., Prodr. (DC.) 16: 90. 1869.
TYPE: Brazil. Bahia: 1839, *Blanchet 927* (neotype,
designated here, BM!; isotype, G not seen).

Urera subpeltata var. *morifolia* Miq., Fl. Bras. (Martius) 4(1):
190. 1853. TYPE: Brazil. Pará: Santarem, July 1850, *R.*
Spruce s.n. (neotype, designated here, BM!).

Urera jacquinii var. *miquelii* Wedd., Arch. Mus. Hist. Nat. 9:
145. 1856. *Urera caracasana* var. *miquelii* Wedd.,
Prodr. (DC.) 16: 90. 1869. TYPE: Peru. *Gay s.n.*
(holotype, P not seen).

Urera acuminata Miq., Fl. Bras. (Martius) 4(1): 190. 1853,
nom. illeg. non *Urera acuminata* (Poir.) Gaudich.

Jacquin's original description of *Urera caracasana* is based solely on staminate material. Original material for the name has not been located at BM or LINN, and any material that may have been at W has probably been destroyed (material could not be traced at W). Based on the type illustration, it is not possible to distinguish between *U. caracasana* and *U. corallina* (Liebm.) Wedd. on sterile characters alone. Material examined that had been determined as *U. corallina* (including the holotype) by Weddell and as *U. caracasana* did not uncover any significant morphological differences. An epitype is selected because the type illustration, although accurate, is not sufficient to support the unambiguous application of the name to this species.

A lectotype is designated for *Urtica mitis* Vell. because Vellozo (1827) does not refer to the plate as type material as his description predates the type concept. Tabulae 19 can be considered original type material. An epitype is selected for *Urera mitis* because the type illustration, although accurate, is not sufficient to support the unambiguous fixing of the name to this species. The epitype was selected because it includes both leaves and inflorescences

and is from the same country and region as the holotype.

A neotype is selected for *Urera subpeltata* var. *morifolia* because although de Rooij (1975: 306) cites *Spruce 633* (M) as lectotype, no Spruce collection fitting this description could be traced either at M (M. Esser, pers. comm.) or BR (P. Stoffelen, pers. comm.). Miquel (1853: 190), in his original description, cites two collections from the Brazilian Amazon, “Martius in silvis amazonicis, ad Barra do Río Negro” and “Spruce ad Santarem,” neither of which could be traced either at M (M. Esser, pers. comm.) or BR (P. Stoffelen, pers. comm.). A Spruce collection was, however, located at BM with the annotation, “In vicinibus Santarem, Prov. Pará.” This is selected as neotype on the basis that the collection is from the same collector, country, and state and includes good leaf, pistillate, and immature fruit material.

A neotype is selected for *Urera subpeltata* because although de Rooij (1975: 306) cites *Martius s.n.* at M as lectotype for *U. denticulata*, no such collections could be traced either at M (M. Esser, pers. comm.) or BR (P. Stoffelen, pers. comm.). The specimen designated as neotype was selected because it includes good leaf, stem, and pistillate and staminate material and is from the same country and state as the material cited in Miquel's 1853 description.

De Rooij (1973: 306) cites *Makin s.n.* (not traced) as type (holotype?) for *Urera jacquinii* var. *miquelii*. Weddell (1856), however, cites only Claude Gay's collection from Peru in his description and this is maintained as holotype.

Local names. Chichicaste (El Salvador: *E. Sandoval 1854*, BM; Nicaragua: *P. C. Standley 10712*, F), chichicaste blanco picante (El Salvador: *E. Sandoval & R. Chinchilla 504*, MO), chichicaste cujanigua de altura (El Salvador: *E. Sandoval & R. Chinchilla 1182*, MO), chichicaste rojo picapica (El Salvador: *O. Martinez s.n. (ISF225)*, MO), pan caliente (Honduras: *C. Nelson et al. 3955*, BM), migirillo (Costa Rica: *A. Sanchez 10*, F), miguito (Costa Rica: *J. A. Echeverria C. 268*, F), ortiga (Costa Rica: *J. A. Echeverria C. 268*, F), pan caliente (El Salvador: *M. L. van Severen 113*, F), zulsimtezla (Mexico: *A. Méndez G. 8945*, BM).

Habitat and distribution. Cloud forest, shade coffee forest, pine forest, *Quercus* L.–*Liquidambar* L.–*Pinus* L. forest, from sea level to 2300 m. Mexico (Chiapas), Belize, Guatemala, Honduras, El Salvador, Nicaragua, Costa Rica, Panama, Colombia, Venezuela, Ecuador, Peru, Bolivia, Brazil, and Argentina.

Comments. Herbarium material of this species is commonly determined as *Urera corallina*. This species

most closely resembles *U. verrucosa* (Liebm.) V. W. Steinm. The two species can be distinguished from each other based on leaf texture and inflorescence peduncle size as follows: (1) for *U. caracasana*, leaves chartaceous, staminate peduncle branched to base or unbranched at base for 2–13 mm, pistillate peduncle branched to base or unbranched at base for 2–20 mm; (2) for *U. verrucosa*, leaves bullate, staminate peduncle unbranched at base for 40–80 mm and densely pubescent, pistillate peduncle unbranched at base for 27–98 mm.

Selected specimens examined. ARGENTINA. **Jujuy:** San Pedro, Sierra Sta. Barbara, S. Venturi 9633 (K). BELIZE. **Cayo:** Caracol Maya ruins, 14 km W of Las Cuevas, 16°45'N, 88°07'W, T. Hawkins 1132 (BM, MO). BOLIVIA. **Cochabamba:** Carrasco, ca. 11 km below Sehuencas, J. R. I. Wood 10275 (BM, K). BRAZIL. **Roraima:** Ilha de Maracá, SEMA Ecological Reserva, S of Cachoeira de Fumaça, W. Milliken 546 (K). COSTA RICA. **Puntarenas:** W. Haber & W. Zuchowski 9294 (MO). ECUADOR. s. loc., Eggers 15611 (K). **Pichincha:** new Alluriquin–Quito rd., Km 4, P. J. M. Maas & L. Cobb 4770 (K). EL SALVADOR. **La Libertad:** Mpio. Antiguo Cuscatlan, “Laderas de La Laguna,” P. Lemus s.n. “WB-01217” (BM, LAGU, MO). GUATEMALA. **Jutiapa:** D. Dunn et al. 23234 (MO). HONDURAS. **Ocatepeque:** Alrededores de Belén Gualcho, C. H. Nelson, E. Romero, A. Rubio & M. Pereira 3955 (BM, MO). MEXICO. **Chiapas:** Rancho Puy Ukum, sobre la carr. a 2 km de Bochil, Mpio. de Bochil, A. Méndez G. 8945 (BM, MEXU). NICARAGUA. **Jinotega:** “El Recreo,” 4 km al N de Sta. Gertrudis, P. Moreno & J. C. Sandino 7897 (BM, HNMN). PANAMA. **Chiriquí/Bocas del Toro:** Along Continental Divide on trail in Zona Palo Seco, 08°47'N, 82°13'W, S. Knapp & J. Mallet 9169 (BM, MO, PMA, SCZ). PERU. **Loreto:** Río Itaya, T. B. Croat 18829 (K). VENEZUELA. **Falcón:** Sierra de San Luis, ca. del Puente de Jobo entre Curimagua y San Luis, J. A. Steyermark 99249 (K).

3. *Urera fenestrata* A. K. Monro & Al. Rodr., sp. nov. TYPE: Costa Rica. Guanacaste: Monteverde, Cordillera de Tilarán, Pacific slope, above Quebrada Cuecha, 1540–1600 m, 6 May 1976, V. J. Dryer 179 (holotype, F!; isotype, CR!). Figure 1A–E.

Species nova *Urerae caracasanae* (Jacq.) Griseb. similis, sed ab ea floribus staminatis tetrapartitis, ramulis petiolisque espinosis ramulis saepe fenestratis atque foliorum nervis lateralibus per 2/3 longitudinis visibilibus differt.

Shrub, lax shrub, vine, or small slender tree, dioecious (?). Main stems arching 2–10 m, stems not releasing white latex when cut; without spines; young shoots glabrous or sparsely pubescent, the hairs 0.125–0.25 mm, erect, straight to weakly curved; internodes of leaf-bearing sections of stem 9–30 × 4–10 mm, pale brown to red-brown, coarsely sulcate, hollow, and frequently fenestrate when > 5 mm diam. Stipules 5–18 mm, lanceolate, not forked, pubescent; petioles 52–350 × 1.5–1.75 mm, glabrous or sparsely

pubescent, the hairs 0.25–0.5 mm; leaf blade 103–320 × 64–220 mm, ovate, broad-ovate, or broad-elliptic, chartaceous; adaxial surface sparsely pubescent or glabrous, the hairs 0.375–0.675 mm, weakly appressed, weakly curved or crooked; the cystoliths punctiform to oblong, radially arranged; abaxial surface sparsely pubescent to pubescent, the hairs 0.25–0.5 mm, appressed, weakly curved; the cystoliths oblong, parallel to veins; primary veins 3, primary to quaternary or hexternary veins visible to the naked eye, the lateral primary veins visible for 2/3 of the leaf length; domatia not present in the axils of the secondary veins; base cordate or obtuse; margins entire or weakly crenate to serrate; apex subcuspidate to cuspidate. Peduncular bracts 2–3 mm; bracteoles 0.375–0.5 mm; staminate inflorescences 1 to 16 per stem, peduncle branched to base or unbranched from base for 2–21 mm, pubescent, the hairs to 0.125 mm, the whole inflorescence 15–110 mm, bearing 160 to 350 flowers in a symmetrical cyme with 3 or 4 orders of dichotomous branching; the flowers borne in clusters of 10 to 35, pedicellate to sessile, the pedicels when present to 0.5 × 0.125 mm. Pistillate inflorescences 1 to 4 per stem, the peduncle branched to base or unbranched at base for 2–26 mm, pubescent, the hairs ca. 0.125 mm, erect, straight, the whole inflorescence 10–80 mm (47–80 mm in fruit), broader than long (or as long as broad), bearing 224 to 750 flowers in a symmetrical cyme with 5 orders of dichotomous branching, the flowers borne in clusters of 3 or 4, pedicellate to sessile, the pedicels when present to 0.25 × 0.125 mm, glabrous. Staminate flowers 2–2.5 × 1.25–1.5 mm immediately prior to anthesis; tepals 4, ca. 3 mm; stamens 2.5–3 mm; pistillode ca. 0.5 mm diam., glabrous. Pistillate flowers ca. 1 × 0.5 mm, the lateral tepals 0.5–0.675 mm, asymmetrically ovate; the dorsal tepal 0.50–0.675 mm, ovate, with a subapical dorsal thickening, the ventral tepal ca. 0.375 mm, ovate; stigma penicillate, erect. Fruit prior to inflation of tepals ca. 1.25 × 1 mm; basal 3/4 of achene obscured by tepals, the laterals ca. 1 mm, the dorsal tepal 0.675–0.75 mm, the ventral ca. 0.5 mm; achene 0.75–1 × 0.75 mm, asymmetrically elliptic, keel-shaped, surface smooth. Fruit when ripe with tepals inflated and berry-like, ca. 1.5 × 1 mm, red-pink, red-violet, pink, or orange when fresh.

Local names. Ortíga (A. Smith 100, F, NY).

Habitat and distribution. *Urera fenestrata* is found in premontane, montane, and cloud forest, frequently in disturbed shaded areas close to streams or small rivers, at 800–3000 m. It occurs on the Pacific and the Caribbean slopes of the Cordillera de Tilarán in Costa Rica and the Cordillera de Talamanca in Costa Rica and Panama.

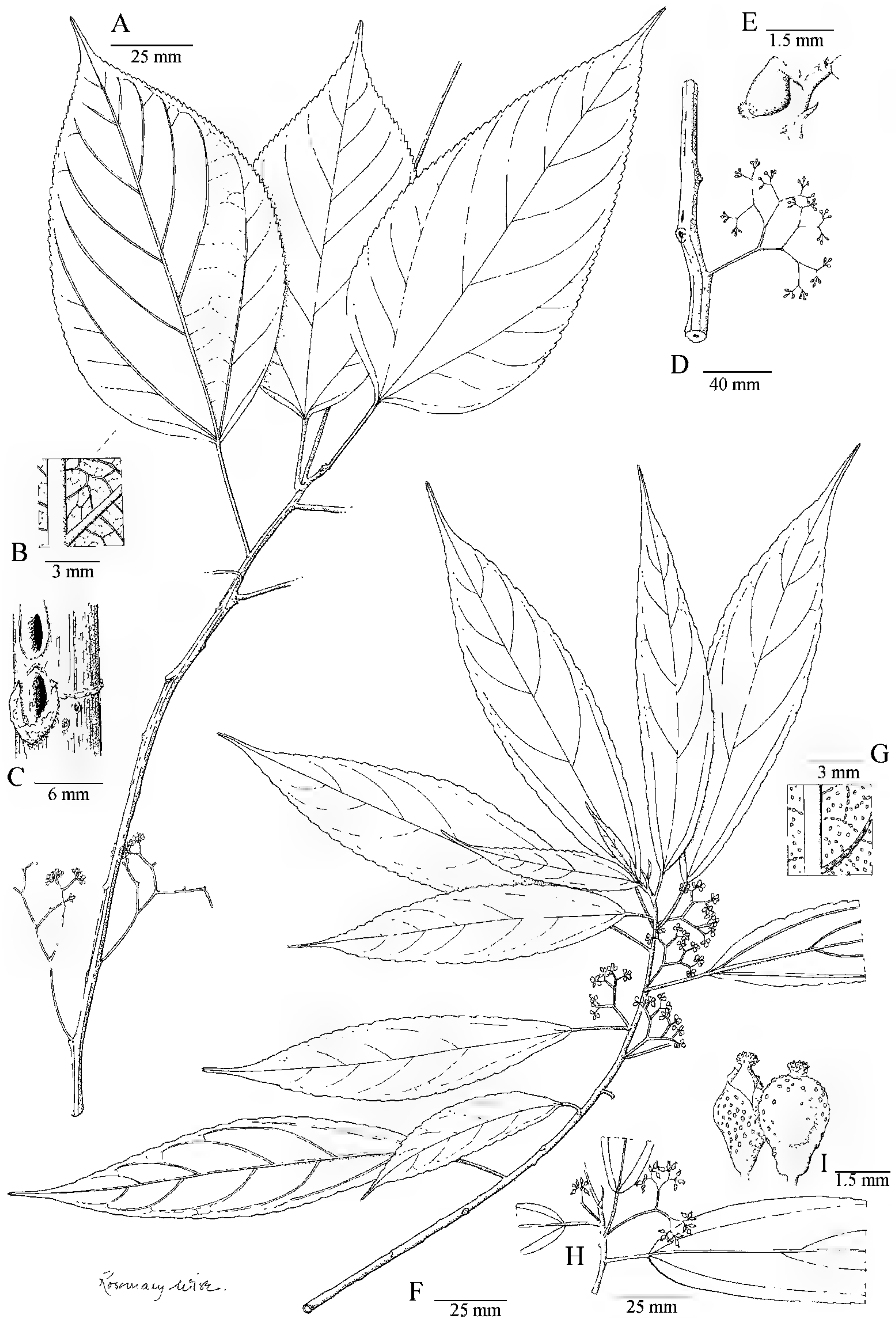

Figure 1. A–E. *Urea fenestrata* A. K. Monro & Al. Rodr. —A. Habit, with staminate inflorescences. —B. Leaf abaxial surface. —C. Stem. —D. Pistillate inflorescence. —E. Pistillate flower. (A, B: Dryer 179 [F]; C–E: Kirkbride & Duke 770 [NY]). F–I. *U. guanacastensis* A. K. Monro & Al. Rodr. —F. Habit, with staminate inflorescences. —G. Leaf adaxial surface. —H. Pistillate inflorescences. —I. Immature fruit. (F–I: Delgado 24 [MO]).

IUCN Red List category. Conservation for *Urera fenestrata* must be considered as Least Concern (LC) according to IUCN Red List criteria (IUCN, 2001), owing to the fact that the species has been collected 28 times in several localities in Costa Rica and Panama.

Etymology. From the Latin “fenestratus,” meaning “windowed,” referring to the stems which, when greater than or equal to 5 mm diam., become characteristically windowed.

Discussion. This species is characterized by the gnarled, windowed, leaf-bearing stem sections and the ovate, entire or subentire to weakly indented leaves. *Urera fenestrata* has most frequently been determined as *U. elata* or *U. caracasana* and may be distinguished from them as follows: (1) for *U. caracasana*, stems when greater than or equal to 5 mm diam. hollow, but never fenestrate, lacking spines; petiole lacking spines; the leaf margins serrate, serrate-dentate, or crenate-serrate to dentate; staminate flowers (4)5-parted; (2) for *U. elata*, stems when greater than or equal to 5 mm diam. hollow, but never fenestrate, small spines present; petiole with small spines; the leaf margins serrate, serrate-dentate, or dentate; staminate flowers 4-parted; (3) for *U. fenestrata*, stems when greater than or equal to 5 mm diam. hollow, fenestrate with prominent ca. 5 mm windows, lacking spines; petioles lacking small spines; the leaf margins entire or weakly crenate to serrate; staminate flowers 4-parted.

Both authors have observed ants of the genera *Crematogaster* Lund. and *Pheidole* Westwood (Formicidae, Myrmicinae) occupying the hollow stems of this species in the field. Collections of these ant species are available at the Instituto Nacional de Biodiversidad entomology collections.

Paratypes. COSTA RICA. **Alajuela:** La Palma de San Ramón, *A. M. Brenes* 136 (5544) (CR, F, NY); La Palma de San Ramón, *A. M. Brenes* 220 (4208) (CR, F); rd. to Finca Los Ensayos off hwy. 15, ca. 7.5 mi. N of Zarcero, *T. B. Croat* 43488 (MEXU, MO); Cordillera de Talamanca, *V. J. Dryer* 44 (CR); Cordillera de Tilarán, *V. J. Dryer* 179 (CR), 233 (CR), 234 (CR); Cantón de San Ramón, Reserva Santa Elena, Cordillera de Tilarán, 100 m NW of Station, *D. Penneys* 19 (INB); Vara Blanca de Sarapiquí, N slope of Central Cordillera, betw. Poás & Barba volcanoes, *A. F. Skutch* 3602 (NY); Cordillera Central near San Juan de Laja, ca. 15 km N of Zarcero, *L. O. Williams*, *A. Molina R.*, *T. P. Williams* & *D. N. Gibson* 28972 (F, NY); Reserva Forestal de Grecia, cuenca superior del Río Rosales, *G. Herrera C.*, *G. Umaño* & *H. Gómez* 542 (BM, INB, MO); above Quaker settlement at Monteverde, *J. Utley* & *K. Utley* 2352 (MO). **Cartago:** Cantón de Paraíso, Reserva Forestal Río Macho, Río Pejivalle, *E. Alfaro* 1799 (INB); Tapantí Hydroelectric Reserve along Río Grande de Orosí, *T. Croat* 36151 (CR); Orosí, farhweg von Río Macho, in westlicher Richtung zum Stausee, *P. Döbbele* 5162 (CR); Tapanti I.C.E. Reservation,

9 mi. from bridge over Río Grande de Orosí, *A. Gentry* 2043 (MO); a la vera del Río Turrialba, camino entre Pacayas y Santa Cruz de Turrialba, *J. Gómez-L.* 8078 (CR); Tausito, S of Tres Ríos, cerros de la Carpintera, *R. Khan*, *M. Tebbs* & *A. R. Vickery* 1318 (BM); ca. S of Tapantí, along Río Grande de Orosí, *R. W. Lent* 806 (CR); Tausito, *R. W. Lent* 3803 (F, NY); Parque Nacional Tapantí, Sector Dos Amigos, *G. Mora* 543 (INB); Reserva Forestal Río Macho, Sector El Embalse, *G. Mora* 643 (INB); Reserva Forestal Río Macho, sendero atrás da casa a direito, *V. Nilsson* & *R. Manfredi* 393 (CR); El Empalme, Interamericana Sur, *L. J. Poveda* 306 (CR); El Guarco, Parque Nac. Tapantí–Macizo de la Muerte, Cerro de la Muerte, 600 m N de Chespirito, *D. Solano* 77 (INB); Turrialba, camino a Moravia, antes del Río Pacuare, *L. O. Williams* & *J. J. Córdoba* 4668 (CR); **Guanacaste:** Palmira, fog zone, *A. Smith* 100 (F, NY). **Heredia:** Parque Nac. Braulio Carrillo, Zurquí station, just above Los Guarumos trail, *B. Boyle* 2450 (BM, CR); Parque Nac. Braulio Carrillo, sector Zurquí, *I. A. Chacón* 1881 (CR); La Palma, Río Bajo de Honduras, Braulio Carrillo Natl. Park, *N. Garwood*, *M. Gibby*, *R. J. Hampshire* & *C. J. Humphries* 386 (BM, CR); Quebrada el Mochote, borde de Cerro Zurquí, *L. D. Gómez*, *I. A. Chacón*, *G. Herrera*, *M. M. Chavarría* 21040 (CR); Porrosatí de Barva, *A. Jiménez* & *R. Rodríguez* 323 (CR); Cantón de Heredia, Cordillera Central, headwaters of Río Santo Domingo, N slope of Volcán Barva, *M. Grayum* 7237 (INB); S slope of Volcán Barva, *W. H. Hatheway* 1354 (CR); Parque Nac. Braulio Carrillo, Estación Barva, *G. Rivera* 258 (INB), *G. Rivera* 259 (INB); Río Porrosatí, 50 m N de parada de buses de Paso Llano, *G. Rivera* 432 (INB); S slopes of Volcán Barba betw. Río Cirueles & Sacramento, *J. Utley* & *K. Utley* 2319 (NY); Parque Nac. Braulio Carrillo, sendero hacia Quebrada Zrquí, *Zamora* 625 (CR). **Limón:** Cantón de Talamanca, Cordillera Talamanca, camp Río Lori, *J. Bittner* 1882 (INB), 1894 (INB). **Puntarenas:** Cantón de Buenos Aires, Estación Tres Colinas, finca Benito Acuña, *E. Alfaro* 745 (INB); Cantón de Coto Brus, Zona Protectora Las Tablas, Las Tablas, sendero Echandi, *E. Alfaro* 1260 (INB); Cantón de Coto Brus, Zona Protectora Las Tablas, I Camp. ACLA, camino a Cerro echando, *E. Alfaro* 1569 (CR); near the Continental Divide ca. 2–5 km E & SE of Monteverde, *W. C. Burger* & *J. L. Gentry* 8639 (CR), 8752 (CR). **Puntarenas–Alajuela border:** 2–5 km E & SE of Monteverde, *W. C. Burger* & *R. L. Liesner* 8639 (F); Reserva Santa Elena, Monteverde, *D. S. Penneys* 19 (CR). **San José:** Vásquez de Coronado, Parque Nac. Braulio Carrillo, sendero frente a Estación Zurquí, *L. Acosta* 480 (CR, INB), *L. Acosta* 486 (CR, INB); valley of Río Hondura (below La Palma), NE of San Jerónimo, *W. C. Burger* & *R. G. Stolze* 4912 (CR, F); Río Claro valley (Río La Hondura drainage), below La Palma, NE of San Jerónimo, *W. C. Burger* & *R. G. Stolze* 7646 (F); bosquecillos residuales entre las Nubes y Cascajal de Coronado, *J. Gómez-Laurito* 5535 (CR); near quebrada Bajo Máquina, 3 km NE of Cascajal, *R. W. Lent* 2500 (BM); Acosta Palmichal, Zona Protectora Cerros de Escazú, El Cedral, ca. de la casa, *S. Lobo* 661 (CR); Cantón de Aserrí, Zona Protectora Cerros de Escazú, Cerros Escazú–La Carpintera, la cima del Cerro Daser, Alto Hierba Buena, *J. F. Morales* & *L. Bohs* 3787 (INB); Cerro Cedral, falda NW, *J. F. Morales* 5866 (CR, INB); Tarrazú, San Carlos, Bajos de La Virgen, confluencia ríos Negro y Blanco, Albergue Ríos Paraíso, *A. Quesada* 1161 (CR); Turrubares, San Luis, San Rafael, Finca de Melvin Chavarría, *A. Rodríguez* 9313 (INB); Alto de la Palma, ca. de 6 km N of San Jerónimo, *J. Utley* & *K. Utley* 635 (CR). **PANAMA. Bocas del Toro:** Chiriquí trail betw. quebrada Higuierón & Gutierrez, *J. H. Kirkbride* & *J. A. Duke* 770 (NY); Caribbean slopes of Cerro Fábrega at foot of “Falso

Fábrega," A. K. Monro & S. Cafferty 4855 (BM, INB, MO, PMA), 4856 (BM, INB, MO, PMA). **Chiriquí:** vic. of Gualaca ca. 10.7 mi. from Planes de Hornito, La Fortuna rd. to dam site, T. Antonio 5111 (BM); betw. Bambito & Cerro Punta, T. B. Croat 10593 (MO); betw. Palo Alto & top of ridge (divide) near Cerro Pate Macho above Río Palo Alto, W. D'Arcy et al. 12658 (BM); Boquete, Bajo Chorro, M. E. Davidson 349 (F); near Fortuna Dam, R. J. Hampshire & C. Whitefoord 214 (BM), 203 (BM); lower reaches of trail to Cerro Pando, A. K. Monro, S. Knapp, J. Mallet, A. Mallet, I. Mallet & V. Mallet 3520 (BM, MO); quebrada Velo, R. E. Woodson & R. W. Schery 257 (MO); vic. of Bajo Mona & quebrada Chiquero, R. E. Woodson & R. W. Schery 593 (GH, MO); Bajo Mona, mouth of quebrada Chiquero, along Río Caldera, R. E. Woodson, P. H. Allen & R. J. Seibert 1005 (MO, NY).

4. **Urera glabriuscula** V. W. Steinm., Acta Bot. Mex. 71: 22. 2005. TYPE: Mexico. Veracruz: Mpio. San Andrés Tuxtla, Volcán San Martín, 1300 m, 2 Apr. 1985, Cedillo T. 3175 (holotype, IEB!; isotype, MEXU not seen).

Local names. K'anäl zulzimtez (Mexico: A. Méndez G. 9054, BM).

Habitat and distribution. Montane forest, deciduous and evergreen forest, *Liquidambar–Taxodium* Rich. forest from 100–2800 m. El Salvador, Mexico (Chiapas, Oaxaca, Tabasco, Veracruz), Guatemala.

Comments. *Urera glabriuscula* is most similar to *U. lianoides* in its glabrous or sparsely pubescent leaves that are entire or discretely divided. The two species can be distinguished from each other based on habit, stem, stipule, staminate flower, and achene morphology as follows: (1) for *U. glabriuscula*, shrub or small tree, leaf-bearing section of stem never hollow, with internodes less than 20 mm; stipule apex minutely forked; pistillode 0.75 mm diam.; achene surface verrucate; (2) for *U. lianoides*, vine or scrambling shrub, leaf-bearing section of stem hollow at ca. 5–10 mm diam. with internodes greater than 20 mm; stipule apex not forked; pistillode 0.375 mm diam.; achene surface smooth.

Selected specimens examined. GUATEMALA. **Quezaltenango:** J. A. Steyermark 34292 (F). MEXICO. **Chiapas:** Mpio. Maragritas, Tenejapa, Colonia Maravilla, A. Méndez G. 9054 (BM, MEXU). **Oaxaca:** Héctor M. Hernández y A. Chacón 487 (MO). **Tabasco:** Mpio. Teapa, en Cerro Madrigal a 500 m al E de Puyacatengo, Universidad Autónoma Chapingo, E. M. Martínez S., J. Calónico Soto, A. M. Hanan-Alipi, M. A. Hernández, A. Martínez & N. Peregrino 34699 (BM, MEXU). **Veracruz:** A. Gentry, E. Lott & UNAM tropical botany class 32227 (BM, MO).

5. **Urera guanacastensis** A. K. Monro & Al. Rodr., sp. nov. TYPE: Costa Rica. Guanacaste: Parque Nacional Guanacaste, Cantón de Liberia, Estación Cacao, 10°55'45"N, 85°28'15"W, 1100 m,

3 June 1990, R. Delgado 24 (holotype, INB!; isotype, MO!). Figure 1F–I.

Species nova *Urerae simplici* Wedd. similis, sed ab ea ramulis glabris, foliis angustioribus supra parce pubescentibus vel galbris subtus domatiis praeditis, pedicellis florum staminatorum brevioribus atque fructu rubro differt.

Shrub to small tree, dioecious (?), main stems arching, 2–4 m, not releasing white latex, without spines; young shoots glabrous; internodes of leaf-bearing sections of stem 3–10 × ca. 2 mm, pale grey-brown, not hollow, lacking a dark stain on the cut portion of the stem. Stipules 5–12 mm, narrowly lanceolate, forked, sparsely pubescent; petioles 6–90 × ca. 0.5 mm, glabrous to sparsely pubescent toward leaf base, the hairs 0.25–0.375 mm, strongly appressed, straight; leaf blade 55–230 × 8–55 mm, narrowly lanceolate, lanceolate to oblanceolate, chartaceous to subcoriaceous; adaxial surface sparsely pubescent to glabrous, the hairs most frequent toward the leaf base, hairs 0.375–0.5 mm, weakly appressed, straight; the cystoliths punctiform, inflated, densely scattered; abaxial surface glabrous; the cystoliths punctiform to oblong, occasionally appearing inflated, scattered and parallel to the veins; primary veins 3, primary to tertiary and occasionally quarternary veins visible to the naked eye, the lateral primary veins finer than midrib and visible for 1/3 of leaf length; domatia present in the axils of the secondary veins, composed of hairs; base obtuse; margins asymmetrically discretely crenate to serrate; apex pungent to subacuminate. Peduncular bracts 1–2 mm; bracteoles 0.25–0.5 mm, staminate inflorescences ca. 15 per stem, peduncle unbranched from base for 6–9 mm, pubescent, the hairs to 0.25 mm, the whole inflorescence 5–40 mm, bearing ca. 110 flowers in a weakly asymmetrical to symmetrical cyme with 4 or 5 orders of dichotomous branching; the flowers subsessile, borne in clusters of 5 to 7; pistillate inflorescences 2 to 21 per stem (4 to 7 in fruit), the peduncle branched to base or unbranched at base for 2–12 mm (6–17 mm in fruit), sparsely pubescent, the hairs ca. 0.1 mm, erect, straight; the whole inflorescence 5–40 mm (23–30 mm in fruit), longer than broad (or as long as broad), bearing 30 to 250 flowers (59 to 67 in fruit) in a symmetrical cyme with 4 or 5 orders of dichotomous branching, flowers pedicellate, borne in clusters of 3, rarely 2 to 4, the pedicels subsessile to 0.25 × 0.175 mm, glabrous. Staminate flowers 1–1.25 × 1.50–1.75 mm immediately prior to anthesis; tepals 4, ca. 2 mm; stamens and pistillode not seen. Pistillate flowers 0.4–0.6 × 0.25–0.6 mm, lateral tepals ca. 0.4 × 0.25 mm, ovate; dorsal tepal ca. 0.4 × 0.25 mm, ovate, the ventral tepal ca. 0.4 × 0.25 mm, ovate; stigma penicillate, erect. Fruit prior

to inflation of tepals with achene entirely obscured by tepals, the laterals ca. 1.75 mm, the dorsal ca. 1 mm, the ventral ca. 0.675 mm, achene 1–1.375 × 0.75–1.25 mm, elliptic, surface smooth, fruit when ripe with tepals inflated and berry-like, 1–1.25 × ca. 2 mm, red.

Habitat and distribution. *Urera guanacastensis* is found in montane and cloud forest, disturbed and undisturbed forest, at 820–1350 m, known only from the Cordillera de Guanacaste in the Cantón de Liberia, Guanacaste Conservation Area in Costa Rica.

IUCN Red List category. Conservation for *Urera guanacastensis* is considered as Near Threatened (NT) according to IUCN Red List criteria (IUCN, 2001). This is based on an evaluation of the potential distribution of *U. guanacastensis*, the threat to its habitat within that area, and the number of existing records for the species. Extrapolating from the 12 collection localities of *U. guanacastensis* plotted on Google Earth, this species' potential distribution covers an area of ca. 680 km². All 12 records are from forest localities (Google Earth, 2008; collection label data) that form part of Costa Rica's protected areas' network. Currently, ca. 50% of the potential distribution is deforested (Google Earth, 2008) and no records exist from deforested localities. We therefore assume that ca. 50% of the original population has been lost and that the future of this species is dependent on the maintenance of Costa Rica's Protected Areas Network.

Etymology. *Urera guanacastensis* is named after the Guanacaste Conservation Area, where all known records of this species have been collected.

Discussion. *Urera guanacastensis* is characterized by narrowly lanceolate, lanceolate, or oblanceolate, glabrous to sparsely pubescent leaves that frequently possess domatia on the abaxial surface composed of a cluster of hairs in the axils of the secondary veins, and by the red color of the mature fleshy fruits (not unique within the genus). It is most likely to be confused with *U. simplex* Wedd., from which it may be distinguished by leaf width, pubescence, and the presence of domatia, as well as by the length of the staminate pedicels and color of the fruit as follows: (1) for *U. guanacastensis*, young stems glabrous; leaves 8–38 mm wide, adaxial surface very sparsely pubescent to glabrous, abaxial surface with domatia in the axils of the secondary veins; pedicels of staminate flowers less than 0.5 mm; mature, fleshy fruit red; (2) for *U. simplex*, young stems pubescent, frequently densely so; leaves 37–210 mm wide, adaxial surface pubescent, frequently densely so, abaxial surface lacking

domatia; pedicels of staminate flowers greater than 1 mm; mature, fleshy fruit orange.

Paratypes. COSTA RICA. **Guanacaste:** Cantón de Liberia, Parque Nac. Guanacaste, Cordillera de Guanacaste, Estación Cacao, sendero Maritza, *L. Angulo 88* (INB); Estación Cacao, bosques primarios y orillas de bosque, *W. E. Bello 2237* (INB); Estación Cacao, *C. Chávez 95* (INB); Parque Nac. Rincón de La Vieja, Cordillera de Guanacaste, Estación Las Pailas, *R. Espinoza 771* (INB); Estación Cacao, sendero a casa de Fran, *B. Gamboa 45* (CR, INB); Estación Mengo, Volcán Cacao, sendero entre Estación y potrero Los Naranjos, *W. B. Hammel & E. Chavarría 17536* (BM); Estación Mengo, sendero el Potrero, lado sur, *II INBio 183* (BM, INB); Estación Cacao, cerro Cacao, sendero a Casa Fran, *W. A. Mora 37* (INB); Estación Cacao, cerro Cacao, *M. Moraga 60* (INB); Estación Cacao, Cerro Cacao, *W. F. Quesada 275* (INB); Sector Las Pailas, Río Colorado, Aguas Arriba, *G. Rivera 651* (INB); Cordillera de Guanacaste, sendero a laguna Santa María, *W. G. Rivera 1152* (INB).

6. *Urera killipiana* Standl. & Steyerl., Fieldiana, Bot. 24: 427. 1952. TYPE: Guatemala. Quetzaltenango: Volcán Junil, 1700 m, 8 Aug. 1934, *A. F. Skutch 982* (holotype, F!; isotype, GH!).

Local names. Chichicaste (Guatemala: *P. C. Standley 76980*, F), chichicaste común (Guatemala: *P. C. Standley 64714*, F), nigüita (Guatemala: *P. C. Standley 75549*, F).

Habitat and distribution. Disturbed vegetation, montane forest, riversides, from 900–3000 m, Mexico (Hidalgo, Queretaro, Oaxaca, Tabasco, Chiapas), Guatemala, and El Salvador.

Comments. *Urera killipiana* is most frequently determined as *U. eggersii* (– *U. simplex*) or *U. caracasana*. These species can be distinguished from each other based on venation, stipule morphology, and stem indumentum as follows: (1) for *U. killipiana*, young stems sparsely pubescent, stipule apex forked or not forked, the secondary veins of the abaxial leaf surface without domatia in their axils, tertiary venation of abaxial leaf surface noticeably paler than the lamina; (2) for *U. caracasana*, young stems densely pubescent, stipule apex not forked; the secondary veins of the abaxial leaf surface frequently with domatia (flap-like or tufts of hairs) in their axils, tertiary venation of abaxial leaf surface darker or of the same color tone as the lamina; (3) for *U. simplex*, young stems densely pubescent, stipule apex not forked; the secondary veins of the abaxial leaf surface without domatia in their axils, tertiary venation of abaxial leaf surface darker or of the same color tone as the lamina.

Selected specimens examined. EL SALVADOR. **San Salvador:** *S. Calderon 727* (GH, NY). GUATEMALA. **San Marcos:** San Marcos, Finca Armenia, *Dwyer 15338* (MO). MEXICO. **Chiapas:** Ocozocoautla de Espinosa, *T. B. Croat*

40599 (MO). **Hidalgo:** Puerto Oscuro near Km 328 on hwy. betw. Santa Ana & Chapulhuacán, Jacala Distr., *H. E. Moore* 5049 (BM). **Oaxaca:** *B. Hammel & M. Merello* 15457 (MO). **Queretaro:** 3–4 km al S de La Parada, Mpio. de Jalpan, *B. Servin* 557 (BM). **Tabasco:** *C. L. Gilly & E. Hernandez* X. 320 (GH, MEXU).

7. *Urera laciniata* Goudot. ex Wedd., *Ann. Sci. Nat., Bot.*, sér. 4, 18: 203. 1854. TYPE: [Colombia] Nouvelle Grenade. "Quindui" [Quindío?], La Bolsa, 1844, *J. Goudot s.n.* (lectotype, designated by de Rooij [1975: 308], P #00281783!).

Urtica girardinoides Seem., *Bot. Voy. Herald* 194. 1854. TYPE: Panama. 1846–1849, *B. Seemann* 494 (lectotype, designated by de Rooij [1975: 308], BM!).

Both epithets, *Urera laciniata* and *Urtica girardinoides*, were published in 1854. According to Stafleu and Cowan (1988: 139), the probable month of publication for Weddell's publication is March, while that for Seemann's publication is July (Stafleu & Cowan, 1985: 476), thereby giving priority to *Urera laciniata*.

Local name. Pringamoza (Panama: *J. A. Duke* 9266, MO).

Habitat and distribution. *Urera laciniata* has been collected from riverside scrub and from sea level to 1200 m. Its range extends from Honduras, Nicaragua, Costa Rica, Panama, Colombia, and Peru to Bolivia.

Comments. The deeply lobed lacinate leaves and large (2–2.5 mm) asymmetrical fruit are unique amongst Mesoamerican *Urera*, and this species is unlikely to be confused with any other.

Selected specimens examined. BOLIVIA. **La Paz:** Franz tamayo, Parque Nac. Madidi, senda Azariamas–San Fermin sector Mutún, E Ticona, *A. Araujo M., V. Torrez, C. Perez, G. Jove & A. Urbano* 149 (BM, MO). COSTA RICA. **San José:** *A. F. Skutch* 4266 (GH, MO, NY). HONDURAS. **Gracias a Dios:** *J. Saunders* 1204 (NY). NICARAGUA. **Jinotega:** Caño Litutus, Río Bocay, *W. D. Stevens, J. H. Beach, J. Schal & O. M. Montiel* J. 16650 (BM, MO). PANAMA. s. loc.: 1846–1849, *B. C. Seemann* 494 (BM). PERU. **Junin:** Cataract El Tirol, *A. K. Monro, R. T. Pennington & A. Daza* 3993 (BM, MOL).

8. *Urera lianoides* A. K. Monro & Al. Rodr., sp. nov. TYPE: Costa Rica. Alajuela: San Miguel Oeste, Naranjo, subiendo por ladera sur del Cerro Espíritu Santo hasta bosque residual en el flanco noreste del mismo, 10°05'20"N, 84°24'20"W, 1000–1200 m, 24 Nov. 1988, *G. Herrera* 2326 (holotype, INB!; isotypes, BM!, MO!). Figure 2A–F.

Species nova *Urerae glabriusculae* V. W. Steinm. similis, sed ab ea habitu lianiformi, parte foliifera caulis 5–10 mm in

diametro cava, stipulis apice integris non furcatis, pistillodio minore atque achenio laevi differt.

Vine, scrambling shrub, dioecious (?); main stems cane-like, to 25 m, young shoots pubescent to densely pubescent, the hairs 0.25–1 mm, erect or weakly appressed, weakly curved or crooked, occasionally straight; internodes of leaf-bearing sections of stem 21–84 × 3.5–10 mm, red-brown, occasionally yellow-green, hollow where 5–10 mm diam., lacking a dark stain on the cut portion of the stem. Stipules 4–12 mm, narrowly ovate or lanceolate, not forked, sparsely pubescent to pubescent; petioles 11–90 (–170) × 0.75–1.5 mm, sparsely pubescent to pubescent, the hairs 0.125–1 mm, appressed, occasionally erect, curved, occasionally crooked or straight; leaf blade 72–280 × 29–110 mm, narrowly ovate, obovate, elliptic, or oblanceolate, always longer than wide, chartaceous and occasionally bullate; adaxial surface sparsely pubescent, the hairs 0.5–0.75 mm, appressed, weakly curved or crooked; the cystoliths punctiform, oblong or occasionally fusiform, occasionally inflated, randomly scattered and occasionally parallel to veins, rarely arranged radially around a hair base; abaxial surface pubescent, the hairs 0.125–0.5(1) mm, appressed or erect, weakly curved, occasionally straight; the cystoliths fusiform, occasionally oblong, parallel to the veins, occasionally randomly scattered; primary veins 3, occasionally 5, primary to quaternary veins visible to the naked eye, the lateral primary veins visible for 1/2–2/3 of the leaf length; domatia not present in the axils of the secondary veins; base subcordate or obtuse, occasionally cuneate; margins dentate, occasionally crenate-dentate or nearly entire; apex cuspidate. Peduncular bracts 1.25–2 mm; bracteoles 0.25–0.5 mm. Staminate inflorescences 1 to 12 per stem, peduncle branched to the base or unbranched from the base for 4.5–9 mm, densely pubescent, the hairs to 0.25 mm, the whole inflorescence 19–56 mm, bearing 192 to 384 flowers in an asymmetrical cyme with 4 or 5 orders of dichotomous branching; flowers borne in clusters of 6 to 12, sessile; pistillate inflorescences ca. 6 per stem, unbranched base of peduncle 7–13 mm, 5–11 mm in fruit, densely pubescent, the hairs 0.125–0.25 mm, erect, straight; the whole inflorescence 12–40 mm (12–45 mm in fruit), broader than long, bearing 112 to 448 flowers in an asymmetrical cyme, with 4 to 6 orders of dichotomous branching; the flowers borne in clusters of 3, pedicellate, the pedicels 0.5–0.675 × 0.125–0.25 mm, glabrous. Staminate flowers ca. 1.25 × 1.25 mm immediately prior to anthesis; tepals 4, 1–1.5 mm; stamens ca. 1.75 mm; pistillode ca. 0.375 mm diam., glabrous. Pistillate flowers 0.5–1 × 0.375–0.5 mm, white to yellow-green; lateral tepals 0.375–0.75 mm, asym-

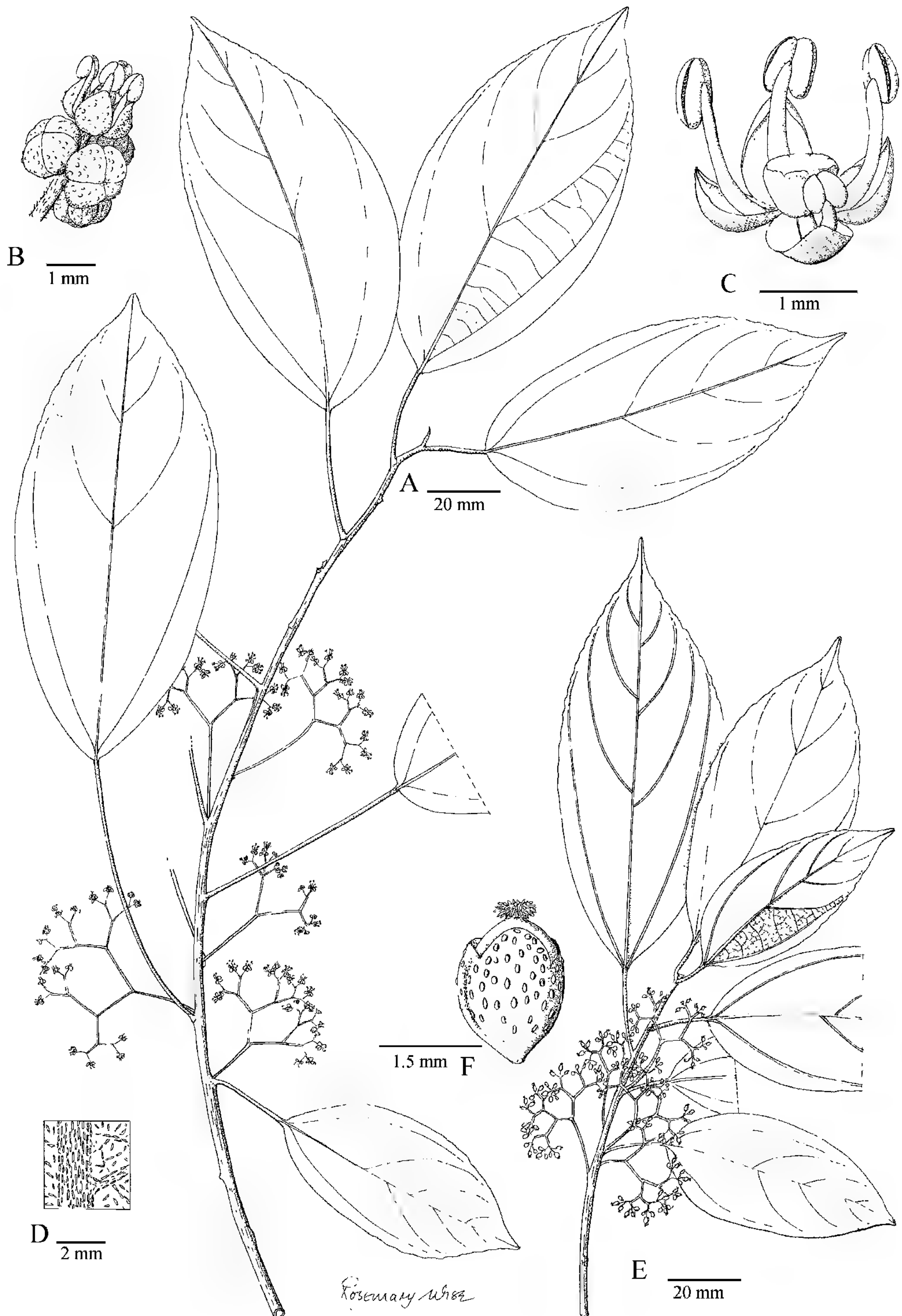

Figure 2. *Urera lianoides* A. K. Monro & Al. Rodr. —A. Habit with staminate inflorescences. —B. Cluster of staminate flowers. —C. Staminate flower at anthesis. —D. Leaf abaxial surface with cystoliths. —E. Habit, with pistillate inflorescences. —F. Immature fruit. (A–D: Johnson 1600 [GH]; E, F: Shank & Molina R. 4405 [NY]).

metrically ovate, dorsal tepal 0.25–0.75 mm, ovate, with a subapical dorsal thickening; ventral tepal 0.25–0.75 mm, ovate, stigma penicillate. Fruit prior to inflation of tepals ca. 1.5×0.75 mm; basal 3/4 of achene obscured by tepals, lateral tepals ca. 1 mm, dorsal tepals ca. 0.75 mm, ventral tepals ca. 0.5 mm; achene $1.25\text{--}1.5 \times 1\text{--}1.25$ mm, asymmetrically elliptic, keel-shaped, surface smooth. Fruit when ripe, with tepals inflated and berry-like $1.5\text{--}2.25 \times 1.25\text{--}1.75$ mm, orange when fresh.

Habitat and distribution. The new species is found in premontane, montane, and cloud forest, in disturbed and undisturbed forest, from sea level to 1300(1900–2500) m. Mexico (Chiapas), Guatemala, Honduras, Nicaragua, Costa Rica, Panama, Peru, and Bolivia.

IUCN Red List category. Conservation for *Urera lianoides* must be considered as Least Concern (LC) according to IUCN Red List criteria (IUCN, 2001), owing to the fact that the species has been collected 50 times in several localities across Central and South America.

Etymology. From the English “liana” or “vine,” derived from the French, “lier,” which, in turn, is derived from the Latin “ligare” or “to tie,” referring to the liana-like habit of this species.

Discussion. *Urera lianoides* is distinguished by its scandent habit, hollow stems, sparse non-urticating hairs, and orange, mature, fleshy fruit. Material of *U. lianoides* from Chiapas differs from other collections of this species in having densely pubescent young stem and abaxial leaf surfaces, with very short hairs (0.5 mm or less). This species corresponds to “sp. A” in the treatment of *Urera* in the *Flora de Nicaragua* (Pool, 2001: 2495). *Urera lianoides* most closely resembles *U. glabriuscula* with which it shares a distribution in Chiapas, Mexico. The two species can be distinguished from each other as follows: (1) for *U. lianoides*, a vine or scrambling shrub, ca. 5–10 mm diam., leaf-bearing stem section hollow, with internodes greater than 20 mm; stipule apex not forked; pistillode 0.375 mm diam.; achene surface smooth; (2) for *U. glabriuscula*, a shrub or small tree, ca. 5–10 mm diam., leaf-bearing stem section never hollow, with internodes less than 20 mm; stipule apex minutely forked; pistillode 0.75 mm diam.; achene surface verrucate.

Paratypes. BOLIVIA. **Beni:** Provincia Ballivian, Pilon Laja, 130 km de San Borja, *M. Moraes* 670 (K). **La Paz:** Provincia Nor Yungas, ca. 2 km al S de Coroico, *S. G. Beck* 21926 (K); Santa Fé Tacana, al lado de la parcela permanente de Santa Fé, *G. Bourdy* 1746 (K). **Tarija:** Provincia Arce, 108 km de Tarija hacia Bermejo, *R. Ehrich* 494 (K). COSTA RICA. **Alajuela:** Cantón de San Ramón,

Reserva Biológica Monteverde, Cordillera de Tilarán, Refugio de Eladio, Valle del Río Peñas Blancas, *E. Bello* 5181 (INB); La Palma de San Ramón, *A. M. Brenes* 5793 (F, NY); Mata Cartago, La Palma de San Ramón, *A. M. Brenes* 6308 (F, NY); quebrada Azul (San Carlos), *A. M. Brenes* 23063 (NY); Guatuso, Parque Nac. Volcán Tenorio, El Pilon, colectado en bosque primario a orillas de sendero Los Misterios del Tenorio, *J. L. Chávez* 874 (INB); Cantón de Los Chiles, Refugio Natural de Vida Silvestre Caño Negro, Río Frío, Finca Betel, *K. Flores & M. Flores* 130 (INB); Reserva Biológica Monteverde, Río Peñas Blancas, Finca Wilson Salazar, vertiente Atlántica, *W. Haber & E. Bello* 7403 (INB, MO); Reserva Monteverde, Poco Sol 13 km S Fortuna, *W. Haber & W. Zuchowski* 9377 (BM, INB); Upala, Bijagua, El Pilon, cabecera del Río Celeste, *G. Herrera* 1293 (BM, INB); N side of Volcán Arenal, *R. W. Lent* 2922 (F); Upala, Zona Protectora Miravalles, 3 km W of Bijagua, ridges above Río Zapote, *D. S. Penneys & W. Haber* 710 (INB); Parque Nac. Rincón de La Vieja, Colonia La Libertad, Finca Julio Soto, *G. Rivera* 1485 (INB); Colonia Blanca, Finca Río Negro, *G. Rivera* 1563 (INB); San Carlos, Parque Nac. Arenal, Cerro Chato, sendero que lleva a la Laguna, *A. Rodríguez, V. H. Ramírez, G. de La O & G. Soto* 6254 (INB); Colegio Agropecuario, Santa Clara, Cantón de San Carlos, *A. S. Weston, D. F. Weston & J. Weston* 3104 (MO). **Cartago:** Cantón de Turrialba, Valle del Reventazón, Carolina, Moravia de Chirripó, *P. Campos* 176 (INB); 1/2 km S of Chitaría, near rd. #CR233, *R. W. Lent* 237 (NY). **Guanacaste:** Cantón de Tilarán, Cordillera de Tilarán, 1–2 km W of Lago de Cote, 13 km N of Tilarán, continental divide on SE, slope of Volcán Tenorio, *W. Haber & W. Zuchowski* 11624 (INB). **Heredia:** L. R. Holdridge’s Finca La Selva, Río Puerto Viejo at quebrada El Sura & quebrada El Salto, ca. 1 mi. above jct. Río Sarapiquí, *G. B. Rossbach* 3690 (GH); roadside bank about 35 km NE of Alajuela, *R. J. Taylor* 4536 (NY). **Limón:** Level areas betw. Siquerres & Río Pacuare, steep hills S of the railroad bridge over the Río Pacuare, *W. C. Burger & R. L. Liesner* 6952 (NY); borde de lago Dabagri hasta Río Llei, *L. D. Gómez et al.* 23129 (BM); Costado Oeste de lago Dabagri hasta Río Llei, *L. D. Gómez et al.* 23172 (BM); vecino al puente sobre el Río Toro Amarillo, 5.5 km al SO de Guápiles, *A. Jimenez M.* 1067 (F); pantanosos-yolillosos de Suerre y Dos Bocas, drenajes de los Ríos Parismina y Reventazón, *P. J. Shank & A. Molina R.* 4265 (GH); pantanosos-yolillosos de Goldengrove, drenaje de Río Reventazón, *P. J. Shank & A. Molina R.* 4405 (F). **Puntarenas:** Cantón de Osa, Refugio Forestal Golfo Dulce, Península de Osa, Los Mogos, Bahía Chal, entrada Chocuaco, *R. Aguilar* 3591 (INB); foothills of Cordillera de Talamanca, just N of Santa Elena on Fila Cotón, S of Agua Caliente, *G. Davidse, G. Herrera Ch. & M. H. Grayum* 28277 (BM); Osa, Ballena, entrando por Puertecito, hasta el Cerro Escalera, *J. González & C. Aragón* 2327 (INB); Cantón de Coto Brus, Parque Internacional La Amistad, Cordillera de Talamanca, Estación Pittier, Agua Caliente, *E. Navarro* 211 (INB); cantón de Osa, Península de Osa, Rancho Quemado, *F. Quesada* 167 (INB); deep forest near airport, 4 mi. W of Rincón de Osa, Osa Península, *P. H. Raven* 21623 (MO); Canton de Osa, Refugio Forestal Golfo Dulce, Península de Osa, Rancho Quemado, Fila Guerra, Rincón, finca del Grupo de Conservación, *M. Segura* 4 (INB); Reserva Biológica Monteverde, Cordillera de Tilarán, San Luis de Monteverde, bosques en la cuenca del Río San Luis, *K. Taylor* 118 (INB); Rincón de Osa, area N of airport, *J. Utley & K. Utley* 1173 (F). **San José:** Canton de Pérez Zeledón, Cordillera de Talamanca, Las Nubes, Santa Elena, *E. Alfaro* 329 (INB); W part of montañas Jamaica, ca. 3 km NE of Bijagual de

Turrubares, Carara reserve, *M. H. Grayum et al.* 5878 (BM); Zona Protectora La Cangreja, Mastatal de Puriscal, *J. F. Morales* 727 (INB); Acosta, Colorado, Fila San Jerónimo, Río Colorado, *J. F. Morales* 7383 (INB); Acosta, Aserri, Agua Buena, cabeceras Quebrada Laja, *J. F. Morales et al.* 9937 (INB); vic. of El General, *A. F. Skutch* 2863 (GH, MO, NY). GUATEMALA. **Petén:** Dolores, ca. 100 m del cementario, lado N, *R. Tún O.* 1323 (BM, F). **Suchitepequez:** Finca Mocá, *A. F. Skutch* 1479 (GH). HONDURAS. **Atlantida:** Vic. of La Ceiba, bank of Danto river, slopes of Mount Cangrejal, *T. G. Yuncker, J. M. Koeppe & K. A. Wagner* 8454 (GH, MO, NY). **Cortés:** Aldea de Corinto y alrededores frontera con Guatemala, 55 km al O de Puerto Cortés, *C. Nelson, E. Vargas, M. Erazo, M. García & M. Sierra* 2926A (BM, MO). **Olancho:** Vaguada del Río de la población de Culmí, *C. Nelson & E. Romero* 4738 (MO). MEXICO. **Chiapas:** 2–4 km below Ixhuatán along rd. to Pichucalco, Muni. of Solosuchiapa, *D. E. Breedlove* 19906 (MO); long gravel rd. betw. Palenque & Bonampak, 60 mi. SE of Palenque, *T. B. Croat* 40192 (MEXU, MO); along gravel rd. betw. Palenque & Bonampak, 88–90 mi. SE of Palenque, *T. B. Croat* 40230 (MO); along hwy. 195, betw. Chiapa de Corzo & Pichucalco, ca. 6 mi. NW of Pueblo Nuevo Solistahuacán, along mirador overlooking Caribbean slope, Selva Negra lookout point at trail to Colonia Pinabeto, vic. Km 99, *T. B. Croat & D. P. Hannon* 65180 (MO); Crucero Corozal, camino Palenque–Boca Lacantum, Mpio. Ocozingo, *E. Martínez S.* 15439 (BM); a 14 km al NW de Crucero Corozal sobre el camino Palenque–Boca Lacantum, Mpio. Ocozingo, *E. Martínez S.* 16642 (BM). **Veracruz:** camino Bastonal–Tebanca, Mpio. Catemaco, *R. Cedillo T.* 3439 (BM); Estación Biológica Los Tuxtlas, *B. Hammel, M. Merello & S. Sinaca* 15492 (MO). NICARAGUA. **Chontales:** On ridge top of Cordillera Amerisque, *A. Gentry, W. D. Stevens, A. Grijalva P. & P. P. Moreno* 43950 (MO). **Granada:** Volcán Mombacho, Hacienda UPE–Pancasán (antes del cráter), *A. Grijalva, O. Vanegas & R. M. Rueda* 2924 (BM); NE del Volcán Mombacho, en el emplame de los caminos a Sta. Isabel y a Cutirre, *P. Moreno* 2602 (BM, MO); Volcán Mombacho, subiendo por la Finca Las Delicias, 1.5 km de la hacienda, *P. P. Moreno* 4103 (MO); NW slopes of Volcán Mombacho, 10 km S of Granada, *M. Nee & J. Miller* 27693 (MO); NW de Volcán Mombacho, cafetales de Finca Cutirre y camino que lleva S del volcán, *J. C. Sandino* 1273 (BM, MO). **Zelaya [Región Autónoma del Atlántico Sur]:** along the rd. betw. Nueva Guinea & Verdún, *J. S. Miller & J. C. Sandino* 1094 (MO); Monkey Point, Caño el Pato, 1.5 km sobre la ribera del Caño, *P. P. Moreno* 12397 (MO). PANAMA. s. loc.: *S. Hayes* 683 (K); Canal area, vic. of Madden Dam, *P. H. Allen* 2008 (F, NY); Barro Colorado Island, *S. Aviles* 106 (F); rd. S-11, NW of Escobal, *T. B. Croat* 12466 (BM, NY); rd. along Río Piña–Río Media divide, NW part of Canal Zone (area W of Limon Bay, Gatun Locks & Gatun Lake), *I. M. Johnston* 1600 (GH); rd. along W side of Gatun lake, NW part of Canal Zone (area W of Limón Bay, Gatun Locks & Gatun Lake), *I. M. Johnston* 1706 (GH); 12 mi. S of Colón, *E. L. Tyson et al.* 4478 (GH). **Bocas del Toro:** Ridge N of Campamento Luchio, *A. K. Monro & E. Alfaro* 4506 (BM, INB, MEXU, MO, PMA); Río Cricamola, betw. Finca St. Louis & Konkintoë, *R. E. Woodson, P. H. Allen & R. J. Seibert* 1923 (GH, NY); 10–15 mi. inland S from mouth of Changuinola River, *W. H. Lewis, J. D. Dwyer, T. S. Elias & K. R. Robertson* 867 (GH, K, UC, US). **Chiriquí:** Bajo Chorro, Boquete Distr., *M. E. Davidson* 349 (MO). **Coclé:** Foothills of Cerro Pilón, near El Valle, *J. Duke & M. Correa* 14670(1) (MO); El Valle from potato farm above village to Cerro Pilon, *J. Dwyer & M. Correa* 7923 (BM). **Colón:** From

Portobelo hwy. to 4 km up Río Guanche, *S. Knapp* 1016 (BM); Río Guache, *K. J. Sytsma* 1617 (BM). **Darién:** Parque Nac. Darién, Serranía de Sapo, límite del Parque hasta la cima, *H. Herrera & J. Polanco* 795 (BM). **Panamá:** Piriati, S of Pan-American Hwy., *C. Hamilton* 558 (BM). PERU. **Madre de Dios:** Parque Nac. del Manu, Río Manu, Cocha Cashu Station, *J. Terborgh & R. B. Foster* 6488 (K).

9. *Urera simplex* Wedd., Prodr. (DC.) 16(1): 90. 1869. TYPE. Colombia. Cundinamarca: “ad salto de Tequendama,” Mar. 1856, *Triana s.n.* (holotype, P 00281785!).

Urera eggersii Hieron., Bot. Jahrb. Syst. 20: 3. 1895. TYPE: Ecuador. Pichincha: 20 km W of Santo Domingo de los Colorados, 1000 ft., 25 Nov. 1961, *P. C. D. Cazalet & T. D. Pennington* 5150 (neotype, designated here, K!; isotypes, B not seen, NY not seen).

Urera rzedowskii V. W. Steinm., Acta Bot. Mex. 71: 37. 2005. TYPE: Mexico. Veracruz: Mpio. San Andrés Tuxtla, 8 km al N de San Andrés Tuxtla, Laguna Encantada, 18°28'N, 95°10'W, 350 m, 4 Apr. 1981, *J. I. Calzada* 8105 (holotype, IEB not seen; isotype, ENCB not seen).

Urera tuerckheimii Donn. Sm., Bot. Gaz. 23(1): 14. 1897. TYPE: Guatemala. Alta Verapaz: Pansamalá, 1160 m, May 1887, *H. von Tuerckheim* 1243 (holotype, US not seen; isotype, NY!).

A neotype was selected for *Urera eggersii* because the type collection cited by Hieronymus, *Eggers* 14466 (B), was destroyed in enemy action during World War II and only photographs of the holotype could be located (F, MO). The neotype was selected on the basis that it includes good leaf and fertile material and was from the same country as the holotype.

Local names. Bilsimtezla (Mexico: *A. Méndez T.* 6738, BM), chenek'mut (Mexico: *A. Méndez T.* 4863, BM), chichicaste (Guatemala: *P. C. Standley* 68232, F; Mexico: *M. Heath & A. Long* MA 44, BM), chichicaste huevo de cangrejo (El Salvador: *E. Sandoval & H. Rivera* 1252, MO), sakil zulsimtez laa (Mexico: *A. Méndez T.* 6238, BM), tzotzniz zul simtez (*A. Méndez T.* 9066, BM), zulsimtezla (Mexico: *A. Méndez T.* 7022, BM).

Habitat and distribution. Disturbed and undisturbed forest, cloud forest, and humid scrub from sea level to 2500 m. Mexico (Chiapas, Tabasco, Veracruz), Belize, Guatemala, Honduras, El Salvador, Nicaragua, Costa Rica, Panama, Colombia, Ecuador, Peru, Bolivia, Brazil.

Comments. Material of this species has frequently been determined and referred to (*Flora of Guatemala*, *Flora de Nicaragua*, and *Flora Costaricensis*) as *Urera elata*, *U. eggersii*, or *U. tuerckheimii*. Examination of type material of these species indicates that *U. elata* is a species endemic to Jamaica, while *U. eggersii* and *U. tuerckheimii* are conspecific with *U. simplex*. Pool

(2001) indicates *U. tuerckheimii* (– *U. simplex*) may correspond to *U. aurantiaca* Wedd. from South America (Argentina, Bolivia, Paraguay); however, comparison of the holotypes suggests that the two species are distinct, with *U. aurantica* characterized by ovate or cordiform leaves and relatively short pistillate inflorescences and known only from South America (Argentina, Bolivia, Brazil, and Paraguay). Some collections of *U. simplex* from Costa Rica and Panama, e.g., *Kennedy 1939* (GH) and *Folsom y Page 5984* (PMA), are unusual in the possession of narrowly oblanceolate pubescent leaves, while some material from Chiapas (*Purpus 7039*, NY) is characterized by densely pubescent leaves. *Urera simplex* most closely resembles *U. elata*. The two species can be distinguished from each other based on petiole morphology and inflorescence peduncle size as follows: (1) for *U. simplex*, petiole lacking small spines; staminate flowers 5-parted, occasionally 4-parted; (2) for *U. elata*, petiole with small spines; staminate flowers 4-parted.

Selected specimens examined. BELIZE. **Stann Creek:** Middlesex, *W. A. Schipp 400* (BM, F, GH, NY). BOLIVIA. **La Paz:** N Yungas, valle de Huarinillas, Estación Biológica Tunquini, *S. G. Beck 24612* (K, LPB). BRAZIL. **Amazonas:** *E. Ule 5465* (K). COLOMBIA. **Putumayo:** Umbría, *G. Klug 1741* (K). COSTA RICA. **Puntarenas:** Cantón de Golfito Dos Brazos de Río Tigre, Jiménez, orilla de Quebrada Pizote, *G. Cordero 95* (BM, INB, MO). ECUADOR. **Pichincha:** *P. C. D. Cazalet & T. D. Pennington 5073* (K). EL SALVADOR. **Ahuachapán:** Finca L'Esperanza, Jujutla, *A. K. Monro et al. 2997* (BM, ITIC, LAGU, MO). HONDURAS. **Olancho:** Catacamas, Río Catacamas, slope of Sierra de Agalto, *S. Blackmore & G. L. A. Heath 1916* (BM). MEXICO. **Chiapas:** Finca Mexiquito, *C. A. Purpus 7039* (BM, F, MO, NY). NICARAGUA. **Matagalpa:** Macizo de Peñas Blancas, Finca San Sebastian, *O. Téllez V., R. Riviere, W. D. Stevens, O. M. Montiel J., M. Guzmán & D. Castro 5181* (BM, MEXU). PANAMA. **Comarca de San Blas:** Udirbi Reserve, along park boundary, *J. F. McDonagh et al. 257* (BM, MO). PERU. **Huanuco:** Vic. of Tingo María cliffs above Río Monzon, *M. E. Mathias & D. Taylor 5343* (K).

10. *Urera verrucosa* (Liebm.) V. W. Steinm., *Acta Bot. Mex.* 71: 39. 2005. Basionym: *Urtica verrucosa* Liebm., *Kongel. Danske Vidensk. Selsk. Skr., Naturvidensk. Math. Afd., ser. 5, 2:* 295. 1851. *Urera caracasana* var. *tomentosa* (Wedd.) Wedd., *Prodr.* 16: 90. 1869, nom. illeg., superfl. TYPE: Costa Rica. Cartago: Irasú, *Oersted 14284* (holotype, C!).

Local names. Chichicaste (Mexico: *E. Kerber 333*, BM).

Habitat and distribution. Montane forest, shade coffee farms, *Pinus–Quercus–Liquidambar* forest, from 500–2800 m. Mexico (Chiapas, Veracruz), Guate-

mala, Honduras, El Salvador, Costa Rica, Panama, Peru, and Bolivia.

Comments. *Urera verrucosa* most closely resembles *U. caracasana*. The two species can be distinguished from each other based on leaf texture and inflorescence peduncle size as follows: (1) for *U. verrucosa*, leaves bullate; staminate peduncle unbranched at base for 40–80 mm, densely pubescent; pistillate peduncle unbranched at base for 27–98 mm; (2) for *U. caracasana*, leaves chartaceous; staminate peduncle branched to base or unbranched at base for 2–13 mm; pistillate peduncle branched to base or unbranched at base for 2–20 mm.

Selected specimens examined. BOLIVIA. **La Paz:** *M. Lewis 882155* (K). COSTA RICA. **Cartago:** N of Cartago, Río Reventada, *R. Khan, M. Tebbs & A. R. Vickery 959* (BM). EL SALVADOR. **Ahuachapán:** Lago de Ninfas, Cordillera Grande de Apaneca, NW of Juayua, *G. Davidse, K. Sidwell, A. Monro, M. A. Renderos & C. Cortez 37383* (BM, ITIC, LAGU, MO). GUATEMALA. **Chimaltenango:** On hwy. CA1 betw. turnoff to Patzún & Sololá, 14.8 mi. NNW of turnoff to Patzún, 23.5 mi. SSE of turnoff to Sololá, *T. B. Croat & D. P. Hannon 64732* (BM, MO). MEXICO. **Veracruz:** Orizaba, *M. Botteri 288* (BM). PANAMA. **Chiriquí:** 3 km NW of Cerro Punta, along dirt rd. on rte. to Las Nubes, *B. Hammel 1363* (BM, MO, NY). PERU. **San Martín:** *T. D. Pennington & A. Daza 16676* (K, MOL).

Literature Cited

- Badilla, B., G. Mora, A. J. Lapa & J. A. Silva E. 1999. Anti-inflammatory activity of *Urera baccifera* (Urticaceae) in Sprague-Dawley rats. *Revista Biol. Trop.* 47: 365–371.
- Britton, N. L. & P. Wilson. 1924. Botany of Porto Rico and the Virgin Islands. *Sci. Surv. Porto Rico & Virgin Islands* 5: 243.
- Burger, W. 1977. *Urera*. In *Flora Costaricensis*. *Fieldiana, Bot.* 40: 276–280.
- Davidse, G., M. S. Sousa & A. O. Chater. 1994. Introducción general. Pp. xiii–xiv in G. Davidse, M. S. Sousa & A. O. Chater (editors), *Flora Mesoamericana*, Vol. 6, Alismataceae a Cyperaceae. Universidad Nacional Autónoma de México, México D. F.; Missouri Botanical Garden, St. Louis; The Natural History Museum, London.
- de Rooij, M. J. M. 1975. *Urera*. Pp. 301–309 in J. Lanjouw & A. L. Stoffers (editors), *Flora of Suriname*, Vol. 5(1). E. J. Brill, Leiden.
- Field Museum of Natural History. 2006. The Botany Collections Database. Department of Botany, Field Museum of Natural History, Chicago. <<http://emuweb.fieldmuseum.org/botany/Query.php>>, accessed 3 September 2008.
- Friis, I. 1989. The Urticaceae: A systematic review. Pp. 285–308 in P. R. Crane & S. Blackmore (editors), *Evolution, Systematics, and Fossil History of the Hamamelidaceae*, Vol. 2. Systematics Association Special Volume 40B. Oxford Science Publications, Oxford, United Kingdom.
- Gaudichaud-Beaupré, C. 1830. *Urera*. Pp. 496–497 in *Voyage autour du Monde, entrepris par ordre du roi... exécuté sur les corvettes de S.M. l'Uranie et la Physicienne... par M. Louis de Freycinet*. Botanique. Pp. 496–497 Pillet-ainé, Paris.

- González, J. C. 1994. *Botánica Medicinal Popular, Etnobotánica Medicinal de El Salvador*. Jardín Botánico La Laguna, Cuscatlán, El Salvador.
- Google Earth. 2008. <<http://earth.google.com>>, accessed 12 April 2008.
- Guánchez, F. J. 1999. *Plantas amazónicas de uso medicinal y mágico*. Fundación Polar, Servicio Autónomo para el Desarrollo Ambiental del Amazonas, Caracas.
- House, P. R., S. Lagos-Witte, L. Ochoa, C. Torres, T. Mejía & M. Rivas. 1995. *Plantas Medicinales Comunes de Honduras*. Litografía López, S. de R. L. Universidad Nacional Autónoma de Honduras/Comité Internacional de Medicina Natural en Honduras/Cooperación Internacional para el Desarrollo (Programa de Cooperación Técnica Británica en Honduras)/Deutsche Gessellschaft für Technische Zusammenarbeit, Tegucigalpa.
- International Plant Names Index. 2008. <<http://www.ipni.org>>, accessed 19 June 2008.
- IUCN. 2001. *IUCN Red List Categories and Criteria, Version 3.1*. Prepared by the IUCN Species Survival Commission. IUCN, Gland, Switzerland, and Cambridge, United Kingdom.
- Janzen, D. H. & W. Hallwachs. *Caterpillar food plants of the Area de Conservación Guanacaste, northwestern Costa Rica*. <<http://janzen.sas.upenn.edu/Wadults/searchfood.lasso>>, accessed 9 November 2005.
- Linnaeus, C. 1763. *Species Plantarum*, ed. 2. Stockholm.
- Miquel, F. A. W. 1853. *Urera*. Pp. 188–193 in *Flora Brasiliensis* (Martius), Vol. 4(1). Fleischer, Leipzig.
- Monro, A. K. 2006. The revision of species-rich genera: A phylogenetic framework for the strategic revision of *Pilea* (Urticaceae) based on cpDNA, nrDNA, and morphology. *Amer. J. Bot.* 93: 426–441.
- Pool, A. 2001. *Urera*. In W. D. Stevens, C. Ulloa, A. Pool & O. M. Montiel (editors), *Flora de Nicaragua*. Monogr. Syst. Bot. Missouri Bot. Gard. 85: 2492–2495.
- Stafleu, F. A. & R. S. Cowan. 1985. *Taxonomic Literature*, 2nd ed., Vol. 5. Bohn, Scheltema & Holkena, Utrecht/Antwerpen, and Dr. W. Junk b.v. Publishers, The Hague/Boston.
- , ——— & H. A. Weddell. 1983. *Taxonomic Literature*, 2nd ed., Vol. 7. Bohn, Scheltema & Holkena, Utrecht/Antwerpen, and Dr. W. Junk b.v. Publishers, The Hague/Boston.
- Standley, P. C. & J. A. Steyermark. 1952. *Urera*. In *Flora of Guatemala*. Fieldiana, Bot. 3: 424–428.
- Steinmann, V. W. 2005. Four new neotropical species and a new combination of *Urera* (Urticaceae). *Acta Bot. Mex.* 71: 19–43.
- Vellozo, J. M. C. 1827 [1831]. *Florae Fluminensis* 10. Typographia Nationali, Rio de Janeiro.
- Weddell, H. A. 1856. *Urera*. Pp. 143–162 in G. Baudry & J. Baudry (editors), *Monographie de la Famille des Urticacées*. G. and J. Baudry, Paris.
- . 1869. *Urera*. Pp. 199–203 in A. de Candolle (editor), *Prodromus* (DC.), Vol. 16. Paris.
4. *U. glabriuscula* V. W. Steinm.
 5. *U. guanacastensis* A. K. Monro & Al. Rodr.
 6. *U. killipiana* Standl. & Steyermark.
 7. *U. laciniata* Goudot. ex Wedd.
 8. *U. lianoides* A. K. Monro & Al. Rodr.
 9. *U. simplex* Wedd.
 10. *U. verrucosa* (Liebm.) V. W. Steinm.
- Acosta, L.* 480 (3), 486 (3); *Aguilar, I.* 387 (10); *Aguilar, R. et al.* 3591 (8); *Alclos S., J.* 92 (9); *Alcrasquilla, L.* 180 (10); *Alfaro, E.* 329 (8), 745 (3), 1260 (3), 1569 (3); *Allen, P. H.* 911 (cf. 2), 926 (1), 1471 (10), 2008 (8), 3617 (9), 6315 (1), 6325 (9), 6330 (2), 6946 (10), 855 (cf. 2); *Anderson, R. & Mori, S.* 147 (1); *Angulo, L.* 88 (5); *Antonio, T.* 611 (1), 1118 (9), 1738 (9), 3528 (2), 4988 (9), 5111 (3); *Araquistain, M.* 3182 (9); *Araquistain, M. & Castro, D.* 1905 (1); *Araquistain, M. & Moreno, P. P.* 1502 (2), 2009 (1), 2235 (1), 2285 (1), 2358 (9), 2473 (9), 2605 (9), 2790 (9), 2863 (1); *Atwood, J. T. & Moore, A. D.* 304 (2), 489a (1); *Aviles, S.* 32 (9), 106 (8). *Baker, C. F.* 2011 (2); *Baker, R.* R53 (2); *Bangham, W. N.* 211 (9); *Barkley, F. A. & Barkley, E. D.* 40130 (1); *Barkley, F. A. & Hernandez R., J.* 40263 (1); *Barkley, F. A. & Leiva-Welchez, L.* 39579 (2); *Barkley, F. A. & Smith, M. L.* 40859 (9); *Barrelier, M.* 11 (9); *Bello, E.* 2237 (5), 3143 (2), 5181 (8); *Bittner, J.* 1882 (3), 1894 (3); *Blackmore, S. & Heath, G. L. A.* 1916 (9); *Botteri, M.* 288 '854' (10); *Boyle, B.* 2450 (3); *Breedlove, D. E.* 9107 (1), 9994 (4), 10003 (5), 19906 (8), 20207 (9), 23388 (4), 24109 (9), 24249 (4), 24998 (9), 34570 (4), 51467 (5); *Breedlove, D. E. & Raven, P. H.* 13559 (4), 13583 (9); *Breedlove, D. E. & Smith, A. R.* 19905 (9), 21681 (9), 31520 (4); *Breedlove, D. E. & Thorne, R. F.* 30986 (10); *Brenes, A. M.* 136 (5544) (3), 220 (4208) (3), 339 (9), 3480 (9), 3596 (9), 5524 (2), 5793 (8), 6039 (2), 6308 (8), 6764 (9), 23063 (8); *Brown, E.* 6 (2); *Bunting, G. S. & Licht, L.* 1137 (1); *Burch, D.* 4603 (9); *Burger, W. C.* 4161 (1); *Burger, W. C. & Antonio, T.* 10956 (9), 10993 (1); *Burger, W. C. & Baker, R.* 10013 (1); *Burger, W. C. & Burger, M.* 7678 (9), 8496 (9); *Burger, W. C. & Gentry, J. L.* 8639 (3), 8752 (3), 8836 (9), 8984 (9), 9092 (7); *Burger, W. C. & Liesner, R. L.* 6605 (2), 6879 (1), 6952 (8); *Burger, W. C. & Matta U., G.* 4819 (9); *Burger, W. C. & Stolze, R. G.* 4912 (3), 5608 (9), 5904 (2); *Burger, W. C. et al.* 10502 (1), 10563 (1). *Cabrera, E. et al.* 2666 (4); *Cafferty, S. & Monro, A. K.* 16 (9); *Calderón, S.* 727 (5), 850 (2), 1510 (2), 1539 (1), 1687 (2), 1775 (2), 1809 (2); *Calónico S., J. et al.* 21101 (4), 21242 (4); *Campos, P.* (8); *Carlson, M. C.* 391 (10), 2056 (1); *Chacón, I. A.* 1881 (3); *Chavarria, U.* 303 (2); *Chavelas, P. et al.* ES-2280 (9); *Chávez, C.* 95 (5); *Chávez, J. L.* 874 (8); *Chickering, A. M.* 126 (9); *Chorley, M. & R. Atkinson* 88 (2); *Christopherson, E. D.* 178 (10); *Chrysler, M. A.* 5612 (2); *Conrad, J. et al.* 2796 (4), 2815 (9); *Cooper, G. P. & Slater, G. M.* 178 (9); *Cordero, G.* 95 (9); *Correa, M. D. et al.* 2368 (2); *Cosentino, K.* 83 (9); *Cowan, C. P.* 1721 (9), 3064 (9), 3109 (9), 3151 (9); *Cowan, C. P. et al.* 3951 (9); *Cowell, J. F.* 257 (1); *Croat, T. B.* 10593 (3), 10597 (10), 12333 (9), 12466 (8), 15895 (9), 15897 (9), 23728 (9), 24254 (9), 26599 (9), 35138 (9), 36151 (3), 36777 (9), 40192 (8), 40230 (8), 40599 (5), 40862 (9), 40956 (8 aff.), 43488 (3), 43886 (9), 47437 (10), 49785 (7), 66252 (9), 66612 (2), 66795 (2), 68307 (1), 68317 (9), 78493 (2), 78524 (9), 78545 (9); *Croat, T. B. & Hannon, D. P.* 63356 (cf. 2), 64732 (10), 65180 (8), 65332 (9), 65354 (4); *Croat, T. B. & Porter, D. M.* 15663 (9); *Croat, T. B. & Zhu, G.* 76527 (9); *Cruz, R.* 31 (1), s.n. 'WB-1176' (10). *D'Arcy, W. G.* 4239 (9), 10767 (9), 10998 (10); *D'Arcy, W. G. & Hammel, B.* 12235 (9); *D'Arcy, W. G. & Sytsma, K.* 14516 (cf. 2); *D'Arcy, W. et al.* 12658 (3); *Darío, M.* 461 (9); *Darwin, S. et al.* 2148 (1); *Davidse, G. et al.* 28277 (8), 37383 (10), 37493 (1); *Davidson, C. & Donahue, J.* 8353 (9);

APPENDIX 1. Index to Exsiccatae. Collections are listed alphabetically by collector name and then in ascending numerical order. Species are numbered as in the list provided here.

LIST OF SPECIES

1. *Urera baccifera* (L.) Gaudich. ex Wedd.
2. *U. caracasana* (Jacq.) Griseb.
3. *U. fenestrata* A. K. Monro & Al. Rodr.

- A. 796 (1), 796a (1); Schubert, B. G. & Rogerson, D. L. 846 (9); Seemann, B. C. 146 (9), 494 (7), 495 (1); Segura, M. 4 (8); Seibert, R. J. 608 (2); Seymour, F. C. 3101 (9); Shank, P. J. & Molina R., A. 4265 (8), 4405 (8); Shilom T., A. 2579 (10), 2582 (4), 2585 (5), 4173 (4); Sidwell, K. et al. 435 (10), 585 (2); Skutch, A. F. 966 (9), 982 (5), 1479 (8), 2863 (8), 3565 (3), 3602 (3), 3750 (9), 4266 (7), 4842 (9); Smith, A. A397 (10), A439 (9), A597 (9), H408 (9), H471 (9), P1988 (9), 100 (3), 158 (9), 1082 (9), 1256 (9), 1487 (9), 2788 (9); Smith, C. E. & Smith, H. M. 3380 (9); Solano, J. 23 (9), 77 (3); Solis, F. 187 (1); Soza, D. & Moreno, P. 76 (2); Soza, D. et al. 265 (2); Standley, P. C. 8354 (2), 10712 (2), 11200 (9), 11202 (1), 20526 (1), 21880 (1), 22344 (1), 22394 (1), 22764 (2), 23982 (1), 24114 (2), 30536 (1), 4136 (1), 52857 (2), 52918 (9), 53265 (1), 54051 (9), 60769 (10), 64714 (5), 67884 (5), 68232 (9), 75549 (5), 75719 (1), 76501 (10), 76980 (5), 78294 (2), 79579 (1), 79832 (10), 81009 (10), 82128 (10), 84677 (4), 86272 (5), 90615 (9), 91395 (9); Steggerda, M. 37 (5); Stevens, W. D. et al. 16650 (7), 16919 (2), 25612 (1); Stevens, W. D. & Krukoff, B. A. 4744 (2), 6428 (9), 6601 (1), 8696 (2), 8700 (1), 9284 (2), 9623 (2), 12413 (1), 12993 (1), 22708 (9); Stevenson, N. S. 109 (1); Steyermark, J. A. 29936 (9), 33332 (4), 33421 (9), 33545 (9), 34292 (4), 36257 (5), 36617 (10), 36619 (4), 37409 (4), 37516 (5), 38770 (1), 46612 (4), 47937 (9), 48785 (9), 48959 (5), 49249 (9), 51708 (5); Stocker, C. L. 21 (1); Stork, H. E. 1753 (9), 2673 (2); Sytsma, K. J. et al. 1617 (8), 1697 (9), 4982 (cf. 8).
- Tate, R. 395 (315) (1); Taylor, J. & Taylor, C. 11575 (9), 11672 (9); Taylor, K. 118 (8); Taylor, R. J. 4536 (8); Téllez, O. et al. 5181 (9), 7477 (4), 7821 (9); Téllez, O. & Pankhurst, R. 7277 (9); Terry, M. E. & Terry, R. A. 1403 (7); Todzia, C. et al. 2013 (9); Tomlin, S. 10 (2); Tonduz, A. 7167 (2), 11710 (10); Tucker, J. M. 965 (1); Tún O., R. R. 383 (1), 1080 (9), 1323 (8), 2689 (9); Tyson, E. L. 882 (9), 1741 (2), 6869 (cf. 9); Tyson, E. L. et al. 4478 (8).
- Utley, J. & Utley, K. 635 (2), 1173 (8), 2319 (3), 2352 (3), 2417 (9), 2892 (2), 5344 (2).
- Valerio, M. 1014 (10); van der Werff, H. & Herrera, J. 6187 (9); van Severen, M. L. 113 (2); Vanderveen, B. D. 605 (9); Vargas, E. et al. 392 (9); Vaughan, J. et al. 605 (9); Vega, S. & Quezada, B. 167 (2); Ventur, P. 289 (5) (9); Ventura A., F. 20686 (4), 20944 (cf. 4); Ventura L., E. & López, E. 1901 (2); Verhoek, S. E. 5493 (7); von Hagen, C. & von Hagen, W. 2083 (2); von Tuerckheim, H. 1243 (9); von Wedel, H. 842 (1).
- Webster, G. L. et al. 12326 (2), 12688 (9); Weston, A. S. 2991 (10), 3782 (10), 4742 (10), 5080 (9); Weston, A. S. et al. 3104 (8); Whitefoord, C. 1081 (9), 1613 (1), 1881 (9), 3248 (9), 3250 (9); Whitefoord, C. & Eddy, A. 249 (1); Wilbur, R. L. et al. 13014 (10); Williams, L. O. & Córdoba, J. J. 4668 (3); Williams, L. O. et al. 21816 (10), 25249 (10), 26295 (4), 28917 (10), 28972 (3), 29009 (2); Williams, R. S. 692 (1), 716 (10), 728 (9), 794 (9), 815 (10); Wilson, M. R. 40944 (10); Wilson, P. 97 (9), 579 (1); Woodson, R. E., Jr. & Schery, R. W. 257 (3), 593 (3), 863 (9); Woodson, R. E., Jr. et al. 1005 (9), 1923 (8); Wright, C. s.n. (1).
- Yuncker, T. G. 4514 (9), 5044 (2); Yuncker, T. G. et al. 8025 (9), 8454 (8), 8481 (9).
- Zamora, N. 625 (3); Zuniga, R. et al. 180 (9).

A REVIEW OF THE GENUS *DISTICTELLA* (BIGNONIACEAE)^{1,2}

Amy Pool³

ABSTRACT

Distictella Kuntze is a genus of 18 species in the tribe Bignonieae. The species are lianas or less frequently shrubs, and can be recognized by their terete branchlets without interpetiolar glandular fields; usually bifoliolate or less frequently unifoliolate or trifoliolate leaves, often with a trifid terminal tendril; terminal or less frequently lateral inflorescences; usually glandular, campanulate, + truncate calyces; tubular-infundibular or tubular-campanulate, strongly curved corollas that are white or less frequently purple, often with a yellow throat, pubescent externally and usually internally; ovaries and styles sericeous and poorly demarcated; woody capsules that are non-echinate, and often with both valves convex (slightly compressed) or one convex and one concave and the fruits curving; and bialate seeds (wings sometimes greatly reduced), brown to black, irregularly ridged, and glabrous. Relationships with similar genera are discussed, and a key to the species of *Distictella*, species descriptions, and species distribution maps are provided. The relationships of the species are also discussed, and a new species, *D. lohmanniae* A. Pool, and new variety, *D. racemosa* (Bureau & K. Schum.) Urb. var. *translucida* A. Pool, are proposed. *Bignonia rusbyi* Britton ex Rusby, *Distictis angustifolia* K. Schum. ex Sprague, *Distictella lutescens* C. V. Freire & A. Samp., and *Distictella negrensis* C. V. Freire & A. Samp. are presented as new synonyms of *Distictella racemosa* var. *racemosa*. *Distictella broadwayana* Urb. is presented as a new synonym of *Distictella racemosa* var. *translucida*, and a lectotype is designated for *Distictis racemosa* Bureau & K. Schum.

Key words: Bignoniaceae, *Distictella*, IUCN Red List, Pithecocteniinae.

Distictella Kuntze is a tropical South American genus of 18 species in the tribe Bignonieae that can generally be recognized by the combination of a number of vegetative, floral, and fruiting characters. As most members of the tribe Bignonieae, *Distictella* has bilocular ovaries, and fruits that dehisce parallel to the septum (Gentry, 1980c), and most of the species (as most Bignonieae; Gentry, 1980c) are lianas with compound leaves with the terminal leaflet modified into a tendril. The exceptions are *D. monophylla* Sandwith and *D. laevis* (Sandwith) A. H. Gentry, which are always shrubs, erect to semi-scandent, and *D. campinae* A. Samp. and *D. cuneifolia* (DC.) Sandwith, which are sometimes described as scandent shrubs or as low lianas. *Distictella monophylla* always has unifoliolate leaves and no signs of a tendril, while *D. laevis* can have either unifoliolate or bifoliolate leaves. The bifoliolate leaves of *D. laevis* have a terminal scar or residual tendril. *Distictella campinae* usually has bifoliolate leaves with terminal tendrils common; however, the lowest leaves of a branchlet are

sometimes unifoliolate. All material of *D. cuneifolia* observed in this study had bifoliolate leaves, with a common presence of tendrils. All other *Distictella* are lianas with bifoliolate leaves (*D. reticulata* A. H. Gentry is reported to occasionally have trifoliolate leaves; Gentry, 1978b), with a trifid terminal tendril.

All species of *Distictella* have terete (to somewhat flattened) branchlets and lack interpetiolar glandular fields. Most have inconspicuous pseudostipules that are lost early, but in *D. arenaria* A. H. Gentry and *D. chocoensis* A. H. Gentry, they are often foliaceous and more persistent. The leaflets are always lepidote and often have additional glands. The species vary in leaflet shape, especially the base, size, venation, and distribution and size of trichomes, and these characters are often very useful in differentiating between the species.

The inflorescence is usually a raceme or racemose panicle, frequently elongate, with numerous flowers, but with only one to three flowers blooming simultaneously. *Distictella pauciflora* A. H. Gentry,

¹This paper is number 15 of the Gentry Invitation Series, in acknowledgment of the contributions to the study of the Bignoniaceae made by Alwyn H. Gentry.

²I thank the staff of the following herbaria for providing loans of herbarium specimens: AAU, B, BM, BR, C, CAS, CGE, CM, F, FTG, G, GH, GOET, K, L, M, MICH, NY, RB, S, TEX, U, UPS, US, W, and Peter J. Stafford, Piet Stoffelen, Timothy Harris, Serena Marner, and Peter Phillipson for searching for specific specimens and providing me with digitized images. I thank W. D. Stevens for his advice and helpful comments on the manuscript, Duan Bills for help in preparing the species distribution maps, and Bee Gunn for drawing and Fred Keusenkothen for digitizing the illustration. I give particular thanks to the technical staff at the Missouri Botanical Garden whose work made the specimens available for study and who entered a large percentage of the specimens into the Tropicos database. Financial support was provided by the National Science Foundation (grant 57298).

³Missouri Botanical Garden, P.O. Box 299, St. Louis, Missouri 63166-0299, U.S.A. amy.pool@mobot.org.
doi: 10.3417/2006156

known only from the type, differs from the other species in its depauperate inflorescence, and a few species (*D. campinae*, *D. laevis*, and *D. monophylla*) tend to have smaller inflorescences but (except sometimes *D. monophylla*) produce several flowers that bloom over a period of time. The flowers of all species of *Distictella* are very similar, and no floral character was found useful in differentiating between species. The calyces are campanulate, pubescent, \pm apically truncate and denticulate, and usually have distinct glandular fields. The corollas are strongly curving, infundibular (rarely campanulate), pubescent externally and internally above a glabrous, cylindrical base, and are usually white with a yellow throat. A few species are known to have purple corollas: the only collection of *D. pauciflora* has purple flowers, and purple flowers are common in *D. monophylla* and rare in *D. mansoana* (DC.) Urb. and *D. racemosa* (Bureau & K. Schum.) Urb. var. *translucida* A. Pool. The four stamens and stigma are included, with the stamens and staminode inserted at about the same level in the corolla tube. The points of attachment are marked by villous clusters of trichomes or papillae. The nectary disc is large, annular-pulvinate and is sometimes topped with a narrow ovary stipe. The presence or absence of a stipe does not appear to be consistent enough to use to separate species. The ovary and style are covered with appressed trichomes and are difficult to differentiate from each other.

The capsules of *Distictella* are oblong or elliptic (or rarely weakly spatulate), woody, non-echinate, and usually pubescent. *Distictella magnoliifolia* (Kunth) Sandwith is unusual in having a glabrescent capsule. The valves may be convex or slightly to strongly compressed, or one valve convex and one concave resulting in a curved fruit. The shape of the capsule, especially the apex, curving or not curving, drying color, and nature of the midrib are useful characters in recognizing the species. The seeds are bialate and brown with irregular ridges on both the wing and body. In some taxa (*D. campinae*, *D. cremersii* A. H. Gentry, and *D. racemosa* var. *racemosa*), the wings are slightly to greatly reduced, opaque, and subcoriaceous. More often, the seeds are distinctly transversely oblong with the wings well developed, membranous, and hyaline. The wing may be well demarcated from the seed body or not. Seed characters are very useful in recognizing the taxa.

Early authors (Bureau, 1864; Bentham, 1876) recognized this genus based on fruit and seed characters, but Schumann (1894), Melchior (1927), and Gentry (1976) placed more emphasis on vegetative and floral characters; the terete stem combined with curved flowers serve to separate *Distictella* from its closest relatives, probably *Pithecoctenium* Mart.

ex Meisn. and *Distictis* Mart. ex Meisn. (Gentry, 1976).

Bureau and Schumann (1896) and Sampaio (1935) placed a great deal of emphasis on inflorescence type and number and arrangement of calyx glandular fields in distinguishing the species within *Distictella*. Sandwith (1953) suggested that the inflorescence type was not a useful character in this genus, as in many species there is a full range from racemes to racemose panicles, and Gentry (1982) found the number of glandular fields on the calyx to be as variable in the flowers of an individual inflorescence as between species. Neither character was found to be useful in this study. Sandwith (1957) and Gentry (1980b) both stressed that the flowers of all species of *Distictella* are very similar and are not useful in distinguishing the species. Sandwith (1963) commented that most species in the genus are based on vegetative characters and stated, "It is significant that the floral characters of all these plants seem to be essentially the same, apart from minor differences of measurement, nor does it seem probable that the fruits and seeds will afford good taxonomic distinctions" (1957: 363). In 1963, he went further in suggesting that the differences in vegetative characters might "be induced by habitat and other causes" (Sandwith, 1963: 49). This study has found a strong species specificity to particular habitats, but has also found strong fruit and seed characters that correlate with the vegetative ones. Gentry, in his new species descriptions (1978a, b, 1980b) and in his keys in floristic works (1982, 1997), placed great emphasis on vegetative characters. Gentry (1980b: 101) stated, "All species of *Distictella* have very similar flowers and are distinguished primarily by type of pubescence of the vegetative parts and to a lesser extent by fruits. While pubescence characters are notoriously plastic in many genera of Bignoniaceae, in *Distictella* they are highly constant and correlated with distinctive ecologically and geographically defined entities." This study basically agrees with this statement, but places more importance in the fruit and seed characters, and includes other vegetative characters, especially habit and leaflet number, shape, and venation.

HISTORY

Kuntze (Post & Kuntze, 1904) published the genus name *Distictella*, recognizing seven species (but not naming them) and citing in synonymy *Distictis* sensu Bureau (non Meisn.). No description was provided; Bureau's 1864 description of *Distictis* serves as the validating description of *Distictella*. In 1965, Sandwith chose *Distictella mansoana* as the lectotype.

In 1864, Bureau described *Distictis* as having a tomentose and curved capsule, with one valve convex and the other concave. This description was at odds with that of Meisner (1840), who described the capsule of *Distictis* as glabrous and nearly flat. Bureau (1864) also described the new genus *Macrodiscus* Bureau (= *Distictis*) and compared *Distictis* sensu Bureau (= *Distictella*) to *Macrodiscus* (= *Distictis*). *Distictella* (as *Distictis*) was separated from *Distictis* (as *Macrodiscus*) primarily on fruit characters, the capsule of *Distictella* being pubescent (vs. glabrous) and curved with one convex and one concave valve (vs. uncurved) with raised midrib in place of a furrow, replum ends attached to the septum (vs. free), seeds pubescent (vs. glabrous), with relatively longer wings, and seed scars on the septum linear (vs. punctiform) (Bureau, 1864).

Bentham (1876) included both *Macrodiscus* and *Distictis* sensu Bureau in his concept of the genus *Distictis*, in which he identified three groups: (1) *Distictis arthrerion* (Mart.) DC. (= *Arrabidaea arthrerion* (Mart.) Bureau ex K. Schum.); (2) *Distictis mansoana* (DC.) Bureau ex B. Verl. (= *Distictella mansoana*) and *Distictis elongata* (Vahl) Bureau ex Benth. (= *Distictella elongata* (Vahl) Urb.); and (3) a *Macrodiscus* group, *Distictis lactiflora* (Vahl) DC., *Distictis rigescens* (Jacq.) DC. (= *Distictis lactiflora*), and *Bignonia gnaphalanthia* A. Rich. (= *Distictis gnaphalanthia* (A. Rich.) Greenm.), noting the curved versus uncurved capsules in distinguishing between groups two and three.

Baillon (1891), Schumann (1894), and Bureau and Schumann (1896) recognized and carried on Bureau's misapplication of *Distictis* and *Macrodiscus*. Baillon (1891) treated *Distictella* (as *Distictis*) and *Distictis* (as *Macrodiscus*) as closely related, *Distictella* differing from *Distictis* in having more coriaceous calyces and corollas, and curved fruits. In his concept of *Distictella* he included: *Bignonia arthrerion* Mart. (= *Arrabidaea arthrerion*), *B. elongata* Vahl (= *Distictella elongata*), *B. laurifolia* Vahl (= *Paragonia pyramidata* (Rich.) Bureau; Gentry, 1977), *Pithecoctenium cuneifolium* DC. (= *Distictella cuneifolia*), *B. magnoliifolia* Bureau (ined., possibly referring to *B. magnoliifolia* Kunth = *Distictella magnoliifolia*), *B. mansoana* DC. (= *Distictella mansoana*), and, with question, *B. kerere* Aubl. (= *Mansoa kerere* (Aubl.) A. H. Gentry).

Schumann (1894) separated *Distictis* (as *Macrodiscus*) from *Pithecoctenium*, *Distictella* (as *Distictis*), and other related genera based on floral characters: the membranous to subcoriaceous corolla not curving at a right angle versus coriaceous corolla bent at nearly a right angle. *Distictella* (as *Distictis*) was separated from *Haplolophium* Cham. and *Pithecocte-*

nium based on its terete stem, which lacks ribs that separate with age, and by its curved fruit. Schumann (1894) treated two species: *Distictis elongata* and *D. mansoana*.

In *Flora Brasiliensis*, Bureau and Schumann (1896) recognized seven species in *Distictis* sensu Bureau: *Distictis mansoana* (= *Distictella mansoana*), *Distictis elongata* (= *Distictella elongata*), *Distictis racemosa* Bureau & K. Schum. (= *Distictella racemosa*), *Distictis guianensis* Klotzsch ex Bureau & K. Schum. (= *Distictella parkeri* (DC.) Sprague & Sandwith), *Distictis granulosa* Bureau & K. Schum. (retained in *Distictis*; Pool, 2007), *Distictis crassa* Bureau & K. Schum. (referred to *Arrabidaea*; Sprague, 1911; Sandwith, 1968), and *Distictis glaziovii* (Bureau ex K. Schum.) Bureau & K. Schum. (= *Haplolophium glaziovii* (Bureau ex K. Schum.) A. H. Gentry). In their key to species, Bureau and Schumann (1896) placed emphasis on the type of inflorescence as well as the presence and arrangement of calyx glandular fields, characters that were found, in this study, to be variable within a species. Bureau and Schumann (1896) also used leaflet shape, base, and pubescence, characters that were also found to be useful in this study.

Urban (1916a) made the combinations in *Distictella* for *Distictis mansoana*, *Distictis guianensis* (= *Distictella parkeri*), *Distictis crassa* (referred to *Arrabidaea*), *Distictis elongata*, *Distictis granulosa* (retained in *Distictis*), *Distictis racemosa*, *Distictis kochii* Pilg. (= *Distictella magnoliifolia*), and *Distictis angustifolia* K. Schum. ex Sprague (= *Distictella racemosa* var. *racemosa*) and published *Distictella broadwayana* (= *Distictella racemosa* var. *translucida*).

Melchior (1927) treated *Distictella* in his subtribe Pithecocteniinae, which also included *Pithecoctenium*, *Neves-armondia* K. Schum. (= *Pithecoctenium*), *Urbanolophium* Melch. (= *Haplolophium*; Gentry, 1992), *Haplolophium*, *Glaziovia* Benth. & Hook. f., and *Amphilophium* Kunth. The subtribe was described as having bifoliolate or trifoliolate leaves; tendrils usually trifid (rarely bifid), or additionally forked, and often with disk-like tips; the calyx thickly coriaceous and densely tomentose, with or without defined lobes; the corolla coriaceous, and, except in *Amphilophium*, densely pubescent, often curved at a right angle and sometimes ± bilabiate; and the capsule oblong-elliptic, flattened, the surface smooth or rough to echinate, and the seed with a membranous wing. *Pithecoctenium* (including *Neves-armondia*) and *Distictella* were placed close together based on their similar pollen and calyces and separated from each other based on the terete (vs. hexangular) stem and curved (vs. not curved) fruit of *Distictella*.

Sampaio (1935) published a key to the species of *Distictella*, as recognized by Urban (1916a), adding the new species *D. campinae* and the new combination *D. rosea* (Kraenzl.) A. Samp. (based on *Distictis rosea* Kraenzl. – *Distictis granulosa* Bureau & K. Schum.; Pool, 2007). Sampaio's (1935) key, following Bureau and Schumann (1896), placed a great deal of emphasis on inflorescence type and number and arrangement of calyx glandular fields, with some lesser emphasis on leaflet shape, base, and pubescence. In 1936, Sampaio and Freire published two new species in *Distictella*, *D. lutescens* C. V. Freire & A. Samp. and *D. negrensis* C. V. Freire & A. Samp. (both treated here as *D. racemosa* var. *racemosa*).

Sprague and Sandwith (1932) published the combination *Distictella parkeri*, placing *Distictis guianensis* in its synonymy. Sandwith went on to make two additional recombinations in *Distictella*, *D. magnoliifolia* (1938b) and *D. cuneifolia* (1953), and published five new species: *D. pulverulenta* Sandwith (Sandwith, 1938c; – *Distictis pulverulenta* (Sandwith) A. H. Gentry), *D. dasytricha* Sandwith (Sandwith, 1953), *D. monophylla* Sandwith and *D. obovata* Sandwith (Sandwith, 1957), and *D. porphyrotricha* Sandwith (1963), and one new variety, *D. monophylla* var. *laevis* Sandwith (Sandwith, 1957; = *Distictella laevis*). Sandwith relied heavily on vegetative characters in defining his new taxa, primarily habit, pubescence, and leaflet shape, size, and venation. He also provided an interesting comparison of *Distictella*, *Pithecoctenium*, and *Anomoctenium* Pichon (– *Distictis*), emphasizing for *Distictella* the terete branchlets with fine ribs that do not separate; simple trichomes; corolla tube lacking glandular fields; non-echinate, pubescent capsule; and seeds with irregular ridges and brown wings (Sandwith, 1965).

Gentry published five new species of *Distictella*: *D. pauciflora* (Gentry, 1974a), *D. arenaria* (Gentry, 1978a), *D. reticulata* (Gentry, 1978b), *D. cremersii* (Gentry, 1980a), and *D. chocoensis* (Gentry, 1980b). His species are again primarily recognized by vegetative characters such as pubescence and leaflet venation and shape, and to a lesser extent by characteristics of the fruit, seed, and inflorescence. Gentry (1976) moved *Distictella pulverulenta* to *Distictis* and provided an interesting discussion about the differences between these two closely related genera.

Gentry (1976) outlined the generic differences between *Distictis* and *Distictella* described by Bureau (1864) and Schumann (1894) and found when species described or transferred to *Distictis* post-Bureau (1864) were examined, the fruit differences did not correspond well with the vegetative and floral characteristics. For example, *Distictis granulosa*

Bureau & K. Schum., *D. scabriuscula* (Mart. ex DC.) A. H. Gentry, and *D. steyermarkii* A. H. Gentry all have pubescent capsules (a character of *Distictella*), but the flowers and branchlets of *Distictis* and many species of *Distictella* (such as *D. arenaria*, *D. campinae*, *D. cremersii*, *D. laevis*, *D. monophylla*, *D. obovata*, and *D. porphyrotricha*) have uncurved fruit or even a glabrescent fruit (*D. magnoliifolia*), characteristics previously associated with *Distictis*, but flowers and branchlets of *Distictella*. Gentry (1976) concluded that *Distictis* and *Distictella* were closely related and best separated by vegetative and floral characteristics.

ANATOMY

Santos (1995) studied 31 genera of Bignoniaceae and divided them into four groups based on the type of cambial variant present. The two varieties of *Distictella racemosa* (as *D. magnoliifolia*) were included in her study. *Distictella* fits into her "group 4," which is characterized by stems with discontinuous phloem wedges intersected with xylem and parenchyma (Santos, 1995: figs. 143, 144). The only other genus in this group is *Pithecoctenium*, which differs from *Distictella* (and the other genera studied) by having secondary xylem in the bark (Santos, 1995). Two other genera in the Pithecocteniinae, *Amphilophium* and *Haplolophium*, as well as *Distictis* (among a number of other genera) fell into her "group 2," having stems with multiples of four phloem wedges in transverse section. The remaining genus in Pithecocteniinae, *Glaziovina*, was not included in her study.

PALYNOLOGY

Gentry and Tomb (1979) included *Distictella racemosa* var. *racemosa* (reported as *D. magnoliifolia*) in their SEM survey of pollen types in the Bignoniaceae (Gentry & Tomb, 1979: fig. 6). From this, they concluded that *Distictella* has inaperturate, coarse-reticulate pollen (Gentry & Tomb, 1979). This is supported by the earlier traditional light microscope work of Gomes (1955) and Sandwith (1965), both of whom examined *D. mansoana* (Gomes, 1955: tab. 1, fig. 4). Urban (1916b) similarly described and illustrated the pollen of *D. racemosa* var. *translucida* (as *D. broadwayana*), but with bulges on the reticulation extending into the areoles (Urban, 1916b: tab. 21, fig. 3). Sandwith (1965: 412) suggested that Urban (1916b) confused the "bulging sinuosities of the walls with outgrowths."

Gentry and Tomb (1979) found this pollen type in a number of other genera, which they suggested could be divided into two natural groups. The one including *Distictella* is characterized by having thick-textured

white to purple or red flowers, trifold to multi-trifold tendrils, and multiseriate ovules and seeds. The other genera in the group are *Pithecoctenium* and *Distictis*, genera that Sandwith (1965) and Gentry (1976) had previously suggested as closely related. *Amphilophium*, another genus suggested as closely related (Sandwith, 1965; Gentry, 1974a), had pollen of a different type: stephanocolpate (zonocolpate) with coarse reticulation (Gentry & Tomb, 1979), a pollen type shared with *Glazivia* and *Haplolophium* (including *Urbanolophium*), all of which are characterized by a frilly outer calyx margin, unique in the family (Gentry & Tomb, 1979).

GENERIC PLACEMENT

Melchior (1927) established the subtribe Pithecocteniinae, which included *Distictella*, *Pithecoctenium*, *Neves-armondia* (– *Pithecoctenium*), *Urbanolophium* (– *Haplolophium*; Gentry, 1992), *Haplolophium*, *Glazivia*, and *Amphilophium*. *Distictis* was not included in Melchior's concept of the subtribe, perhaps due to its less coriaceous corolla and shape of the capsule valves; the species that would have been considered to be in *Distictis* at that time, *D. lactiflora*, *D. gnaphalantha*, and *D. laxiflora* (DC.) Greenm., all have convex capsule valves that are not at all flattened. However, in other respects, *Distictis* does fit the description of the Pithecocteniinae. The molecular studies of Lohmann (2006) concur, placing all six genera in the Pithecocteniinae clade.

Distictella is probably most closely related to either *Pithecoctenium* or *Distictis*. The three genera share a common pollen type (Gentry & Tomb, 1979) and can be separated from the other members of the Pithecocteniinae by the presence of a simple calyx, without frill. *Distictella* differs from both *Pithecoctenium* and *Distictis* in its terete stem (the stem in *Pithecoctenium* and *Distictis* being hexangular with the ribs often detaching with age), inner surface of the corolla pubescent (vs. glabrous, except in *Distictis pulverulenta*), ovary poorly demarcated from style (vs. clearly demarcated), seed with brown wings (also in *D. pulverulenta* and *D. occidentalis* A. H. Gentry), and, in some species with hyaline seed wings, seeds with minute excrescences on the ridges appearing as dark-colored dots on both body and wing of seed (not known in *Distictis* or *Pithecoctenium*).

Distictella and *Pithecoctenium* both have strongly curved corollas that are nearly always white and always lack glands, have only non-branched trichomes, and share a similar type of cambial variant (Santos, 1995), while *Distictis* has straight to arching corollas that vary in color from white to purple or red and often have glandular fields, often have dendritic

trichomes, and have a different type of cambial variant.

Distictis and *Distictella* have non-echinate capsules that have the septa without raised edges and seeds bialate or distinctly transversely oblong, while *Pithecoctenium* has echinate capsules (except for *P. falcatum* (Vell.) A. Pool) that have septa with raised edges and seeds with wings clearly on three sides.

REPRODUCTIVE BIOLOGY

Gentry (1974b, 1980c) recognized 10 major morphological floral types within the Bignoniaceae, each with its own correlating pollination agent(s). Gentry (1974b) characterized the flowers of *Distictella* as falling into the *Pithecoctenium*-type or xylocopid flower. Flowers in this group tend to have calyces that are thick and often glandular; have corollas that are generally strongly bent or curved below the middle, white or cream colored, externally pubescent (above the calyx), and thick (especially at the base), with an internal sturdy ridge of thickened (perhaps glandular) trichomes at the level of the stamen insertion that nearly closes the tube; and produce abundant nectar. Gentry (1990: 122) suggested that *Pithecoctenium*-type flowers are pollinated by the same large and medium-sized bees as typical Bignoniaceae flowers but with the added advantage of the xylocopids being "converted from thieves to legitimate visitors."

Gentry (1974b) identified five different patterns of phenology in the Bignoniaceae. *Distictella* is listed in table 1 (Gentry, 1974b) as type 3 (2) and in table 2 (Gentry, 1974b) as type 2(?). Type 2 applies to steady state species; species that put out one or two flowers over a long period of time and that are probably pollinated by long-lived trap-line bees that follow a regular daily foraging route (Janzen, 1971; Gentry, 1990). There is little or no correlation of flowering time with season (Gentry, 1974b). Type 3 is a cornucopia phenology; large masses of flowers are produced over a period of time lasting from a few weeks to over a month and there is strong correlation with season (Gentry, 1974b). Species in this group have a wide array of pollinators: hummingbirds, hawkmoths, butterflies, and bees (Gentry, 1974b).

Flowers of *Distictella* are very uniform from species to species, and generally fit the *Pithecoctenium*-type, though often with a thinner corolla and with the base of the tube less markedly blocked by glandular trichomes or papillae than *Pithecoctenium*. In a few species, the calyx is also membranous (*D. laevis*, *D. monophylla*, and *D. obovata*). *Distictella pauciflora*, known only from the type, differs from other species in its depauperate inflorescence and purple flowers (purple flowers are also frequent in *D. monophylla*

and infrequent in *D. mansoana* and *D. racemosa* var. *translucida*). Most of the species have terminal (or terminal and lateral), elongate racemes or racemose panicles, 10–40 cm long with 10 to 34 flowers, but with only 1 to 3 flowers open at any one time. A few species (*D. campinae*, *D. laevis*, and *D. monophylla*) tend to have smaller inflorescences, but (except sometimes *D. monophylla*) produce several flowers that bloom over a period of time.

Phenology patterns are difficult to determine from a herbarium study, particularly for species where little or no flowering material is known (*Distictella cremersii*, *D. pauciflora*, *D. reticulata*, and *D. dasytricha*). *Distictella racemosa* var. *translucida*, *D. racemosa* var. *racemosa*, and *D. mansoana* flower nearly throughout the year over their entire range. For purposes of comparison, flowering times were compared only for the areas where most flowering collections were made: Peru for *D. racemosa* var. *translucida*; Amazonas, Brazil, for *D. racemosa* var. *racemosa*; and Minas Gerais, Goiás, and Distrito Federal, Brazil, for *D. mansoana*. Flowering for five species of *Distictella* (*D. arenaria*, *D. chocoensis*, *D. laevis*, *D. magnoliifolia*, and *D. monophylla*) does not appear to correlate with seasonality. All of these, except *D. chocoensis*, are found in white sand savannas or shrubby areas. Seven taxa of *Distictella* (*D. lohmanniae* A. Pool, *D. obovata*, *D. parkeri*, *D. cuneifolia*, *D. elongata*, *D. mansoana*, and *D. racemosa* var. *translucida*) flower primarily during the rainy season. Three taxa (*D. campinae*, *D. porphyrotricha*, and *D. racemosa* var. *racemosa*) flower primarily during the dry season or at a time of relatively less rainfall. No apparent correlations were found between wet or dry flowering seasons and soil type, vegetation type, inundation, or elevation.

Most of the species of *Distictella* have seed wings that are well developed, membranous and hyaline (at least at the tips). However, three taxa (*D. cremersii*, *D. campinae*, and *D. racemosa* var. *racemosa*) have seed wings somewhat to greatly reduced, subcoriaceous, and opaque. *Distictella cremersii* is known from riparian or seasonally inundated forests and *D. racemosa* var. *racemosa* is found in seasonally inundated forests, and it is assumed that the reduction in the wings is an evolutionary adaptation toward water dispersal. However, *D. campinae* is probably not associated with a water habitat (according to label data, except for A. H. Gentry & A. Pinheira 13130, varzea edge), and *D. cuneifolia*, from seasonally inundated savannas, *D. reticulata*, from forests along riversides, and *D. dasytricha*, from swampy forested areas, have well-developed, membranous, and hyaline seed wings.

DISTRIBUTION

Distictella is found only in tropical South America with one species also found on Tobago. Some of the species are found primarily in areas of white sand: *D. arenaria*, *D. campinae*, *D. cremersii*, *D. elongata*, *D. laevis*, *D. magnoliifolia*, *D. monophylla*, and *D. parkeri*. Three taxa are found in seasonally inundated areas: *D. cuneifolia*, *D. dasytricha*, and *D. racemosa* var. *racemosa*, and two others, *D. cremersii* and *D. reticulata*, are found on the margin of rivers. Many species are found primarily in savannas or areas with scrubby vegetation (campinas, cerrados, or pampas): *D. arenaria*, *D. campinae*, *D. cuneifolia*, *D. laevis*, *D. magnoliifolia*, *D. mansoana*, *D. monophylla*, and *D. obovata*, while the rest are found in forest. *Distictella cuneifolia* is often found in areas with an abundance of termite mounds. Most of the species of *Distictella* are found below 400 m elevation. Exceptions to this are *D. arenaria* (100–700 m), *D. mansoana* (160–1400 m, usually over 400 m), *D. monophylla* (100–1500 m), *D. obovata* (450–1600 m), *D. porphyrotricha* (900–1380 m), and *D. racemosa* var. *translucida* (100–950 m).

Most of the taxa of *Distictella* are known from limited areas, while three, *D. mansoana*, *D. racemosa* var. *racemosa*, and *D. racemosa* var. *translucida*, have much broader ranges. *Distictella mansoana* has the most southern range. It is found primarily in south-central Brazil, northern Bolivia, and southern Peru, with a few collections found in northern and central Amazonian Brazil (Fig. 1B). *Distictella racemosa* var. *racemosa* is found from northern central Amazon and the Guianas to western southern Amazon (Fig. 2B). *Distictella racemosa* var. *translucida* is found in Tobago and distributed in a western arc from the Guianas through Venezuela, Colombia, Ecuador, and Peru, and peripherally in Brazil (Fig. 2B). The three may overlap in northeastern Bolivia and central-western Brazil, but *D. mansoana* is usually found in savannas (usually described as pampas or cerrados) at higher elevations while the other two are found in forests, often at lower elevations. *Distictella racemosa* var. *racemosa* and *D. racemosa* var. *translucida* have peripherally overlapping distributions, but *D. racemosa* var. *racemosa* is found in seasonally inundated areas, while *D. racemosa* var. *translucida* is found in non-inundated areas. *Distictella cuneifolia* is found along the northern border of Bolivia with Brazil (Fig. 1A), where it may overlap with the three taxa mentioned above, but it is found in savannas or pampas, usually at lower elevations.

Several species are primarily located in central to southern Amazon (*Distictella lohmanniae*, *D. reticulata*, *D. campinae*, *D. laevis* [also southeast Vene-

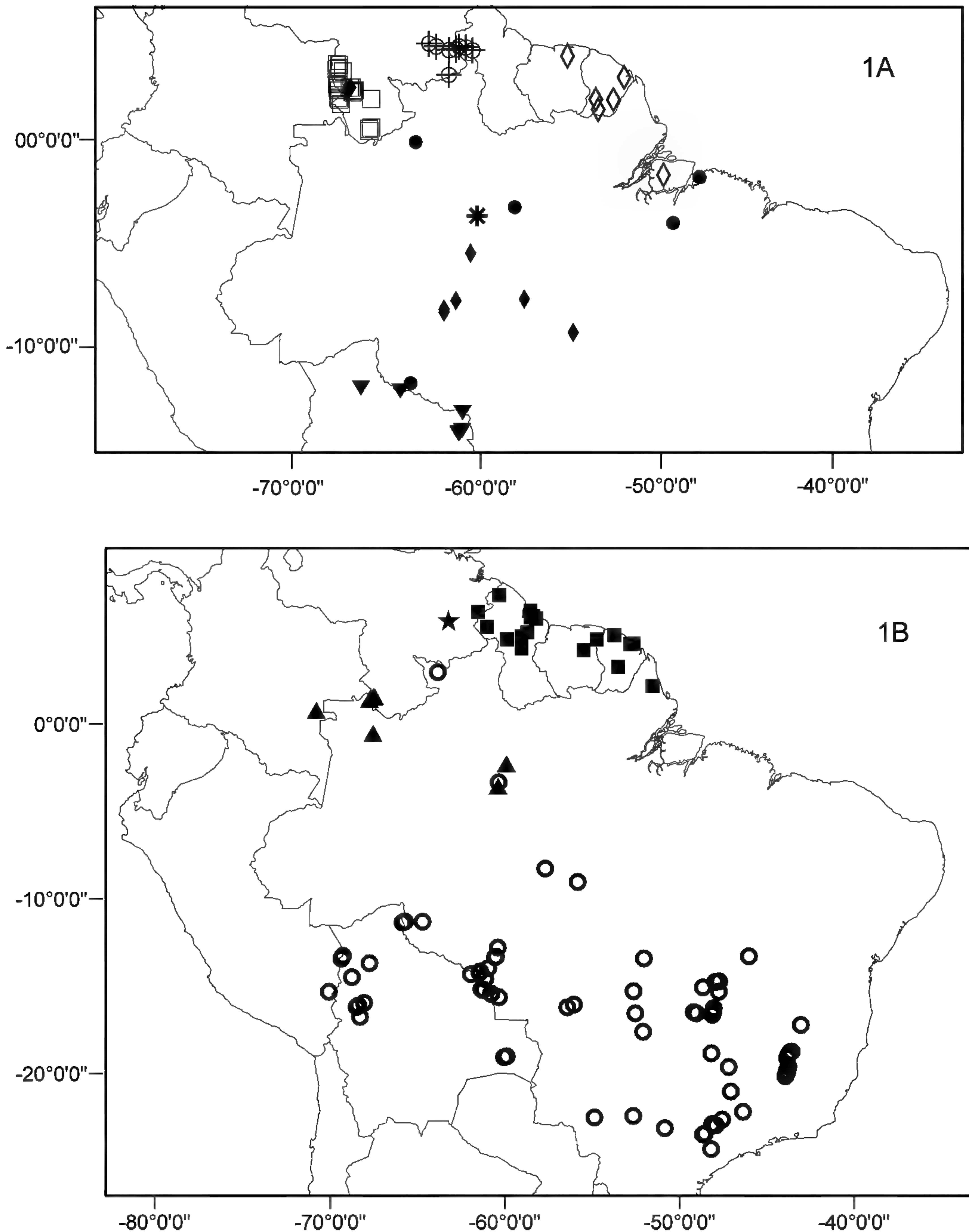

Figure 1. Distribution of selected species of *Distictella*. —A. *D. campinae* A. Samp. (●), *D. cremersii* A. H. Gentry (◇), *D. cuneifolia* (DC.) Sandwith (▼), *D. laevis* (Sandwith) A. H. Gentry (◇), *D. monophylla* Sandwith (□), *D. obovata* Sandwith (⊕), and *D. reticulata* A. H. Gentry (*). —B. *D. magnoliifolia* (Kunth) Sandwith (▲), *D. mansoana* (DC.) Urb. (○), *D. parkeri* (DC.) Sprague & Sandwith (■), and *D. pauciflora* A. H. Gentry (★).

zuela], and *D. elongata* [also Guianas]) where they overlap with *D. mansoana* and *D. racemosa* var. *racemosa*. *Distictella mansoana* is the only one of these to usually be found above 400 m elevation. *Distictella campinae* and *D. laevis* (Fig. 1A) are both

found in white sand savannas or campinas, but the present distribution suggests that the two species are isolated from each other. *Distictella magnoliifolia* (Fig. 1B), found primarily along the southern border of Venezuela with Colombia, has also been collected in

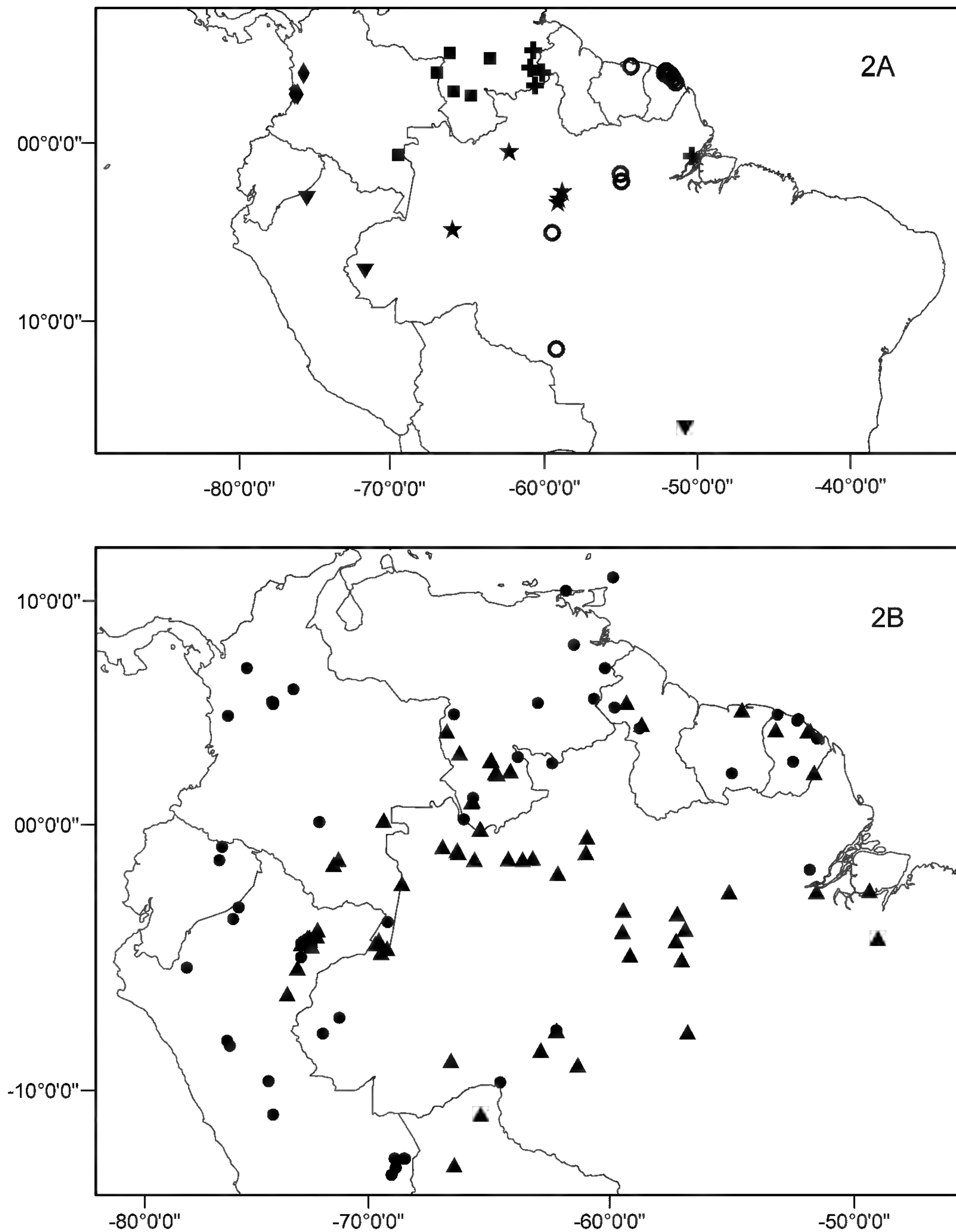

Figure 2. Distribution of selected species of *Distictella*. —A. *D. arenaria* A. H. Gentry (■), *D. chocoensis* A. H. Gentry (◆), *D. dasytricha* Sandwith (▼), *D. elongata* (Vahl) Urb. (○), *D. lohmanniae* A. Pool (★), and *D. porphyrotricha* Sandwith (⊕). —B. *D. racemosa* (Bureau & K. Schum.) Urb. var. *racemosa* (▲) and *D. racemosa* var. *translucida* A. Pool (●).

Amazonas, Brazil, where it is known from similar habitats as *D. campinae* and *D. laevis*. *Distictella elongata* (Fig. 2A) is unique in this group to white sand forests and *D. racemosa* var. *racemosa* is unique to inundated non-white sand areas. Both *D. lohmanniae* (Fig. 2A) and *D. reticulata* (Fig. 1A) are found in

non-inundated forests, apparently not associated with white sand, at low elevations.

A number of species are found in northeastern Venezuela and/or the Guianas: *Distictella porphyrotricha* (also north-Atlantic Brazil; Fig. 2A), *D. elongata* (also Brazil), *D. obovata* (Fig. 1A), *D. parkeri*

(also Amapá, Brazil; Fig. 1B), *D. pauciflora* (Fig. 1B), and *D. cremersii* (also Ilha de Marajó, Pará, Brazil; Fig. 1A) where they overlap with the widespread varieties of *D. racemosa*. Of these, only *D. obovata* and *D. racemosa* var. *translucida* are found at elevations over 500 m. *Distictella obovata* is often found in the savannas of the Pakaraima Mountains of Guyana and Gran Sabana of Venezuela, while *D. racemosa* var. *translucida* is found widespread in lowland and montane forests. Neither are associated with white sand. *Distictella parkeri*, *D. elongata*, and *D. cremersii* are found primarily in white sand forests, *D. cremersii* in riparian vegetation, probably on a peneplain of a crystalline base (Granville, 1988), *D. elongata* often in former sea beaches near the coast (in the Guianas; Granville, 1988), and *D. parkeri* often in low or disturbed forests, probably associated with schist, conglomerate, and quartzite of the Orapu-Bonidoro series (Granville, 1988). *Distictella racemosa* var. *racemosa* is known from seasonally inundated forests, and *D. porphyrotricha* and *D. racemosa* var. *translucida* are both found in non-inundated forests. The latter two might be separated by phenology, *D. porphyrotricha* flowers in the dry season and *D. racemosa* var. *translucida* in the wet season. *Distictella pauciflora* is known from only one collection.

Two species are found only in southwestern Venezuela, or southwestern Venezuela and eastern Colombia: *Distictella monophylla* (Fig. 1A) and *D. arenaria* (Fig. 2A), where they overlap with the more widely distributed *D. laevis*, *D. magnoliifolia*, *D. racemosa* var. *racemosa*, and *D. racemosa* var. *translucida*. *Distictella laevis*, *D. monophylla*, *D. magnoliifolia*, and *D. arenaria* are all known from non-seasonally inundated, white sand savannas, or campinas, and show no seasonality in flowering. *Distictella laevis* and *D. magnoliifolia* have not been found above 400 m, while *D. arenaria* ranges from 100–700 m elevation and *D. monophylla* ranges from 100–1500 m elevation.

Distictella chocoensis (Fig. 2A) is the only species of *Distictella* known from the Chocó and Valle del Cauca departments of western Colombia, where it is endemic.

I have only seen five collections of *Distictella dasytricha*. Three are from the western central Amazon of Peru and Brazil and two from Goiás (Fig. 2A). It grows in swampy forests below 500 m elevation. Its distribution pattern is not clear from the collections seen, but appears to overlap with *D. racemosa* var. *racemosa*, which is also found in inundated forests at low elevations, *D. racemosa* var. *translucida*, found in forests not seasonally inundated, and *D. mansoana*, generally found at higher elevations in non-inundated non-forest habitats.

ECONOMIC AND ETHNOBOTANICAL USE

I have found only one mention of use for *Distictella*. Schultes (1970) reported the use of *Distictella racemosa* as an ingredient in a type of curare made by the Barasana Indians living on the Río Apaporis, Colombia. The root is reported to be very toxic.

MATERIALS AND METHODS

All specimens examined by Gentry and as part of this study have been incorporated into the Missouri Botanical Garden database-management system Tropicos (<<http://www.tropicos.org/>>), which now contains label information for all *Distictella* specimens housed at MO in addition to those received on loan from: AAU, B, BM, BR, C, CAS, CM, F, FTG, G, GH, GOET, K, L, M, MICH, NY, RB, S, TEX, U, UPS, US, and W. Specimens determined by this author were selected from this database to generate the distribution maps and the Index to Numbered Exsiccatae (Appendix 1), the former with the assistance of Duan Bills. Geographic coordinates, when not stated on labels, were estimated using the Internet sites: <<http://earth-info.nga.mil/gns/html/index.html>> and <<http://www.fallingrain.com/world/>>, and wet and dry season designations were made based on Brawer (1991). Habitat descriptions are those of the plant collectors as indicated on herbarium labels.

TAXONOMIC TREATMENT

Distictella Kuntze in T. Post & Kuntze, Lex. Gen. Phan. 182. 1904 [1903]. TYPE: *Distictella mansoana* (DC.) Urb. (lectotype, designated by Sandwith, 1965: 412).

Lianas or rarely shrubs; branchlets terete, without interpetiolar glandular fields; pseudostipules usually inconspicuous, short and thick. Leaves usually bifoliolate with a terminal trifid tendril present or absent, or rarely unifoliolate or trifoliolate. Inflorescence a terminal or lateral raceme or racemose panicle; calyx campanulate, truncate, sometimes with minute denticules, usually with glandular fields below the apical margin; corolla usually white with yellow throat (sometimes purple), infundibular (rarely campanulate) from a cylindrical, glabrous base, strongly curving 1/5–1/2 length from base, externally densely minutely pubescent above cylindrical base, internally usually densely minutely pubescent (rarely nearly glabrous, sometimes also lepidote) above cylindrical base, and usually with clusters of trichomes at bases of stamens and staminode; stamens 4, inserted at approximately the same level in the corolla tube, dithecal, the thecae divaricate, glabrous, small

staminode inserted at approximately the same level as the stamens; disc annular-pulvinate; ovary oblong, sericeous with minute appressed trichomes, sometimes with a narrow stipe, ovules 4- to 8-seriate in each locule, style pubescent to apex, poorly demarcated from ovary. Capsule oblong, elliptic, or weakly spatulate, woody, non-echinate, both valves convex, one valve convex and the other concave

resulting in a curved fruit, or both valves slightly to strongly compressed, septum parallel to valves, without raised edges; seeds bialate, shades of brown, with irregular ridges (often appearing with irregular dark-colored dots) on both wing and body, glabrous, wings well to poorly demarcated from seed body, sometimes greatly reduced, often thin, hyaline to opaque.

KEY TO SPECIES OF *DISTICTELLA*

- 1a. Leaves unifoliolate, or bifoliolate and petiolules absent to 2 mm long.
 - 2a. Unifoliolate, abaxial surface of leaflets densely pubescent with small trichomes and with the tertiary and higher order venation conspicuous and strongly raised, forming a fine, closed network 12. *D. monophylla*
 - 2b. Unifoliolate and/or bifoliolate, abaxial surface of leaflets without trichomes (or with trichomes at base of midrib) and with the tertiary and higher order venation flat or immersed, inconspicuous and loosely open-reticulate.
 - 3a. Lateral veins initiating at a 70°–90° angle with the midrib, extending in a nearly straight line toward margin, before looping to meet next lateral vein, strongly brochidodromous; seeds 7–8 × 11–12 mm, wings greatly reduced, subcoriaceous and opaque 2. *D. campinae*
 - 3b. Lateral veins initiating at a 45° angle with the midrib, curving toward apex before anastomosing with tertiary veins, or weakly brochidodromous; seeds 10–14 × 25–28 mm, wings well developed, membranous and hyaline 8. *D. laevis*
- 1b. Leaves bifoliolate with petiolules 4 mm long or longer.
 - 4a. Abaxial surface of leaflets without trichomes or with trichomes restricted to axils of lateral veins with midrib and sometimes also along midrib.
 - 5a. Inflorescence greatly reduced, type with one terminal flower and one flower from axil of uppermost leaf 15. *D. pauciflora*
 - 5b. Inflorescence a raceme or racemose panicle.
 - 6a. Low lianas or scandent shrubs; leaflets 4.7–11.5 × 1.6–5 cm; fruits 5–6.7 cm long; found in savannas, campinas, or pampas.
 - 7a. Lateral veins initiating at a 70°–90° angle with the midrib, extending in a nearly straight line toward margin, before looping to meet next lateral vein, strongly brochidodromous; seeds 11–12 mm wide, wings greatly reduced, subcoriaceous and opaque; endemic to Amazonian Brazil, where it is found in savannas or campinas, on white sand 2. *D. campinae*
 - 7b. Lateral veins initiating at a 45°(60°) angle with the midrib, curving toward apex before anastomosing with tertiary veins, or weakly brochidodromous; seeds 26–28 mm wide, wings well developed, membranous and hyaline; endemic to Bolivia, where it is found in savannas or pampas, on black, silty soils 5. *D. cuneifolia*
 - 6b. Lianas; leaflets 8–24 × 3.3–12.5 cm; fruits 7–22 cm long; found in forests, or *D. magnoliifolia* found in scrubby or low forests or savannas.
 - 8a. Leaflets coriaceous with 2 to 4 pairs of lateral veins, tertiary veins raised on both surfaces; fruit drying black, nearly without trichomes, narrowly oblong, 2–2.5 cm wide, apex long attenuate, wall 1–2 mm thick; growing in scrubby or low forests or savanna 10. *D. magnoliifolia*
 - 8b. Leaflets chartaceous to subcoriaceous with 4 to 9 pairs of lateral veins, tertiary veins flat to immersed on both surfaces; fruit drying yellowish green, greenish gold, golden brown, or reddish brown, densely pubescent, broadly elliptic to oblong or oblanceolate, 3.5–7 cm wide, apex acute, obtuse, rounded, or obtuse and apiculate, wall 3–5 mm thick; growing in forests.
 - 9a. Fruits usually curved with one valve concave and the other convex; seeds 2.5–4.5 times as wide as long, wings membranous and hyaline; growing in non-inundated areas 17b. *D. racemosa* var. *translucida*
 - 9b. Fruits not curved, valves convex or slightly compressed; seeds less than 2 times as wide as long, wings subcoriaceous to coriaceous and opaque; growing in seasonally inundated areas or riparian habitats.
 - 10a. Abaxial surface of leaflets with clusters of trichomes in the axils of the lateral veins with the midrib, glandular fields absent; seeds 14–16 × 12–20 mm, wings nearly totally reduced, reddish brown or reddish black; endemic to the Guianas and Ilha de Marajó, Pará, Brazil 4. *D. cremersii*
 - 10b. Abaxial surface of leaflets without trichomes, usually with glandular fields at the apex and in the axils of the basal lateral veins with the midrib; seeds 15–28 × 24–45 mm, wings developed, brown or gray; widespread throughout greater Amazonian South America 17a. *D. racemosa* var. *racemosa*
 - 4b. Abaxial surface of leaflets pubescent over entire surface.
 - 11a. Longest trichomes of branchlets and petioles 1–2 mm long.
 - 12a. Adaxial surface of leaflets flat, lateral veins initiating at a 20° angle with midrib, higher order venation forming a very fine, closed network; trichomes of branchlets, petioles, petiolules, and

- inflorescence golden in color; bracteoles lost prior to anthesis; fruit curved with obtuse to rounded apex and prominent midrib; found in swampy areas below 500 m 6. *D. dasytricha*
- 12b. Adaxial surface of leaflets bullate, lateral veins initiating at a 45° angle with midrib, higher order venation forming a loosely closed network; trichomes of branchlets, petioles, petiolules, and inflorescence ferruginous; bracteoles persistent in flower; fruit not curved, with acuminate apex and without a prominent midrib; found in terra firme forests between 900 and 1400 m 16. *D. porphyrotricha*
- 11b. Longest trichomes of branchlets and petioles 0.03–0.7 mm long.
- 13a. Tertiary veins immersed to flat on abaxial surface of leaflet.
- 14a. Leaflets drying bicolored, the adaxial surface blackish green, abaxial surface covered with appressed trichomes to 0.03 mm long, lateral veins initiating at a 20° angle with midrib, tertiary veins generally parallel, closely set, and non-branching; capsule slightly curved with prominent midrib; seed with wings well demarcated from seed body; found in terra firme forests, Amazonas, Brazil 9. *D. lohmanniae*
- 14b. Leaflets drying a similar color on both surfaces, + brownish green, abaxial surface tomentose with trichomes to 0.15–0.2 mm long, lateral veins initiating at a 45° angle with midrib, tertiary veins generally branching, not conspicuously closely set, and parallel; capsule strongly curved with midrib, not at all evident to subevident; seed with wings poorly demarcated from seed body; found primarily in white sand forests, the Guianas, Bolívar, Venezuela, and Amapá, Brazil 14. *D. parkeri*
- 13b. Tertiary veins raised on abaxial surface of leaflet.
- 15a. Leaflets obovate or oblanceolate (rarely elliptic) with the base cuneate or shortly attenuate; capsule with an acuminate apex.
- 16a. Leaflets chartaceous to subcoriaceous with a flat margin, lateral veins initiating at a 20° angle with midrib, adaxial surface not drying glossy; inflorescence paniculate; fruit curving with one valve convex and the other concave, drying golden brown with prominent midrib; found between 0 and 200 m in French Guiana, Suriname, and Brazil 7. *D. elongata*
- 16b. Leaflets rigidly coriaceous with a recurved margin, lateral veins initiating at a 45° angle with midrib, adaxial surface drying glossy; inflorescence a raceme; fruit not curving, both valves somewhat compressed, drying dull black with midrib subevident; found between 450 and 1660 m in the region of the Pakaraima Mountains of Guyana and adjacent Bolívar, Venezuela 13. *D. obovata*
- 15b. Leaflets ovate, lanceolate, or elliptic with the base rounded to cordate (sometimes + acute in *D. mansoana*); capsule with apex acute or obtuse (not known in *D. chocoensis*).
- 17a. Abaxial surface of leaflets with tertiary and higher order venation similarly raised 18. *D. reticulata*
- 17b. Abaxial surface of leaflets with tertiary veins more raised than higher order venation.
- 18a. Tertiary and higher order venation inconspicuous and usually raised on adaxial surface, usually inconspicuous and always raised on abaxial surface forming a loosely closed network; pseudostipules narrow (width 1/5–1/3 length), rarely present; fruit curving with a prominent midrib; seeds with wings well demarcated from seed body; known from Brazil, Bolivia, and Peru 11. *D. mansoana*
- 18b. Tertiary and higher order venation immersed in adaxial surface, conspicuous and raised on abaxial surface forming a medium to fine closed network; pseudostipules broad (width 1/2 to equal length), often present; fruit not curving, midrib not evident or subevident (not known in *D. chocoensis*); seeds with wings poorly demarcated from seed body (not known in *D. chocoensis*); known from Venezuela and Colombia.
- 19a. Petiolules longer than petioles; tertiary veins branching; often growing on white sand in disturbed areas, known from southern Venezuela and eastern Colombia 1. *D. arenaria*
- 19b. Petiolules shorter than petioles; tertiary veins not branching; known from wet forests of western Colombia 3. *D. chocoensis*

1. *Distictella arenaria* A. H. Gentry, Mem. New York Bot. Gard. 29: 273. 1978. TYPE: Venezuela. Amazonas: 18 km S of Samariapo toward Río Sipapo, 125 m, 29 June 1975, A. H. Gentry & P. Berry 14615 (holotype, MO!; isotype, NY not seen, digitized image!, VEN not seen).

Liana; young branchlets terete, drying dull brown or black, usually solid, lepidote, pilose or puberulent or

with erect or ascending trichomes; trichomes white, tan, or ferruginous, 0.1–0.7 mm; pseudostipules usually present, asymmetrically orbicular or broadly ovate, thick, 3–10 × 3–5 mm, the tip usually curving strongly downward. Leaves bifoliolate, trifid tendril sometimes present; petiole 5–15 mm, with pubescence like that of branchlets; petiolules 8–27 mm, with pubescence like that of branchlets; leaflets

lanceolate or ovate, 7–19 × 4.4–11.5 cm, chartaceous to subcoriaceous, 4 or 5 pairs of lateral veins, each lateral vein initiating at a 45°–60° angle with the midrib and gradually curving upward toward margin and anastomosing with tertiary veins, tertiary veins conspicuous, anastomosing with higher order venation to form a fine, closed network, all veins immersed adaxially and raised abaxially, both surfaces drying yellow-green or olive, adaxial surface with midrib, and often lateral veins, pubescent, inconspicuously but abundantly lepidote, with or without scattered glands, abaxial surface pilose or with erect to spreading, white trichomes, 0.1–0.3 mm, abundantly lepidote, usually with fields of glands in most of the axils of the lateral veins with the midrib, margin flat, base cordate, subcordate, or rounded, apex acute or obtuse with tip cuspidate or apiculate. Inflorescence a raceme (rarely racemose panicle), peduncle with rachis 9.5–23 cm with 10 to 27 flowers, peduncle ca. 3 mm wide at base, peduncle, rachis, and pedicels drying reddish brown, with pubescence like that of branchlets or minutely puberulent, lepidote, bracteoles absent or not seen; calyx 8–10 × 8–10 mm, subcoriaceous, with minute, appressed, ferruginous trichomes and densely lepidote, glandular fields 2 or 2.5 pairs; corolla white with yellow throat, infundibular from cylindric base, curved 1/3 distance from base, 4.5–5.5 cm, chartaceous, tube 3.2–4.2 cm with cylindric base 9–12 mm long and mouth 14–15 mm wide, externally and internally pubescent with minute trichomes above glabrous base, internally with clusters of glandular papillae or villous at bases of stamens and staminode, lobes 11–15 × 11–12 mm; stamens and staminode inserted 9–10 mm from base of corolla tube, anthers 4–4.5 mm, longer filaments 24–28 mm, shorter filaments 18–25 mm, staminode ca. 4 mm; disc ca. 1 × 3.5–5 mm; pistil 3.4–4 cm, ovary 3.5–5 × 2–2.5 mm, stipe 0.5–1.5 mm, stigma lanceolate. Capsule oblong, not curved, 7.5–11 × 2.5–3 cm, ca. 0.3 cm diam., base acute and truncate, apex acute, valves fairly strongly compressed, drying reddish or golden brown, puberulent with minute, white or ferruginous trichomes, glandular and warty, midrib subevident or not at all evident, wall ca. 2 mm thick. Seeds 10–18 × 32–55 mm, wings poorly demarcated from seed body, reddish brown with tips lighter brown, membranous, hyaline, especially at tips, the veins contrasting in color to surface.

Distribution. *Distictella arenaria* is known from southern Venezuela (Bolívar and Amazonas) and eastern Colombia (Vaupés and Vichada). It has been reported from thickets on white sand, shrubby islands in savanna, and road and stream sides, at elevations ranging from 100 to 700 m. Figure 2A.

Phenology. Flowering June, December, and January; fruiting November and March.

Discussion. *Distictella arenaria* is most similar to *D. mansoana* and *D. chocoensis*. *Distictella mansoana* differs from *D. arenaria* in having narrow (3–7 × 1–1.5 mm), early caducous pseudostipules, leaflets with the tertiary veins usually raised on the adaxial surface, petioles usually longer than petiolules (vs. petiolules usually longer than petioles), capsule much thicker (1.2–2.5 cm diam.) with a prominent midrib, and seeds with wings well demarcated from seed body. *Distictella chocoensis* differs from *D. arenaria* in having the petioles longer than the petiolules, tertiary veins not branching, and ovaries without a stipe. The last character may not be reliable, as few flowering specimens of either species are available. Fruiting material of *D. chocoensis* is not known. *Distictella arenaria* is also separated by geography and habitat from *D. chocoensis*, which is endemic to the wet forests of Chocó and Valle del Cauca, Colombia, and by geography from *D. mansoana* of Brazil, Bolivia, and southern Peru.

Additional specimens examined. COLOMBIA. **Vaupés:** Río Piraparaná, environs of Catholic mission of San Miguel, Cañon Colorado, *E. W. Davis 140-a* (MO). **Vichada:** Parque Nac. Nat. El Tuparro, ca. 10 km SW of Centro Administrativo on rd. to El Tapón (due S of Cerro Peinilla), *J. L. Zarucchi & C. E. Barbosa 3437-a* (MO). VENEZUELA. **Amazonas:** Canaripo, lado sur del río Ventuari, *J. A. Steyermark & P. Redmond 112819* (MO); 18 km S of Samariapo toward Río Sipapo, *A. H. Gentry & P. Berry 14618* (MO); 0–3 km from Río Sipapo, 29–32 km S of Samariapo, *A. H. Gentry & P. Berry 14633* (MO); rd. from San Fernando de Atabapo to Santa Barbara, 12–40 km from San Fernando, *A. H. Gentry & S. Tillett 10874* (MO); Dpto. de Atures, Caño Morrococoy, vía Puerto Sipapo, *A. Castillo et al. 3502* (MO); Dpto. Atabapo, Cerro Huachamacarí, E slope, *R. Liesner 25720* (MO), *25767* (MO). **Bolívar:** Río Caura, arriba del Salto Para, en las islas 2–3 km arriba del camp, Las Pavas, *J. A. Steyermark et al. 113086* (MO).

2. *Distictella campinae* A. Samp., Ann. Acad. Brasil. Sci. 7: 120. 1935. TYPE: Brazil. Pará: near Vigia, 26 June 1926, as “21 June 1927,” *A. Ducke s.n. (RB 22688)* (holotype, RB!; isotype, MO!).

Low liana or scandent shrub to 1 m; young branchlets terete, drying dull yellowish brown or black, solid, lepidote, pubescent or glabrescent; trichomes colorless or ferruginous to ca. 0.5 mm; pseudostipules caducous, clavate, thick, 1–3 × 0.4–1 mm. Leaves bifoliolate, or sometimes first pair of leaves on branchlet unifoliolate, trifid tendril present (rarely residual to 1 mm long) or absent; petiole 4–12 mm, with trichomes like those of branchlets; petiolules (1)3–7 mm, with trichomes like those of branchlets; leaflets elliptic (rarely spatulate), 5.2–

11.5 × 1.6–5 cm, coriaceous, (7)8(9) pairs of lateral veins, each lateral vein initiating at a 70°–90° angle with the midrib and extending in a nearly straight line toward margin before looping to meet next lateral vein, strongly brochidodromous, tertiary veins inconspicuous, loosely open-reticulate, all veins immersed adaxially, midrib raised abaxially, and other veins immersed to flat (lateral veins sometimes slightly raised), both surfaces drying pale gray-green, adaxial surface without trichomes, abundantly lepidote, sometimes with scattered glands, abaxial surface without trichomes, abundantly lepidote, often with glandular fields at base and sometimes at apex or glands scattered, margin flat (rarely slightly revolute), base rounded, or cuneate and then rounded, apex acute. Inflorescence a raceme or racemose panicle, peduncle with rachis 3–13 cm with 5 to 11 flowers, peduncle 1–2.5 mm wide at base, peduncle, rachis, and pedicels drying dull yellowish brown or grayish brown, pubescent with trichomes like those of branchlets, bracteoles ca. 1.75 × 0.5 mm, usually lost before anthesis; calyx 7–10 × 8–9 mm, membranous or subcoriaceous, pubescent with minute red or colorless trichomes tightly appressed, glandular fields 1.5 to 2 pairs; corolla white, infundibular from cylindric base, curved 1/3–1/2 distance from base, 5.5–6.5 cm, membranous, tube 4–4.2 cm with cylindric base 10–11 mm long and mouth 13–18 mm wide, externally densely puberulent with minute trichomes above glabrous base, internally puberulent and lepidote, with villous clusters of trichomes at bases of stamens and staminode, lobes 15–20 × 15–23 mm; stamens and staminode inserted 9–11 mm from base of corolla tube, anthers 3–4.2 mm, longer filaments 18–19 mm, shorter filaments 15.5–17 mm, staminode 2–3 mm; disc 1–1.5 × ca. 3.5 mm; pistil 3.3–3.5 cm, ovary ca. 3 × 1.3–1.5 mm, stipe 0.5–2 mm, stigma lanceolate. Capsule elliptic, not curved, ca. 5 × 2.2 cm, ca. 0.4 cm diam., base acute, apex obtuse or truncate, valves compressed, drying brown, densely pubescent with minute, appressed, dull white trichomes, glands scattered, midrib not evident, wall ca. 2.2 mm thick. Seeds 7–8 × 11–12 mm, wings greatly reduced and poorly demarcated from seed body, reddish brown, subcoriaceous, opaque, the veins not contrasting in color to surface.

Distribution. *Distictella campinae* is known from the Brazilian states of Amazonas and Pará with one collection from Rondônia. It is often found growing in white sand savanna or campinas, between 50 and 100 m. Figure 1A.

Phenology. Flowering March, August, September, and December; fruiting March.

Discussion. Sandwith (1962) treated *Distictella campinae* as a synonym of *D. cuneifolia*. *Distictella campinae* is very similar to both *D. cuneifolia* and bifoliolate specimens of *D. laevis*. However, the lateral veins in the leaflets of *D. cuneifolia* and *D. laevis* are initiated at about a 45° angle before curving toward the apex and finally anastomosing with the higher order venation. They also differ markedly in the seeds; the wings are hyaline, well developed (seeds 9–14 × 25–28 mm), and well demarcated from the seed body in *D. cuneifolia* and *D. laevis*. *Distictella campinae* and *D. laevis* have similar geographic distributions and are found in similar habitats, but *D. cuneifolia* is endemic to Bolivia, where it is found in savannas or pampas with black silty soils, which are often described as seasonally inundated, or with numerous termite mounds.

Selected specimens examined. BRAZIL. **Amazonas:** Rio Uatumã, Mun. de Itapiranga, próximo à cachoeira do Tucumã, *C. A. Cid Ferreira et al.* 497 (MO). **Pará:** 10 km E of Portel, *G. T. Prance et al.* 1291 (MO); Mun. de Vigia, 36 km SE of Vigia, along hwy. PA-140 to Belém, *G. Davidse et al.* 17568 (MO). **Rondônia:** Mun. Costa Marques, BR-429, 123 km de Costa Marques, entrando 06 km num vicinal de margem esquerda, na Faz., Três Irmãos, *C. A. Cid Ferreira et al.* 8664 (MO).

3. *Distictella chocoensis* A. H. Gentry, *Phytologia* 47: 100. 1980. TYPE: Colombia. Chocó: ca. 10 km W of Istmo de San Pablo on PanAmerican Hwy., W of Las Animas, 110 m, 12 Jan. 1979, A. H. Gentry & E. Renteria A. 24089 (holotype, COL not seen; isotype, MO!).

Liana; young branchlets terete, sometimes flattened at nodes, drying dull brown or reddish brown, solid, lepidote, pilose with tangled, ferruginous trichomes, ca. 0.3 mm long or puberulent with erect or ascending, ferruginous trichomes, 0.05–0.3 mm; pseudostipules often present, oblong, thick, 4–7 × 2–4 mm. Leaves bifoliolate, trifid tendril sometimes present; petiole 25–60 mm, with pubescence like that of branchlets; petiolules 10–30 mm, with pubescence like that of branchlets; leaflets lanceolate, ovate, or elliptic, (6–)13–24 × (3.5–)7–14.4 cm, subcoriaceous to coriaceous, 5 or 6 pairs of lateral veins, each lateral vein initiating at a 45°–60° angle with the midrib and gradually curving upward toward margin, tertiary veins conspicuous, connecting midrib and lateral veins, higher order venation forming a medium to fine, closed network, all veins immersed adaxially and raised abaxially, adaxial surface drying brownish green, somewhat bullate in more coriaceous leaflets, midrib and often lateral veins and surface pubescent, inconspicuously but abundantly lepidote, with or without scattered glands, abaxial surface drying grayish green, pilose or with erect to spreading, white

trichomes, 0.2–0.3 mm, abundantly lepidote, often with fields of glands in the axils of most of the lateral veins with the midrib, margin flat, base cordate, subcordate, or rounded, apex acute or obtuse. Inflorescence a raceme or racemose panicle, peduncle with rachis 15–25 cm with 20 to 30 flowers, peduncle 3–5 mm wide at base, peduncle, rachis, and pedicels drying reddish brown with pubescence like that of branchlets, bracteoles absent or not seen; calyx (7–)10–12 × (7–)11–12 mm, coriaceous, with minute, appressed, ferruginous trichomes and densely lepidote, glandular fields 2 or 2.5 pairs; corolla white, infundibular from cylindrical base, curved 1/3 distance from base, 4–5 cm, subcoriaceous, tube 3–4 cm with cylindrical base 9–10 mm long and mouth 12–15 mm wide, externally and internally pubescent with minute trichomes above glabrous base and internally with clusters of glandular papillae or villous at bases of stamens and staminode, lobes (5–)10–12 × 8–14 mm; stamens and staminode inserted 6–8 mm from base of corolla tube, anthers ca. 4 mm, longer filaments 22–23 mm, shorter filaments 17–20 mm, staminode 5.5–7 mm; disc 1–2 × 4–5 mm; pistil ca. 3.6 cm, ovary (3–)4–4.5 × (1.5–)2.2–2.5 mm, stipe absent, stigma orbicular. Fruit unknown.

Distribution. *Distictella chocoensis* is endemic to the Chocó and Valle del Cauca departments of Colombia. It has been found in wet forests from sea level to 110 m elevation. Figure 2A.

Phenology. Flowering July, October, and December; fruiting material not known.

Discussion. *Distictella chocoensis* is most similar to *D. arenaria*. *Distictella arenaria* differs from *D. chocoensis* in having the petiolules longer than the petioles, tertiary veins branching, and the ovary on a stipe (see discussion of *D. arenaria*). *Distictella arenaria* is known from southern Venezuela and eastern Colombia, where it is usually found in white sand thickets, shrubby islands in savannas, and disturbed areas.

Additional specimens examined. COLOMBIA. **Chocó:** 50 m, *J. J. Triana 4124-10* (BM). **Valle del Cauca:** Bajo Calima, rd. to Juanchaco Palmeras, *A. H. Gentry et al. 47844* (MO), *47957* (MO); Bajo Calima, Concession of Carton de Colombia, near entrance to Dindo area, *A. H. Gentry et al. 53286* (MO); Bajo Calima, Concesión Pulpapel/Buenaventura, *M. Monsalve B. 1916* (MO).

4. *Distictella cremersii* A. H. Gentry, *Phytologia* 46: 209. 1980. TYPE: French Guiana. Haut Tampoc, le long des Criques pres de la Crique Alice, 1 Apr. 1977, *G. Cremers 4589* (holotype, MO!; isotype, CAY not seen).

Liana; young branchlets terete or flattened, drying reddish brown, hollow or solid, abundantly lepidote, sparsely pubescent; trichomes to ca. 0.03 mm; pseudostipules not seen. Leaves bifoliolate, trifid tendril sometimes present; petiole 15–17 mm, with trichomes like those of branchlets, or sometimes longer to 0.3 mm; petiolules 8–12 mm, with trichomes like those of branchlets, or sometimes longer to 0.3 mm; leaflets elliptic, 10.3–16 × 5–7.5 cm, chartaceous, 4 to 7 pairs of lateral veins, each lateral vein initiating at a 20°–45° angle with the midrib and curving toward the apex and fading, tertiary veins connecting lateral veins and midrib or to a lesser extent weakly anastomosing with higher order venation to form an open or loosely closed network, all veins immersed adaxially or all but midrib flat, midrib and lateral veins raised abaxially, and other veins immersed to flat, both surfaces drying olive-green or brownish green, adaxial surface without trichomes or midrib with minute appressed trichomes, scattered lepidote, glands not seen, abaxial surface with axils of lateral veins with midrib pilose, and some trichomes often along midrib, scattered lepidote, usually with scattered glands, margin flat, base cuneate, cuneate and then rounded, or inequilateral with one side acute and the other obtuse, apex acuminate or obtuse and then briefly acuminate, tip rounded and then apiculate. Capsule broadly elliptic or oblong, not curved, 7–11 × 4–5.5 cm, 3–4 cm diam., base acute and truncate, apex obtuse, valves strongly convex, drying greenish gold or golden brown, densely pubescent with minute, appressed, golden trichomes, midrib not evident, wall 4–5 mm thick. Seeds 14–16 × 12–20 mm, wings nearly totally reduced, poorly demarcated from seed body, reddish brown or reddish black, subcoriaceous, opaque, the veins not contrasting in color to surface.

Distribution. *Distictella cremersii* is known from Suriname, French Guiana, and Ilha de Marajó, Pará, Brazil. It is found in riparian vegetation; the elevation indicated on only one specimen is 25 m. This specimen (*R. Evans & G. Lewis 1869*) also described the habitat as a seasonally inundated, secondary, white sand forest. Figure 1A.

Phenology. Fruiting March and April. Flowering material not seen.

Discussion. Flowering material of *Distictella cremersii* is not known, but the fruit and vegetative material suggest a relationship with *D. racemosa*. The leaflets are similar to those of *D. racemosa* var. *translucida*: the lateral vein axils are pilose and there are no glandular fields at the leaflet apex or base. The fruits and seeds suggest *D. racemosa* var. *racemosa*,

except that the fruits of *D. racemosa* var. *racemosa* are relatively narrower and thinner (8–16 × 3.5–7 cm, 0.5–4.5 cm diam.) and often compressed and split along the midrib at maturity, and the seeds have a much larger wing (seeds 15–28 × 24–45 mm). Label information currently available suggests that *D. cremersii* is found in riparian vegetation (seasonally inundated forests on white sand), *D. racemosa* var. *racemosa* in seasonally inundated forests associated with black water, and *D. racemosa* var. *translucida* in forests that are not seasonally flooded.

Additional specimens examined. BRAZIL. **Pará:** Ilha de Marajó, rio Mucunas, afluyente do rio Anajás, em frente a cidade de Anajás, A. S. Tavares 358 (MO). FRENCH GUIANA. Rivière Camopi, en Amont du Saut Yaniwé, J.-J. de Granville 2080 (MO); Haute Approuague, crique Matarony, R. A. A. Oldeman B-997 (MO); Rivière Tampoc, saut Koumakou, Moretti 636 (MO). SURINAME. **Para:** Along rd. from Zanderij to Kraka, 4.9 km from intersection w/ Zanderij Hwy., 30 m before bridge over Sabakoe Creek, R. Evans & G. Lewis 1869 (MO).

5. *Distictella cuneifolia* (DC.) Sandwith, Kew Bull. 1953: 476. 1953 [1954]. Basionym: *Pithecoctenium cuneifolium* DC. in A. DC., Prodr. 9: 196. 1845. TYPE: Without country [Bolivia, cf. disc.]. "Para," s.d., s. coll., s.n. (holotype, P not seen, photo F neg. 39945!, photo K not seen; isotypes, G-DC fragm. not seen, microfiche G-DC 9.196.16!, G fragm. not seen).

Low liana or scandent shrub to 3 m; young branchlets terete, drying dull black or brown, solid, lepidote, pubescent; trichomes dull white, to ca. 0.06 mm; pseudostipules not seen. Leaves bifoliolate, trifid tendril often present; petiole 6–16 mm, with trichomes like those of branchlets; petiolules 4–10 mm, with trichomes like those of branchlets; leaflets narrowly spatulate, almost oblong, or rarely oblong or elliptic, 4.7–8(11) × 1.8–3.3(4) cm, coriaceous or subcoriaceous, 5 to 7 pairs of lateral veins, each lateral vein initiating at a 45°(60°) angle with the midrib and curving toward the apex, anastomosing with tertiary veins and weakly brochidodromous, tertiary veins inconspicuous, loosely open-reticulate, all veins immersed adaxially, midrib raised abaxially, and other veins immersed to flat (lateral veins sometimes slightly raised), both surfaces drying gray-green or brownish green, adaxial surface without trichomes or midrib with minute appressed trichomes, abundantly lepidote, usually with scattered glands, abaxial surface without trichomes, abundantly lepidote, usually with scattered glands, margin flat (rarely slightly revolute), base cuneate or cuneate and then rounded, apex rounded (rarely acute) and emarginated or apiculate. Inflorescence a raceme or

racemose panicle, peduncle with rachis 7–12.5 cm with 9 to 17 flowers, peduncle 2–4 mm wide at base, peduncle, rachis, and pedicels drying dull grayish green, pubescent with trichomes like those of branchlets, bracteoles absent or not seen; calyx 8–10 × 8–9 mm, coriaceous, pubescent with minute, white trichomes tightly appressed, glandular fields 2 pairs; corolla white, campanulate from cylindrical base, curved 1/5 distance from base, 5–8 cm, membranous, tube 3.8–6.5 cm with cylindrical base 9–13 mm long and mouth 20–29 mm wide, externally densely puberulent with minute trichomes above glabrous base, internally minutely puberulent, with villous clusters of trichomes at bases of stamens and staminode, lobes 10–15 × 15–20 mm; stamens and staminode inserted 8–9 mm from base of corolla tube, anthers ca. 5 mm, longer filaments 25–27 mm, shorter filaments 18–21 mm, staminode 5–7 mm; disc ca. 1 × 3–4 mm; pistil 3.8–4.7 cm, ovary 3–4 × 1.5–2 mm, stipe 0.3–1 mm, stigma lanceolate or subulate. Capsule weakly spatulate, nearly oblong, slightly curved, 6–6.7 × 2.5–2.7 cm, ca. 0.4–0.6 cm diam., base cuneate and truncate, apex obtuse and apiculate, one valve concave and one convex, drying red-brown, densely pubescent with minute, appressed, golden trichomes, midrib conspicuously prominent, wall 1.5–2 mm thick. Seeds 9–12 × 26–28 mm, wings well demarcated from seed body, light reddish brown or tan with tips dirty white, membranous, hyaline especially at tips, the veins contrasting in color to surface.

Distribution. *Distictella cuneifolia* is known from the Santa Cruz and Beni departments of Bolivia. It is often found growing in savannas or pampas with fine, black, silty soil, frequently described as seasonally inundated or as with numerous large termite mounds, between 100 and 400 m elevation. Figure 1A.

Phenology. Flowering January, February, and May; fruiting July and October.

Discussion. The only collection information on the type of *Pithecoctenium cuneifolium* is the word, or abbreviation, "Para." De Candolle (1845) and Sandwith (1953) assumed this to be the state of Pará in northeastern Brazil. I questioned this, given the currently known distribution of this taxon. A number of recent collections have been made along the Río Paraguá in the department of Santa Cruz, Bolivia, and I thought that the "Para." on the type specimen might be an abbreviated form for this river. Discussions with James Solomon and consultations with Goodman (1972) and Funk and Mori (1989) led me to conclude that the most likely person to have collected along this river prior to 1845 was A. D. d'Orbigny. However, while

Orbigny did travel in this general vicinity, I found no mention of the Río Paraguá in Orbigny (1846), and the type locality of *Distictella cuneifolia* remains dubious.

Distictella cuneifolia is most similar to *D. campinae* and bifoliolate specimens of *D. laevis*. Gentry, following Sandwith (1962), identified specimens of *D. campinae* as *D. cuneifolia*, which may cause confusion in the Tropicos database for specimens this author has not also studied. The most striking difference between *D. campinae* and *D. cuneifolia* is the lateral veins in the leaflets, which are initiated at nearly a right angle (70° – 90°) in *D. campinae* and extend in almost a straight line to the margin before looping up to meet the next lateral vein. They also differ markedly in the seeds; the wings are opaque, greatly reduced, and poorly demarcated from the seed body in *D. campinae*. *Distictella laevis* is most dissimilar to *D. cuneifolia* in its very short petioles (1–4 mm) and short to absent (to 1 or rarely 2 mm) petiolules. It also appears to never develop tendrils, which are very common in *D. cuneifolia*. From the limited material observed it also seems that *D. laevis* has smaller corollas (4.5–5.5 cm) than *D. cuneifolia*. Both *D. campinae* and *D. laevis* differ from *D. cuneifolia* in habitat; they are found in white sand savannas or campinas.

Selected specimens examined. BOLIVIA. **Beni:** Prov. Gral. Ballivián, Riberalta, 160 km hacia Santa Rosa, S. G. Beck 20589 (MO). **Santa Cruz:** Velasco, camp. El Refugio a 10 km al E de la casa, yendo hacia la serranía Caparuch, Puesto Pasto, R. Guillén & S. Coria 2111 (MO); Velasco Prov., Reserva Ecológica El Refugio, 1500 m al SE hacia la junta del río Paraguá y Tarvo, R. Guillén & V. Roca 3092 (MO); Velasco, Parque Noel Kempff M. camp. La Torre, R. Quevedo et al. 2611 (MO).

6. *Distictella dasytricha* Sandwith, Kew Bull. 1953: 476. 1953 [1954]. TYPE: Brazil. Goiás: Mun. Yataí (Jataí), Queixada, 8 July 1949, A. Macêdo 1906 (holotype, K!; isotype, G!, MO!, US not seen, digitized image!).

Liana; young branchlets terete, drying dull black or golden brown, hollow (rarely solid), pubescent with spreading trichomes; trichomes golden, the longest 1–2 mm; pseudostipules occasionally present, oblong to falcate, thick, $4\text{--}5 \times \text{ca. } 1$ mm. Leaves bifoliolate, trifid tendril occasionally present; petiole 10–20 mm, with pubescence like that of branchlets; petiolules 7–20 mm, with pubescence like that of branchlets; leaflets oblanceolate to obovate, $9\text{--}15.5 \times 5.5\text{--}9.9$ cm, subcoriaceous to coriaceous, 4 or 5(6 or 7) pairs of lateral veins, each lateral vein initiating at a 20° angle with the midrib and extending toward apex before curving and fading, tertiary veins conspicuous, connecting midrib and lateral veins, the higher order venation strongly reticulate and forming a fine, closed

network, all veins immersed adaxially and raised abaxially, both surfaces drying brownish green, adaxial surface with golden, erect trichomes 0.6–1.9 mm, dense to scattered on main veins and scattered on surface, abundantly lepidote, with or without scattered glands, abaxial surface with dense, golden trichomes 0.6–1.1 mm, erect to spreading, or pilose, abundantly lepidote, without visible glands, margin flat, base cuneate, apex rounded and cuspidate or emarginate, or obtuse. Inflorescence a raceme or racemose panicle, peduncle with rachis 3–36 cm with 4 to 18 flowers, peduncle 2–4.5 mm wide at base, peduncle, rachis, and pedicels drying brown or golden brown, pubescent with trichomes like branchlets, bracteoles ca. 6.5×2 mm, lost before anthesis; calyx $8\text{--}13 \times 10\text{--}12$ mm, subcoriaceous, pubescent with dense golden trichomes to 1 mm, erect to ascending, glandular fields 2 pairs; corolla white with yellow throat, infundibular from cylindrical base, curved 1/4 distance from base, 5–7 cm, chartaceous, tube 3–6 cm with cylindrical base 10–15 mm long and mouth 15–25 mm wide, externally and internally densely pubescent with minute trichomes above glabrous base, internally with villous clusters of trichomes at bases of stamens and staminode, lobes $10\text{--}17 \times 15\text{--}25$ mm; stamens and staminode inserted 10–15 mm from base of corolla tube, anthers 4.5–5 mm, longer filaments 20–25 mm, shorter filaments 16–22 mm, staminode ca. 6 mm; disc ca. 2×4 mm; pistil ca. 4.1 cm, ovary $4\text{--}5 \times 2\text{--}2.5$ mm, stipe ca. 1 mm, stigma subulate. Capsule elliptic-oblong, curved, $6.8\text{--}7.5 \times 3\text{--}3.5$ cm, 0.8–1 cm diam., base obtuse, apex obtuse to rounded, one valve concave and the other convex, subvelutinous with minute, golden trichomes, somewhat warty, especially at base, midrib prominent, wall 1–1.5 mm thick. Seeds $13\text{--}15 \times 27\text{--}35$ mm, wings poorly demarcated from seed body, golden brown, membranous, hyaline only at tips, the veins not contrasting in color to the surface.

Distribution. *Distictella dasytricha* is known from Brazil (Goiás and Acre) and Peru (Loreto). It is reportedly found in swampy forested areas at 240 m elevation. Figure 2A.

Phenology. Flowering July and November; fruiting October.

Discussion. Gentry identified numerous sterile collections throughout the Amazon (in Colombia, Peru, Bolivia, and Venezuela) as *Distictella* aff. *dasytricha*, and included *D. dasytricha* in his unpublished treatment of Bignoniaceae for the *Flora of Colombia* based on one of these collections (A. H. Gentry et al. 9087, MO) and in the *Flora of the Venezuelan Guayana* (Gentry, 1997), based on R.

Liesner & B. Holst 21319 (MO). These sterile collections differ from the known fertile collections (and are not included in the concept of *D. dasytricha* employed here) in having much larger, membranous leaflets, which are much less pubescent, with the higher order venation not or only slightly raised abaxially but slightly raised adaxially, and forming a very loose network. The leaflet apices also tend to be very long attenuate. Gentry (1997) suggested that the Venezuelan collection, in addition to several Peruvian collections, might be specifically distinct from true *D. dasytricha*.

Distictella dasytricha is similar to *D. reticulata* in its venation (four or five pairs of lateral veins initiating at a 20° angle with midrib, higher order venation strongly reticulate, forming a very fine, closed network, all venation immersed adaxially and raised abaxially), but *D. reticulata* has smaller trichomes (to ca. 0.4 mm long) and capsules not curved and without a prominent midrib. The only species of *Distictella* with trichomes of similar length to those of *D. dasytricha* is *D. porphyrotricha*. *Distictella porphyrotricha* differs from *D. dasytricha* most markedly in its bullate leaflets with much looser venation reticulation. It also has lateral veins diverging from the midrib at a wider angle (45°), trichomes ferruginous, red, or white, inflorescence with persistent bracteoles, and a capsule that is longer (ca. 12 cm), not curved, with an acuminate apex, and without a prominent midrib, and is found at higher elevations (900–1380 m) in terra firme forests.

Additional specimens examined. BRAZIL. **Acre:** Proj. RADAM, sub-base de Cruzeiro do Sul, divisa Brasil-Peru, ponto 01-SC-18-XA, *L. R. Marinho 340* (MO). **Goiás:** Mun. Yataí (Jataí), Queixada, 28 Oct. 1950, *A. Macêdo 1906 [a]* (K). PERU. **Loreto:** Prov. Alto Amazonas, Capihuari, 5 km NE of Andoas on Río Capihuari, near Ecuador border along oil pipeline, *A. H. Gentry & C. Díaz S. 28225* (MO), *28234* (MO).

7. *Distictella elongata* (Vahl) Urb., *Repert. Spec. Nov. Regni Veg.* 14: 310. 1916. Basionym: *Bignonia elongata* Vahl, *Eclog. Amer.* 2: 45, t. 16. 1798. *Pithecoctenium elongatum* (Vahl) Klotzsch in M. R. Schomb., *Reis. Br.-Guiana* 3: 1158. 1848 [1849]. *Distictis elongata* (Vahl) Bureau ex Benth. in Benth. & Hook. f., *Gen. Pl.* 2: 1038. 1876. TYPE: French Guiana. Cayenne, s.d., *J. P. B. von Rohr 2001* (lectotype, designated by Gentry, 1982: 174, C!, photo F neg. 22130!).

Pithecoctenium obovatum Mart. ex DC. in A. DC., *Prodr.* 9: 196. 1845. TYPE: French Guiana. s. loc., s.d., *J. Martin s.n.* (holotype, BR "Herb. Martius" not seen, digitized image!; isotype, P not seen).

Liana; young branchlets terete, flattened at nodes, drying dull brown, usually hollow, densely lepidote,

densely tomentose or with the trichomes erect then weakly curving or ascending; trichomes tan, 0.1–0.3 mm; pseudostipules rarely present, obovate, ca. 5 × 3.5 mm. Leaves bifoliolate, trifid tendril sometimes present; petiole 5–22 mm, with pubescence like that of branchlets; petiolules 5–11 mm, with pubescence like that of branchlets; leaflets irregularly obovate, 6.5–13.7 × 3.5–8.2 cm, chartaceous to subcoriaceous, 3 to 5 pairs of lateral veins, each lateral vein initiating at a 20° angle with the midrib and extending toward apex before curving and anastomosing with tertiary veins, tertiary veins conspicuous, generally closely spaced and connecting midrib and lateral veins, to lesser extent anastomosing with higher order venation, which form a fine, closed network, all veins immersed adaxially and raised abaxially, adaxial surface drying brownish yellow-green, without trichomes except for midrib and apex and sometimes lateral veins, abundantly lepidote, with or without scattered glands, abaxial surface drying grayish yellow-green, densely tomentose with white, often translucent, trichomes to 0.1 mm long and tangled, abundantly lepidote, usually with fields of glands in the axils of most of the lateral veins with the midrib (rarely absent), margin flat, base shortly attenuate or cuneate, apex obtuse, rounded, or obtuse and cuspidate. Inflorescence a racemose panicle (perhaps rarely raceme), peduncle with rachis 25–40 cm with 20 to 25 flowers, peduncle 3–4 mm wide at base, peduncle, rachis, and pedicels drying dull brown, pubescent with trichomes like branchlets, bracteoles ca. 4 × 1 mm, lost before anthesis; calyx 10–12 × 10–11 mm, coriaceous, pubescent with trichomes tan to ferruginous, like those of branchlets, and lepidote, glandular fields 2 pairs; corolla white with yellow throat, infundibular from cylindrical base, curved 1/3 distance from base, (4–)5.5–7.2 cm, chartaceous, tube 4.5–5.2 cm long with cylindrical base 9–11 mm long and mouth 19–20 mm wide, externally and internally pubescent with minute trichomes above glabrous base, internally with clusters of glandular papillae (rarely villous) at bases of stamens and staminode, lobes 10–20 × 15–20 mm; stamens and staminode inserted 10–12 mm from base of corolla tube, anthers ca. 4 mm, longer filaments 22–25 mm, shorter filaments 20–21 mm, staminode ca. 6 mm; disc 1–1.5 × ca. 4 mm; pistil 3.9–4.7 cm, ovary 4–5 × ca. 2 mm, stipe absent to 1 mm, stigma lanceolate. Capsule elliptic, curved, ca. 8 × 2.8 cm, ca. 1 cm diam., base acute and truncate, apex acuminate, one valve concave and the other convex, drying golden-brown, densely pubescent with trichomes like those of branchlets, slightly warty, midrib prominent, wall ca. 1.25 mm thick. Seeds 8–10 × 25–28 mm, wings poorly demarcated from seed body, reddish brown with tips lighter brown, membranous, hyaline, the veins contrasting in color to surface.

Distribution. *Distictella elongata* is known from French Guiana, Suriname, and Pará, Brazil, with one slightly atypical collection from Amazonas, Brazil, and another from Rondônia, Brazil. It is found in secondary forests frequently characterized as growing on white sand and as being on terra firme, at elevations ranging from sea level to 200 m. Figure 2A.

Phenology. Flowering January, February, June, and December; fruiting June.

Discussion. *Pithecoctenium obovatum* is placed in synonymy of *Distictella elongata* based on observation of the digitized image of the holotype (barcode BR 880344) and following the synonymy of Sandwith (1937, 1938a).

Gentry's concept of the species *Distictella elongata* is very different from that employed here. His identification of herbarium specimens indicates a very broad concept. Gentry identified as *D. elongata* specimens that are treated here as three different species, *D. elongata*, *D. mansoana*, and *D. parkeri*. The general distribution range that he cited for *D. elongata* (1982, 1997) reflects this usage and in the *Flora de Venezuela* (1982), Gentry listed *D. mansoana* in synonymy below *D. elongata*. However, Gentry's descriptions and keys in the *Flora de Venezuela* (1982) and *Flora of the Venezuelan Guayana* (1997) appear to be based on specimens of *D. parkeri*. *Distictella parkeri* differs from *D. elongata* most markedly in its leaflets, which have a rounded to cordate base, tertiary veins immersed or flat on the abaxial surface, and lateral veins forming a wider angle (45°) to the midrib. In addition, the midrib of the fruit of *D. parkeri* is not at all prominent. The two species are found in similar habitats and have overlapping ranges of distribution. *Distictella mansoana* differs from *D. elongata* in generally having leaflets with bases usually rounded to subcordate, and the tertiary veins usually raised on the adaxial surface and anastomosing with the higher order venation to form a very loose network. The fruits of *D. mansoana* are somewhat larger (9.5–16 cm long), glandular, and warty, and the seeds are much larger (13–20 × 32–55 mm) with well-demarcated wings. Lohmann and Pirani (1998) and Lohmann and Hopkins (1999) used the name *D. elongata* for *D. mansoana*, following Gentry's (1982) synonymy and specimen identifications. The range of *D. mansoana* is generally to the south of *D. elongata* in Brazil, Bolivia, and Peru, and it is usually found at higher elevations.

Distictella elongata is similar to *D. dasytricha* in overall leaflet shape and venation, but the latter has much longer trichomes on the branchlets, petioles, petiolules, and inflorescence (the longest 1–2 mm) and capsules with the apex obtuse to rounded. Small-leaved

specimens of *D. elongata* are sometimes identified as *D. obovata*, but the latter has coriaceous leaflets with a recurved margin and lateral veins at a wider angle (45°) with the midrib, flowers in a raceme, and the fruit dull black without a prominent midrib. *Distictella obovata* is found at higher elevations (450–1660 m) and appears to be restricted to the Pakaraima Mountains of Guyana and adjacent areas of Bolívar, Venezuela.

Selected specimens examined. BRAZIL. **Amazonas:** Rio Aripuanã, ramal entre Transamazônica e Prainha, *N. T. Silva* 4356 (MO). **Pará:** Mun. Oriximiná, rio Trombetas, cachoeira Porteira, *C. A. Cid Ferreira et al.* 1264 (MO), *N. T. Silva & M. R. Santos* 4703 (MO); Mun. de Oriximiná, campos do Ariramba, Rio Jaramacarú, *G. Martinelli* 6850 (MO). **Rondônia:** Vilhena, rio Piracolina, *M. G. Silva & C. Rosario* 4917 (MO). FRENCH GUIANA. Rte. RN2 Cayenne–Regina, pk 36, *F. Billiet & B. Jadin* 5762 (BR); Savane Renner–Région littorale, *G. Cremers & J.-J. de Granville* 14427 (MO); Kourou, center spatial, *C. Feuillet* 1588 (MO). SURINAME. Betw. Tawajari-weg & de Crane-weg, W of Lelydorp, *N. M. Heyde* 591 (MO).

8. *Distictella laevis* (Sandwith) A. H. Gentry, Mem. New York Bot. Gard. 29: 274. 1978. Basionym: *Distictella monophylla* var. *laevis* Sandwith, Mem. New York Bot. Gard. 9: 362. 1957. TYPE: Venezuela. Amazonas: Cerro Yapacana, Río Orinoco, 100 m, 7 Jan. 1951, *B. Maguire, R. S. Cowan & J. Wurdack* 30788 (holotype, NY not seen, microfiche 947.A8!, digitized image!).

Shrub; erect or semi-scandent, 0.5–3 m; young branchlets terete (rarely flattened at nodes), drying dull brown or black, solid, sometimes lepidote, puberulent or glabrescent; trichomes colorless or ferruginous, less than 0.1 mm; pseudostipules caducous, clavate, thick, 2–4 × 0.7–1.2 mm. Leaves unifoliolate or bifoliolate, bifoliolate leaves with terminal scar, gland, or residual tendril ca. 1 mm; petiole 1–4 mm, puberulent with trichomes like those of branchlets; petiolules absent to 1(–2) mm, puberulent with trichomes like those of branchlets; leaflets oblong, or sometimes in bifoliolate leaves, oblanceolate to spatulate, 4.2–12 × 1.3–8.3 cm, coriaceous, 4 to 7 pairs of lateral veins initiating at a 45° angle with the midrib and curving upward toward margin, anastomosing with tertiary veins or weakly brochidodromous, tertiary veins inconspicuous, loosely open-reticulate, all veins immersed adaxially, midrib raised abaxially, and other veins immersed to flat (lateral veins sometimes slightly raised in older leaves), both surfaces drying grayish or yellowish green, adaxial surface sometimes glossy, without trichomes or puberulent at base of midrib, usually scattered lepidote, sometimes with scattered glands, abaxial surface puberulent at base of midrib or without trichomes, scattered lepidote, often with glandular

fields at base and sometimes at apex or glands scattered, margin flat (rarely slightly revolute), base rounded, subcordate, or cuneate and rounded, apex rounded or obtuse, often with small mucro or sometimes emarginate. Inflorescence a raceme, or rarely with lowest pedicels branching, peduncle with rachis 2.5–9 cm with 6 to 16 flowers, peduncle 2–3 mm wide at base, peduncle, rachis, and pedicels drying dull reddish or grayish brown, puberulent with trichomes like those of branchlets, bracteoles 1–7 × 0.5–4 mm, early caducous; calyx 5–6 × 5–8 mm, membranous, puberulent with minute red or colorless trichomes, glandular fields 1 to 5 pairs; corolla white, sometimes with yellow lobes and throat, infundibular from cylindric base, curved 1/3 distance from base, 4.5–5.5 cm, membranous, tube 3.2–4.5 cm with cylindric base 6–9 mm long and mouth 12–20 mm wide, externally and internally densely puberulent with minute trichomes above glabrous base, internally with villous clusters of trichomes at bases of stamens and staminode, lobes 8–15 × 9–15 mm; stamens and staminode inserted 8–10 mm from base of corolla tube, anthers 3–5 mm, longer filaments 18–20 mm, shorter filaments 12–17 mm, staminode 2.2–5 mm; disc 1–2 × 1.5–4 mm; pistil 2.9–3.3 cm, ovary 3–4 × 1–2 mm, stipe 0.5–2 mm, stigma ovate. Capsule oblong, not curved, 5–6.3 × ca. 2.5 cm, ca. 0.3 cm thick, base rounded, apex obtuse, valves compressed, drying brown, densely puberulent with minute white or golden trichomes, glands scattered, often granular, midrib not evident to subevidently raised, wall 1–2 mm thick. Seeds 10–14 × 25–28 mm, wings well demarcated from seed body, reddish brown with tips yellowish tan, membranous, hyaline, especially at tips, the veins contrasting in color to surface.

Distribution. *Distictella laevis* is known from Venezuela (Amazonas, the type) and Brazil (Pará and Amazonas). It is often found growing in open campina in white sandy soil, below 400 m elevation. Figure 1A.

Phenology. Flowering January, February, April, June, and September; fruiting February, May, and September.

Discussion. Unifoliolate specimens of *Distictella laevis* are similar to *D. monophylla*, which differs primarily in the abaxial surface of the leaflets, which is pubescent with all venation raised and higher venation forming a fine, closed network. One specimen (*O. Huber et al.* 3771) was seen that seemed to be intermediate between *D. laevis* and *D. monophylla*.

Bifoliolate specimens of *Distictella laevis* are similar to both *D. campinae* and *D. cuneifolia*. The most striking difference between *D. campinae* and *D.*

laevis is the lateral veins in the leaflets of *D. campinae*, which are initiated at nearly a right angle (70°–90°) to the midrib and extend in almost a straight line to the margin before looping up to meet the next lateral vein. They also differ markedly in the seeds; the wings are opaque, greatly reduced, and poorly demarcated in *D. campinae*. *Distictella cuneifolia* differs from *D. laevis* in habitat (black silty soils vs. white sand), geography (endemic to Bolivia), longer petioles (6–16 mm) and petiolules (4–10 mm), larger corollas (5–8 cm long), and the presence of leaf tendrils.

Selected specimens examined. BRAZIL. Amazonas: Transamazônica–Trecho Humaitá–Itaituba, Km 135 de Humaitá, perto de Km 895 da Transamazônica, *G. Vieira et al.* 108 (MO); Transamazon Hwy., 53 km W of Aripuanã River, *C. E. Calderón et al.* 2703 (MO). Pará: Serra do Cachimbo, Sul de Estado, *M. Alvarenga s.n.* (INPA 120328) (MO); Region of Missão Velha, a Mundurukú village, ca. 2 km N of Rio Cururú, *W. R. Anderson* 10928 (MO); Missão Cururú, *N. A. Rosa & M. R. Santos* 1862 (MO).

9. *Distictella lohmanniae* A. Pool, sp. nov. TYPE: Brazil. Amazonas: Reserva Florestal Ducke, Manaus–Itacoatiara, Km 26, 20 m, 2°53'S, 59°58'W, 14 July 1995, *L. G. Lohmann & C. F. da Silva* 20 (holotype, MO!; isotype, INPA not seen). Figure 3A–C.

Haec species *Distictellae parkeri* affinis, sed ab ea foliolis discoloribus subtus trichomatibus minutis appressis vestitis, nervis lateralibus angulum ca. 20° cum costa formantibus, nervis tertiariis plerumque parallelis approximatis non ramificantibus, capsula parum curva costa prominenti et seminibus alis a corpore bene distinctis praeditis distinguitur.

Liana; young branchlets terete, flattened at nodes, drying grayish green to dull brown, solid, lepidote, densely pubescent; trichomes white or ferruginous, to 0.03 mm long, tightly appressed; pseudostipules rarely present, elliptic, thick, ca. 3 × 1 mm. Leaves bifoliolate, trifid tendril sometimes present; petiole 6–20 mm, with pubescence like that of branchlets; petiolules 10–31 mm, with pubescence like that of branchlets; leaflets ovate-oblong or obovate-oblong, 8–15.3 × 4.2–9.3 cm, subcoriaceous, 4 to 6 pairs of lateral veins, each lateral vein initiating at a 20° angle with the midrib (except sometimes the basal) and extending toward apex, anastomosing with tertiary veins and fading, tertiary veins fairly conspicuous, connecting midrib and lateral veins, higher order venation loosely open-reticulate, midrib and lateral veins immersed and tertiary veins slightly raised to slightly immersed adaxially, midrib and lateral veins raised abaxially, tertiary veins immersed, adaxial surface drying dark blackish green, without trichomes, abundantly lepidote, without glands, abaxial surface

drying grayish yellow-green, densely covered with minute appressed trichomes like those of branchlets, not noticeably lepidote, usually with a few glands in the axils of basal lateral veins with the midrib, margin flat, base rounded or cuneate, apex rounded or obtuse and apiculate to cuspidate. Inflorescence a racemose panicle, peduncle with rachis 6–11 cm with 10 to 15 flowers, peduncle 4–6 mm wide at base, peduncle, rachis, and pedicels drying dull brown, pubescent with trichomes like branchlets, bracteoles ca. 2.5×1 mm, lost early; calyx ca. 10×10 –11 mm, coriaceous, pubescent with minute, ferruginous, appressed trichomes and lepidote, glandular fields 2.5 pairs; corolla white with yellow throat, infundibular from cylindrical base, curved 1/4 distance from base, 5–7 cm, subcoriaceous, tube 4–5.2 cm with cylindrical base 9–10 mm long and mouth ca. 20 mm wide, externally densely pubescent with minute trichomes above glabrous base, internally densely lepidote with a few minute appressed trichomes and villous clusters of trichomes at bases of stamens and staminode, lobes 10–20 \times 10–20 mm; stamens and staminode inserted 8–9 mm from base of corolla tube, anthers ca. 4 mm long, longer filaments 22–29 mm, shorter filaments 19–24 mm, staminode ca. 5 mm; disc ca. 1.5×3 mm; pistil ca. 4.5 cm, ovary ca. 5×2 mm, stipe apparently absent, stigma lanceolate. Capsule elliptic, slightly curved, ca. 9×4 cm, ca. 1.5 cm diam., base acute and truncate, apex acute, one valve slightly concave and the other slightly convex, both somewhat compressed, drying blackish green, densely pubescent with minute, appressed, ferruginous trichomes, somewhat glandular and warty, midrib prominent, capsule splitting along midrib at maturity, wall ca. 4 mm thick. Seeds 14–15 \times 40–48 mm, wings well demarcated from seed body, reddish brown with a halo of much lighter brown immediately around body and at wing tips, membranous, hyaline, the veins contrasting in color to surface (Figure: Lohmann & Hopkins, 1999: 620 as *Distictella parkeri*).

Distribution. *Distictella lohmanniae* is known from Amazonas, Brazil, where it is found in terra firme forests between 50 and 250 m elevation. Figure 2A.

Phenology. Flowering November and December; fruiting July.

IUCN Red List category. *Distictella lohmanniae* is currently known from seven collections. The data are deficient (DD) to determine IUCN Red List status. It is probably not Critically Endangered (CR), as its extent of occurrence is estimated to be more than

100 km² and its area of occupancy is estimated to be more than 10 km² (IUCN, 2001).

Discussion. At least one specimen of *Distictella lohmanniae*, A. H. Gentry 12976, was determined by Gentry and distributed to NY as the unpublished name *D. subincanum* A. H. Gentry. Most of the specimens cited as *D. lohmanniae* were previously determined by A. H. Gentry as *D. parkeri*, and Lohmann and Hopkins (1999) treated this taxon under that name in their treatment of Bignoniaceae for the *Flora da Reserva Ducke*. The species is named for Lúcia Lohmann, who collected the type specimen and helped me to recognize *D. lohmanniae* as distinct from similar species.

Distictella lohmanniae can be recognized from the other species of *Distictella* by its minute and strongly appressed foliar trichomes, similar to those of *Distictis pulverulenta*. It is most similar to *Distictella parkeri*, which has leaflets drying the same color on both surfaces with lateral veins at a 45° angle and tertiary veins generally branching, and the abaxial surface tomentose with trichomes to 0.15 or 0.2 mm long, longer inflorescences (peduncle with rachis 15–35 cm), more strongly curving fruits with the midrib not at all evident to subevident, and seeds with the wings poorly demarcated. *Distictella parkeri* is found farther north than *D. lohmanniae*, in the Guianas, Bolívar, Venezuela, and Amapá, Brazil, often in disturbed, white sand forests.

Additional specimens examined. BRAZIL. Amazonas: BR 319, Km 60, Manaus–Porto Velho Rd., betw. Rios Castanho & Araça, G. T. Prance et al. 23051 (MO); Manaus–Igarapé Leão Rd., 5 km from Manaus–Caracarai Rd., G. T. Prance et al. 11414 (MO); Km 130, Manaus–Caracarai Rd. (BR 174), A. H. Gentry 12976 (MO); Carauari, Poço Juruá, A. S. L. da Silva et al. 547 (MO); Distr. Agropecuario, Res. 1501-Km 41 do Smithsonian/INPA, Proj. Din. Biol. dos Frang. Floretais, M. A. Freitas et al. 469 (MO); Res. Fl. Ducke, Manaus–Itacoatiara, Km 26, INPA Overseas Development Admin., s. coll. 3994-24 (MO).

10. *Distictella magnoliifolia* (Kunth) Sandwith, Lilloa 3: 460. 1938. Basionym: *Bignonia magnoliifolia* Kunth in Humb., Bonpl. & Kunth, Nov. Gen. Sp. (quarto ed.) 3: 136. 1818 [1819], as “*magnoliaefolia*.” TYPE: Venezuela. Javita, ad ripam fluminum Tuamini et Temi (Misiones del Orinoco), A. Bonpland 973 (lectotype, designated by Sandwith, 1938b: 460, P not seen, F neg. 39415!).

Distictis kochii Pilg. in Koch-Grünberg, Zwei Jahre unter Indianern 2: 372. 1910. *Distictella kochii* (Pilg.) Urb., Repert. Spec. Nov. Regni Veg. 14: 310. 1916. TYPE: Brazil. Hylaea, Rio Aiary, Maloka, Dec. 1903, T. Koch-Grünberg 74 (holotype, B presumed destroyed, K photo!).

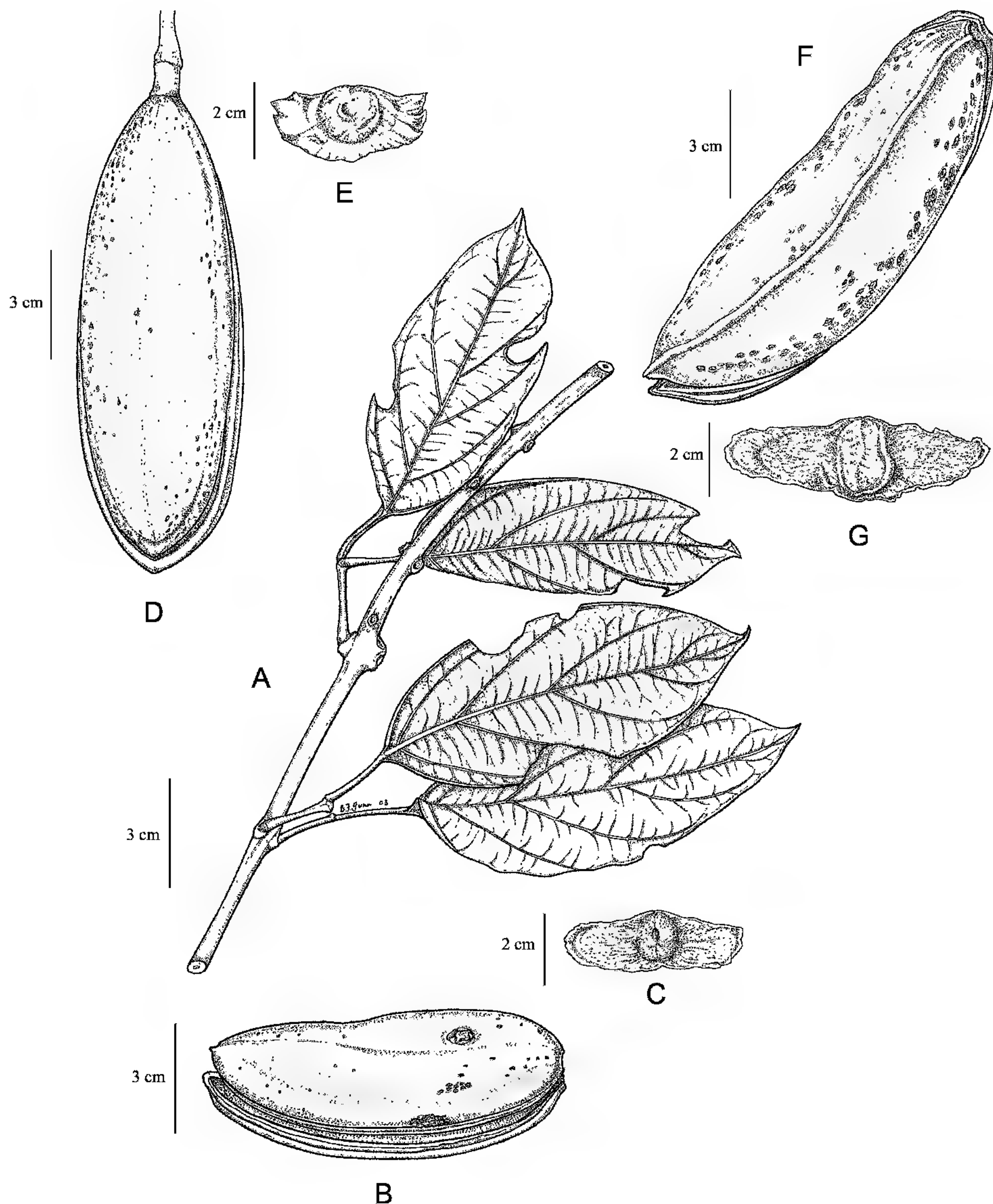

Figure 3. A–C. *Distictella lohmanniae* A. Pool. —A. Branchlet. —B. Fruit. —C. Seed (A, B, C from L. G. Lohmann & C. F. da Silva 20, MO). D, E. *Distictella racemosa* (Bureau & K. Schum.) Urb. var. *racemosa*. —D. Fruit. —E. Seed (D, E from G. T. Prance et al. 3366, MO). F, G. *Distictella racemosa* var. *translucida* A. Pool. —F. Fruit. —G. Seed (F, G from S. Hoyos & J. Hernandez 535, MO).

Liana; young branchlets terete, the nodes often flattened, drying dull black or brown, solid, densely lepidote, without trichomes or with few trichomes appressed at nodes; trichomes ferruginous, minute; pseudostipules rarely present, linear, thick, ca. 8×1 –1.5 mm. Leaves bifoliate, trifid tendril often present; petiole 25–55 mm, without trichomes or nearly so, densely lepidote; petiolules 12–40 mm, without trichomes or nearly so, densely lepidote; leaflets ovate or elliptic, often broadly so, 8 – $24 \times$

4.5–12.5 cm, coriaceous, 2 to 4 pairs of lateral veins, each lateral vein (above basal) initiating at a 45° angle with the midrib and curving toward the apex, anastomosing with tertiary veins and fading, tertiary veins connecting midrib and lateral veins and weakly reticulate with higher order venation forming a loosely closed network, all veins raised adaxially or midrib and lateral veins flat to immersed, all raised abaxially, both surfaces drying yellow-green or brownish green, adaxial surface without trichomes or base of midrib

with minute appressed trichomes, abundantly lepidote, sometimes with scattered glands and glandular fields at apex and in the axils of the basal lateral veins with the midrib, abaxial surface without trichomes, abundantly lepidote, usually with glandular fields at apex and in the axils of the basal lateral veins with the midrib, sometimes with scattered glands, margin slightly recurved, base rounded or subcordate, apex acute, obtuse, or rounded and cuspidate. Inflorescence a racemose panicle, peduncle with rachis 12–32 cm with 10 to 40 flowers, peduncle 2–4 mm wide at base, peduncle, rachis, and pedicels drying black or brown, pubescent with minute ferruginous, or white, appressed trichomes, bracteoles absent or not seen; calyx 7–10 × 7–12 mm, coriaceous, pubescent with minute, ferruginous, appressed trichomes, glandular fields 1 to 2.5 pairs; corolla white with yellow throat, infundibular from cylindric base, curved 1/3 distance from base, 5.5–6.3 cm, coriaceous, tube 3.5–5 cm with cylindric base 8–12 mm long and mouth 16–22 mm wide, externally and internally densely pubescent with minute trichomes above glabrous base, internally with villous clusters of trichomes at bases of stamens and staminode, lobes 12–16 × 12–20 mm; stamens and staminode inserted 8–10 mm from base of corolla tube, anthers 3–4 mm, longer filaments 21–25 mm, shorter filaments 17–20 mm, staminode 4–7 mm; disc 1–1.5 × 4–5 mm; pistil 3.3–4.1 cm, ovary 4–5 × 2–2.5 mm, stipe 0.5–1 mm, stigma subulate. Capsule narrowly oblong, slightly curved, 8–13.5 × 2–2.5 cm, 0.5–1.2 cm diam., base acute and truncate, apex very long attenuate, with one valve slightly concave and one slightly convex, drying black, densely lepidote with few scattered, minute, ferruginous trichomes, numerous glands present, granular and wrinkled, midrib subevident, wall 1–2 mm thick. Seeds ca. 12–15 × 42–50 mm, wings poorly demarcated from seed body, light brown with tips dirty white, membranous, hyaline especially at tips, the veins not contrasting in color to surface.

Distribution. *Distictella magnoliifolia* is known from Colombia (Vaupés and Guainía), Brazil (Amazonas), and Venezuela (Amazonas). It is usually found in scrubby or low forest, or savanna, on white sand, between 75 and 150(300) m elevation. Figure 1B.

Phenology. Flowering February, April, May, July, September, November, and December; fruiting July and December.

Discussion. Sandwith (1938b) selected *A. Bonpland* 973 (P) as the lectotype of *Bignonia magnoliifolia* Kunth. This specimen was not seen in this study, but a photo, F neg. 39415, of a P specimen labeled

“*Distictis magnoliaefolia* Bur.; *Bignonia magnoliaefolia* Bonpl.; Echantillon del herbier Bonpland” was studied. While the photo is not labeled with the collection number, Sandwith (1953: 478) cites that this is a photo of the type.

Distictis kochii is placed in synonymy of *Distictella magnoliifolia*, based on examination of the digitized image of the photo at K of *T. Koch-Grünberg* 74 (B), a synonymy previously proposed by Sandwith (1953).

The concept of *Distictella magnoliifolia* employed here is narrower than that used by Gentry in his various publications (Gentry, 1973, 1977, 1982, 1997) and that used by Burger and Gentry (2000), but follows Sandwith (1953). The illustration labeled *D. magnoliifolia* in Gentry (1973, 1977, 1982) depicts the flowering branch of *F. Woytkowski* 5140 and capsule of *B. A. Krukoff* 6728, both treated here as *D. racemosa* var. *racemosa*. The descriptions for the most part also pertain to that taxon except for some of the vegetative characteristics, which seem to be a mixture of this, *D. racemosa* var. *translucida*, and a third, unidentified species. The specimens cited in the *Flora of Panama* (Gentry, 1973), all of which are sterile, are of this latter species. Both varieties of *D. racemosa* differ from *D. magnoliifolia* in having membranous to subcoriaceous leaflets, with (4)5 to 9 pairs of lateral veins and tertiary and higher order venation immersed to flat on the adaxial surface, and capsules that are relatively broader (8–22 × 3.5–7 cm), densely pubescent, and with a thicker wall (3–5 mm) and an acute to rounded apex. In addition, *D. racemosa* var. *racemosa* differs from *D. magnoliifolia* in having fruits that are not curved and seeds with the wings coriaceous or subcoriaceous, and opaque. *Distictella racemosa* var. *translucida* differs from *D. magnoliifolia* in usually having at least some trichomes on the abaxial surface in the axils of the lateral veins with the midrib and in rarely having distinctive glandular fields at both the leaflet apex and in the basal lateral vein axils. Both varieties of *D. racemosa* are found in forests, *D. racemosa* var. *racemosa* in seasonally inundated forests associated with black water, and *D. racemosa* var. *translucida* in non-inundated forest.

Specimens cited in the *Flora of Ecuador* (Gentry, 1977) for *Distictella magnoliifolia* (*G. Harling* & *L. Andersson* 11947 and *H. Lugo* 3121) pertain to *D. racemosa* var. *translucida*, and specimens cited in the *Flora de Venezuela* (Gentry, 1982) are a mixture of *D. magnoliifolia* (*P. E. Berry* 1382, 1426, 1496; *A. H. Gentry* & *S. Tillett* 10900; *G. Morillo et al.* 3904, 3908, 4199), *D. racemosa* var. *racemosa* (*L. Williams* 15309; *J. J. Wurdack* & *L. S. Adderley* 43008), and *D. racemosa* var. *translucida* (*A. H. Gentry et al.* 10608?;

G. Morillo et al. 4134 [cited as 4143]; *J. A. Steyermark* 107474).

The specimens cited in the *Flora of Panama* (Gentry, 1973) for *Distictella magnoliifolia* (*T. B. Croat* 13183; *A. H. Gentry* 737, 1861, 1882-b, 4125, 4265, 7400) have very large membranous to subcoriaceous leaflets with the tertiary veins raised on the abaxial surface and the midrib, lateral veins, and lateral vein axils pubescent with additional tissue domatia at the axils of the lateral veins with the midrib. The same taxon is known from Costa Rica (*A. H. Gentry* 1116 [MO], 71770-a [MO], and *J. F. Morales* 3212 [INB]) and is treated by Burger and Gentry (2000) as *D. magnoliifolia*. All of this material is sterile excluding parts of the valves of three old fruits, one with seeds. The fruits are broadly oblong, 15.5–23.5 × 5–5.5 cm, slightly curving, drying dull brown, pubescent with very small white trichomes, the base and apex acute, the midrib subevident, and the wall 5–7 mm thick. The seeds are ca. 22 × 90 mm, the wings poorly demarcated, light brown, membranous, hyaline especially at tips, and without irregular ridges and dots of darker color. It is uncertain what genus these specimens belong to; the absence of ridges and dots on the membranous seed wing would be unique in the genus *Distictella*.

Selected specimens examined. BRAZIL. **Amazonas:** Km 130, Manaus–Caracarai Rd. (BR 174), *A. H. Gentry* 12969 (MO); Presidente Figueiredo, Represa de Balbina on Rio Uatumã, ca. 4 km NW of dam on D-1 rd., *W. W. Thomas et al.* 5336 (MO). COLOMBIA. **Guainía:** Bana vegetation on white sand, near airport of San Felipe, *A. H. Gentry & B. Stein* 46381 (MO). **Vaupés:** Yurupari, *P. H. Allen* 3210 (MO). VENEZUELA. **Amazonas:** IVIC study area, 4 km E of San Carlos de Río Negro, *R. Liesner* 3784 (MO); 8 km from San Carlos de Río Negro on rd. to Solano, *P. E. Berry* 1426-a (MO).

11. *Distictella mansoana* (DC.) Urb., Repert. Spec. Nov. Regni Veg. 14: 310. 1916. Basionym: *Bignonia mansoana* DC. in A. DC., Prodr. 9: 157. 1845. *Distictis mansoana* (DC.) Bureau ex B. Verl., Rev. Hort. 40: 154. 1868, as “*mensoana*.” TYPE: Brazil. Near Cuiabá, s.d., *A. Silva Manso* s.n. (holotype, G-DC not seen, microfiche 9:157.79!).

Liana; young branchlets terete, sometimes flattened at nodes, drying dull brown, black, or gray, usually solid, densely lepidote, pilose, tomentose, or trichomes erect to ascending; trichomes dull white, ferruginous, or tan, 0.1–0.7 mm; pseudostipules rarely present, obovate or linear, thick, 3–7 × 1–1.5 mm. Leaves bifoliolate, trifid tendril sometimes present; petiole 12–63 mm, with pubescence like that of branchlets; petiolules 5–25 mm, with pubescence like

that of branchlets; leaflets ovate, lanceolate, or elliptic, 5–17 × 3–12 cm, chartaceous, 3 to 6 pairs of lateral veins, each lateral vein initiating at a 20°–30° (–45°) angle with the midrib and extending toward apex before curving and anastomosing with tertiary veins, tertiary veins inconspicuous, generally anastomosing with higher order venation to form a loosely closed network, midrib and lateral veins immersed adaxially and tertiary veins usually raised, all veins raised abaxially, both surfaces drying olive-green or yellowish green, adaxial surface with trichomes dense along midrib, dense to scattered on lateral veins, and sometimes scattered over surface, abundantly lepidote, with or without scattered glands, abaxial surface pilose to tomentose with white trichomes 0.1–0.6 mm, abundantly lepidote, usually with fields of glands in the axils of the basal lateral veins with the midrib (rarely absent), and sometimes in additional axils, margin flat, base rounded, or nearly so, or subcordate (rarely somewhat acute), apex acute, short-acuminate, or obtuse-cuspidate. Inflorescence a racemose panicle (rarely raceme), peduncle with rachis 6–45 cm with 4 to 30 flowers, peduncle 2–5 mm wide at base, peduncle, rachis, and pedicels drying dull brown, black, or gray, minutely puberulent with trichomes erect to ascending, ferruginous or white, or sometimes with trichomes like those of branchlets, bracteoles 4–8 × 1–3 mm, lost before anthesis; calyx 10–15 × 9–12 mm, coriaceous, pubescent with minute, appressed, tan to ferruginous trichomes and lepidote, glandular fields 2 or 2.5 pairs; corolla white with yellow throat (corolla reportedly purple, *F. Machado & S. Assumpção* S. s.n., SP8976), infundibular from cylindrical base, curved 1/3 distance from base, 5–8.5 cm, coriaceous, tube 3.5–6.7 cm with cylindrical base 9–17 mm long and mouth 17–30 mm wide, externally and internally pubescent with minute trichomes above glabrous base, internally villous at bases of stamens and staminode, lobes 13–24 × 13–25 mm; stamens and staminode inserted 8–16 mm from base of corolla tube, anthers 4–5 mm, longer filaments 24–32 mm, shorter filaments 18–26 mm, staminode 6–9 mm; disc 1–2 × 4–6.5 mm; pistil 3.7–4.9 cm, ovary 3–6 × 2–2.8 mm, stipe 0.5–1.5 mm, stigma lanceolate or subulate. Capsule elliptic or oblong, curved, 9.5–16 × 2.6–4.7 cm, 1.2–2.5 cm diam., base acute and truncate, acute, or rounded, apex obtuse, acute, or acute or obtuse and apiculate, one valve concave and the other convex, drying golden brown, densely tomentose with minute white, ferruginous, or tan trichomes, glandular and usually warty, midrib prominent, wall 2–3 mm thick. Seeds 13–20 × 38–55 mm, wings well demarcated from seed body, reddish brown with tips lighter brown, membranous, hyaline, the veins contrasting in color to surface

(Figure: Lohmann & Hopkins, 1999: 620 as *Distictella elongata*; Lohmann & Pirani, 1998: fig. 12f–l as *Distictella elongata*; Bureau & Schumann, 1896: fig. 87).

Distribution. *Distictella mansoana* has primarily been collected in central Brazil (Minas Gerais, São Paulo, Goiás, Distrito Federal, and Mato Grosso) and Bolivia (along the border with Brazil in Santa Cruz and Beni, and also La Paz). Additional collections have been found in Brazil in Bahia, Pará, Amazonas, Roraima, and Rondônia and in Peru along the border with Bolivia in Madre de Dios and Puno. It is most often reported from cerrado or pampas, but it is also reported from disturbed areas, gallery forest, and moist forest. It is generally found at elevations over 400 m, but has been collected from 160 to 1400 m elevation. Figure 1B.

Phenology. Flowering primarily from November to February. There are also collections in flower from March, May, June, August, and October; fruiting from April to November.

Discussion. Verlot (1868) published “*Distictis Mensoana*, Ed. Bur.” This could be interpreted as a new species based on *J. Correa de Mello* specimens collected in São Paulo, Brazil, and housed at P. However, digitized images of *J. Correa Mello 13* (P) were seen in this study, and the specimens were annotated by Bureau as *Bignonia mansoana* DC. and *Distictis mansoana* “Bur.” From this it can be deduced that “*Mensoana*” is an orthographic error for *mansoana* and Verlot’s intention was to credit Bureau with the transfer of *Bignonia mansoana* (based on *A. Silva Manso s.n.*) to *Distictis*. This transfer is often cited from later publications: *Distictis mansoana* (DC.) Bureau ex Benth. in Benth. & Hook. f., *Gen. Pl.* 2: 1038. 1876 or *Distictis mansoana* (DC.) Bureau, *Vidensk. Meddel. Dansk Naturhist. Foren. Kjøbenhavn* 1893: 112. 1894.

In *Flora de Venezuela*, Gentry (1982) treated *Distictella mansoana* as a synonym of *D. elongata*. Specimens identified by Gentry as *D. elongata* are treated here as three different species, *D. elongata*, *D. mansoana*, and *D. parkeri*. However, Gentry’s use of the name *D. elongata* in the descriptions and keys in the *Flora de Venezuela* (1982) and *Flora of the Venezuelan Guayana* (1997) appears to be based only on specimens of *D. parkeri*. *Distictella parkeri* differs from *D. mansoana* in the tertiary veins of the leaflets being immersed in the adaxial surface and flat to immersed on the abaxial surface, the midrib of the capsule not evident or only subevident, and the wings of the seed poorly demarcated. *Distictella elongata* differs from *D. mansoana* in having obovate leaflets

with bases shortly attenuate or cuneate, the tertiary veins immersed in the adaxial surface and generally closely spaced and connecting midribs and lateral veins without branching, while the higher order venation forms a fine, closed reticulation. The fruits of *D. elongata* are somewhat smaller (ca. 8 × 2.8 cm), eglandular, and only slightly warty, and the seeds are smaller (8–10 × 25–28 mm) with poorly demarcated wings. Both *D. elongata* and *D. parkeri* are found north of *D. mansoana* in secondary or disturbed forests on white sand. Lohmann and Pirani (1998) and Lohmann and Hopkins (1999) used the name *D. elongata* for *D. mansoana*, following Gentry’s (1982) synonymy and specimen identifications.

Distictella mansoana is also similar to, and sometimes confused with, *D. arenaria*. *Distictella arenaria* differs from *D. mansoana* in having conspicuous, broader, and more persistent pseudostipules (3–10 × 3–5 mm), leaflets with the tertiary veins immersed on the adaxial surface, petiolules usually longer than the petioles, capsules thinner (ca. 0.3 cm diam.) with the midrib not or only slightly evident, and seeds with the wings poorly demarcated. It is also found north of *D. mansoana* on white sand.

Distictella mansoana and *D. magnoliifolia* are the only species in the genus with the tertiary veins raised on both the adaxial and abaxial leaflet surfaces. However, the two are quite different in other aspects. *Distictella magnoliifolia* has coriaceous leaflets with the abaxial surface without trichomes and the capsules dry black, are nearly without trichomes, and have long attenuate apices.

Selected specimens examined. BOLIVIA. **Beni:** 15 km SW of Guajará–Mirim on rd. to Riberalta, *W. R. Anderson 11965* (MO). **La Paz:** Prov. Larecaja, 19 km al SO de Guanay por el camino a Tipuani, *J. C. Solomon 17685* (MO); Nor Yungas, 21.1 km al NO del camino entre Yolosa y Caranavi por el camino a Suapi (ca. 2.5 km al O de Suapi, cerca del Puente sobre el Río Suapi), *J. C. Solomon 18428* (MO). **Santa Cruz:** Velasco Prov., Parque Nacional Noel Kempff M. Pampa Grande de Bella Vista, *R. Guillén et al. 3897* (MO). BRAZIL. **Amazonas:** Reserva Florestal Ducke, Manaus–Itacoatiara, Km 26, *L. G. Lohmann et al. 70* (MO). **Bahia:** Mpio. Barreiras, Roda Velha, *G. Hatschbach 39444* (MO). **Distrito Federal:** Rio Torto, near Sobradinho, *H. S. Irwin et al. 11445* (MO); Córrego Jeriva, E of Lagôa Paranoá, *H. S. Irwin et al. 15389* (MO). **Goiás:** Rio Cristal 44 km by rd. SE of Cristalina, *W. R. Anderson et al. 8273* (MO); Rio S. Patricio, Mun. Pirenópolis, *G. Hatschbach & T. P. Rammooorthy 38187* (MO). **Mato Grosso:** ca. 20 km S of Xavantina, *H. S. Irwin et al. 16821* (MO); 10 km W de Chapada dos Guimarães, *S. Ferrucci 793* (MO); Porto XV, Mun. Bataguáçu, *G. Hatschbach 23542* (MO). **Minas Gerais:** ca. 40 km NE of Patrocínio, *H. S. Irwin et al. 25684* (MO); Fazenda da Ilha, Pedregulho, *A. H. Gentry et al. 59173* (MO). **Pará:** Serra do Cachimbo, 2 km W of the Cachimbo airstrip, *J. H. Kirkbride Jr. & E. Lleras 2860* (MO); Alto Tapajós, Rio Cururú, region of Missão Velha, a Mundurukú village, ca. 2 km N of the Rio Cururú, *W. R. Anderson et al. 10945* (MO).

Rondônia: Mun. de Colorado do Oeste, BR 364, Porto Velho–Cuiabá, estrada para Colorado do Oeste, Km 25, *C. A. Cid Ferreira et al.* 4307 (MO); Estrada Vilhena–Pimenta Bueno entre os Kms 640 e 645, Mun. de Vilhena, *M. G. Vieira et al.* 990 (MO). **Roraima:** Indian trail from Surucucu to Uaicá, betw. Maitá & Paramiteri Indian village, *G. T. Prance et al.* 10659 (MO). **São Paulo:** Emas, near Cachoeira, Mun. de Piracicaba, *F. R. Fosberg* 43323 (MO). PERU. **Madre de Dios:** Tambopata Prov., Río Heath, Peru/Bolivia border, *A. H. Gentry & P. Núñez* 69789 (MO). **Puno:** Poto, *R. Pearce s.n.* (BM).

12. *Distictella monophylla* Sandwith, Mem. New York Bot. Gard. 9: 361. 1957. TYPE: Venezuela. Amazonas: Cerro Sipapo (Paráque), Camp Savanna, 1500 m, 15 Dec. 1948, *B. Maguire & L. Politi* 27717 (holotype, K not seen; isotype, NY not seen, microfiche 947.A7!, digitized image!).

Shrub, erect to semi-scandent, 1–2.5 m; young branchlets terete, drying dull brown or black, solid, sometimes lepidote, densely pubescent with trichomes usually tightly appressed (rarely ascending); trichomes dull white, ca. 0.3 mm; pseudostipules absent or not seen. Leaves unifoliolate, without tendril or tendril scar; petiole 3–10 mm, pubescence like that of branchlets; leaflets oblong (rarely ovate), 3–9.5 × 1.7–7.5 cm, coriaceous, 3 to 5(6) pairs of lateral veins initiating at a 45° angle with midrib or less and extending toward apex, anastomosing with tertiary veins and fading, tertiary veins conspicuous abaxially, anastomosing with high order venation to form a fine, closed network, midrib and lateral veins usually flat adaxially and tertiary veins raised, occasionally tertiary veins flat or all immersed, all raised abaxially (except sometimes flat in young leaflets), both surfaces drying blackish green (rarely pale green), adaxial surface with scattered, appressed trichomes, or trichomes restricted to main veins, or without trichomes, scattered lepidote, sometimes with scattered glands, and glands concentrated at apex and/or base, abaxial surface with small, straight white trichomes along (and sometimes on) veins and veinlets, generally pointing into areoles (sometimes also in areoles), lepidote, without obvious glands, margin revolute, base rounded or subcordate, apex rounded or obtuse, often apiculate, sometimes emarginate. Inflorescence a raceme (rarely racemose panicle), peduncle with rachis 2–4.5 cm with 1 to 6(20) flowers, peduncle 1–2 mm wide at base, peduncle, rachis, and pedicels drying gray, pubescent with trichomes like those of stem, bracteoles absent or not seen; calyx 6–8 × ca. 7 mm, membranous, pubescent with minute white, appressed trichomes, glandular fields 2 to 3.5 pairs; corolla white, pale purple, or white with purple lobes, sometimes with yellow throat, infundibular from cylindrical base,

weakly curved ca. 1/2 distance from base, 4.5–6 cm, membranous, tube 3.6–4.1 cm with cylindrical base 5–8 mm long and mouth 15–20 mm wide, externally densely puberulent with minute trichomes above glabrous base, internally puberulent and lepidote with villous clusters of trichomes at bases of stamens and staminode, lobes 10–15 × 10–15 mm; stamens and staminode inserted 4.5–8 mm from base of corolla tube, anthers 3.5–4 mm, longer filaments 22–23 mm, shorter filaments 17–18 mm, staminode 2–3 mm; disc 1–2 × 2.5–4 mm; pistil 3–3.3 cm, ovary 2.5–3 × ca. 1.2 mm, stipe not distinct, stigma lanceolate. Capsule elliptic, not curved, 4.2–7 × 2–2.6 cm, ca. 0.2–0.3 cm diam., base rounded, apex attenuate, valves compressed, drying brown, or grayish or greenish brown, densely puberulent with minute, white trichomes, scattered glands, often with granular appearance, midrib not evident, wall 1–1.5 mm thick. Seeds 10–15 × 23–32 mm, wings well demarcated from seed body, reddish brown with tips yellowish tan, membranous, hyaline at least at tips, the veins contrasting in color to surface.

Distribution. *Distictella monophylla* is known from Amazonas, Venezuela, and (reported by Sandwith, 1957) from adjacent areas in Colombia. It is often found in white sand savannas, between 100 and 1500 m. Figure 1A.

Phenology. Flowering February, March, May–July, November, and December; fruiting February, March, July, and October.

Discussion. The only other species of *Distictella* known to have unifoliolate leaves is *D. laevis* (first pair of leaves sometimes unifoliolate in *D. campinae*). These are also the only two species of *Distictella* that are ever erect shrubs. They differ from each other primarily in the abaxial surface of the leaves, without trichomes in *D. laevis* with the tertiary veins immersed to flat and loosely open-reticulate and the margin flat. Their geographic ranges and habitats overlap, but *D. laevis* has not been collected above 400 m.

Leaves of *Distictella monophylla* are similar to the leaflets of the bifoliolate liana, *D. obovata*. However, the species differ not only in habit and leaflet number but also leaflet shape (generally obovate or oblanceolate in *D. obovata*), base (cuneate in *D. obovata*), surface drying color (bicolored and glossy adaxially in *D. obovata*), and capsule drying color (dull black in *D. obovata*).

Selected specimens examined. VENEZUELA. **Amazonas:** Savanna and forest edge just S of Budare, on S bank of upper Río Temi, 15.3 km (air) SW of Yavita, *P. E. Berry et al.* 6173 (MO); Dpto. Atabapo, Alto Río Orinoco, 15 km al W de La Esmeralda, Cerro Baraco, *G. Aymard & L. Delgado* 8383 (MO); Dpto. Atures, 10 km al S de Río Autana y 15 km al SW del Cerro Autana, *O. Huber* 4061 (MO); Dpto. Río

Negro, vertiente oriental del Macizo Aracamuni, O. Huber & E. Medina 5892 (MO).

13. *Distictella obovata* Sandwith, Mem. New York Bot. Gard. 9: 362. 1957. TYPE: Guyana. Upper Mazaruni River, Kataima, 500 m, 17 Nov. 1951, B. Maguire & D. B. Fanshawe 32637 (holotype, K not seen; isotype, NY not seen, microfiche 947/A9!, digitized image!, US not seen, digitized image!).

Liana; young branchlets terete, drying black (rarely brown-green), solid, lepidote, pubescent with trichomes appressed to spreading; trichomes white-translucent, 0.1–0.3 mm; pseudostipules rarely present, subulate or clavate, 4–6 × 0.5–1 mm. Leaves bifoliolate, trifid tendril sometimes present; petiole 3–15 mm, with pubescence like that of branchlets; petiolules 6–12 mm, with pubescence like that of branchlets; leaflets obovate or oblanceolate (rarely elliptic), 2.8–9(11.2) × 1.5–4(4.8) cm, coriaceous, 3 or 4(5) pairs of lateral veins, each lateral vein initiating at a 45° angle with the midrib and curving toward the apex before fading, tertiary veins conspicuous, but not always distinct from higher orders of venation, strongly reticulate with higher order venation forming a fine, closed network, all veins immersed adaxially and raised abaxially, adaxial surface drying glossy, black or brown-green, generally without trichomes or nearly so except along midrib (and sometimes trichomes scattered on surface), scattered lepidote, usually without glands, abaxial surface grayish brown-green or grayish yellow-green, with covering of small white-translucent trichomes erect then curving primarily in areoles (rarely evenly distributed), scattered lepidote, without glands, or glands scattered in basal area (rarely concentrated into fields), margin recurved, base cuneate, apex rounded, rounded and apiculate (rarely obtuse and cuspidate). Inflorescence a raceme, peduncle with rachis 15–20 cm with ca. 10 flowers, peduncle ca. 2 mm wide at base, peduncle, rachis, and pedicels drying black, pubescent with trichomes like those of branchlets, bracteoles absent or not seen; calyx 8–10 × 9–10 mm, membranous, pubescent with minute, white, appressed trichomes and lepidote, glandular fields 2 or 2.5 pairs; corolla white with yellow throat, infundibular from cylindrical base, curved 1/3 distance from base, (4–)6.5–7 cm, chartaceous, tube (3.5–)5 cm with cylindrical base 8–15 mm long and mouth (10–)15–25 mm wide, externally and internally densely pubescent with minute trichomes above glabrous base (or rarely internally lepidote), internally with villous clusters of trichomes at bases of stamens and staminode, lobes 15–20 × 15–22 mm; stamens

and staminode inserted 7–10 mm from base of corolla tube, anthers 3–4 mm, longer filaments 20–24 mm, shorter filaments 16–20 mm, staminode 5–6 mm; disc ca. 2 × 4 mm; pistil ca. 3.7 cm, ovary ca. 4 × 2.5 mm, stipe not distinct, stigma lanceolate. Capsule narrow-elliptic, not curved, (4–)8–9 × (1.8–)2.8–3 cm, ca. 0.4 cm diam., base acute and truncate, apex acuminate, both valves somewhat compressed, drying dull black, pubescent with minute, appressed, white trichomes, very warty and somewhat wrinkled, midrib subevident, capsule splitting along midrib at maturity, wall 1.5–2 mm thick. Seeds (8–)10–18 × 30–40 mm, wings poorly demarcated from seed body, reddish brown with tips lighter, membranous, hyaline, especially at tips, the veins contrasting in color to surface.

Distribution. *Distictella obovata* is known from the region of the Pakaraima Mountains of Guyana, and across the border into Bolívar, Venezuela. It is found in savannas and disturbed or low forests from 450–1660 m elevation. Figure 1A.

Phenology. Flowering May, June, and October; fruiting May.

Discussion. Leaflets of *Distictella obovata* strongly resemble the leaves of *D. monophylla* in venation, pubescence, margin, and apex, and Sandwith (1957) suggested that *D. obovata* might prove to be a scandent bifoliolate form of the simple-leaved, shrubby *D. monophylla*. However, the two species vary not only in leaflet number and in habit but also leaflet shape (oblong or ovate in *D. monophylla*), base (rounded or subcordate in *D. monophylla*), surface drying color (both surfaces similar in *D. monophylla*), and capsule color (brown in *D. monophylla*). *Distictella monophylla* is endemic to Amazonas, Venezuela, and adjacent areas in Colombia (Sandwith, 1957) and is found in white sand savannas.

Sandwith (1957) also compared *Distictella obovata* to *D. cuneifolia* based on their similar leaflet shapes. *Distictella cuneifolia* has leaflets without trichomes and with more lateral veins (5 to 7 pairs), the higher order venation flat to immersed in the abaxial surface, and a generally flat margin and reddish brown capsules with a prominent midrib. *Distictella cuneifolia* is endemic to Bolivia where it is found in pampas or savannas with black, silty soil.

The shape of the leaflets of *Distictella obovata* and *D. elongata* can be similar, and these specimens are frequently misidentified. The leaflets of *D. elongata* are chartaceous to subcoriaceous, tomentose on the abaxial surface, the margin always flat, and the lateral veins at a steep (20°) angle. In addition, the inflorescence is paniculate and the fruits are golden-brown, curved, and have a prominent midrib. *Distictella*

elongata is also found at lower elevations (sea level to 200 m), east of the range of *D. obovata*, in secondary forests growing on white sand.

Selected specimens examined. GUYANA. Pakaraima Mtns., Mt. Aymatoi, *P. J. M. Maas et al.* 5711 (MO); Pakaraima Mtns., Mora forest, N of Kamarang, *P. J. M. Maas et al.* 4307 (MO); upper Mazaruni River basin, Merume Mtns., Imbaimadai savannahs, near mouth of Partang River, *S. S. Tillett & C. L. Tillett* 43837 (MO); Cuyuni–Mazaruni Region, vic. of Utshe River, *T. McDowell & D. Gopaul* 2864 (MO). VENEZUELA. **Bolívar:** Quebrada El Cajón, Puente Luis Raúl Vásquez Z., 26.5 km E de Icabarú, *J. A. Steyermark et al.* 117818 (MO); Distr. Piar, Río Aparamán, Kambay-merú rapids, ca. 3 km SE of SSE corner Amaruay tepui, *R. Liesner & B. Holst* 20668 (MO).

14. *Distictella parkeri* (DC.) Sprague & Sandwith, Bull. Misc. Inform. Kew 1932: 90. 1932. Basionym: *Bignonia parkeri* DC. in A. DC., Prodr. 9: 157. 1845. TYPE: Guyana. Demerara, 1826, *Parker s.n.* (holotype, G-DC not seen, microfiche G-DC 9.157.80!, photo F neg. 7637!).

Distictis guianensis Klotzsch ex Bureau & K. Schum. in Mart., Fl. Bras. 8(2): 176. 1896; *Distictella guianensis* (Klotzsch ex Bureau & K. Schum.) Urb., Repert. Spec. Nov. Regni Veg. 14: 310. 1916. TYPE: Guyana. Banks of Demerara River, s.d., *M. R. Schomburgk* 1709 (holotype, B presumed destroyed).

Liana; young branchlets terete, flattened at nodes, drying brownish green to dull brown, usually hollow, lepidote, densely pubescent with trichomes ascending; trichomes dull white or ferruginous, to 0.06–0.1 mm; pseudostipules rarely present, falcate or clavate, thick, 4.5–8 × 2–4 mm. Leaves bifoliolate, trifid tendril sometimes present; petiole 13–35(50) mm, with pubescence like that of branchlets; petiolules 13–25 mm, with pubescence like that of branchlets; leaflets ovate, obovate, or elliptic-oblong, 9.7–22.3 × 4.8–12.5 cm, subcoriaceous (rarely chartaceous or coriaceous), 4 to 6 pairs of lateral veins, each lateral vein initiating at a 45° angle with the midrib and curving toward the apex, anastomosing with tertiary veins and fading, tertiary veins inconspicuous, weakly connecting midrib and lateral veins and loosely reticulate with higher order venation, all veins immersed adaxially, midrib and lateral veins raised abaxially, tertiary veins flat to immersed, adaxial surface drying brown-green, brownish yellow-green, or dark brownish green, without trichomes except for midrib and sometimes lateral veins (rarely scattered trichomes on surface), abundantly lepidote, usually with scattered glands, abaxial surface drying brownish green, brownish yellow-green, or grayish yellow-green, densely tomentose with white trichomes to 0.15 or 0.2 mm, abundantly lepidote, with fields of

glands in the axils of the basal lateral veins with the midrib, often also some scattered glands especially at apex, margin flat, base rounded, subcordate, or cordate, apex obtuse and cuspidate (rarely apiculate or rounded and apiculate). Inflorescence a racemose panicle, peduncle with rachis 15–35 cm with 17 to 34 flowers, peduncle 3–4 mm wide at base, peduncle, rachis, and pedicels drying dull brown or brownish green, pubescent with trichomes like those of branchlets or trichomes smaller, bracteoles 2–5 × ca. 1 mm, lost prior to anthesis; calyx 10–13 × 10–11 mm, coriaceous, pubescent with minute, ferruginous or white, appressed trichomes and lepidote, glandular fields 2 pairs; corolla white with yellow throat, infundibular from cylindric base, curved 1/4–1/2 distance from base, 5.5–8 cm, subcoriaceous, tube 4.3–6 cm with cylindric base 10–13 mm long and mouth 20–25 mm wide, externally and internally densely pubescent with minute trichomes above glabrous base, internally with villous clusters of trichomes at bases of stamens and staminode, lobes 12–20 × 13–20 mm; stamens and staminode inserted 8–10 mm from base of corolla tube, anthers 4–5 mm, longer filaments 23–29 mm, shorter filaments 19–23 mm, staminode 2–6 mm; disc ca. 1.5 × 4–5.2 mm; pistil 3.9–4.6 cm, ovary 4–4.2 × 1.5–2.5 mm, stipe 0.5–1.5 mm, stigma lanceolate. Capsule oblong, strongly curved, 12–12.5 × 3.5–3.6 cm, ca. 1.3 cm diam., base acute and truncate, apex acute or acute and rounded, with one valve concave and the other convex, drying reddish brown or golden, densely pubescent with trichomes like leaflets or golden or red, with numerous glands overall or glands numerous but restricted to margins, warty or granular (sometimes only on margins), midrib not at all or only subevident, capsule sometimes splitting along midrib at maturity, wall 2–4 mm thick. Seeds 15–20 × 55–62 mm, wings poorly demarcated from seed body, reddish brown with tips lighter brown, membranous, hyaline, the veins contrasting in color to surface (Figure: Gentry, 1997: fig. 375, as *Distictella elongata*).

Distribution. *Distictella parkeri* is known from the Guianas, Bolívar, Venezuela, and Amapá, Brazil. It is generally found in disturbed forest, often described as on white sand, at elevations between sea level and 500 m. Figure 1B.

Phenology. Flowering January, March, June, September, October, and December; fruiting March and May.

Discussion. Sprague and Sandwith (1932) studied the holotype of *Distictis guianensis* and treated *D. guianensis* as a synonym of *Distictella parkeri*. This placement, which is supported by the original

description of *Distictis guianensis* (Bureau & Schumann, 1896), is followed here.

Distictella parkeri is treated in the *Flora of Venezuela* (Gentry, 1982; based on *A. H. Gentry et al. 10660* and *J. A. Steyermark 90641*, not seen) and the *Flora of the Venezuelan Guayana* (Gentry, 1997) as *D. elongata*, a species that has leaflets with attenuate or cuneate bases, lateral veins at a steep (20°) angle to the midrib, abaxial surfaces with a raised and finely closed network of veins, and capsules with a prominent midrib.

Distictella parkeri is closest to *D. lohmanniae*, which differs in having leaflets that are bicolored, the adaxial surface drying dark blackish green, the abaxial surface covered with appressed, minute trichomes to 0.03 mm long, lateral veins forming a steep (20°) angle with the midrib, tertiary veins generally parallel, closely set, and nonbranching, smaller inflorescences (peduncle with rachis 6–11 cm), slightly curved fruit with a prominent midrib, and seeds with the wings well demarcated. *Distictella lohmanniae* is endemic to Amazonas, Brazil.

Another similar species is *Distictella mansoana*, treated by Gentry as a synonym of *D. elongata* (Gentry, 1982). *Distictella mansoana* differs from *D. parkeri* in the tertiary veins of the leaflets being usually raised on both surfaces, the very elevated and swollen midrib of the capsule, and the well-demarcated wings of the seeds. *Distictella mansoana* is distributed south of *D. parkeri*.

Distictella parkeri can also be compared with *D. racemosa* var. *translucida*. The latter has the abaxial surface of the leaflets generally with trichomes restricted to the axils of the lateral veins with the midrib and occasionally with trichomes also on the major veins, or rarely without trichomes, capsules with a prominent midrib, and leaflet bases acute, obtuse, or rounded.

Selected specimens examined. BRAZIL. **Amapá:** Mun. de Calçoene, BR156 in vic. of government rd. camp Carnot, 53–72 km WNW of Calçoene, *B. V. Rabelo et al. 2858* (MO). FRENCH GUIANA. Cayenne–Regina hwy., 5–6 km N of crossing of Riviere La Comte, *A. H. Gentry & E. Zardini 50256* (MO); Bord de la rte. de l'Est, Km 38, *M.-F. Prévost 428* (MO). GUYANA. Cuyuni–Mazaruni Region, along Mazaruni River, confluence with Kamarang River to ca. 3 km upstream, *T. McDowell & D. Gopaul 2575* (MO); upper Demerara–Berbice Region, Fairview Landing E bank of Essequibo River, near end of Mabura rd., *T. McDowell 3250* (MO); West-Demerara, Mabura Hill, 180 m SSE of Georgetown, Mabura main rd., *H. ter Steege et al. 398* (MO); Potaro–Siparuni Region, Kaieteur Natl. Park, betw. airstrip & escarpment, *L. J. Gillespie 902* (MO). SURINAME. **Marowijne Distr.:** Vic. of Patamacca Village, 25 km S of Moengo, *B. Hoffman & M. van Roosmalen 5355* (MO). VENEZUELA. **Bolívar:** Tumeremo to Anacoco (N side of Cuyuni River), 61 km from Guyana frontier at Anacoco, *A. H. Gentry et al. 10660* (MO).

15. *Distictella pauciflora* A. H. Gentry, *Ann. Missouri Bot. Gard.* 61: 872. 1974. TYPE: Venezuela. Bolívar: Región de Canaima, entre el hotel y el Salto Hacha, 400 m, 6°15'N, 62°47'W, 18 July 1972, *J. A. Steyermark 106343* (holotype, MO!).

Liana; young branchlets terete, drying grayish green, solid, densely lepidote, pubescent with appressed trichomes or glabrescent; trichomes dull white, to 0.03 mm; pseudostipules absent. Leaves bifoliolate, tip of tendril not seen; petiole 8–20 mm, with dense, white and ferruginous trichomes to 0.03 mm, lepidote; petiolules 4–7 mm, with pubescence like that of petioles; leaflets elliptic or lanceolate-elliptic, 5.5–13 × 1.4–4.2 cm, subcoriaceous, 4 to 7 pairs of lateral veins, each lateral vein initiating at a 45° angle with the midrib and curving toward the apex, anastomosing with tertiary veins and fading, tertiary veins inconspicuous, connecting midrib and lateral veins and weakly reticulate with higher order venation forming a loosely closed network, all veins immersed adaxially, midrib and lateral veins raised, and tertiary veins flat to immersed abaxially, both surfaces drying brownish green, adaxial surface, without trichomes, abundantly lepidote, without scattered glands, abaxial surface without trichomes, densely lepidote, with scattered glands, glandular fields sometimes in basal lateral vein axils with midrib, margin flat, base cuneate, apex long-acuminate. Type with one terminal flower and one flower from axil of uppermost leaf, peduncle with pedicel 2.5–5 cm, peduncle ca. 1 mm wide at base, peduncle and pedicels drying grayish green, pubescent with trichomes like branchlets, bracteoles absent or not seen; calyx 8–9 × 7–8 mm, coriaceous, pubescent with scattered minute, ferruginous, appressed trichomes and densely lepidote, glandular fields at least 1 pair; corolla white with pale lavender lobes, infundibular from cylindrical base, curved 1/4 distance from base, 5–6 cm, chartaceous, tube 3.5–4.5 cm with cylindrical base ca. 10 mm long and mouth 13–18 mm wide, externally densely pubescent with minute trichomes above glabrous base, internally densely pubescent apically, less so basally with villous clusters of trichomes at bases of stamens and staminode, lobes 13–20 × 13–20 mm; stamens and staminode inserted 7–10 mm from base of corolla tube, anthers ca. 4 mm, longer filaments 19–21 mm, shorter filaments 17–19 mm, staminode at least 2 mm (broken); disc ca. 1 × 3 mm; pistil 3.6–3.7 cm, ovary ca. 4 × 1.5 mm, stipe ca. 1 mm, stigma lanceolate. Capsule not known.

Distribution. *Distictella pauciflora* is known only from the type (Bolívar, Venezuela). Figure 1B.

Phenology. Flowering July; fruiting not known.

Discussion. *Distictella pauciflora* is most similar to narrow-leaved specimens of *D. racemosa* var. *racemosa* (such as the types of its synonyms *Bignonia rusbyi* Britton ex Rusby and *Distictis angustifolia*) but differs from these in its greatly reduced and delicate inflorescence. *Distictella pauciflora* is unusual in this generally white-flowered genus in having lavender corolla lobes, though *D. monophylla* is frequently described as having pale purple corollas (at least in part), one specimen of *D. racemosa* var. *translucida* was reported to have corollas with lavender lobes, and one specimen of *D. mansoana* was described as having purple corollas. Curiously, the illustration in the *Flora of the Venezuelan Guayana* (Gentry, 1997) depicts a plant with an elongate raceme with at least seven flowers. It is possible that *D. pauciflora* is a depauperate specimen of *D. racemosa*.

16. *Distictella porphyrotricha* Sandwith, Bol. Soc. Venez. Ci. Nat. 25(106): 48. 1963. TYPE: Venezuela. Bolívar: Río Cuyuni drainage, 135 km S of El Dorado, NE of Luepa, 800–1200 m, 6–11 Mar. 1962, J. A. Steyermark & L. Aristeguieta 98 (holotype, K not seen; isotypes, NY not seen, microfiche 947/A11!, digitized image!, US not seen, digitized image!).

Liana; young branchlets terete, drying dark red, solid, pubescent with erect to spreading trichomes; trichomes ferruginous, the longest 1.5–2 mm; pseudostipules occasionally present, falcate, thick, 2.5–3 × 1–1.2 mm. Leaves bifoliolate, trifid tendril usually present; petiole 3–10 mm, with pubescence like that of branchlets; petiolules 7–20 mm, with pubescence like that of branchlets; leaflets elliptic to oblanceolate, 4–12.5 × 2–8.4 cm, subcoriaceous to coriaceous (sterile specimens sometimes chartaceous), 4 to 6(7) pairs of lateral veins, each lateral vein initiating at a 45° angle with the midrib and curving toward the apex before anastomosing with the tertiary veins and fading, tertiary veins conspicuous, anastomosing with the higher order venation to form a loosely closed network, all veins immersed adaxially and raised abaxially, both surfaces drying brownish green, adaxial surface bullate (not always so in sterile collections), with red, erect trichomes, 0.8–2 mm, dense to scattered on main veins and scattered on surface, scattered lepidote, without glands, abaxial surface with dense, white or red trichomes, 0.6–1.5 mm, erect to spreading, or pilose, abundantly lepidote, without visible glands, margin recurved, base rounded, subcordate, or cuneate, apex obtuse or rounded, apiculate (sometimes on sterile collections long attenuate, or cuspidate). Inflorescence a raceme

or racemose panicle, peduncle with rachis 4.5–12 cm with 10 to 20 flowers, peduncle 3–4 mm wide at base, peduncle, rachis, and pedicels drying reddish brown to dark reddish purple, pubescent with trichomes like branchlets, or trichomes smaller and ascending, bracteoles 2–5 × 1–1.5 mm, usually present in flower; calyx 8–14 × 6–14 mm, subcoriaceous, pubescent with dense, red, spreading to ascending or appressed trichomes to 0.3 mm, glandular fields 2.5 pairs; corolla white with yellow throat, infundibular from cylindric base, curved 1/5–1/3 distance from base, 4–5.3 cm, subcoriaceous, tube 3–4 cm with cylindric base 10–13 mm long and mouth 15–20 mm wide, externally and internally densely pubescent with minute trichomes above glabrous base, internally with villous clusters of trichomes at bases of stamens and staminode, lobes 8–18 × 12–19 mm; stamens and staminode inserted 8–12 mm from base of corolla tube, anthers 4–5 mm, longer filaments 21–24 mm, shorter filaments 16–21 mm, staminode 5–7 mm; disc 1–2 × 3.5–6 mm; pistil 3.1–4.5 cm, ovary 3–4 × 2–2.5 mm, stipe 0.5–1 mm (rarely absent), stigma subulate or rhombic. Capsule obovate-oblong, not curved, ca. 12 × 3.7 cm, base obtuse, apex acuminate, both valves slightly compressed, densely pubescent with ferruginous trichomes, with few scattered glands, midrib inconspicuous, capsule splitting along midrib at maturity. Seeds ca. 20 × 40 mm, wings poorly demarcated from seed body, brown, membranous.

Distribution. *Distictella porphyrotricha* is known from eastern Bolívar, Venezuela, and Amapá, Brazil. It is generally reported from forests on terra firme at elevations between 900 and 1380 m. Figure 2A.

Phenology. Flowering January and March; fruiting May.

Discussion. Fruiting material was not seen in this study; the description here is based on Sandwith (1963), Gentry (1982), and notes by Gentry on the MO photocopy of the K photo *T. Lasser 1793* (VEN).

The only other species of *Distictella* with such long trichomes as *D. porphyrotricha* (1.5–2 mm long) on branchlets, petioles, petiolules, peduncle, and pedicels is *D. dasytricha* (trichomes 1–2 mm long). The other species have trichomes on these parts ranging in length from 0.03–0.7 mm. *Distictella dasytricha* differs from *D. porphyrotricha* most markedly in its leaflets, which are non-bullate and have a fine, closed network formed by the higher order venation. *Distictella dasytricha* also has lateral veins that diverge from the midrib at a much steeper angle (20°), golden-colored trichomes on the branchlets, petioles, petiolules, and inflorescences, bracteoles

that are lost prior to anthesis, and capsules that are curved, smaller (6.8–7.5 cm), with an obtuse to rounded apex and prominent midrib, and it is found at lower elevations (ca. 240 m), often in swamp forests.

Additional specimens examined. BRAZIL. **Amapá:** Mun. de Mazagão, margem esquerda do rio Jarí, morro do Filipe III, *M. J. P. Pires et al. 819* (MO), *819-a* (MO). VENEZUELA. **Bolívar:** Alrededor del Km 123, carr. El Dorado–Santa Elena de Uairen, *L. Marcano-Berti et al. 101-981* (MO); Km 122 S of El Dorado, *A. H. Gentry et al. 10571* (MO); Km 133 S of El Dorado, *A. H. Gentry et al. 10565* (MO); 17 km E of El Pauji by rd. & 64 km W of Santa Elena by rd. 4 km N of hwy., Río Las Ahallas, *R. Liesner 19154* (MO); Gran Sabana, ca. 10 km SW of Karaurin Tepui at jct. of Río Karaurin & Río Asadon (Río Sanpa), *R. Liesner 23864* (MO); Gran Sabana, selva de galleria a lo largo de las cabeceras del Río Pacairao, 6 km al N de la Misión de Santa Teresita de Kavanayén, *J. A. Steyermark et al. 115553* (MO); Kavanayén, *T. Lasser 1793* (MO, photocopy of K's photo of sheet at VEN).

17. *Distictella racemosa* (Bureau & K. Schum.) Urb., *Repert. Spec. Nov. Regni Veg.* 14: 310. 1916. Basionym: *Distictis racemosa* Bureau & K. Schum. in *Mart., Fl. Bras.* 8(2): 179. 1896. TYPE: Suriname. Wanica River, s.d., *H. R. Wullschlaegel 1033* (lectotype, designated here, BR 880400 not seen, digitized image!).

Liana; young branchlets terete, the nodes swollen or flattened, drying dull reddish brown, black, or grayish yellow-green, solid (rarely hollow), densely lepidote, pubescent with appressed trichomes or glabrescent; trichomes dull white or ferruginous, to 0.05 mm; pseudostipules rarely present, oblong to elliptic, thick, 3–6 × 1.5–4 mm. Leaves bifoliolate, trifid tendril sometimes present; petiole 7–50 mm, with pubescence like that of branchlets; petiolules 5–25 mm, with pubescence like that of branchlets; leaflets elliptic, 8–20 × 3.3–11.5 cm, membranous to subcoriaceous, (4)5 to 9 pairs of lateral veins, each lateral vein initiating at a 20°–60° angle with the midrib and curving toward the apex before anastomosing with the tertiary veins and fading, tertiary veins inconspicuous, connecting midrib and lateral veins and weakly reticulate with higher order venation forming a loosely closed network, all veins immersed to flat adaxially, midrib raised, lateral veins raised to flat, and tertiary veins immersed abaxially, both surfaces drying brownish green or yellow-green, adaxial surface without trichomes or midrib with minute appressed trichomes, abundantly lepidote, sometimes with scattered glands, abaxial surface with axils of lateral veins with midrib puberulent or pilose, sometimes with additional trichomes on midrib, or without trichomes, abundantly lepidote, sometimes

with glandular fields at apex and/or in basal lateral vein axils with midrib, and sometimes with scattered glands, margin flat, base acute, obtuse, or rounded, apex acuminate, or rounded or obtuse and cuspidate or apiculate. Inflorescence a racemose panicle or raceme, sometimes lateral, peduncle with rachis 7–40 cm with 3 to 30 flowers, peduncle 2–6 mm wide at base, peduncle, rachis, and pedicels drying grayish yellow-green, reddish brown, brown, or black, pubescent with trichomes like branchlets, bracteoles absent or not seen; calyx 6–15 × 6–12 mm, coriaceous, pubescent with minute, ferruginous or dull white, appressed trichomes and lepidote, glandular fields 2 to 5 pairs; corolla white (rarely pale lavender) with yellow throat, infundibular from cylindrical base, curved 1/5–1/2 distance from base, 4.2–8 cm, membranous to coriaceous, tube 3–6 cm with cylindrical base 7–15 mm long and mouth 16–25 mm wide, externally and internally densely pubescent with minute trichomes above glabrous base, internally with villous clusters of trichomes at bases of stamens and staminode, lobes 10–25 × 13–25 mm; stamens and staminode inserted 6–15 mm from base of corolla tube, anthers 3–5 mm, longer filaments 20–30 mm, shorter filaments 15–22 mm, staminode 2–9 mm; disc 1–2 × 3–6 mm; pistil 3.4–5 cm, ovary 3–6 × 1–3 mm, stipe 0.5–1 mm (rarely absent), stigma ovate or subulate. Capsule broadly elliptic, oblong, or oblanceolate, curved or not, 8–22 × 3.5–7 cm, 0.5–4.5 cm diam., base acute, obtuse, or rounded and truncate, apex acute, rounded, obtuse, or obtuse and apiculate, both valves convex to slightly compressed or one valve concave and the other convex, drying dull grayish yellow-green or reddish brown, densely pubescent with minute, appressed white or ferruginous trichomes, with or without glands, granular or not, midrib not evident to prominent, capsule sometimes splitting along midrib at maturity, wall 3–5 mm thick. Seeds 15–28 × 24–85 mm, wings poorly to well demarcated from seed body, brown or gray, or reddish brown with tips yellowish brown, subcoriaceous to coriaceous or membranous, opaque or hyaline, the veins contrasting in color to surface or not.

Distribution. *Distictella racemosa* is known from northern South America to southern Peru, northern Bolivia, and Amazonian Brazil. It is usually found in forests between sea level and 850 m. Figure 2B.

Phenology. Flowering and fruiting throughout the year.

Discussion. Bureau and Schumann (1896) cited two specimens, *H. R. Wullschlaegel 1033* and *C. F. Martius s.n.* as *Distictis racemosa*. Images of two specimens of *H. R. Wullschlaegel 1033* at BR were

seen, and the sheet barcoded BR 880400 was annotated by Schumann and is therefore selected here as the lectotype. The duplicate barcoded BR 880502 was apparently not annotated by Bureau or Schumann and is better considered an isosytype. The *Martius* collection (barcoded M-88916) also does not appear to be annotated by Bureau or Schumann and may, at best, be considered an isosytype.

Gentry (1973, 1977, 1982, 1997) and Burger and Gentry (2000) treated *Distictella racemosa* as a synonym of *D. magnoliifolia*, a synonymy that was suggested by Sandwith (1954). Earlier, Sandwith (1953) had recommended that the two be kept as separate species, emphasizing the elevated tertiary leaf venation and the large distinctive glandular fields at the apex and base of the leaflets of *D. magnoliifolia*. Gentry (1973) found both these characters to be variable and inadequate for specific separation. In the current study, the venation character was found to be consistent, but the glandular field character was not reliable. The leaflets of *D. magnoliifolia* are quite distinct from those of *D. racemosa*. They are heavily coriaceous with only two to four pairs of lateral veins that curve up toward the apex of the leaflet but follow the margin for a considerable distance before fading out. The capsules of *D. magnoliifolia* are very different from those of *D. racemosa*: they are narrowly oblong (8–13.5 × 2–2.5 cm), with a long attenuate apex, with few scattered and minute trichomes, dry black, and have a thin wall (1–2 mm). In addition, the habitat is different. *Distictella magnoliifolia* is found in scrubby or low forests on white sand. *Distictella magnoliifolia* is further separated from *D. racemosa* var. *racemosa* by its curved capsules and membranous and hyaline seed wings.

Two varieties of *Distictella racemosa* are recognized in this study: *D. racemosa* var. *racemosa*, which is found in seasonally inundated forests below 200 m elevation and has seeds with the wings opaque and subcoriaceous to coriaceous and fruits not curved, with both valves convex to slightly compressed; and *D. racemosa* var. *translucida*, which is found in non-inundated forests between 100 and 950 m elevation and has seeds with the wings membranous and hyaline and fruits usually curved with one valve convex and one concave. The two varieties are very difficult to separate when fruits are not present. *Distictella racemosa* var. *racemosa* is always totally without trichomes on the abaxial surface of the leaflets and nearly always has glands at the leaflet apex and in the axils of the basal lateral veins. *Distictella racemosa* var. *translucida* often has trichomes in the axils of the lateral veins with the midrib and rarely has glandular fields in both the basal lateral vein axils and at the apex. In addition, the lateral veins of *D. racemosa* var.

translucida are often at a steeper angle (20°–40°) than those of *D. racemosa* var. *racemosa* (45°–60°). Unfortunately, as the types of the pertinent names are flowering collections and the habitats are not indicated, the names are applied with some uncertainty.

17a. *Distictella racemosa* (Bureau & K. Schum.)
Urb. var. *racemosa*. Figure 3D, E.

Bignonia rusbyi Britton ex Rusby, Bull. Torrey Bot. Club 27: 71. 1900. Syn. nov. TYPE: Bolivia. Jct. of rivers Beni & Madre de Dios, Aug. 1886, *H. H. Rusby 1140* (holotype, NY not seen, digitized image!; isotypes, MICH not seen, MO!).

Distictis angustifolia K. Schum. ex Sprague, Verh. Bot. Vereins Prov. Brandenburg 1908: 120. 1908 [1909]. Syn. nov. *Distictella angustifolia* (K. Schum. ex Sprague) Urb., Repert. Spec. Nov. Regni Veg. 14: 310. 1916. TYPE: Brazil. Amazonas: Marmellos, Rio Madeira, Mar. 1902, *E. Ule 6111* (holotype, presumed at B not seen, F neg. 18440!; isotypes, HB not seen, K not seen, photo neg. 4218 not seen, photocopy!, L not seen, MG not seen).

Distictella lutescens C. V. Freire & A. Samp. in A. Samp & C. V. Freire, Ann. Acad. Brasil. Sci. 8(1): 31. 1936. Syn. nov. TYPE: Brazil. Amazonas: Santa Isabel (Rio Negro), 8 Nov. 1932, *A. Ducke 8022-a* (holotype, R 28725 [as "R 28726"] not seen; isotype, RB 24885!).

Distictella negrensis C. V. Freire & A. Samp. in A. Samp. & C. V. Freire, Ann. Acad. Brasil. Sci. 8(1): 30. 1936. Syn. nov. TYPE: Brazil. Amazonas: Santa Isabel (Rio Negro), margem do rio, 8 Nov. 1932, *A. Ducke 8022* (holotype, R 28726 [as "R 28725"] not seen; isotype, RB 8022!).

Liana; young branchlets terete, the nodes usually swollen (rarely flattened). Leaflets with lateral veins initiating at a 45°–60° angle with the midrib, abaxial surface without trichomes, usually with glandular fields at apex and in axils of basal lateral veins with midrib. Calyx glandular fields 2 to 5 pairs. Capsule broadly elliptic, oblong, or oblanceolate, not curved, 8–16 × 3.5–7 cm, 0.5–4.5 cm diam., base acute, obtuse, or rounded and truncate, apex acute, rounded, obtuse, or obtuse and apiculate, both valves convex to slightly compressed, drying dull grayish yellow-green or reddish brown, densely pubescent with minute, appressed, white or ferruginous trichomes, usually with abundant glands, often granular, midrib not evident to evident, capsule often splitting along midrib at maturity. Seeds 15–28 × 24–45 mm, wings poorly demarcated from seed body, brown or gray, subcoriaceous to coriaceous, opaque, the veins not contrasting in color to surface (Figure: Gentry, 1973: fig. 12, as *Distictella magnoliifolia*).

Distribution. *Distictella racemosa* var. *racemosa* is found primarily along the Amazon and its tributaries in Brazil (Pará, Amazonas, Roraima, and Mato

Grosso), Peru (Loreto), Colombia (Caquetá, Vaupés, and Amazonas), and Bolivia (Pando [type of *Bignonia rusbyi*] and La Paz). It is also found in southern Venezuela (Amazonas) and northern Guyana, Suriname, and French Guiana. It is found in seasonally inundated forests (igapó or várzea), generally associated with black water, usually at elevations below 200 m elevation (one collection from Guyana was collected at 500 m). Figure 2B.

Phenology. Flowering and fruiting throughout the year.

Discussion. *Bignonia rusbyi* is placed in synonymy of *Distictella racemosa* var. *racemosa* based on examination of type material. Because the type of *B. rusbyi* lacks fruits, the varietal placement is not absolute, but is supported by the leaflets without trichomes and with the presence of glands at both the apex and in the basal lateral vein axils and the wide angle of the lateral veins with the midrib (ca. 45°).

Distictis angustifolia is placed in synonymy with some uncertainty. The leaflets of the type collection are narrowly lanceolate and only about one third as wide as long, conditions rarely seen in *Distictella racemosa* var. *racemosa*.

The captions of the plates of *Distictella lutescens* and *D. negrensis* were swapped in the original publication (Sampaio & Freire, 1936). *Distictella lutescens* can be confidently placed in synonymy of *D. racemosa* var. *racemosa* based on examination of the flowering isotype (RB) and illustration of the holotype in fruit. Examination of the isotype (RB) and illustration of the holotype of *D. negrensis* supports its placement in synonymy of *D. racemosa*, but the absence of fruit makes the varietal placement less certain. Its placement in synonymy of *D. racemosa* var. *racemosa* is supported by the secondary varietal characteristics (leaflets without trichomes and with glands at both the apex and in the basal lateral vein axils and lateral veins forming a 45° angle with midrib) and in the collection of the type along the margins of the Rio Negro with the type of *D. lutescens*.

Specimens from Venezuela and Guyana have capsules that are thicker and relatively broader than other collections of *Distictella racemosa* var. *racemosa* and approach *D. cremersii*. However, the seeds in these collections have much larger wings than those of *D. cremersii*, which has the wings nearly completely reduced, and the leaflets are totally without trichomes on the abaxial surface (vs. pilose in the lateral vein axils in *D. cremersii*).

Individuals of *Distictella racemosa* var. *racemosa* with smaller leaflets are often confused with *D. cuneifolia* (leaflets 4.7–8 × 1.8–3.3 cm). However, specimens of *D. cuneifolia* usually can be recognized

by the leaflets, which are often spatulate and lack apical glands, and the fruit, which are spatulate and smaller (6–6.7 × 2.5–2.7 cm) than those of *D. racemosa* var. *racemosa* and have smaller seeds (9–12 × 26–28 mm) with membranous and hyaline wings. *Distictella cuneifolia* is also found in savannas, while *D. racemosa* var. *racemosa* is found in forests.

Selected specimens examined. BOLIVIA. **La Paz:** Prov. Iturrealde, Luisita, W del Río Beni, zona inundada del Río Muqui, S. G. Beck & R. Haase 10132 (MO). BRAZIL. **Amazonas:** Mun. Humayta, near Livramento on Rio Livramento, B. A. Krukoff 6728 (MO). **Mato Grosso:** near Tabajara, upper Machado River region, B. A. Krukoff 1475 (MO). **Pará:** Mun. de Oriximiná, rio Trombetas, C. A. Cid Ferreira et al. 1389 (MO). **Roraima:** Rio Branco, Curiucu, S. Mori et al. 20442 (MO). COLOMBIA. **Amazonas:** Rio Caqueta, Araracuara, A. van Dulmen & N. Matapi 42 (MO). **Caquetá:** Región de Araracuara, quebrada el engaño, 2–5 km arriba desembocadura, D. Restrepo & A. Matapi 484 (MO). **Vaupés:** Mitú and vic., along Río Tí, J. L. Zarucchi 2109 (MO). FRENCH GUYANA. Piste de Risque Tout, Km 10 (environ) à partir de Montsinéry, F. Billiet & B. Jardin 2037 (MO). GUYANA. Potaro–Siparuni Region, Kaieteur Falls Natl. Park, W. Hahn et al. 4761 (MO). PERU. **Loreto:** Banks of Río Nanay, F. Woytkowski 5140 (MO); Requena Prov., Río Tapiche, tributary of Río Ucayali, ca. 1 hr. by 40 h.p. motor above Requena, A. H. Gentry et al. 21293 (MO). SURINAME. High creek forest along Cola Creek at crossing with rd. Zanderij–Saramacea R., N. M. Heyde 599 (MO). VENEZUELA. **Amazonas:** Dep. Atabapo, Caño Negro, río arriba dede la confluencia con el río Cunucunuma, J. A. Steyermark et al. 126235 (MO).

17b. *Distictella racemosa* (Bureau & K. Schum.)

Urb. var. **translucida** A. Pool, var. nov. TYPE: Colombia. Antioquia: autopista Medellín–Bogotá, vereda La Josefina, camino hacia El Pitál, Mpio. de San Luis, 800 m, 29 Nov. 1983 (fr.), S. Hoyos & J. Hernandez 535 (holotype, MO!; isotype, JAUM not seen). Figure 3F, G.

Distictella broadwayana Urb., Repert. Spec. Nov. Regni Veg. 14: 310. 1916. Syn. nov. TYPE: Tobago. Near Menna, 23 Mar. 1914, W. E. Broadway 4753 (holotype, BM not seen, digitized image!).

Haec varietas a varietate typica seminibus alis membranaceis translucidis praeditis et capsula plerumque curva distinguitur.

Liana; young branchlets terete, the nodes usually flattened. Leaflets with lateral veins initiating at a 20°–45° angle with the midrib, abaxial surface with axils of lateral veins with midrib puberulent or pilose, rarely without trichomes, and sometimes with additional trichomes along midrib (rarely also along lateral veins), sometimes with glandular fields at apex, occasionally in basal lateral vein axils, rarely in both locations. Calyx glandular fields 2 or 2.5 pairs. Capsule oblong, curved, 11–22 × 3.5–5.5 cm, 0.5–

2.5 cm diam., base rounded and truncate, apex acute, or acute or obtuse and rounded, one valve concave and the other convex (rarely not curved, and both valves somewhat flattened), drying reddish brown, densely pubescent with minute, appressed, ferruginous trichomes, with or without glands, not granular, midrib prominent. Seeds 15–25 × 55–85 mm, wings poorly to well demarcated from seed body, reddish brown with tips yellowish brown, membranous, hyaline, especially at tips, the veins contrasting in color to surface.

Distribution. *Distictella racemosa* var. *translucida* is known from Tobago (type of *D. broadwayana*), western Colombia (Antioquia, Chocó, Santander, Caquetá, Amazonas), Ecuador (Napo), central Peru (Amazonas, Loreto, San Martín, Junín, Madre de Dios, Puno), southern and eastern Venezuela (Amazonas, Bolívar, Delta Amacuro, Sucre), northwestern Brazil (Amazonas, Acre, Pará, Rondônia, Roraima), and the Guianas. It is usually found in forest in non-inundated areas between 100 and 950 m. Figure 2B.

Phenology. Flowering August to May; fruiting April, May, July, September to December.

IUCN Red List category. The number of collections of *Distictella racemosa* var. *translucida* studied (88) and the wide range of its distribution suggest that this taxon is of Least Concern (LC) status over its entire range, according to IUCN Red List criteria (IUCN, 2001). Threats to particular populations cannot be determined in the present study.

Discussion. Examination of type material of *Distictella broadwayana* places it in synonymy of *D. racemosa* at the species level. This treatment follows that of Sandwith (1938a, 1954, 1965). Because the type of *D. broadwayana* lacks fruits, the varietal placement, as a synonym of *D. racemosa* var. *translucida*, is highly probable but not absolute. The name *D. broadwayana* has been little employed; the only specimen observed annotated with this name was the type, and the only publications accepting this name were those of Urban (1916a, b). It was this lack of name usage in addition to its ambiguity, due to absence of capsule and seed, that led to the decision to publish *D. racemosa* var. *translucida* as a new variety as opposed to simply changing the rank of *D. broadwayana*.

Vegetatively, *Distictella racemosa* var. *translucida* is very similar to *D. cremersii*, which differs in having fruits that are relatively broad and thick (7–11 × 4–5.5 cm, 3–4 cm diam.) and having seeds with the wings almost entirely reduced. Flowering material has not been associated with *D. cremersii*; it is possible that some of the flowering material cited here for *D. racemosa* var. *translucida* is actually *D. cremersii*.

Distictella racemosa var. *translucida* can also be compared with *D. parkeri*. The latter has the undersurface of the leaflets densely tomentose with small trichomes. The midrib of the capsule of *D. parkeri* is not, or only slightly, prominent. In addition, the leaflet base of *D. parkeri* is often cordate or subcordate and never acute or obtuse. Both species can have rounded leaflet bases.

Selected specimens examined. BRAZIL. **Acre:** Vic. of Serra da Moa, G. T. Prance et al. 12191 (MO). **Amazonas:** Mun. Humayta, near Livramento, on Rio Livramento, B. A. Krukoff 6915 (MO). **Pará:** Rio Jarí, Monte Dourado, Serrinha, N. T. Silva 1481 (K). **Rondônia:** Mun. Porto Velho, localidade de Abunã, próximo a antiga estrada de ferro Abunã–Mutumparaná a 2 km de Abunã, C. A. Cid Ferreira 8868 (MO). **Roraima:** Vic. of Uaicá airport, Rio Uraricoeira, G. T. Prance et al. 10903 (MO). COLOMBIA. **Amazonas:** Mpio. Tarapacá, Corregimiento de Tarapacá, Parque Nacional Natural Amaycayacu, sector Lorena (R. Cotuhé), A. Rudas et al. 5151 (MO). **Antioquia:** Autopista Medellín–Bogotá, sector Río Samaná–Río Claro, camino hacia la vereda Tulipán, Mpio. de San Luis, A. Cogollo & C. Estrada 200 (MO). **Caquetá:** 28 km E of Morelia toward Río Pescado, A. H. Gentry et al. 9076 (MO). **Chocó:** New rd. being built from S of Yuto to Lloro, A. H. Gentry & M. Fallen 17815 (MO). **Santander:** Las Colonias (Carare Opón Santander), E. Renteria et al. 1545 (MO). ECUADOR. **Napo:** Rd. Coca, Puerto Francisco de Orellana–Curaray, 20–30 km S of Coca, G. Harling & L. Andersson 11947 (MO). FRENCH GUIANA. Parcelle Arbocel, piste de St. Elie, Km 14, recur après coupe, M. F. Prévost 590 (MO). GUYANA. Potaro–Siparuni region, Chenapou, Amerindian village, Patumona, 50 km upstream from Kaieteur Falls, L. P. Kvist et al. 332 (MO). PERU. **Amazonas:** Bagua Prov., Distr. Imaza, región del Marañon, comunidad de Yamayakat, Río Marañon, R. Vásquez et al. 19329 (MO). **Junín:** Prov. Chanchamayo, rd. from Bajo Pichinaki to Alto Pichinaki, betw. Km 6 and 16, B. A. Stein 2410 (MO). **Loreto:** Prov. Maynas, Mishana, Río Nanay halfway betw. Iquitos and Santa Maria de Nanay, C. Díaz C. et al. 1029 (MO); Prov. Maynas, Puerto Almendras (Centro de Investigación y Enseñanza Forestal [CIEFOR]–Universidad Nacional de la Amazonía Peruana [UNAP]), R. Vásquez & N. Jaramillo 6517 (MO); Aguaitai, R. J. Seibert 2233 (MO). **Madre de Dios:** Río La Torre, 4–15 km upriver from Explorer's Inn, near confluence of Río Tambopata and Río La Torre, 39 km SW of Puerto Maldonado, S. F. Smith et al. 1628 (MO). **Puno:** Ridge betw. Río Candamo and Río Guacamayo, A. H. Gentry et al. 76930 (MO). **San Martín:** Mariscal Cáceres, Tocache Nuevo, trail up Río Huallaga Valley toward Limón, A. H. Gentry et al. 25571 (MO). SURINAME. Tapanahoni R., Kapoea Rapids, H. E. Rombouts 655 (MO). VENEZUELA. **Amazonas:** Alrededores de San Simón de Cocuy, ca. 2–3 km O de Piedra de Cocuy, G. Morillo et al. 4134 (MO); Dep. Atures, virgin rainforest along Río Cataniapo, 44–45 km SE of Puerto Ayacucho, 3 km downstream from dam site, J. A. Steyermark et al. 122158 (MO). **Bolívar:** Reserva Forestal Imataca, carretera Casa Blanca–San Martín de Turumbán (Anacoco), hasta sector Río Cuyuní, B. Stergios et al. 3848 (MO). **Delta Amacuro:** Dep. Tucupita, 5–14 km ESE of Los Castillos de Guayana, G. Davidse & A. C. González 16294 (MO). **Sucre:** Península de Paria, above Las Melenas, N of Río Grande Arriba, SE of Cerro de Humo, J. A. Steyermark & R. Liesner 120938 (MO).

18. *Distictella reticulata* A. H. Gentry, Ann. Missouri Bot. Gard. 65: 728. 1978 [1979]. TYPE: Brazil. Amazonas: Manaus, Igarapé de Cachoeira Alta do Tarumã, 28 Aug. 1962, *W. Rodrigues & J. Chagas 4610* (holotype, INPA not seen; isotype, MO!).

Liana; young branchlets terete, drying dull brown, hollow or solid, pubescent with trichomes weakly ascending; trichomes tan or white, 0.1–0.4 mm; pseudostipules caducous, spatulate, 3.5–5 × 1–2 mm. Leaves bifoliolate or trifoliolate, trifid tendril occasionally present; petiole 6–15 mm, with pubescence like that of branchlets; petiolules 5–15 mm, with pubescence like that of branchlets; leaflets elliptic to ovate, 5–13.5 × 3–8 cm, coriaceous, 4 or 5 pairs of lateral veins, each lateral vein initiating at a 20°–45° angle with the midrib and extending toward apex before anastomosing with the tertiary veins, tertiary veins conspicuous but not distinguishable from the higher order venation, together strongly reticulate and forming a fine, closed network, all veins immersed adaxially and raised abaxially, both surfaces drying brownish green, adaxial surface nearly without trichomes, with a few trichomes at the base along the midrib, scattered lepidote, without glands, abaxial surface with a dense covering of trichomes like those of branchlet or slightly smaller, mainly on venation reticulation and pointing in toward the areoles, abundantly lepidote, without visible glands, margin recurved, base rounded, apex acute to rounded. Inflorescence a raceme or racemose panicle, peduncle with rachis 5–29 cm with 5 to 16 flowers, peduncle 2.5–3.2 mm wide at base, peduncle, rachis, and pedicels drying reddish brown, pubescent with trichomes like branchlets, bracteoles absent or not seen; calyx 10–14 × 10–12 mm, coriaceous, pubescent with dense, tan, strongly appressed trichomes to 0.3 mm, glandular fields 2 pairs; corolla white, infundibular from cylindrical base, curved 1/4–1/3 distance from base, 4.5–6.5 cm, tube 3–4.5 cm with cylindrical base 9–12 mm long and mouth 15–25 mm wide, externally and internally pubescent with minute trichomes above glabrous base, internally slightly glandular-villous at stamen insertion, lobes 15–20 × 15–20 mm; stamens and staminode inserted 12–13 mm from base of corolla tube, anthers 3.5–4.2 mm, longer filaments ca. 22 mm, shorter filaments ca. 18 mm, staminode ca. 4 mm; disc 2–2.5 × 4–4.5 mm; pistil ca. 3.5 cm, ovary ca. 4 × 2 mm, stipe absent, stigma broadly oblong. Capsule elliptic, not curved, ca. 6 × 2.5–2.8 cm, ca. 0.5 cm diam., base acute and truncate, apex acute and apiculate, both valves slightly compressed or sometimes one

very slightly convex and the other slightly concave, drying reddish brown, densely pubescent with minute, appressed, ferruginous trichomes, midrib not evident, wall ca. 1.5 mm thick. Seeds ca. 15 × 35–50 mm, wings poorly demarcated from seed body, reddish brown with tips tan, membranous, hyaline, especially at tips, the veins not contrasting in color to surface.

Distribution. *Distictella reticulata* is known only from Amazonas, Brazil, in the vicinity of Manaus. The elevation was not indicated on the labels; most collections were made along the margins of narrow rivers. Figure 1A.

Phenology. Flowering May to July; fruiting August.

Discussion. The tertiary veins of the leaflets of *Distictella reticulata* cannot be distinguished from the higher order venation and form a strongly raised, very fine reticulation on the abaxial surfaces of the leaflets, similar to that found on the simple leaves of *D. monophylla* and the leaflets of *D. dasytricha*. *Distictella elongata* and *D. obovata* also have a very fine and strongly raised network of veins on the abaxial leaflet surfaces, but usually with the tertiary veins distinct from the higher orders of venation. *Distictella reticulata* is easily distinguished from *D. monophylla*, a shrub with simple leaves, and *D. dasytricha*, which has much longer (1–2 mm) trichomes. *Distictella elongata* differs from *D. reticulata* in its leaflets, which have cuneate to attenuate bases, fruits with an acuminate apex and prominent midrib, and small seeds (8–10 × 25–28 mm). *Distictella obovata* can be separated from *D. reticulata* by its leaflets, which are obovate or oblanceolate with a cuneate base and a glossy adaxial surface, and its fruits, which dry dull black and are quite warty.

Selected specimens examined. BRAZIL. Amazonas: Manaus, margem do igarapé da cachoeira Alta, Estrada Forquilha, *J. Chagas 1705* (K), *1086* (K); Manaus, margem do igarapé do parque 10, *J. Chagas 3994* (K); Manaus, margem do igarapé da cachoeira Alta do Tarumã, *J. Chagas 1330* (K); Manaus, *Francisco & Dionisio 3940* (K).

Literature Cited

- Baillon, H. E. 1891 [1888]. *Histoire des Plantes. Bignoniacées*, Vol. 10: 1–78. L. Hachette et Cie, Paris.
Bentham, G. 1876. Bignoniaceae. Pp. 1026–1053 in G. Bentham & J. D. Hooker (editors), *Genera Plantarum*, Vol. 2(2). Lovell Reeve & Co., Williams & Norgate, London.

- Brawer, M. 1991. Atlas of South America. The MacMillan Press Ltd., London and Basingstoke.
- Bureau, É. 1864. Monographie des Bignoniacées. J.-B. Baillière et Fils, Paris.
- & K. Schumann. 1896. Bignoniaceae. i. Pp. 1–230 in C. F. P. von Martius (editor), *Flora Brasiliensis*, Vol. 8(2, fasc. 118). Lipsiae apud Fried. Fleischer in Comm., Munich.
- Burger, W. & A. H. Gentry. 2000. Bignoniaceae. Pp. 77–162 in W. Burger (editor), *Flora Costaricensis*. Fieldiana, Bot., n.s., Vol. 41.
- Candolle, A. P. de. 1845. Bignoniaceae. Pp. 142–248 in A. L. P. P. de Candolle (editor), *Prodromus*, Vol. 9. Sumptibus Victoris Masson, Paris.
- Funk, V. A. & S. A. Mori. 1989. A bibliography of plant collectors in Bolivia. *Smithsonian Contr. Bot.* 70: i–iii, 1–20.
- Gentry, A. H. 1973 [1974]. Part IX. Family 172. Bignoniaceae. In R. E. Woodson Jr. & R. W. Schery (editors), *Flora of Panama*. *Ann. Missouri Bot. Gard.* 60: 781–977.
- . 1974a. Studies in Bignoniaceae 12: New or noteworthy species of South American Bignoniaceae. *Ann. Missouri Bot. Gard.* 61: 872–885.
- . 1974b. Coevolutionary patterns in Central American Bignoniaceae. *Ann. Missouri Bot. Gard.* 61: 728–759.
- . 1976. Studies in Bignoniaceae 19: Generic mergers and new species of South American Bignoniaceae. *Ann. Missouri Bot. Gard.* 63: 46–80.
- . 1977. Family 178. Bignoniaceae. In G. Harling & B. Sparre (editors), *Flora of Ecuador*. *Opera Bot.* 7: 1–173.
- . 1978a. Bignoniaceae. In B. Maguire (editor), *The Botany of the Guayana Highlands—Part X*. *Mem. New York Bot. Gard.* 29: 245–283.
- . 1978b [1979]. Studies in Bignoniaceae 31: New species and combinations from Amazonian Peru and Brazil. *Ann. Missouri Bot. Gard.* 65: 725–735.
- . 1980a. Studies in Bignoniaceae 37: New species of Bignoniaceae from eastern South America. *Phytologia* 46: 201–215.
- . 1980b. New species of Apocynaceae, Bignoniaceae, Passifloraceae, and Piperaceae from coastal Colombia and Ecuador. *Phytologia* 47: 97–107.
- . 1980c. Bignoniaceae—Part I. *Fl. Neotrop. Monogr.* 25(1): 1–130.
- . 1982. Bignoniaceae. *Flora de Venezuela* 8(4). Fundación de Educación Ambiental, Caracas.
- . 1990. Evolutionary patterns in Neotropical Bignoniaceae. *Mem. New York Bot. Gard.* 55: 118–129.
- . 1992. Six new species of Bignoniaceae from upper Amazonia. *Novon* 2: 159–166.
- . 1997. Bignoniaceae. Pp. 403–491 in P. E. Berry, B. K. Holst & K. Yatskievych (editors), *Flora of the Venezuelan Guayana*, Vol. 3: Araliaceae to Cactaceae. Missouri Botanical Garden Press, St. Louis.
- & A. S. Tomb. 1979 [1980]. Taxonomic implications of Bignoniaceae palynology. *Ann. Missouri Bot. Gard.* 66: 756–777.
- Gomes, J. C., Jr. 1955. Contribuição à sistemática das Bignoniaceae Brasileiras. *Arq. Serv. Florest.* 9: 261–296, pl. 1–4.
- Goodman, E. J. 1972. *The Explorers of South America*. The Macmillan Company, New York, and Collier-Macmillan Limited, London.
- Granville, J.-J. de. 1988. Phytogeographical characteristics of the Guianan forests. *Taxon* 37: 578–594.
- IUCN. 2001. IUCN Red List Categories and Criteria, Version 3.1. Prepared by the IUCN Species Survival Commission. IUCN, Gland, Switzerland, and Cambridge, United Kingdom.
- Janzen, D. H. 1971. Euglossine bees as long-distance pollinators of tropical plants. *Science* 171: 203–205.
- Lohmann, L. G. 2006. Untangling the phylogeny of Neotropical lianas (Bignoniaceae). *Amer. J. Bot.* 93: 304–318.
- & J. R. Pirani. 1998. Flora da Serra do Cipó, Minas Gerais: Bignoniaceae. *Bol. Bot. Univ. São Paulo* 17: 127–153.
- & M. J. G. Hopkins. 1999. Bignoniaceae. Pp. 608–623 in J. E. L. da S. Ribeiro et al. *Flora da Reserva Ducke: Guia de Identificacao das Plantas Vasculares de Uma Floresta de Terra-Firme na Amazonia Central*. INPA-DFID, Manaus.
- Meisner, C. F. 1840. *Plantarum Vascularium Genera*. 9(1-Tab. Diagn.): 285–312, 9(2-Commentarius): 193–224. Libraria Weidmannia, Leipzig.
- Melchior, H. 1927. Der natürliche Formenkreis der *Pithecocteniinae* innerhalb der Familie der Bignoniaceae. *Repert. Spec. Nov. Regni Veg. Beih.* 46: 71–82.
- Orbigny, A. D. d'. 1846. *Voyage dans l'Amérique Méridionale (1826–1833)*, Vol. 3, Part 2 (Géographie). P. Bertrand, Paris.
- Pool, A. 2007. A review of the genus *Distictis* (Bignoniaceae). *Ann. Missouri Bot. Gard.* 94: 791–820.
- Post, T. & O. Kuntze. 1904 [1903]. *Lexicon Generum Phanerogamarum*. Deutsche Verlags-Anstalt, Stuttgart.
- Sampaio, A. J. de. 1935. Novas especies de Bignoniaceas. *Ann. Acad. Brasil. Sci.* 7: 111–127.
- & C. V. Freire. 1936. Duas novas especies Amazonicas de *Distictella* (Bignoniaceas). *Ann. Acad. Brasil. Sci.* 8: 29–32.
- Sandwith, N. Y. 1937. Notes on tropical American Bignoniaceae. *Recueil Trav. Bot. Néerl.* 34: 205–232.
- . 1938a. Bignoniaceae. Pp. 1–86 in A. Pulle (editor), *Flora of Suriname*, Vol. 4(2). J. H. de Bussy Ltd., Amsterdam.
- . 1938b. Notes on unidentified tropical South American Bignoniaceae of Humboldt and Bonpland. *Lilloa* 3: 457–465.
- . 1938c. Three new South American plants. *Brittonia* 3(1): 91–94.
- . 1953 [1954]. Contributions to the flora of tropical America: LVI. Further studies in Bignoniaceae. *Kew Bull.* 1953: 451–484.
- . 1954. Bignoniaceae. Pp. 316–354 in *Flora of Trinidad and Tobago*, Vol. 2. Department of Agriculture, Government Printer, Port-of-Spain.
- . 1957. Bignoniaceae. In B. Maguire & J. J. Wurdack (editors), *The Botany of the Guayana Highlands—Part II*. *Mem. New York Bot. Gard.* 9(3): 359–366.
- . 1962. Contributions to the flora of tropical America: LXVIII. Notes on Bignoniaceae XXVI. *Kew Bull.* 15: 459–466.
- . 1963. Bignoniaceae. In J. A. Steyermark & S. Nilsson (editors), *Botanical Novelties in the Region of Sierra de Lema, Estado Bolivar-2*. *Bol. Soc. Venez. Ci. Nat.* 25(106): 48–49.
- . 1965. Contributions to the flora of tropical America: LXXII. Notes on Bignoniaceae: XXVIII. The identity of *Anemopaegma nigrescens*. *Kew Bull.* 19: 409–414.

- . 1968. Contributions to the flora of tropical America: LXXVI. Notes on Bignoniaceae: XXIX. *Arrabidaea* in Martius's 'Flora Brasiliensis' and subsequently. Kew Bull. 22: 403–420.
- Santos, G. dos. 1995. Wood Anatomy, Chloroplast DNA, and Flavonoids of the Tribe Bignoniaceae (Bignoniaceae). Ph.D. Thesis, The University of Reading, Reading, United Kingdom.
- Schultes, R. E. 1970. De plantis toxicariis e Mundo Novo tropicale commentationes VII. Several ethnotoxicological notes from the Colombian Amazon. Bot. Mus. Leaflet. 22: 345–352.
- Schumann, K. 1894 [1894–1895]. Bignoniaceae. Pp. 189–252 in A. Engler (editor), Die Natürlichen Pflanzenfamilien, Vol. 4(3b). Wilhelm Engelmann, Leipzig.
- Sprague, T. A. 1911. *Arrabidaea crassa*. Hooker's Icon. Pl. 30: t. 2933.
- & N. Y. Sandwith. 1932. Contributions to the flora of tropical America: X. New and noteworthy Bignoniaceae from British Guiana, mainly collected by the Oxford University Expedition, 1929. Bull. Misc. Inform. Kew 1932: 81–93.
- Urban, I. 1916a. Bignoniaceae trinitensis, nonnullis aliis antillanis novis adjectis. Repert. Spec. Nov. Regni Veg. 14: 300–314.
- . 1916b. Über Ranken und Pollen der Bignoniaceen. Ber. Deutsch. Bot. Ges. 34: 728–758, tab. 21.
- Verlot, B. 1868. Bignoniacees Brésiliennes nouvelles. Rev. Hort. 40: 152–154.

APPENDIX I. Index to Numbered Exsiccatae.

Collections are listed alphabetically by collector and collection number with each collection number followed by a species number in parentheses. The index includes all specimens entered into Tropicos that were identified to species by A. Pool and are without qualifiers (aff., cf., or “?”), excluding those records lacking collector name. Boldface indicates type collections.

LIST OF SPECIES

1. *Distictella arenaria* A. H. Gentry
 2. *Distictella campinae* A. Samp.
 3. *Distictella chocoensis* A. H. Gentry
 4. *Distictella cremersii* A. H. Gentry
 5. *Distictella cuneifolia* (DC.) Sandwith
 6. *Distictella dasytricha* Sandwith
 7. *Distictella elongata* (Vahl) Urb.
 8. *Distictella laevis* (Sandwith) A. H. Gentry
 9. *Distictella lohmanniae* A. Pool
 10. *Distictella magnoliifolia* (Kunth) Sandwith
 11. *Distictella mansoana* (DC.) Urb.
 12. *Distictella monophylla* Sandwith
 13. *Distictella obovata* Sandwith
 14. *Distictella parkeri* (DC.) Sprague & Sandwith
 15. *Distictella pauciflora* A. H. Gentry
 16. *Distictella porphyrotricha* Sandwith
 - 17a. *Distictella racemosa* (Bureau & K. Schum.) Urb. var. *racemosa*
 - 17b. *Distictella racemosa* var. *translucida* A. Pool
 18. *Distictella reticulata* A. H. Gentry
- Allen, P. H. 3210 (10). Alvarenga, D. & E. Curado Lopes 239 (11). Alvarenga, D. & F. M. Paixão 651 (11). Alvarenga, M. s.n. (INPA 120328) (8). Amaral, I. L. et al. 545 (17a), 932

- (8), 935 (8). Amaral, M. C. et al. 7151 (11). Anderson, W. R. 10539 (8), 10928 (8), 11965 (11). Anderson, W. R. et al. 6555 (11), 8273 (11), 8798 (11), 10216 (11), 10945 (11), 10999 (17a). Aparecida da Silva, M. & D. Alvarenga 933 (11). Aparecida da Silva, M. & C. C. S. Ferreira 3111 (11). Aquilante, D. 6 (11). Arbo, M. M. et al. 4878 (11), 4999 (11). Aronson, J. & F. Rodrigues V. 861 (17b). Ayala, F. 257 (17a). Ayala, F. et al. 3366 (17a). Aymard, G. 7993 (17a). Aymard, G. & L. Delgado 8383 (12). Aymard, G. et al. 4057 (17b). Azevedo, M. L. M. et al. 215 (11).
- Barreto, K. D. et al. 1948 (11), 2354 (11), 3431 (11). Beck, S. G. 4941 (11), 20589 (5). Beck, S. G. & R. Haase 10003 (11), 10132 (17a). Berry, P. E. 1382 (10), 1426 (10), 1426-a (10), 1496 (10). Berry, P. E. & E. Melgueiro 5315 (12). Berry, P. E. et al. 6026 (12), 6173 (12), 6250 (12), 6542 (12), 6549 (12). Besse, L. et al. 1794 (11). Bilby, R. et al. 339 (2). Billiet, F. & B. Jadin 1604 (17a), 2037 (17a), 5762 (7), 6394 (17b). Black, G. et al. 57-19576 (7). Bonpland, A. **973 (10)**, s.n. (10). Broadway, W. E. **4753 (17b)**.
- Calderon, C. E. et al. 2703 (8). Cardenas L., D. et al. 2940 (17b). Cardiel, J. M. et al. CHIN-292 (17b). Castillo, A. 4292 (17a), 4995 (17a), 5308 (17a), 6995 (17a). Castillo, A. et al. 3502 (1). Chagas, J. 1086 (18), 1330 (18), 1705 (18), 3994 (18). Cid Ferreira, C. A. 5808 (8), 8868 (17b). Cid Ferreira, C. A. & J. Lima 3630 (17a). Cid Ferreira, C. A. et al. 497 (2), 820 (17a), 1264 (7), 1389 (17a), 2210 (17a), 4307 (11), 4446 (11), 5219 (17b), 8664 (2). Cogollo, A. & C. Estrada 200 (17b). Cogollo, A. et al. 4590 (17b). Coradin, L. & M. R. Cordeiro 1083 (10). Cordeiro, I. s.n. (CFCR653) (11). Correa de Mélo, J. 13 (11). Costa, F. N. et al. 149 (11). Cremers, G. **4589 (4)**, 5281 (17b), 8377 (14), 9528 (7). Cremers, G. & J.-J. de Granville 14427 (7). Cremers, G. & M. Hoff 11311 (17b), 11344 (17b). Cremers, G. et al. 12507 (14). Croat, T. B. 19905 (17a), 20049 (17b). Cruz, J. S. de la 2734 (14).
- Daly, D. C. et al. 993 (2). Damião, C. 3001 (17a), 3089 (17a). Davidse, G. & A. C. González 16294 (17b). G. Davidse et al. 17568 (2). Davidson, C. & J. Revilla 5370 (17a). Davis, E. W. 140-a (1). Díaz C., C. & H. Osoreo 662 (17a). Díaz C., C. et al. 236 (17a), 605 (17a), 1029 (17b). Dodson, C. H. & J. Torres 2940 (17b). Ducke, A. **8022 (17a)**, **8022-a (17a)**, s.n. (**RB 22688**) (2). Dulmen, A. van & N. Matapi 42 (17a).
- Eiten, G. et al. 5797 (11), 5813 (11), 6013 (11). Encarnacion, F. 80 (17a). Evans, R. & G. Lewis 1869 (4).
- Ferrucci, S. 793 (11). Feuillet, C. 1588 (7). Fosberg, F. R. 43323 (11). Foster, P. F. et al. 528 (11). Francisco & Dionisio 3940 (18). Freitas, M. A. et al. 469 (9).
- Gentry, A. H. 12747 (17a), 12969 (10), 12976 (9), 13062 (17a). Gentry, A. H. & P. Berry **14615 (1)**, 14618 (1), 14633 (1). Gentry, A. H. & D. Daly 18322 (17a). Gentry, A. H. & C. Díaz S. 28199 (17b), 28225 (6), 28234 (6). Gentry, A. H. & M. Fallen 17815 (17b). Gentry, A. H. & R. Foster 70871 (11). Gentry, A. H. & C. Feuillet 63205 (7). Gentry, A. H. & N. Jaramillo 57925 (17b). Gentry, A. H. & P. Núñez 69446 (11), 69789 (11). Gentry, A. H. & R. Ortiz 74243 (17a). Gentry, A. H. & A. Pinheiro 13130 (2). Gentry, A. H. & G. Prance 11217 (10). Gentry, A. H. & J. Ramos 13067 (17a). Gentry, A. H. & E. Renteria A. **24089 (3)**. Gentry, A. H. & J. Revilla 20493 (17a), 20825 (17a). Gentry, A. H. & B. Stein 46381 (10), 46685 (17a), 47159 (17a). Gentry, A. H. & S. Tillett 10874 (1), 10900 (10). Gentry, A. H. & K. Young 32010 (17b). Gentry, A. H. & Elsa Zardini 50256 (14), 50342 (7). Gentry, A. H. et al. 9076 (17b), 10484 (13), 10565 (16), 10566 (13), 10571 (16), 10660 (14), 15637 (17b), 15844 (17a), 18557 (17a), 20335 (17a), 21293 (17a), 25571 (17b), 42096 (17b), 44250 (11), 44335 (11), 45995

Walter, B. M. T. *et al.* 621 (11). Williams, L. 15309 (17a).
Woytkowski, F. 5140 (17a), 5158 (17a). Wulschlaegel, H. R.
1033 (17a). Wurdack, J. J. & L. S. Adderley 43008 (17a).
Yanagizawa, Y. *s.n.* (SP8981) (11), *s.n.* (SP8982) (11).
Zarucchi, J. L. 1293 (17a), 2109 (17a). Zarucchi, J. L. &
C. E. Barbosa 3437-a (1). Zarucchi, J. L. & R. E. Schultes
1027 (17a). Zarucchi, J. L. *et al.* 2600 (8), 3010 (17a), 3173
(17a).

A REVISION OF MALAGASY *GNIDIA* (THYMELAEACEAE, THYMELAEOIDEAE)¹

Zachary S. Rogers²

ABSTRACT

A systematic revision of *Gnidia* L. is presented based on an analysis of morphological data. The circumscription of the genus adopted here includes *Lasiosiphon* Fresen. and excludes *Atemnosiphon* Leandri and *Dais* L. Six new combinations are made for species previously recognized as *Lasiosiphon*: *G. ambondrombensis* (Boiteau) Z. S. Rogers, *G. hibbertioides* (S. Moore) Z. S. Rogers, *G. humbertii* (Leandri) Z. S. Rogers, *G. linearis* (Leandri) Z. S. Rogers, *G. occidentalis* (Leandri) Z. S. Rogers, and *G. perrieri* (Leandri) Z. S. Rogers. Two names, *G. daphnifolia* L. f. and *G. linearis*, are resurrected from synonymy with *L. madagascariensis* (Lam.) Decne. and *L. decaryi* Leandri, respectively, and now pertain to more broadly circumscribed species. One new species, *G. neglecta* Z. S. Rogers, is described. These changes result in the recognition of 14 species, all endemic, making *Gnidia* the largest genus of Malagasy Thymelaeaceae. Lectotypifications are provided for 15 names: *Dais gnidioides* Baker, *G. danguyana* Leandri, *L. bojerianus* Decne., *L. decaryi*, *L. decaryi* var. *erectus* Leandri, *L. decaryi* var. *littoralis* Leandri, *L. decaryi* var. *tenerifolia* Leandri, *L. dumetorum* Leandri, *L. hildebrandtii* Scott-Elliot, *L. humbertii* Leandri, *L. madagascariensis* var. *angustifolius* Leandri, *L. madagascariensis* var. *mandrarenensis* Leandri, *L. occidentalis* Leandri, *L. perrieri* Leandri, and *L. pubescens* (Lam.) Decne. var. *multifolius* Leandri. Each species is illustrated, mapped, and assigned a preliminary IUCN conservation status.

RÉSUMÉ

Le genre *Gnidia* L. est révisé sur la base d'une analyse de données morphologiques. Le genre est traité ici en incluant *Lasiosiphon* Fresen. mais en excluant *Atemnosiphon* Leandri et *Dais* L. Six nouvelles combinaisons sont effectuées pour des espèces déjà reconnues comme *Lasiosiphon*: *Gnidia ambondrombensis* (Boiteau) Z. S. Rogers, *G. hibbertioides* (S. Moore) Z. S. Rogers, *G. humbertii* (Leandri) Z. S. Rogers, *G. linearis* (Leandri) Z. S. Rogers, *G. occidentalis* (Leandri) Z. S. Rogers, et *G. perrieri* (Leandri) Z. S. Rogers. Deux noms, *G. daphnifolia* L. f. et *G. linearis*, sont retirés de la synonymie sous *L. madagascariensis* (Lam.) Decne. et *L. decaryi* Leandri, respectivement, et ils concernent désormais deux espèces plus largement circonscrites. Une espèce nouvelle, *G. neglecta* Z. S. Rogers, est décrite. De ces changements résulte la reconnaissance de 14 espèces, toutes endémiques, rendant *Gnidia* le plus grand genre de Thymelaeaceae à Madagascar. Des lectotypifications sont donnés pour 15 noms: *Dais gnidioides* Baker, *G. danguyana* Leandri, *L. bojerianus* Decne., *L. decaryi*, *L. decaryi* var. *erectus* Leandri, *L. decaryi* var. *littoralis* Leandri, *L. decaryi* var. *tenerifolia* Leandri, *L. dumetorum* Leandri, *L. hildebrandtii* Scott-Elliot, *L. humbertii* Leandri, *L. madagascariensis* var. *angustifolius* Leandri, *L. madagascariensis* var. *mandrarenensis* Leandri, *L. occidentalis* Leandri, *L. perrieri* Leandri, et *L. pubescens* (Lam.) Decne. var. *multifolius* Leandri. Chaque espèce est illustrée, cartographiée et assignée à un statut de conservation provisoire de l'IUCN.

Key words: Africa, *Atemnosiphon*, *Gnidia*, IUCN Red List, *Lasiosiphon*, Madagascar, Thymelaeaceae, Thymelaeoideae.

Gnidia L. (ca. 140–160 species; Herber, 2003; Peterson, 2006) is the largest genus in the Thymelaeaceae, belongs to the largest subfamily Thymelaeoideae, and is almost completely restricted to Africa and Madagascar. More than 100 species occur in South Africa's Western Cape Province alone (Beaumont et al., 2001a; Bredenkamp & Beyers, 2003), and a single widespread species, *G. glauca*

(Fresen.) Gilg, reaches as far east as Arabia, India, and Sri Lanka (Townsend, 1981; Herber, 2003; Peterson, 2006). *Gnidia* was last revised in its entirety by Meisner (1857), but several significant regional treatments have been published in the important African floras of the last century (Pearson, 1910; Wright, 1915; Staner, 1935; Aymonin, 1966a, b; Gastaldo, 1969; Robyns, 1975; Peterson, 1978). The

¹The author thanks the curators and support staff of the following herbaria for providing loan material: A, B, BM, BR, F, G, GH, K, MA, MO, NY, P, TAN, TEF, US, WAG. A number of other people should be acknowledged for their various contributions: S. Andriambololona and J. Raharimampionona entered specimen data; F. Rakotonasolo and R. Razakamalala assisted with fieldwork; G. Schatz, M. Merello, G. McPherson, and P. Phillipson provided helpful comments on early drafts of the manuscript; M. Spencer assisted with the typification of the Linnaean names; L. Andriamiarisoa provided the illustrations; P. Stevens translated the diagnosis into Latin; V. Malécot and M. Callmender helped with the French abstract; B. Rye and one anonymous reviewer provided the reviews. The 2003 fieldwork was supported by the John Denver Memorial Scholarship granted from the International Center for Tropical Ecology at the University of Missouri–St. Louis. Funding for the 2006 fieldwork came from the Botanical Research Institute of Idaho.

²Missouri Botanical Garden, P.O. Box 299, St. Louis, Missouri 63166-0299, U.S.A. zachary.rogers@mobot.org.
doi: 10.3417/2006114

genus was last treated for Madagascar by Leandri (1950) in the *Flore du Madagascar et des Comores*. Generic delimitation of *Gnidia* and putative relatives has proven to be particularly problematic due to the considerable morphological variation in the characters that define the groups (see also Peterson, 1959; Aymonin, 1965; Rogers, 2006). A preliminary molecular study (Van der Bank et al., 2002) based on *rbcL* and *trnL-F* data suggests that the genus is paraphyletic, but additional genes and much broader sampling are needed before the taxonomic circumscription of *Gnidia* can be adequately addressed using molecular data.

Domke (1934), in the most comprehensive morphological classification of Thymelaeaceae to date, placed *Gnidia* in subtribe Gnidiinae of tribe Gnidieae, along with six other African genera: *Craspedostoma* Domke, *Cryptadenia* Meisn., *Dais* L., *Lachnaea* L., *Lasiosiphon* Fresen., and *Struthiola* L. Tribal and generic limits have been defined traditionally by unique combinations of floral characters and, in some groups, supplemented by secondary leaf, bract, inflorescence, and fruit features (Meisner, 1857; Baillon, 1875; Gilg, 1894; Domke, 1934). Herber (2003), the first author to exhaustively update Domke's generic classification, recognized four informally ranked groups, i.e., the Daphne, *Gnidia*, *Linostoma*, and *Phaleria* groups, each one corresponding roughly to one of the four tribes of Thymelaeoideae recognized by Domke (1934). The *Gnidia* group is defined by an articulated hypanthium, a lateral style, and a seed with endosperm and relatively thin cotyledons. Several exceptions in these diagnostic character states are known to exist for some of the genera in the group, e.g., the hypanthium is reportedly rarely unarticulated in *Dais* (Peterson, 2006) and lacking in *Kelleria* Endl. (Heads, 1990), *Atemnosiphon* Leandri, and two species of *Gnidia* (Rogers, pers. obs.), and the style is terminal in *Drapetes* Banks ex Lam. (Heads, 1990). *Gnidia* is distinguished from other members within the *Gnidia* group by its eight or 10 included or only slightly exerted stamens, the sepals noticeably shorter than the tube, sessile or subsessile anthers, the petaloid scales (when present) borne near the mouth of the articulated hypanthium, and by the relatively small or absent disk surrounding the base of the ovary (Herber, 2003).

Historically, the overlapping and inconsistent variation in the diagnostic characters of *Gnidia* led to the description of several segregate genera, namely *Lasiosiphon* (1838), *Arthrosolen* C. A. Mey. (1843), *Gnidiopsis* Tiegh. (1893), *Rhytidosolen* Tiegh. (1893), *Englerodaphne* Gilg (1894), *Craspedostoma* (1934), *Basutica* E. Phillips (1944), *Pseudognidia* E. Phillips (1944), *Struthiolopsis* E. Phillips (1944), and *Atemno-*

siphon (1947). Most segregates were reduced to synonymy with *Gnidia* shortly after their publication without much controversy except for two genera, *Lasiosiphon* and *Atemnosiphon*. *Lasiosiphon*, originally segregated because of its 5- rather than 4-merous flowers, was maintained through the first half of the 20th century in African floras (e.g., Pearson, 1910; Wright, 1915) and in the most important morphological classification (Domke, 1934). Leandri (1950) in the *Flore des Madagascar des Comores* was probably the last author to uphold *Lasiosiphon* as a distinct genus, recognizing 15 species of *Lasiosiphon* and four species of *Gnidia* from Madagascar (neither genus recorded for the Comoro Islands). Peterson (1959) argued strongly to synonymize *Lasiosiphon* with *Gnidia*, a position based mainly on his observations of the morphological inconsistencies in the floral merosity of several African species, and his view has been followed by subsequent authors (for a review, see also Rogers, 2006). *Atemnosiphon*, the newest published segregate (Leandri, 1947), includes a single endemic Malagasy species (originally described in *Lasiosiphon* as *L. coriaceus* Leandri) and was only recently placed into synonymy with *Gnidia* by Herber (2003). *Atemnosiphon* does not fit very well within Herber's circumscription of *Gnidia* because of its distinctly exerted filaments and overall uncharacteristic appearance, e.g., leaves with a marginal vein, unarticulated hypanthium with a relatively large subgynoecial disk, and fruit that splits laterally through the side of the hypanthium during development. Aymonin (1965) noted similarities between *Atemnosiphon* and the widespread *G. glauca*, and the two do indeed share a similar inflorescence structure and lack an articulated hypanthium. Unfortunately, *Atemnosiphon* and *G. glauca* were not sampled in the molecular phylogeny of Van der Bank et al. (2002).

One other genus of Herber's *Gnidia* group occurs in Madagascar (*Dais*, one African and one Malagasy species). Unlike *Lasiosiphon* and *Atemnosiphon*, however, *Dais* has always been retained as a distinct genus. The African species, *D. cotinifolia* L., was included in the molecular phylogeny of Van der Bank et al. (2002) and formed a clade with *Phaleria capitata* Jack (99% bootstrap support), but the position of the clade was unresolved within a larger clade consisting of nearly all of the other sampled species of Thymelaeoideae. *Phaleria* Jack (25–30 species, Sri Lanka to Polynesia, Australia, and the Samoan Islands; Rye, 1990) was placed in subtribe Phalerieae (sensu Domke, 1934) and later in the *Phaleria* group (sensu Herber, 2003) because of the substantial morphological differences with *Dais*. Specifically, *Phaleria* differs from *Dais* by having a 2- versus 1-locular gynoecium, a terminal versus

lateral style, and a fibrous versus membranous or fleshy pericarp. Morphology suggests that *Dais* is more closely allied with *Gnidia* than *Phaleria*, but *Dais* can still be separated easily from *Gnidia* by the same androecial characters that separate *Atemnosiphon* from *Gnidia*. Given the unresolved phylogeny of the *Gnidia* group (Van der Bank et al., 2002; Rautenbach & Van der Bank, unpubl. data), the circumscription of *Gnidia* adopted for this revision includes *Lasiosiphon* and provisionally excludes *Atemnosiphon* and *Dais*.

Since the publication of the *Flore de Madagascar et des Comores* (Leandri, 1950), many new herbarium collections of *Gnidia* are now accessible, which, along with recent field observations, permit a reevaluation of the taxonomy of the Malagasy members of the genus. All taxa previously recognized by Leandri (1950) as *Lasiosiphon* are treated here as species of *Gnidia*, thus six new combination names are required. Aymonin (1962, 1965) previously indicated that several Malagasy names of *Lasiosiphon* should be treated as *Gnidia*, but his statements cannot be regarded as valid transfers according to Article 33.4 of the *International Code of Botanical Nomenclature* (McNeill et al., 2006) because he did not provide full and direct references to the basionyms. A broader circumscription is adopted below for two geographically widespread and morphologically variable species, *G. daphnifolia* L. f. and *G. linearis* (Leandri) Z. S. Rogers, which Leandri (1950) previously recognized by the names *L. madagascariensis* (Lam.) Decne. and *L. decaryi* Leandri, respectively. One new species, *G. neglecta* Z. S. Rogers, is described. These changes result in the recognition of 14 species (Appendix 1), all endemic, making *Gnidia* the largest Malagasy genus of Thymelaeaceae.

Besides *Gnidia*, *Atemnosiphon*, and *Dais*, there are four additional genera and 15 species of Thymelaeaceae occurring on Madagascar and in the adjacent Comoro Island archipelago: *Peddiea* Harv. ex Hook. (ca. 11 species: one Malagasy and ca. 10 African), *Octolepis* Oliv. (six species: five Malagasy and one African; Rogers, 2005), *Stephanodaphne* Baill. (nine species: eight Malagasy and one Comorian; Rogers, 2004), and *Synaptolepis* Oliv. (six species: one Malagasy and about five African).

MATERIALS AND METHODS

Herbarium specimens of ca. 530 collections (Appendix 2) were examined from the following institutions: A, B, BM, BR, F, G, GH, K, LINN, MA, MO, NY, P, TAN, TEF, US, and WAG. Specimens and pickled material were collected by the author for eight of the 14 species recognized here during four collecting trips to Madagascar (January–

March 2003, March–July 2004, January–February 2006, and November 2006). Field trips were planned so that plants from as many populations as possible could be observed and sampled. Populations of *Gnidia* occurring in the northwestern and far western regions of the island were unable to be reached due to logistical constraints.

The species concept and criteria follow those discussed in Rogers (2004). No infraspecific taxa are recognized. All examined specimens were databased and are available on the Missouri Botanical Garden's Tropicos website (<<http://www.tropicos.org/>>) along with images of types and representative herbarium vouchers. Geographic coordinates and elevations were assigned, whenever possible, using the *Gazetteer to Malagasy Botanical Collecting Localities* (Schatz & Lescot, 2009). Full specimen data including post-facto coordinates and elevations are available from the author by request. Species distributions are mapped over the outlines of the five simplified bioclimatic zones of Madagascar as discussed in Schatz (2000; following Cornet, 1974). Maps were created using ArcGIS 9 software (ESRI, Redlands, California, U.S.A.).

A summary of all names treated in the taxonomic section is provided in Appendix 3.

MORPHOLOGICAL CHARACTERS AND VARIATION IN MALAGASY *GNIDIA*

HABIT

The majority of species are erect, weakly to densely branched, shrubs or treelets from 1–2 m tall. The habit of a few species (e.g., *Gnidia daphnifolia*, *G. linearis*) can vary greatly, some individuals being small weakly branched shrubs, while others becoming trees up to 6 m tall with a diameter of 25 cm at breast height. *Gnidia humbertii* (Leandri) Z. S. Rogers differs from other Malagasy species by its rounded, densely branched habit, which rarely reaches 60 cm in height, and also has a well-developed underground root system that probably links nearby plants (presumably clones). Some species (e.g., *G. danguyana* Leandri, *G. linearis*) are reported to resprout from a common rootstock, allowing them to survive local harvesting and the periodic burning (M. Madeleine & R. Ramiandrisoa, pers. comm.). It is quite evident that some populations of *G. daphnifolia* remain small and shrubby only because of frequent burning. Specimens from one particularly stunted individual served as the basis for the name *Lasiosiphon suffrutescens* Leandri (1947). Most species, at 1 m tall, have a single primary root with several smaller secondary roots, each one possessing a few to many thin, fibrous roots.

Malagasy species generally exhibit some form of sympodial growth. Many species have obvious equal or subequal dichotomous branching. *Gnidia gnidioides* (Baker) Domke (Fig. 7A) is the only species known to possess a distinctive branching pattern composed of trichotomous orthotropic shoots that was discussed by Hallé et al. (1978) and referred to in that work by the illegitimate name "*Gnidia bakeri* Gilg." The same branching pattern occurs in two closely related African species, *G. bambutana* Gilg & Ledermann ex Engl. and *G. mollis* C. H. Wright, and the architecture of all three was carefully studied and described in detail in Aymonin (1966c).

Most species have spiral phyllotaxy. *Gnidia decaryana* Leandri (Fig. 5A) and *G. neglecta* (Fig. 11A) differ markedly by their opposite to decussate leaves, but leaves on vigorous shoots may sometimes be subopposite or more rarely alternate. Internode length, while quite variable in most species, is so short in *G. ambondrombensis* (Boiteau) Z. S. Rogers (Fig. 1A) and *G. humberitii* (Fig. 9A) that adjacent leaf bases slightly overlap along most of the stem. In both species, as well as *G. razakamalalana* Z. S. Rogers (Fig. 14), branches are covered by conspicuous leaf scars.

As in all Thymelaeaceae, the bark of *Gnidia* is strong and fibrous, and in Malagasy *Gnidia*, it is usually longitudinally striate on younger branches. Bark on older branches of *G. ambondrombensis* and often *G. humberitii* frequently exfoliates. Most species have gray, brown, or black bark. *Gnidia neglecta* and *G. razakamalalana* have dark red bark. In *G. perrieri* (Leandri) Z. S. Rogers, bark on the young branches dries a characteristic red-purple or orange-red. Lenticels are densely arranged on the bark of *G. danguyana*, *G. decaryana*, *G. bojeriana* (Decne.) Gilg, and *G. perrieri*, whereas the lenticels are more sparsely spaced (when present) on the bark of *G. daphnifolia*, *G. linearis*, and *G. occidentalis* (Leandri) Z. S. Rogers.

INDUMENT

Trichomes are unicellular, unbranched, short, silver-colored, and generally appressed. Indument presence or absence, density, type, position, and length are taxonomically important characters. Specific patterns of variation present on particular organs are discussed in subsequent sections.

LEAVES

Leaf shape is most often obovate or elliptic. *Gnidia gnidioides* (Fig. 7A) and some populations of *G. linearis* (Fig. 10B) have small needle-shaped leaves,

which are also prevalent in continental African species of the genus (e.g., *G. mollis*, *G. pinifolia* L.). The blades of some species with larger obovate leaves are often asymmetrical (e.g., *G. daphnifolia*, *G. gilbertae* Drake, and *G. occidentalis*).

For a few species, the size and, to a lesser degree, the shape, of leaves may vary substantially between individuals growing in the same population, and even between leaves on the same branch (e.g., *Gnidia daphnifolia*). Beaumont et al. (2001a) conducted a morphometric investigation of 18 *Gnidia* species exhibiting a wide range of variation in leaves (and bracts), including two Malagasy species, *G. danguyana* and *G. daphnifolia* (as "*G. madagascariensis* var. *baronii*," sic), and found that the length to width (l:w) ratio of leaves and bracts are taxonomically important characters, and that the l:w ratios of the leaves compared to the bracts are not correlated. Their results (Beaumont et al., 2001a, b) can be extended to include all of the other bracteate Malagasy species. Leaf l:w ratios are more consistent and taxonomically useful than linear size measurements in some species, e.g., *G. daphnifolia* (Fig. 4A–C) versus *G. occidentalis* (Fig. 12A, B). The largest leaf l:w ratios reach 14–15:1 in *G. gnidioides* (Fig. 7A) and *G. linearis* (Fig. 10A).

In live plants and sometimes on dry material of *Gnidia decaryana*, the leaves are appressed adaxially against the stems, thereby concealing most, if not all, of the sessile or subsessile few-flowered inflorescences (Fig. 5A). For most species, leaves are generally persistent along most of the branch on a typical herbarium specimen, but only the leaves located ca. 1–2(–3) cm from the branch tips remain persistent in *G. ambondrombensis* (Fig. 1A) and usually in *G. gilbertae* (Fig. 6A) and *G. humberitii* (Fig. 9A). Leaf texture is generally chartaceous to coriaceous. Leaves, when dry or fresh, are usually darker in color adaxially. The abaxial blade surfaces of *G. neglecta* and *G. perrieri* are often glaucous, at least after drying. Leaves are shortly petiolate or sessile, but this distinction becomes blurred in species with long-attenuate leaf bases.

Most species have at least some trichomes on their leaves, at least initially. Leaves (and stems) are completely glabrous in four species: *Gnidia danguyana*, *G. decaryana*, *G. neglecta*, and *G. perrieri*. Trichomes on leaves are generally appressed. The subappressed trichomes of *G. hiberitoides* (S. Moore) Z. S. Rogers (Fig. 8A) may simply be a drying artifact present on the only known specimen of the species. Leaves of some species, e.g., *G. bojeriana* (Fig. 2A), *G. gilbertae* (Fig. 6A), and sometimes *G. daphnifolia* (Fig. 4D), may have many persistent trichomes remaining on both surfaces of the blade. In these

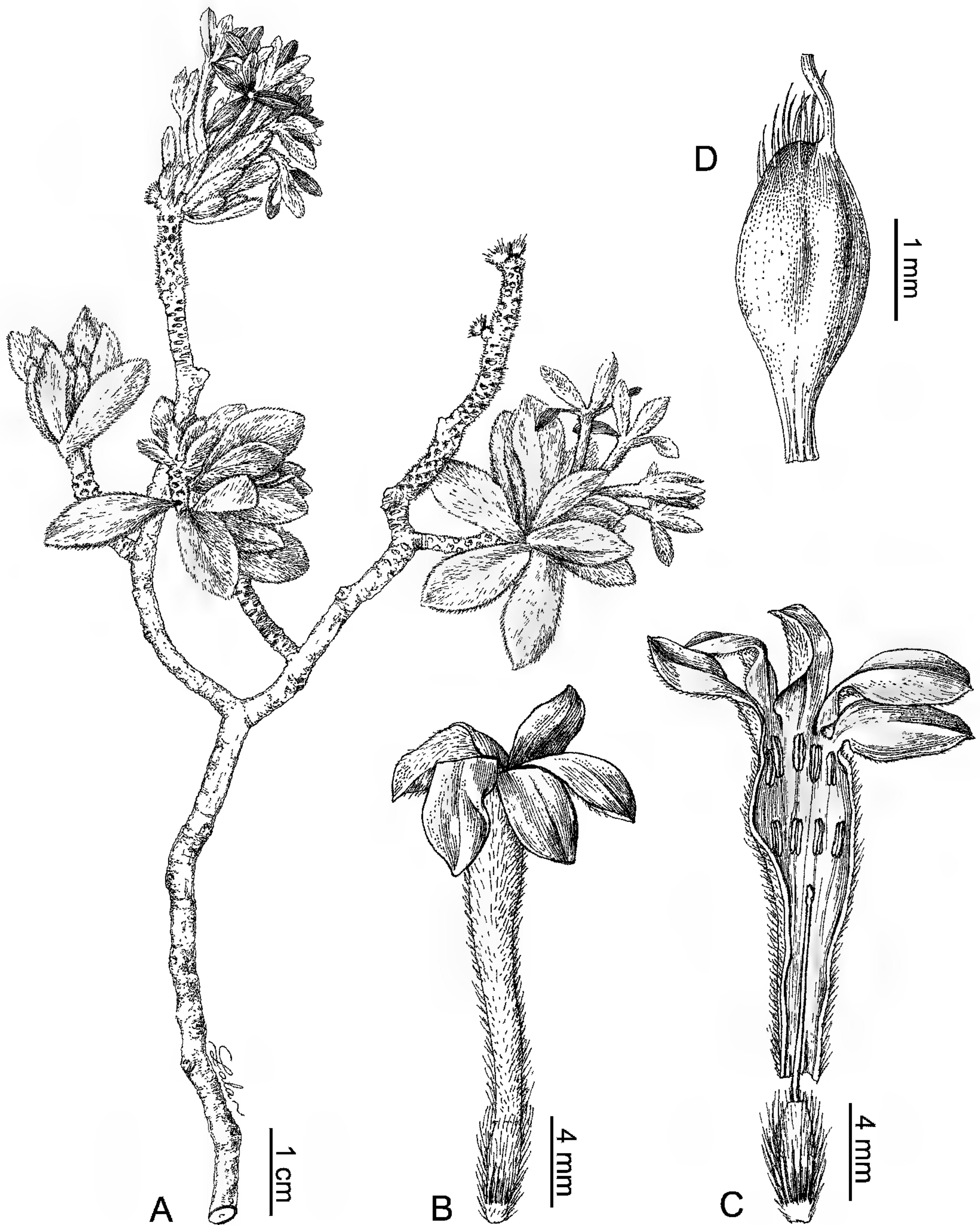

Figure 1. *Gnidia ambondrombensis* (Boiteau) Z. S. Rogers. —A. Habit. —B, C. Flower. —D. Gynoecium. Habit and gynoecium drawn from isotype, Boiteau (*Hb. Jard. Bot. Tananarive*) 4643 (TAN). Flower drawn from Rogers & Rakotonasolo 706 (MO).

cases, however, the trichomes are faint and imperceptible by the unaided eye, and the indument does not generally obscure the leaf surface and venation pattern, at least not adaxially. Alternatively, the sericeous indument remains so dense on both leaf surfaces in *G. ambondrombensis* (Fig. 1A) and *G.*

humbertii (Fig. 9A), and on the abaxial leaf surface of *G. razakamalalana* (Fig. 14B) and rarely *G. daphniifolia* (Fig. 4D), that the surface and venation pattern remain completely hidden. Leaf trichomes of *G. humbertii* are generally matted and ca. 0.3 mm long, whereas those of *G. ambondrombensis*, *G. razakama-*



Figure 2. *Gnidia bojeriana* (Decne.) Gilg. —A. Habit. —B, C. Flower. Habit drawn from Rogers & Randrianaivo 175 (MO). Flower drawn from Rogers & Randrianaivo 183 (MO).

lalana, and *G. daphnifolia* are straight and exceed 1 mm in length.

Leaf bases are usually cuneate to attenuate and decurrent along the petiole, but the bases of *Gnidia danguyana* (Fig. 3A) and *G. neglecta* (Fig. 11B) are at least slightly cordate. Within a species, leaf apices vary from obtuse to acute and the tips are usually

rounded or mucronate. Leaf margins are entire, a family characteristic, but may vary between flat to somewhat revolute, the latter character state occurring more frequently on wider leaves and especially near the base of the blade.

Most Malagasy species of *Gnidia* exhibit some form of brochidodromous venation. The venation pattern



Figure 3. *Gnidia danguyana* Leandri. —A. Habit. —B, C. Flower. Drawn from Rogers *et al.* 76 (MO).

consists of one, or sometimes two, submarginal loops interconnected with an anastomosing network near the margin (e.g., *G. danguyana*, Fig. 3A), or of strongly arcuate secondaries meeting the margin in the upper 1/4 to 1/2 of the blade (e.g., *G. daphnifolia*, Fig. 4B), or by a pattern only represented on the abaxial surface by a midrib and two or four longitudinal plicate veins (*G. gnidioides*, Fig. 7A). Most species have concolorous venation compared to the blade. Fine venation anastomoses in an irregular pattern when visible. Generally, venation is slightly raised and more prominently so abaxially.

INFLORESCENCES

Species with opposite or decussate phyllotaxy (e.g., *Gnidia decaryana*) consistently have terminal inflorescences, whereas species with spiral phyllotaxy have axillary or pseudoterminal inflorescences, the latter condition being the most pronounced when branch internodes are short. In a few pedunculate species (e.g., *G. danguyana*, sometimes *G. daphnifolia*), the inflorescence can be extra-axillary with the peduncle being carried several millimeters above its axil as the stem develops.

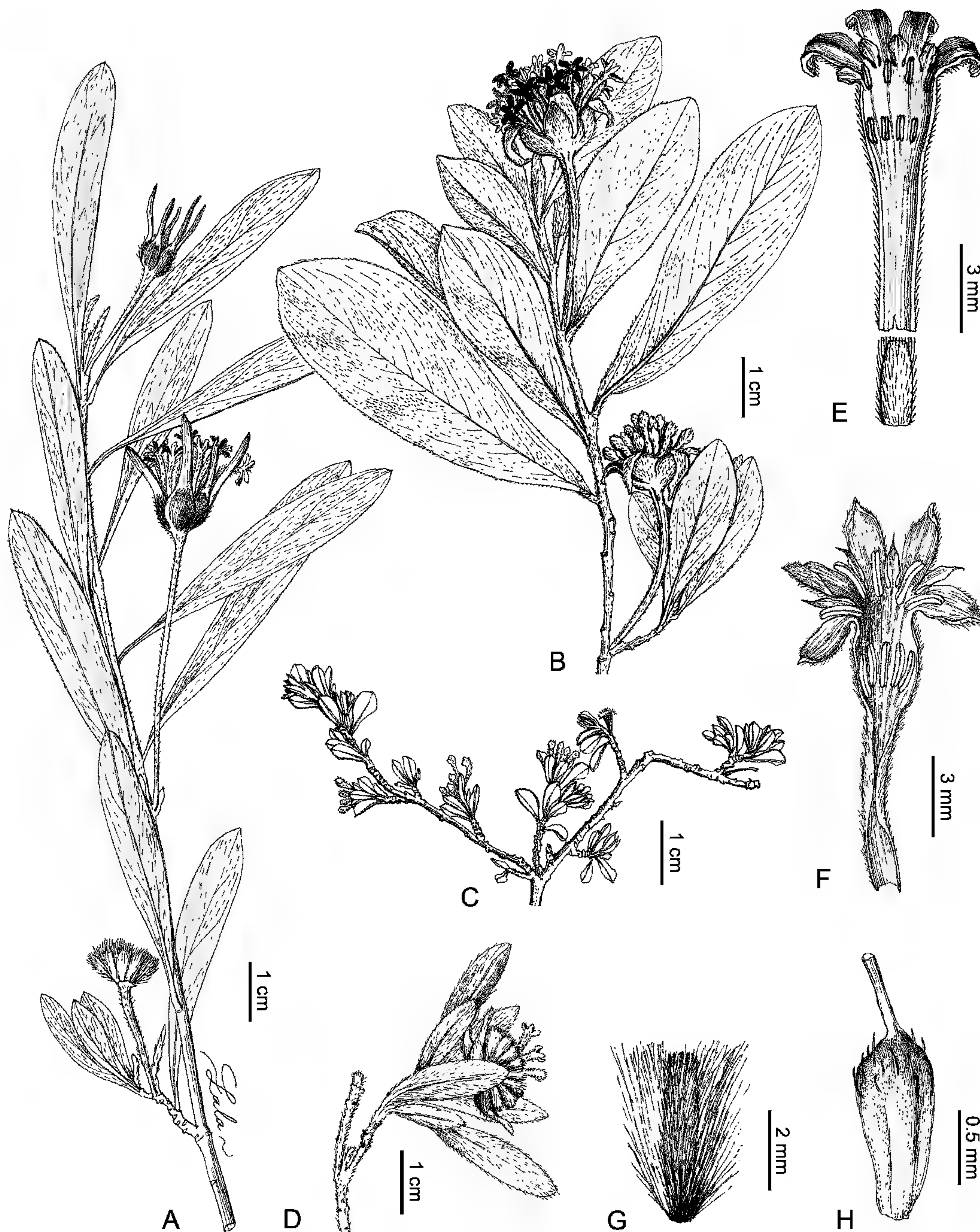

Figure 4. *Gnidia daphnifolia* L. f. —A–D. Habits. Note large amount of variation in leaves, length of peduncles, and the apex of bracts. —E, F. Flowers, with dissections of caducous portion of hypanthium. One sepal, one petaloid scale, and two anthers removed from part E. Note size and shape variation in the petaloid scales and anthers. —G. Persistent portion of hypanthium. —H. Gynoecium. Habits drawn from *Rogers & Rakotonasolo 133* (part A, MO), *Service Forestier (Rabevohitra) 34923* (part B, TEF), *Humbert 12844* (part C, type of *Lasiosiphon suffrutescens*, TAN), and *Humbert 18836* (part D, TAN). Floral parts drawn from *Service Forestier (Rabevohitra) 34923* (part E, TEF), *Rogers & Rakotonasolo 133* (part F, MO), *Humbert 18836* (part G, TAN), and *Humbert 12844* (part H, TAN).

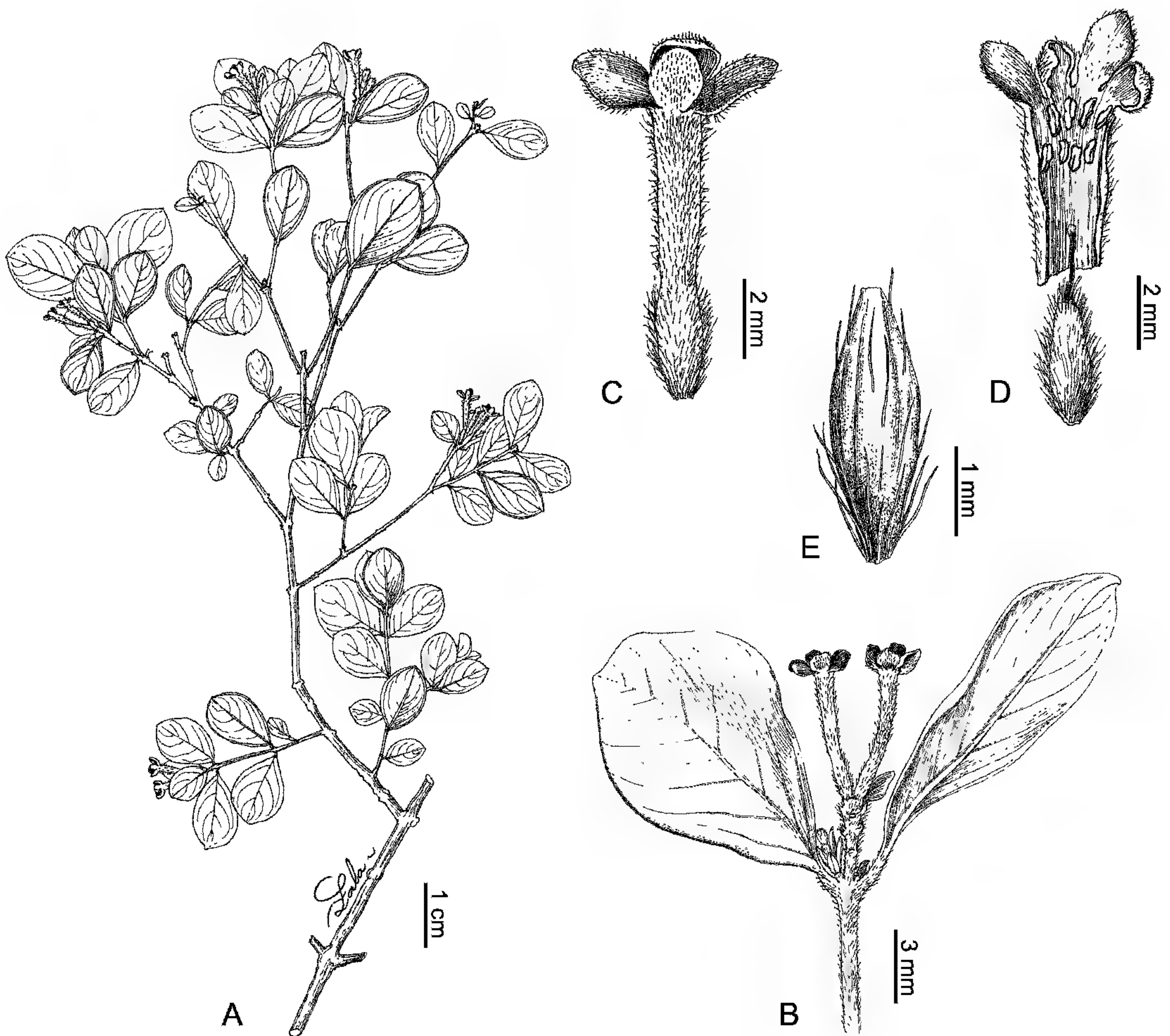

Figure 5. *Gnidia decaryana* Leandri. —A. Habit. —B. Inflorescence. Note small bracteole subtending flower. —C. Flower. —D. Dissection of caducous portion of hypanthium (above), and the persistent portion surrounding the gynoecium (below). —E. Fruit. Habit drawn from *Service Forestier (Capuron) 28650 (P)*. Inflorescence and flower drawn from *Rogers & Rakotonasolo 108 (MO)*. Fruit drawn from *Decary 4332 (TAN)*.

There is substantial variation in the inflorescence structure of Malagasy *Gnidia*. Nine of the 14 species have many-flowered, long-pedunculate, involucrate inflorescences (e.g., *G. linearis*, Fig. 10A, C). The remaining species possess one of the following kinds of inflorescences: (1) 1-flowered, ebracteate, terminal, and sessile (*G. razakamalalana*, Fig. 14A); (2) few-flowered, ebracteate, and long-pedunculate (*G. neglecta*, Fig. 11C); (3) few-flowered, bracteate, and sessile or subsessile (*G. decaryana*, Fig. 5B); (4) many-flowered, bracteate, and long-pedunculate with flowers racemously arranged along a short fertile portion at the tip of an otherwise sterile peduncle (*G. danguyana*, Fig. 3A); (5) many-flowered, bracteate, composite-like heads (*G. gnidioides*, Fig. 7A).

Peduncles are usually erect and sparsely pubescent with the same kind and density of indument as that

found on the leaves. Leandri (1931a, b, 1947, 1950) considered peduncle length to be an important taxonomic character to distinguish between species possessing involucrate inflorescences. His observations were based, in most cases, on one or two collections and the length distinctions he used to distinguish species collapse immediately when additional specimens are examined. In actuality, the majority of the species have highly variable peduncle length. For example, on a single specimen of *G. daphnifolia* the flowering peduncles can be 3–5 cm long, while others even in the fruiting stage might only reach 1.5 cm long. Nonetheless, species can generally be classified according to the length of their peduncles as follows: (1) completely absent (e.g., *G. ambondrombensis*), or nearly so (e.g., *G. gnidioides*); (2) short, no more than 8 mm long (e.g., *G. hibber-*

tioides, *G. perrieri*); (3) long, reaching 5 cm or more in length (e.g., *G. bojeriana*, *G. danguyana*, *G. daphnifolia*).

Involucrate inflorescences are always many flowered and usually consist of five, or rarely six, imbricate bracts, but the involucre of *Gnidia gilbertae* are composed of only four, or rarely five, bracts. Involucral bracts may or may not be strongly differentiated from the leaves; however, in many species the bracts are noticeably different from the leaves in shape and size and sometimes in texture and indument. In general, involucral bracts are substantially smaller than the leaves. The bracts of most species are 2 to 3.5 times longer than wide. Bracts of *G. linearis* are typically almost orbicular (ca. 1–1.5:1), whereas those of *G. occidentalis* are more lanceolate (ca. 3–7:1). The bracts within an involucre may differ noticeably, as in *G. daphnifolia* and *G. perrieri*, where usually one or two of the innermost bracts will be narrower, shorter, and not as strongly acuminate as the rest.

Involucral bracts are usually broadly rounded at the base and acuminate or rostrate at the apex. Bracts rarely have conspicuous nervation, and the midrib is faint on both surfaces or only perceptible abaxially. Generally, bracts are appressed to the flowers and fruits, at least in their lower half, and remain persistent until all of the fruits have fallen off. The bracts usually fall off earlier in *Gnidia linearis* and sometimes *G. daphnifolia*, exposing relatively long trichomes on the pedicel and lower portion of the hypanthium that resemble bristles on a brush (e.g., Fig. 4A).

Generally, involucral bracts are coriaceous and indument typically remains densest on the abaxial surface and also on the upper half of the adaxial surface. Even after drying, bracts of *Gnidia perrieri* remain semi-succulent and become glaucous, as do the leaves. Trichome densities on the leaves and bracts are almost always positively correlated, but the indument on the bracts in *G. bojeriana* is much denser compared to the leaves. *Gnidia decaryana* (Fig. 5B) is the only Malagasy species with bracteoles.

FLOWERS

The flowers in *Gnidia* are hermaphroditic, diplostemonous, tubular, and either 4- (e.g., *G. danguyana*, Fig. 3C) or 5-merous (*G. razakamalalana*, Fig. 14C). Based on herbarium labels and personal observations, flower color is most often yellow. The character is usually always consistent within a single population; however, the feature appears to be more variable between populations of *G. daphnifolia* and *G. linearis* (yellow, orange, or red), *G. decaryana* (red-green,

yellow, or greenish white), and *G. gnidioides* (pink, red, white, or yellow). Flowers within a single inflorescence of *G. bojeriana* change from yellow or orange to red in late anthesis. Similar color changes may be occurring in other species (e.g., *G. daphnifolia*) given the variation reported on specimen labels. Conspicuous yellow blisters usually develop on the flowers (and fruits) of *G. danguyana* after drying, similar to those found in other distantly related Thymelaeoideae (e.g., *Aquilaria* Lam., *Phaleria*).

Flowers are sessile to short pedicellate. The pedicels of species without involucrate inflorescences are glabrous to moderately pubescent with short trichomes, and similar to those borne on the leaves and peduncles. Pedicels of species with involucrate inflorescences are almost always 0–1.5 mm long and hidden by long, silver, pedicel trichomes. The flowers of *Gnidia bojeriana* are borne on conspicuous 1.5–3.1 mm long pedicels (Fig. 2A) that are not always obvious in early anthesis without dissection. The pedicel trichomes may be similar in length to those borne on the persistent portion of the hypanthium (e.g., *G. bojeriana*, *G. perrieri*), or much longer (e.g., *G. gnidioides*, *G. linearis*). In the latter case, the trichomes reach up to 4 mm long and resemble a dense, silver-colored brush (Fig. 7D).

The floral tube is treated here as a hypanthium following Gilg (1894) and Herber (2003). For a thorough review concerning the various interpretations of the structure, see Heinig (1951). In Malagasy *Gnidia*, the hypanthium is cylindrical or nearly so and the tube is almost always articulated slightly above the ovary. The portion of the hypanthium above the articulation line falls away, while the portion below the line persists and surrounds the developing fruit. In the remainder of this paper, the part of the tube above the line will be referred to as the caducous portion, while the part below the line will be described as the persistent portion. Only two species of the entire genus are known to completely lack the articulated hypanthium, the continental African *G. glauca* and the Malagasy *G. gilbertae* (Fig. 6B). In *G. gilbertae*, the lower one third of the tube tears irregularly across as the fruit develops. In species with both articulated and unarticulated flowers, the fruit remains inside the persistent portion through dispersal.

Leandri (1931a, b, 1947, 1950) considered the length of the hypanthium to be an important taxonomic character, and certainly there is some taxonomically distinctive variation in several species. *Gnidia razakamalalana*, with its 5 cm long hypanthium, has the longest flowers in the genus and perhaps even in the family (Rogers, 2006). Tubes of the remaining Malagasy species approach but never reach 2 cm in length. In a few species, such as *G.*



Figure 6. *Gnidia gilbertae* Drake. —A. Habit. —B. Flower. —C. Gynoecium. Drawn from *Hb. Inst. Sci. Madag.* 482 (TAN).

daphnifolia, the hypanthium may vary greatly (6.5–15 mm long) among populations and even between individuals within the same population. This observation cannot always be explained by differences in the developmental stage of the inflorescences or flowers. The persistent portion of the hypanthium is usually 2–4(–5) mm long, except in *G. hibbertioides*, where it is 5–7 mm long.

The density and length of trichomes on the hypanthium of Malagasy *Gnidia* are taxonomically

important characters. *Gnidia neglecta* is the only species with a completely glabrous hypanthium, inside and out (Fig. 11C). For species with internally pubescent tubes, the indument is generally most prevalent just above the articulation. The inner surface of the hypanthia in *G. ambondrombensis* and *G. danguyana* is the most obviously pubescent of any species in Madagascar, but the indument itself usually remains only faintly visible with magnification (these trichomes are sometimes impossible to see when

flowers are wet). In most species, however, the outer surface of the hypanthium, above and below the articulation, is covered with a conspicuous dense, appressed or subappressed indument (e.g., *G. humbertii*, Fig. 9B). The trichomes on the outer surface of the hypanthium are either of uniform length (e.g., *G. decaryana*, Fig. 5C) or noticeably (i.e., ca. 2–5 times) longer on the persistent portion (e.g., *G. linearis*, Fig. 10D, E). In these cases, the trichomes borne on the persistent portion of the hypanthium are generally longer in the lower half and become shorter approaching the articulation. The ratio of trichome length on the upper versus lower portion of the hypanthium varies substantially between populations of *G. daphnifolia*, where northern populations have flowers with trichome ratios of 3.5–5:1 (above:below the articulation) and southeastern populations fall into the 1.5–2.5:1 range.

A unique condition exists in *Gnidia gnidioides* where the hypanthium on the abaxial surface is densely pubescent above the articulation and completely glabrous below (Fig. 7B, note the long brush of trichomes belongs to the pedicel). The long trichomes on the persistent portion of *G. daphnifolia* aid in fruit dispersal, allowing the fruit enclosed in the lower part of the hypanthium to be carried farther by the wind (Rogers, pers. obs.). Beaumont et al. (2001a) speculated that long trichomes on the persistent portion of *G. polycephala* (E. Mey. ex Meisn.) Gilg, a mainland African species, aid in wind dispersal. Many other African species possess long trichomes on the persistent portion of the hypanthium and those probably serve a similar function.

The number of calyx lobes in Malagasy *Gnidia* is consistently either four or five, with twice the number of stamens, respectively. Five species have flowers with four lobes (and eight stamens): *G. danguyana*, *G. decaryana*, *G. gilbertae*, *G. gnidioides*, *G. neglecta*. Aestivation of the calyx lobes is always imbricate. During anthesis, lobes spread and normally become adaxially convex. For most species, the apex of the lobe is usually rounded (*G. decaryana*, Fig. 5C) or emarginate (*G. linearis*, Fig. 10D, E). Lobes are generally obovate or oblong, ca. 1.5–3 × 1.5–3 mm, and ca. 2 to 3 times larger than the petaloid scales (when those are present; discussed in next paragraph). Sometimes one lobe (when 5-merous) or two lobes (when 4-merous) are ca. 1/2 to 3/4 the size of the others. Generally, calyx lobes are glabrous adaxially and densely pubescent abaxially with an indument similar to, or slightly longer than, that present on the outer surface of the hypanthium.

More than half of the Malagasy species have small scale-like structures located in the sinuses of adjacent

calyx lobes (e.g., Fig. 14C, F). There has been much controversy regarding the interpretation of these organs, which are regarded here as petaloid scales (see review in Heinig, 1951). Petaloid scales are membranous, glabrous, free, and equal in number to the calyx lobes. Six species lack these petaloid scales: *Gnidia ambondrombensis*, *G. danguyana*, *G. decaryana*, *G. gnidioides*, *G. neglecta*, and usually *G. humbertii*. Scales generally fall into the 0.5–2 × 0.5–1 mm range. Some species have a large amount of size and shape variation within a species (e.g., *G. daphnifolia*, *G. linearis*). Most Malagasy species have scales that are usually apically rounded, emarginate, acute, or only rarely possess up to a few rounded lobes. Petaloid scales are generally the same color or slightly lighter than the calyx lobes. No scale vascularization was obvious with a dissecting scope for any species. When fresh, the scales of some populations of *G. linearis* are weakly carinate and this ridge becomes darker after drying.

The androecium of *Gnidia* consists of two equal whorls of four or five stamens per cycle with each whorl positioned at different heights within the tube. No rudimentary or aborted stamens were observed, as is known to occur in a few continental African species of *Gnidia* (e.g., *G. aberrans* C. H. Wright, *G. anomala* Meisn.). In a few Malagasy species, the anthers of the lower whorl were rarely observed as being about half the size of those in the upper whorl, but these smaller anthers still produced pollen. Stamens are glabrous and introrse. Filaments are narrow, membranous, and usually almost completely adnate to the inner wall of the hypanthium (sometimes only weakly fused), which results in sessile or subsessile anthers. The upper whorl of stamens is opposite the sepals and generally borne near the mouth or partially exerted. Rarely, the entire length of the anthers is exerted. The lower whorl alternates with the sepals and is borne ca. 0–2(–4) mm below the upper whorl. Anthers are basifixed, bithecal, and longitudinally dehiscent.

A small annular or cupuliform disk surrounds the base of the ovary in most Malagasy species and is referred to as the subgynoecial disk in the taxonomic treatment. The disk is glabrous, fleshy, and usually ca. 0.1–0.3 mm tall, but reaches 0.7 mm tall in *Gnidia ambondrombensis* (Fig. 1D). Disks are completely absent or inconspicuous (i.e., less than 0.1 mm tall) in the flowers of *G. danguyana* and *G. decaryana*. The apex of the disk is most often smooth or shallowly lobed. Lobing is often irregular, and individual lobes rarely attain one third of the total height of the disk.

The gynoecium is composed of a pseudomonamous ovary (only one of the two uniovulate carpels

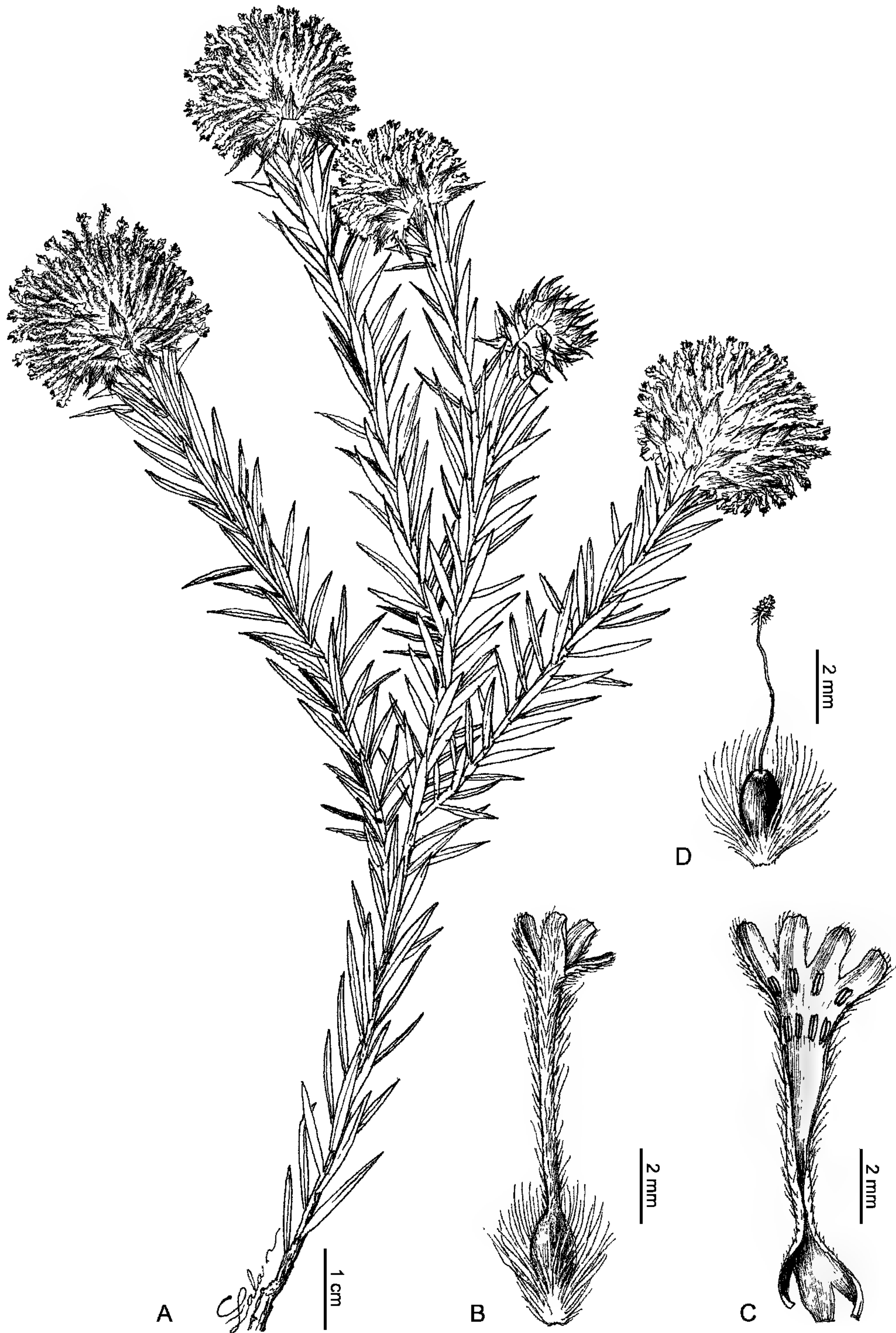

Figure 7. *Gnidia gnidioides* (Baker) Domke. —A. Habit. —B, C. Flower. Note long brush of pedicel trichomes in B. —D. Gynoecium. Drawn from *Rogers et al.* 126 (MO).

develops), a lateral style, and a capitate stigma. Ovules are anatropous and suspended. The superior ovary is completely free from the hypanthium and shortly stipitate at the base in most species. Most variation of the ovary is related to the density, position, and length of trichomes on the surface. Typically, the entire ovary is either sparsely pubescent or glabrescent. When pubescent, the indument on most of the surface is caducous with only a few trichomes remaining at the apex in mature fruit. In a few species, the apex of the ovary is covered by a conspicuous brush of relatively long, silver trichomes (e.g., *Gnidia danguyana*, Fig. 3C) that persists through fruit.

The style is filiform, straight, and persistent in fruit. Styles are glabrous, but rarely a few trichomes are irregularly found along its length. Style length may vary significantly between populations and sometimes individuals, but this variation is not associated with differences in the position of anthers within the tube, and thus the flowers are probably not truly heterostylous.

Stigmas are always papillate and usually globose (Fig. 2C). At anthesis, in a single population or species, the stigma can be at the height of either whorl of anthers, several millimeters below the lowest whorl, or slightly above the articulation. Stigmas never surpass the upper whorl in any Malagasy species.

FRUITS

Fruits are small single-seeded achenes that remain completely surrounded by the lower portion of the hypanthium when mature (Fig. 5D, E). Most species have ellipsoid fruits from 2–4 mm long. Two species have distinctly ovoid fruits, *Gnidia bojeriana* and *G. danguyana*. In fruit, the persistent styles in species with articulated hypanthia will protrude through the apical circular aperture of the persistent portion (Fig. 1C). The pericarp is dry, thin, and usually membranous, except in *G. bojeriana* where it is commonly more fleshy and opaque. Most of the indument on the ovary is lost as the fruit develops, but the fruits of two species, *G. danguyana* and *G. decaryana*, retain the distinctive brush of apical trichomes from the ovary.

SEEDS

Seeds show minor variation with the shape and size essentially matching that of the fruit. The seed coat is crustaceous, thin, and can be either black or dark brown. The embryo is fleshy and the endosperm is absent from mature seeds. Cotyledons are slightly flattened in cross-section, and the radicle and plumule are minute.

DISTRIBUTION AND ECOLOGY

All 14 species are Malagasy endemics and their distributions are provided in Figures 15–17. Given the wide distribution of some species of *Gnidia* in Madagascar, it is rather surprising that the genus has not been found in the nearby Comoro Archipelago. The genus occurs in all five provinces (Antananarivo, Fianarantsoa, Mahajanga, Toamasina, Toliara) and in each of five simplified bioclimatic zones (humid, subhumid, montane, dry, subarid) as discussed in Schatz (2000). The general bioclimate transitions from wet to dry from east to west across the island, but the far north is particularly arid.

Clearly, some species are restricted to higher elevations (ca. 1000–2550 m) along the central plateau in the subhumid and montane bioclimatic zones, e.g., *Gnidia ambondrombensis*, *G. gnidioides*, *G. perrieri*. *Gnidia bojeriana* is basically limited to mid-elevations in the subhumid zone. *Gnidia danguyana* and *G. neglecta* are endemic to fragments of coastal littoral forest near sea level in the island's humid bioclimate. *Gnidia gilbertae* and *G. occidentalis* occur on the drier western side of the central plateau in northwestern Madagascar (dry bioclimatic zone). *Gnidia humbertii* is restricted to the subarid zone. *Gnidia linearis* is almost completely confined to the subarid zone in southern and southwestern Madagascar. Five species appear to be narrow endemics: *G. ambondrombensis* (Mt. Ambondrombe), *G. hibbertioides* (exact locality unknown), *G. neglecta* (Andevoranto), *G. perrieri* (Andringitra), *G. razakamalalana* (Ivohibe Forest). Two species, *G. neglecta* and *G. hibbertioides*, are only known from their type collection.

Ecologically, Malagasy *Gnidia* are associated with open sunlit areas and found in habitats periodically disturbed by fire. *Gnidia gnidioides* grows in marshes and other moist places. Numerous recently revised Malagasy genera in other families, e.g., *Buxus* L. (Schatz & Lowry, 2002), *Ehretia* P. Browne (Miller, 2002), and *Leptolaena* Thouars (Schatz et al., 2001), are reportedly associated with, and restricted to, particular soil and rock types. This does not appear to be the case for most species of *Gnidia* on the island. *Gnidia daphnifolia* has been recorded on a number of diverse substrates including sand, laterite, limestone, granite and gneiss, and perhaps marble, whereas *G. linearis*, mostly confined to the southern and southwestern part of the island, occurs on sand, sandstone, and calcareous limestone. Based on label data and personal observations, four species apparently show substrate-specific distributions: *G. danguyana* and *G. neglecta* only occur on sand; *G. ambondrombensis* and *G. razakamalalana* grow on black soil on granite rock.

In regards to phenology, many Malagasy species, especially widespread ones, may flower and fruit year round, at least within some part of their geographic range.

VERNACULAR NAMES AND USES

According to dozens of herbarium specimen labels and several literature sources (e.g., Randriatavy, 1998), the most common vernacular name for *Gnidia* in Madagascar is havoah (also written as "avoha" and "havoha"), a Malagasy word for fiber. Fibrous bark of some *Gnidia* species (e.g., *G. linearis*, and probably *G. danguyana* and *G. daphnifolia*) is harvested as the raw material used in the fabrication of papier Antaimora, a coarse paper that was originally gathered and used locally (Estragon, 1933), but now is used as part of a much larger handicraft trade and sold to tourists (M. Madeleine & R. Ramiandrisoa, pers. comm.; Rogers, pers. obs.). Randriatavy (1998) reported that the bark of *Dais glaucescens* Decne. in C. A. Mey., which superficially resembles some other species of *Gnidia*, is also known as havoah and used to make papier Antaimora. Several other species of Thymelaeaceae are known by havoah or one of its orthographic variants in Madagascar, such as *Octolepis dioica* Capuron (Rogers, 2005), three species of *Stephanodaphne* (Rogers, 2004), and *Peddiea involu-crata* Baker.

In addition to paper, local artisans have reported that the bark of *Gnidia* is used to make ceremonial clothing (M. Madeleine & R. Ramiandrisoa, pers. comm.), and bark of *G. daphnifolia* is used for cordage (Luckow 4226). The leaves of *G. gilbertae* are ingested to induce vomiting (Randrianaivo et al. 614).

CONSERVATION STATUS

At least some Malagasy species of *Gnidia* survive annual burning regimes and grazing by livestock through resprouting from underground rootstocks (Rogers, pers. obs.). A few species commonly harvested for the papier Antaimora trade are reported to regenerate from a xylopodium after the above ground growth is cut (M. Madeleine & R. Ramiandrisoa, pers. comm.). Vigorous populations of *G. bojeriana*, *G. daphnifolia*, *G. gnidioides*, and *G. linearis* were observed in highly disturbed unprotected areas, including cow pastures, cultivated fields, *Pinus* L. stands, and along the edges of towns. Altogether, these factors suggest that most Malagasy *Gnidia* are not particularly threatened, and thus seven of the 14 species are considered species of Least Concern (LC)

by IUCN (2001) criteria. *Gnidia neglecta* and *G. hibbertioides* are the only two species assigned a preliminary status of Critically Endangered (CE), while *G. razakamalalana* and *G. ambondrombensis* are Endangered (EN). *Gnidia danguyana* and *G. perrieri* are considered Vulnerable (VU) to extinction.

TAXONOMIC TREATMENT

Gnidia L., Sp. Pl. 1: 358. 1753. TYPE: *Gnidia pinifolia* L.

Dessenia Adans., Fam. Pl. 2: 285. 1763, nom. superfl.

Lasiosiphon Fresen., Flora 21: 602. 1838. TYPE: *Lasiosiphon glaucus* Fresen. [= *Gnidia glauca* (Fresen.) Gilg].

Arthrosolen C. A. Mey., Bull. Cl. Phys.-Math. Acad. Imp. Sci. Saint-Pétersbourg, sér. 2, 1: 356, 359. 1843. TYPE: *Arthrosolen spicatus* (L. f.) C. A. Mey. [= *Passerina spicata* L. f.].

Shrubs or small trees. **Leaves** alternate to opposite, sometimes decussate; venation generally brochidodromous, often inconspicuous in needle-shaped leaves. **Inflorescences** terminal or axillary, usually composed of many-flowered heads borne on elongating peduncles; bracts usually involucrel, less often foliose, poorly differentiated, or absent. **Flowers** hermaphroditic, tubular, 4- or 5-merous, actinomorphic; hypanthium \pm cylindrical (in Madagascar) to funnel-shaped, articulated above the ovary (unarticulated in *Gnidia glauca* in Africa, *G. gilbertae* in Madagascar, and also possibly *G. razakamalalana*); upper portion of hypanthium caducous in late anthesis; lower portion of hypanthium persistent; calyx lobes 4 or 5, imbricate, spreading; petaloid scales usually small or absent, alternisepalous (adnate to the sinus between adjacent calyx lobes), free, thin, membranous; androecium diplostemonous; stamens 8 or 10, arranged in 2 alternating whorls at different heights, introrse, included or rarely only the upper whorl slightly exerted; filaments fused to the inner wall of the hypanthium for most of their length; anthers basifixed, bithecal, longitudinally dehiscent, sessile or subsessile; subgynoecial disk small or absent, annular or cupuliform when present; gynoecium pseudomonomerous; ovary sessile to shortly stipitate at base; ovule 1, apical, anatropous; style lateral, filiform, persistent; stigma usually capitate and globose, rarely fusiform or club-shaped, papillate, included or nearly so. **Fruits** small, single-seeded achenes, enclosed by the persistent lower portion of the hypanthium; pericarp thin, dry, membranous, rarely coriaceous or semi-fleshy. **Seeds** with a thin, crustaceous coat; endosperm absent.

KEY TO THE MALAGASY SPECIES OF *GNIDIA*

- 1a. Calyx lobes 4; stamens 8.
- 2a. Phyllotaxy opposite to decussate, sometimes subopposite or less often alternate on vigorous shoots; inflorescence bracts 0 to 4, not imbricate.
- 3a. Leaf blades 1–8.3 × 0.6–5 cm; petioles 1–4 mm long; inflorescences 6- to 23-flowered, flowers racemously arranged along a short, fertile portion of a much longer, mostly sterile peduncle 3. *G. danguyana*
- 3b. Leaf blades 0.4–1.8 × 0.2–1.2 cm; petioles to 1 mm long; inflorescences 2- to 4-flowered, flowers arranged in a sessile, subsessile, or long-pedunculate cluster.
- 4a. Leaves broadly ovate, leaf base cordate; fine venation clearly visible and uniformly reticulate, densely congested and darker than the blade; inflorescences with peduncles to 2.5 cm long; hypanthium glabrous externally 11. *G. neglecta*
- 4b. Leaves obovate to suborbicular, leaf base cuneate to attenuate; fine venation usually inconspicuous, when visible weakly anastomosing and concolorous with the blade; inflorescences sessile or subsessile; hypanthium densely pubescent externally 5. *G. decaryana*
- 2b. Phyllotaxy alternate, rarely subopposite; inflorescence bracts 4 to many, imbricate.
- 5a. Leaf blades needle-shaped, rarely very narrowly obovate or ovate; inflorescences 50- to 100-flowered; flowers arranged in composite-like heads 7. *G. gnidioides*
- 5b. Leaf blades broadly obovate to nearly elliptic; inflorescences to 28-flowered; flowers arranged in a capitulum and surrounded by 4 or 5 involucre bracts 6. *G. gilbertae*
- 1b. Calyx lobes 5; stamens 10.
- 6a. Inflorescences 1-flowered; hypanthium ca. 5 cm long 14. *G. razakamalalana*
- 6b. Inflorescences 6- to 40-flowered; hypanthium to 1.9 cm long.
- 7a. Calyx lobes 7–8.3 × 3.5–4.2 mm 1. *G. ambondrombensis*
- 7b. Calyx lobes rarely to 5.2 × 2.5 mm.
- 8a. Petaloid scales 4.6–6 × 3.8–4.7 mm, upper half irregularly lacerate or sinuate; persistent portion of hypanthium 5–7 mm long 8. *G. hibbertioides*
- 8b. Petaloid scales rarely to 3.7 × 2 mm, upper half acute to rounded, emarginate, or rarely with a few rounded lobes; persistent portion of hypanthium rarely to 5 mm long.
- 9a. Rounded, compact, densely ramified subshrubs; both leaf surfaces hidden by a dense sericeous indument 9. *G. humbertii*
- 9b. Laxly branched shrubs to small trees; both leaf surfaces usually visible, or only the abaxial leaf surface rarely obscured by dense strigose or tomentose indument.
- 10a. Inflorescences drooping on living plants; involucre bracts strongly recurved (most obvious on fresh material), the largest (6–)8–16 mm wide; pedicels 1.5–3.1 mm long; persistent portion of hypanthium at least twice the diameter of the caducous portion . . . 2. *G. bojeriana*
- 10b. Inflorescences erect on living plants; involucre bracts erect or spreading, and planar or reflexed near the midpoint (but never recurved), the largest rarely to 8 mm wide; pedicels 0–1.5 mm long; persistent and caducous portion of the hypanthium roughly the same diameter.
- 11a. Broadest leaf blades 7–21 mm wide; bracts usually long-acuminate or rostrate, often with a reflexed upper half, less often short-acuminate or acute and + erect.
- 12a. Involucre bracts generally broadly ovate (l:w ratios 2–4:1), usually drying black or brown in the lower half; hypanthium 6.5–12(–15) mm long; widespread throughout Madagascar 4. *G. daphnifolia*
- 12b. Involucre bracts narrowly lanceolate or elliptic-ovate (l:w ratios 3–7:1), drying light green, green-red, or yellow-brown throughout; hypanthium 12.5–16 mm long; restricted to northwestern Madagascar 12. *G. occidentalis*
- 11b. Broadest leaf blades 2–5(–9) mm wide; bracts with a 1–2 mm long, strongly decurved apicule (usually *G. linearis*), short-acuminate and spreading, or less often acute and + erect.
- 13a. Plants with completely glabrous stems and leaves; young stems red-purple or orange-red when dry; longest peduncles 2–5(–8) mm long; involucre bracts with l:w ratios of 2–3.5:1; subhumid region, endemic to Andringitra, 2000–2550 m elevation 13. *G. perrieri*
- 13b. Plants usually at least sparsely pubescent initially; young stems green, brown, or black when dry; longest peduncles (5–)10–50 mm long; involucre bracts with l:w ratios of 1–1.5(–2):1; dry and subarid regions in southern and western Madagascar, 0–1400 m elevation 10. *G. linearis*

1. *Gnidia ambondrombensis* (Boiteau) Z. S. Rogers, comb. nov. Basionym: *Lasiosiphon ambondrombensis* Boiteau, Bull. Trimestriel Acad. Malgache, n.s., 24: 83. 1941 [1942], as “*ambondrombense*.”
TYPE: Madagascar. Fianarantsoa: Mt. Ambon-

drombe, rocky summit, 1900 m, 11 Apr. 1941, P. Boiteau (Hb. Jard. Bot. Tananarive) 4643 (holotype, P!; isotypes, MO!, TAN!). Figure 1.
Sparsely branched subshrubs to 60 cm tall; internodes inconspicuous; young branches densely seri-

ceous to tomentose, covered with prominent leaf scars; bark of mature branches often exfoliating. **Leaves** alternate, spirally arranged, sessile, very closely spaced (adjacent leaf bases overlapping), persistent only at tips of branches; blades broadly obovate or elliptic, $1.5\text{--}2.3 \times 0.5\text{--}1.1$ cm, l:w ratios ca. 2–3:1, silver-green, both surfaces completely obscured with a dense sericeous indument (trichomes 1–1.5 mm), apex apiculate or obtuse, base long-attenuate; midrib and venation obscured by indument. **Inflorescences** terminal, erect, capitate, 8- to 15-flowered, sessile, surrounded by a rosette of leaves; involucre bracts 5, similar to leaves (ca. $3/4$ the size and less obovate compared to adjacent leaves), $8.3\text{--}9 \times 3.3\text{--}3.8$ mm, l:w ratios 2.3–2.7:1, densely pubescent in upper half adaxially, sparsely pubescent to glabrescent in lower half abaxially; midrib strongly raised adaxially, inconspicuous abaxially; nervation inconspicuous on both surfaces, or very faint in lower half adaxially. **Flowers** 5-merous, yellow; pedicels 0.7–1 mm, covered by 0.3–0.8 mm trichomes; hypanthium 14–16 mm, articulate (line sometimes faint), coriaceous; caducous portion covered by dense indument externally, trichomes ca. 1 mm, sparsely to moderately pubescent internally; persistent portion 3–4 mm, covered with dense indument externally, trichomes 1–2 mm, moderately pubescent internally; calyx lobes 5, spreading or reflexed, broadly elliptic to obovate, $7\text{--}8.3 \times 3.5\text{--}4.2$ mm, more membranous than hypanthium, glabrous adaxially, densely to moderately pubescent abaxially, apex emarginate; petaloid scales absent; stamens 10, upper whorl of anthers ca. half-exserted, lower whorl 1.5–2 mm below upper whorl; anthers oblong, $1.2\text{--}1.5 \times 0.4\text{--}0.6$ mm, subsessile; subgynoecial disk cupuliform, 0.4–0.6 mm tall, glabrous, fleshy, apex irregularly lobed, sinuses shallow to deep; ovary ellipsoid, ca. 1.6×1 mm, stipitate (stipe 0.3–0.4 mm), lower half glabrescent or sparsely pubescent, upper half moderately pubescent, apex densely pubescent, trichomes 1–1.5 mm; style 3–7.1 mm, glabrous; stigma inserted, ca. 2 mm below lower whorl of anthers. **Fruits** not seen.

Distribution and habitat. *Gnidia ambondrombensis* is endemic to the windswept summit of Mount Ambondrombe from 1800–1900 m elevation (Fig. 15). The site is situated along the boundary separating the subhumid and humid bioclimatic zones. The only known population grows on scattered patches of soil on a large outcrop of weathered granite that caps the peak.

Phenology. The species has been collected in flower in April, May, and October.

Vernacular name. Borona (Boiteau [Hb. Jard. Bot. Tananarive] 4643).

IUCN Red List category. More than 100 individuals of *Gnidia ambondrombensis* were observed on the summit of Ambondrombe Mountain in 2004 (Rogers, pers. obs.). While the site is not formally protected, the remaining forest on the mountain, located between 1400 and 1900 m elevation, are considered sacred by the local people. As a result, woodcutting and burning inside the forest are regarded as taboo and are not permitted by leaders living in the villages below the forest. In fact, this local ban probably grants the Ambondrombe forest more protection than most government-protected lands. Nevertheless, agricultural fields border the edge of the forest and some trees are still selectively cut down for local use. This species is assigned a conservation status of Endangered (EN) according to IUCN (2001) criteria because the species is known from a single unprotected population with an estimated area of occurrence (AOO) of 1 km² (B1ab + 2ab; D1). Our attempt to bring this attractive species into cultivation in 2004 proved unsuccessful, but additional efforts should be made to ensure the longevity of the species.

Discussion. *Gnidia ambondrombensis* is recognized by its sparsely branched habit, closely spaced leaves that are covered on both surfaces by a dense sericeous indument (trichomes 1–1.5 mm long), its sessile inflorescences, and by its large ($7\text{--}8.3 \times 3.5\text{--}4.2$ mm) calyx lobes. *Gnidia humbertii*, another species with very dense vegetative indument and closely arranged leaves, differs by its distinctive rounded, compact, densely ramified habit, narrower leaves (1.9–3 vs. 5–11 mm wide) with shorter sericeous indument (trichomes 0.2–0.5 mm long), and its much smaller ($2\text{--}4.5 \times 1.7\text{--}2.5$ mm) calyx lobes.

Selected specimen examined. MADAGASCAR. **Fianarantsoa:** Mt. Ambondrombe, summit, Rogers & Rakotonasolo 706 (K, MO [2], P, TAN).

2. *Gnidia bojeriana* (Decne.) Gilg, Nat. Pflanzenfam. 3(6a): 228. 1894. Basionym: *Lasiosiphon bojerianus* Decne., Voy. Inde 4: 149. 1844. TYPE: Madagascar. Antananarivo: Emirae, mtns., s.d., W. Bojer s.n. (lectotype, designated here, P 00370315!; isotypes, BM!, K!, P [2!]). Figure 2.

Gnidia bojeriana Baill., Hist. Phys. Madagascar, 35(5) [Atlas 3], pl. 312. 1895, nom. illeg. TYPE: "Madagascar" (type, pl. 312!, Baillon in Grandidier, 1895).

Shrubs to 1.5 m tall; bark dark gray-brown, usually lenticellate, densely pubescent on young branches. **Leaves** alternate, persistent on older branchlets, subsessile or petiolate; petioles to 4 mm, densely

pubescent; blades narrowly elliptic or obovate, 1.6–7(–8.4) × 0.3–1.1(–1.5) cm, l:w ratios ca. 4–7:1, both surfaces densely to moderately strigose (trichomes ca. 1–1.5 mm), apex apiculate, base long-attenuate; midrib plane or slightly depressed adaxially, raised and lighter than blade abaxially; venation raised on both surfaces, more pronounced abaxially. **Inflorescences** axillary, pedunculate, drooping when living, involucre, (22- to)30- to 40-flowered; peduncles (0.4–)1–5 cm, densely pubescent; involucre bracts 5, broadly ovate, (9–)13–25 × (6–)8–16 mm, l:w ratios 2–3:1, persistent, green-yellow, becoming strongly recurved (often only obvious on fresh material), both surfaces obscured by dense pubescence, apex apiculate or acute, base rounded to truncate; midrib plane or inconspicuous adaxially, raised abaxially; nervation usually conspicuous. **Flowers** 5-merous, yellow, becoming orange-red in late anthesis, pedicellate; pedicels 1.5–3.1 mm, light green, densely puberulent, trichomes 0.2–0.4 mm, slightly longer near flower; hypanthium 9–11 mm, articulate, coriaceous, densely pubescent externally, trichomes ca. 0.2–0.5 mm, sometimes slightly longer and denser below articulation, glabrescent to moderately puberulent between anthers and ovary internally; caducous portion ca. 0.5 mm wide, becoming light brown after anthesis; persistent portion 3–4 mm, ca. 2 mm diam. (i.e., at least twice the diam. of the caducous portion); calyx lobes 5, spreading, broadly elliptic or obovate, 1.9–2.8 × 1–2.1 mm, glabrous adaxially, densely pubescent abaxially, apex emarginate or rarely rounded; petaloid scales 5, ovate-oblong, 0.5–0.9 × 0.2–0.3 mm, membranous, glabrous, lighter yellow than the calyx lobes when fresh, apex emarginate or rounded; stamens 10, upper whorl of anthers ca. 1/2 to 3/4 exerted, lower whorl 0.2–0.5 mm below upper whorl; anthers oblong, 0.8–1.2 × 0.2–0.4 mm, sessile or subsessile; subgynoecial disk cupuliform, to 0.4 mm tall, glabrous, fleshy, apex smooth or irregularly lobed; ovary ovoid to ellipsoid, 1.5–1.7 × 0.6–0.7 mm, stipitate (stipe to 0.3 mm), moderately to sparsely pubescent, denser in upper half, trichomes 0.4–0.7 mm; style 2.7–5.6 mm, glabrous; stigma near mouth or at height of lower whorl of anthers. **Fruits** ovoid, 3.2–3.5 × 1.5–1.7 mm, sparsely to moderately pubescent, denser in upper half; pericarp membranous or fleshy.

Distribution and habitat. *Gnidia bojeriana* occurs along the central plateau of Madagascar from Antananarivo to the Mahafaly Plateau and Isalo from 800–1700 m elevations (Fig. 15). The species is commonly found in open sunlit areas and notably present in Madagascar's tapia forests, woodlands dominated by species of *Uapaca bojeri* Baill. (Eu-

phorbiaceae). *Gnidia bojeriana* grows on gneiss, quartzite, and sandstone rock types in the subhumid and subarid bioclimatic zones.

Phenology. The species flowers and fruits from January through June.

Vernacular name. Kelimafana (Boiteau [Hb. Jard. Bot. Tananarive] 5051).

IUCN Red List category. *Gnidia bojeriana* is widespread and has been recorded in one protected area (Isalo). Populations dating back to 1928 at Isalo and 1959 near Arivonimamo were found again in 2006 and 2003, respectively, and more than 75 healthy individuals were seen in the latter population (Rogers, pers. obs.). The habitat in both areas is burned periodically, and the species obviously tolerates frequent disturbances over time. *Gnidia bojeriana* should be considered a species of Least Concern (LC) by IUCN (2001) criteria.

Discussion. *Gnidia bojeriana* is easy to recognize by its broad, strongly recurved involucre bracts measuring (6–)8–16 mm wide, its distinctly pedicellate flowers (pedicels 1.5–3.1 mm long), and its hypanthium with a persistent portion at least two times the diameter of the caducous portion. It is also worth noting that the recurved appearance of the bracts is usually lost on dried material, and that the peduncles on live plants droop distinctively.

Nomenclature and typification. The provenance in the protologue (Decaisne, 1844: 149) was cited as "Hab. Madagascar in montibus provinciae Emirnae (herb. Mus. Paris.*)" without mention of a specific collector or collection number. However, judging from the epithet it seems likely that the name was based on material that was either collected or provided by Wenceslas Bojer (1795–1856). Three unnumbered sheets attributed to Bojer were found at P bearing labels with the typewritten script Herb. Mus. Paris. Decaisne's handwriting does not appear to be present on any of the specimens, but one sheet (P 00370315) has the exact locality information cited in the protologue (except for the final "e" missing from the old provincial name Emirnae). Specimens on all sheets match the original description, and sheet P 00370315 is designated as the lectotype. Two other Bojer sheets of *Gnidia bojeriana* at BM and K are regarded as isoelectotypes.

Original material of the later validly published homonym *Gnidia bojeriana* Baill. (1895), non *G. bojeriana* (Decne.) Gilg (1894), is represented in the protologue by a nice diagnostic illustration bearing the inscriptions "Madagascar" and the name of the species, the latter of which did not include any authorship or other attribution to an earlier basionym

name published by Decaisne or Gilg. The plate without doubt corresponds taxonomically to *G. bojeriana* (Decne.) Gilg and must be regarded as the type of Baillon's name.

Selected specimens examined. MADAGASCAR. **Antananarivo:** Imerintsiatosika, Km 22 along Natl. Rte. #1 (Antananarivo–Imerintsiatosika), *Rogers & Randrianaivo 175* (BR, G, K, MO, P, TAN); Mahevelona, rte. Majunga, Km 47, *Rauh 1677* (TAN); Mt. Antongona, W of Antananarivo, *Perrier de la Bâthie 18459* (G, P [2], TAN). **Fianarantsoa:** Isalo Natl. Park, Tsimanabaro Tapia forest, *Rogers et al. 821* (K, MO, P, TAN, US); Itremo, *Perrier de la Bâthie 12472* (P).

3. *Gnidia danguyana* Leandri, Bull. Soc. Bot. France 77: 35. 1930. TYPE: Madagascar. Toamasina: Tampina forest, Dec. 1923, *M. Louvel 118* (lectotype, designated here, P!). Figure 3.

Shrubs or small trees to 6 m tall; young branches light green, densely to moderately pubescent; mature branches light brown-red to dark black-brown; bark often lenticellate. **Leaves** opposite to decussate, pairs sometimes suboppositely or alternately arranged on vigorous shoots, distinctly petiolate; petioles 1–4 mm, glabrous; blades broadly ovate or ovate-elliptic, 1–8.3 × 0.6–4.5(–5) cm, l:w ratios ca. 1.5–2.5:1, lighter in color abaxially, glabrous on both surfaces, apex acuminate, apiculate, or acute, rarely emarginate, margin with a distinct vein, base cordate or slightly cordate; midrib depressed adaxially, raised abaxially, glabrous, lighter green than blade on both surfaces; venation raised on both surfaces, more pronounced abaxially. **Inflorescences** terminal, drooping, 6- to 23-flowered, those racemosely arranged at the tip of a long and otherwise sterile peduncle; peduncles to 7 cm; sterile portion to 6.5 cm, glabrous; fertile portion to 1.3 cm, sparsely to moderately strigose or tomentose; inflorescence bracts 2 or 4, foliaceous, much smaller than leaves, 4–15 × 1–6 mm, l:w ratios 3–6:1, ± membranous, glabrous on both surfaces, apex acute or acuminate, base attenuate or cordate, often persistent in fruit; bract stalk 0.5–1 mm; midrib and nervation usually visible. **Flowers** 4-merous, yellow, often covered with yellowish blisters when dry, distinctly pedicellate; pedicels 3–4 mm, moderately to sparsely pubescent; hypanthium 7.5–9 mm, articulate, ± membranous, sparsely to moderately strigose externally (surface still clearly visible), trichomes 0.2–0.5 mm, glabrous internally; persistent portion 3–3.2 mm; calyx lobes 4, spreading, broadly elliptic or orbicular, 2–3.9 × 1.4–3 mm, glabrous adaxially, moderately to densely pubescent abaxially, smaller pair of lobes less pubescent, apex rounded; petaloid scales absent; stamens 8, upper whorl of anthers slightly below mouth or up to 1/4 exerted, lower whorl ca. 0.5–1 mm below

upper whorl; anthers elliptic, 0.6–0.8 × 0.2–0.3 mm; subgynoecial disk absent or cupuliform, composed of several irregularly fused segments when present, each segment to 0.2 mm tall, glabrous, apex irregularly lobed, sinuses shallow to deep; ovary ovoid to ellipsoid, 0.7–1 × 0.4–0.6 mm, stipitate (stipe ca. 0.1 mm), glabrous or sparsely strigose on lower half, becoming densely strigose at apex, trichomes 1–1.5 mm; style 2.5–3.6 mm, glabrous; stigma at height of lower whorl of anthers or just above articulation. **Fruits** ovoid, 2.9–3.2 × 1.8–2 mm, lower half glabrous, upper half glabrescent to sparsely strigose, apex densely pubescent; pericarp membranous.

Distribution and habitat. *Gnidia danguyana* is distributed along most of Madagascar's east coast littoral forest from the Masoala peninsula to around Fort Dauphin from 0–15 m elevation (Fig. 16). The species grows on sandy substrates in open, often disturbed, sunlit areas in the humid bioclimatic zone.

Phenology. The species flowers and fruits year round.

Vernacular names. Avoha (*Réserves Naturelles [Pierre] 8874, Plantes de Madagascar 5871*); havoa (*Service Forestier [Rakotomanana] 5100*); havoa hafotra (*Louvel 118, 197*).

IUCN Red List category. *Gnidia danguyana* has not yet been recorded within Madagascar's protected area network. The extent of occurrence (EOO) of the species is 18,200 km² and the AOO is 1600 km² given a 10 × 10 km grid cell size. Nine subpopulations occur in small patches of highly fragmented and severely threatened littoral forest (Consiglio et al., 2006). The species is assigned a preliminary IUCN (2001) conservation assessment of Vulnerable (VU) to extinction (1ab + 2ab).

Discussion. *Gnidia danguyana* is easily recognized by its large (1–8.3 × 0.6–5 cm), ovate or ovate-elliptic leaf blades with cordate or slightly cordate bases and by its distinctive 6- to 23-flowered inflorescences. *Gnidia neglecta* can be separated by its 2- to 4-flowered inflorescences and smaller leaves (8–17 × 4–12 mm) with conspicuous densely congested fine venation.

Typification. The original material for *Gnidia danguyana* was cited incorrectly in the protologue as "*M. Humbert 118, 197*" (Leandri, 1930a: 35). Both syntypes were actually collected by Louvel, rather than Humbert, a mistake that Leandri corrected years later in the *Flore de Madagascar et des Comores* (Leandri, 1950). One sheet of each syntype is deposited at P. Both are annotated by Leandri, closely match the description, and bear the same handwritten

locality on the label. *Louvel 118* (P) is chosen as the lectotype because it is fertile and in better physical condition than *Louvel 197* (P).

Selected specimens examined. MADAGASCAR. **Antsir-anana:** Masoala Natl. Park, near Cap Est, *Schmidt et al. 4402* (BR, G, K, MO, P, TAN, US, WAG). **Fianarantsoa:** Ampasimanava, Ambahy, N of Nosy Varika, Ambolo Forest, *Razakamalala et al. 1445* (MO, P, TEF); Mahabo forest, ca. 4 km NE of Mahabo village, *Rogers et al. 76* (B, BOL, K, L, LE, MO [2], NY, P, PE, PRE, TAN, WAG); Manampano, Ambodivoanato, Mananjary, *Service Forestier (Rakotomanana) 5100* (TEF); Vohipeno, *Hb. Jard. Bot. Tananarive 6513* (TAN). **Toamasina:** Ile Sainte Marie, Lonkinty, Sahasifotra, Ambohidena Forest, *Razakamalala et al. 447* (B, BM, GH, MO, P, TEF); Tampina forest, *Louvel 197* (P); Vohibola Forest, *Rabehevitra et al. 409* (CAS, F, MO, P, TEF). **Toliara:** Mandena Forestry Station, *Rogers et al. 891* (BM, G, MO, P, TAN, US); Mandromondromotra, N of Fort-Dauphin, *Service Forestier (Capuron) 28646* (P, TEF); Sainte Luce, near Fort-Dauphin, *Falinianina et al. 29* (BM, BR, MO, P, TEF).

4. *Gnidia daphnifolia* L. f., Suppl. Pl. 225. 1782, as “*daphnaefolia*.” *Gnidia daphnifolia* L. f. var. *glabra* L. f., Suppl. Pl. 225. 1782. *Dessenia daphnifolia* (L. f.) Raf., Fl. Tellur. 4: 106. 1838, as “*daphnefolia*.” TYPE: Madagascar. *Hb. Smith No. 688.5* (lectotype, designated by Rogers in Rogers & Spencer, 2006: 486, LINN-SM!). Figure 4.

Dais madagascariensis Lam., Encycl. 2: 254. 1786. Syn. nov. *Lasiosiphon madagascariensis* (Lam.) Decne., Voy. Inde 4: 148. 1844. *Gnidia madagascariensis* (Lam.) Gilg, Nat. Pflanzenfam. 3(6a): 228. 1894. TYPE: Madagascar, s.d., *P. Commerson s.n.* (holotype, P-LA!; isotype, P!).

Dais pubescens Lam., Encycl. 2: 255. 1786. Syn. nov. *Lasiosiphon pubescens* (Lam.) Decne., Voy. Inde 4: 148. 1844. TYPE: Madagascar, s.d., *P. Commerson s.n.* (holotype, P-LA!; isotypes, G [2]!, MA!, P [3]!).

Gnidia rostrata Drake, Hist. Phys. Madagascar 35(5) [Atlas 3], pl. 315. 1896. Syn. nov. TYPE: “Madagascar” (type, pl. 315!, Drake in Grandidier, 1896).

Lasiosiphon rostratus Meisn., Prodr. 14: 597. 1857. Syn. nov. *Lasiosiphon madagascariensis* (Lam.) Decne. var. *rostratus* (Meisn.) Leandri, Bull. Mus. Natl. Hist. Nat. (Paris), sér. 2, 3: 151. 1931. TYPE: Madagascar. Antsiranana: Port Leven, Mar.–Apr. 1849, *L.-H. Boivin 2384* (holotype, G-DC!; isotype, P!).

Lasiosiphon baronii Baker, J. Linn. Soc., Bot. 25: 342. 1890. Syn. nov. *Lasiosiphon madagascariensis* (Lam.) Decne. var. *baronii* (Baker) Leandri, Bull. Mus. Natl. Hist. Nat., sér. 2, 3: 151. 1931. TYPE: Madagascar. NW Madagascar, s.d., *R. Baron 5770* (holotype, K!; isotype, P!).

Lasiosiphon hildebrandtii Scott-Elliot, J. Linn. Soc., Bot. 29: 47. 1891. Syn. nov., non *Lasiosiphon hildebrandtii* Vatke ex Engl., Abh. Konigl. Akad. Wiss. Berlin 2: 310. 1891 [1892], nom. nud. *Gnidia hildebrandtii* (Scott-Elliot) Gilg, Nat. Pflanzenfam. 3(6a): 228. 1894. *Lasiosiphon madagascariensis* var. *hildebrandtii* (Scott-Elliot) Leandri, Bull. Mus. Natl. Hist. Nat., sér. 2, 3: 151. 1931. TYPE: Madagascar. Antsiranana: Montagne

d’Ambre, May 1880, *J. Hildebrandt 3369* (lectotype, designated here, BM!; isotypes, G [3]!, K!, P!, US!).

Lasiosiphon saxatilis Scott-Elliot, J. Linn. Soc., Bot. 29: 46. 1891. Syn. nov. TYPE: Madagascar. Toliara: Sainte Luce, rocky places near Fort-Dauphin, s.d., *G. Scott-Elliot 3030* (holotype, K!; isotype, P!).

Gnidia pubescens Baill., Hist. Phys. Madagascar 35(5) [Atlas 3], pl. 314. 1895, nom. illeg., non *Gnidia pubescens* P. J. Bergius, Descr. Pl. Cap. 124. 1767. TYPE: “Madagascar” (type, pl. 314!, Baillon in Grandidier, 1895).

Lasiosiphon pubescens (Lam.) Decne. var. *multifolius* Leandri, Bull. Soc. Bot. France 76: 1042. 1929 [1930]. Syn. nov. *Lasiosiphon multifolius* (Leandri) Leandri, Notul. Syst. (Paris) 13: 51. 1947. TYPE: Madagascar. Toliara: S Madagascar, Sep. 1900, *C. Alluau 85* (lectotype, designated here, P!).

Lasiosiphon madagascariensis (Lam.) Decne. var. *parvifolius* Leandri, Bull. Mus. Natl. Hist. Nat., sér. 2, 1: 436. 1929 [1930]. Syn. nov. TYPE: Madagascar. Toliara: Ambovombe (Androy), 27 Apr. 1924, *R. Decary 2605* (holotype, P 00380375!; isotype, P!).

Lasiosiphon pubescens (Lam.) Decne. var. *carinatus* Leandri, Bull. Mus. Natl. Hist. Nat. (Paris), sér. 2, 1: 436. 1929 [1930]. Syn. nov. *Lasiosiphon carinatus* (Leandri) Leandri, Notul. Syst. (Paris) 13: 50. 1947. TYPE: Madagascar. Toliara: Ambovombe, along ocean, calcareous limestone and sand, 8 May 1924, *R. Decary 2694* (holotype, P!; isotypes, P!, TAN!).

Lasiosiphon madagascariensis (Lam.) Decne. var. *angustifolius* Leandri, Bull. Mus. Natl. Hist. Nat., sér. 2, 3: 151. 1931. Syn. nov. TYPE: Madagascar. Antsiranana: Vohémar, 1840, *J. Richard 580* (lectotype, designated here, P!).

Lasiosiphon waterlotii Leandri, Bull. Mus. Natl. Hist. Nat., sér. 2, 3: 153. 1931. Syn. nov. TYPE: Madagascar. Antsiranana: Ambilobe, s.d., *E. Waterlot 331* (holotype, P!).

Lasiosiphon dumetorum Leandri, Notul. Syst. (Paris) 13: 52. 1947. Syn. nov. TYPE: Madagascar. Toliara: Manambolo Valley, Mandrare basin, near the Isomono (confluence of the Sakamalio), Mt. Morahariva, 1000–1400 m, Dec. 1933, *H. Humbert 13242* (lectotype, designated here, P!; isotypes, BM!, G!, K!, TAN!, US!).

Lasiosiphon madagascariensis (Lam.) Decne. var. *mandrarensis* Leandri, Notul. Syst. (Paris) 13: 47. 1947. Syn. nov. TYPE: Madagascar. Toliara: Manambolo Valley, Mandrare basin, near the Isomono (confluence of the Sakamalio), Mt. Morahariva, 1000–1400 m, Dec. 1933, *H. Humbert 13154* (lectotype, designated here, P 00380344!; isotypes, BM!, G!, K!, P [2]!, TAN!, US!).

Lasiosiphon suffrutescens Leandri, Notul. Syst. (Paris) 13: 45. 1947. Syn. nov. TYPE: Madagascar. Toliara: Manambolo Valley, Mandrare basin, near the Isomono (confluence of the Sakamalio), Mtns. Kotriha & Isomonobe, 400–600 m, Dec. 1933–Jan. 1934, *H. Humbert 12844* (holotype, P 00370336!; isotypes, BM!, G [2]!, K!, MO!, P!, TAN!, US!).

Shrubs or trees to 6 m tall; young branches densely to moderately pubescent; mature branches sometimes lenticellate. **Leaves** alternate, rarely subopposite, petiolate; petioles 1–2(–3) mm, densely to moderately pubescent; blades broadly obovate or obovate-elliptic, rarely narrowly elliptic, 7–61 × 4–21 mm, l:w ratios

ca. 3–5(–7):1, often slightly inequilateral, both surfaces usually strigose or tomentose initially before becoming glabrescent, sometimes densely pubescent (but indument never dense enough to hide the adaxial surface), apex acute, rounded, or obtuse, tip usually apiculate, base attenuate, less often cuneate; midrib depressed or rarely plane adaxially, raised and pubescent abaxially; venation often discolorous, usually raised on both surfaces, more pronounced abaxially. **Inflorescences** terminal or axillary, sometimes extra-axillary, erect, involucrate, (8- to)11- to 35-flowered; peduncles 3–50 mm, densely to sparsely pubescent, rarely glabrescent; involucral bracts 5, generally broadly ovate (often 1 or 2 bracts within inflorescence with a broader base and shorter acumen or rostra), (3–)5–19 × (2–)5–6 mm, l:w ratios ca. 2–4:1, persistent, lower half of bracts appressed to flowers, glabrous to densely pubescent on both surfaces, apex usually rostrate or long-acuminate, less often short-acuminate, acumen or rostra to 1.1 cm when present, upper half often reflexed when longer (but never apically decurved), base rounded-truncate; nervation conspicuous near margin. **Flowers** 5-merous, yellow, orange, or red; pedicels (0.2–)0.5–1.5 mm, covered with 1.5–3 mm trichomes; hypanthium 6.5–12(–15) mm, articulate, densely pubescent externally, usually glabrescent internally; caducous portion densely covered externally with ca. 0.5 mm trichomes; persistent portion (2.5–)3–4 mm, densely covered externally with (1.5–)2.5–4 mm trichomes that obscure the surface in fruit; calyx lobes 5, broadly elliptic, obovate, or ovate, 1.2–3.5 × 1–2.3 mm, glabrous adaxially, densely pubescent abaxially, apex emarginate or rounded; petaloid scales 5, narrowly ovate-elliptic or obovate, sometimes approaching linear or orbicular, 0.8–1.4 × 0.2–1.3 mm, membranous, glabrous, apex acute to rounded, emarginate, or with a few rounded lobes, sometimes with a conspicuous dark midvein; stamens 10, upper whorl of anthers located just below mouth or to 3/4 exerted, lower whorl 1–1.5 mm below upper whorl; anthers elliptic, 0.6–1.1 × 0.2–0.3 mm, subsessile; subgynoecial disk cupuliform, 0.1–0.4 mm tall, glabrous, fleshy, apex smooth or irregularly lobed; ovary ellipsoid, ca. 1.3 × 0.6 mm, sessile or shortly stipitate (stipe to 0.2 mm), mostly glabrescent, apex sometimes moderately pubescent; style to 12 mm, glabrous; stigma ca. 2 mm below or at height of lower whorl of anthers. **Fruits** ellipsoid, 2.3–4 × 1–1.5 mm, usually glabrous, sometimes with a few sparse trichomes near apex.

Distribution and habitat. *Gnidia daphnifolia* is widespread in Madagascar from 0–1400 m elevations, with most populations occurring either in the drier areas of the far north, or in the humid regions of the

southeast (Fig. 15). Several disjunct populations (e.g., at Ankara Plateau, Tampoketsa d'Ankazobe, Tsiribihina Valley, Fanjahira) scattered along the central and occidental side of the high plateau link the disjunct northern and southern populations. The species occurs in degraded open savannas on sandy or lateritic soils, and is less frequently found on rocky slopes of granite, gneiss, limestone, and possibly marble.

Phenology. The species flowers and fruits year round.

Vernacular names. Avoha (Decary 4030; Humbert 20403); avoha madinika (Cloisel 135); havoa (Randraiatafika 349); havoha (Réserves Naturelles 13004); mandrakieka (Service Forestier [Serrado] 1282); mandreankaine (Bernier 157); mandriankiaka (Guittou et al. 4; Luckow 4226); tsifoladrivotra (Rogers & Rakotonasolo 147).

IUCN Red List category. *Gnidia daphnifolia* is widespread and common throughout Madagascar and has been recorded in at least several protected areas (e.g., Andohahela, Ankarana, Tsaratanana). The species is assigned a provisional IUCN (2001) conservation status of Least Concern (LC).

Discussion. *Gnidia daphnifolia* is the most geographically widespread and morphologically variable species of *Gnidia* in Madagascar. The substantial morphological variation in this taxon is probably due to the wide array of biophysical parameters (e.g., elevation, substrate, bioclimate, habitat) affecting the various populations that occur throughout a broad geographic distribution (Fig. 15, ▲). Plants, even within a single population, are capable of exhibiting a large amount of morphological variation, especially in those features (e.g., leaf and bract size and pubescence, peduncle length, hypanthium length) that were previously considered taxonomically important in various treatments of the group (Leandri, 1931a, b, 1947, 1950). Furthermore, most of Leandri's taxa were based on the examination of relatively few specimens made from disjunct localities that did not show the morphological overlap and continuous variation in the characters he deemed diagnostic. As a result, 13 of Leandri's names (five at the specific and eight at the varietal rank) are now placed into synonymy with *G. daphnifolia*.

Gnidia daphnifolia can be distinguished from similar Malagasy species (e.g., *G. gilbertae*, *G. hibbertioides*, *G. linearis*, *G. occidentalis*) by a combination of features, including its relatively wide leaves (reaching 21 mm wide) that are generally broader above the midpoint, the involucrate inflorescences usually borne on long peduncles (to 5 cm

long), the involucral bracts typically with a long rostrate or acuminate apex, the articulated hypanthium with five calyx lobes, and the petaloid scales measuring 0.8–1.4 × 0.2–1.3 mm.

Outside of Madagascar, *Gnidia daphnifolia* differs from the widespread *G. glauca*, a species distributed roughly from central Africa to southern India (Peterson, 2006), by its inflorescences with five (vs. six to 12) involucral bracts, the articulated (vs. unarticulated) hypanthium, and the leaves with fewer secondary and intersecondary veins.

Nomenclature and typification. The validly published name, *Gnidia daphnifolia* (Linnaeus, 1782), has usually been treated in the literature as a synonym of either *Lasiosiphon madagascariensis* or *L. pubescens*, combinations both based on *Dais* basionyms originally published by Lamarck (1786) that were later transferred to *Lasiosiphon* by Decaisne (1844). Meisner (1857: 597) was probably the first author to formally treat *G. daphnifolia* as pro parte synonyms of *L. madagascariensis* and *L. pubescens*, respectively, but Gilg (1894: 228) appears to have been the first person to resurrect the Linnaean *G. daphnifolia*. Leandri (1931b: 149), in his first revision of the Malagasy *Gnidia*, incorrectly placed *G. daphnifolia* L. f. into synonymy with *G. bojeriana*. These two taxa are difficult to confuse and thus he might have actually been referring to “*G. daphnaefolia*,” a manuscript name of Bojer’s that appeared as a synonym in the protologue of *L. bojerianus* (Decaisne, 1844: 149). Strangely, Leandri did not mention *G. daphnifolia* L. f. in his second revision of the group (1947) nor in his *Flore de Madagascar et des Comores* treatment (1950). Whatever the case, Leandri certainly did not consult the original Linnaean material used to describe *G. daphnifolia* that is still extant in the Smith Herbarium at LINN and was recently designated as the lectotype of the name in Rogers and Spencer (2006).

Two collections were cited in the protologue of *Lasiosiphon hildebrandtii* (Scott Elliot, 1891): *Hildebrandt 3369* (BM, G [3], K, P, US) from far northern Madagascar and *Scott-Elliot 2368* (BM, K, P) from extreme southern Madagascar. The Hildebrandt collection more closely matches the protologue description and the BM sheet is chosen as the lectotype.

Two collections, *Alluaud 85* and *Alluaud 106*, were cited in the protologue of *Lasiosiphon pubescens* var. *multifolius*, both of which are deposited at P and match the original description (Leandri, 1930a). *Alluaud 85* (P) is selected as the lectotype because the original label bears Leandri’s handwritten annotation of the name. The other syntype is in equally good condition and instead bears Leandri’s annotation on a typewritten Paris herbarium label.

Two collections are cited in the protologue of *Lasiosiphon madagascariensis* var. *angustifolius* (Leandri, 1931b): *Perrier de la Bâthie 1276* and *Richard 580*. Later, Leandri (1947) went on to use *Perrier de la Bâthie 1276* as one of five syntypes for *L. occidentalis* (\equiv *Gnidia occidentalis*). In the *Flore*, Leandri (1950) did not recognize his variety *angustifolius* and instead cited *Richard 580* under the species *L. madagascariensis*. Thus, *Richard 580* more closely matched Leandri’s concept of *L. madagascariensis* var. *angustifolius*, and the sheet deposited at P is chosen as the lectotype.

Five collections of *Lasiosiphon dumetorum* were cited in the protologue (Leandri, 1947): *Humbert 6742* (G [2], P), *12812bis* (P), *13010* (P), *13242* (BM, G, K, P, TAN, US), *13800* (P). All examined specimens match the description, but *Humbert 13242* is the most widely distributed collection and the P sheet is selected as the lectotype.

Three collections were cited in the protologue of *Lasiosiphon madagascariensis* var. *mandrarenensis* (Leandri, 1947): *Humbert 13154* (BM, G, P [3], TAN, US), *13860* (P), *14053* (P). All three closely match the description. *Humbert 13154* is the most widely distributed collection and P 00380344 is selected as the lectotype.

Selected specimens examined. MADAGASCAR. **Antananarivo:** Angavo massif, near Ankazobe, *Decary 7353* (P); Antananarivo–Majunga rd., Km 184, *Descoings 3283* (MO, TAN); Vohimbohita massif, near Manakana, *Cours (Hb. St. Agric. Alaotra) 1518* (MO, P, TAN). **Antsiranana:** Ambilobe, SW of Ambilobe, *Humbert & Capuron 25579* (P); Analabe forest, near village of Analabe & Lac Sahaka, Fivondronana Vohémar, *Razakamalala et al. 538* (BR, MO, P, TEF); Analamazava, part of Binara Range, SW of Daraina (Vohémar), *Meyers 17* (MO, P, TAN); Analamera, calcareous hills & plateau, *Humbert 19145* (P); Anivorano Avaratra, Lac Sacré, near Anivorano-Nord, *Humbert 32321* (MO, P); Ankarana Special Reserve, *Rogers & Rakotonasolo 155* (MO, P, TAN); Babaomby Forest, Firaisana Ramena, *Rabenantoandro & Razantsoa 598* (MO, P, TAN); Irodo forest, *Seigler 12881* (MO, TAN); Iovovona, Diego Suarez–Orangea rd., *Rogers & Rakotonasolo 149* (G, MO, P, TAN); Joffreville, 2 km SE of Joffreville on rd. from Diego Suarez to Montagne d’Ambre Natl. Park, *Rogers & Rakotonasolo 147* (MO [3]); Montagne d’Ambre, Les Roussettes at Ankazobe, *Homolle 167* (P); Montagne des Français, 6–8 km N of Diego Suarez, *Rogers & Rakotonasolo 133* (MO, TAN); Port Leven, *Boivin 2384* (G, P); Vovo Village Distr., *Harder 1665* (MO, TAN). **Mahajanga:** Ankara massif, *Decary 14524* (BM, K, P, US); Ikopa valley, W of Ankazobe, *Decary 7676* (G, P); Masokoamena, Tampoketsa Masokoamena, *Perrier de la Bâthie 8552* (P [2]); Masokoamena, Bemarivo, *Perrier de la Bâthie 8548* (P). **Toliara:** Amboasary, 1 km E of town, *Rogers et al. 914* (G, K, MO, P, TAN, US); Ambovombe, *Decary 8391* (MO, P); Andohahela Natl. Park (Parcel #1), 200 m N of Mahamavo village, *Rogers & Rakotonasolo 110* (MO, TAN); Andriamanga, Lac Mananivo, *Dumetz et al. 614* (K, MO, TAN, TEF, WAG); Andriambe, above Belavenoky River, *Rogers et al. 954* (B, G, K, MO, P, TAN, US); Ebakika, N of Fort-Dauphin, *Decary 10102* (MO, P, US); Emena

village (Andohahela Natl. Park [Parcel #1]), *Réserves Naturelles (Randriamiera) 13004* (TEF); Fanjahira, plateau & valley of Isalo, *Humbert 2755* (P); Fort-Dauphin, *Decary 4030* (P, TAN); Fort-Dauphin, rocky places in open country, *Scott-Elliott 2368* (BM, K, P); Kotriha, Mandrare basin, Mtns. Kotriha & Isomonobe, *Humbert 12812bis* (P); Imonty, Mananara basin, betw. the Andohahela & Elakelaka, *Humbert 14053* (P); Imonty, Canton Behara, Distr. Androy, *Réserves Naturelles (Ramarokoto) 2312* (P [2], TAN); Mahamavo, Mananara basin, *Humbert 13800* (P); Mahatalaky, 3–4 km S of Mahatalaky village, *Randrianasolo 571* (BM, G, MO, P, TAN); Manambolo Valley, Mandrare basin, *Humbert 6742* (G [2], P); Manantenina, N of Fort-Dauphin, *Decary 3897* (P, TAN); Morahariva, Manambolo Valley, Mandrare basin, *Humbert 13154* (BM, G [3], TAN, US), *13242* (BM, G, K, P, TAN, US), *13860* (P); Nosibe, ca. 5 km E of Manambaro, *Rogers et al. 906* (G, K, MO, P, TAN); Pic Saint Louis, near Fort-Dauphin, *Rogers & Rakotonasolo 106* (K, MO [2], P); Ranopiso, 6 km W of Ranopiso village, *Croat 31930* (MO, TAN); Sakamalio, Manambolo Valley, Mandrare basin, Isomono, *Humbert 13010* (P); S Madagascar, *Alluaud 106* (P); Tsiribihina, betw. Soahanina & Tsiribihina, *Perrier de la Bâthie 8551* (P).

5. *Gnidia decaryana* Leandri, Bull. Mus. Natl. Hist. Nat., sér. 2, 1: 436. 1929 [1930]. TYPE: Madagascar. Toliara: Fort-Dauphin, 3 July 1926, *R. Decary 4332* (holotype, P 00373426!; isotypes, P!, TAN!). Figure 5.

Shrubs to 2 m tall; young branches reddish when fresh, flattened (more pronounced near internodes), densely to moderately pubescent, covered with prominent leaf scars; mature branches lenticellate. **Leaves** opposite to decussate, pairs rarely alternate on vigorous shoots, appressed adaxially against stems, caducous on older branchlets; petioles 0.4–0.8 mm, glabrescent to moderately pubescent; blades obovate to suborbicular, (4.1–)8–15(–18) × (2–)5–11 mm, l:w ratios ca. 1–2.5:1, both surfaces glabrous, lighter green or brown abaxially, apex apiculate, obtuse or rounded, margin with a distinct vein that appears red on young leaves when fresh, base cuneate to attenuate; midrib slightly depressed adaxially, glabrous or sparsely pubescent, raised and glabrescent abaxially, or with a few sparse strigose trichomes, lighter green than blade abaxially; secondary venation glabrous, raised or inconspicuous adaxially, usually conspicuous and more pronounced abaxially. **Inflorescences** terminal or axillary, erect, capitate, 2- to 4-flowered, sessile or subsessile, subtended by 2 pairs of closely spaced decussate bracts, the upper pair smaller and caducous. **Flowers** 4-merous, red-green, green-white, or yellow?, subsessile; pedicels 0.4–0.8 mm, densely pubescent; hypanthium 6.1–9 mm, articulate, ± membranous, densely pubescent externally, trichomes to 0.3 mm, trichomes of similar length on both portions or slightly longer on the persistent portion, glabrescent or sparsely pubescent

in lower half near articulation internally; caducous portion becoming light brown in fruit when fresh; persistent portion 2.5–3 mm; calyx lobes 4, spreading, broadly elliptic or orbicular, 1.4–1.9 × 1.4–1.9 mm, one opposing pair smaller, glabrescent or sparsely puberulent adaxially, tomentose on lower half abaxially, otherwise glabrous, apex rounded or obtuse; petaloid scales absent; stamens 8, upper whorl of anthers ca. 1/4 exerted, lower whorl 0.2–0.5 mm below upper whorl; anthers elliptic, 0.6–0.8 × 0.2 (–0.3) mm, subsessile; subgynoecial disk cupuliform or absent, to 0.1 mm tall, glabrous, apex irregularly lobed to nearly entire; ovary ovoid to ellipsoid, 0.9–1.1 × 0.4–0.5 mm, sessile or very shortly stipitate (stipe to 0.1 mm), lower half densely to sparsely pubescent, rarely glabrescent, upper half densely to sparsely pubescent, apex always densely pubescent with 1–1.5(–2) mm trichomes; style 2.2–6 mm, sparsely to moderately strigose, rarely glabrescent; stigma ca. 1.5 mm below lower whorl of anthers. **Fruits** ovoid-ellipsoid or ellipsoid, 3.1–3.4 × 1.3–1.5 mm, sparsely to moderately pubescent, apex usually densely pubescent.

Distribution and habitat. *Gnidia decaryana* occurs in southeastern Madagascar near Fort Dauphin (Toliara Province) from sea level to 950 m elevation (Fig. 17). The species grows in open sunlit areas and has been recorded on sand and gneiss in the humid bioclimatic zone.

Phenology. The species has been found in flower and fruit in January, March, July, October, and December.

IUCN Red List category. *Gnidia decaryana* occurs within the boundaries of one protected area (Andohahela). In 2003, a small, unprotected population of *G. decaryana* was located growing on the outskirts of Fort Dauphin along the base of the Pic St. Louis, bordering agricultural fields and no more than 25 m away from the edge of the town (Rogers, pers. obs.). The species is assigned a provisional IUCN (2001) conservation status of Near Threatened (NT).

Discussion. *Gnidia decaryana* is distinguished from *G. neglecta*, the most morphologically similar Malagasy species, by its obovate to suborbicular blades with cuneate to attenuate bases (vs. broadly ovate blades with cordate bases), a different venation pattern, its sessile or subsessile (vs. pedunculate) inflorescences, and by the dense (vs. completely absent) pubescence on the outer surface of the hypanthium. In addition, populations of *G. decaryana* occur more than 600 km to the south of *G. neglecta*.

Gnidia subcordata Meisn., an African species in the closely related segregate genus *Englerodaphne* (as *E. subcordata* (Meisn.) Gilg), differs from *G. decaryana* by

its pedunculate (vs. sessile or subsessile) inflorescences, longer flowers (11–15 mm vs. 6.1–9 mm long), and sparsely pubescent (vs. densely pubescent), \pm funnel-shaped (vs. cylindrical) hypanthium.

The inflorescence structure of *Gnidia decaryana* (Fig. 5B) is unique within the Malagasy species, with its two pairs of decussately arranged foliose bracts, located directly below two to four sessile or subsessile flowers. The bracts closest to the flowers are usually about half the size of the lower pair and fall off earlier. A clear distinction between leaf and bract, if one can be made, is definitely blurred in this species. One small membranous bracteole subtends each flower and lacks obvious nervation and will rarely persist until anthesis.

Typification. Two sheets of *Decary 4332* are deposited at P. Both sheets closely match the description in the protologue (Leandri, 1930b: 436) and were annotated by Leandri. The sheet bearing the accession number P 00373426 has the locality and date cited in the protologue and is regarded as the holotype.

Selected specimens examined. MADAGASCAR. **Toliara:** Andohahela, Mananara basin, mtns. betw. Andohahela & Elakelaka, Mahamavo, *Humbert 13884* (G, P [2], TAN); Imonty, Mananara basin, mtns. betw. Andohahela & Elakelaka, S of Imonty, *Humbert 14084* (P); betw. Mandromondromotra & Lokaro, N of Fort-Dauphin, *Service Forestier (Capuron) 28650* (MO, P, TEF); Pic Saint Louis, *Rogers & Rakotonasolo 108* (BM, G, MO, P, TAN, WAG).

6. *Gnidia gilbertae* Drake, Bull. Mens. Soc. Linn. Paris 2: 1218. 1896. TYPE: Madagascar. Mahajanga: betw. "Madounga et Antsalahanki," 1876, *A. Grandidier s.n.* (holotype, P!). Figure 6.

Shrubs or trees to 4 m tall; young branches pubescent; mature branches not lenticellate. **Leaves** alternate, rarely subopposite, leaves crowded near branch tips, rarely persistent on older branchlets; petioles 0–2(–3) mm, densely pubescent or glabrescent; blades broadly obovate to nearly elliptic, 1.4–5.5 \times 0.4–1.7 cm, l:w ratios 2.3–3.6:1, both surfaces moderately to sparsely pubescent, rarely densely pubescent, apex rounded or emarginate, tip usually apiculate, base attenuate or less often cuneate; midrib depressed or rarely plane adaxially, raised and densely pubescent abaxially; venation often discolorous, usually raised on both surfaces, more pronounced abaxially. **Inflorescences** terminal or rarely axillary, erect, involucrate, 16- to 28-flowered; peduncles 0.5–5(–9) mm, densely pubescent; involucre bracts 4(5), broadly ovate or orbicular, 7–12 \times 4–7 mm, l:w ratios 1.1–2.6:1, chartaceous, erect, persistent, usually glabrescent adaxially, rarely sparsely or densely strigose in upper half abaxially, apex short-acuminate or acute, acumen to 3 mm, spreading (i.e., not

reflexed), base rounded-truncate; midrib inconspicuous or visible on both surfaces, more pronounced abaxially; nervation often conspicuous on both surfaces and represented by 2 or 4 veins, those more obvious near the margin. **Flowers** 4-merous, yellow or orange; pedicels 0.5–1(–1.5) mm, densely covered with 0.5–1 mm trichomes; hypanthium (10–)12.5–17 mm, unarticulated, coriaceous, densely pubescent externally, trichomes (0.5–)1–1.5 mm, usually glabrescent internally; caducous portion torn irregularly in the lower 1/3 by the developing fruit; calyx lobes 4, broadly elliptic-oblong or obovate, 2.1–2.7 \times 1.2–1.4 mm, glabrescent or sparsely puberulous adaxially, densely pubescent abaxially, apex emarginate or rounded; petaloid scales 4, narrowly ovate-elliptic, 0.9–1.2 \times 0.2–0.3(–0.5) mm, membranous, glabrous, apex acute or with 1 to several irregular rounded lobes, often with a conspicuous midnerve when dry; stamens 8, upper whorl of anthers just below mouth, lower whorl ca. 1–1.5 mm below upper whorl; anthers elliptic-oblong, 0.8–0.9 \times ca. 0.2 mm, subsessile; subgynoecial disk cupuliform, 0.2–0.4 mm tall, glabrous, fleshy, apex smooth or slightly lobed; ovary ellipsoid, 1.2–1.6 \times 0.4–0.7 mm, stipitate (stipe ca. 0.2 mm), glabrous; style 3.4–5.7 mm, glabrous; stigma 0–7 mm below lower whorl of anthers. **Fruits** ellipsoid, 2.9–3.1 \times 1.1–1.2 mm, glabrous or rarely with a few sparsely spaced trichomes at the apex.

Distribution and habitat. *Gnidia gilbertae* is endemic to semi-deciduous gallery forests in northwestern Madagascar (Mahajanga Province) from ca. 100–250 m elevation (Fig. 16). The species occurs in open sunlit areas on sandy substrates in Madagascar's dry bioclimatic zone.

Phenology. The species flowers and fruits from April through November.

Vernacular names. Famoty (*Réserves Naturelles [Harizo] 1022*); sisitry (*Réserves Naturelles [Rakotavao] 4234*); tzomangamena (*Randrianaivo et al. 614*).

IUCN Red List category. *Gnidia gilbertae* has been recorded in two formally protected areas (Ankarafantsika, Namoroka). The species has also been collected, both frequently and recently, at Ampijoroa and Ankarafantsika. The species is assigned a provisional IUCN (2001) conservation status of Least Concern (LC).

Discussion. *Gnidia gilbertae* is distinguished from *G. daphnifolia* by the 4- (vs. 5-)merous flowers, the hypanthium that lacks an articulation and is instead torn irregularly in the lower 1/3 by the developing fruit, the leaves that usually only remain persistent near the tips of the branches (vs. leaves persistent

along most of the stem), the four or rarely five (vs. five) involucre bracts, and the generally shorter peduncles 0.5–5(–9) mm vs. 3–50 mm long.

Selected specimens examined. MADAGASCAR. **Mahajanga:** Ampijoroa Forest Station, *Phillipson 1936* (K, MO, P, TAN, WAG); Anjiafitatra [Tsitondroina], *Réserves Naturelles (Randrianasolo) 2180* (P, TAN); Anjiamangirana, near village of Analanambe, *Ranaivojaona et al. 314* (BM, G, MO, P, TAN); Ankarafantsika Plateau, June 1928, *Lavauden s.n.* (P); Ankirihitra, near Mt. Tsitondroina at Ankirihitra, *Perrier de la Bâthie 998* (P); Bongalava, *Bisset M3* (K); Namoroka, *Réserves Naturelles 9701* (P, TEF); Port Bergé, Bongalava, dry forest of Marosely, *Razakamalala et al. 1742* (G, MO, P, TEF, US); Tsitampiky [Sitampiky], *Decary 8181* (P, TAN).

7. *Gnidia gnidioides* (Baker) Domke, *Biblioth. Bot.* 27 (111): 46. 1934. Basionym: *Dais gnidioides* Baker, *J. Linn. Soc., Bot.* 20: 244. 1883. *Gnidia bakeri* Gilg, *Nat. Pflanzenfam.* 3(6a): 227. 1894, nom. superfl. *Arthrosolen gnidioides* (Baker) Leandri, *Bull. Soc. Bot. France* 76: 1043. 1929 [1930]. TYPE: Madagascar. Antananarivo: "grassy hills of the province of Imerina," s.d., *R. Baron 2061* (lectotype, designated here, K!; isotype, P!). Figure 7.

Shrubs to 80 cm tall, branching subequally (di-)trichotomously, sometimes one shoot in trichotomy does not elongate; branches not lenticellate, orange-red when fresh, usually dark red after drying, densely to sparsely strigose or strigose-tomentose, indument denser near branch tips. **Leaves** alternate, rarely subopposite, usually persistent on older branchlets, erect, drying subappressed or appressed to stems adaxially, subsessile; petioles to 0.8 mm, densely to sparsely strigose; blades needle-shaped, rarely very narrowly obovate or ovate, 7–19 × 0.75–2(–3) mm, l:w ratios (4.5–)6–15:1, involute, ± coriaceous, both surfaces sparsely strigose to glabrescent (indument more obvious near base and along midrib), apex acute or short-acuminate, tip rounded or rarely apiculate, base cuneate or attenuate; midrib inconspicuous or slightly raised adaxially, plane or slightly raised abaxially; venation inconspicuous adaxially, abaxially represented by 2 or 4 longitudinal plicate veins when dry. **Inflorescences** terminal, erect, subsessile, globose, resembling composite-like heads (composed of many closely arranged clusters of bracteate flowers), ca. 50- to 100-flowered, to 2.8 cm diam.; peduncles 0.5–3 mm, densely to moderately pubescent; bracts surrounding the base of the head 5 to 7, imbricate, spreading, persistent, broadly ovate or less often narrowly elliptic-ovate, 5–10.2 × 1.5–4.6 mm (various dimensions within the inflorescence), ± coriaceous or membranous, densely pubescent to

glabrescent, apex acuminate to aristate, acumen or arista to 4 mm, margin densely ciliate, base cuneate or attenuate-truncate; midrib and nervation conspicuous; bracts within the head 50 or more, subtending floral clusters, imbricate, persistent, broadly elliptic-obovate to linear-elliptic, 3.2–5.2 × 0.5–2 mm (various dimensions within the inflorescence), chartaceous-membranous, scabrous, densely to sparsely pubescent adaxially, glabrous to densely pubescent abaxially, apex acute or slightly acuminate, margin densely ciliate, base cuneate or attenuate; midrib and nervation conspicuous. **Flowers** 4-merous, pink, red, white?, or yellow?; pedicels 0.4–0.7 mm, covered by a dense brush of 3–4 mm trichomes; hypanthium 6.5–10 mm, articulate; caducous portion ± membranous, densely covered with erect indument externally, trichomes 1–1.5 mm, glabrous internally; persistent portion ca. 2 mm, membranous, glabrous externally and internally; calyx lobes 4, erect, white-pink, red, or yellow, broadly oblong or elliptic, 1–2.2 × 0.5–1.3 mm, glabrous adaxially, densely to moderately pubescent abaxially, apex rounded, truncate, or emarginate; petaloid scales absent; stamens 8, upper whorl of anthers just below mouth, lower whorl 0.1–0.5 mm below upper whorl; anthers elliptic, 0.4–0.6 × 0.15–0.2 mm, subsessile; subgynoecial disk cupuliform or absent, less than 0.1 mm tall when present, glabrous, fleshy, apex smooth or irregularly lobed; ovary ellipsoid, 0.7–1.1 × 0.3–0.5 mm, sessile, glabrous; style 3–4.7 mm, glabrous; stigma 0–2.5 mm below the lower whorl of anthers. **Fruits** ellipsoid, 1.6–1.9 × 0.9–1 mm, glabrous. *n* = 9 (Rabakonandrianina & Carr, 1987).

Distribution and habitat. *Gnidia gnidioides* occurs on the central plateau of Madagascar from 1000–2500 m elevation (Fig. 17). Populations occur from the Tampoketsa of Ankazobe (a region located to the north of Antananarivo) to the Andringitra massif. *Gnidia gnidioides* is associated with marshy areas and other moist places, and grows in open sunlit areas, including prairies and *Tapia* woodlands, in the subhumid bioclimatic zone. Some specimen labels mention that the species occurs on gneiss or quartzitic rocks.

Phenology. The species flowers and fruits year round.

Vernacular name. Bambola (*Réserves Naturelles [Razafindrakoto] 3055*, *Réserves Naturelles [Rabevazaha] 10387*; *Service Forestier [Marlange] 1950*).

IUCN Red List category. *Gnidia gnidioides* is common in both protected (Ambohitantely, Andringitra, Analamazoatra) and unprotected areas, at least some of which are periodically disturbed by fire

(Rogers, pers. obs.). The species is assigned a provisional IUCN (2001) status of Least Concern (LC).

Discussion. *Gnidia gnidioides* is easily distinguished by its needle-shaped leaves and 50- to 100-flowered, terminal, subsessile inflorescences that superficially resemble composite-like heads. The species is most morphologically similar to two continental African species, *G. bambutana* (Cameroon, Nigeria) and *G. mollis* (Congo-Kinshasa, Malawi, Mozambique, Tanzania, Zambia). Based on a study of the inflorescence architecture of all three species, Aymonin (1966c) found that *G. gnidioides* differs from *G. bambutana* by its fewer-flowered floral clusters within the head and its more coriaceous and thicker leaves. Examined specimens of *G. mollis* are similar to *G. gnidioides*, but tend to have broader leaves, larger inflorescences, and flowers with petaloid scales. Robyns (1975) in the *Flore d'Afrique Centrale* and Peterson (1978) in the *Flora of Tropical East Africa* noted that the three species are closely related, but considered each one to belong to a distinct species. It should be noted that the basionym of *G. gnidioides* (*Dais gnidioides* Baker, 1883) would have priority over *G. mollis* (Wright, 1906) and *G. bambutana* (Engler, 1921) if future studies indicate that these three taxa are conspecific.

Nomenclature and typification. The superfluous name *Gnidia bakeri* Gilg has been used incorrectly to refer to *G. gnidioides* as recently as the *Flore de Madagascar et des Comores* (Leandri, 1950). Baker (1883) originally described the species as *Dais gnidioides*, but Gilg (1894) chose not to retain the epithet when transferring the species to *Gnidia*. Leandri (1930a) transferred the species using the correct epithet (*gnidioides*) into *Arthrosolen*, a genus now widely considered to be synonymous with *Gnidia*. Later Domke (1934) created a combination for the species in *Gnidia* also using Baker's original epithet. In the *Flore*, Leandri (1950) placed both *A. gnidioides* and *D. gnidioides* into synonymy under the illegitimate name *G. bakeri* Gilg.

Two collections (*Baron 665*, *Baron 2061*) were cited in the protologue of *Dais gnidioides* (Baker, 1883). The K sheet of *Baron 2061* is selected as the lectotype to avoid any potential ambiguity caused by the fact that the only material of *Baron 665* at K was mounted on the same sheet as *Baron 1894*, and consequently might represent a mixed gathering.

Selected specimens examined. MADAGASCAR. **Antananarivo:** Ambohitantely Special Reserve, *Rogers et al. 126* (G, K, MO, P, WAG); Analabe swamp, *Cours (Hb. St. Agric. Alaotra) 1797* (MO, P, TAN); Betafo, *Perrier de la Bâthie 8541* (P); betw. Ambatolampy & Tsinjoarivo, *Viguiier 1800* (P)

[2]); Central Madagascar, *Baron 665* (K); Km 30 on rd. betw. Antananarivo & Ambatolampy, *Keraudren & Aymonin 25160* (P); Mandraka forests, *D'Alleizette 1110* (P). **Fianarantsoa:** Andringitra massif, *Réserves Naturelles (Razafindrakoto) 2271* (GH, K, MO, P [2]); Ankarabe, *Rauh 79* (TAN); Fenoarivo, *Bosser 413* (TAN); Ibity massif, *Fosberg 52380* (US); Itremo massif, *van der Werff & McPherson 13577* (G [2], MO, TAN, WAG). **Toamasina:** Antsahapandrano (Ankaraha), *Decary 17646* (K, P).

8. *Gnidia hibbertioides* (S. Moore) Z. S. Rogers, comb. nov. Basionym: *Lasiosiphon hibbertioides* S. Moore, *J. Bot.* 58: 189. 1920. TYPE: Madagascar, s.d., *J. Thompson & J. Forbes s.n.* (holotype, BM!). Figure 8.

Shrub?; young branches densely pubescent. **Leaves** alternate, closely arranged, caducous on older branchlets; petioles 1–2 mm, densely pubescent; blades narrowly elliptic or slightly obovate, 1.5–2.2 cm × 3–4 mm, l:w ratios ca. 4–6:1, involute, both surfaces covered with a dense uniform indument of ca. 0.5 mm, erect to subappressed, trichomes, apex apiculate, base long-attenuate; midrib inconspicuous adaxially, raised abaxially, densely to moderately pubescent on both surfaces; venation ± inconspicuous. **Inflorescences** terminal, erect, involucre, ca. 7-flowered; peduncles to 3 mm, densely pubescent; involucre bracts 5, broadly ovate-elliptic, 1–1.2 cm × 3–4 mm, l:w ratios ca. 3:1, similar in texture to leaves, erect, glabrous adaxially, densely pubescent abaxially, apex acute or apiculate, base obtuse-rounded; midrib and nervation inconspicuous on both surfaces. **Flowers** 5-merous, sessile or subsessile; pedicels to 0.5 mm, densely covered with ca. 2 mm trichomes; hypanthium 1.7–1.9 cm, articulate; caducous portion densely pubescent externally, trichomes ca. 0.5–1 mm, glabrous or with a few appressed trichomes near articulation internally; persistent portion 5–7 mm, externally covered by 1.5–2 mm trichomes, those erect and nearly perpendicular to the surface of the tube, glabrous internally; calyx lobes 5, narrowly ovate-subtriangular, 4–5.2 × 1.5–1.6 mm, glabrous adaxially, densely pubescent abaxially, apex acute; petaloid scales 5, suborbicular or very broadly ovate, 4.6–6 × 3.8–4.7 mm, membranous, glabrous, upper half with an irregularly lacerate or sinuate margin; stamens 10, upper whorl of anthers located just below mouth, lower whorl ca. 3.5 mm below upper whorl; anthers oblong, 1.2–1.4 × ca. 0.25 mm, subsessile; subgynoecial disk cupuliform, ca. 0.5 mm tall, glabrous, apex smooth or irregularly lobed; ovary ellipsoid, ca. 1.2 × 0.5 mm, stipitate (stipe ca. 0.4 mm), mostly glabrous, apex with a few trichomes; style and stigma not seen in good condition. **Fruits** not seen.

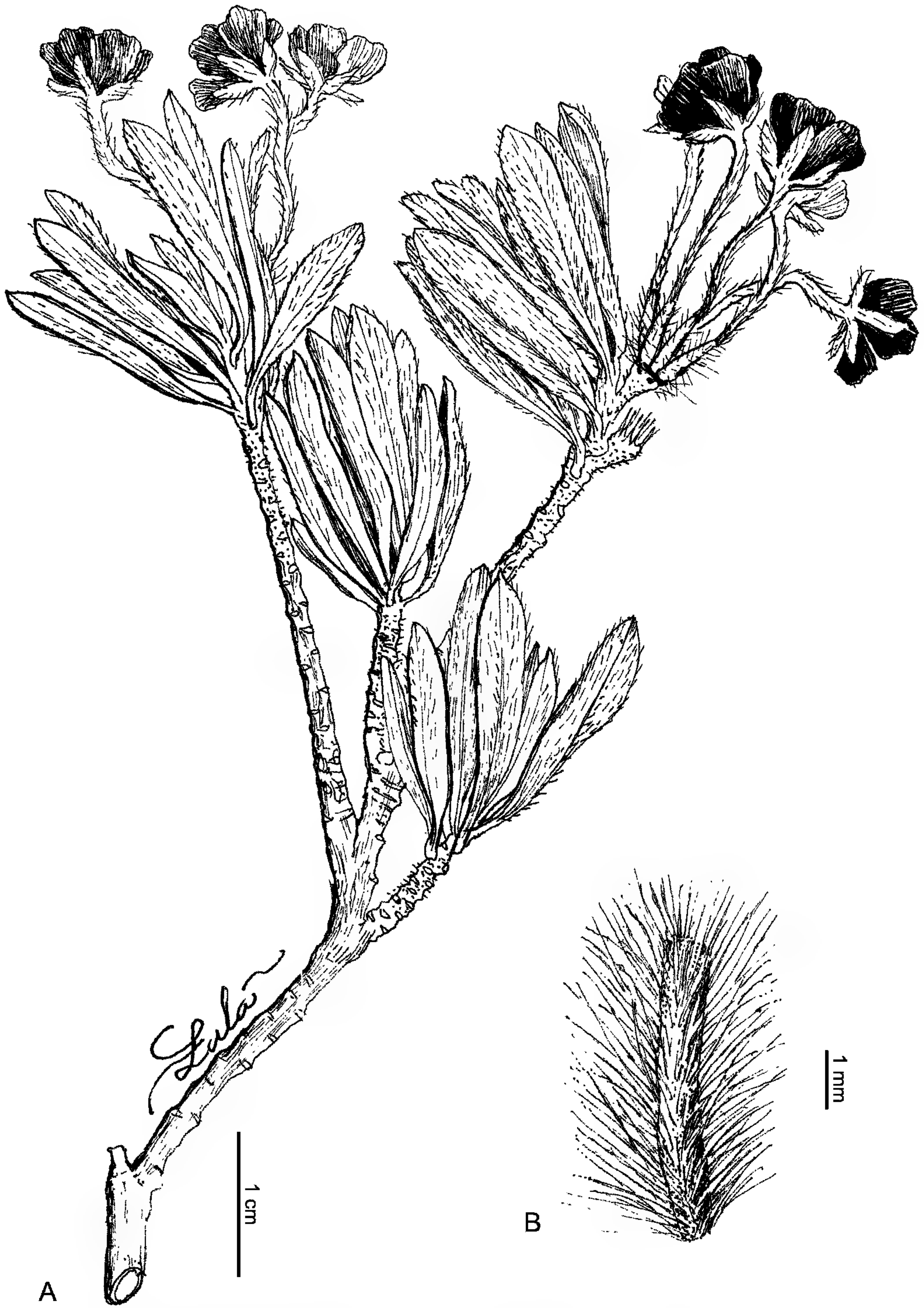

Figure 8. *Gnidia hibbertioides* (S. Moore) Z. S. Rogers. —A. Habit. Note the large petaloid scales. —B. Persistent portion of hypanthium surrounding the gynoecium. Drawn from holotype, *Thompson & Forbes s.n.* (BM).

Distribution and habitat. *Gnidia hibbertioides* is endemic to Madagascar and known only from a poorly labeled type. More specific distribution or habitat information is not available.

Phenology. The type collection is in flower, but no collection date is recorded on the specimen label or in the protologue (Moore, 1920).

IUCN Red List category. *Gnidia hibbertioides* was collected in Madagascar on one occasion in the early 1800s and is represented by a single herbarium specimen with an unspecified locality. The species is assigned a provisional IUCN (2001) conservation status of Critically Endangered (CR) (B1ab + 2ab). At the present time, the species cannot be assigned to an Extinct category (EX or EW) because exhaustive surveys searching for additional individuals have not been conducted.

Discussion. *Gnidia hibbertioides* is distinguished from *G. daphnifolia* by its 1.7–1.9 cm long hypanthium (vs. rarely to 1.5 cm long) with a 5–7 mm long persistent portion (vs. to 4 mm long) and by its large (4.6–6 × 3.8–4.7 mm) petaloid scales, which surpass the calyx lobes. The petaloid scales of *G. hibbertioides* (Fig. 8A) are generally three to four times larger than the scales of most other species of Malagasy *Gnidia*, and may prove to be the largest in the genus. Another distinctive feature of the scales is the irregularly lacerate or sinuate apical margin. Other Malagasy species have petaloid scales with entire margins that are rounded, emarginate, or lobed at the apex.

Typification. *Gnidia hibbertioides* was based on a scantily labeled sheet deposited at BM. “Madagascar” is the only locality information mentioned on the original material and cited in the protologue (Moore, 1920: 189). In unidentified handwriting on the herbarium sheet, the names of the collectors were written as “Vaughn, Thompson & Forbes.” This information is possibly a distortion of the names of two men known to have collected in Madagascar, John Vaughn Thompson and John Forbes (Dorr, 1997: 485). However, it is impossible for both men to have collected the original material jointly, because Thompson visited the island in 1814 and Forbes did not arrive until 1822 (Dorr, 1997). Nevertheless, as the only extant material of the name, this particular sheet must be considered the holotype.

9. *Gnidia humbertii* (Leandri) Z. S. Rogers, comb. nov. Basionym: *Lasiosiphon humbertii* Leandri, Bull. Soc. Bot. France 76: 1039. 1929 [1930]. TYPE: Madagascar. Fianarantsoa: Isalo, mouth of Sakamarekely & Sambalinieto rivers, 500–1000 m, 19 Oct. 1924, *H. Humbert 2844*

(lectotype, designated here, P!; isotype, G!). Figure 9.

Rounded, compact, densely ramified subshrubs to 60 cm tall; young branches densely pubescent, covered with prominent leaf scars; mature branches densely pubescent, ± exfoliating. **Leaves** alternate, spirally arranged, closely spaced, rarely with internodes to 1.5 mm, persistent only at the tips of branches; young leaves adaxially appressed against stems; petioles 0–0.3 mm, densely pubescent; blades elliptic, slightly obovate, or linear, 7–17.1 × 1.9–3 mm, l:w ratios ca. 4–8:1, silver-green, both surfaces obscured by a dense sericeous-tomentose indument of 0.2–0.3(–0.5) mm trichomes, apex acute or short-acuminate, base cuneate or attenuate; midrib obscured by indument adaxially, obscured or nearly so abaxially; venation obscured on both surfaces. **Inflorescences** terminal, erect, involucrate, (6- to)8- to 15-flowered, sessile or subsessile; peduncles to 1.5 mm, densely pubescent; involucre bracts 5, broadly ovate, 6–9 × 2–4 mm, l:w ratios ca. 2:1, erect, persistent, densely pubescent adaxially, densely pubescent on upper half abaxially, lower half sparsely pubescent or glabrescent, apex obtuse or rounded, base rounded-truncate; midrib inconspicuous adaxially, inconspicuous or slightly raised abaxially; nervation inconspicuous on both surfaces. **Flowers** 5-merous, yellow, sessile or subsessile; pedicels to 0.2 mm, densely covered with ca. 0.5(–1) mm trichomes; hypanthium 10–15 mm, articulate, coriaceous; caducous portion densely pubescent externally, trichomes 0.5–1 mm, glabrous internally; persistent portion 2–3 mm, obscured by 3–4.5 mm trichomes, glabrous internally; calyx lobes 5, spreading, broadly obovate or elliptic, 2–4.5 × 1.7–2.5 mm, glabrous adaxially, densely pubescent abaxially, apex emarginate or rounded; petaloid scales absent or 5; scales when present narrowly to broadly ovate or elliptic-linear, to 1.2 × 0.4 mm, membranous, glabrous, apex rounded; stamens 10, upper whorl of anthers ca. 1/2 exerted, lower whorl 1–4 mm below upper whorl; anthers oblong, 1–1.5 × 0.2–0.4 mm, subsessile; subgynoecial disk cupuliform, 0.3–0.5 mm tall, glabrous, membranous, apex smooth or irregularly lobed; ovary ovoid-ellipsoid, ca. 1.4 × 0.5 mm, stipitate (stipe 0.2–0.3 mm), lower half glabrous or sparsely pubescent, apex usually densely pubescent, trichomes to 1 mm; style 3.8–7 mm, glabrous or with a few trichomes on lower half; stigma near mouth or at height of lower whorl of anthers. **Fruits** ellipsoid, 2.8–3.2 × 1–1.2 mm, mostly glabrous, glabrescent or only densely pubescent near the apex.

Distribution and habitat. *Gnidia humbertii* is restricted to the subarid bioclimatic zone in southern

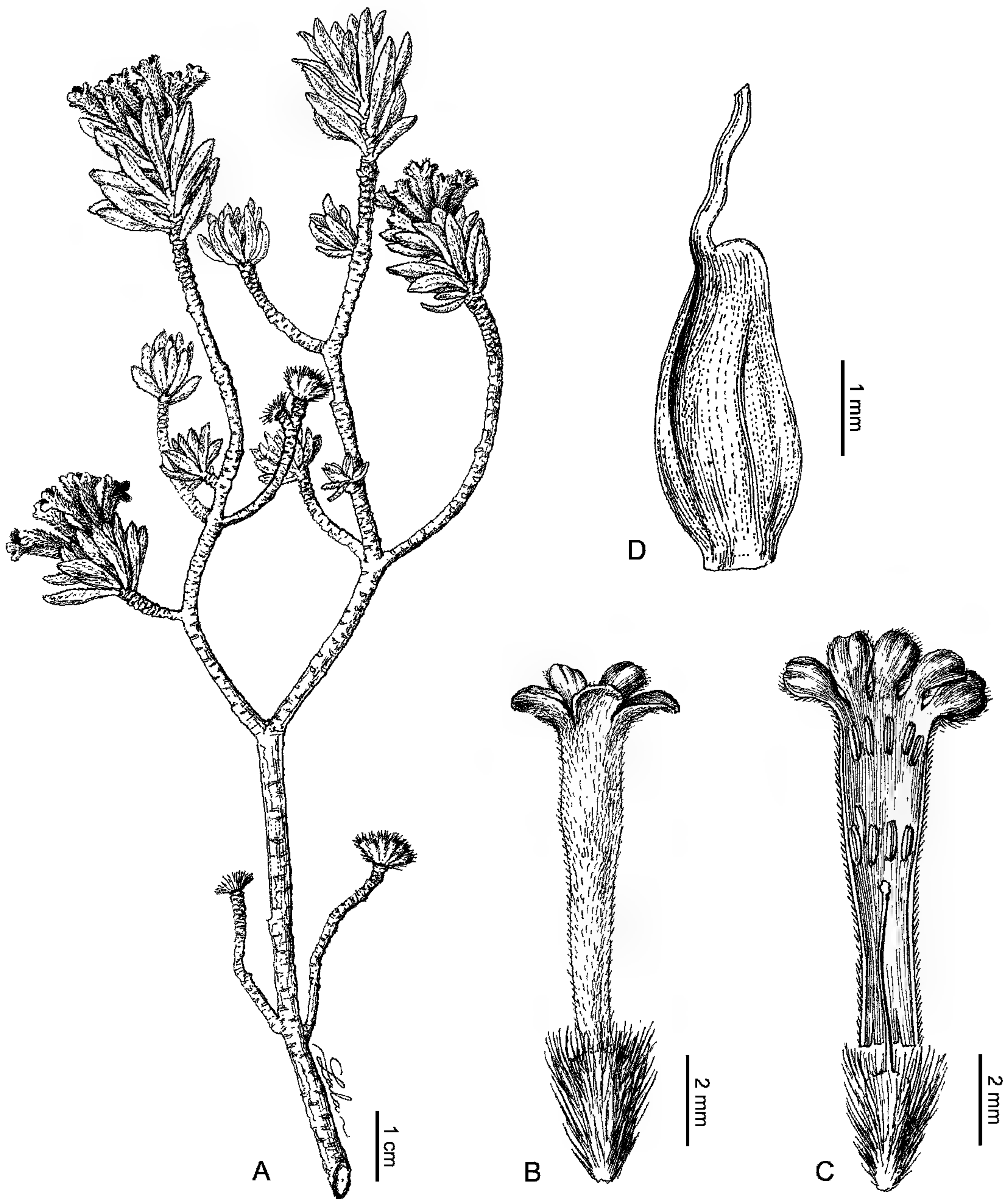

Figure 9. *Gnidia humbertii* (Leandri) Z. S. Rogers. —A. Habit. —B, C. Flower. —D. Fruit. Habit and fruit drawn from Peltier & Peltier 2469 (TAN). Flower drawn from Rogers & Rakotonasolo 399 (MO).

and southwestern Madagascar (Fig. 17). Populations occur from the Mahafaly Plateau and Isalo to Cap Sainte Marie and as far west as La Table (a mesa-like mountain on the west coast near Toliara). The species grows in open sunlit areas on sand, sandstone, and calcareous limestone (Rogers, pers. obs.).

Phenology. The species flowers and fruits year round.

IUCN Red List category. *Gnidia humbertii* has been recorded in two formally protected areas (Cap Sainte Marie, Isalo). Several large populations, obviously resistant to periodic burning, were observed at Isalo in 2004 and again in 2006. The species is assigned a preliminary IUCN (2001) status of Least Concern (LC).

Discussion. *Gnidia humbertii* is the only Malagasy species with a rounded, compact, densely ramified,

subshrub habit. The leaves of *G. humbertii* and *G. ambondrombensis* are covered on both surfaces by a dense sericeous indument, but the pubescence of the former is composed of much shorter trichomes (trichomes 0.2–0.5 mm vs. 1–1.5 mm long).

Typification. Two collections were cited in the protologue of *Lasiosiphon humbertii* (Leandri, 1930a): *Douillot [Douliot] s.n.* and *Humbert 2844*. Both collections are annotated by Leandri and match the protologue description. The P sheet of *Humbert 2844* is in better physical condition and is thus selected as the lectotype.

Selected specimens examined. MADAGASCAR. **Fianarantsoa:** Isalo Natl. Park, 2–3 km N of Natl. Rte. #7, *Rogers & Rakotonasolo 399* (BM, BR, G, K, MO [2], P, TAN, TEF, US). **Toliara:** La Table, near Tuléar, 15 Feb. 1913, *Afzelius s.n.* (P); Mahafaly Plateau, Menarandra basin, *Perrier de la Bâthie 8555* (K, P); Mangorovato, 1892, *Douillot [Douliot] s.n.* (P).

10. *Gnidia linearis* (Leandri) Z. S. Rogers, comb. nov.
Basionym: *Lasiosiphon linearis* Leandri, Bull. Soc. Bot. France 76: 1040. 1929 [1930]. *Lasiosiphon decaryi* Leandri var. *linearis* (Leandri) Leandri, Bull. Mus. Natl. Hist. Nat., sér. 2, 3: 154. 1931. TYPE: Madagascar. Toliara/Fianarantsoa: savanna betw. Bemketa [Bereketa] & Malio, 15 June 1923, *H. Poisson 692* (holotype, P!). Figure 10.

Lasiosiphon decaryi Leandri, Bull. Soc. Bot. France 76: 1041. 1929 [1930]. Syn. nov. TYPE: Madagascar. Toliara: Ambovombe (Amboasary), dunes, 21 May 1924, *R. Decary 2785* (lectotype, designated here, P!; isotypes, G!, TAN!).

Lasiosiphon decaryi Leandri var. *erectus* Leandri, Bull. Soc. Bot. France 76: 1041. 1929 [1930]. Syn. nov. *Lasiosiphon erectus* (Leandri) Leandri, Notul. Syst. (Paris) 13: 50. 1947. TYPE: Madagascar. Antananarivo: Tananarive, May 1916, *E. Waterlot s.n.* (lectotype, designated here, P 00373449!).

Lasiosiphon decaryi Leandri var. *littoralis* Leandri, Notul. Syst. (Paris) 13: 49. 1947. Syn. nov. TYPE: Madagascar. Toliara: betw. Tuléar & Manombo, May 1910, *Perrier de la Bâthie 8553* (lectotype, designated here, P 00373453!).

Lasiosiphon decaryi Leandri var. *tenerifolia* Leandri, Notul. Syst. (Paris) 13: 48. 1947. Syn. nov. TYPE: Madagascar. Toliara: Ambovombe distr., Antanimora, 6 Aug. 1924, *R. Decary 2971* (lectotype, designated here, P 00373439!; isotypes, BM!, K!, TAN!).

Shrubs to 3 m tall; young branches glabrescent to pubescent; mature branches usually lacking lenticels. **Leaves** alternate, subsessile or short petiolate; petioles to 2 mm, glabrescent to pubescent; blades linear, narrowly elliptic-oblong or obovate, 6–50 × 1.5–9 mm, l:w ratios ca. 3–14:1, both surfaces glabrescent to densely tomentose-strigose (indument gradually becoming denser moving from SE to SW populations), apex cuspidate or apiculate, base long-attenuate or cuneate; midrib inconspicuous or raised

on both surfaces, glabrescent; venation visible in larger leaves, otherwise usually inconspicuous. **Inflorescences** axillary or terminal, erect, involucre, (9- to)12- to 18-flowered, pedunculate; peduncles 5–50 mm, glabrescent to sparsely pubescent, rarely moderately pubescent; involucre bracts 5, suborbicular or broadly ovate, 5–8 × 3.8–5.1 mm, l:w ratios 1–1.5(–2):1, often caducous, chartaceous or coriaceous, both surfaces glabrescent to moderately pubescent (southwestern coastal populations), apex apiculate (apicule 1–2 mm) with a strongly decurved tip, short-acuminate, or acute, base rounded-truncate; midrib nearly inconspicuous on both surfaces, more pronounced near apex abaxially; nervation absent or represented by 1 to 5 longitudinal veins. **Flowers** 5-merous, yellow or orange, rarely red; pedicels ca. 0.5 mm, densely pubescent, trichomes 3–4 mm; hypanthium 7.1–15 mm, articulate, semimembranous to ± coriaceous, densely pubescent externally, glabrous internally; caducous portion externally covered with ca. 0.5 mm trichomes; persistent portion 3–4.5 mm, externally covered with (1–)3–5 mm trichomes; calyx lobes 5, broadly oblong-elliptic, 2–2.5 × 0.9–1.5 mm, membranous, spreading, glabrous adaxially, densely pubescent abaxially, apex emarginate or rounded; petaloid scales 5, yellow, suborbicular or obovate, 0.9–3.7 × 0.5–1.5 mm, membranous, glabrous, spreading, apex most often emarginate, sometimes rounded, truncate, or with 3 to 5 irregularly rounded lobes; stamens 10, upper whorl of anthers ca. 1/2 to 3/4 exerted, lower whorl 0.5–1 mm below upper whorl; anthers elliptic, 0.8–1 × ca. 0.3 mm, subsessile; subgynoecial disk cupuliform, 0.1–0.3 mm tall, glabrous, fleshy, apex smooth or irregularly lobed; ovary ellipsoid, 1.2–1.4 × 0.6–0.7 mm, stipitate (stipe to 0.3 mm), glabrous; style 5.2–9 mm, glabrous; stigma 0–2 mm below lower whorl of anthers, or rarely exerted by 1 mm. **Fruits** ellipsoid, 3.1–3.4 × 1.1–1.4 mm, glabrous.

Distribution and habitat. *Gnidia linearis* is almost entirely restricted to the subarid bioclimatic zone of southwest Madagascar (Toliara Province) from 0–1000 m elevation (Fig. 16). The disjunct population at Bemaraha extends the distribution by ca. 200 km to the north of other populations, and into the island's dry bioclimatic zone. Several other collections along the central plateau in the humid bioclimatic zone (1200–1400 m elevation) may have been made from cultivated plants or plants that escaped cultivation, and are denoted using a different marker in the distribution map.

Phenology. The species flowers and fruits year round.

Vernacular names. Hafodramena (*Boiteau 3097*; *Decary s.n.* [30 Aug. 1917]; *Humbert 20259*);

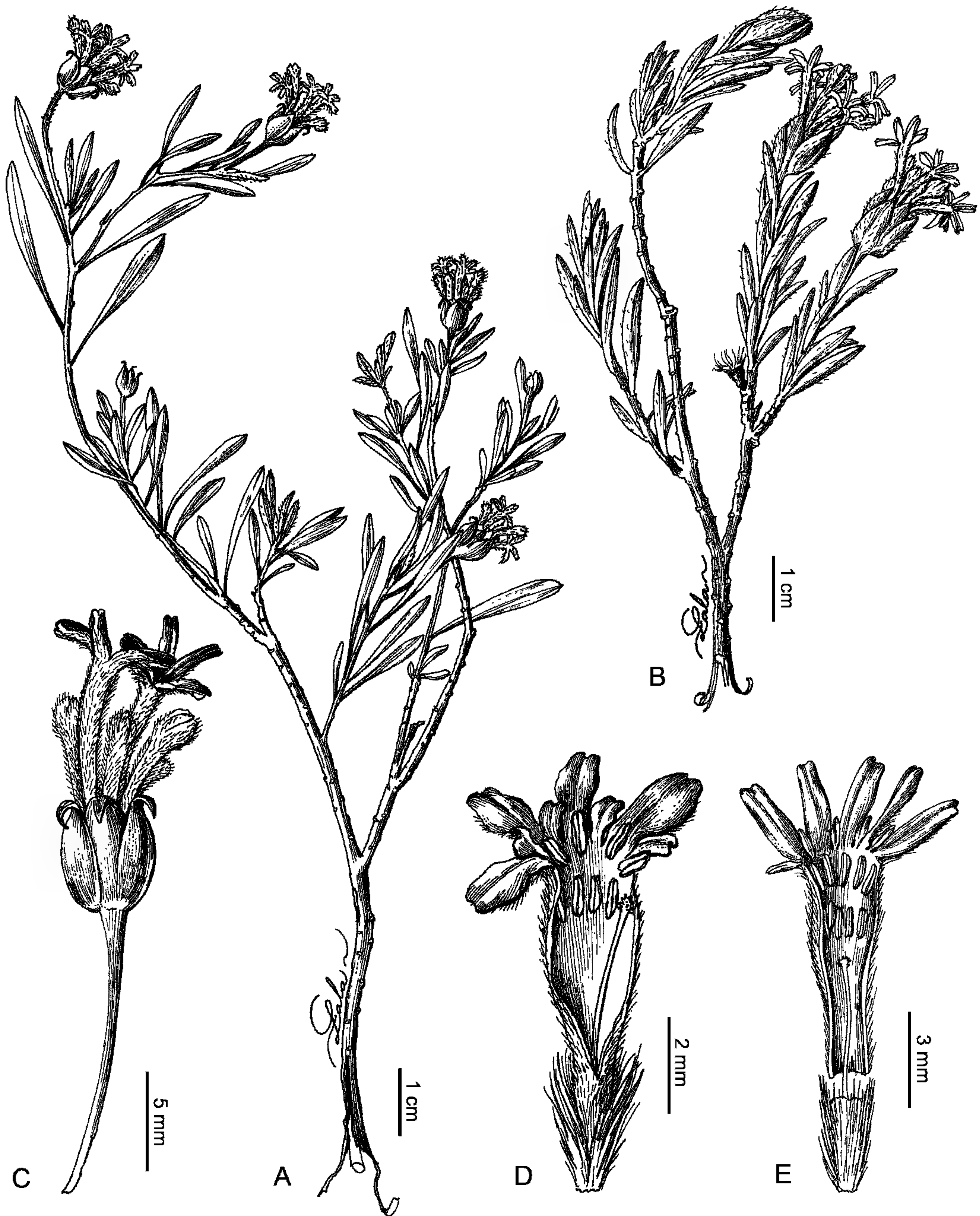

Figure 10. *Gnidia linearis* (Leandri) Z. S. Rogers. —A, B. Habits. Note variation in indument, peduncle length, and apex of involucre. —C. Inflorescence. —D, E. Flower dissections. One sepal, one petaloid scale, and one anther removed from part D. Habits drawn from *Rogers & Rakotonasolo 523* (part A, MO) and *Rogers & Rakotonasolo 419* (part B, MO). Inflorescence drawn from *Rogers & Rakotonasolo 523* (part C, MO). Flowers drawn from *Rogers & Rakotonasolo 523* (part D, MO) and *Rogers & Rakotonasolo 419* (part E, MO).

hafotra mena (*Cours 5275*); roinisa (*Réserves Naturelles [Rakotoniana] 2777*; *Réserves Naturelles [Ravelonahary] 4285*; *Rogers & Rakotonasolo 524*).

IUCN Red List category. Naturally occurring populations of *Gnidia linearis* are widespread in southwest Madagascar and have been recorded inside several protected areas (Andohahela, Isalo, Lac

Tsimanampetsotsa). The species is also cultivated in central Madagascar (Rogers, pers. obs.). *Gnidia linearis* is assigned to the conservation category of Least Concern (LC) according to IUCN (2001) criteria.

Discussion. Leandri (1930a) used two collections (*Waterlot s.n.* [June 1915] and *Waterlot s.n.* [May 1916]), both noted to be from Antananarivo, Madagascar's capital, in the description of *Lasiosiphon decaryi* var. *erectus*. Later, Leandri (1947, 1950) decided to treat the taxon at the species rank as *L. erectus*, distinguishing it from what he considered to be related species (*L. dumetorum* and *L. multifolia*, both treated here as synonyms of *Gnidia daphnifolia*) by having inflorescences of ca. 15, rather than seven to 10 flowers. Flower number can be extremely variable in many species of *Gnidia* with involucrate inflorescences, and Leandri's distinction breaks down once additional material is consulted. Nevertheless, the two *Waterlot* collections, along with several other collections from Madagascar's central plateau, differ somewhat from other populations of *G. linearis* by having more fleshy leaves and glaucous bracts when dry. The differences observed in the high plateau populations are possibly caused by their substantial geographic disjunction and from variation due to diverse biophysical parameters, e.g., 1200–1400 m elevations in the subhumid bioclimatic zone versus up to 1000 m elevation in the dry and subarid bioclimatic zone. It is also plausible that the high plateau specimens could represent cultivated plants of *G. linearis* that hybridized with another high plateau species, such as *G. perrieri*. Plants of *G. linearis* continue to be brought from southwest Madagascar to paper factories operating in several cities on the central plateau (e.g., Antananarivo, Ambositra, Fianarantsoa, Ambalavao), and cultivated plants of *G. linearis* (e.g., Rogers *et al.* 734, not mapped) were found growing at a factory in the town of Ambalavao as recently as 2008 (Rogers, pers. obs.). Despite several attempts, the naturally occurring populations on the high plateau have not been located, and additional collections and information from the area are needed to better understand the observed variation.

In the *Flore de Madagascar et des Comores*, Leandri (1950) recognized *Gnidia linearis* as a variety of the name *L. decaryi*, along with two other varieties (*L. decaryi* var. *littoralis* and *L. decaryi* var. *tenerifolia*). His varieties were distinguished by differences in leaf size and shape (e.g., leaves broader and larger in variety *littoralis*; leaves longer, but not broader in variety *tenerifolia*), flower length (10–12 mm in variety *decaryi* vs. 8–10 mm in the other two), bract morphology (e.g., apex strongly decurved in variety *littoralis*), and petaloid scales (narrower in variety

linearis). With additional material, Leandri's distinguishing characters exhibit continuous, overlapping variation. No other differences have been found to justify the recognition of Leandri's varieties.

Lasiosiphon linearis and *L. decaryi* were validly published simultaneously (Leandri, 1930a: 1040–1041), the former name being most recently recognized by Leandri (1950) in the *Flore de Madagascar et des Comores* as a variety of *L. decaryi*. Both names are considered synonymous here, and if the *decaryi* epithet were transferred into *Gnidia* the resulting combination would cause unnecessary confusion with the nomenclaturally similar, but taxonomically different, *G. decaryana*. Therefore, Leandri's less familiar *linearis* epithet is adopted to form the new combination.

The more broadly circumscribed *Gnidia linearis* is distinguished from *G. perrieri* by the young stems drying green, brown, or black (vs. red-purple or orange-red), the less fleshy and membranous leaves, the bracts that are usually apiculate and strongly decurved at the tips (vs. usually long-acuminate or acute and with erect tips), narrower leaves, longer peduncles, and the longer hypanthium trichomes ([1–] 3–5 mm vs. 0.3–0.5[–0.7] mm long).

Typification. Five collections were cited in the protologue of *Lasiosiphon decaryi* (Leandri, 1930a): *Decary s.n.* (P), *Decary* 2759 (P), 2785 (G, P, TAN), 3183 (MO, P, TAN, US), 3741 (P [2]). All examined syntypes are annotated in Leandri's handwriting and correspond closely to the description. The P sheet of *Decary* 2785 is in particularly good condition and is chosen as the lectotype.

Two collections were cited in the protologue of *Lasiosiphon decaryi* var. *erectus* (Leandri, 1930a): *Waterlot s.n.* (June 1915) and *Waterlot s.n.* (May 1916). One sheet of each collection has been located at P. The sheet dated May 1916 (P 00373449) is in better physical condition and is chosen as the lectotype.

Nine collections were cited in the protologue of *Lasiosiphon decaryi* var. *littoralis* (Leandri, 1947): *A. Grandidier s.n.* (Nov. 1868–Jan. 1869) (P), *Humbert* 2489 (G, P, TAN), *Humbert & Swingle* 5170 (P), 5294 (G, GH [2], MO, P, US, WAG), 5294bis (P), 5414bis (P), *Lam & Meeuse* 5439 (P, WAG), *Perrier de la Bâthie* 8553 (P), 12807 (K, P [2]). The Paris sheets of all nine syntypes bear Leandri's own handwritten annotations. *Perrier de la Bâthie* 8553 (P) has bracts and leaves most closely matching the description and is designated as the lectotype.

Five collections were cited in the protologue of *Lasiosiphon decaryi* var. *tenerifolia* (Leandri, 1947): *Decary* 2971 (BM, P, TAN), 3183 (MO, P, TAN, US),

8341 (P), 8966 (MO, P), Geay 6328 (P). Decary 2971 closely matches the protologue and P 00373439 is chosen as the lectotype.

Selected specimens examined. MADAGASCAR. **Antananarivo:** Antananarivo [possibly cultivated], June 1915, *Waterlot s.n.* (P); Antsahadity [possibly cultivated], *D'Alleizette 769M* (P). **Fianarantsoa:** Anjoma [possibly cultivated], Ambositra distr., Tapia forest, *Peltier 2181* (P); Horombe Plateau, *Jacquemin 1129* (P); Isalo Natl. Park, 2–3 km N of Natl. Rte. #7, *Rogers & Rakotonasolo 419* (K, MO, P, TAN); Itremo [possibly cultivated], *Perrier de la Bâthie 12471* (P). **Mahajanga:** Bemaraha Plateau, *Hb. Jard. Bot. Tananarive 6151* (P). **Toliara:** Amboasary, *Decary 3183* (MO, P, TAN, US); Ambondro–Tsihombe rd., *Croat 31647* (MO, P, TAN, WAG [2]); Ambovombe, *Decary 8966* (MO, P), 8341 (P); Ampanihy, *Humbert & Swingle 5527* (P [2]); Ampanihy to Androka rte., 16 km SW of Ampanihy, *Labat et al. 2073* (K, MO); Andohahela (Parcel #2), path from Tsimelahy W to Vohimainty, *Birkinshaw et al. 435* (GRA, MO, P, TAN); Andohahela (Parcel #3), *Eboroke 940* (GRA, MO, P, TAN); Andrevo, 35 km N of Toliara along coast rd., *Schatz et al. 1744* (K, MO, P, TAN); Androka, Ampanihy on the Linta, on Etrobeke, *Allorge 2298* (P); Androka, 38 km SW of Ampanihy, on rd. to Androka, *Phillipson et al. 3447* (G, K, MO, TAN, WAG); Ankalitany, 95 W of Fort-Dauphin on Natl. Rte. #13, *Miller & Randrianasolo 6180* (K, MO, P, PRE, TAN); Ankarobato (Tuléar), *Peltier & Montagnac 3194* (P, TAN); Ankilizato, Morondava basin, *Perrier de la Bâthie 8539* (P [2]); Antanimora, forest station near Antanimora, *Service Forestier (Capuron) 341* (P, TEF); Antanimora–Ambovombe rd., 54 km NW of Ambovombe, *Dorr et al. 3964* (K, MO, TAN, US, WAG); Antreaky, 15 km ENE of Beloha, *Fosberg 52485* (MO); Beheloka village, near beach, *Rogers & Rakotonasolo 523* (BM, G, K, MO [2], P, TAN); Beloha, on rd. S to Tranovaho, near Barabay, *Phillipson & Milijaona 3625* (G, K, MO, TAN, WAG); Berenty, *O'Connor 112* (K); Beza-Esiva, middle Mandrare basin, *Descoings 2744* (MO, TAN); Fiherenana Valley, *Humbert & Swingle 5097* (P); Ifotaka, *Lam & Meeuse 5439* (P, WAG); Ifaty, 5 km N of Town, *Rogers et al. 872* (B, MO, P, TAN); Imanombo, around Antanimora (Androy), 30–35 km N of Ambia, *Humbert & Capuron 28846* (MO, P); Italy, 30 km SW of Fort-Dauphin, *Randrianasolo et al. 143* (MO); Itampolo, *Phillipson et al. 3742* (G [2], K, MO, TAN, WAG); Kotriha, Manambolo Valley, Mandrare basin, around Isomono, Mtns. Kotriha & Isomonobe, *Humbert 12812* (G, MO, P); La Table, *Dequaire (Hb. St. Agric. Alaotra) 27333* (MO, P, TAN); Lac Tsimanampetsotsa, *Rogers & Rakotonasolo 544* (MO, P, TAN, TEF); Mangoky, on Malio River, *Perrier de la Bâthie 8543* (P); Ranopiso, 1 km E of the town, *Rogers et al. 911* (BM, BR, CAS, G, GH, K, MO, P, TAN, US, WAG); Tsimanampetsotsa, Lac Manampetsotsa, delta of Linta, sand near Beheloka, *Humbert & Swingle 5294* (G, GH [2], MO, P, US, WAG), 5294bis (P), near Itampolo, *Humbert & Swingle 5414bis* (P); Tsvionoakely, 18–30 km N of Tuléar, *Miller & Randrianasolo 6104* (K [2], MO, P, PRE, TAN); Tuléar, Nov. 1868–Jan. 1869, *A. Grandidier s.n.* (P); same locality, *Humbert & Perrier de la Bâthie 2489* (G, P, TAN); Tuléar, near ocean, *Perrier de la Bâthie 12807* (K, P [2]); Tuléar, delta of Fiherenana, *Humbert & Swingle 5170* (P); Tuléar–Manombo, *Perrier de la Bâthie 8553* (P).

11. *Gnidia neglecta* Z. S. Rogers, sp. nov. TYPE:
Madagascar. Toamasina: Andevorante [Andevor-

anto], Moramanga, sandy plain, 3 Oct. 1912, *K. Afzelius s.n.* (holotype, P!). Figure 11.

*Species nova quae a *Gnidia decaryana* Leandri lamina foliari late ovata basi cordata (haud obovata vel suborbiculari basi cuneata usque attentuata) reti venularum dense discolori fuscato (haud plus minusve inconspicuo concolori), inflorescentiis pedunculatis (haud sessilibus vel subsessilibus) et hypanthio glabro (haud extus dense pubescenti) differt.*

Shrub; young branches glabrous, flattened (especially near internodes); branches not lenticellate, covered with prominent leaf scars. **Leaves** opposite, presumably decussate, pairs rarely subopposite; petioles 0.6–1 mm, glabrescent; blades broadly ovate, 8–17 × 4–12 mm, l:w ratios ca. 1.3–2:1, glabrous, abaxial surface slightly glaucous, apex rounded or obtuse, tip apiculate or rarely emarginate, margin with a distinct vein, base cordate; midrib depressed adaxially, raised abaxially, glabrescent and darker than blade on both surfaces; venation darker than blade, glabrous, raised on both surfaces, more pronounced abaxially; secondary veins forming a brochidodromous loop near the margin; fine venation uniformly reticulate, densely congested, more pronounced abaxially, smallest areolae ca. 0.2 × 0.2 mm. **Inflorescences** terminal, capitate, 2- to 4-flowered; peduncles to 2.5 cm, flattened, glabrous, subtended at base by leaves ca. 1/2 the size of next lower leaf pair (i.e., modified inflorescence bracts absent). **Flowers** 4-merous, sessile; hypanthium 7.8–8.2 mm, articulate, ± membranous, glabrous; persistent portion 2.8–3.4 mm; calyx lobes 4, broadly elliptic or orbicular, 2.1–2.5 × 1.5–2 mm, glabrous, apex rounded, obtuse, or less often emarginate; petaloid scales absent; stamens 8, upper whorl of anthers 1/4 to 1/2 exerted, lower whorl 0.7–1 mm below upper whorl; anthers elliptic, 0.7–0.8 × ca. 0.25 mm, subsessile; subgynoecial disk cupuliform, to 0.2 mm tall, glabrous, membranous, apex irregularly lobed; ovary ellipsoid, 1.1–1.2 × ca. 0.6 mm, not obviously stipitate, mostly glabrous, apex with a few 0.5(–0.8) mm trichomes; style ca. 2.7 mm, glabrous; stigma ca. 2.7 mm below lower whorl of anthers. **Fruits** not seen.

Distribution and habitat. *Gnidia neglecta* is an eastern littoral species known from a single specimen, which was collected on a sandy plain near Andevoranto and Ambila–Lemaitso in Madagascar's humid bioclimatic zone near sea level (Fig. 17).

Phenology. The species flowers in October.

IUCN Red List category. *Gnidia neglecta* was collected on one occasion in 1912. No populations were located at the type locality in February 2006. Due to the apparent rarity of the species, the period of

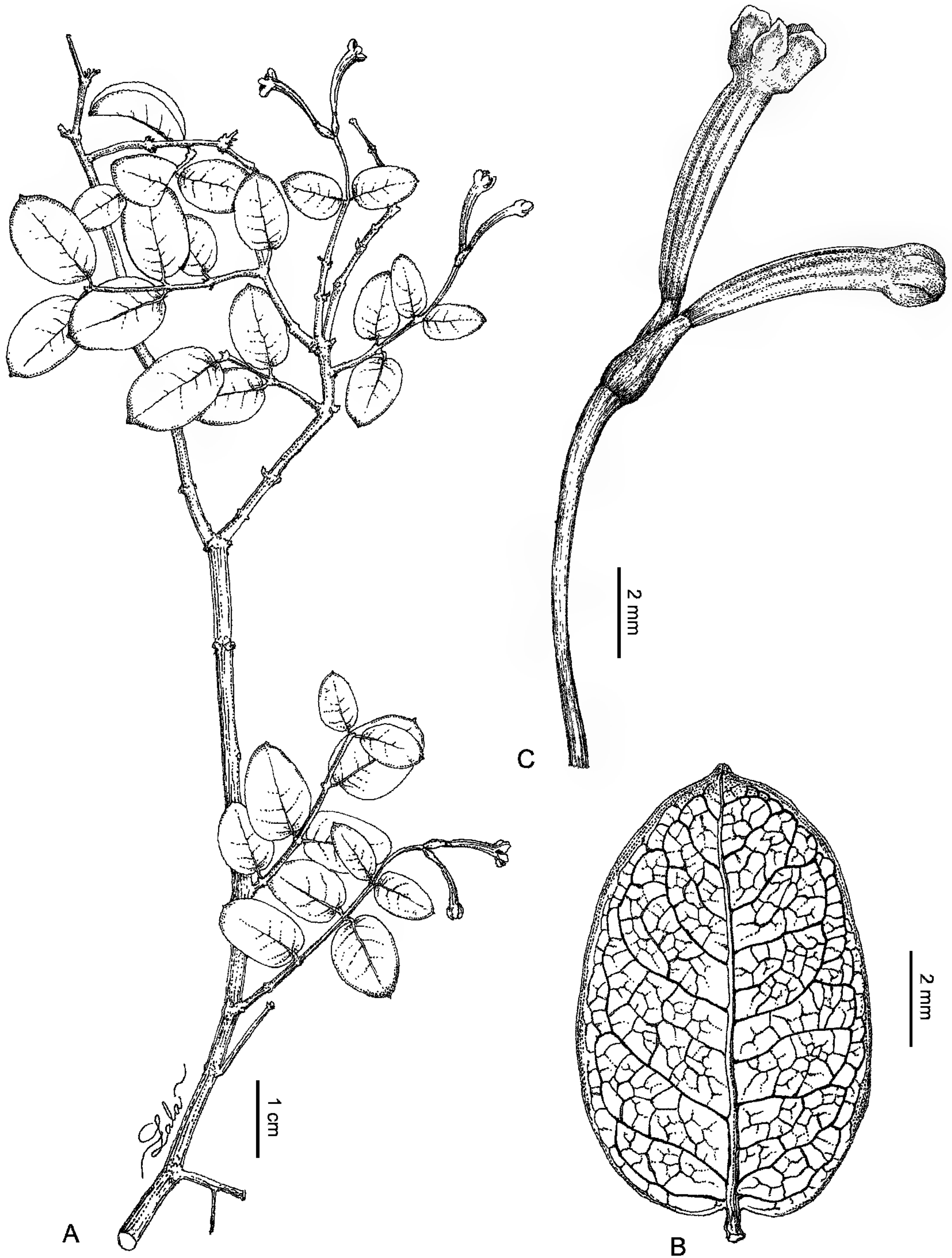

Figure 11. *Gnidia neglecta* Z. S. Rogers. —A. Habit. —B. Leaf, abaxial surface. —C. Inflorescence. Drawn from holotype, Afzelius s.n. (P).

time since it was last collected, an AAO estimated to be less than 10 km², and the highly threatened littoral forest habitat, it is prudent to assign *G. neglecta* a preliminary IUCN (2001) conservation status of Critically Endangered (CR) (Blab + 2ab).

Discussion. Vegetatively, this new taxon might be mistaken as a species of the large genus *Wikstroemia* Endl. (distinguished from *Gnidia* by the unarticulated hypanthium and a relatively well-developed subgynoecial disk), or even confused with the small, usually lianescent, genus *Synaptolepis* (tube also unarticulated). The flowers on the type of *G. neglecta* are obviously articulated and lack or possess only a minute disk up to 0.2 mm tall, features which suggest that this new taxon best fits morphologically within *Gnidia*. No species of *Wikstroemia* (nor the closely related *Daphne* L.) have been collected on Madagascar, and the island's sole species of *Synaptolepis* (*S. perrieri* Leandri) in no way resembles the new species.

Gnidia neglecta differs from *G. decaryana* by its broadly ovate leaves with cordate bases (vs. obovate to suborbicular leaves with cuneate to attenuate bases), its more numerous, subparallel or more weakly arcuate secondary veins that form a discrete brochidodromous loop (vs. fewer, concolorous, strongly arcuate secondaries lacking a distinct loop), its conspicuous, dense, dark, fine venation (vs. inconspicuous or faint, irregular fine venation), its pedunculate (vs. sessile or subsessile) inflorescences, and its completely glabrous (vs. externally densely pubescent) hypanthium.

Gnidia neglecta superficially resembles the south-east African species *G. subcordata* (sometimes treated as *Englerodaphne subcordata*), but can be distinguished by the same venation patterns that separate it from *G. decaryana*, in addition to the shorter (7.8–8.2 mm vs. 11–15 mm long), completely glabrous (vs. sparsely pubescent), cylindrical (vs. \pm funnel-shaped) hypanthium.

Etymology. The epithet *neglecta* draws attention to the fact that this distinctive new species was overlooked by botanists for almost 100 years, having been originally misidentified anonymously as *Gnidia decaryana*.

12. *Gnidia occidentalis* (Leandri) Z. S. Rogers, comb. nov. Basionym: *Lasiosiphon occidentalis* Leandri, Notul. Syst. (Paris) 13: 47. 1947. TYPE: Madagascar. Mahajanga: Kamakama forest, Ankara plateau, 14 July 1901, *H. Perrier de la Bâthie* 1276 (lectotype, designated here, P!). Figure 12.

Shrubs to 1 m tall, weakly branched; young branches densely to moderately pubescent; mature branches lacking lenticels or only sparsely lenticel-

late. **Leaves** alternate, persistent on older branchlets; petioles ca. 1(–2) mm, sparsely pubescent or glabrescent; blades narrowly elliptic or slightly obovate, 2.1–4.5(–6.2) \times 0.5–1.6 cm, l:w ratios ca. 3.5–6:1, light green when dry, both surfaces sparsely to moderately pubescent, trichomes ca. 0.5–1 mm, apex apiculate or acute, base cuneate to long-attenuate; midrib depressed adaxially, raised abaxially, lighter green than blade abaxially when dry, glabrescent to moderately pubescent on both surfaces; venation usually raised on both surfaces, more pronounced abaxially. **Inflorescences** axillary or terminal, involucre, 7- to 14-flowered; peduncles 2–20(–32) mm, densely to moderately pubescent; involucre bracts 5(6), narrowly lanceolate or elliptic-ovate, 8–15 \times 1.8–4 mm, l:w ratios 3–7:1, spreading, persistent, apex acute, base rounded-truncate, moderately to sparsely pubescent on both surfaces; midrib conspicuous adaxially, usually conspicuous in upper half abaxially; nervation faint or inconspicuous on both surfaces. **Flowers** 5-merous, red; pedicels 0.4–1.5 mm, densely covered with (1.5–)2.5–3.5 mm trichomes; hypanthium 12.5–16 mm, articulate, coriaceous; caducous portion densely pubescent externally with 0.5–1(–1.5) mm trichomes, glabrous or sparsely pubescent near articulation internally; persistent portion 3–3.5 mm, densely pubescent externally with 1–2.5 mm trichomes, glabrous internally; calyx lobes 5, broadly elliptic-oblong or obovate, 1.7–2.9 \times 1.2–1.7 mm, glabrous adaxially, densely pubescent abaxially, apex emarginate or rarely rounded; petaloid scales 5, linear or narrowly elliptic, 0.5–1 \times 0.1–0.3 mm, membranous, glabrous, apex rounded or emarginate; stamens 10, upper whorl of anthers located just below mouth, lower whorl 1–1.5 mm below upper whorl; anthers oblong, 1–1.5 \times ca. 0.3 mm, subsessile; subgynoecial disk cupuliform, 0.1–0.3 mm tall, glabrous, fleshy, apex smooth or irregularly lobed; ovary ovoid-oblong, 1.2–1.5 \times ca. 0.6 mm, sessile or shortly stipitate (stipe to ca. 0.2 mm), glabrous; style 4–7.6 mm, glabrous; stigma 0–4 mm below lower whorl of anthers. **Fruits** ovoid, 3–3.4 \times 1.3–1.6 mm, glabrous.

Distribution and habitat. *Gnidia occidentalis* is known from several collections from northwest Madagascar (Mahajanga Province) in the dry bioclimatic zone (Fig. 17). No elevation data are available on specimen labels, but the estimated range for the species is 150–400 m based on an ArcGIS digital elevation model (DEM). The species is noted on labels as occurring in forested habitats on calcareous limestone, basalt, and granite. Given what is known about the ecological preferences of other species of Malagasy *Gnidia*, it seems likely that *G. occidentalis* grows along forest edges or in open sunlit patches within scrub forest.

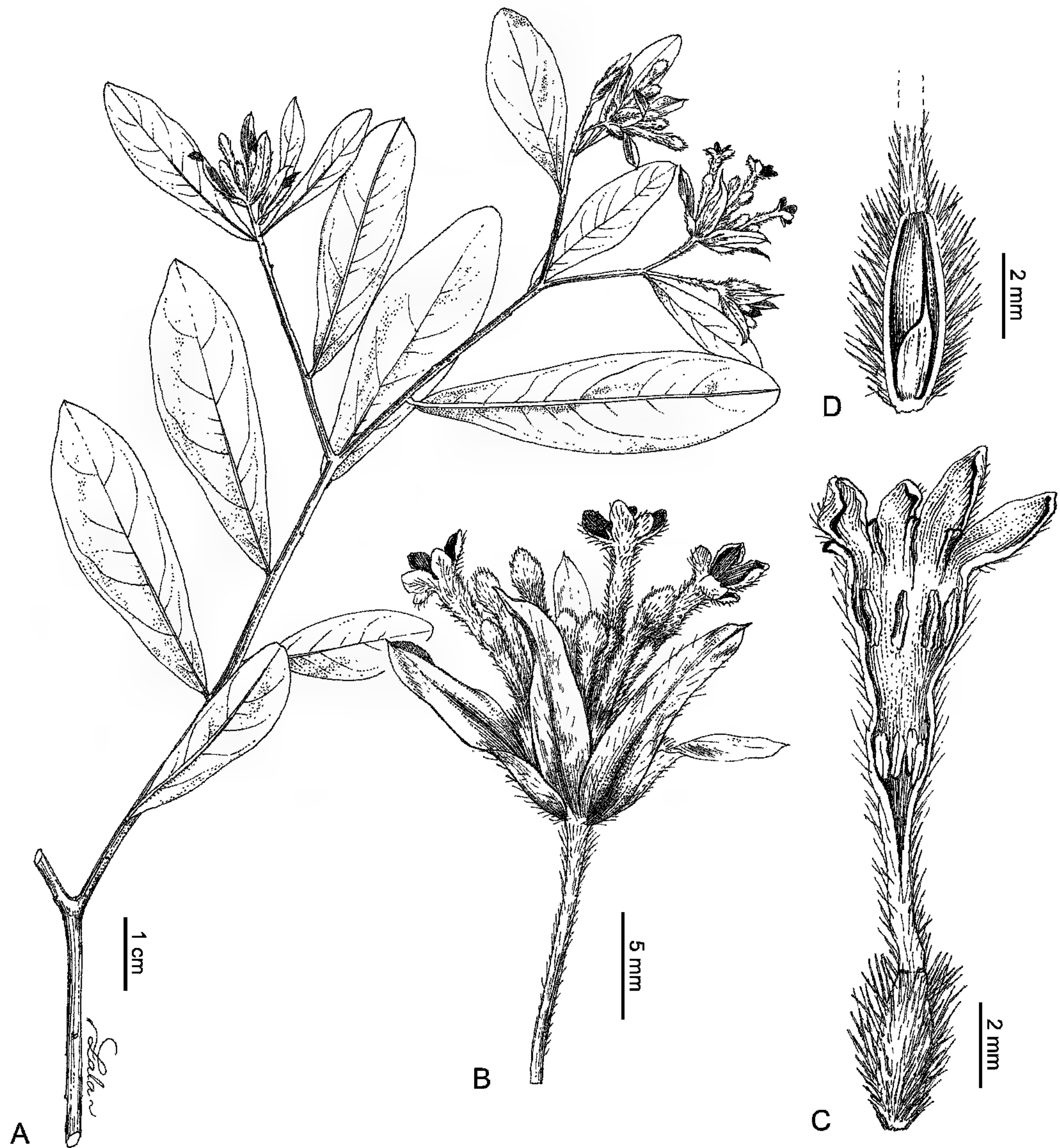

Figure 12. *Gnidia occidentalis* (Leandri) Z. S. Rogers. —A. Habit. —B. Inflorescence. —C. Flower, longitudinal section through caducous portion of hypanthium. —D. Longitudinal section through persistent portion of hypanthium. Drawn from Morat 4550 (TAN).

Phenology. The species flowers and fruits in May, October, and November.

Vernacular name. Fafitao (*Réserves Naturelles* [Rakotovao] 5393).

IUCN Red List category. *Gnidia occidentalis* has been recorded from one protected area (Namoroka). This species is provisionally assigned a conservation status of Least Concern (LC) based on IUCN (2001) criteria.

Discussion. At the time of the original description, Leandri (1947: 47–48) cited five collections of *Gnidia occidentalis*, which were informally categorized as either belonging to the normal form (*Perrier de la Bâthie* 1276), or “probablement des formes de la même espèce” (*Decary* 8181, *Perrier de la Bâthie* 998, 8549, 16324). The flowers of the species were described in the protologue as 5-merous. Strangely, Leandri (1947, 1950) failed to notice that two of his syntypes (*Decary* 8181 and *Perrier de la Bâthie* 998)

consistently have 4-merous flowers and that the leaves and bracts closely matched those of the similarly distributed species, *G. gilbertae*. Both collections without a doubt represent that species. Leandri (1947, 1950) mentioned that another one of the syntypes, *Perrier de la Bâthie 16324*, possessed certain characters of *G. daphnifolia*, and the collection is identified here as that species. The two remaining syntypes, *Perrier de la Bâthie 1276* and *Perrier de la Bâthie 8549*, differ consistently from *G. daphnifolia* and *G. gilbertae* by several characters, and thus are treated here as belonging to the recircumscribed *G. occidentalis*.

Gnidia occidentalis is distinguished from *G. daphnifolia* by its bracts drying light green, green-red, or yellow-brown with 3–7:1 l:w ratios (vs. drying black or brown at least in the lower half and with 2–4:1 l:w ratios), and its 12.5–16 mm (vs. 6.5–12[–15] mm) long hypanthia.

Compared to *Gnidia gilbertae*, *G. occidentalis* differs by its 5- (vs. 4-)merous flowers, its articulate (vs. unarticulate) hypanthium, and its narrower bracts measuring 1.8–4 mm (vs. 4–7 mm) wide.

When sterile, *Gnidia occidentalis* may be difficult to distinguish from *G. bojeriana*, but it can be recognized by its narrower spreading (vs. recurved) bracts with sparser indument.

Nomenclature and typification. The earlier invalid homonym *Gnidia occidentalis* Regel (1860) was originally published as a nomen nudum and presumably based on an Asian species of *Diarthron* Turcz. or *Stellera* L. *Gnidia occidentalis* Regel was never validated later by a description or diagnosis, making the epithet available for use in the new combination proposed here.

As mentioned above, Leandri (1947, 1950) considered *Perrier de la Bâthie 1276* to represent the most common form of *Gnidia occidentalis*, and now only two of the five collections cited in the protologue (Leandri, 1947) belong to the recircumscribed *G. occidentalis*: *Perrier de la Bâthie 1276* (P) and *8549* (P). The sheet of *Perrier de la Bâthie 1276* (P 00373473) is designated as the lectotype.

Selected specimens examined. MADAGASCAR. **Mahajanga:** Manasamody, betw. Port Bergé & Antsohihy, *Morat 4550* (P, TAN); Mt. Ambohibenga, Milanja, near Cap d'Andre, *Perrier de la Bâthie 8549* (P); Namoroka (Natural Reserve #8), Soalala, *Réserves Naturelles (Rakotovo) 5393* (P).

13. *Gnidia perrieri* (Leandri) Z. S. Rogers, comb. nov. Basionym: *Lasiosiphon perrieri* Leandri, Notul. Syst. (Paris) 13: 49. 1947. TYPE: Madagascar. Fianarantsoa: Andringitra Massif (Iratsy), valley of Riambava & Antsifotra, 2000–2500 m, 27 Nov. 1924, *H. Humbert 3827*

(lectotype, designated here, P!; isotypes, BM!, G [2]!, K!, MO!, TAN!, US!). Figure 13.

Shrubs to 1.5 m tall, weakly branched; young branches glabrous, red-purple or orange-red when dry; mature branches usually lenticellate. **Leaves** alternate, rarely subopposite, usually persistent on older branchlets, sessile or subsessile; petioles to 0.5 mm, glabrous; blades broadly elliptic or slightly obovate, 9–35 × 4–8 mm, l:w ratios ca. 2–5:1, usually drying dark green, sometimes glaucous, membranous and somewhat fleshy, both surfaces glabrous, apex apiculate, base long-attenuate or cuneate; midrib raised or plane on both surfaces, glabrous; venation discolorous, usually inconspicuous adaxially, inconspicuous or raised abaxially. **Inflorescences** axillary or terminal, involucre, 6- to 19-flowered, subsessile to short-pedunculate; peduncles 2–5(–8) mm, glabrous, drying dark; involucral bracts 5, persistent through fruiting phase, ovate, 4.9–10.8 × 2–5.4 mm (of various sizes in the same inflorescence), l:w ratios 2–3.5:1, usually dark red-purple when dry, somewhat fleshy, erect, glabrous adaxially, densely to moderately pubescent abaxially, apex acuminate, acute, less often apiculate, base rounded or rounded-truncate; midrib raised or inconspicuous on both surfaces; nervation inconspicuous or with 2(4) veins diverging longitudinally from midvein near base. **Flowers** 5-merous, yellow or orange, short-pedicellate; pedicels 0.3–0.9 mm, densely puberulent, trichomes to 0.3 mm (i.e., not reaching base of ovary); hypanthium 6–8(–9) mm, articulate, ± coriaceous, densely pubescent externally, glabrescent or pubescent in lower half internally between anthers and above articulation; caducous portion with trichomes to 0.3 mm; persistent portion 2.5–3.5 mm, trichomes 0.3–0.5(–0.7) mm; calyx lobes 5, broadly elliptic or obovate, 1.4–2.9 × (0.8–) 1.2–2.1 mm, semi-membranous, glabrous and papillate adaxially, densely pubescent abaxially, apex emarginate or rounded; petaloid scales 5, oblong-elliptic or obovate to suborbicular, 0.3–0.6 × 0.2–0.5 mm, membranous, glabrous, apex emarginate or rounded; stamens 10, upper whorl of anthers ca. 1/4 to 3/4 exerted, lower whorl 0.1–0.5 mm below upper whorl; anthers elliptic or elliptic-oblong, 0.6–0.9 × 0.2–0.3 mm, sessile; subgynoecial disk cupuliform, 0.1–0.2 mm tall, glabrous, fleshy, apex smooth or with a few irregular lobes; ovary ellipsoid, 1.1–1.5 × 0.5–0.6 mm, sessile, glabrous, sometimes with a few trichomes to 0.3 mm near apex; style 3.2–7.8 mm, portion below articulation persistent, glabrous; stigma located just below or at height of upper whorl of anthers. **Fruits** ellipsoid, 3.3–4.1 × 1.4–1.5 mm, glabrous.

Distribution and habitat. *Gnidia perrieri* is endemic to the Andringitra massif from 2000–2550 m elevations (Fig. 16). The species occurs in sunlit,

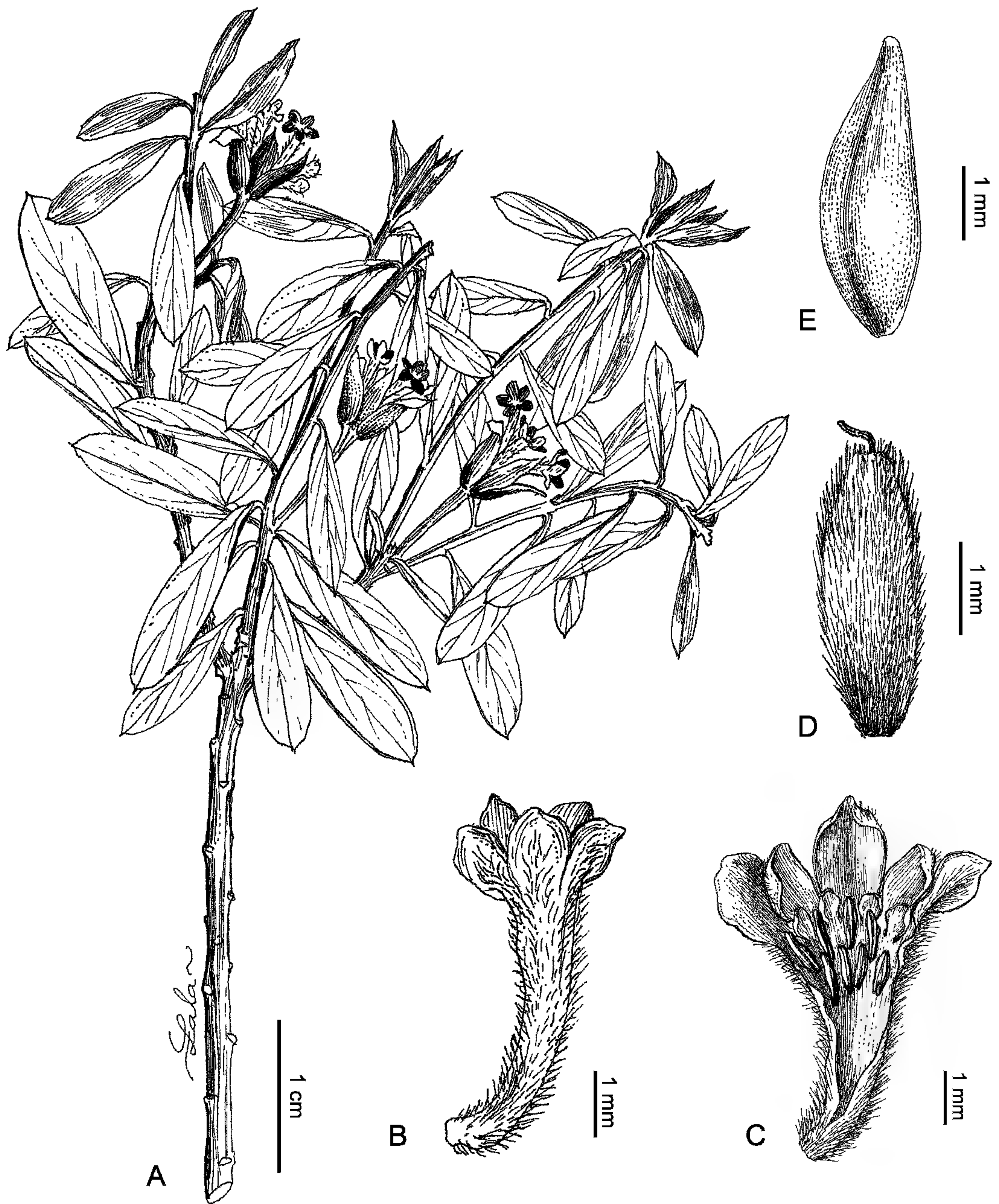

Figure 13. *Gnidia perrieri* (Leandri) Z. S. Rogers. —A. Habit. —B, C. Caducous portion of the hypanthium. —D. Persistent portion of the hypanthium surrounding the gynoecium. —E. Seed. Habit and floral parts drawn from isotype, Humbert 3827 (P). Seed drawn from Guillaumet 3550 (TAN).

ericoid scrubland and on rocky slopes in the subhumid bioclimatic zone.

Phenology. The species has been collected in flower and fruit in May, October, and November.

IUCN Red List category. *Gnidia perrieri* is endemic to one formally protected area (Andringitra). The species must be somewhat resistant to fire as it

grows in ericoid scrub along a few of the higher plateaus and peaks in the area. The species is assigned a provisional IUCN (2001) conservation assessment of Vulnerable (VU) to extinction (Blab + 2ab).

Discussion. *Gnidia perrieri* is distinguished from *G. linearis* and *G. daphnifolia*, the two most

morphologically similar Malagasy species, by its red-purple or orange-red (vs. green, brown, or black) young stems after drying, its membranous, semi-fleshy (vs. coriaceous, chartaceous, or rarely slightly fleshy) blades and bracts, its 2–5(–8) mm (vs. up to 50 mm) long peduncles, and its 0.3–0.5(–0.7) mm (vs. [1–]3–5 mm) long trichomes on the persistent portion of the hypanthium. In the dried state, collections of *G. perrieri* usually have slightly glaucous leaves, bracts, and peduncles.

Compared to continental African *Gnidia*, *G. perrieri* is most similar to *G. macropetala* Meisn. *Gnidia perrieri* differs by its completely glabrous (vs. densely pubescent) stems and leaves, its more fleshy leaves and bracts, its five (vs. eight) involucre bracts, and its shorter hypanthia (6–9 mm vs. 12–18 mm).

Typification. Four collections were cited in the protologue: *Humbert 3827* (BM, G [2], K, MO, P, TAN, US), *Perrier de la Bâthie 8554* (P), *13700* (P), *14488* (P). Each one of these was annotated in Leandri's hand, and the morphology of all four closely correspond to the description. The P sheet of *Humbert 3827* is selected as the lectotype as it is in the best physical condition and its duplicates are the most widely distributed.

Selected specimens examined. MADAGASCAR. **Fianarantsoa:** Andringitra massif, *Perrier de la Bâthie 8554* (P), *13700* (P), *14488* (P); Andringitra, Pic Bory [Boby], *Guillaumet 3550* (MO, P, TAN).

14. *Gnidia razakamalalana* Z. S. Rogers, *Adansonia*, sér. 3, 28: 156. 2006. TYPE: Madagascar. Toliara: Fivondronona Fort-Dauphin, Ivohibe Forest, 112 m, 29 Nov. 2005, R. Razakamalala, E. Ramisy & B. Mara 2670 (holotype, MO!; isotypes, K!, P!, TAN!). Figure 14.

Treelets 2 m tall, with dichotomous branching; internodes very short (ca. 1 mm long near branch tips); branches glabrous, covered by prominent leaf scars. **Leaves** alternate, spirally arranged, sessile or subsessile, persistent only at branch tips; blades ovate-lanceolate or elliptic, 4.5–8.4 × 1–1.2 cm, l:w ratios 4–7:1, adaxially glabrous, abaxially densely sericeous, apex acute, base obtuse-shortly decurrent or truncate; midrib depressed adaxially, raised abaxially; venation brochidodromous, inconspicuous or only faintly visible, more obvious abaxially; petioles 0–0.3 mm, densely sericeous. **Inflorescences** terminal, erect, 1-flowered, leaving prominent scars on older branches. **Flowers** 5-merous, reddish white, sessile or subsessile, surrounded by several

involute leaves (each at least partly appressed to the lower portion of the floral tube, the distal ones becoming smaller in size and lighter in color); hypanthium ca. 5 cm, ca. 1 mm diam. near base, ca. 3 mm diam. at mouth, articulation not seen, externally covered by dense sericeous-tomentose trichomes intermixed with longer straight trichomes, indument ± uniform along the length of the tube, glabrous internally; calyx lobes 5, spreading, lanceolate-elliptic, 1.7–2.2 cm × 3.5–5 mm, more membranous than hypanthium, papillate and sparsely tomentose-sericeous adaxially, trichomes shorter than those on the abaxial surface, indument not as dense as that on the tube abaxially, apex acute or apiculate, with a dense tuft of straight trichomes; petaloid scales 5, oblong, ovate, or subtriangular, 1.8–2.2 × 0.7–1 mm, membranous, glabrous, apex irregularly 1- to 5-lobed, with each lobe of varying length; stamens 10, upper whorl of anthers positioned just below mouth, lower whorl 2–4 mm below upper whorl; anthers oblong, ca. 3 × 0.5 mm; subgynoecial disk cupuliform, to 0.7 mm tall, glabrous, membranous, apex irregularly lobed, sinuses mostly shallow; ovary ellipsoid, ca. 2.2 × 1 mm, shortly stipitate, apex covered with a tuft of 1.5–2.3 mm trichomes, otherwise glabrous; style 1.5–1.8 cm, ± flattened, ca. 0.3 mm wide, glabrous; stigma ca. 1.5 mm below lower whorl of anthers (i.e., located near middle of tube), fusiform, ca. 4 mm long, ca. 0.5 mm wide, densely papillate. **Fruits** not seen.

Distribution and habitat. *Gnidia razakamalalana* is apparently a narrow endemic, with only one known population occurring in a subcoastal forest in southeastern Madagascar at ca. 100 m elevation (Fig. 17). The species grows on a slope among exposed granite boulders on black sandy soil (R. Razakamalala, pers. comm.).

Phenology. The species has been collected in flower in February and November.

IUCN Red List category. *Gnidia razakamalalana* is known from a single unprotected population. The AOO is estimated to be no more than 10 km² given a grid cell of the same size. Considering the restricted range of the species and unprotected habitat, the species is assigned an IUCN (2001) preliminary conservation status of Endangered (EN) (B1ab + B2ab).

Discussion. *Gnidia razakamalalana* is easily distinguished from all other Malagasy species by the ca. 5 cm long flowers arranged in 1-flowered terminal inflorescences, and the 1.7–2.2 cm × 3.5–5 mm

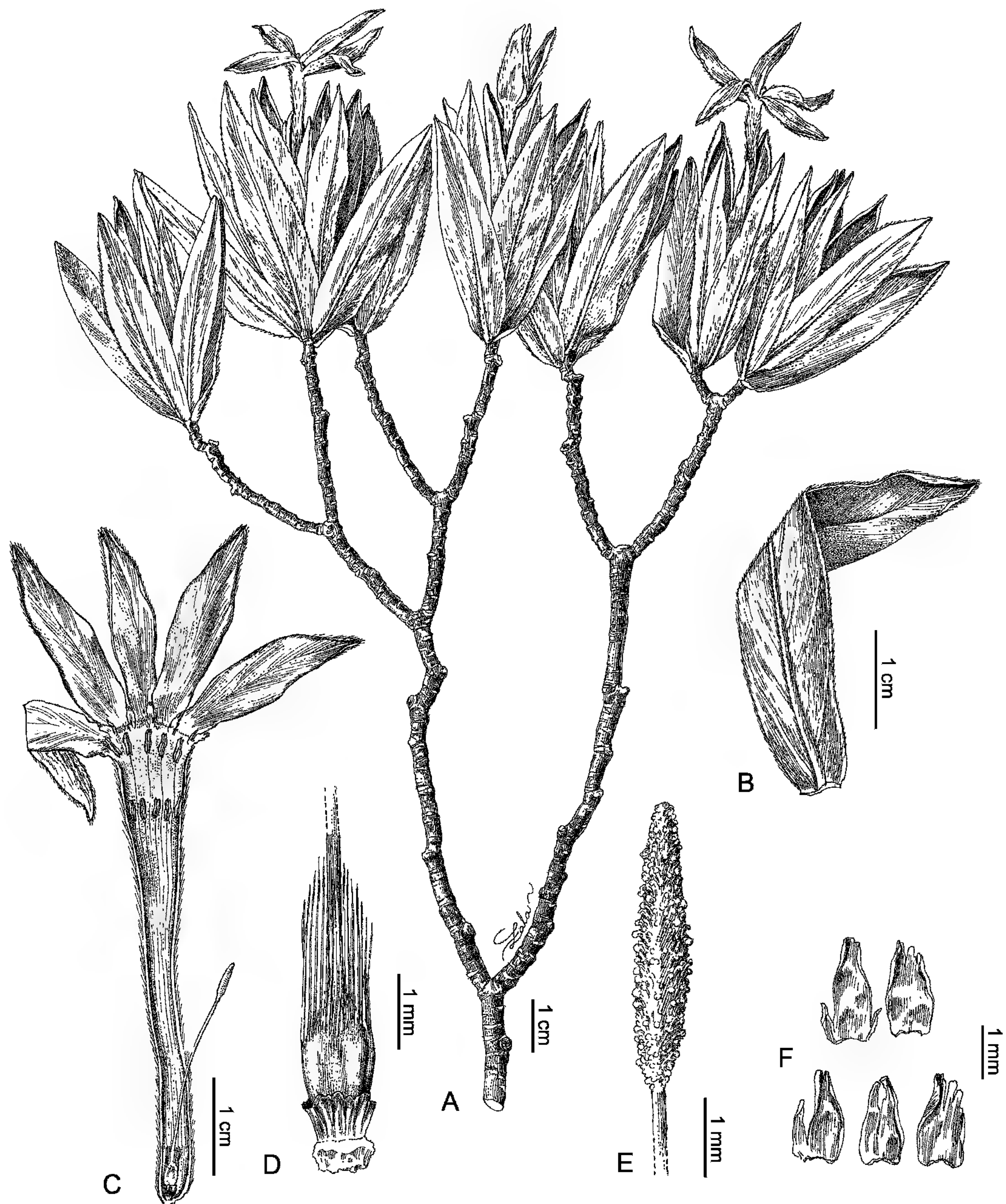

Figure 14. *Gnidia razakamalalana* Z. S. Rogers. —A. Habit. —B. Leaf. —C. Flower. —D. Gynoecium and subgynoecial disk. —E. Stigma. —F. Petaloid scales. Drawn from holotype, *Razakamalala et al.* 2670 (MO).

calyx lobes. Sterile specimens are also easy to identify because the leaves are densely sericeous abaxially and completely glabrous adaxially.

The large fusiform stigma (Fig. 14C) is unique within the Malagasy members of the genus. At present, this species is only known from flowering material and the hypanthium does not show any signs

of articulation. Presumably, the articulation develops in late anthesis, but additional collections are needed to confirm this hypothesis.

Selected specimen examined. MADAGASCAR. **Toliara:** Anosy region, Fort Dauphin, Commune Iabakoho, Quartier Antsotso, Ivohibe-Bemangidy, *Rabenantoandro et al.* 1725 (MO, P, TAN).

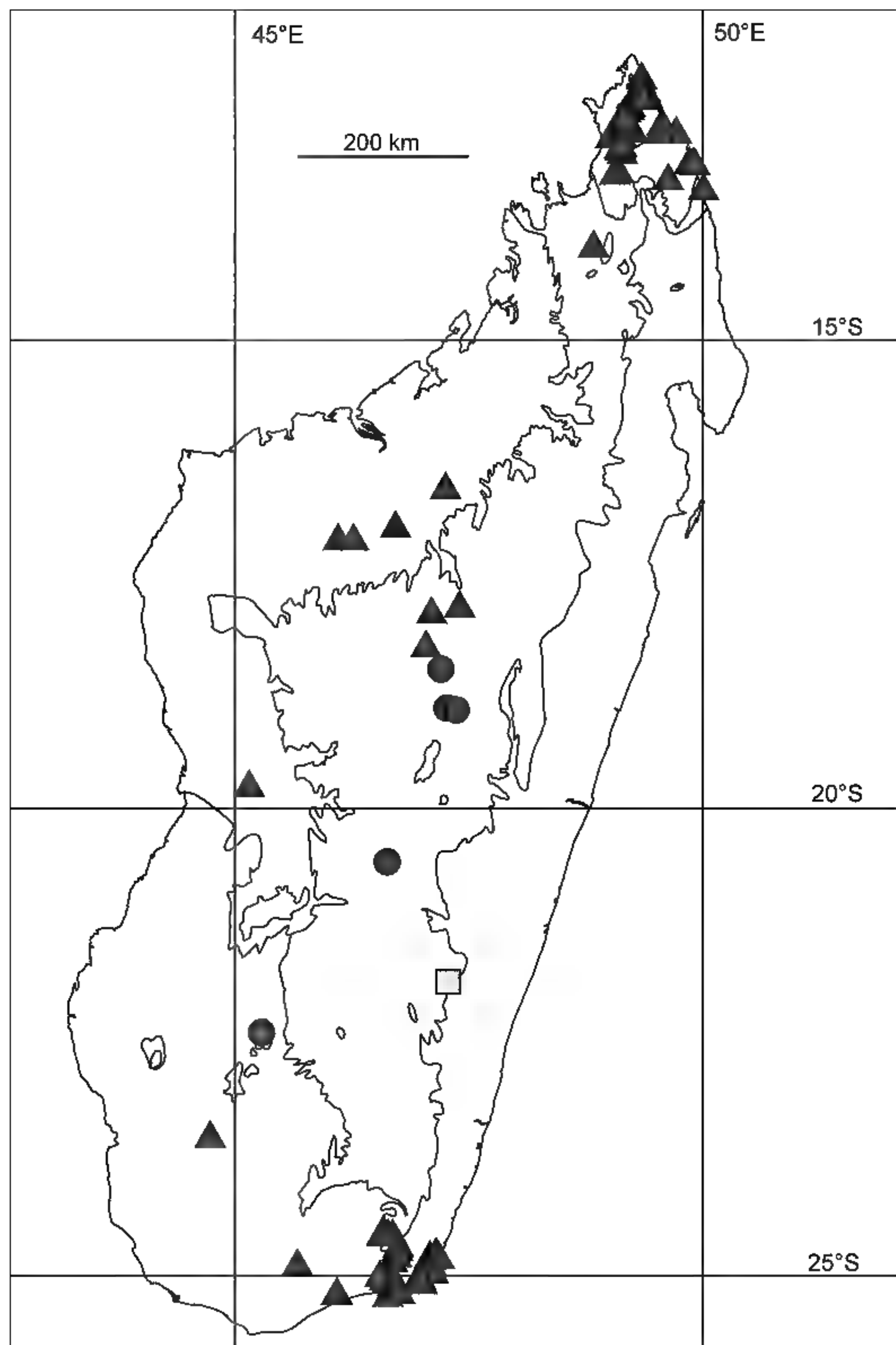

Figure 15. Geographic distribution of *Gnidia ambondrombensis* (Boiteau) Z. S. Rogers (■), *G. bojeriana* (Decne.) Gilg (●), and *G. daphnifolia* L. f. (▲).

EXCLUDED NAMES

Arthrosolen madagascariensis Endl., Gen. Pl. Suppl. 4(2): 63. 1848, nom. illeg. [– *Phaleria octandra* (L.) Baill., Adansonia 11: 321. 1875].

Endlicher published *Arthrosolen madagascariensis* with reference to Lamarck's (1786: 254) description of *Dais octandra* L., a name that has been recognized by Rye (1990) as a synonym of the widespread Pacific species *Phaleria octandra* (L.) Baill.

Dais rhamnifolia Baill., Hist. Phys. Madagascar 35(5) [Atlas 3], pl. 318. 1895. TYPE: "Madagascar" (type, pl. 318!, Baillon in Grandidier, 1895) [– *Dais glaucescens* Decne. in C. A. Mey., Ann. Sci. Nat. Bot., sér. 2, 20: 51. 1843].

The protologue of *Dais rhamnifolia* Baill. consisted of a beautifully illustrated diagnostic plate engraved with "Madagascar" and the species name without authorship. *Dais rhamnifolia* taxonomically belongs to the earlier named species *D. glaucescens*.

Gnidia daphnifolia L. f. var. *hirsuta* L. f., Suppl. Pl. 225. 1782. *Dessenia hirsuta* (L. f.) Raf., Fl.

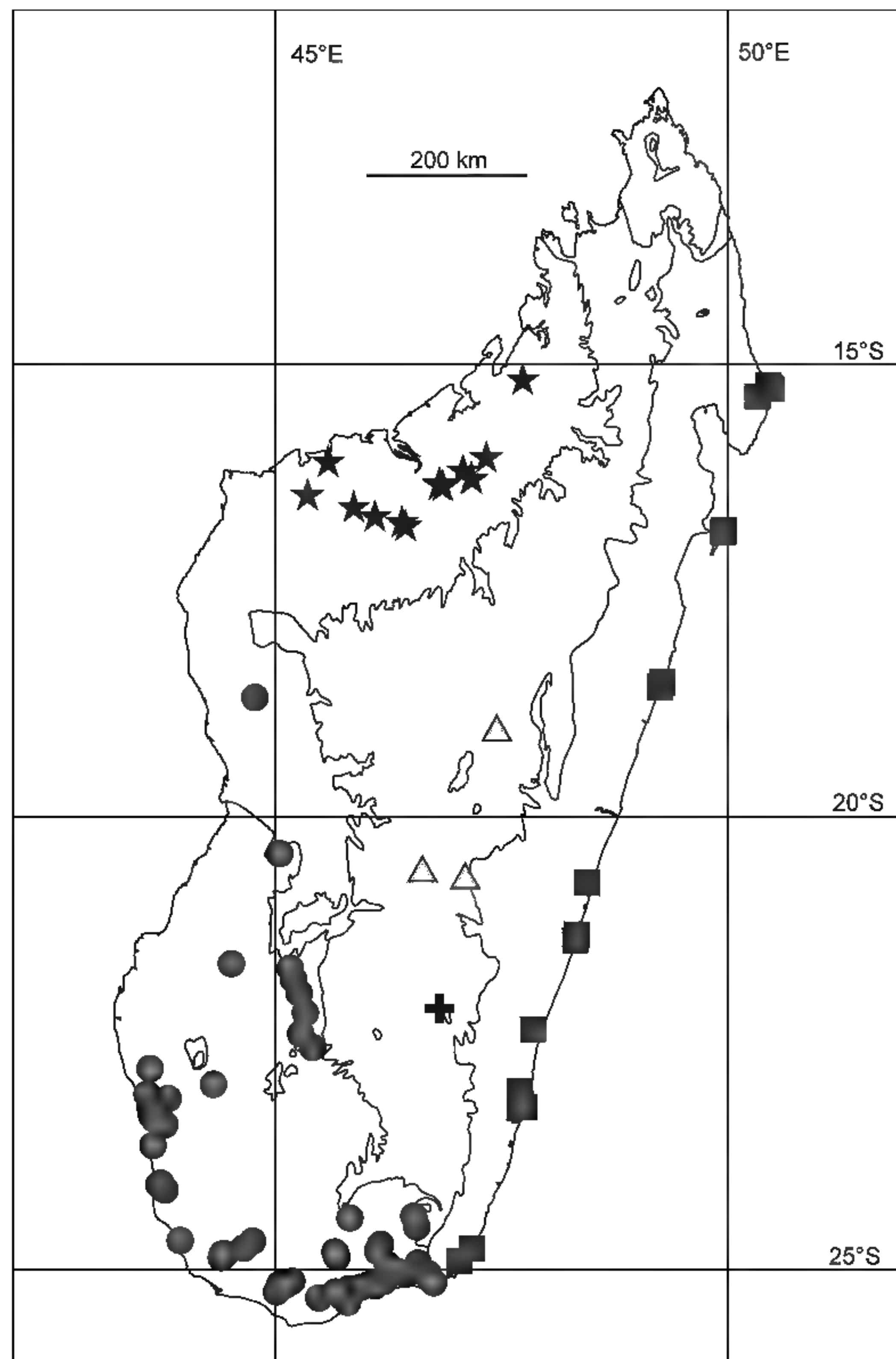

Figure 16. Geographic distribution of *Gnidia danguyana* Leandri (■), *G. gilbertae* Drake (★), *G. linearis* (Leandri) Z. S. Rogers (●), plants of *G. linearis* that were possibly cultivated or escaped from cultivation (▲), and *G. perrieri* (Leandri) Z. S. Rogers (⊕).

Tellur. 4: 106. 1838. TYPE: *Hb. Smith No. 688.1* (lectotype, designated by Rogers in Rogers & Spencer, 2006: 486, LINN-SM!) [≡ *Gnidia capitata* L. f., Suppl. Pl. 224. 1782].

Gnidia daphnifolia var. *hirsuta*, and most likely the material on which it was based, was mistakenly attributed to Madagascar by Linnaeus (1782: 225) and was apparently used as the original material in the description of *G. capitata* L. f., an African species described on the previous page (Linnaeus, 1782: 224). The name was therefore designated as the lectotype of *G. capitata* in Rogers and Spencer (2006). *Gnidia daphnifolia* var. *glabra* pertains to a Malagasy species and is based on the same original material as the binomial, *G. daphnifolia* (Rogers & Spencer, 2006; see above under that species).

Lasiosiphon cuneatus Decne., Voy. Inde 4: 149. 1844. [– *Gnidia* sp.?].

Decaisne (1844: 149) published a scant description in the protologue with reference to "*Dais cuneata*

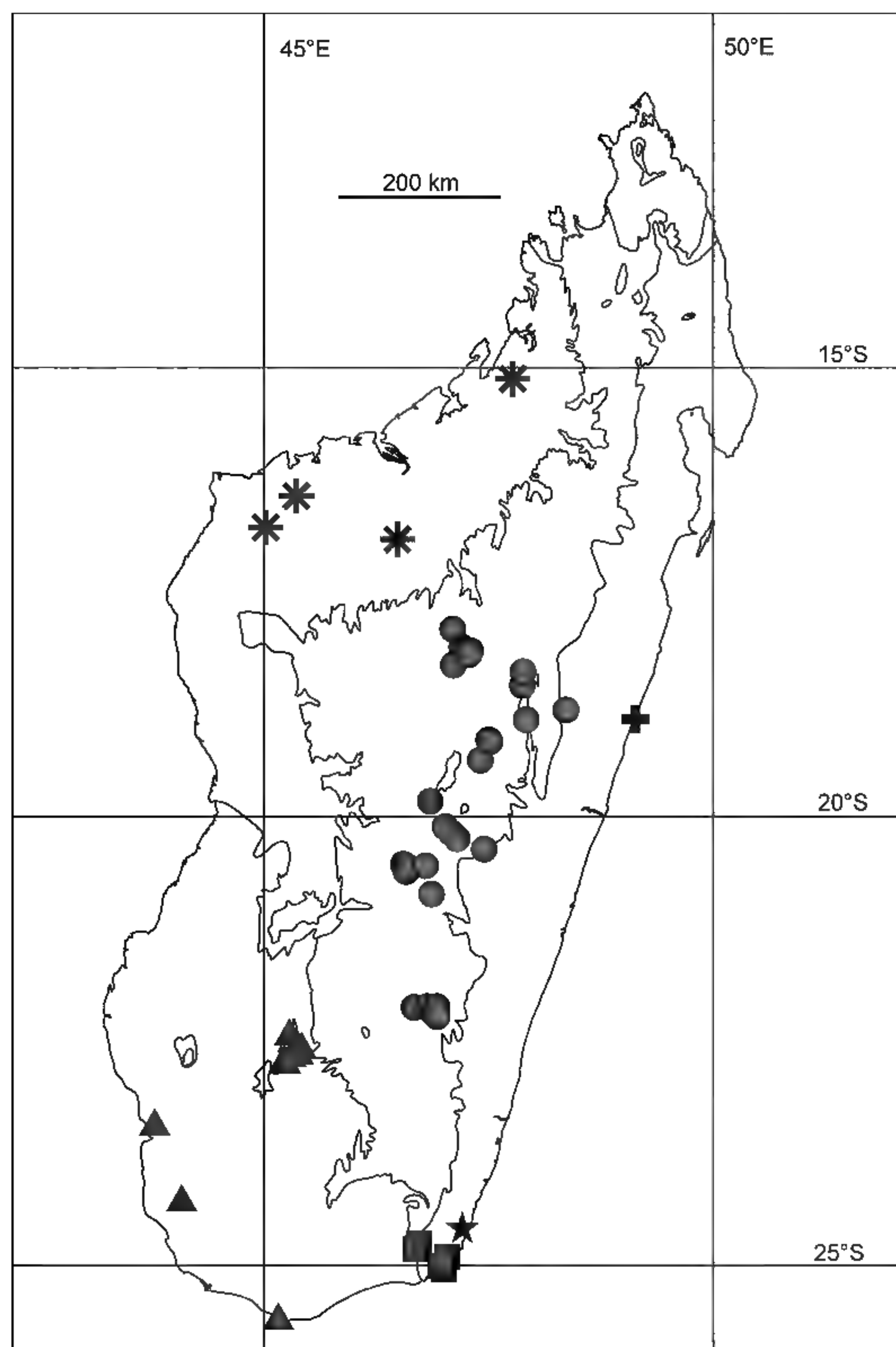

Figure 17. Geographic distribution of *Gnidia decaryana* Leandri (■), *G. gnidioides* (Baker) Domke (●), *G. humbertii* (Leandri) Z. S. Rogers (▲), *G. neglecta* Z. S. Rogers (✚), *G. occidentalis* (Leandri) Z. S. Rogers (*), and *G. razakamalalana* Z. S. Rogers (★).

Lamk., l.c.,” which supposedly referred to a name given on page 255 of the second volume of Lamarck’s *Encyclopédie Méthodique* (1786). Apparently, Lamarck never actually published the *Dais* name, and Decaisne might have instead been trying to cite a Lamarckian manuscript name. *Lasiosiphon cuneatus* Decne. was treated as an insufficiently known species by Meisner (1857: 599) and Leandri (1930a: 1042; 1931a: 676), and I have not been able to find any relevant original material for the name. The protologue description lacks sufficient diagnostic characters to determine the affinity of this taxon within the Thymelaeaceae.

Lasiosiphon rhamnifolius Baker, J. Linn. Soc., Bot. 25: 343. 1890, as “*Lasiosiphon? rhamnifolius*.”
TYPE: Madagascar. Vonizongo distr., s.d., *Baron 5115* (holotype, K!; isotypes, P [2]!) [— *Dais glaucescens* Decne. in C. A. Mey., Ann. Sci. Nat. Bot., sér. 2, 20: 51. 1843].

The original material of *Lasiosiphon rhamnifolius* belongs taxonomically to *Dais glaucescens*.

Literature Cited

- Aymonin, G. G. 1962. Quelques Thymélacées de rocailles montagnardes, III.—*Wikstroemia* et *Gnidia*. Pl. Mont. 3: 180–185.
- . 1965. Diversification, répartition et endémisme chez quelques groupes de Thymélacées de la flore africano-malgache. Compt. Rend. Sommaire Séances Soc. Biogéogr., no. 365: 6–21.
- . 1966a. Thymélacées. Pp. 35–95 in A. Aubréville (editor), Flore du Gabon, Vol. 11. Muséum National d’Histoire Naturelle, Paris.
- . 1966b. Thymélacées. Pp. 3–86 in A. Aubréville (editor), Flore du Cameroun, Vol. 5. Muséum National d’Histoire Naturelle, Paris.
- . 1966c. Sur un *Gnidia* (Thymélacées) à inflorescence complexe du Cameroun. Bull. Soc. Bot. France 112: 321–325.
- Baillon, H. 1875. Histoire des Plantes, Vol. 6. L. Librairie Hachette et Cie, Paris.
- Baker, J. G. 1883. Contributions to the flora of Madagascar, part III. J. Linn. Soc., Bot. 20: 237–303.
- Beaumont, A. J., T. J. Edwards & F. R. Smith. 2001a. Leaf and bract diversity in *Gnidia* (Thymelaeaceae): Patterns and taxonomic value. Syst. Geogr. Pl. 71: 399–418.
- , ——— & ———. 2001b. Patterns of diversity among involucral bracts, inflorescences and flowers in *Gnidia* (Thymelaeaceae). Syst. Geogr. Pl. 71: 419–431.
- Bredenkamp, C. L. & J. B. P. Beyers. 2003. Thymelaeaceae. Pp. 928–935 in G. Germishuizen & N. L. Meyer (editors), Plants of Southern Africa: An Annotated Checklist. Strelitzia 14, National Botanical Institute, Pretoria.
- Consiglio, T., G. E. Schatz, G. McPherson, P. P. Lowry II, J. Rabenantoandro, Z. S. Rogers, R. Rabevohitra & D. Rabehevitra. 2006. Deforestation and plant diversity of Madagascar’s littoral forests. Conservation Biol. 20: 1799–1803.
- Cornet, A. 1974. Essai de cartographie bioclimatique à Madagascar. Not. Explic. ORSTOM No. 55.
- Decaisne, J. 1844. Plantae Rariores, quas in India orientali. Pp. 57–183 in V. Jacquemont (editor), Voyage dans l’Inde, Vol. 4. Firmin-Didot, Paris.
- Domke, W. 1934. Untersuchungen über die systematische und geographische Gliederung der Thymelaeaceen. Biblioth. Bot. 27(111): 1–151.
- Dorr, L. J. 1997. Plant Collectors in Madagascar and the Comoro Islands. Royal Botanic Gardens, Kew.
- Engler, H. G. A. 1921. Thymelaeaceae. Pp. 625–642 in H. G. Engler & C. G. Prance (editors), Die Vegetation der Erde, Vol. 9, Die Pflanzenwelt Afrikas, band 3, heft 2. Leipzig.
- Estragon, M. 1933. Les industries locales, la fabrication du papier Antaimoro. Rev. Madagasc. 4: 59–62.
- Gastaldo, P. 1969. Adumbratio Florae Aethiopicae, 19. Thymelaeaceae. Webbia 24: 337–389.
- Gilg, E. 1894. Thymelaeaceae. Pp. 216–245 in A. Engler & K. Prantl (editors), Die natürlichen Pflanzenfamilien, Vol. 3, 6a. W. Engelmann, Leipzig.
- Grandidier, A. 1895. Histoire Physique, Naturelle et Politique de Madagascar, Histoire Naturelle des Plantes, Vol. 35, Tome 5 (Atlas 3), part 3, fasc. 38. Imprimerie nationale, Paris.
- . 1896. Histoire Physique, Naturelle et Politique de Madagascar, Histoire Naturelle des Plantes, Vol. 35, Tome 5 (Atlas 3), part 3, fasc. 40. Imprimerie nationale, Paris.

- Hallé, F., R. A. A. Oldeman & P. B. Tomlinson. 1978. *Tropical Trees and Forests: An Architectural Analysis*. Springer-Verlag, Berlin.
- Heads, M. J. 1990. A revision of the genera *Kelleria* and *Drapetes* (Thymelaeaceae). *Austral. Syst. Bot.* 3: 595–652.
- Heinig, K. H. 1951. Studies in the floral morphology of the Thymelaeaceae. *Amer. J. Bot.* 38: 113–132.
- Herber, B. E. 2003. Thymelaeaceae. Pp. 373–396 in K. Kubitzki (editor), *The Families and Genera of Vascular Plants, Vol. 5: Flowering Plants. Dicotyledons. Malvales, Capparales and Non-betalain Caryophyllales*. Springer, Berlin.
- IUCN. 2001. IUCN Red List Categories and Criteria, Version 3.1. Prepared by the IUCN Species Survival Commission. IUCN, Gland, Switzerland, and Cambridge, United Kingdom.
- Lamarck, J. B. 1786. *Encyclopédie Méthodique, Botanique, Vol. 2*. Paris.
- Leandri, J. 1930a. Descriptions de Thyméléacées de Madagascar (*Lasiosiphon*, *Arthrosolen*). *Bull. Soc. Bot. France* 76: 1039–1043.
- . 1930b. Thyméléacées nouvelles de Madagascar. *Bull. Mus. Natl. Hist. Nat., sér. 2, 1*: 435–437.
- . 1931a. Révision des Thyméléacées de Madagascar. *Bull. Mus. Natl. Hist. Nat., sér. 2, 2*: 668–676.
- . 1931b. Révision des Thyméléacées de Madagascar. *Bull. Mus. Natl. Hist. Nat., sér. 2, 3*: 148–160.
- . 1947. Nouvelles observations sur les Thyméléacées de Madagascar. *Notul. Syst. (Paris)* 13: 38–55.
- . 1950. Thyméléacées (family 146). Pp. 1–40 in H. Humbert (editor), *Flore de Madagascar et des Comores (Plantes Vasculaires)*. Firmin-Didot, Paris.
- Linnaeus, C. (filius). 1782. *Supplementum Plantarum, Impensis Orphanotropei, Brunswick*.
- McNeill, J., F. R. Barrie, H. M. Burdet, V. Demoulin, D. L. Hawksworth, K. Marhold, D. H. Nicolson, J. Prado, P. C. Silva, J. E. Skog, J. H. Wiersema & N. J. Turland (editors). 2006. *International Code of Botanical Nomenclature (Vienna Code)*. *Regnum Veg.* 146.
- Meisner, C. F. 1857. Ordo CLXVII. Thymelaeaceae. Pp. 493–605 in A. P. de Candolle, *Prodromus Systematis Naturalis Regni Vegetabilis, Vol. 14*. Victoris Masson, Paris.
- Miller, J. S. 2002. A revision of *Ehretia* (Boraginaceae) for Madagascar and the Comoro Islands. *Adansonia, sér. 3, 24*: 137–157.
- Moore, S. L. M. 1920. *Plantarum Mascarensium Pugillus*. *J. Bot.* 58: 187–190.
- Pearson, H. H. W. 1910. Order CXVIII. Thymelaeaceae. Pp. 212–255 in W. T. Thiselton-Dyer, *Flora of Tropical Africa, Vol. 6*. L. Reeve & Co., London.
- Peterson, B. 1959. Some interesting species of *Gnidia*. *Bot. Not.* 112: 465–480.
- . 1978. Thymelaeaceae. Pp. 1–35 in R. M. Polhill (editor), *Flora of Tropical East Africa*. Whitefriars Press, London.
- . 2006. Thymelaeaceae. Pp. 85–117 in G. W. Pope, R. M. Polhill & E. S. Martins (editors), *Flora Zambesiaca, Vol. 9, Part 3*. Royal Botanic Gardens, Kew.
- Rabakonandrianina, E. & G. D. Carr. 1987. Chromosome numbers of Madagascar plants. *Ann. Missouri Bot. Gard.* 74: 123–125.
- Randriatavy, L. D. 1998. Utilisation de la Plante *Dais glaucescens* (Thymelaeaceae). M.S. Thesis, University of Antananarivo, Antananarivo.
- Regel, E. 1860. *Catalogus Plantarum quae in Horto Aksakoviano Coluntur*. Typography of State Ministers, St. Petersburg.
- Robyns, A. 1975. Thymelaeaceae. Pp. 1–68 in P. Bamps (editor), *Flore d'Afrique Centrale (Zaire-Rwanda-Burundi)*. Jardin Botanique National de Belgique, Brussels.
- Rogers, Z. S. 2004. A revision of *Stephanodaphne* Baill. (Thymelaeaceae). *Adansonia, sér. 3, 26*: 7–35.
- . 2005. A revision of *Octolepis* Oliv. (Thymelaeaceae, Octolepidoideae). *Adansonia, sér. 3, 27*: 89–111.
- . 2006. A new species of Malagasy *Gnidia* and the lectotypification of *Octolepis decalepis* (Thymelaeaceae). *Adansonia, sér. 3, 28*: 155–160.
- & M. A. Spencer. 2006. Typification of Linnaean and Linnaeus filius plant names in Thymelaeaceae. *Taxon* 55: 483–488.
- Rye, B. L. 1990. Thymelaeaceae (excluding *Kelleria*). Pp. 122–215 in A. S. George (editor), *Flora of Australia, Vol. 18*. Australian Government Publishing Service, Canberra.
- Schatz, G. E. 2000. Endemism in the Malagasy tree flora. Pp. 1–9 in W. R. Lourenço & S. M. Goodman (editors), *Diversity and Endemism in Madagascar*. *Mém. Soc. Biogéogr., Paris*.
- & P. P. Lowry II. 2002. A synoptic revision of the genus *Buxus* L. (Buxaceae) in Madagascar and the Comoro Islands. *Adansonia, sér. 3, 24*: 179–196.
- & M. Lescot. 2009. Gazetteer to Malagasy Botanical Collecting Localities. Missouri Botanical Garden website, <<http://www.mobot.org/MOBOT/Research/madagascar/gazetteer/>>, accessed 13 April 2009.
- , P. P. Lowry II & A.-E. Wolf. 2001. Endemic families of Madagascar. VII. A synoptic revision of *Leptolaena* Thouars sensu stricto (Sarcoleaceae). *Adansonia, sér. 3, 23*: 171–189.
- Scott Elliot, G. F. 1891. *Lasiosiphon hildebrandtii*. *J. Linn. Soc., Bot.* 29: 47.
- Staner, P. 1935. Les Thyméléacées de la Flore du Congo Belge. *Bull. Jard. Bot. État* 13: 321–372.
- Townsend, C. C. 1981. Thymelaeaceae. Pp. 501–511 in M. D. Dassanayake (editor), *A Revised Handbook to the Flora of Ceylon, Vol. 2*. Amerind Publishing Co., New Delhi.
- Van der Bank, M., M. F. Fay & M. W. Chase. 2002. Molecular phylogenetics of Thymelaeaceae with particular reference to African and Australian genera. *Taxon* 51: 329–339.
- Wright, C. H. 1906. *Gnidia mollis*. *Bull. Misc. Inform.* 1906: 23.
- . 1915. Order CXVIII. Thymelaeaceae. Pp. 1–81 in W. T. Thiselton-Dyer (editor), *Flora Capensis, Vol. 5, Sect. 2, Pt. 1*. L. Reeve & Co., London.

APPENDIX 1. List of recognized species of Malagasy *Gnidia*.

1. *Gnidia ambondrombensis* (Boiteau) Z. S. Rogers
2. *Gnidia bojeriana* (Decne.) Gilg
3. *Gnidia danguyana* Leandri
4. *Gnidia daphnifolia* L. f.
5. *Gnidia decaryana* Leandri
6. *Gnidia gilbertae* Drake
7. *Gnidia gnidioides* (Baker) Domke
8. *Gnidia hibbertioides* (S. Moore) Z. S. Rogers
9. *Gnidia humbertii* (Leandri) Z. S. Rogers
10. *Gnidia linearis* (Leandri) Z. S. Rogers
11. *Gnidia neglecta* Z. S. Rogers
12. *Gnidia occidentalis* (Leandri) Z. S. Rogers
13. *Gnidia perrieri* (Leandri) Z. S. Rogers

9900 (3); 17671 [— Réserves Naturelles 8874] (3); 18572 (2); 18622 (10); 25234 (10); 26490 (4); 28646 (3); 28650 (5); 34923 [— Rabevohitra 3191] (4). Straka s.n. [18 Sep. 1957] (6); s.n. (10). Swingle 7746 (4).

Thompson s.n. (4); **s.n. (8)**. Thouars s.n. (3).

van Nek 1942 (4). van der Werff 13577 (7). Vesco s.n. [1850] (4). Viguier 1800 (7).

Waterlot **331 (4)**; **s.n. [June 1915] (10)**; **s.n. [May 1916] (10)**. White s.n. [15 Sep. 1929] (10).

Zarucchi 7572 (10).

APPENDIX 3. List of names and synonyms (including excluded names). Accepted names are presented in **boldface** and synonyms are *italicized*.

Arthrosolen C. A. Mey. — **Gnidia** L.

gnidioides (Baker) Leandri = **Gnidia gnidioides** (Baker) Domke

madagascariensis Endl. [— **Phaleria octandra** (L.) Baill., excluded name]

Dais gnidioides Baker = **Gnidia gnidioides** (Baker) Domke

madagascariensis Lam. — **Gnidia daphnifolia** L. f.

pubescens Lam. — **Gnidia daphnifolia** L. f.

rhamnifolia Baill. [— **Dais glaucescens** Decne. in C. A. Mey., excluded name]

Dessenia Adans. = **Gnidia** L.

daphnifolia (L. f.) Raf. — **Gnidia daphnifolia** L. f.

hirsuta (L. f.) Raf. [= **Gnidia capitata** L. f., African taxon]

Gnidia L.

ambondrombensis (Boiteau) Z. S. Rogers

bakeri Gilg = **Gnidia gnidioides** (Baker) Domke

bojeriana Baill. — **Gnidia bojeriana** (Decne.) Gilg

bojeriana (Decne.) Gilg

danguyana Leandri

daphnifolia L. f.

var. *glabra* L. f. = **Gnidia daphnifolia** L. f.

var. *hirsuta* L. f. [= **Gnidia capitata** L. f., African taxon]

decaryana Leandri

gilbertae Drake

gnidioides (Baker) Domke

hibbertioides (S. Moore) Z. S. Rogers

hildebrandtii (Scott-Elliot) Gilg — **Gnidia daphnifolia** L. f.

humbertii (Leandri) Z. S. Rogers

linearis (Leandri) Z. S. Rogers

madagascariensis (Lam.) Gilg — **Gnidia daphnifolia** L. f.

neglecta Z. S. Rogers

occidentalis (Leandri) Z. S. Rogers

perrieri (Leandri) Z. S. Rogers

pubescens Baill. — **Gnidia daphnifolia** L. f.

razakamalana Z. S. Rogers

rostrata (Meisn.) Drake — **Gnidia daphnifolia** L. f.

Lasiosiphon Fresen. — **Gnidia** L.

ambondrombense Boiteau = **Gnidia ambondrombense** (Boiteau) Z. S. Rogers

baronii Baker — **Gnidia daphnifolia** L. f.

bojerianus Decne. = **Gnidia bojeriana** (Decne.) Gilg

carinatus (Leandri) Leandri — **Gnidia daphnifolia** L. f.

cuneatus Decne. [excluded name] — **Gnidia** sp.?

decaryi Leandri — **Gnidia linearis** (Leandri) Z. S. Rogers

var. *erectus* Leandri — **Gnidia linearis** (Leandri) Z. S. Rogers

var. *linearis* Leandri = **Gnidia linearis** (Leandri) Z. S. Rogers

var. *littoralis* Leandri — **Gnidia linearis** (Leandri) Z. S. Rogers

var. *tenerifolia* Leandri — **Gnidia linearis** (Leandri) Z. S. Rogers

dumetorum Leandri — **Gnidia daphnifolia** L. f.

erectus (Leandri) Leandri — **Gnidia linearis** (Leandri) Z. S. Rogers

hibbertioides S. Moore = **Gnidia hibbertioides** (S. Moore) Z. S. Rogers

hildebrandtii Scott-Elliot — **Gnidia daphnifolia** L. f.

humbertii Leandri = **Gnidia humbertii** (Leandri) Z. S. Rogers

linearis Leandri = **Gnidia linearis** (Leandri) Z. S. Rogers

madagascariensis (Lam.) Decne. — **Gnidia daphnifolia** L. f.

var. *angustifolius* Leandri — **Gnidia daphnifolia** L. f.

var. *baronii* (Baker) Leandri — **Gnidia daphnifolia** L. f.

var. *hildebrandtii* (Scott-Elliot) Leandri — **Gnidia daphnifolia** L. f.

var. *mandrarensis* Leandri — **Gnidia daphnifolia** L. f.

var. *parvifolius* Leandri = **Gnidia daphnifolia** L. f.

var. *rostratus* (Meisn.) Leandri — **Gnidia daphnifolia** L. f.

multifolius (Leandri) Leandri = **Gnidia daphnifolia** L. f.

occidentalis Leandri = **Gnidia occidentalis** (Leandri) Z. S. Rogers

perrieri Leandri = **Gnidia perrieri** (Leandri) Z. S. Rogers

pubescens (Lam.) Decne. — **Gnidia daphnifolia** L. f.

var. *carinatus* Leandri — **Gnidia daphnifolia** L. f.

var. *multifolius* Leandri — **Gnidia daphnifolia** L. f.

rhamnifolius Baker [— **Dais glaucescens** Decne. in C. A. Mey., excluded name]

rostratus Meisn. — **Gnidia daphnifolia** L. f.

saxatilis Scott-Elliot — **Gnidia daphnifolia** L. f.

suffrutescens Leandri — **Gnidia daphnifolia** L. f.

waterlotii Leandri — **Gnidia daphnifolia** L. f.

www.mbgpress.org

CONTENTS

Biogeography and Phylogeny of <i>Cardamine</i> (Brassicaceae) _____	
<i>Tor Carlsen, Walter Bleeker, Herbert Hurka, Reidar Elven & Christian Brochmann</i>	215
A Taxonomic Revision of the <i>Syringa pubescens</i> Complex (Oleaceae) _____	
_____ <i>Chen Jin-Yong, Zhang Zuo-Shuang & Hong De-Yuan</i>	237
A Synopsis of South American <i>Echeandia</i> (Anthericaceae) _____	<i>Robert William Cruden</i> 251
Three New Species and a Nomenclatural Synopsis of <i>Urera</i> (Urticaceae) from Mesoamerica	
_____ <i>Alexandre K. Monro & Alexander Rodríguez</i>	268
A Review of the Genus <i>Distictella</i> (Bignoniaceae) _____	<i>Amy Pool</i> 286
A Revision of Malagasy <i>Gnidia</i> (Thymelaeaceae, Thymelaeoideae)	<i>Zachary S. Rogers</i> 324

Cover illustration. *Galianthe longifolia* (Standl.) E. L. Cabral, drawn by Laura Simón.

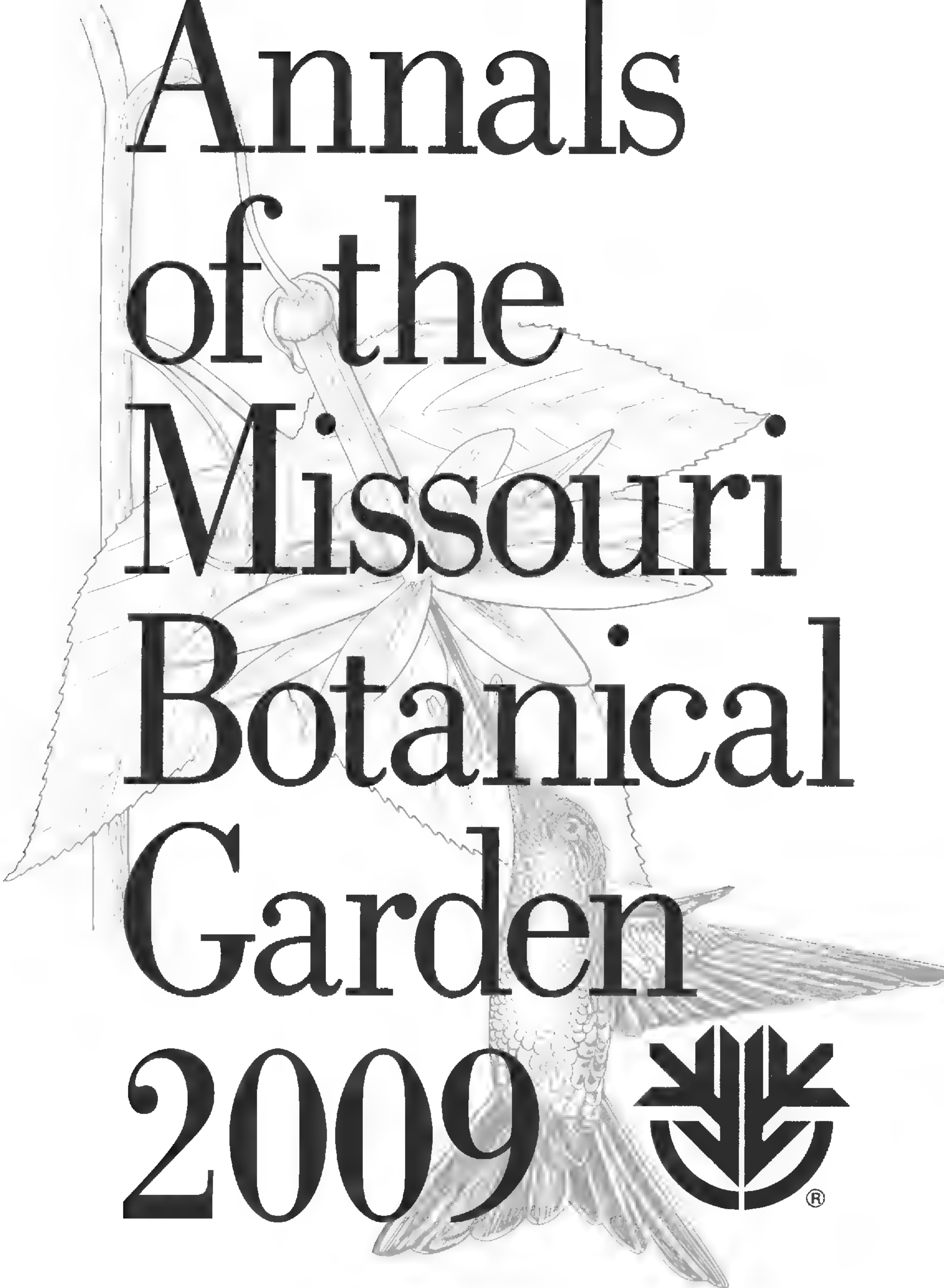
A detailed botanical illustration in the background features a large, serrated leaf on the left and a central structure resembling a bird's tail or a complex floral part. The text is overlaid on this illustration.

**Annals
of the
Missouri
Botanical
Garden
2009**



Volume 96

Number 3

The Annals, published quarterly, contains papers, primarily in systematic botany, contributed from the Missouri Botanical Garden, St. Louis. Papers originating outside the Garden will also be accepted. All manuscripts are peer-reviewed by qualified, independent reviewers. Instructions to Authors are printed in the back of the last issue of each volume and are also available online at www.mbgpress.org.

Editorial Committee

Victoria C. Hollowell
Scientific Editor,
Missouri Botanical Garden

Beth Parada
Managing Editor,
Missouri Botanical Garden

Allison M. Brock
Associate Editor,
Missouri Botanical Garden

Tammy Charron
Editorial Assistant,
Missouri Botanical Garden

Cirri Moran
Press Coordinator,
Missouri Botanical Garden

Roy E. Gereau
Latin Editor,
Missouri Botanical Garden

Ihsan A. Al-Shehbaz
Missouri Botanical Garden

Gerrit Davidse
Missouri Botanical Garden

Peter Goldblatt
Missouri Botanical Garden

Gordon McPherson
Missouri Botanical Garden

Charlotte Taylor
Missouri Botanical Garden

Henk van der Werff
Missouri Botanical Garden

For subscription information contact ANNALS OF THE MISSOURI BOTANICAL GARDEN, % Allen Marketing & Management, P.O. Box 1897, Lawrence, KS 66044-8897. Subscription price for 2009 is \$175 per volume U.S., \$185 Canada & Mexico, \$210 all other countries. Four issues per volume. The journal *Novon* is included in the subscription price of the *Annals*.

annals@mobot.org (editorial queries)

<http://www.mbgpress.org>

The *Annals* are abstracted and/or indexed in AGRICOLA (through 1994), APT Online, BIOSIS®, CAB Abstract/Global Health databases, ingenta, ISI® databases, JSTOR, Research Alert®, and Sci Search®.

The full-text of ANNALS OF THE MISSOURI BOTANICAL GARDEN is available online through BioOne™ (<http://www.bioone.org>).

© Missouri Botanical Garden Press 2009

The mission of the Missouri Botanical Garden is to discover and share knowledge about plants and their environment, in order to preserve and enrich life.

© This paper meets the requirements of ANSI/NISO Z39.48-1992 (Permanence of Paper).

Volume 96
Number 3
2009

Annals
of the
Missouri
Botanical
Garden



BIODIVERSITY AND
CONSERVATION IN THE ANDES:
INTRODUCTION^{1,2}

*Peter Møller Jørgensen*³

The Andes presents us with a long list of outstanding features. The adjectives, only occasionally qualified, that have been used to describe this mountain range are: longest, highest, deepest, roughest, flattest, steepest, wettest, driest, warmest, coldest, richest, poorest, youngest, and oldest. How do we present the biodiversity and conservation of such a varied region in a single day?

The 54th Annual Systematics Symposium of the Missouri Botanical Garden, "Biodiversity and Conservation in the Andes," made an attempt on 12–13 October 2007; however, with the nine papers published here as the symposium proceedings, we were only able to scratch the surface of the Andes. An understanding of the critical questions—what species exist where, why are they there, and where should conservation efforts be focused—is hampered by the scale and complexity that biodiversity displays in the

Andes; these are the same qualities that make the area so fascinating. We present here a series of interesting papers that will serve as inspiration for the development of further hypotheses, questions, and research on the subject of biodiversity and conservation in the Andes, which in turn, we hope, will lead to the implementation of successful conservation plans in the area.

The Andes has an extremely varied landscape with a diversity of geological features that developed in slow motion or rapid jumps over millions of years, as presented by Alan Graham (Missouri Botanical Garden) in the first morning lecture. On a geological timescale, the diverse and highly endemic páramo vegetation came into existence only recently (3.5 million years ago [Ma]). The combination of slow lift and violent volcanism and, consequently, young and old substrates often in close proximity, as well as the

¹This and the following nine papers are the proceedings of the 54th Annual Systematics Symposium of the Missouri Botanical Garden, "Biodiversity and Conservation in the Andes." The symposium was held 12–13 October 2007 at the Missouri Botanical Garden in St. Louis, Missouri, U.S.A. Peter Jørgensen served as editor of the proceedings.

²This was the 52nd Missouri Botanical Garden Annual Systematics Symposium to be supported by a grant from the National Science Foundation (grant DEB-0515933). Many persons from the Missouri Botanical Garden staff contributed to a successful and memorable day. Peter Raven, Olga Martha Montiel, and Iván Jiménez helped to find the speakers; Mick Richardson was responsible for the program and the smooth running of the symposium; Mary McNamara, Sandy Lopez, and Mary Merello helped with registration; Zubin Chandra (Information Technology) and William Guy (Facilities Support) provided assistance with computers and projectors; Mateo Unda put together the coffee break slide shows; Barbara Alongi made the program illustration; and Victoria C. Hollowell, Beth Parada, Allison Brock, and Tammy Charron (Missouri Botanical Garden Press) were responsible for the publication of the symposium proceedings. I also want to thank the speakers and reviewers for making this series of most interesting papers available—an important step in reaching a better understanding and ultimately a better management of the biodiversity of the Andes.

³Missouri Botanical Garden, P.O. Box 299, St. Louis, Missouri 63166-0299, U.S.A. peter.jorgensen@mobot.org.
doi: 10.3417/2009065

separations that are created by mountains and valleys, makes for a dynamic landscape on many scales and along numerous gradients that are immensely important for our understanding of biodiversity and conservation.

The Andes have created the driest (the Atacama Desert) and wettest (the Chocó rainforests) places on earth. The Atacama has been dry for more than 10 million years, while the Altiplano, just east of it, has undergone cycles of dry and wet periods as Christa Placzek (Purdue University) and her collaborators indicated in the second talk. It is fascinating that it never rains in northern Chile, while the salt flats of the nearby Altiplano have had a fluctuating precipitation regime for thousands of years linked to the El Niño–Southern Oscillation (ENSO) phenomenon.

Our knowledge of phylogeny and distribution, particularly in the Andes, is limited for many clades. One exception is the birds, and there are enough species to potentially reach a general notion that reflects both mechanistic ecological and historical evolutionary theory. Jon Fjeldså (University of Copenhagen) and collaborator did just that in the last morning session. They concluded that the upper forest limit plays a very important role in the diversification process, while small climatically stable areas near old human settlements have accumulated particularly high numbers of endemic birds.

Valleys, rivers, and ridges—are they all equally important as barriers for the distribution, isolation, and evolution of species? We include in these proceedings an invited paper by Jason Weir (University of Chicago), who was not able to participate in the symposium. In his paper, he evaluates high-endemism areas as useful conservation units, using genetic and phylogenetic techniques on both inter- and infra-specific variation. Lowland barriers were found to display the highest level of genetic differentiation, whereas above-tree-line barriers show less variation. Conservation recommendations were to place special emphasis on endemism areas separated by lowland barriers and deep interandean river valleys.

Moss spores float on the air and can cross barriers with an ease unlike vascular plants and even birds; they therefore are not governed by the same rules. Steven Churchill (Missouri Botanical Garden) wrote the second invited paper about moss diversity in the Andes. The group has traditionally been overdescribed, and many names have recently been reduced to synonymy. Endemism is still high and total richness

appears to be greatest at elevations of 2500–3000 m. In general, mosses contradict the usual negative relationship between latitude and species richness, but the narrow strip of Andean highlands and cloud forests harbors enough species to counteract the general tendency.

The Andean landscape has a nearly infinite amount of spatial barriers and provides ample opportunities for allopatric and sympatric speciation, but these barriers do not work with the same efficiency in time and space or for different taxonomic groups. A hummingbird-pollinated plant group is the subject of the paper by Lena Struwe (Rutgers University) and collaborators. Using newly developed software called Spatial Evolutionary and Ecological Vicariance Analysis (SEEVA), the evolutionary history and geography of the group are teased apart.

Why are there so many species in the tropics? This is a question that has occupied ecologists for several decades. Numerous hypotheses have been proposed, and few believe that there is a single explanation for the patterns that we detect. Trisha Distler (lecture presented by Iván Jiménez, both from the Missouri Botanical Garden) and collaborators tested the relative importance of the species-energy, spatial heterogeneity, and regional hypothesis as determinants in models that predict plant richness across large areas of South and Central America, using a large data set of collection data.

The Andes is one of the world's cradles of civilization; the Tiwanaku, the Inca, and many other groups were living in well-structured societies throughout the Andes long before the Spanish colonization. Kenneth Young (University of Texas) discussed the impact humans have had on biodiversity in the past and will continue to have in the future, with a focus on climatic changes in this region where large areas of the landscape matrix are devoted to agriculture.

Conservation of biodiversity without science is impossible, but how is scientific knowledge used in conservation? Carolina Murcia and Gustavo Kattan (Fundación EcoAndina) outlined a process where communication between the stakeholders is critical. It will be crucial to establish dynamic triangles of park managers, scientists, and conservation nongovernmental organizations, to encourage their cooperation so that scientific results can be quickly and efficiently applied in the field, and to secure that we all do the best possible job at conserving the biodiversity of the Andes.

THE ANDES: A GEOLOGICAL OVERVIEW FROM A BIOLOGICAL PERSPECTIVE

Alan Graham^{1,2}

ABSTRACT

Geological events of biological importance in the history of the Andes include their impact on global climates through an influence on atmospheric circulation, rainfall patterns, and the atmospheric concentration of CO₂; habitat diversification from lowlands through páramo to glaciated peaks; and migratory pathways ranging from discontinuous (mesic elements), highly discontinuous (páramo elements), barriers (to east-west migrations), to selective pathways (via the dry Andean valleys). The timing of these effects is a function of the uplift history of three (to nine) morphotectonic segments of the Andes resulting in (1) mostly lowland swamp and fluvial environments in the Cretaceous and Paleocene, (2) moderate uplands beginning in the Late Eocene (ca. 40 million years ago [Ma]), (3) appression of an offshore volcanic chain (the proto-Cordillera Occidental) in the Oligocene (ca. 30 Ma), (4) uplift of the proto-Cordillera Oriental and the Altiplano to about half their present altitude by the Middle Miocene (ca. 15 Ma), and (5) uplift of the remaining half within approximately the past 10 million years. The early appearance of a biological community recognizable as the Atacama Desert is estimated at ca. 15 Ma, and the beginnings of a páramo at ca. 3.5 Ma. Longer-term (Milankovitch) and shorter-term (Younger Dryas, Medieval warm/dry period, Little Ice Age, Heinrich, and Dansgaard-Oeschger [D-O]) climatic events, known initially from the high latitudes, are now widely recognized throughout Latin America, including the Andes. They document a dynamic physical environment from the Cretaceous through the Holocene and on all timescales.

Key words: Altiplano, Andes, Cretaceous, Eocene, Paleocene, páramo.

The Andes are one of the major physiographic features of the Earth. They are the longest mountain chain at nearly 9000 km and at the widest are 750 km in Bolivia. Only the Himalayas with Mount Everest (8848 m) are higher than the Andes with Cerro Aconcagua (6962 m; Fig. 1). Their geologic development over time (Cordani et al., 2000; Ramos & Aleman, 2000; Veblen et al., 2007) has modified global and regional climate by affecting atmospheric circulation and the distribution of rainfall, and by contributing larger or lesser amounts of CO₂ to the atmosphere, correlated with the waxing and waning of orogeny. More than 90% of the world's seismic energy is released at convergent margins (Oncken et al., 2006), and the Andean plate boundaries are a major outlet of this energy. The Andes also provide altitudinally zoned habitats from rainforest to páramo to glaciated peaks, an east-west differentiation into wetter and drier sides through rain shadow effects, a discontinuous north-south migratory pathway for mid-elevation mesic biotas, an even more discontinuous route for higher Andean and páramo elements, an east-west pathway for interchange of arid elements through the dry Andean valleys, and an extensive

range of edaphic diversity. Their rise during the Cretaceous and particularly in the Cenozoic also constituted a gradual but ultimately formidable vicariant event. The influence of altitudinal gradients on distribution patterns and evolutionary processes is complex, but a first step in achieving a better understanding of the relationship has been to recognize two categories of physical changes that occur with differences in altitude. One is altitude-specific, such as atmospheric pressure, temperature, and clear-sky turbidity (cloudiness). The other is more variable but, nonetheless, affects the first category: moisture, hours of sunshine, wind, season length, and edaphic factors. The distinction will be important eventually for more precisely modeling the effect of altitude on biotas, for example, like those on the Altiplano (Körner, 2007). Uplift of a feature of this magnitude is also affecting the CO₂ concentration of the atmosphere, and hence climates, by increased erosion of silicate rocks through chemical transformations, where, for example, wollastonite (CaSiO₃) is transformed to calcium carbonate (CaCO₃) and silicon dioxide (SiO₂) while capturing CO₂ from the atmosphere. The process runs in the direction of SiO₂

¹The author gratefully acknowledges Peter Raven and the organizers of the symposium, Olga Martha Montiel and Peter Jørgensen, for the opportunity to participate, Victoria C. Hollowell and the staff of the Missouri Botanical Garden Press for their editorial expertise, and Trisha Consiglio and Iván Jiménez of the Center for Conservation and Sustainable Development for advice on imaging and other matters. Anthony Orem provided many helpful suggestions on the geological aspects of the paper. The manuscript was reviewed by Henry Hooghiemstra, Peter Jørgensen, and Anthony Orme.

²Missouri Botanical Garden, P.O. Box 299, St. Louis, Missouri 63166-0200, U.S.A. alan.graham@mobot.org.
doi: 10.3417/2007146

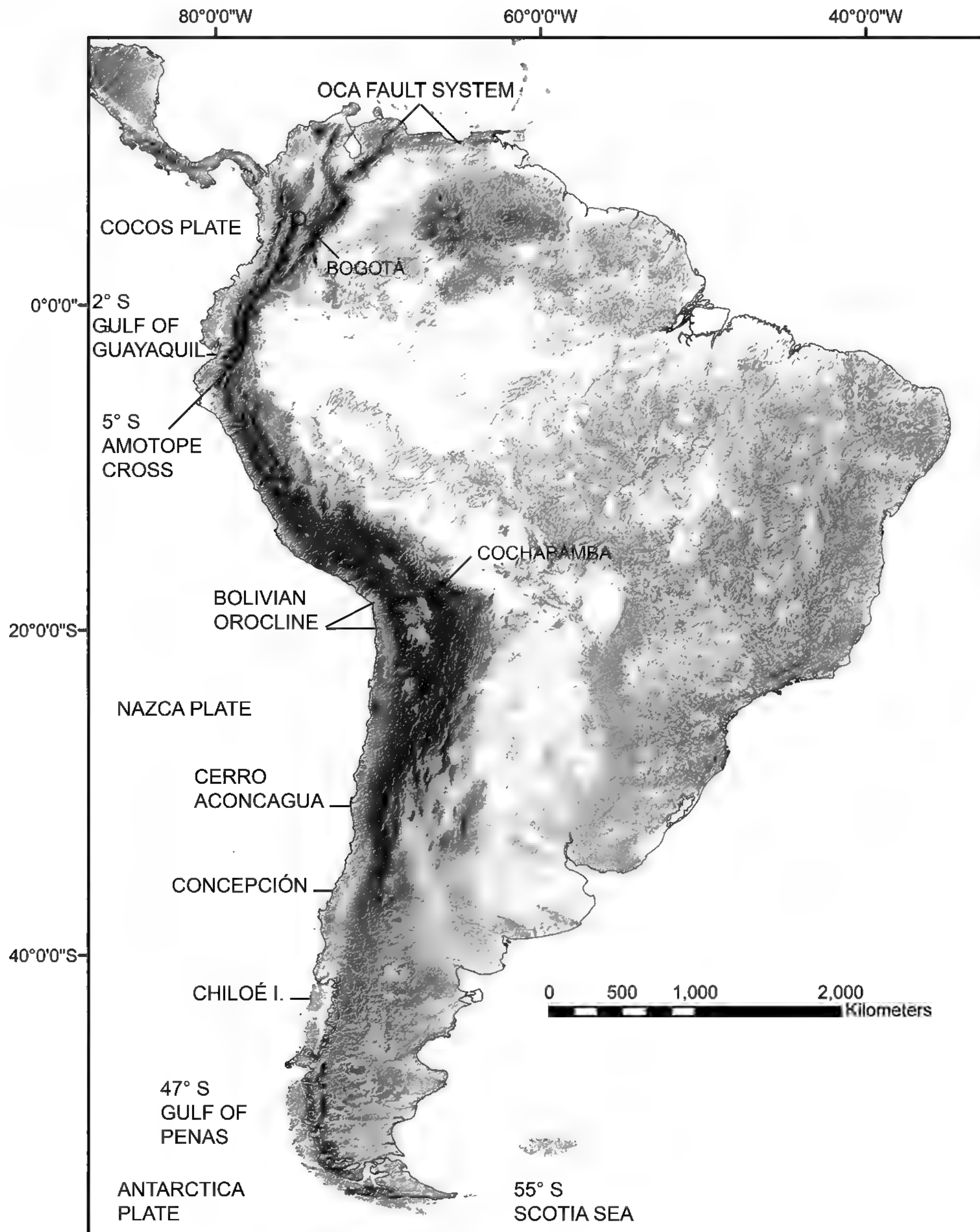

Figure 1. Physiographic map of South America with place names cited in the text using the U.S. Geological Survey Shuttle Radar Topographic Mission 90 m Digital Elevation Data (<<http://srtm.csi.cgiar.org>>).

during periods of mountain building and erosion, while in periods of metamorphism the process runs in the direction of CaSiO_3 and other silicate rocks. That is, more silicate rock is eroded at a faster pace with increased mountain building, resulting in an enhanced drawdown of CO_2 and augmenting the trend toward cooler climates of the Late Cenozoic.

The continuous curve of the Andes extending along the entire length of western South America belies the heterogeneity of the system. An early appreciation of

the complexity and an overview of the processes involved in their formation, ushering in the modern era of geologic studies, were provided by Dewey and Bird (1970). Subsequent investigations documented that various segments of the Andes differ in time of origin, the type and intensity of forces acting on them during various intervals, differential response to these forces depending on the thickness and composition of the rocks, the angle and rate of subduction, availability of lubricating sediments delivered into

the subduction zone (a function of climate), and the variable thickness of the underlying lithosphere. Gansser (1973) suggested the presently recognized subdivision of the mountains into the southern, central, and northern Andes, although some authors recognize seven sections (Moore & Twiss, 1995). These are convenient geographical separations, but they also reflect the varied tectonic forces that have defined the system (Fig. 2).

SEGMENTS AND FORCES

THE SOUTHERN ANDES

The southern Andes extend from the islands off southern South America in the Scotia Sea at 55°S to the Gulf of Penas at 47°S. They are the lowest in average elevation at just over 1 km, and their post-Paleozoic/Early Mesozoic history is slightly older than the mountains to the north, reflecting to some extent the opening of the Atlantic Ocean along the Mid-Atlantic Ridge. The opening began in the south at ca. 120 million years ago (Ma) and progressed northward until South America separated from Africa at ca. 90 Ma at the latitude of eastern Brazil between ca. 0°S and 10°S. Approximately 1 km of uplift in the southern Andes occurred between 17 and 14 Ma (Blisniuk et al., 2006). The peaks there, and the adjacent Patagonian lowlands, were also the earliest to be glaciated. Tills (unsorted glacial sediments) occur interbedded with basalts of Miocene to Quaternary age, and Mercer et al. (1975) found evidence of glaciation by 3.5 Ma.

The principal tectonic forces in the southern Andes are generated by the Antarctic Plate subducting beneath the South American Plate, but the region is also affected by jostling at the triple junction between the Nazca, South American, and Antarctic plates, and it is influenced to some extent by the Scotia Plate. Fragmented lands were accreted to the coast, and subduction of the Nazca Plate, mostly in the Cenozoic and particularly between 50 and 42 Ma and 25 and 10 Ma (Suárez et al., 2000; prior to the 14–10 Ma collision of the Chile Ridge with the subduction zone [Blisniuk et al., 2006]), has acted to pull the coast downward. Relative sea-level rise at various times, including the present interglacial, has contributed further to defining the archipelago extending southward from Chiloé Island (42°S). Recent research suggests that the Late Cenozoic era in the southern Andes has witnessed 18 to 20 glacial advances and retreats, under the influence of the 100,000-year eccentricity cycle of the Milankovitch variations, over the past few million years (Giles, 2005). There are also variations on a finer timescale (see later

discussion). This view of climate change, under a meandering Antarctic anticyclone (high-pressure) system covering an area during the glacial stages double that in the interglacials, and shifting climatic zones northward by 10° latitude, with accompanying fluctuations in sea level and water tables, along with tectonic events, reveal a dynamic physical environment of the southern Andes region, especially in the Late Cenozoic.

The biotic response has been equally dynamic as recorded in numerous spore and pollen diagrams from southern Chile and Argentina (e.g., Heusser, 2003; see summary in Graham, 2009). *Nothofagus* Blume pollen is present throughout most profiles associated with herbs, especially grasses, and there was tundra (*Sphagnum* L., Poaceae, *Acaena* Mutis ex L., Asteraceae, Caryophyllaceae, Cyperaceae, *Empetrum* L.) in the terminal Pleistocene. A grassy steppe developed in the early Holocene (*Chilotrimum* Cass., *Festuca* L., *Mulinum* Pers., *Stipa* L., *Verbena* L.), followed by *Nothofagus* (14,000 years BP) and closed *Nothofagus* forest (10,000 years BP). In the coldest intervals, temperatures are estimated to have been at least 5°C–6°C colder than at present in the lowlands and progressively colder in the highlands, assuming a minimal global average lapse rate of 6°C/km. The earliest occupation of Tierra del Fuego by people was ca. 13,000 years ago (Coronato et al., 1999) as suggested by an increase in charcoal in the stratigraphic records at about this time. The impact of these people on the vegetation, other than by fire, was minimal because they were primarily hunters of *Lama guanicoe* (Miotti & Salemme, 1999).

THE CENTRAL ANDES

The central Andes is the longest segment of the mountain range and comprises 5200 km of the 9000-km length. It is the widest at 750 km and the highest at 3.5–4 km, including Cerro Aconcagua at 6962 m. The central Andes extend from the Gulf of Penas northward to around a megashear zone called the Amotope Cross at ca. 2°S near the Gulf of Guayaquil.

Uplift of the central Andes during the Cenozoic is directly related to the subduction of the Nazca Plate. This plate can be subdivided into as many as seven smaller plates, each exerting related but separate subduction mechanics and each with somewhat different histories. Although it is an immensely complex region, the geology of some portions of the Bolivian section is well known due to two unrelated circumstances. One circumstance is military, dating from a war between Bolivia and Chile (1879–1884) and subsequent border disputes that continue to the present; the other is economic, relating to the

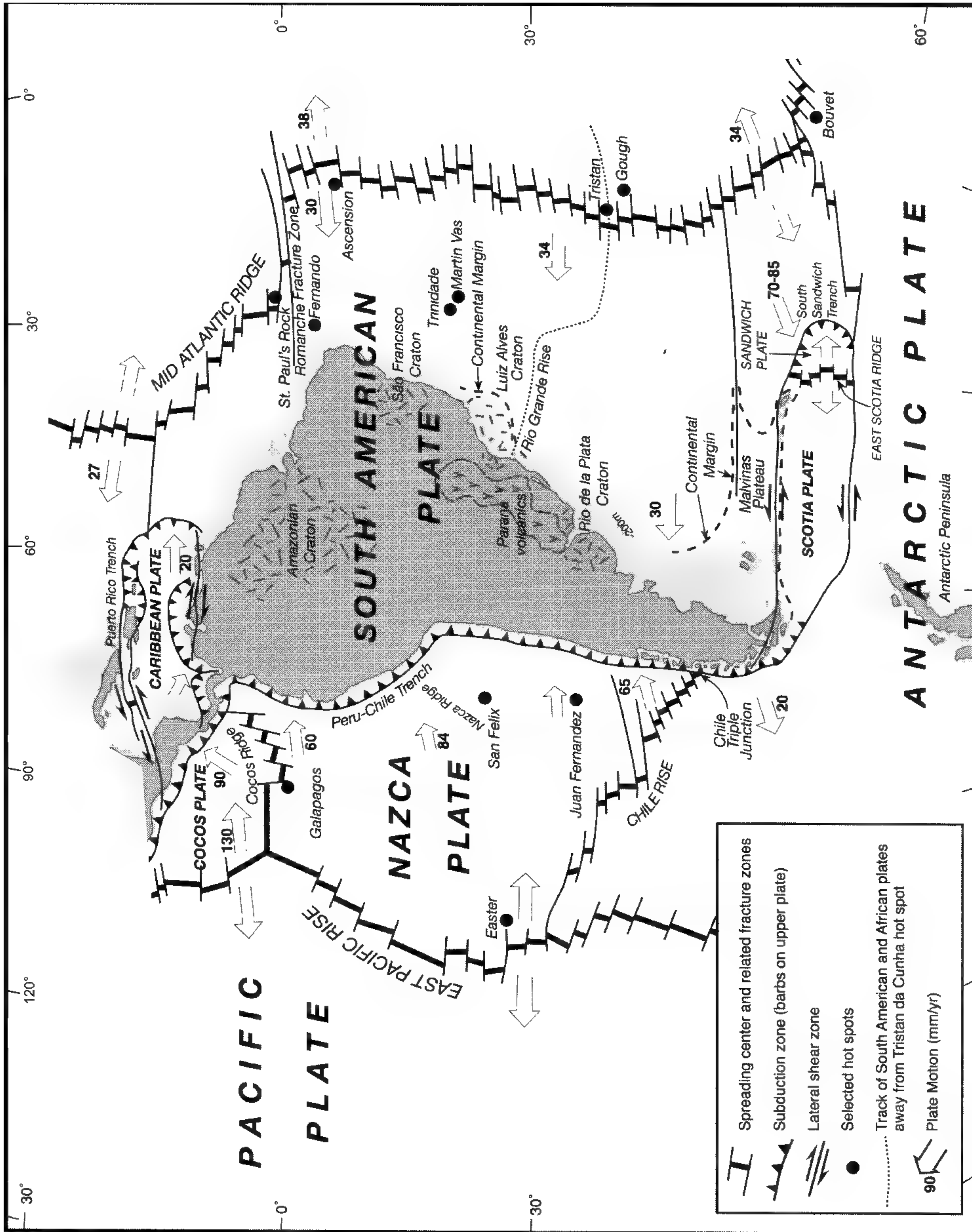

Figure 2. Principal plates acting on South America and the Andes. From Orme (2007a: fig. 1.1, see also fig. 1.2; 2007b: figs. 2.2, 2.4); used with permission of Oxford University Press, Oxford.

extensive deposits of copper, gold, iron, silver, and tin, and the current exploration for oil in the eastern lowlands of Bolivia. These activities have generated topographic and geologic maps, aerial photographs, seismic profiles, satellite images, and collaborative projects between the Bolivian Geological Survey (GEOBOL; Geologic Map Series, 1:100,000 scale) and other organizations. A digital geologic map of the Altiplano and the Cordillera Occidental is available at <http://geo-nsdi.er.usgs.gov/metadata/open-file/95-494/metadata.faq.html>, and the economic resources are discussed in a U.S. Geological Survey and Servicio Geológico de Bolivia (1992) publication with an accompanying geologic map. The Cornell Andes Project (<http://www.geo.cornell.edu/geology/cap/index.html>) and the Deformation Processes in the Andes Project, a collaborative research program of several German universities and institutes, generate and track information on Andean geology. Lamb (2004) has discussed field experiences involved in obtaining these data in *Devil in the Mountain: A Search for the Origin of the Andes*.

In Bolivia, the mountains consist of three morphotectonic units: the Cordillera Occidental, the 250-km-wide Altiplano, and the Cordillera Oriental (Fig. 3), in addition to the undulating eastern slopes of the Cordillera Oriental called the Yungas. Subduction of the Nazca Plate into the Peru-Chile trench has varied from relatively rapid and steeply angled at ca. 35° prior to the Pliocene, generating volcanism, to a slower, lower-angled, flat-slab subduction of ca. 15° after 5 Ma with less volcanism. The angle of subduction also varies spatially along the Andes from steep-slab subduction in northern Peru and Ecuador to shallow flat-slab subduction in southern Peru and Chile. This helps explain the spatial occurrence of volcanic and nonvolcanic zones in the present Andes. As the subducting plate reaches a depth of ca. 200 km, the leading edge becomes molten and the magma reaches the surface as lava through cracks, fissures, and volcanoes. Some volcanic activity still continues. In January 1835, Charles Darwin saw a “great glare of light” from the eruption of Corcovado Volcano in southern Chile and also observed an earthquake at Valdivia, Chile, that elevated the crust 3 m in a matter of seconds (Darwin, 1845: 277). In May 1960, the largest earthquake ever recorded in South America occurred near Concepción with a magnitude of 9.5 (Richter scale). The last eruption of Llaima was on 2 January 2008 (Associated Press, 2008).

In addition to subduction, which accounts for about one fifth of the height of the Andes, another force is compression generated by westward movement away from the Mid-Atlantic Ridge with the western edge of the continent encountering resistance

against the Nazca Plate and where it encounters eastward-directed force from subduction. Compression accounts for approximately four fifths of the height of the central Andes. A third factor is a thinning of the underlying lithosphere, as in the vicinity of Cerro Aconcagua, which produces heating, weakening, and buckling of the crust to exceptionally high elevations. This thinning often involves the sudden detachment of unstable lower lithosphere and results in a punctuated history of surface uplift (Garzione et al., 2008). In other places, crustal thickening is important, for example, beneath the Altiplano where the lithosphere exceeds 100 km, and these differences in thickness contribute to the differential heights along the Andes.

Once substantial heights have been attained, other mechanisms are necessary to sustain the elevations. If compression was the only force operating on the central Andes, it is estimated they would average ca. 2 km in altitude rather than the actual 4 km. Lamb and Davis (2003) have proposed an explanation that involves changes in climate. The rate of slippage of a plate into a subduction zone depends on the amount of eroded sediments brought in by rivers and that act as a lubricant. If these sediments are absent or curtailed through reduced river flow, subduction slows, friction builds up, and high altitudes are maintained. The development of the cold Humboldt Current, sometime after 30 Ma (opening of the Drake Passage), in combination with altitudes attained by the central Andes that were sufficient to cast a rain shadow to the west at ca. 15 Ma, caused aridity along the coast and minimized transport of sediment into the subduction zone. Compression from the westward drift of South America, combined with greater friction, accounts for ca. 300 km of crustal shortening in the central Andes during the past ca. 35 million years (Sobolev & Babeyko, 2005). Comparable explanations for uplift involving climate have been proposed for the southern central Andes (Alonso et al., 2006) and the southern Patagonian Andes (Blisniuk et al., 2006). Isostasy (rebound of the crust from removal of overlying material by erosion) is another factor.

In the Middle Cretaceous, about 100 Ma, the western border of South America in the vicinity of the central Andes comprised swampland and lakes periodically inundated by marine waters but without substantial highlands. This is shown by the horizontal Cretaceous strata, the paucity of eroded terrigenous sediments, and the presence of shallow-water limestone, including lime and mud with great concentrations of dinosaur footprints. Nearby to the west was a volcanic island arc contributing lava and ash to the Cretaceous sediments.

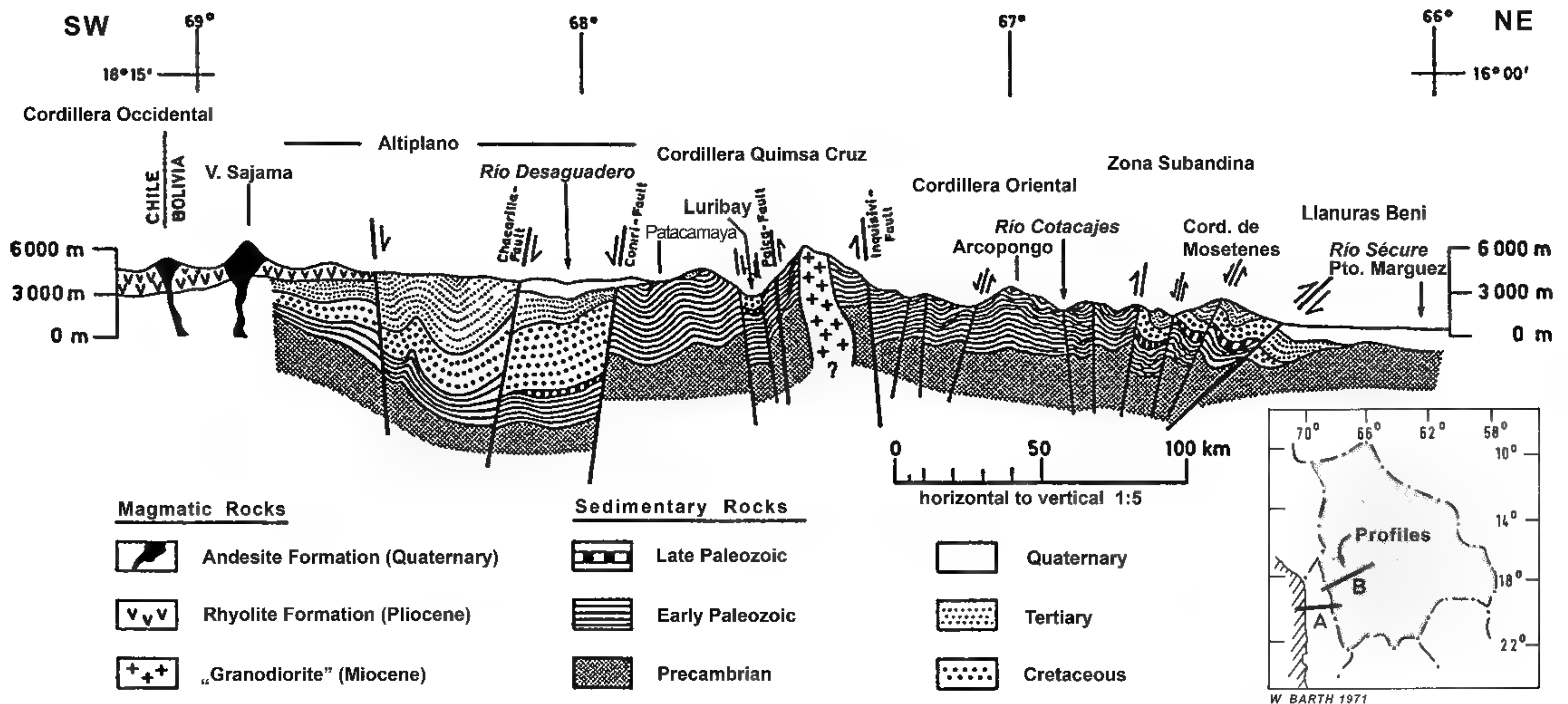

Figure 3. Sectional view of the Bolivian Andes showing approximate elevations, faults, rock types, and ages for the Western Cordillera, Altiplano, and Eastern Cordillera. Note the corrugated topography of the eastern slopes (Yungas) designated Zona Subandina on the figure. From Zeil (1979); used with permission of Borntraeger, Berlin.

Around 40 Ma (Late Eocene), terrigenous sand and silt began covering the swamp, indicating relatively rapid emerging land. One result was deposition of the Potoco Formation that contains a palynoflora of low-altitude terrestrial plants (Horton et al., 2001). Part of the reason for the uplift ca. 40 Ma is that subduction of the Nazca Plate slowed from ca. 15 to 5 cm/yr., possibly due in part to compensation for the intensifying collision of India with Asia at this time (Lamb, 2004: 285). As subduction slowed, sediments cooled and hardened, friction built up, and continuing compression forces resulted in the creation of highlands. This uplift of the central Andes ca. 40 Ma was a biologically important event providing rising uplands where there had been coastal swamps earlier.

By 30 Ma, segments of the line of volcanoes had become appressed to the continental margin, with associated uplift and crustal shortening, notably in the mostly volcanic proto-Cordillera Occidental of southern Peru and Bolivia. The sediments continued to accumulate in the intervening lowlands, which would eventually be elevated as the Bolivian and Peruvian Altiplano. At this time, the Altiplano was a river basin near sea level. Subduction, compression, and appression forces continued, and by ca. 15 Ma (Middle Miocene) approximately half (1500–2000 km) of the present 4000 km average altitude of the central Andes had been attained. Uplift of the Cordillera Oriental also occurred but involved an additional source of compression. As the Brazilian Shield, the original Precambrian craton around which the continent was built, shifted westward subsurface, it underthrust the

Cordillera Oriental. This caused crustal shortening of the Cordillera Oriental of more than 100 km between 30 and 20 Ma, and more than 100 km between 10 Ma and the present, as these mountains rode up and over the western edge of the Brazilian Shield. This contributed to high altitudes and the distinctive corrugated topography of the eastern slopes (Zona Subandina on Fig. 3).

Several paleobotanical studies have contributed to reconstructing the paleoenvironment, vegetation, and uplift history of the central Andes. One is from Pislepampa (17°11'S), 20 km to the northeast of Cochabamba in the Cordillera Oriental of Bolivia at an elevation of 3600 m (Graham et al., 2001). The age of the flora is 6–7 Ma. Among the palynomorphs are spores and pollen grains of *Isoetes* L., *Lycopodium* L., *Cnemidaria* C. Presl, *Cyathea* Sm., *Hymenophyllum* Sm., *Pteris* L., *Danaea* Sm., *Palmae* Juss., and *Cavanillesia* Ruiz & Pav. Megafossils illustrated by Berry (1922) are mostly large and all have entire-margined leaves characteristic of lowland rainforest (bosque amazónico; Killeen et al., 1993). The microfossils also include pollen of *Prumnopitys* Phil. and cf. *Oreopanax* Decne. & Planch., which presently grow together in the cloud forest (bosque húmedo; Fig. 4). The plant fossil evidence indicates deposition near the contact between rainforest and the lower limits of the cloud forest, which is at ca. 1200 m. This implies an uplift of ca. 2400 m since deposition of the Pislepampa flora ca. 6–7 Ma. Other studies on the paleobotany and geology of the central Andes (Gregory-Wodzicki et al., 1998; Gregory-Wodzicki, 2000; Montgomery et al., 2001; Ghosh et al., 2006;



Figure 4. Cloud forest vegetation near Comarapa, Bolivia. The large palmate-leaved plant in the center is *Oreopanax*, and the tall plant to the far right is *Prumnopitys*. The pollen grains are *Oreopanax* (left) and *Prumnopitys/Podocarpus* L'Hér. ex Pers. (right) recovered from the Pislepampa flora (6–7 million years old).

Rowley & Garzzone, 2007) suggest an uplift of one third to half the present altitude after 10 Ma; that is, a rise from ca. 2000 m to the present 4000 m. The highest elevation would be the latest achieved, meaning that páramo habitats are the youngest in the Andean system. The latest cooling ushering in the Pleistocene glaciations began in the Late Pliocene, so the combination of maximum altitudes and globally cooling temperatures date the beginning of páramo vegetation to ca. 3–5 Ma, making it the youngest of the Latin American natural ecosystems and affording opportunities for rapid island-like radiation of mid-altitude species (e.g., *Lupinus* L.; Hughes & Eastwood, 2006). Ribas et al. (2007: 2399) attribute existing diversity in montane lineages generally to events in Earth history, and Andean diversity of *Pionus* parrots specifically to three lineages “transported passively to high elevations by mountain building, and that subsequent diversification within the Andes was driven primarily by Pleistocene climatic oscillations and their large-scale effects on habitat change.”

The establishment of a general chronology for the history of the central Andes makes it possible to address two other questions of biological interest. One question is when did uplift reach a point that it constituted a major vicariant event? This obviously varies with the different biotic lineages, their

ecological parameters, and their distribution potentials, although after the Middle Miocene at ca. 15 Ma an increasing number of species to the east and west of the mountains would find it increasingly difficult to interchange.

Another question is when did altitudes of the central Andes of northern Chile, Bolivia, and Peru reach an elevation that rain shadows began forming to the west and contributing to the formation of the Atacama Desert? The gradual separation of Antarctica from South America through the Drake Passage took place between 50 and 30 Ma (Livermore et al., 2005). This event isolated Antarctica from warm marine waters and contributed to the expansion of glaciers and sea ice. The cold Humboldt Current further cooled at about this time, and winds blowing across the water lost moisture and arrived on the western coast as a dry and desiccating wind. A second factor was the barrier to moisture from the east that also developed in the Middle Miocene at ca. 15 Ma as revealed by arid lacustrine (lake) sediments in the forearc regions of northern Chile (Sáez et al., 1999). The Middle Miocene was an important time in the modernization of the Earth's plant communities because Late Cenozoic cooling had reached a stage when water evaporating from the ocean surface became reduced, with an increase in seasonality and

the spread of grasslands and dry forests (Graham, 1999: chapter 7). In western South America ca. 15 Ma, the combination of dry westerly winds and rain shadow allowed elements pre-adapted to aridity from slope, exposure, and edaphic conditions, as well as from immigration, to coalesce into the beginnings of an ecosystem recognizable as desert.

Among the myriad features of the Andes relevant to the biology of the region is the Bolivian Orocline or "elbow of the Andes" at ca. 18°S. Killeen et al. (2007) suggested that this bend presents a face more at a right angle than other sections to winds coming off the Amazon Basin and augments rainfall on the already wet lower slopes. If so, this may have perpetuated wet conditions during dry intervals of the Late Cenozoic and served as a refugium for rainforest taxa (see discussion in Graham, 2009: chapter 8). Another physical feature of biological interest is the east-facing concave, almost semicircular shape of the Andes toward the Amazon between ca. 8°S and 10°N. This feature traps humidity and further augments wet conditions on the slopes and in the lowlands.

A focus of current environmental and vegetation history studies in the central Andes is on the Quaternary period of the Altiplano. In the northern Altiplano around Lake Titicaca (Baker, 2001a, b; Paduano et al., 2003; Tapia et al., 2003), temperatures were estimated to be 3°C–5°C cooler than at present until 21 thousand years (Kyr) BP (around the late glacial maximum) and the snow line was ca. 500 m below the current 4850 m. Then a warming trend began with higher lake levels and wet conditions until ca. 10 Kyr BP, followed by a mid-Holocene warm dry period (9000–3100 years BP, especially between 7960 and 3100 Kyr BP) when water levels dropped by 100 m; salinity, charcoal, and dust levels increased; and temperatures were an estimated 1°C–3°C warmer than at present. At the Salar de Uyuni on the Altiplano, moisture may have varied with Heinrich events 1 and 2 and with the Younger Dryas cold event between 13 and 11.5 Kyr (Baker et al., 2001a; see below). Lakes started to rise at ca. 4000 years BP and reached modern levels at ca. 1500 years BP (Abbott et al., 1997a, b).

In the southern Altiplano, at the upper limits of the Atacama Desert, Placzek et al. (2006, 2009) include 53 new uranium-thorium (U-Th) and 87 new ¹⁴C dates that provide a more precise chronology for climate change. The basins or salars are now mostly dry, and the region is a barren and rocky landscape of lava, shifting dunes, and some of the largest salt flats on Earth. However, between 120 and 98 Kyr BP there were lakes 80 m deep on the Altiplano. These intermittently shallowed between 98 and 18.1 Kyr BP, then at 18.1–14.1 Kyr BP, a lake ca. 140 m deep

developed that was the largest and deepest of the past 120 Kyr (Placzek et al., 2006). Subsequently, there were smaller changes on a finer timescale that reflect climatic fluctuations of the Holocene. The moister intervals and higher lake levels correspond to periods of human occupation on the Altiplano, whereas during the driest intervals (e.g., 9500–4500 years BP) the sites were abandoned (Grosjean, 1994; Grosjean & Núñez A., 1994; Núñez et al., 2002; Grosjean et al., 2005).

THE NORTHERN ANDES

The northern Andes extend from 5°S at about the Amotape Cross at 2°S to the Oca, Romeral, and other fault systems across northern South America at the contact with the Caribbean Plate at ca. 12°N (Fig. 5). The Andes branch in southwestern Colombia to form the Cordilleras Occidental, Central, and Oriental (Orme, 2007a: fig. 1.5). The Cordillera Oriental branches again into the western Sierra Nevada de Santa Marta and Sierra de Perijá and the eastern Cordillera de Mérida, the two branches enclosing Lake Maracaibo. The latter is a region of major petroleum reserves and, like the mineral deposits of the Altiplano, it has been the impetus for numerous geological, paleoenvironmental, and vegetational history studies (Germeraad et al., 1968; Jaramillo & Dilcher, 2001). The Andes continue along the northern coast as the Caribbean Mountain system with portions submerged to form the Netherlands Antilles and other islands of the southern Caribbean Sea.

The northern Andes are as complex as the central Andes, but their uplift and other features are due to a different combination of tectonic forces (Kroonenberg et al., 1990). In the Late Cretaceous, there was some restriction between the Amazon Basin and the Pacific Ocean, but passages existed through which the proto-Amazon and proto-Orinoco rivers drained into the Pacific. During the Paleocene, marine sediments were still being deposited at sites in the present northern central Andes (Sempre et al., 1997). By the Middle Miocene (ca. 15 Ma), the mountains had reached sufficient height so that there was substantial warping, ridging, and some tilting of the Amazon Basin eastward, and the rivers started to flow toward the Atlantic Ocean. Evidence for the timing of this event comes from varied sources. Van der Hammen (1952), Hoorn (1994a, b, 2006), and Hoorn et al. (1995) note a change along the Solimões River from west-dipping cross-bedding (Mariñame unit) to east-dipping cross-bedding (Solimões and Pebas formations) between the Early and Late Miocene. A submarine fan first appears at the mouth of the Amazon River in the

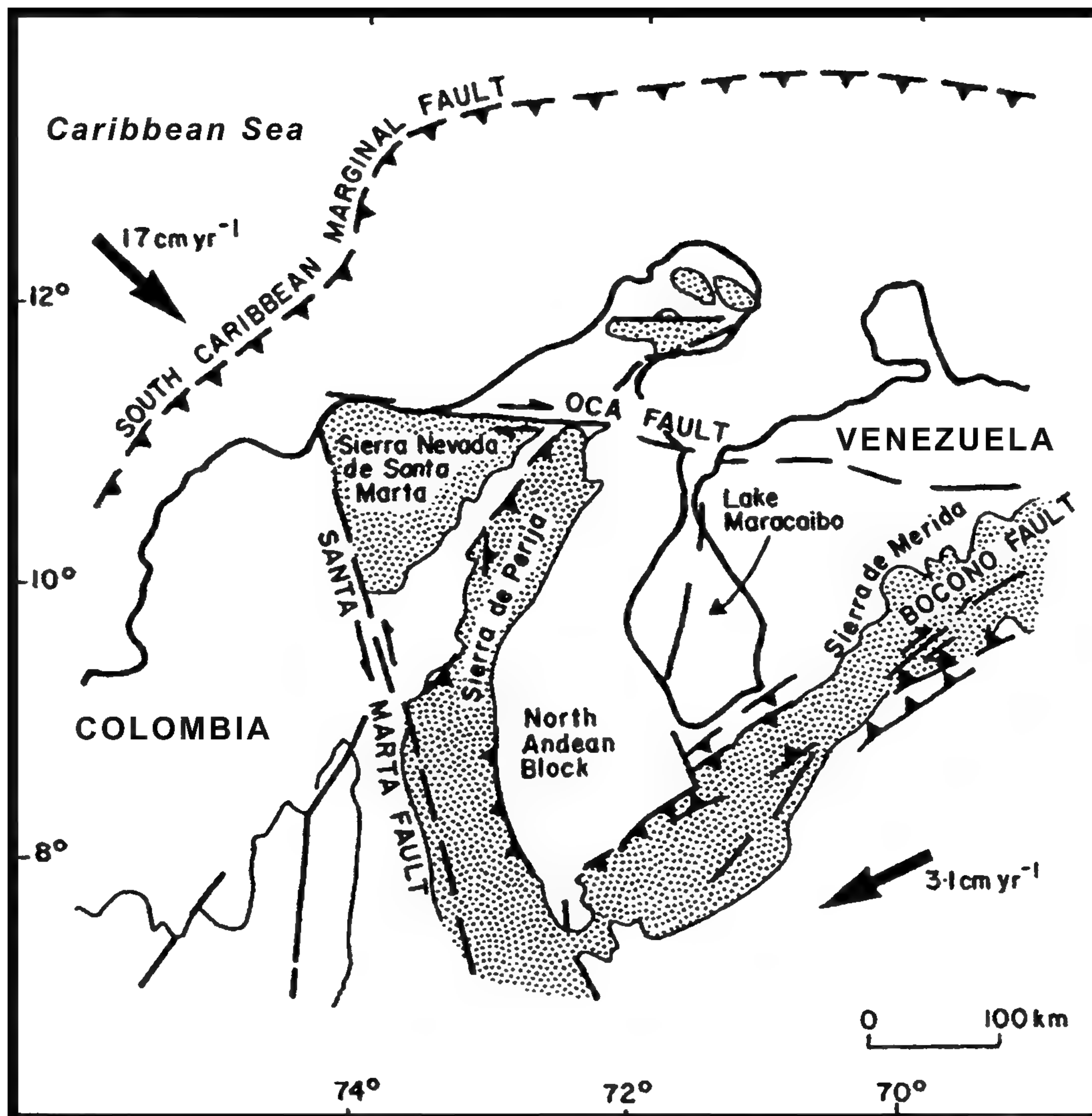

Figure 5. Portion of the North Andean Block in eastern Colombia and western Venezuela, including the Santa Marta Block and the Perijá and Merida Andes, with principal structural features. From Clapperton (1993); used with permission of Elsevier, Amsterdam.

Middle Miocene, and delta deposits of the same age begin to form along the coasts of the Guianas.

The tectonic factors include subduction from the Nazca Plate beneath northwestern South America at a present rate of 3–6 cm/yr., with a particularly complicated section at the junction with Cocos Plate. There is compression from the westward movement of the continent against the plate, shearing along the northern coast as South America moves westward relative to the Caribbean Plate, and appression that has brought volcanic island arcs and terranes onto the northwestern coast. One of these is the Cordillera Occidental, which is composed of accreted terranes of

volcanic origin, while the Cordillera Oriental and Cordillera Central are primarily nonvolcanic mountains. The proto-Cordillera Occidental was accreted onto the coast in the Late Cretaceous (Winsemann, 1994) as indicated by a line of ophiolites (oceanic basalts caught between suturing plates). By the Middle to Late Miocene, the northern Andes were about half their present average elevation, which is slightly later than the southern Andes. Uplift of the Cordillera Oriental to its present height occurred between 6 and 3 Ma, and it is estimated that the Sierra de Perijá has risen 11–16 mm/yr. since the Late Pliocene (Clapperton, 1993).

The rise of megamountain systems has many effects on the immediately surrounding region. In the Late Miocene, uplift of the Cordillera Oriental of the northern Andes blocked the flow of the Maracaibo River and formed Lake Maracaibo. This event created conditions favorable to the formation of extensive oil reserves in the basin where the need for accurate stratigraphic correlation, zonation, and environmental reconstruction resulted in extensive palynological studies by the Bataafse Internationale Petroleum Maatschappij (later Shell Oil), and the publication of the first extensive survey of Tertiary vegetation from the tropical areas of South America (Colombia, Venezuela, Trinidad, the Guianas; Germeraad et al., 1968). The work is still of systematic, biogeographic, and paleoecologic value, because microfossils were identified according to their biological affinities rather than by an artificial stratigraphic nomenclature.

Paleodrainage patterns in the Amazon Basin, and changes in these patterns induced in large measure by the rise of the Andes Mountains, are important because they fragment the biota into geographically and thereby reproductively isolated populations. Deltaic deposits allow tracing the meandering course of rivers through long intervals of time. In the Middle Eocene, the Misoa paleodelta identifies a large river flowing north into the Maracaibo Basin that drained the Cordillera Central and the Guyana Highlands. Uplift of the mountains shifted delta formation southward as shown by the Late Eocene to Oligocene Carbonera Formation in the Llanos Orientales region of Colombia and Venezuela. By the Middle to Early Miocene, there was a delta in the northwestern part of the Falcón Basin to the east of Maracaibo, and in the late part of the Middle Miocene it had shifted to its present position in the Venezuelan Basin south of Trinidad and Tobago (Díaz de Gamero, 1996). These record the positioning of the Amazon and Orinoco rivers between the Late Eocene and the Middle Miocene, and similar changes affected all the rivers and tributaries in the Amazon and Orinoco basins during the Tertiary.

Alfred Russell Wallace (1849, 1876) used these river drainage patterns to develop his riverine hypothesis that maintained the past and present distribution of species in the Amazon Basin has been strongly influenced by river barriers, and this has generally proven to be true, especially for mammals such as the tamarinds. For other animals, such as some rodents, other factors were involved, and these were the result of the uplift of the northern Andes. Patton et al. (1994; Patton & Da Silva, 1998, 2005) found that some populations, although morphologically similar, differed in having distinct mitochondrial DNA (mtDNA) signatures. The populations were not

segregated on different sides of the most obvious barrier, the Juruá River, but rather between the upper reaches and the mouth of the river. Patton (quoted from Morell, 1996: 1497) noted that "What is really striking ... is that all 11 [of the 17 species] are separated at almost the same geographical point on the river, although there is nothing remarkable about the spot—no bend, no hill, no valley." The demarcation is at the ancient Iquitos Arch, which is one of several arches formed during mountain uplift and that subdivided the basin into a number of subunits. The basin floor is now covered in places by more than 4000 m of eroded sediment that obscures the arches, but they were once effective barriers to the interchange of some groups of organisms, and this history still resides in their molecular signature. The arches also affect the distribution of sediments and, thereby, edaphic patterns in the Amazon Basin (Dunne et al., 1998).

Another effect of Andean uplift, combined with sea-level changes and subsidence of the basin from sediment accumulation, was the periodic drainage and inundation of the basin by marine or brackish water (Hoorn et al., 1995), primarily from the Caribbean Sea through the Maracaibo Basin. Fish faunas and mangroves are good indicators of the time and extent of the flooding when the biota are fragmented and reunited. The ichthyofauna reveals several such flooding events in the interior, persisting until the Late Miocene, as well as periods of deeper or shallower, and possibly torrential waters (Monsch, 1998). The Amazon Basin includes the greatest number of freshwater fish species in the world, and Lovejoy et al. (1998), on the basis of the molecular phylogeny of stingrays, believe that this diversity resulted from the repeated fragmentation and reassembly of populations through intervening brackish or salt water. Volcanic ash deposits in eastern lowland Peru contain paleofaunas from 9.01 Ma and 3.12 Ma (Campbell et al., 2001), and the latter date marks the last marine incursion around the margins of the basin.

In other mountainous volcanic settings, there is evidence of the impact of local orogenic history on speciation patterns. On Isla Isabela in the Galápagos Islands, five taxa of the large tortoise occur, one on each of the five volcanoes of the island. *Geochelone nigra vandenburghi* on Alcedo Volcano has considerably less matrilineal diversity in its mtDNA. Although all the volcanoes are about the same age (ca. 500,000 years), Alcedo Volcano last erupted ca. 100,000 years ago. The suggestion is that the event drastically reduced the population diversity from which this particular lineage was derived (Beheregaray et al., 2003). Similar reductions may have occurred among other slow-dispersing organisms isolated in mid- to

Table 1. Glacial/climatic events first discovered in the Northern Hemisphere and now recognized in South America.¹

Location	Glacial/climatic event	Reference
Venezuela (9°N–10°N)	Younger Dryas, mid-Holocene warm/dry period, Little Ice Age	Haug et al., 2001
Colombia (4°N–5°N)	Younger Dryas	Thouret et al., 1996; van der Hammen & Hooghiemstra, 1995
Brazil (3°N–4°N)	Younger Dryas, Heinrich and Dansgaard-Oeschger events, Little Ice Age	Jennerjahn et al., 2004; Cohen et al., 2005
Ecuador (3°S–4°S)	Younger Dryas	Osborn et al., 1995; Heine & Heine, 1996; Clapperton et al., 1997
Peru (8°S)	mid-Holocene warm/dry period, Little Ice Age	Osborn et al., 1995
Bolivia (15°S)	Younger Dryas, mid-Holocene warm/dry period, Heinrich events 1 and 2	Osborn et al., 1995; Abbott et al., 1997a, b, 2000
Chile (Lake District; approximately 30°S–42°S)	Younger Dryas, Heinrich events	Lowell et al., 1995
Southern Argentina–Chile (Patagonia; 45°S)	mid-Holocene warm/dry period, Younger Dryas, Little Ice Age	Mancini et al., 2005

¹ Arrangement is from north (Venezuela, 9°N–10°N) to south (southern Argentina–Chile [Patagonia], 45°S). Evidence for the Younger Dryas in the tropical Andes is considered equivocal by Rodbell and Seltzer (2000) and Seltzer (2007).

higher-elevation habitats along the volcanically active Andes where comparable studies could be made.

Within the mountains, there are many basins now filled with eroded sediments. The high plain of Bogotá is the floor of a drained lake. The Bogotá Basin formed ca. 6 Ma when the Cordillera Oriental was beginning a period of major uplift. It was raised to its present altitude of 2550 m between 4 and 3 Ma, with almost continuous sedimentation since then. The Bogotá Basin has been the site of important paleoenvironmental and vegetational history studies beginning with those of van der Hammen (e.g., van der Hammen et al., 1973) and continuing with those of Hooghiemstra (1984) and Hooghiemstra et al. (2006). Among the results has been the early recognition of downward shifts in high Andean vegetation during cold intervals that were suspected to have affected the lowland Neotropical rainforest. Later studies have shown this to be true (e.g., Hooghiemstra & van der Hammen, 1998; van der Hammen & Hooghiemstra, 2000). Another result was the demonstration of climatic changes and vegetation responses throughout the entire 3.5 million year interval represented by the basin sediments. Some of these correlate with regional to global events elsewhere (e.g., the Younger Dryas; see below).

Quaternary climatic and vegetation changes throughout the Andean chain are important for interpreting the regional vegetation history, but they have broader implications for environmental changes throughout South America. Many of the temperature and precipitation patterns of the Quaternary were initially documented in the northern latitudes and especially around the North Atlantic Ocean. In addition to the longer-term fluctuations of 100,000,

41,000, and 23,000 years of the Milankovitch variations (with subcycles), there were warm and cold intervals on a much finer scale. These intervals include the cold reversal during the terminal Pleistocene/Holocene called the Younger Dryas (13,000–11,500 years BP), the Medieval Warm Period (800–1200 CE), and the Little Ice Age (1300–1850 CE). Heinrich events are cold periods of a few to several thousand years' duration, while Dansgaard-Oeschger (D-O) events occur on a scale of a few thousand to several hundred years. These events involve fluctuations in the thermohaline (conveyor belt) transport of heat in the form of warm surface waters from the tropics to the North Atlantic; cooling of these waters; and transport back to the tropics as cold Atlantic deep water, where it warms and returns again northward.

When results of the Climate: Long-range Investigation, Mapping, and Prediction project (CLIMAP, 1976, 1981, 1984) and the Cooperative Holocene Mapping Project (COHMAP, 1988) were published, they suggested that while temperatures were colder by 12°C–14°C in the high northern latitudes at the Last Glacial Maximum, equatorial temperatures remained the same or cooled by a maximum of ca. 2°C. The work previously cited for the High Andes was difficult to reconcile with the climatic and the implied vegetation stasis of the tropics, but definitive evidence was not yet available. Then Grimm et al. (1993; Watts & Hansen, 1994) found fluctuations in pine pollen that corresponded with Heinrich events 1 to 5 in bogs at Lake Tulane, Florida (28°N). Guilderson et al. (1994) proposed a lowering of 5°C at the Last Glacial Maximum based on strontium:calcium ratios from corals on Barbados at a latitude ca. 12°N, and several

studies now document a similar cooling for the Brazilian lowlands (Stute et al., 1995; Webb et al., 1997; Aeschbach-Hertig et al., 2000). There is now paleobotanical and independent geologic evidence for rapid temperature and precipitation changes from several places in the tropics (Table 1; see Graham, 2009 for additional references).

One reason these kinds of evidence are significant is that for a long time, through about the 1960s, it was thought that tropical climates and the tropical biota were stable and unchanging (e.g., Corner, 1958). This seemed to be supported by the CLIMAP (1976, 1981, 1984) and COHMAP (1988) results of the 1970s and 1980s. In turn, this could be used to rationalize the view that the tropical biota could be impacted with impunity and would recover because they had endured unchanged for millions of years. This was suspected not to be true (see reviews, e.g., by Vuilleumier, 1971), and a study of the mid-Pliocene Paraje Solo microfossil floras in southern Veracruz, Mexico, provided direct paleobotanical evidence that in an area where rainforest is the dominant vegetation today, it was not present in the recent geologic past (Graham, 1976a, b). Subsequent studies have extended this finding to other communities and other locations, so that today all ecosystems throughout the equatorial latitudes, from lowland rainforest to the páramo of the High Andes, and from Brazil, Colombia, and Venezuela to Argentina and Chile, are recognized as delicately balanced assemblages that have taken millions of years to develop, have had a dynamic past on all timescales, and deserve the conservation and sustainable development efforts that fact alone implies.

Literature Cited

- Abbott, M. B., M. W. Binford, M. Brenner & K. R. Kelts. 1997a. A 3500 ^{14}C yr high-resolution record of water-level changes in Lake Titicaca, Bolivia/Peru. *Quatern. Res.* 47: 169–180.
- , G. O. Seltzer, K. R. Kelts & J. Southon. 1997b. Holocene paleohydrology of the tropical Andes from lake records. *Quatern. Res.* 47: 70–80.
- , B. B. Wolfe, R. Aravena, A. P. Wolfe & G. O. Seltzer. 2000. Holocene hydrological reconstructions from stable isotopes and paleolimnology, Cordillera Real, Bolivia. *Quatern. Sci. Rev.* 19: 1801–1820.
- Aeschbach-Hertig, W., F. Peeters, U. Beyerle & R. Kipfer. 2000. Paleotemperature reconstruction from noble gases in ground water taking into account equilibration with entrapped air. *Nature* 405: 1040–1043.
- Alonso, R. N., B. Bookhagen, B. Carrapa, I. Coutand, M. Haschke, G. E. Hilley, L. Schoenbohm, E. R. Sobel, M. R. Strecker, M. H. Trauth & A. Villanueva. 2006. Tectonics, climate, and landscape evolution of the Southern Central Andes: The Argentine Puna Plateau and adjacent regions between 22 and 30° S. Pp. 265–283 in O. Oncken, G. Chong, G. Franz, P. Giese, H.-J. Götze, V. A. Ramos, M. R. Strecker & Peter Wigger (editors). *The Andes: Active Subduction Orogeny*. *Frontiers in Earth Sciences*. Springer Verlag, Berlin.
- Associated Press. 2008. Villagers flee volcano eruption in Chile. *The Guardian* [online edition]. 2 January 2008. <<http://www.guardian.co.uk/world/2008/jan/02/naturaldisasters.chile>>, accessed 13 July 2009.
- Baker, P. A., C. A. Rigsby, G. O. Seltzer, S. C. Fritz, T. K. Lowenstein, N. P. Bacher & C. Veliz. 2001a. Tropical climate changes at millennial and orbital timescales on the Bolivian Altiplano. *Nature* 409: 698–701.
- , G. O. Seltzer, S. C. Fritz, R. B. Dunbar, M. J. Grove, P. M. Tapia, S. L. Cross, H. D. Rowe & J. P. Broda. 2001b. The history of South American tropical precipitation for the past 25,000 years. *Science* 291: 640–643.
- Beheregaray, L. B., C. Ciofi, D. Geist, J. P. Gibbs, A. Caccone & J. R. Powell. 2003. Genes record a prehistoric volcano eruption in the Galápagos. *Science* 302: 75.
- Berry, E. W. 1922. *Contributions to the Paleobotany of Peru, Bolivia and Chile*. Johns Hopkins University Studies in Geology, No. 4. The Johns Hopkins Press, Baltimore.
- Blisniuk, P. M., L. A. Stern, C. P. Chamberlain, P. K. Zeitler, V. A. Ramos, E. R. Sobel, M. Haschke, M. R. Strecker & F. Warkus. 2006. Links between mountain uplift, climate, and surface processes in the southern Patagonian Andes. Pp. 429–440 in O. Oncken, G. Chong, G. Franz, P. Giese, H.-J. Götze, V. A. Ramos, M. R. Strecker & P. Wigger (editors). *The Andes: Active Subduction Orogeny*. *Frontiers in Earth Sciences*. Springer Verlag, Berlin.
- Campbell, K. E., Jr., M. Heizler, C. D. Frailey, L. Romero-Pittman & D. R. Prothero. 2001. Upper Cenozoic chronostratigraphy of the southwestern Amazon Basin. *Geology* 29: 595–598.
- Clapperton, C. 1993. *Quaternary Geology and Geomorphology of South America*. Elsevier, Amsterdam.
- , J. D. Clayton, D. I. Benn, C. J. Marden & J. Argollo. 1997. Late Quaternary glacier advances and palaeolake highstands in the Bolivian Altiplano. *Quatern. Int.* 38/39: 49–59.
- CLIMAP Project Members. 1976. The surface of the ice-age Earth. *Science* 191: 1131–1137.
- . 1981. Seasonal reconstruction of the Earth's surface at the last glacial maximum. *Map Chart Series MC-36*. Geological Society of America, Boulder.
- . 1984. The last interglacial ocean. *Quatern. Res.* 21: 123–224.
- Cohen, M. C. L., H. Behling & R. J. Lara. 2005. Amazonian mangrove dynamics during the last millennium: The relative sea-level and the Little Ice Age. *Rev. Palaeobot. Palynol.* 136: 93–108.
- COHMAP Members. 1988. Climatic changes of the last 18,000 years: Observations and model simulations. *Science* 241: 1043–1052.
- Cordani, U. G., E. J. Milani, A. T. Filho & D. A. Campos (editors). 2000. *Tectonic Evolution of South America*. 31st International Geological Congress, Rio de Janeiro, 6–17 August 2000. Geological Society of America, Boulder.
- Corner, E. J. H. 1958. The evolution of tropical forest. Pp. 34–46 in J. Huxley, A. C. Hardy & E. B. Ford (editors). *Evolution as a Process*. Allen and Unwin, London.
- Coronato, A., M. Salemme & J. Rabassa. 1999. Palaeoenvironmental conditions during the early peopling of southernmost South America (Late Glacial–Early Holocene, 14–8 ka BP). *Quatern. Int.* 53/54: 77–92.
- Darwin, C. 1845. *Voyage of the Beagle* [reprint 1997]. Wordsworth Editions, Ware, Hertfordshire, United Kingdom.

- Dewey, J. F. & J. M. Bird. 1970. Mountain belts and the new global tectonics. *J. Geophys. Res.* 75: 2625–2647.
- Díaz de Gamero, M. L. 1996. The changing course of the Orinoco River during the Neogene: A review. *Palaeogeogr. Palaeoclimatol. Palaeoecol.* 123: 385–402.
- Dunne, T., L. A. K. Mertes, R. H. Meade, J. E. Richey & B. R. Fosberg. 1998. Exchanges of sediment between the flood plain and channel of the Amazon River in Brazil. *Bull. Geol. Soc. Amer.* 110: 450–467.
- Gansser, A. 1973. Facts and theories on the Andes. *J. Geol. Soc.* 129: 93–131.
- Garzzone, C. N., G. D. Hoke, J. C. Libarkin, S. Withers, B. MacFadden, J. Eiler, P. Ghosh & A. Mulch. 2008. Rise of the Andes. *Science* 320: 1304–1307.
- Germeraad, J. H., C. A. Hopping & J. Muller. 1968. Palynology of Tertiary sediments from tropical areas. *Rev. Palaeobot. Palynol.* 6: 189–348.
- Ghosh, P., C. N. Garzzone & J. M. Eiler. 2006. Rapid uplift of the Altiplano revealed through ^{13}C - ^{18}O bonds in paleosol carbonates. *Science* 311: 511–515.
- Giles, J. 2005. Geologists call time on dating dispute. *Nature* 435: 865.
- Graham, A. 1976a. Studies in neotropical paleobotany. II. The Miocene communities of Veracruz, Mexico. *Ann. Missouri Bot. Gard.* 63: 787–842.
- . 1976b. Late Cenozoic evolution of tropical lowland vegetation in Veracruz, Mexico. *Evolution* 29: 723–735.
- . 1999. Late Cretaceous and Cenozoic History of North American Vegetation. Oxford University Press, Oxford.
- . 2009. Late Cretaceous and Cenozoic History of Latin American Vegetation and Terrestrial Environments. Missouri Botanical Garden Press, St. Louis. In press.
- , K. M. Gregory-Wodzicki & K. L. Wright. 2001. Studies in neotropical paleobotany. XV. A Mio-Pliocene palynoflora from the Eastern Cordillera, Bolivia: Implications for the uplift history of the Central Andes. *Amer. J. Bot.* 88: 1545–1557.
- Gregory-Wodzicki, K. M. 2000. Relationships between leaf morphology and climate, Bolivia: Implications for estimating paleoclimate from fossil floras. *Paleobiology* 26: 668–688.
- , W. C. McIntosh & K. Velásquez. 1998. Climate and tectonic implications of the late Miocene Jakokkota flora, Bolivian Altiplano. *J. S. Amer. Earth Sci.* 11: 533–560.
- Grimm, E., G. L. Jacobson Jr., W. A. Watts, B. C. S. Hansen & K. A. Maasch. 1993. A 50,000-year record of climate oscillations from Florida and its temporal correlation with Heinrich events. *Science* 261: 198–200.
- Grosjean, M. 1994. Paleohydrology of the Laguna Lejía (north Chilean Altiplano) and climatic implications for late-glacial times. *Palaeogeogr. Palaeoclimatol. Palaeoecol.* 109: 89–100.
- & L. Núñez A. 1994. Late glacial, early and middle Holocene environments, human occupation, and resource use in the Atacama (northern Chile). *Geoarchaeology* 9: 271–286.
- , ——— & I. Cartajena. 2005. Palaeoindian occupation of the Atacama Desert, northern Chile. *J. Quatern. Sci.* 20: 643–653.
- Guilderson, T. P., R. G. Fairbanks & J. L. Rubenstone. 1994. Tropical temperature variations since 20,000 years ago: Modulating interhemispheric climate change. *Science* 263: 663–665.
- Haug, G. H., K. A. Hughen, D. M. Sigman, L. C. Peterson & U. Röhl. 2001. Southward migration of the Intertropical Convergence Zone through the Holocene. *Science* 293: 1304–1308.
- Heine, K. & J. T. Heine. 1996. Late glacial climate fluctuations in Ecuador: Glacial retreat during Younger Dryas time. *Arctic Alpine Res.* 28: 496–501.
- Heusser, C. J. 2003. Ice Age Southern Andes: A Chronicle of Paleocological Events. Elsevier, Amsterdam.
- Hooghiemstra, H. 1984. Vegetational and climatic history of the High Plain of Bogotá, Colombia: A continuous record of the last 3.5 million years. *The Quaternary of Colombia* 10: 1–368. [Reprinted from *Dissertationes Botanicae*, Band 79, J. Cramer, Vaduz, Germany].
- , V. M. Wijnga & A. M. Cleef. 2006. The paleobotanical record of Colombia: Implications for biogeography and biodiversity. *Ann. Missouri Bot. Gard.* 93: 297–324.
- & T. H. van der Hammen. 1998. Neogene and Quaternary development of the neotropical rain forest: The forest refugia hypothesis, and a literature overview. *Earth-Sci. Rev.* 44: 147–183.
- Hoorn, C. 1994a. Fluvial palaeoenvironments in the intracratonic Amazonas Basin (early Miocene-early middle Miocene, Colombia). *Palaeogeogr. Palaeoclimatol. Palaeoecol.* 109: 1–54.
- . 1994b. An environmental reconstruction of the palaeo-Amazon River system (middle-late Miocene, NW Amazonia). *Palaeogeogr. Palaeoclimatol. Palaeoecol.* 112: 187–238.
- . 2006. The birth of the mighty Amazon. *Sci. Am.* May: 52–59.
- , J. Guerrero, G. A. Sarmiento & M. A. Lorente. 1995. Andean tectonics as a cause for changing drainage patterns in Miocene South America. *Geology* 23: 237–240.
- Horton, B. K., B. A. Hampton & G. L. Waanders. 2001. Paleogene synorogenic sedimentation in the Altiplano Plateau and implications for initial mountain building in the Central Andes. *Bull. Geol. Soc. Amer.* 113: 1387–1400.
- Hughes, C. & R. Eastwood. 2006. Island radiation on a continental scale: Exceptional rates of plant diversification after uplift of the Andes. *Proc. Natl. Acad. U.S.A.* 103: 10334–10339.
- Jaramillo, C. A. & D. L. Dilcher. 2001. Middle Paleogene palynology of central Colombia, South America: A study of pollen and spores from tropical latitudes. *Palaeontographica, Abt. B, Paläophytol.* 258: 87–213.
- Jennerjahn, T. C., V. Ittekkot, H. W. Arz, H. Behling, J. Pätzold & G. Wefer. Asynchronous terrestrial and marine signals of climate change during Heinrich events. *Science* 306: 2236–2239.
- Killeen, T. J., E. García E. & S. G. Beck (editors). 1993. *Guía de Árboles de Bolivia*. Herbario Nacional de Bolivia, La Paz; Missouri Botanical Garden, St. Louis.
- , M. Douglas, T. Consiglio, P. M. Jørgensen & J. Mejía. 2007. Dry spots and wet spots in the Andean hotspot. *J. Biogeogr.* 34: 1357–1373.
- Körner, C. 2007. The use of ‘altitude’ in ecological research. *Trends Ecol. Evol.* 22: 569–574.
- Kroonenberg, S. B., J. G. M. Bakker & M. Van der Wiel. 1990. Late Cenozoic uplift and paleogeography of the Colombian Andes: Constraints on the development of high-Andean biota. *Geol. & Mijnb.* 69: 279–290.
- Lamb, S. 2004. *Devil in the Mountain: A Search for the Origin of the Andes*. Princeton University Press, Princeton, New Jersey.
- & P. Davis. 2003. Cenozoic climate change as a possible cause for the rise of the Andes. *Nature* 425: 792–797.

- Livermore, R., A. Nankivell, G. Eagles & P. Morris. 2005. Paleogene opening of Drake Passage. *Earth Planet. Sci. Lett.* 236: 459–470.
- Lovejoy, N. R., E. Bermingham & A. P. Martin. 1998. Marine incursion into South America. *Nature* 396: 421–422.
- Lowell, T., C. J. Heusser, B. G. Andersen, I. Moreno, A. Hausser, L. E. Heusser, C. Schluchter, D. R. Merchant & G. H. Denton. 1995. Interhemispheric correlation of late Pleistocene glacial events. *Science* 269: 1541–1549.
- Mancini, M. V., M. M. Paez, A. R. Prieto, S. Stutz, M. Tonello & I. Vilanova. 2005. Mid-Holocene climatic variability reconstruction from pollen records (32°–52°S, Argentina). *Quatern. Int.* 132: 47–59.
- Mercer, J. H., R. J. Fleck, E. A. Mankinen & W. Sander. 1975. Southern Patagonia: Glacial events between 4 m.y. and 1 m.y. ago. Pp. 223–230 in R. P. Suggate & M. M. Cresswell (editors). *Quaternary Studies*. Royal Society of New Zealand, Wellington.
- Miotti, L. & M. Salemme. 1999. Biodiversity, taxonomic richness and specialists-generalists during late Pleistocene/early Holocene times in Pampa and Patagonia (Argentina, southern South America). *Quatern. Int.* 53/54: 53–68.
- Monsch, K. A. 1998. Miocene fish faunas from the north-western Amazonian basin (Colombia, Peru, Brazil), with evidence of marine incursions. *Palaeogeogr. Palaeoclimatol. Palaeoecol.* 143: 31–50.
- Montgomery, D. R., G. Balco & S. D. Willett. 2001. Climate, tectonics, and the morphology of the Andes. *Geology* 29: 579–582.
- Moore, E. & R. J. Twiss. 1995. *Tectonics*. W. H. Freeman, New York.
- Morell, V. 1996. Amazonian diversity: A river doesn't run through it. *Science* 273: 1496–1497.
- Núñez, L., M. Grosjean & I. Cartajena. 2002. Human occupations and climate change in the Puna de Atacama, Chile. *Science* 298: 821–824.
- Oncken, O., G. Chong, G. Franz, P. Giese, H.-J. Götze, V. A. Ramos, M. R. Strecker & P. Wigger (editors). 2006. *The Andes: Active Subduction Orogeny*. *Frontiers in Earth Sciences*. Springer Verlag, Berlin.
- Orme, A. R. 2007a. The tectonic framework of South America. Pp. 3–22 in T. T. Veblen, K. R. Young & A. R. Orme (editors). *The Physical Geography of South America*. Oxford University Press, Oxford.
- . 2007b. Tectonism, climate, and landscape change. Pp. 23–44 in T. T. Veblen, K. R. Young & A. R. Orme (editors). *The Physical Geography of South America*. Oxford University Press, Oxford.
- Osborn, G., C. Chalmers, R. T. Davis, M. A. Reasoner, D. T. Rodbell, G. O. Seltzer & G. Zielinski. 1995. Potential glacial evidence for the Younger Dryas event in the Cordillera of North and South America. *Quatern. Sci. Rev.* 14: 823–832.
- Paduano, G. M., M. B. Bush, P. A. Baker, S. C. Fritz & G. O. Seltzer. 2003. A vegetation and fire history of Lake Titicaca since the Last Glacial Maximum. *Palaeogeogr. Palaeoclimatol. Palaeoecol.* 194: 259–279.
- Patton, J. L. & M. N. F. Da Silva. 1998. Rivers, refuges, and ridges: The geography of speciation of Amazonian mammals. Pp. 202–213 in D. Howard & S. H. Berlocher (editors). *Endless Forms: Species and Speciation*. Oxford University Press, Oxford.
- & ———. 2005. The history of Amazonian mammals: Mechanisms and timing of diversification. Pp. 107–126 in E. Bermingham, C. W. Dick & C. Moritz (editors). *Tropical Rainforests: Past, Present, and Future*. University of Chicago Press, Chicago.
- , ——— & J. R. Malcolm. 1994. Gene genealogy and differentiation among arboreal spiny rats (Rodentia: Echimyidae) of the Amazon Basin: A test of the riverine barrier hypothesis. *Evolution* 48: 1314–1323.
- Placzek, C., J. Quade & P. J. Patchett. 2006. Geochronology and stratigraphy of late Pleistocene lake cycles on the southern Bolivian Altiplano: Implications for causes of tropical climate change. *Bull. Geol. Soc. Amer.* 118: 515–532.
- , ———, J. L. Betancourt, P. J. Patchett, J. A. Rech, C. Latorre, A. Matmon, C. Holmgren & N. B. English. 2009. Climate in the dry central Andes over geologic, millennial, and interannual timescales. *Ann. Missouri Bot. Gard.* 96: 386–397.
- Ramos, V. A. & A. Aleman. 2000. Tectonic evolution of the Andes. Pp. 635–685 in U. G. Cordani, E. J. Milani, A. T. Filho & D. A. Campos (editors). *Tectonic Evolution of South America*. 31st International Geological Congress, Rio de Janeiro, 6–17 August 2000. Geological Society of America, Boulder.
- Ribas, C. C., R. G. Moyle, C. Y. Miyaki & J. Cracraft. 2007. The assembly of montane biotas: Linking Andean tectonics and climatic oscillations to independent regimes of diversification in *Pionus* parrots. *Proc. Roy. Soc. London, Ser. B, Biol. Sci.* 274: 2399–2408.
- Rodbell, D. T. & G. O. Seltzer. 2000. Rapid ice margin fluctuations during the Younger Dryas in the tropical Andes. *Quatern. Res.* 54: 328–338.
- Rowley, D. B. & C. N. Garzione. 2007. Stable isotope-based paleoaltimetry. *Annual Rev. Earth Planet. Sci.* 35: 463–508.
- Sáez, A., L. Cabrera, A. Jensen & G. Chong. 1999. Late Neogene lacustrine record and palaeogeography in the Quillagua-Llamara Basin, central Andean fore-arc (northern Chile). *Palaeogeogr. Palaeoclimatol. Palaeoecol.* 151: 5–37.
- Seltzer, G. O. 2007. Late Quaternary glaciation of the tropical Andes. Pp. 60–75 in T. T. Veblen, K. R. Young & A. R. Orme (editors). *The Physical Geography of South America*. Oxford University Press, Oxford.
- Sempre, T., R. F. Butler, D. R. Richards, L. G. Marshall, W. Sharp & C. C. Swisher III. 1997. Stratigraphy and chronology of Upper Cretaceous–lower Paleocene strata in Bolivia and northwest Argentina. *Bull. Geol. Soc. Amer.* 109: 709–727.
- Sobolev, S. V. & A. Y. Babeyko. 2005. What drives orogeny in the Andes? *Geology* 33: 617–620.
- Stute, M., M. Forster, H. Frischkorn, A. Serejo, J. F. Clark, P. Schlosser, W. S. Broecker & G. Bonani. 1995. Cooling of tropical Brazil (5°C) during the Last Glacial Maximum. *Science* 269: 379–383.
- Suárez, M., R. de la Cruz & C. M. Bell. 2000. Timing and origin of deformation along the Patagonian fold and thrust belt. *Geol. Mag.* 137: 345–353.
- Tapia, P. M., S. C. Fritz, P. A. Baker, G. O. Seltzer & R. B. Dunbar. 2003. A late Quaternary diatom record of tropical climatic history from Lake Titicaca (Peru and Bolivia). *Palaeogeogr. Palaeoclimatol. Palaeoecol.* 194: 139–164.
- Thouret, J.-C., T. van der Hammen, B. Salomons & E. Juvigné. 1996. Paleoenvironmental changes and glacial stades of the last 50,000 years in the Cordillera Central, Colombia. *Quatern. Res.* 46: 1–18.
- U.S. Geological Survey & Servicio Geológico de Bolivia. 1992. *Geology and mineral resources of the Altiplano and Cordillera Occidental, Bolivia*. *Bull. U.S. Geol. Surv.* 1975: 1–365.
- van der Hammen, T. 1952. *Geología del Río Apaporis entre Soratama y Cachivera La Playa*. Informe Servicio Geológica Nacional, Bogotá.

-
- & H. Hooghiemstra. 1995. The El Abra stadial, a Younger Dryas equivalent in Colombia. *Quatern. Sci. Rev.* 14: 841–851.
- & ———. 2000. Neogene and Quaternary history of vegetation, climate, and plant diversity in Amazonia. *Quatern. Sci. Rev.* 19: 725–742.
- , J. H. Werner & H. van Dommelen. 1973. Palynological record of the upheaval of the Northern Andes: A study of the Pliocene and Lower Quaternary of the Colombian Eastern Cordillera and the early evolution of its High-Andean biota. *Rev. Palaeobot. Palynol.* 16: 1–122.
- Veblen, T. T., K. R. Young & A. R. Orme (editors). 2007. *The Physical Geography of South America*. Oxford University Press, Oxford.
- Vuilleumier, B. S. 1971. Pleistocene changes in the fauna and flora of South America. *Science* 173: 771–780.
- Wallace, A. R. 1849. On the monkeys of the Amazon. *Proc. Zool. Soc. London* 20: 107–110.
- . 1876. *The Geographical Distribution of Animals*. Hafner, New York.
- Watts, W. A. & B. C. S. Hansen. 1994. Pre-Holocene and Holocene pollen of vegetation history from the Florida peninsula and their climatic implications. *Palaeogeogr. Palaeoclimatol. Palaeoecol.* 109: 163–176.
- Webb, R. S., D. H. Rind, S. J. Lehman, R. J. Healy & D. Sigman. 1997. Influence of ocean heat transport on the climate of the Last Glacial Maximum. *Nature* 385: 695–699.
- Winsemann, J. 1994. Origin and tectonic history of the western Caribbean. Pp. 1–15 *in* H. Seyfried & W. Hellmann (editors). *Geology of an Evolving Island Arc: The Isthmus of Southern Nicaragua, Costa Rica, and Western Panama*. Profil, Vol. 7. Institut für Geologie und Paläontologie, Universität Stuttgart, Stuttgart.
- Zeil, W. 1979. *The Andes, A Geological Review*. Gebrüder Borntraeger, Berlin.

CLIMATE IN THE DRY CENTRAL ANDES OVER GEOLOGIC, MILLENNIAL, AND INTERANNUAL TIMESCALES¹

Christa Placzek,² Jay Quade,³
Julio L. Betancourt,⁴ P. Jonathan Patchett,³
Jason A. Rech,⁵ Claudio Latorre,⁶ Ari Matmon,⁷
Camille Holmgren,⁸ and Nathan B. English³

ABSTRACT

Over the last eight years, we have developed several paleoenvironmental records from a broad geographic region spanning the Altiplano in Bolivia (18°S–22°S) and continuing south along the western Andean flank to ca. 26°S. These records include: cosmogenic nuclide concentrations in surface deposits, dated nitrate paleosoils, lake levels, groundwater levels from wetland deposits, and plant macrofossils from urine-encrusted rodent middens. Arid environments are often uniquely sensitive to climate perturbations, and there is evidence of significant changes in precipitation on the western flank of the central Andes and the adjacent Altiplano. In contrast, the Atacama Desert of northern Chile is hyperarid over many millions of years. This uniquely prolonged arid climate requires the isolation of the Atacama from the Amazon Basin, a situation that has existed for more than 10 million years and that resulted from the uplift of the Andes and/or formation of the Altiplano plateau. New evidence from multiple terrestrial cosmogenic nuclides, however, suggests that overall aridity is occasionally punctuated by rare rainfall events that likely originate from the Pacific. East of the hyperarid zone, climate history from multiple proxies reveals alternating wet and dry intervals where changes in precipitation originating from the Atlantic may exceed 50%. An analysis of Pleistocene climate records across the region allows reconstruction of the spatial and temporal components of climate change. These Pleistocene wet events span the modern transition between two modes of interannual precipitation variability, and regional climate history for the Central Andean Pluvial Event (CAPE; ca. 18–8 ka) points toward similar drivers of modern interannual and past millennial-scale climate variability. The north-northeast mode of climate variability is linked to El Niño–Southern Oscillation (ENSO) variability, and the southeast mode is linked to aridity in the Chaco region of Argentina.

Key words: Altiplano, Amazon Basin, Andes, CAPE, ENSO, middens.

The dry central Andes is the tripartite region encompassing the Altiplano, the Atacama, and the western Andean flank between ca. 18°S and 27°S (Fig. 1) and is a critical region for understanding the drivers of tropical climate change at multiple timescales. Arid environments are often uniquely sensitive to climate change, and today modern interannual climate variability in the region is pronounced and influenced by both tropical climate phenomena, such as El Niño–Southern Oscillation (ENSO), and moisture levels in the extratropical lowlands east of the Andes (Fig. 2) (Vuille & Keimig, 2004). Here, we compare the

timing and likely drivers of precipitation changes across the dry central Andes over geologic, millennial, and interannual timescales. Understanding how regional climate is sensitive to processes like mountain building, the reorganization of global atmospheric circulation that occurs over glacial-interglacial and millennial timescales, and decadal to interannual changes due to processes such as the ENSO phenomenon is a step toward assessing where and how this region is sensitive to global climate change.

The Atacama Desert, located along the western Andean slope between ca. 18°S and 26°S (Fig. 1), is

¹ We thank Sohrab Tawakholi and Servicio Nacional de Geología y Minería (SERGEOMIN) for field logistical support in Bolivia. This work was supported by the National Science Foundation (grant EAR-0207850 to J.Q. and J.P., and grant 02-13657 to J.Q. and J.B.) and by grants from the Geological Society of America, the Arizona Geological Survey, Chevron, and University of Arizona Accelerator Facility. C.P. is currently funded by National Science Foundation grant 01-01249. C.L. has received grants Proyecto Fondo Basal-23 and the Iniciativa Científica Milenio P05-002 (to the Institute of Ecology and Biodiversity), as well as the Fondo de Desarrollo de Áreas Prioritarias grant 1501 (to the Center for Advanced Studies in Ecology and Biodiversity) and the Fondo Nacional de Desarrollo Científico y Tecnológico grant 1060496.

² Purdue Rare Isotope Measurement Laboratory and Department of Earth and Atmospheric Sciences, Purdue University, West Lafayette, Indiana 47907, U.S.A. cplaczek@purdue.edu.

³ Department of Geosciences, University of Arizona, Tucson, Arizona 85721, U.S.A.

⁴ U.S. Geological Survey, Desert Laboratory, 1675 Anklam Rd., Tucson, Arizona 85745, U.S.A.

⁵ Department of Geology, 123 Shideler Hall, Miami University, Oxford, Ohio 45056, U.S.A.

⁶ CASEB/Departamento de Ecología, Pontificia Universidad Católica de Chile and Institute of Ecology and Biodiversity, Casilla 653, Santiago, 6513677, Chile.

⁷ Institute of Earth Sciences, The Hebrew University of Jerusalem, Givat Ram, Jerusalem, Israel.

⁸ Geography and Planning Department, Buffalo State College, 1300 Elmwood Ave., Buffalo, New York 14222, U.S.A.

doi: 10.3417/2008019

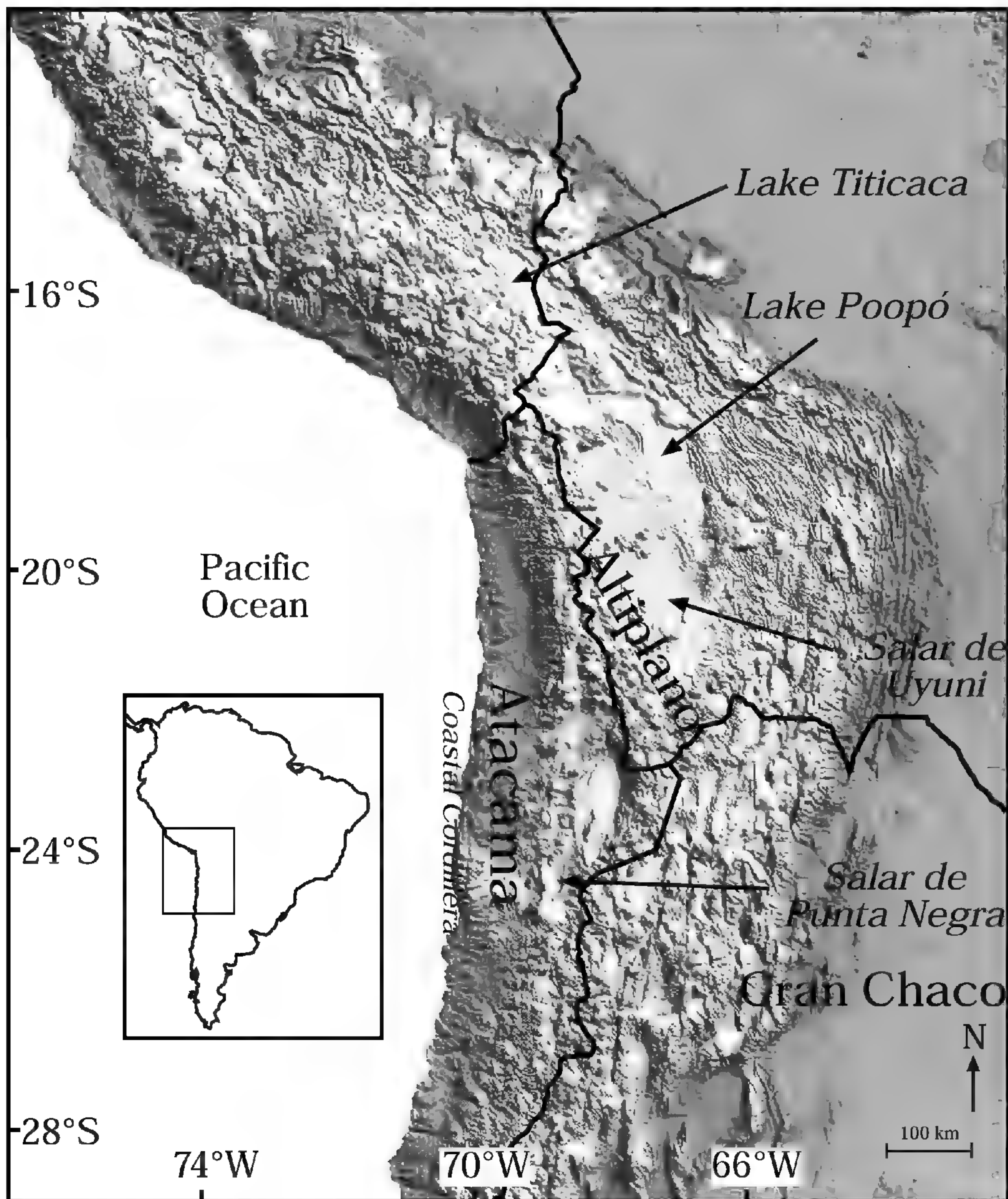

Figure 1. Location of relevant sites and geographic features in the dry central Andes.

the driest and perhaps oldest desert on earth (Hartley et al., 2005). Hyperaridity requires orographic exclusion of Atlantic moisture by the Andes and exclusion of Pacific moisture by the Coastal Cordillera and subsiding air resulting from the cold, northward-flowing Humboldt Current. The stability and timing of moisture exclusion from these two sources are critical to determining if the Andean uplift created the Atacama or if this aridity results from changes along

the Pacific coast (Lamb & Davis, 2003). Despite this prolonged aridity, major changes have occurred in the boundary conditions that contribute to hyperaridity since the Andes acquired enough elevation to constitute a significant orographic barrier. These changes include uplift of the Coastal Cordillera (e.g., Clift & Hartley, 2007) and changes in the intensity of the Humboldt Current (e.g., Molnar & Cane, 2007) related to expansion of Antarctic ice

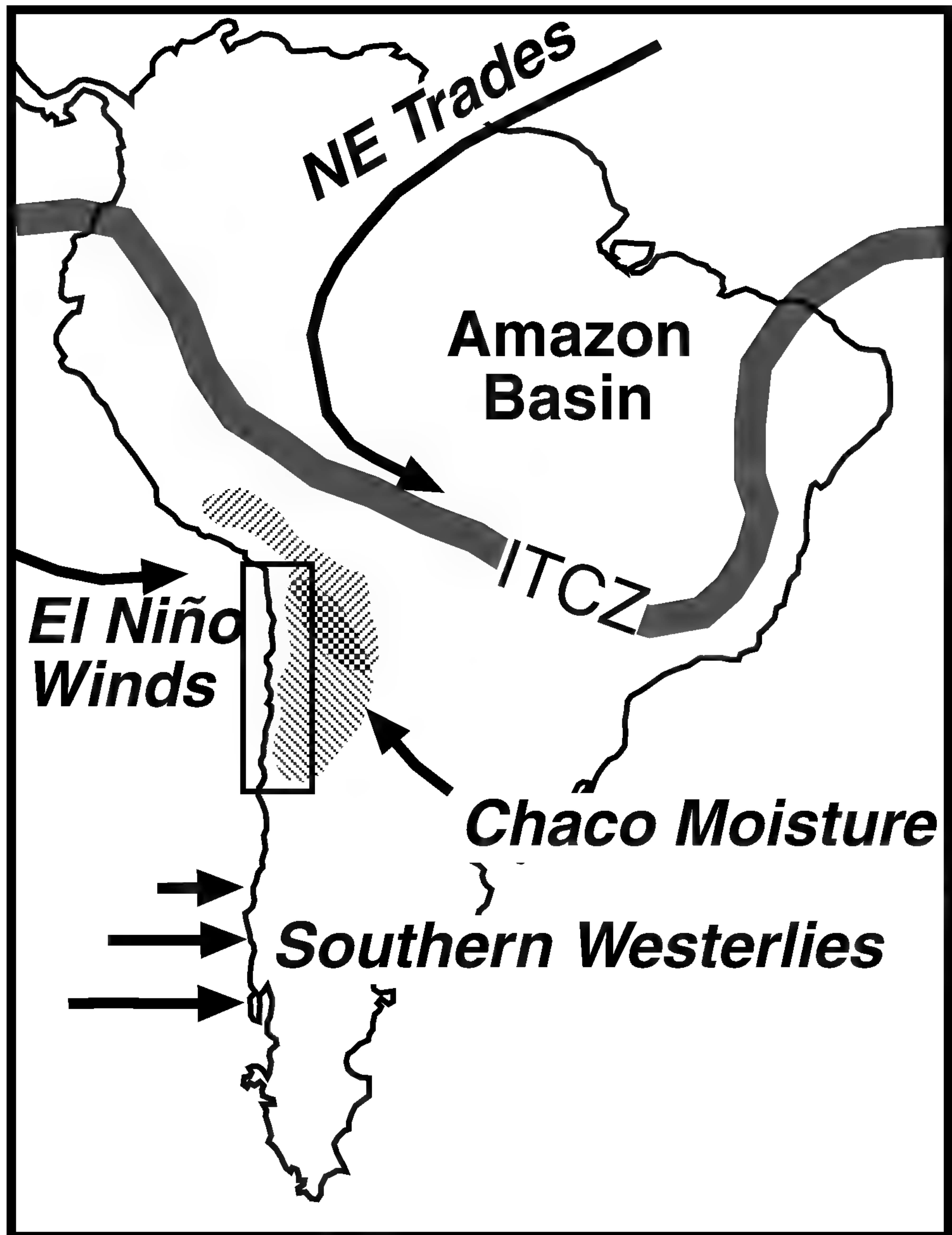

Figure 2. Modern climate systems controlling central Andean rainfall. Overlapping shaded zones show the two modes of modern precipitation, as major rotated empirical orthogonal functions, identified by Vuille and Keimig (2004). The north-northwest mode is modulated by El Niño–Southern Oscillation (ENSO), with strong westerly winds producing drought on the Altiplano during El Niño years. The southeast mode is correlated with lowland humidity in the Chaco region of Argentina. The Intertropical Convergence Zone (ITCZ) is shown in its southernmost (summer) position.

sheets (e.g., Hartley & Chong, 2002) and/or closing of the Isthmus of Panama (Ibaraki, 1997).

The evidence for prolonged hyperaridity in the core of the Atacama Desert is matched by paleoecological (e.g., Grosjean et al., 1997; Betancourt et al., 2000; Latorre et al., 2002, 2006) and paleohydrological (e.g.,

Betancourt et al., 2000; Bobst et al., 2001; Rech et al., 2002; Quade et al., 2008) evidence for dramatic millennial scale changes in climate along the fringes of the Atacama Desert. Thus, the boundaries of the Atacama Desert fluctuate in response to these climatic events, and the distribution and stability of these

boundaries through time can give insights into the causes of these shifts. Recent evidence (e.g., Quade et al., 2008) suggests that ancient millennial scale variability had two geographically distinct modes, similar in distribution to two distinct modes of modern interannual rainfall variability.

ATACAMA HYPERARIDITY

The hyperaridity of the Atacama Desert is due to a combination of: (1) the extreme rain shadow created by the high Andes and Altiplano, which excludes moisture from the Amazon Basin; (2) a strong temperature inversion along the Pacific coast, which effectively blocks Pacific moisture at ca. 1000 m elevation along the western flank of the Coastal Cordillera; and (3) the northern limit of the southern Westerlies (Houston & Hartley, 2003). Over millions of years, the rain shadow created by the high Andes and/or Altiplano plateau was primarily responsible for the prolonged aridity of the Atacama Desert. An Andean elevation of at least 2000 m is considered high enough to exclude much of the moisture originating in the Amazon Basin from the Atacama (e.g., Masek et al., 1994; Rech et al., 2006). The details and timing of central Andean uplift and formation of the Altiplano plateau and the interaction between climate and tectonics in the central Andes remain unresolved (e.g., Barnes et al., 2006; Garzione et al., 2006; Ghosh et al., 2006).

One of the primary lines of evidence for both a landscape and climate that has remained stable and hyperarid over the entire Pliocene and Pleistocene is extremely high cosmogenic nuclide concentrations from ancient geomorphic surfaces. Cosmogenic nuclides are produced by secondary cosmic rays in the uppermost few meters of the earth's surface and can record the age of material suddenly exposed or constrain erosion rates (Lal, 1991). Cosmogenic nuclide concentrations from stable geomorphic surfaces in the Atacama result in some of the oldest exposure ages found anywhere on earth, ranging between 9 and 37 million years ago (Ma) (Dunai et al., 2005; Nishiizumi et al., 2005; Kober et al., 2007). Indeed, the Atacama is one of the few locations where exposure ages must be verified by stable ^{21}Ne measurements, as long exposure times mean that significant quantities of the radionuclides ^{10}Be and ^{26}Al produced during early exposure have decayed. Constraints on the rates of sediment production and transport in the Atacama also come from cosmogenic nuclide concentrations in multiple components of the landscape (Placzek et al., 2007) and deposition rates inferred from dated ash-fall tuffs (Placzek et al., 2009). Together, these indicate that overall erosion

rates are some of the slowest in the world—a direct result of a prolonged arid climate.

Additional evidence for the onset of aridity prior to 10 Ma includes: accumulation of nitrate soils in ancient deposits (Rech et al., 2006), an end of supergene mineralization (e.g., Alpers & Brimhall, 1988; Sillitoe & McKee, 1996; Arancibia et al., 2006), and changes in stream morphology on the Andean flank (Hoke et al., 2006). Ancient nitrate soils, with a firm minimum age of 9.4 Ma from an overlying volcanic ignimbrite, attest to this ancient aridity as nitrates require hyperarid conditions and today only accumulate in the driest portions of the Atacama Desert. These nitrate soils, however, probably represent several million years of accumulation, and Rech et al. (2006) place the minimum age for the onset of hyperaridity at ca. 13 Ma.

At odds with all this evidence for prolonged hyperaridity is an inferred association between the degree of aridity and the deposition of fluviolacustrine, alluvial fan or evaporite deposits, which leads to the conclusion that Pliocene sediments suggest a transition from arid to hyperarid conditions as recently as 3 Ma (Hartley & Chong, 2002; Allmendinger et al., 2005). Today, all of these depositional environments occur both in the wetter Andean highlands and across the “absolute desert,” a broad expanse of the Atacama Desert completely devoid of precipitation and vascular plants, thus confounding interpretation of modern or ancient aridity from such sediments. Cosmogenic nuclide concentration from the active components of the landscape (surface gravel, active alluvial fan deposits, and active channels) appears to be eroding at a rate that is at least an order of magnitude faster than relict geomorphic surfaces (Placzek et al., 2007). Furthermore, new ^{21}Ne , ^{10}Be , and ^{26}Al measurements from relict boulders indicate that many of these boulders have ages less than 3 Ma (Placzek et al., 2008), long after the onset of aridity. This movement and erosion of all size classes of sediment after 3 Ma suggest that periodic rainfall and flood events continue to impact the Atacama. Furthermore, it suggests that the Atacama Desert, traditionally viewed as isolated from rainfall over geologic intervals, has a modern landscape that is shaped by rare, but recent, rain events and is therefore not fully isolated from future global climate change.

MILLENNIAL-SCALE CLIMATE CHANGE

Climate proxies from lakes, wetland deposits, and urine-encrusted rodent middens reveal dramatic precipitation changes throughout the Pleistocene over a broad geographic region. Here, we focus on the paleolake record from the Altiplano and what it

reveals about climate variability over the Pleistocene. We also compare this lake record to other types of climate proxies across this region during the post late glacial-age Central Andean Pluvial Event (CAPE), concluding with an example of how a multiproxy approach allows tracking of the source of moisture during wet intervals.

LAKE RECORDS

Four large lake basins (Fig. 1: Titicaca, Poopó, Coipasa, and Uyuni) dominate the Altiplano, and the size of the lakes has undergone periodic changes as a result of changes in precipitation. In the north, Lake Titicaca (3806 m elevation, 8560 km²) is a freshwater lake that is more than 284 m deep (Argollo & Mourguiart, 2000) and loses less than 10% of its annual water budget to overflow into the Río Desaguadero (Roche et al., 1992). The Río Desaguadero empties into the oligosaline Lake Poopó (3685 m, 2500 km²), which is separated by a topographic divide, the Laka sill (3700 m), from the Salar de Coipasa (3656 m, 2530 km²) and Salar de Uyuni (3653 m, 12,100 km²). In wet years these salt flats are connected and filled with shallow water (< 4 m) (Argollo & Mourguiart, 2000).

Within these basins, multiple sites were studied and sampled as part of a comprehensive effort to obtain and replicate records of lake-level change from multiple localities in all three major basins. Particular effort was directed toward sedimentary deposits associated with various visible paleoshorelines. This approach to reconstructing lake-level history allows for direct determination of lake level, replication of stratigraphy, and dating by two geochronologic methods (¹⁴C and U-Th, Placzek et al., 2006b). More than 170 dates are available from paleolake deposits within the basins, and the use of both the U-Th and radiocarbon methods allowed us to extend our record beyond the limit of radiocarbon dating (ca. 45 ka). The focus of this dating effort is sedimentary deposits indicative of a near-shore environment and the massive encrustations of calcium carbonate (tufas) found in the paleolake basins. Tufas and aquatic gastropod shells generally form in nearshore environments and incorporate ¹⁴C and uranium from water in which they precipitate. For samples younger than 45 ka, the quantity of remaining radioactive ¹⁴C can be used to calculate a sample's age. For older samples (greater than 25 ka), however, the very small quantity of remaining ¹⁴C renders samples susceptible to errors introduced by contamination with very small amounts of modern carbon. Thus, reliable ages greater than 25 ka come from the U-Th dating method, which is based on the premise that uranium is incorporated

into carbonates precipitated from water, but thorium, a daughter of uranium decay, is largely not incorporated into tufas. Sediments that are clearly associated with lake shorelines or sedimentary units showing both deep and shallow lake events place constraints on absolute paleolake elevation. The potential incompleteness of any single exposure is redressed by replication of stratigraphy at multiple locations (Placzek et al., 2006a).

On the Altiplano, extensive natural exposures reveal evidence of two deep-lake and several minor-lake cycles over the past 120 ka (Fig. 3) in an area where today there are mostly barren salt flats or shallow saline lakes. The Ouki lake cycle was ca. 80 m deep, and 19 U-Th dates place this deep-lake cycle between 120 and 98 ka (Placzek et al., 2006a). Old shoreline and sedimentary deposits from the Ouki lake cycle are extensively exposed in the Poopó Basin, but no deep lakes are apparent in the subsequent record between 98 and 18.1 ka. Evidence of shallow lakes is present in the Uyuni Basin between 95 and 80 ka (Salinas lake cycle), at ca. 46 ka (Inca Huasi lake cycle), and between 24 and 20.5 ka (Sajsi lake cycle) (Fig. 3). The Tauca lake cycle occurred between 18.1 and 14.1 ka, resulting in the deepest (ca. 140 m) and largest lake in the basin over the past 120 ka. Multiple ¹⁴C and U-Th dates constrain the highest elevation of the Tauca lake cycle along a topographically conspicuous shoreline between 16.4 and 14.1 ka. The Coipasa lake cycle produced a ≤ 55 m deep lake with ages between ca. 13 and 11 ka (Placzek et al., 2006a). Together, the Tauca and Coipasa lake cycles evidence the occurrence of CAPE on the Bolivian Altiplano (Fig. 4).

RODENT MIDDENS

Urine-encrusted rodent middens (henceforth, rodent middens) are complex nests of local vegetation and feces encased in crystallized rodent urine. In arid climates, rodent middens are preserved underneath rock slabs and within caves. Plant remains encased in middens reflect former vegetation cover within the rodent's foraging range, which is usually less than 200 m (cf. Salinas & Latorre, 2007). In the dry central Andes, middens are produced by at least four different rodent families: Abrocomidae (*Abrocoma cinerea* Thomas, chinchilla rats), Chinchillidae (*Lagidium viscacia* Molina and *Lagidium peruanum* Meyen, southern mountain viscacha), Muridae (*Phyllotis* spp., leaf-eared mice), and Octodontidae (*Octodontomys gliroides* Gervais & d'Orbigny [1884], mountain degu [Latorre et al., 2005]). These rodents collect plants for consumption and nest building, and studies of modern *Phyllotis*, *Lagidium*, and *Abrocoma*

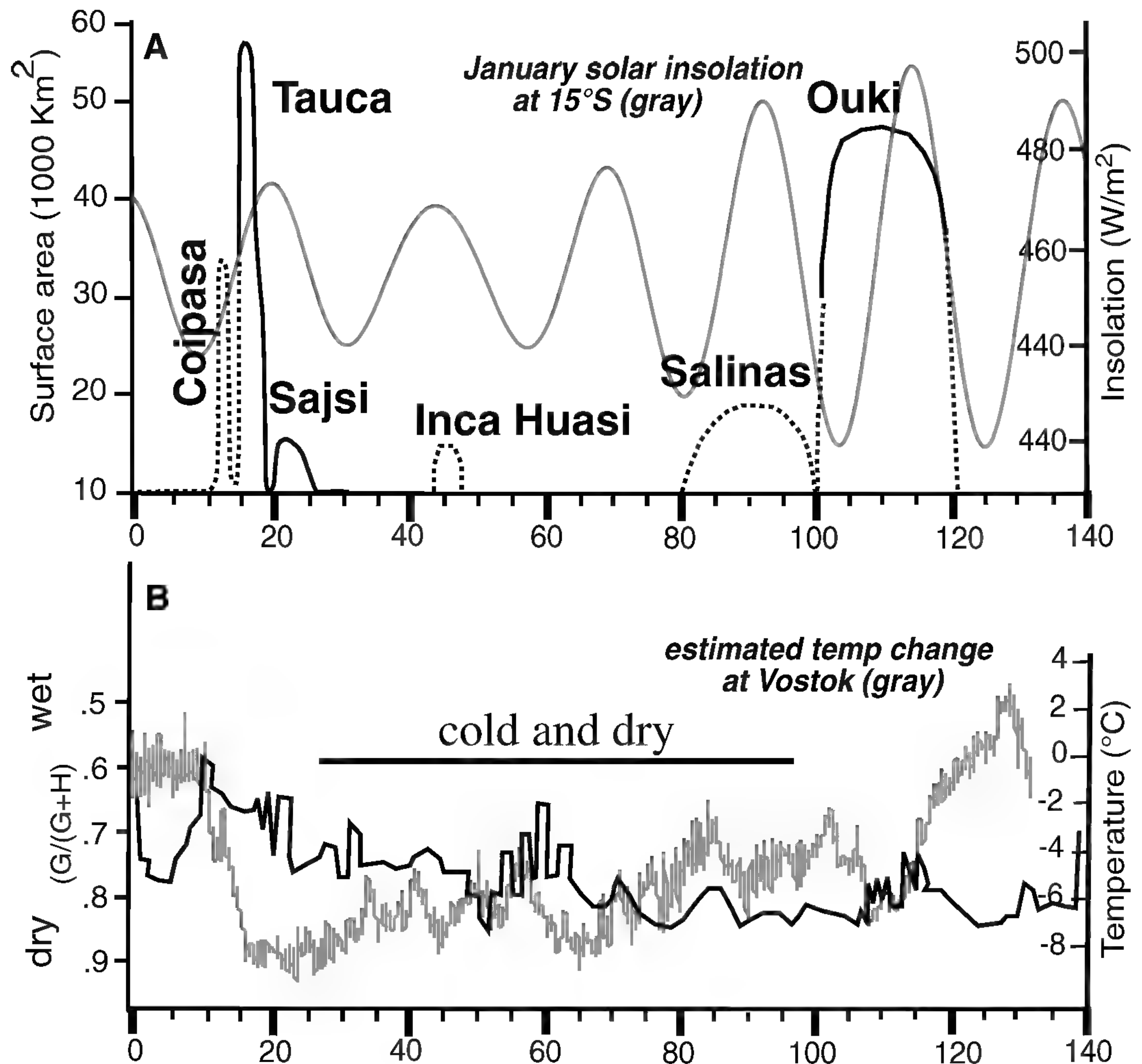

Figure 3. —A. Reconstructed lake history from shoreline deposits. January insolation (in watts/m²) at 15°S (Laskar, 1990) is given in gray. —B. Iron oxide composition (goethite/[goethite + hematite]) of sediments derived from the Amazon (Harris & Mix, 1999) and estimated temperature change at Vostok (gray) (Petit et al., 1999). X axis values denote time in ka.

indicate that they are dietary generalists (cf. Cortés et al., 2002), and as such they are not likely to introduce large selective biases into the midden record.

Due to the abundance of plant macrofossils, rodent middens are rich snapshots of local paleoecology at the finite (and datable) time they were deposited. Rodent middens deposited within the last 45 ka are dated using standard ¹⁴C techniques. Analysis of ancient vegetation assemblages is most effective when coupled with surveys of modern vegetation in and around a collection site. The most basic analysis of rodent middens typically involves assessment of the percent of extra-local plant species contained in a midden and some interpretation of the relative climate (wetter, dryer, warmer, colder) represented by that

assemblage. At the outer edges of the Atacama Desert, middens containing abundant vegetation are found on landscapes that are currently too dry to support plants (Betancourt et al., 2000; Latorre et al., 2002). A simple proxy for precipitation amount from the central Andean midden record is the relative abundance of grass, as modern grasslands are currently found where there is higher precipitation present in fossil middens near the boundary of the Atacama Desert (Latorre et al., 2003, 2005, 2006). The percentage of grass abundance from rodent middens on the fringes of the absolute desert in the Salar de Punta Negra region is generally high during the CAPE (Latorre et al., 2002). Here, rodent middens from the second phase of CAPE have a higher percentage of grass abundance than the first phase of CAPE (Fig. 4).

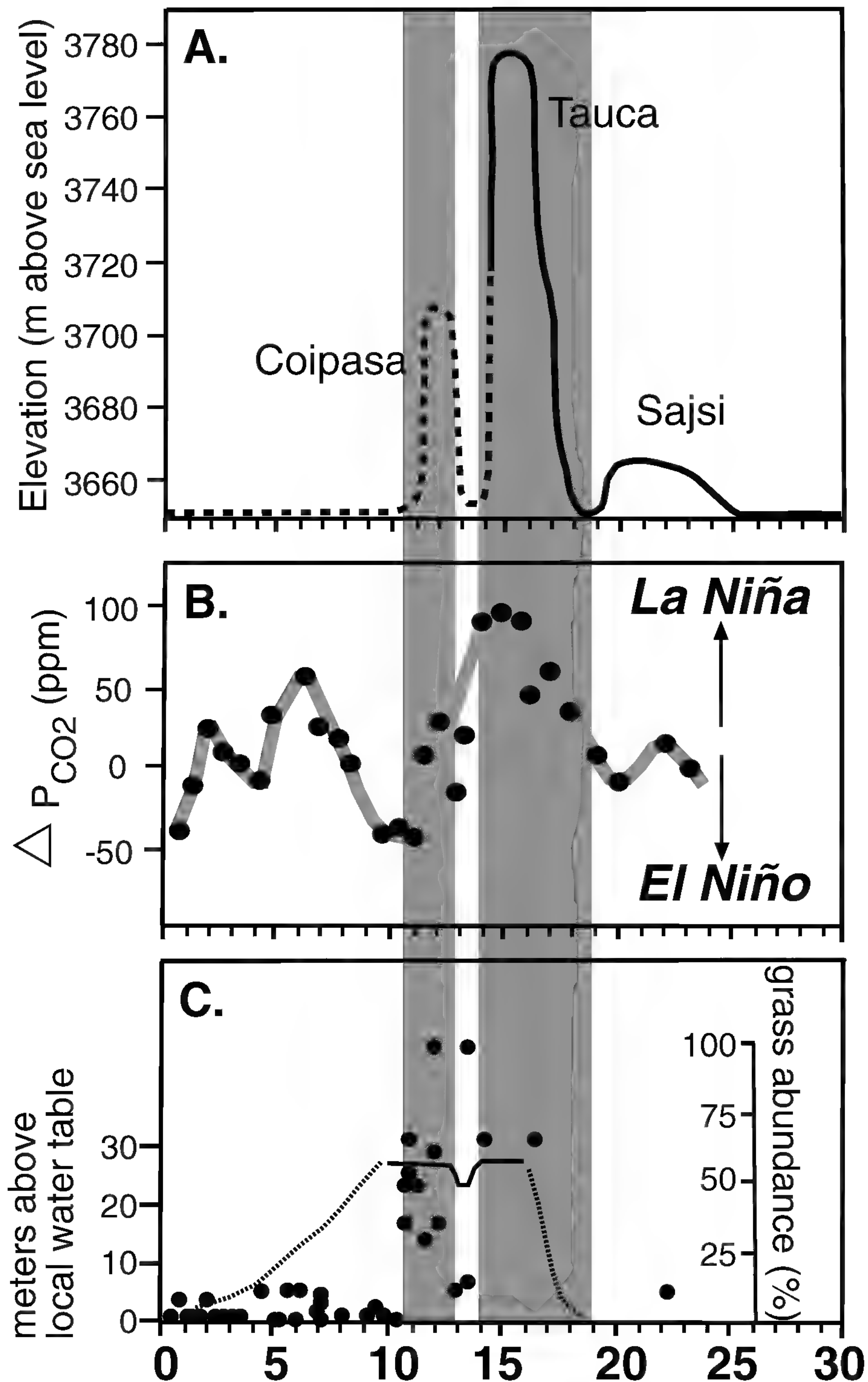

Figure 4. Comparison of paleohydrologic and climate proxies during the Central Andean Pluvial Event (CAPE). —A. Reconstructed lake-level curve. —B. Change in pCO₂ in the Western Equatorial Pacific inferred from boron isotope analyses of planktonic foraminifera, in which increased pCO₂ is associated with stronger upwelling and La Niña-like conditions (Palmer & Pearson, 2003). —C. Reconstructed water table height (Quade et al., 2008) and percentage of grass abundance from rodent middens in the Salar de Punta Negra area (Latorre et al., 2002). X axis values denote time in ka.

PALEOWETLANDS

Wetlands form where the water table intersects the land surface and can be found either within steep-walled washes or in less confined settings where small local closures allow pooling of shallow freshwater and the formation of wetland deposits (Rech et al., 2002, 2003; Grosjean et al., 2005; Quade et al., 2008). Paleowetland deposits generally consist of fine sand, silt, and biogenic deposits such as organic-rich mats, diatomites, and tufa. The abundance of organic material in these deposits makes them relatively easy to date using radiocarbon, and multiple stratigraphic levels within a deposit can often be dated. Furthermore, the abundance of these deposits in the Atacama allows replication of results both within and between sites. Questions regarding hydrologic response time can be resolved by comparison of wetlands from several different settings; in the Atacama we find that increased precipitation in the high Andes is very rapidly translated into water table rise at multiple locations across the Atacama (Rech et al., 2002, 2003; Quade et al., 2008). High water tables in the Salar de Punta Negra region indicate that CAPE began in this region at ca. 17 ka, but may have terminated as late as 8 ka (Fig. 4).

SPATIAL AND TEMPORAL EXTENT OF THE CAPE

Evidence from the CAPE is relatively recent and well preserved, allowing evaluation of the spatial and temporal distribution of climate change over the entire dry central Andes. The CAPE is divided into two phases, and the depths of the Tauca and Coipasa lake cycles suggest that the first phase of CAPE on the Altiplano was the wettest and began at ca. 18 ka. This contrasts with climate records from wetlands in the Punta Negra region (ca. 4°S of the Uyuni Basin), where high water tables indicate that the second phase of CAPE began ca. 1000 years after the transgression of Lake Tauca. In both areas, the first phase of CAPE terminates abruptly at ca. 14.1 ka and is soon followed by a second wet interval (Fig. 4). The second phase of CAPE created the shallower Lake Coipasa on the Altiplano, but the midden record from the Salar de Punta Negra region has a higher percentage of grass abundance during the second phase of CAPE, an indication that this second phase was wetter toward the south (Latorre et al., 2002). While the termination of both the Coipasa lake cycle and CAPE in the Punta Negra region is poorly constrained in time, the second phase also seems to be longer lived to the south (Quade et al., 2008).

Paleolake shoreline evidence from the Altiplano also supports the assertion that the Coipasa lake cycle

was sustained mainly from precipitation in the southern Coipasa and Uyuni basins. Climate affects lake levels in closed basins by altering the hydrologic balance between runoff, precipitation, and evaporation while basin topography influences lake levels by altering the surface area:volume ratio. In large lake systems elsewhere (e.g., Bonneville, Lahontan, Lisan), well-developed shorelines correspond to periods when a lake level was stabilized as a result of spilling over into an arid receiving basin at a lower level (Curry & Oviatt, 1985; Benson & Paillet, 1989; Benson et al., 1990; Bartov et al., 2002). Thus, a lake system is buffered to climate fluctuations at the level of a spillway because the receiving basin must fill before the lake in the spillover basin can again rise. The degree of buffering depends on the relative size of the two basins. In the case of the Poopó-Coipasa-Uyuni system, the Poopó Basin is considerably smaller (< 1/3 the size) than the combined Coipasa-Uyuni basins (Fig. 5). Thus, if a lake filled these basins with water from the north (the Titicaca and Poopó basins), then such a lake would have a relatively long period of stability at the level of the Laka sill (the spillway between Poopó and Coipasa). This should result in a prominent shoreline in the Poopó Basin at ca. 3700 m, the elevation of the Laka sill. In contrast, if a lake filled the larger and more southern Coipasa and Uyuni basins first, then the percentage of change in surface area at the level of the Laka sill is much smaller, so pronounced shorelines would not develop (Fig. 5). The maximum elevation of the Coipasa lake cycle remains poorly constrained because a prominent shoreline is not visible. Chronological evidence, however, suggests that at its maximum extent the Coipasa lake cycle approximated the elevation of the Laka sill.

MODERN CLIMATE VARIABILITY

Today, the sources, timing, and variability of precipitation are different for the northern Altiplano, the southern Altiplano, western Andean flank, and the Atacama. On the northern Altiplano, more than 80% of total annual precipitation falls in the austral summer (December to March) (Vuille, 1999), and this moisture traverses the Amazon Basin in the summer months when the Intertropical Convergence Zone (ITCZ) is displaced southward and convection is most intense in the Amazon Basin (Lenters & Cook, 1997) (Fig. 2). This moisture source to the north and east of the Altiplano produces a pronounced north-south gradient and is referred to as the South American Summer Monsoon (SASM) (e.g., Zhou & Lau, 1998). The SASM on the northern Altiplano is modulated by ENSO variability, and the strength of the trade winds

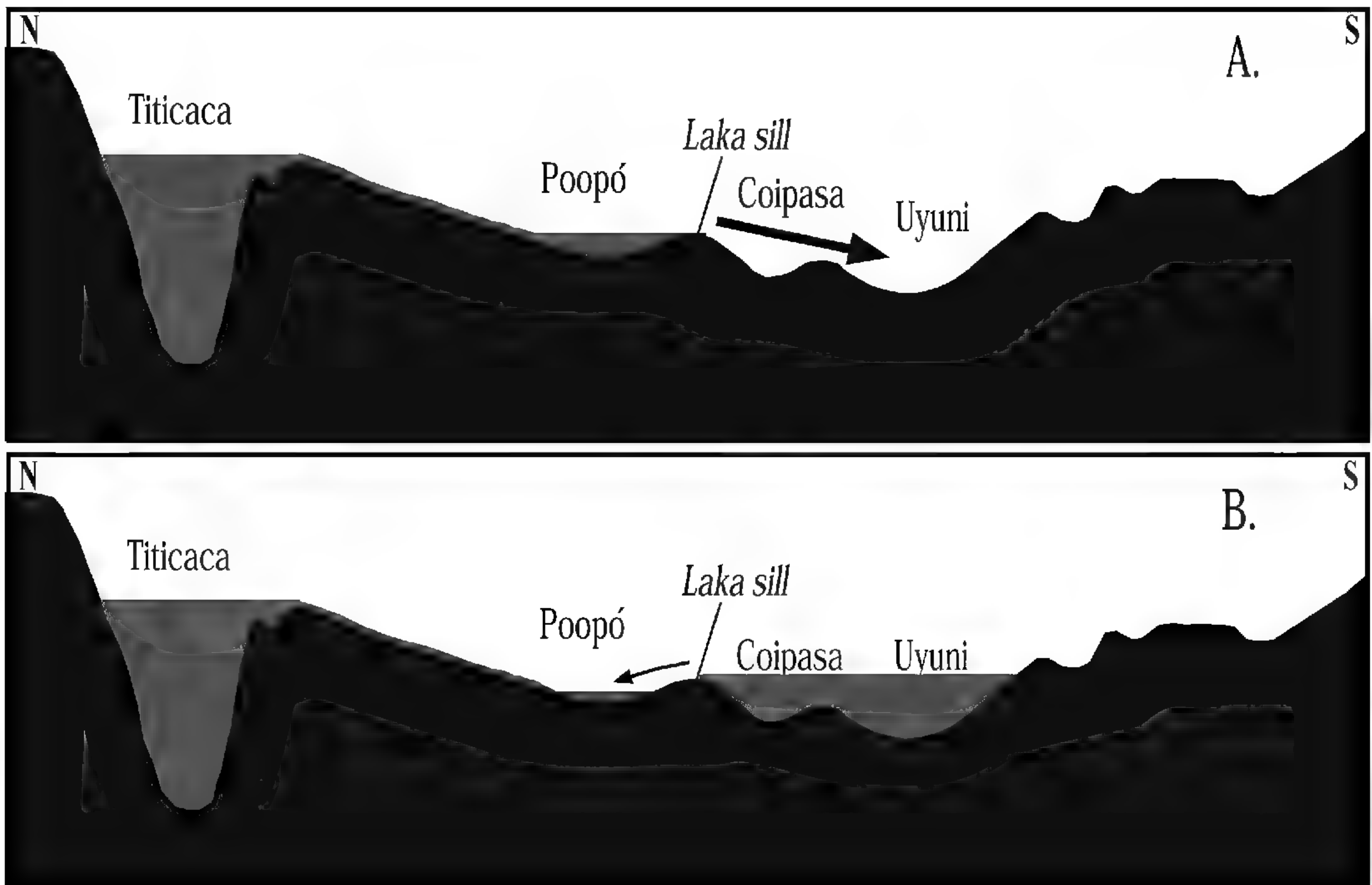

Figure 5. Schematic cross section of the Titicaca-Poopó-Coipasa-Uyuni hydrographic basin. Vertical exaggeration is ca. 830 \times . —A. Filling of the basins from the north. —B. Filling of the basins largely from the south.

is strong in La Niña years, resulting in increased precipitation. Conversely, during El Niño years, aridity dominates in upland Peru and Bolivia, but torrential rains occur along the Pacific coast (Aceituno, 1988; Vuille et al., 1998, 1999; Garreaud & Aceituno, 2001; Vuille & Keimig, 2004).

In contrast, summer rainfall on the southern Altiplano and western Andean flank has a mode of variability that is closely tied to precipitation anomalies and humidity levels over the Chaco region of Argentina (Vuille & Keimig, 2004). Thus, today there are two distinct modes of variability in summer rainfall (Vuille & Keimig, 2004) (Fig. 2). The north-northeast mode is tied to ENSO variability, and the southeast mode is tied to extratropical precipitation anomalies in the lowlands east of the Andes. Unfortunately, a more complete understanding of this southern mode of modern climate in the dry central Andes is hampered by a lack of reliable and continuous precipitation data. Recent advances in the isotope hydroecology of columnar cacti and their spines (English et al., 2007) and tropical dendrochronology (e.g., Evans & Schrag, 2004; Anchukaitis et al., 2008) should produce more detailed records of recent climate throughout South America.

In contrast to the Atlantic moisture falling on the Altiplano and Andes, the Pacific is likely the source of the scant precipitation that falls today in the

Atacama. Pacific moisture is effectively excluded from the dry central Andes by the descending limb of the southeast Pacific anticyclone under the influence of the cold Humboldt Current (Vuille, 1999), which has likely been active since the early Tertiary (ca. 65 Ma) (Keller et al., 1997). The steep Coastal Cordillera also limits the inland penetration of Pacific fog to a narrow elevation band (500–1000 m). Although the Coastal Cordillera largely blocks Pacific storms, rare precipitation events may penetrate the Atacama Desert in the austral winter (May through July). These storm fronts typically migrate northward from the westerly precipitation belt that forms the southern boundary of the Atacama at ca. 26°S (Vuille & Ammann, 1997). Today, Pacific sea surface temperature gradients modulate penetration of these Pacific fronts into the Atacama and western Andean flank, and El Niño years are associated with increased precipitation and/or fog intensity in the Atacama (Dillon & Rundel, 1990).

CLIMATE CHANGE IN THE DRY CENTRAL ANDES: MECHANISMS AND IMPLICATIONS

Potential causes of climate change in the dry central Andes include: (1) changes in seasonality, especially local summer insolation (e.g., Baker et al., 2001a, b; Rowe et al., 2002; Fritz et al., 2004); (2)

changes in global temperature (e.g., Blodgett et al., 1997; Garreaud et al., 2003); (3) changes in aridity over the Amazon Basin (e.g., Mourguiart & Ledru, 2003); and (4) changes in sea surface temperature gradients (e.g., Betancourt et al., 2000; Garreaud et al., 2003; Placzek et al., 2006b; Quade et al., 2008). Our lake chronology strongly argues against simple forcing of summer precipitation by summer insolation, and we rule out local January insolation as the primary driver of lake cycles; both deep lakes occur during periods of low to moderate local summer insolation. The Tauca lake cycle reached a maximum between 16.4 and 14.1 ka, ca. 5 ka after the insolation peak at ca. 20 ka (Fig. 3), and the Ouki lake cycle spans the most profound minimum (105–100 ka) in January insolation in the past 200 ka. Similarly, the Ouki lake cycle and the CAPE occur during periods of moderate global temperature, indicating no direct link between precipitation changes and temperature. Past, present, and possibly future climate changes in aridity over the region are, however, likely linked to changes in ENSO variability and moisture level in the eastern lowlands.

CAPE allows examination of the interaction between ENSO and precipitation anomalies over the Gran Chaco lowlands during past wet events over the dry central Andes. Chronology and climate proxy data for CAPE suggest a temporal offset between the Altiplano lake record and the Salar de Punta Negra wetland and rodent midden record. We attribute this to the operation of two separate modes of rainfall over the northern and southern portions of the central Andes during CAPE. The timing of the first phase of CAPE coincides with evidence for intense upwelling (La Niña) in the central Pacific between 18 and 13 ka (Palmer & Pearson, 2003) (Fig. 4). La Niña-like conditions today result in wet years on the Altiplano, and important ancient links may exist between central Andean moisture and Pacific sea surface temperature gradients during the Pleistocene. The modern link between ENSO anomalies and precipitation variability is weaker farther south where CAPE starts ~1000 years later. The second phase of CAPE created the shallower Coipasa lake cycle, but was the more significant precipitation event farther south (Fig. 4). Similarly, modern precipitation anomalies on the western Andean flank to the south are tied more closely to circulation anomalies over the Gran Chaco.

CONCLUSIONS

Hyperaridity in the core of the Atacama Desert dominates over a period greater than 10 Ma, in contrast to the western Andean flank and the Altiplano, where evidence from a variety of climate

proxies points toward significant changes in paleoprecipitation during the Pleistocene. Over long periods of time (> 10 Ma), the uplift of the Andes and the formation of the Altiplano plateau are critical in the formation of the Andean rain shadow, making the Atacama Desert uniquely long-lived and arid. Conversely, summer insolation over the Altiplano plateau does not appear to drive changes in precipitation over the Altiplano or Amazonia over millennial and glacial-interglacial timescales. Instead, evidence, from both modern climate and paleorecords, increasingly points to ENSO-like variability and extratropical moisture over the Gran Chaco region of Argentina as causal mechanisms for climate variability on the Altiplano and western Andean flank. These two modes of modern central Andean climate variability appear to operate over different geographic regions and at different time intervals. ENSO variability is currently more significant on the Altiplano and, during the earliest phase of CAPE (18.1–14.1 ka), may be linked to intense and prolonged La Niña-like conditions. In contrast, extratropical moisture is today more significant on the western Andean flank and may play a greater role during the latter phase of CAPE (after 13 ka). Thus, modern climate variability and past millennial scale variability appear to be forced by the same mechanisms and suggest that future climate changes in the region will not come as a direct result of temperature shifts, but rather from teleconnections to global circulation patterns such as ENSO.

Literature Cited

- Aceituno, P. 1988. On the functioning of the Southern Oscillation in the South America sector. Part I: Surface climate. *Monthly Weath. Rev.* 116: 505–524.
- Allmendinger, R. W., G. González, J. Yu, G. Hoke & B. Isacks. 2005. Trench-parallel shortening in the Northern Chilean Forearc: Tectonic and climatic implications. *Bull. Geol. Soc. Amer.* 117: 89–104.
- Alpers, C. N. & G. H. Brimhall. 1988. Middle Miocene climatic change in the Atacama Desert, northern Chile: Evidence from supergene mineralization at La Escondita. *Bull. Geol. Soc. Amer.* 100: 1640–1656.
- Anchukaitis, K. J., M. N. Evans, N. T. Wheelwright & D. P. Schrag. 2008. Stable isotope chronology and climate signal calibration in neotropical montane cloud forest trees. *J. Geophys. Res.* 113: G03030.
- Arancibia, G., S. J. Matthews & C. Perez de Arce. 2006. K–Ar and $^{40}\text{Ar}/^{39}\text{Ar}$ Geochronology of supergene processes in the Atacama Desert, northern Chile: Tectonic and climatic relations. *J. Geol. Soc. London* 163: 107–118.
- Argollo, J. & P. Mourguiart. 2000. Late Quaternary climate history of the Bolivian Altiplano. *Quatern. Int.* 72: 36–51.
- Baker, P. A., C. A. Rigsby, G. O. Seltzer, S. C. Fritz, T. K. Lowenstein, N. P. Bacher & C. Veliz. 2001a. Tropical climate change at millennial and orbital timescales on the Bolivian Altiplano. *Nature* 409: 698–701.

- , G. O. Seltzer, S. C. Fritz, R. B. Dunbar, M. J. Grove, P. M. Tapia, S. L. Cross, H. D. Rowe & J. P. Broda. 2001b. The history of South American tropical precipitation for the past 25,000 years. *Science* 291: 640–643.
- Barnes, J. B., T. A. Ehlers, N. McQuarrie, P. B. O'Sullivan & J. D. Pelletier. 2006. Eocene to recent variations in erosion across the central Andean fold-thrust belt, northern Bolivia: Implications for plateau evolution. *Earth Planet. Sci. Lett.* 248: 118–133.
- Bartov, Y., M. Stein, Y. Enzel, A. Agnon & Z. Reches. 2002. Lake levels and sequence stratigraphy of Lake Lisan, the Pleistocene precursor of the Dead Sea. *Quatern. Res.* 57: 9–21.
- Benson, L. V. & F. L. Paillet. 1989. The use of total lake-surface area as an indicator of climatic change: Examples from the Lahontan Basin. *Quatern. Res.* 32: 262–275.
- , D. R. Currey, R. I. Dorn, K. R. Lajoie, C. G. Oviatt, S. W. Robinson, G. I. Smith & S. Stine. 1990. Chronology of expansion and contraction of four Great Basin lake systems during the past 35,000 years. *Palaeogeogr. Palaeoclimatol. Palaeoecol.* 78: 241–286.
- Betancourt, J. L., C. Latorre, J. A. Rech, K. A. Rylander & J. Quade. 2000. A 22,000-year record of monsoonal precipitation from northern Chile's Atacama Desert. *Science* 289: 1542–1546.
- Blodgett, T. A., J. D. Lenters & B. L. Isacks. 1997. Constraints on the origin of paleolake expansions in the central Andes. *Earth Interact. J.* 1: 1–28, <<http://ams.allenpress.com/amsonline/?request-get-archive&issn-1087-3562>>, accessed 7 May 2009.
- Bobst, A. L., T. K. Lowenstein, T. E. Jordan, L. V. Godfrey, M. C. Hein, T.-L. Ku & S. Luo. 2001. A 106 ka paleoclimate record from drill core of the Salar de Atacama, northern Chile. *Palaeogeogr. Palaeoclimatol. Palaeoecol.* 173: 21–42.
- Clift, P. D. & A. J. Hartley. 2007. Slow rates of subduction erosion and coastal underplating. *Geology* 35: 503–506.
- Cortés, A., J. R. Rau, E. Miranda & J. E. Jiménez. 2002. Hábitos alimenticios de *Lagidium viscacia* y *Abrocoma cinerea*: Roedores sintópicos en ambientes altoandinos del norte de Chile. *Revista Chilena Hist. Nat.* 75: 583–593.
- Curry, D. R. & C. G. Oviatt. 1985. Duration, average rates, and probable causes of Lake Bonneville expansions, stillstands, and contractions during the last deep-lake cycle, 32,000 to 10,000 years ago. Pp. 9–24 in P. A. Kay & H. F. Diaz (editors), *Problems of and Prospects for Predicting Great Salt Lake Levels*. University of Utah Center for Public Affairs and Administration, Salt Lake City.
- Dillon, M. O. & P. W. Rundel. 1990. The botanical response of the Atacama and Peruvian desert floras to the 1982–83 El Niño event. Pp. 487–504 in P. W. Glynn (editor), *Global Ecological Consequences of the 1982–83 El Niño–Southern Oscillation*. Elsevier, Amsterdam.
- Dunai, T. J., G. A. González López & J. Juez-Larré. 2005. Oligocene-Miocene age of aridity in the Atacama Desert revealed by exposure dating of erosion-sensitive landforms. *Geology* 33: 321–324.
- English, N. B., D. L. Dettman, D. R. Sandquist & D. G. Williams. 2007. Annual and sub-annual variations of $\delta^{18}\text{O}$, $\delta^{13}\text{C}$ and F^{14}C in the spines of a columnar cactus, *Carnegiea gigantea*. *Oecologia* 154: 247–258.
- Evans, M. N. & D. P. Schrag. 2004. A stable isotope-based approach to tropical dendroclimatology. *Geochim. Cosmochim. Acta* 68: 3295–3305.
- Fritz, S. C., P. A. Baker, T. K. Lowenstein, G. O. Seltzer, C. A. Rigsby, G. S. Dwyer, P. M. Tapia, K. K. Arnold, T.-L. Ku & S. Luo. 2004. Hydrologic variation during the last 170,000 years in the southern hemisphere tropics of South America. *Quatern. Res.* 61: 95–104.
- Garreaud, R. D. & P. Aceituno. 2001. Interannual rainfall variability over the South American Altiplano. *Monthly Weath. Rev.* 125: 3157–3171.
- , M. Vuille & A. C. Clement. 2003. The climate of the Altiplano: Observed current conditions and mechanisms of past changes. *Palaeogeogr. Palaeoclimatol. Palaeoecol.* 194: 5–22.
- Garziona, C. N., P. Molnar, J. C. Libarkin & B. J. MacFadden. 2006. Rapid late Miocene rise of the Bolivian Altiplano: Evidence for removal of mantle lithosphere. *Earth Planet. Sci. Lett.* 241: 543–556.
- Ghosh, P., C. N. Garziona & J. M. Eiler. 2006. Rapid uplift of the Altiplano revealed through ^{13}C - ^{18}O bonds in paleosol carbonates. *Science* 311: 511–515.
- Grosjean, M., L. Núñez, I. Cartajena & B. Messerli. 1997. Mid-Holocene climate and culture change in the Atacama Desert, northern Chile. *Quatern. Res.* 48: 239–246.
- , ——— & ———. 2005. Palaeoindian occupation of the Atacama Desert, northern Chile. *J. Quatern. Sci.* 20: 643–653.
- Harris, S. E. & A. C. Mix. 1999. Pleistocene precipitation balance in the Amazon Basin recorded in deep sea sediments. *Quatern. Res.* 51: 14–26.
- Hartley, A. J. & G. Chong. 2002. Late Pliocene age for the Atacama Desert: Implications for the desertification of western South America. *Geology* 30: 43–46.
- , ———, J. Houston & A. E. Mathers. 2005. 150 million years of climatic stability: Evidence from the Atacama Desert, northern Chile. *J. Geol. Soc. London* 162: 421–424.
- Hoke, G. D., B. L. Isacks, T. E. Jordan & J. S. Yu. 2006. Groundwater-sapping origin for the giant quebradas of northern Chile. *Geology* 32: 605–608.
- Houston, J. & A. J. Hartley. 2003. The Central Andean west slope rainshadow and its potential contribution to the origin of hyperaridity in the Atacama Desert. *Int. J. Climatol.* 23: 1453–1464.
- Ibaraki, M. 1997. Closing of the Central American Seaway and Neogene coastal upwelling along the Pacific coast of South America. *Tectonophysics* 281: 99–104.
- Keller, G., T. Adatte, C. Hollis, M. Ordonez, I. Zambrano, N. Jimenez, W. Stinnesbeck, A. Aleman & W. Hale-Erlich. 1997. The Cretaceous/Tertiary boundary event in Ecuador: Reduced biotic effects due to eastern boundary current setting. *Mar. Micropaleontol.* 31: 97–133.
- Kober, F., S. Ivy-Ochs, F. Schlunegger, H. Baur, P. W. Kubik & R. Wieler. 2007. Denudation rates and a topography-driven rainfall threshold in northern Chile: Multiple cosmogenic nuclide data and sediment yield budgets. *Geomorphology* 83: 97–120.
- Lal, D. 1991. Cosmic-ray labeling of erosion surfaces: In situ nuclide production-rates and erosion models. *Earth Planet. Sci. Lett.* 104: 424–439.
- Lamb, S. & P. Davis. 2003. Cenozoic climate change as a possible cause for the rise of the Andes. *Nature* 425: 792–797.
- Laskar, J. 1990. The chaotic motion of the solar system: A numerical estimate of the chaotic zones. *Icarus* 88: 266–291.
- Latorre, C., J. L. Betancourt, K. A. Rylander & J. Quade. 2002. Vegetation invasions into Absolute Desert: A 45,000-yr rodent midden record from the Calama–Salar de Atacama Basins, northern Chile (22–24°S). *Bull. Geol. Soc. Amer.* 114: 349–366.

- , ———, ———, ——— & O. Matthei. 2003. A vegetation history from the arid prepuna of northern Chile (22–23°S) over the last 13,500 years. *Palaeogeogr. Palaeoclimatol. Palaeoecol.* 194: 223–246.
- , ———, J. A. Rech, J. Quade, C. Holmgren, C. Placzek, A. Maldonado, M. Vuille & K. A. Rylander. 2005. Late Quaternary history of the Atacama Desert. Pp. 73–90 in M. Smith & P. Hesse (editors), *23° S: The Archaeology and Environmental History of the Southern Deserts*. National Museum of Australia Press, Canberra.
- , ——— & M. T. K. Arroyo. 2006. Late Quaternary vegetation and climate history of a perennial river canyon in the Rio Salado basin (22°S) of northern Chile. *Quatern. Res.* 65: 450–466.
- Lenters, J. D. & K. H. Cook. 1997. On the origin of the Bolivian High and related circulation features of the South American climate. *J. Atmos. Sci.* 54: 656–677.
- Masek, J. G., B. L. Isacks, T. L. Gubbels & E. J. Fielding. 1994. Erosion and tectonics at the margins of continental plateaus. *J. Geophys. Res.* 99: 13941–13956.
- Molnar, P. & M. A. Cane. 2007. Early Pliocene (pre-Ice Age) El Niño-like global climate: Which El Niño? *Geosphere* 3: 337–365.
- Mourguiart, P. & M. P. Ledru. 2003. Last glacial maximum in an Andean cloud forest environment (Eastern Cordillera, Bolivia). *Geology* 31: 195–198.
- Nishiizumi, K., M. W. Caffee, R. C. Finkel, G. Brimhall & T. Mote. 2005. Remnants of a fossil alluvial fan landscape of Miocene age in the Atacama Desert of northern Chile using cosmogenic nuclide exposure age dating. *Earth Planet. Sci. Lett.* 237: 499–507.
- Palmer, M. R. & P. N. Pearson. 2003. A 23,000-year record of surface water pH and PCO_2 in the Western Equatorial Pacific Ocean. *Science* 300: 480–482.
- Petit, J. R., J. Jouzel, D. Raynaud, N. I. Barkov, J.-M. Barnola, I. Basile, J. Chappellaz, M. Davis, G. Delaygue, M. Delmotte, V. M. Kotlyakov, M. Legrand, V. Y. Lipenkov, C. Lorius, L. Pépin, C. Ritz, E. Saltzman & M. Stievenard. 1999. Climate and atmospheric history of the past 420,000 years from the Vostock ice core, Antarctica. *Nature* 399: 429–436.
- Placzek, C., J. Quade & P. J. Patchett. 2006a. Geochronology and stratigraphy of late Pleistocene lake cycles on the southern Bolivian Altiplano: Implications for causes of tropical climate change. *Bull. Geol. Soc. Amer.* 118: 515–532.
- , J. P. Patchett, J. Quade & J. D. M. Wagner. 2006b. Strategies for successful U-Th dating of paleolake carbonate deposits: An example from the Bolivian Altiplano. *Geochem. Geophys. Geosyst.* 7: Q05024.
- , A. Matmon, D. Granger, J. Quade & M. W. Caffee. 2007. Erosion rates in the Atacama Desert, northern Chile (24°S) from multiple cosmogenic nuclides. *Geological Society of America Abstracts with Programs* 39: 513.
- , S. Niedermann, D. E. Granger, A. Matmon & J. Quade. 2008. Cosmogenic ^{21}Ne , ^{10}Be and ^{26}Al in boulders from the central Atacama Desert, northern Chile. *Eos Trans. Am. Geophys. Union* 89(53), Fall Meet. Suppl., Abstract V53B-2152.
- , J. Quade, J. Rech, P. J. Patchett & C. Pérez de Arce. 2009. Geochemistry, chronology and stratigraphy of Neogene tuffs of the Central Andean region. *Quatern. Geochronol.* 4: 22–36.
- Quade, J., J. A. Rech, J. L. Betancourt, C. Latorre & T. Fisher. 2008. Paleowetlands and regional climate change in the central Atacama Desert, northern Chile. *Quatern. Res.* 69: 343–360.
- Rech, J., J. Quade & J. L. Betancourt. 2002. Late Quaternary paleohydrology of the central Atacama Desert (22–24°S), Chile. *Bull. Geol. Soc. Amer.* 114: 334–348.
- , J. S. Pigati, J. Quade & J. L. Betancourt. 2003. Re-evaluation of mid-Holocene wetland deposits at Quebrada Puripica, northern Chile. *Palaeogeogr. Palaeoclimatol. Palaeoecol.* 194: 207–222.
- , B. S. Currie, G. Michalski & A. M. Cowan. 2006. Neogene climate change and uplift in the Atacama Desert, Chile. *Geology* 34: 761–764.
- Roche, M. A., J. Bourges, J. Cortes & R. Mattos. 1992. Climatology and hydrology of the Lake Titicaca Basin. Pp. 63–88 in C. Dejoux & A. Iltis (editors), *Lake Titicaca: A Synthesis of Limnological Knowledge*. Kluwer Academic Publishers, Dordrecht.
- Rowe, H. D., R. B. Dunbar, D. A. Mucciarone, G. O. Seltzer, P. A. Baker & S. Fritz. 2002. Insolation, moisture balance and climate change on the South American Altiplano since the Last Glacial Maximum. *Climatic Change* 52: 175–199.
- Salinas, M. E. & C. Latorre. 2007. Un Estudio Tafonómico sobre la Representatividad de la Diversidad de Especies Vegetales en Paleomadrigueras de Roedores del Norte de Chile. *Resúmenes de la III Reunión Binacional de Ecología, La Serena, Chile*.
- Sillitoe, R. H. & E. H. McKee. 1996. Age of supergene oxidation and enrichment in the Chilean porphyry copper province. *Econ. Geol.* 91: 164–179.
- Vuille, M. 1999. Atmospheric circulation over the Bolivian Altiplano during dry and wet periods and extreme phases of the Southern Oscillation. *Int. J. Climatol.* 19: 1579–1600.
- & C. Ammann. 1997. Regional snowfall patterns in the high, arid Andes. *Climatic Change* 36: 413–423.
- & F. Keimig. 2004. Interannual variability of summertime convective cloudiness and precipitation in the central Andes derived from ISCCP-B3 data. *J. Clim.* 17: 3334–3348.
- , D. R. Hardy, C. Braun, F. Keimig & R. S. Bradley. 1998. Atmospheric circulation anomalies associated with 1996/1997 summer precipitation events on Sajama ice cap, Bolivia. *J. Geophys. Res.* 103: 11191–11204.
- Zhou, J. & K.-M. Lau. 1998. Does a monsoon climate exist over South America? *J. Clim.* 11: 1020–1040.

DIVERSIFICATION OF THE SOUTH AMERICAN AVIFAUNA: PATTERNS AND IMPLICATIONS FOR CONSERVATION IN THE ANDES¹

Jon Fjeldså² and Martin Irestedt³

ABSTRACT

By combining distributions and phylogenies for large groups of birds, it is now possible to disentangle the relative roles of contemporary ecology and history in explaining the distribution of biodiversity on earth. In South America, avian lineages, which represent radiations during the warm parts of the Tertiary, are best represented in the tropical lowlands and Andean forelands. During the upper Tertiary, diversification was most intense in the tropical Andes region, with recruitment back into the tropical lowlands and into South America's open biomes. Within the tropical Andes, endemism (mean inverse range size) and mean branch length (number of phylogenetic nodes on lineages) increase from the foothills up to the tree line and then decline again in the barren highlands, suggesting that the tree-line zone plays a special role in the diversification process. The resulting endemism is locally aggregated, often with marked peaks in areas immediately adjacent to ancient population centers. Thus, the process of evolution of new species is linked with local factors that, over a shorter time perspective, were also favorable for people. If we want to maintain the process of diversification, it becomes essential to supplement the traditional approach of preserving biodiversity in wilderness areas with few people with efforts to support sustainable development in populated areas.

Key words: Biodiversity, birds, conservation, South America, speciation.

The tropical Andes region is recognized as one of the principal global hotspots for biodiversity and conservation. Since the term "hotspot" was first launched (Myers, 1989, 1990), it has become a widely used buzzword, applied indiscriminately on different spatial scales, often combining species richness and endemism, although more critical data analysis reveals that spatial variation in species richness is often not congruent with endemism or with the occurrence of threatened species (Orme et al., 2005). Because different measures of biodiversity are idiosyncratic, we cannot use them blindly as a "currency of biodiversity."

Significant strides have been made to analyze to what extent the geographical variation in biodiversity measures reflects ecology, such as contemporary climate and landscape complexity. Ecological models perform quite well in explaining species richness, but closer examination reveals that the results are driven by the many data points representing widespread species, and that the models do not explain local aggregates of species with small distributions, which may instead reflect speciation history (Jetz et al.,

2004; Rahbek et al., 2006). With the rapid increase in DNA-based phylogenies, it is now possible to begin to link together the macroecological and historical approaches to biogeography (Fjeldså & Rahbek, 2006; Hawkins et al., 2006; Fjeldså et al., 2007b).

In this paper, we will illustrate how one can analyze large amounts of phylogenetic and distributional data to describe historical components of biodiversity patterns. We will also discuss the relative roles of past history and present ecology in explaining the Andean biodiversity hotspot. To place the Andes in a regional context, we will first take a continent-wide overview and then scale down to examine the hot points within the Andean hotspot. Based on interpretations of distinctive patterns of endemism in the Andes, we will finally discuss where to focus conservation actions.

MATERIALS AND METHODS

We will base this analysis on bird data. Birds are not perfect indicators of wholesale biodiversity (see

¹ P. Williams kindly provided the WORLDMAP software to manage the distributional data and to generate Figures 1–4. The databases were developed over more than 10 years through collaboration with numerous institutions and individuals. In addition to the sources listed in earlier populations, we used online databases at Yale University and University of California, Berkeley, and scrutinized maps by S. Herzog, whom we also thank for his assistance with compiling data on elevational distributions of birds in the Carrasco National Park in Bolivia.

² Zoological Museum, Universitetsparken 15, DK-2100 Copenhagen, Denmark. fjeldsaa@snm.ku.dk.

³ Molecular Systematics Laboratory, Swedish Museum of Natural History, P.O. Box 5007, SE-104 05 Stockholm, Sweden. doi: 10.3417/2007148

Moore et al., 2003) but are useful in terms of the quality of the available data. The species-level taxonomy is more or less complete, and for most avian groups there are now relatively detailed molecular phylogenies available. Furthermore, enough is known about species distributions to make fairly realistic distribution maps.

DISTRIBUTIONAL DATA

We used two databases of South American bird distributions digitized in the WORLDMAP software (Williams, 1998) based on extensive review of museum collections and literature and comprehensive fieldwork by the first author in the Andes region (see primarily Fjeldså & Krabbe, 1990). These databases are (1) a continent-wide database over all resident birds in a geographical grid of 1×1 geographical degrees described, e.g., by Fjeldså and Rahbek (1998) and Rahbek et al. (2006); and (2) a database over the tropical Andes region, in a grid of 15×15 geographical minutes (see Fjeldså et al., 1999, 2005a). The latter is the most finely resolved data set of its kind for the Andes. Such high resolution can only be obtained in highly structured landscapes, so this database includes only species that breed at elevations higher than 2500 m (at least in some parts of their ranges), plus lowland species representing the 25% of South American birds with the most restricted geographical ranges. This database contains 300,000 in-grid-cell records, of which 87,000 are confirmed present in a grid cell; the rest represents conservative interpolation in which careful scrutiny of topographic maps and satellite images, including Google Earth (<http://earth.google.com/>), suggests that the species should be present between collecting points. The interpolation is mostly used for species that are generally widespread or ubiquitous (and therefore are rarely reported). For species considered to be rare or local, the use of interpolation is restrictive.

For each grid cell, species richness is defined as the number of species (as accepted by the American Ornithologists' Union) and endemism is defined as range-size rarity, which is the inverse range size (number of grid cells in the species' range). This can be expressed as a mean value per species represented in a cell (mean endemism) or as a sum of inverse range-size scores.

To illustrate variation at the local scale, we used bird data from the Yungas of Cochabamba, Bolivia. It is a local hot point at 16°S , where the species richness is almost as high as near the equator (98.5% compared with the average of four grid cells representing humid Andean slopes adjacent to the equator). The data are based on several ornithological

surveys taken between 1991 and 2000 along three elevational transects in the Carrasco National Park (western, central, and eastern parts), from the lowlands over the top ridge of the Tunari Range at ca. 4000 m and into the adjacent rain shadow in the Cochabamba Basin. Because of undersampling in coca-growing areas in the foothills and in some very steep areas at mid-elevation, we found it appropriate to use interpolation to connect species records at different elevations along transects. We also added a few species based on historical records (mainly of widespread but rare species). In addition to the variation in species richness, we examined the variation in range-size rarity (endemism), as calculated from the continent-wide database.

HISTORICAL DATA

The study of avian evolution by Sibley and Ahlquist (1990) has, despite serious problems with their method of molecular phenetics based on DNA-DNA hybridization, already served as a basis for describing the general pattern of accumulation of ancient taxa in the tropical lowland rainforests and more recent diversification in montane areas near the equator and at high latitudes (Fjeldså, 1995; Hawkins et al., 2006).

Today, better data based on DNA sequences are available. We obtained phylogenetic data by literature review and through research collaboration, primarily between the institutions of the two authors, where we aim to generate global molecular phylogenies for the largest avian radiation, the passerine birds (order Passeriformes). We will present geographical distribution patterns for some clades defined through molecular phylogenetic studies, including the historical diversification of the suboscine family Furnariidae (Fjeldså et al., 2005b, 2007b; Irestedt et al., 2006, unpublished data). This family was chosen as an example because it is endemic and diverse (302 species) and has adapted to all terrestrial environments in the continent and is a prominent component of the avifauna of even the harshest environments (Remsen, 2003). Only 60% of the furnariid species have so far been included in molecular phylogenies, but the deeper branches are well resolved, and the sampling gaps in the terminal parts of the phylogeny can therefore be reasonably filled using published judgments about relationships within these subgroups. In some terminal branches with many closely related species, which are left unresolved, branch lengths were assigned to each species by assuming a regular spacing of nodes (thus, a trichotomy translates into 1.6 steps: four species in a clade represent two steps; eight species, three steps; 16 species, four steps, etc.).

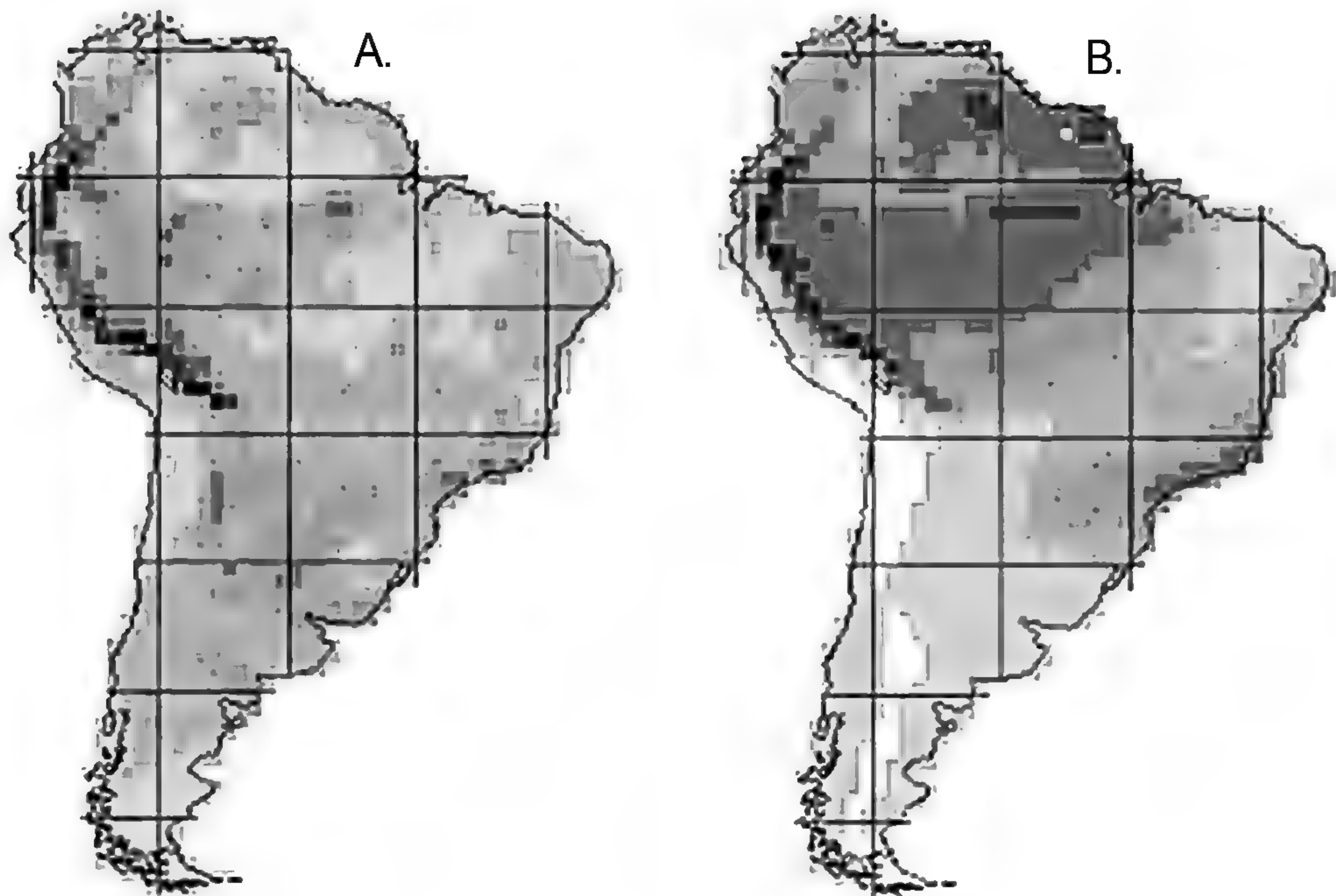

Figure 1. Species richness patterns for ancient avian groups in South America. —A. Sixty-five species representing small avian clades (of one to four species) dating back to the Eocene or before (as judged from molecular evidence). —B. The deep branches of New World flycatchers, altogether 248 species representing Cotingidae, Pipridae, Tityrinae, pipromorphines, and some small clades, all of which had their origin in the Oligocene (Ohlson et al., 2008). Species richness is represented from greatest (black cells) to least (white cells).

Because a chronogram with local calibration points is not yet published for the Furnariidae family, we analyzed the diversification of the group by giving each species a branch-length score, which is the number of nodes to the root of the phylogeny. For a simple illustration, we divided the species into quartiles of branch lengths, with the first quartile being the 25% of the species representing the fewest apparent splitting events since the origin of the group and the fourth quartile being the 25% of the species representing the most splitting events.

RESULTS

VARIATION IN SPECIES RICHNESS IN SPACE AND TIME

By reviewing the published molecular evidence of avian evolutionary relationships, we identified 65 species representing small clades (of one to four species) dating back to the Eocene or even earlier (e.g., rheas, Rheidae; screamers, Anhimidae; hoazin, *Opisthocomus hoazin*; broad-billed Sapayoa, *Sapayoa aenigma*). These species represent lineages in which there was little or no subsequent speciation, or where such events had been erased by extinction (Ricklefs, 2003); we see them here as surviving representatives

of the endemic South American avifauna of the Early Tertiary climatic maximum. As illustrated in Figure 1A, these species are today mainly found in the tropics outside the Andes, and to some extent in the subtropics, with peak concentrations in dynamic floodplains with mosaics of swampy and savanna habitats (Sucumbíos/Napo/Pastaza in Ecuador; Loreto and locally near Pucallpa and Madre de Dios, Peru; Bolivian savannas and adjacent Pantanal; the middle reaches of the Amazon River of Pará and savanna mosaics of Amapá, Brazil; Cuyuni–Mazaruni in Guyana). This richness pattern is almost identical to that of the 25% most widespread South American birds, which was found to be best explained from ecosystem productivity (Rahbek et al., 2006). The only difference is a slightly higher representation of ancient species in the hydrologically unstable Chaco.

Our next examples are from the largest endemic South American avian radiation of suboscine passerine birds (more than 1100 species), which is now subject to detailed phylogenetic study (Irestedt et al., 2002, 2004, 2006; Fjeldså et al., 2007a; Tello & Bates, 2007; Ohlson et al., 2008). The early (Middle Tertiary) suboscine radiations (antbirds and gnatcatchers in the tracheophone radiation and cotingas, manakins, tityrines, and pipromorphines in the New

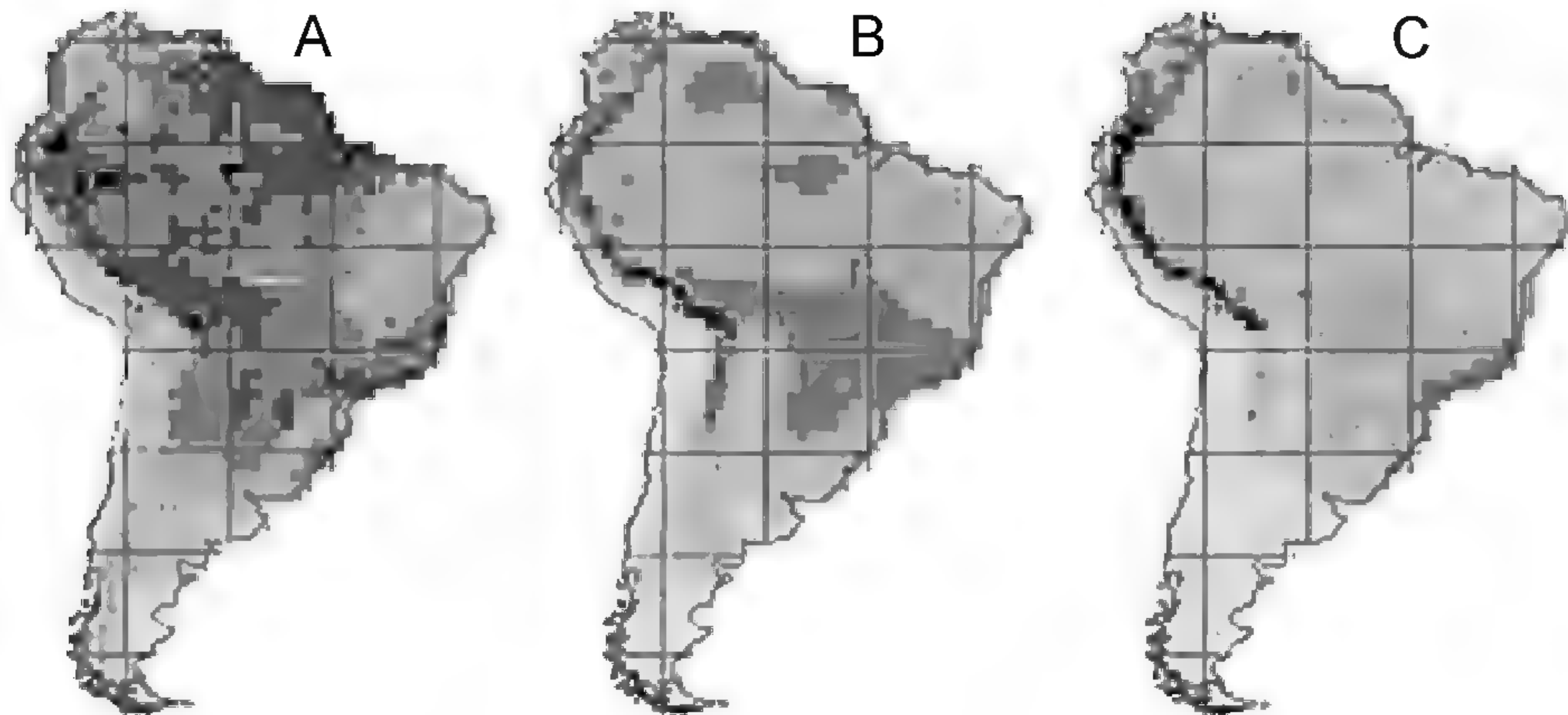

Figure 2. Comparison of species richness patterns for three clades that all diversified after the early Miocene. —A. Core ovenbirds, Furnariinae (Irestedt et al., 2006). —B. New World flycatchers, Tyrannidae (Ohlson et al., 2008). —C. Tanagers, Thraupidae (Jønsson & Fjeldså, 2006). A and B represent ancient South American lineages; C is part of a larger group colonizing from North America. Species richness is represented from greatest (black cells) to least (white cells).

World flycatcher radiation) are all typical groups of the tropical lowland forests. Because a long branch separates the early radiations of New World flycatchers from Neogene radiation (Tyrannidae s. str.) (Ohlson et al., 2008), we present these early flycatcher clades in a map (248 species, Fig. 1B) that illustrates the species richness pattern of a group whose diversification started during the Oligocene and continued to diversify in the same (forest) habitat. The species richness is high throughout the humid tropical forest biomes, with the peak concentration of species in Ecuador and Peru on the transition from the Amazon lowlands toward the Andes.

We illustrate the species richness pattern of groups whose diversification started well into the Miocene, with three species-rich groups as examples; of these, the Furnariinae (core ovenbirds, Fig. 2A) and the Tyrannidae (s. str., Fig. 2B) are subclades of old South American groups, while the tanagers (Thraupidae, Fig. 2C) represent the large group of nine-primaried oscines that colonized from North America. These groups are more broadly distributed than the old groups, including those in the savanna biomes. In particular, all three have their peak concentration in the Andes. The similarity of patterns shows that the intensive radiation of a new taxonomic group in the Andes (Fjeldså & Rahbek, 2006) did not prevent the other two groups from diversifying in this same area. The tropical Andes region stands out clearly as the center of avian diversification during the Neogene.

To illustrate how diversification in an old South American group proceeded up through the Neogene, we subdivide the 302 furnariid species into quartiles of different branch lengths (Fig. 3). The first quartile of species (Fig. 3A), many of them in monotypic genera, represents lineages with low speciation rates

or past extinction filters and is mainly found in the forested tropics, notably in upper Amazonian terra firme forest and on the adjacent humid Andean slopes and the northern part of the Andes region, which was more or less isolated by marine transgressions in the early Neogene. The second quartile (Fig. 3B) gives a similar pattern, although with more species associated with areas that once comprised extensive swamp forests, mangroves, and palm savannas fringing marine incursions in the Amazon Basin. The more derived species (third and fourth branch-length quartiles, Fig. 3C, D) are particularly strongly represented in the grassland biomes of the La Plata and Río Negro basins and along the Andes, with the third quartile mainly in the dry-based southern and central Andean highlands and the most terminal branches (fourth quartile) concentrated in the tropical East Andean cloud-forest zone. We also note, in Figure 3D, that there is a certain spillover from the humid Andes to river island habitats along the main Amazonian river channels.

THE ANDEAN HOTSPOT AND ITS LOCAL HOT POINTS

The species richness pattern for range-restricted Andean highland birds (Fig. 4) shows marked hot points within the tropical Andean hotspot. This is less apparent in other studies of avian endemism in the Andes (e.g., Stattersfield et al., 1998), which simply outlined areas characterized by separate sets of species but paid less attention to their strongly aggregated (nested) distribution. Particularly strong aggregates of range-restricted species are found on the humid slopes in southern Chocó (Colombia), near the equator and where the East Andean cloud forest is deeply intersected by valleys (e.g., to either side of the

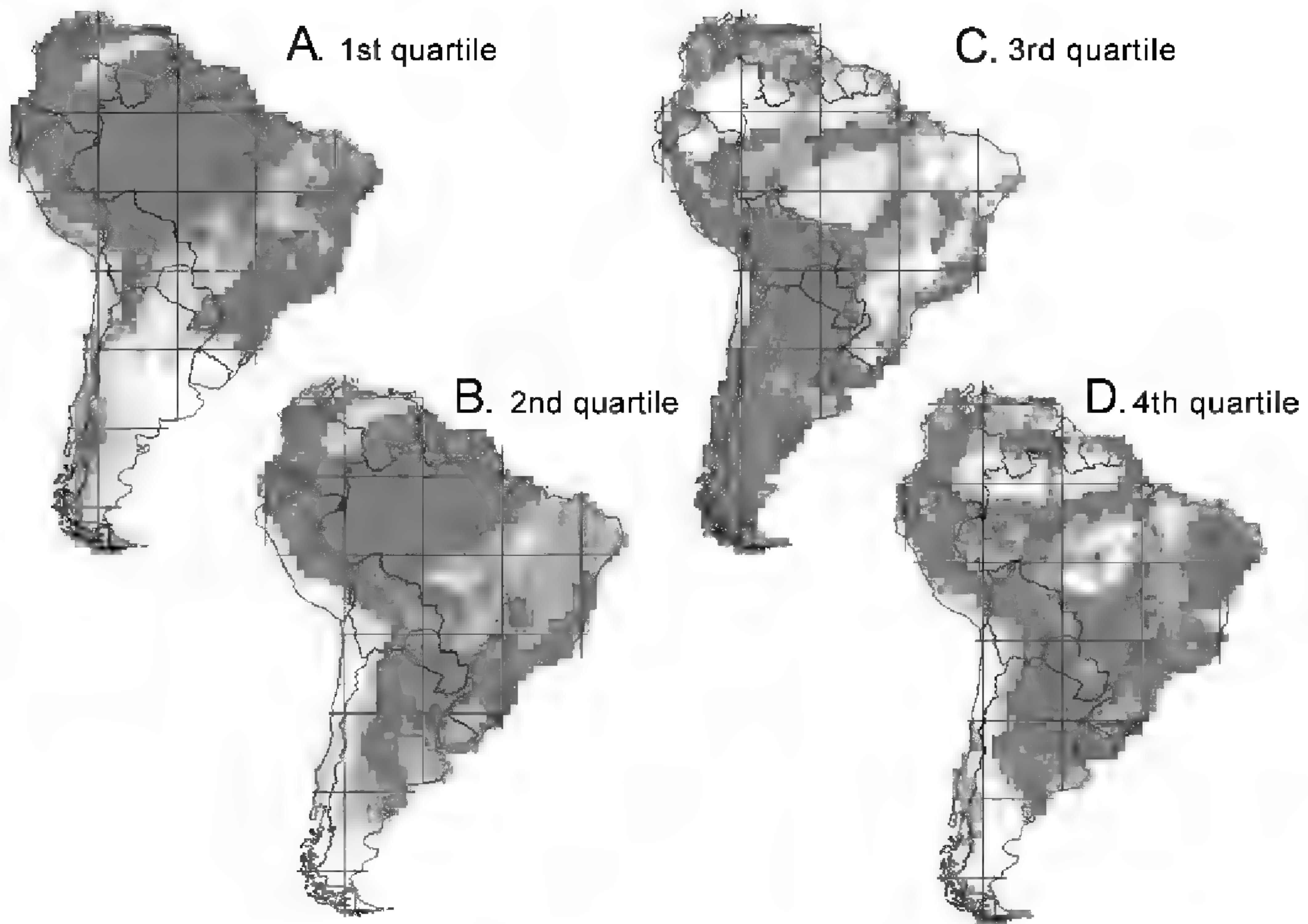

Figure 3. Species richness variation of Furnariidae (ovenbirds and woodcreepers) divided by branch-length quartiles, with the first quartile being the 25% of the species that are the fewest nodes away from the root of the phylogeny and the fourth being the 25% of the species representing the longest (terminal) branches. Red cells represent maximum species richness; white cells represent no species present.

North Peru Low, and in places where the eastern Andean ridge is deeply intersected by valleys in Huánuco and Cuzco [Peru] and southern La Paz [Bolivia]). Fairly high values are also found deeper into the Andes, where distinctive mist zones and cloud forest can be found on the transition between warm valleys and barren highlands (e.g., around the Magdalena Valley, Colombia, on the eastern slope of Cordillera Blanca; in Apurímac–Cuzco, Peru; and around the Cochabamba Basin, Bolivia). Many of the endemic species in these areas are associated with environments near the tree line and with relict patches of high-altitude woodland deeper into the highland.

Typically, the most closely related species inhabit corresponding elevation zones on adjacent slopes (in some cases replacing each other sharply even if there is no obvious barrier), while species replacing each other in different elevation zones on the same slopes (see Krabbe & Schulenberg, 1997) are often more distantly related (review in García-Moreno & Fjeldså, 1999).

THE VARIATION IN AVIAN DIVERSITY ON AN ANDEAN ELEVATIONAL GRADIENT

The local variation in biodiversity parameters within an Andean hot point is illustrated in Figure 5.

This elevational transect, from the lowlands up to the ridge of the Cordillera Tunari and over into the rain shadow area in the Cochabamba Basin, has altogether 731 species of birds: 668 recorded on the humid slope and 123 on the slopes of the adjacent rain shadow basin. The species richness curve (full line in Fig. 5) suggests a maximum of 411 species around 500 m elevation and a gradual decline, following a concave curve up through the massively forested midslope to a relative plateau, or shoulder, corresponding to the habitat mosaics around the tree line. From here the species richness drops sharply up to the barren top ridge. In the rain shadow zone, the species richness is lower. The kind of pattern with a diversity peak on the lower slope seems typical of elevation gradients (Rahbek, 1995), although there is some variation between groups in the position of the diversity peak on the slope (Jørgensen & León-Yáñez, 1999; Kessler et al., 2001).

The endemism (mean range-size rarity per species, stippled line in Fig. 5) describes a different pattern, with very low levels (widespread species) at the base of the Andes and high levels in the montane forest. The peak is in the tree-line zone, which is at 3400 m in a few places without human impact but is mostly depressed to below 3000 m as a consequence of

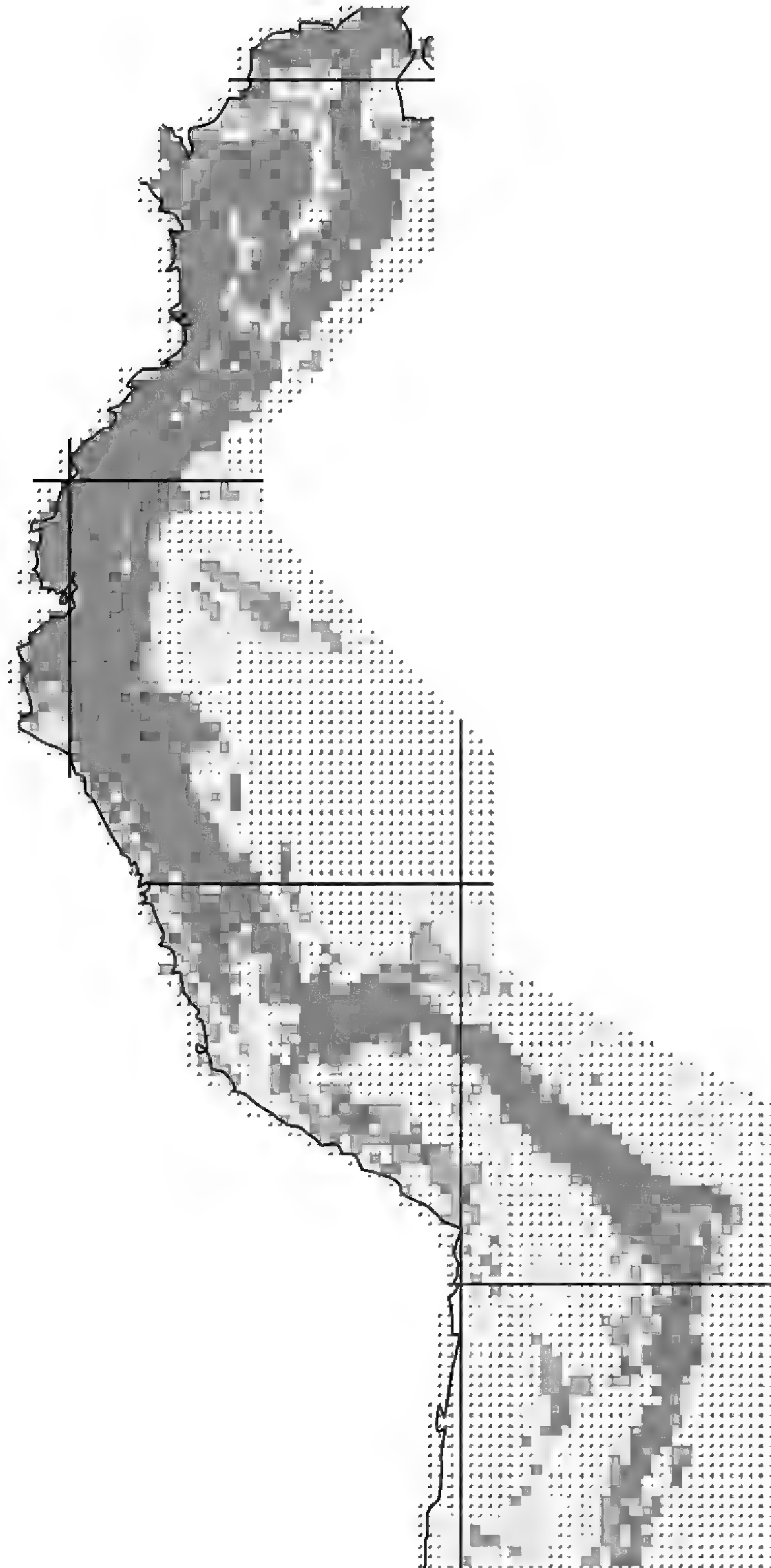

Figure 4. Species richness in the Andes ($15' \times 15'$ geographical grid) for 470 species representing the lower range-size quartile (25% of species with smallest distributions) of South American birds. Red cells represent maximum species richness; white cells represent no species present.

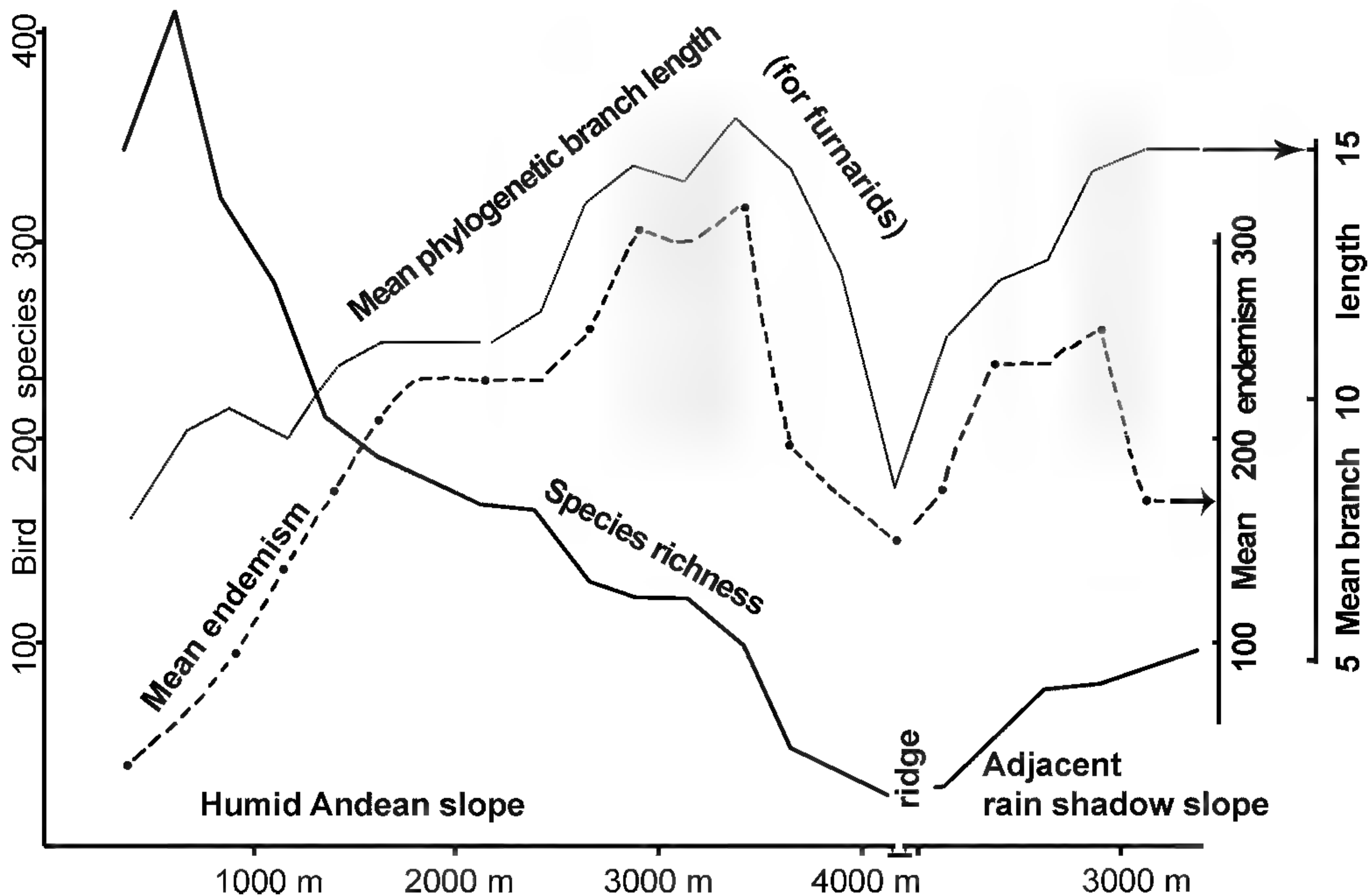

Figure 5. Species richness and endemism along an ecological gradient in the Andes: Carrasco National Park in Bolivia, from lowlands to the highest ridge of Cordillera Tunari and into the adjacent Cochabamba Basin. The tree-line zone, with patchy arboreal vegetation, is shaded. The graph is based on several field surveys between 1991 and 2000 (the first author and local survey results compiled by S. K. Herzog, unpublished data). To compensate for undersampling in coca areas in the foothills and on very steep terrain with difficult access on the midslope, we used interpolations based on historical records from the area and the known elevational limits of species. The index of endemism (stippled curve) is the average inverse range size (number of grid cells in the range of occupancy, as per the 1° distributional database); the branch length (thin line) is the average number of nodes on the phylogenetic branches of the represented furnariid species, based on phylogenies developed by the second author.

incessant burning to create fresh pasture (Kessler & Herzog, 1998). A high mean endemism is also found at 3000–3500 m in the adjacent rain shadow area, where tiny woodland patches can still be found in a highly degraded matrix of bushy habitats and bunchgrass.

To assess whether the high endemism score at the tree line is a simple consequence of the limited areas that are available or reflects a higher rate of speciation, we examined the variation in branch length (number of nodes from the root, for Furnariidae) along the elevational gradient (thin line in Fig. 5). Species representing recent radiations are present both low and high. Nevertheless, the mean branch-length values produce a clear pattern with a predominance of deep branches in the foothills and terminal branches representing more recent radiations in the upper montane forest and on the transition toward the barren highland. Only 54 Furnariidae species were recorded along this gradient, and the sample size is particularly low (five species, with moderately long branches) at the barren top ridge. However, scrutiny of other large taxonomic groups

(with good, although not complete, phylogenetic data) suggests that the depicted curve may be fairly typical. Thus, the many range-restricted biological species and sharp spatial replacements (with very few reported cases of hybridization) in the tree-line zone reflect exceptionally high rates of completed speciation in this zone.

DISCUSSION

In agreement with other studies (e.g., Fjeldså, 1995; Hawkins et al., 2006), we found that the tropical lowland rainforest was dominated by species representing basal lineages with a history of little apparent diversification. Paleobotanical evidence suggests that a species richness comparable with contemporary tropical rainforests extended to Patagonia during the Eocene climatic optimum (Wilf et al., 2003), suggesting that the current diversity pattern is a consequence of range contraction and niche conservatism in old clades. Thus, extinction filters (e.g., during the rapid Eocene/Oligocene or Plio-Pleistocene cooling) may explain why these groups are now

mainly restricted to the tropics, but lack of opportunities for speciation in featureless lowlands may, of course, also play a role. The densest concentrations of widespread species (Rahbek et al., 2006: fig. 1e) and ancient relictual taxa (Fig. 1A) are found in flat and swampy landscapes, the distribution of which has shifted much in geological time as a consequence of changes in drainage pattern and marine incursions (Albert et al., 2006) and rapid sedimentation cycles. We must therefore assume that these species persisted by moving around and taking advantage of the patch dynamics and high productivity of the floodplains. Other rainforest groups continued to diversify, but mostly in terra firme forest, and with slow speciation rates overall.

Species with small distributions follow other geographical patterns, with remarkable aggregates in topographically structured parts of the tropics (Orme et al., 2005; Hawkins et al., 2006; Rahbek et al., 2006). Because of a lack of a well-calibrated local molecular clock, our present attempts to link distributions and evolutionary history are imperfect; we still have to use node numbers as a relative measure of recency of speciation. Yet our data provide strong evidence of high rates of speciation in areas of high endemism, both on the large scale (Fig. 3) and on the elevation gradient in the Andes (Fig. 5).

The strong radiation of tanagers (and other colonists from North America) in the Andes did not seem to constrain the rate of radiation on the old endemic South American groups (Fig. 2). Similar patterns of endemism in other well-charted groups (e.g., wild potatoes, Hijmans & Spooner, 2001) support the existence of local centers of intensive speciation in the Andes. Speciation is followed by redistribution and establishment of dense niche packing, for instance on elevation gradients (García-Moreno & Fjeldså, 1999), which means that the ecosystem is accruing more and more species.

Some students of lowland faunas may object to this simple picture and claim that the use of a broad biological species concept in ornithology underestimates the degree of differentiation of the Amazonian avifauna. The variation in mitochondrial DNA of some widespread South American birds suggests distinct evolutionary entities (e.g., Joseph et al., 2001; Lovette, 2004), but it is still unclear to what extent these geographical populations represent species, or whether the results reflect the pattern of sampling or an unusual evolutionary behavior of mitochondrial DNA and the influence of selective sweeps (e.g., Bazin et al., 2006). Admittedly, some widespread lowland species should be split into component phylogenetic species, but a full revision of the South American avifauna would certainly also reveal a need for

splitting Andean species. It is unlikely that such a revision would alter the overall pattern.

Intensive speciation in mountains is found only at low latitudes (Rahbek et al., 2006; Hawkins & Diniz-Filho, 2006; Storch et al., 2006; Weir, 2006; Davies et al., 2007). Even at the moderate latitude of 27°N–31°N in the Himalayas, species richness is mainly built up by colonization from outside rather than by local differentiation (Johansson et al., 2007). At high latitudes, similar broad distributions are found in mountainous and flat areas (Hawkins & Diniz-Filho, 2006). Low seasonality in the tropics means reduced seasonal overlap in thermal regimes between low- and high-altitude sites, which is why the individual species could adapt to local conditions (Chalambor et al., 2006). This leads to dense altitudinal stacking of species (Krabbe & Schulenberg, 1997; García-Moreno & Fjeldså, 1999) and complex patterns of endemism (vicariance, leading to added diversity on coarse-scale geographical analyses; Rahbek & Graves, 2001), in contrast to the wide distributions on high latitudes—even for highland birds (Weir, 2006).

A pertinent question now is whether speciation in the Andes (or other tropical mountains; Fjeldså et al., 2007b) is (1) a specific Plio-Pleistocene phenomenon or (2) a general tendency for diversification to start in topographically structured landscapes but being followed by redistribution as climate-driven range dynamics gradually push the species diversity toward the lowlands, leading to the general correlation with available energy, water, and area (Storch et al., 2006). Figure 3D seems to indicate a spread of furnariids from the Andes along the Amazon (see García-Moreno et al., 1999, for a case of an Andean radiation leading to colonization of Amazonian river island habitats). Similarly, the large radiation of *Tangara* Brisson in South American rainforests started in the Andes (Burns & Naoki, 2004). The furnariid genus *Cinclodes* G. R. Gray, which radiated in the barren Andean highlands, gave rise to two independent colonizations (with speciation) of coastal habitats (Chesser, 2004). Yet, the evidence for montane areas acting as species pumps is still scant, and well-resolved phylogenies of species-rich groups are needed to fully evaluate this interpretation.

FACTORS DRIVING THE DIVERSIFICATION PROCESS

Traditionally, speciation in the Andes has been explained as vicariance (involving observed or hypothesized past barriers; e.g., Vuilleumier, 1980; Jørgensen et al., 1995). Weir (2006) suggests that the intense Pleistocene speciation in tropical mountains could be a result of the marked dispersal barriers

created by glaciers and severe elevation shifts of montane vegetation zones in connection with Pleistocene glacial cycles. Weir's analysis may have been biased by the fact that most of the molecular phylogenies he used covered species-rich genera, and he overlooked the fact that many birds of the barren puna are widespread and represent small or even monotypic genera, suggesting that the range dynamics caused by glacial cycles may erase historical population structure rather than promote differentiation (see Jansson & Dynesius, 2002).

Figure 5 suggests that the highest incidence of speciation was around the tree line. Graves (1985, 1988) documented that the highest degree of population differentiation in birds was at the tree line, and he linked this with the high risks of random extinction of local populations within this very narrow habitat band. It should be emphasized here that the tree-line zone is mostly 1 km wide but extends along more than 4000 km. We may not need glaciers to break up the populations of birds in such a habitat band. General environmental instability is enough to lead to relict distributions of some lineages, and thus inevitable divergence of remnant populations by genetic drift.

To understand the mechanisms of speciation, we should perhaps focus less on physical barriers and more on local conditions that allow local source populations to persist despite global climate instability. This could, in turn, allow the development of complex and co-adapted biological communities in places with a benign local climate (as opposed to highlands, where communities change incessantly as a consequence of range dynamics caused by climate change). Fjeldså et al. (1999) demonstrated that peak concentrations of endemic birds at the East Andean tree line correlate with low interannual variation in ground-level climatic conditions, as documented by long series of satellite images. Unfortunately, remotely sensed data of montane habitats are difficult to analyze, and climate models (based on interpolation of data from an insufficient network of weather stations) are far too crude to identify special local environments, such as persistent mist zones on the transition between warm valleys and cold high plateaus. A geographical correspondence between peak values of young endemic species and older relictual forms in the Andes (Fjeldså, 1995) provides indirect evidence for linking speciation with local persistence in stable environments. Still, a thorough evaluation must await detailed analysis of historical population structures, but a sufficiently dense sampling is still lacking for Andean birds (see Bowie et al., 2005, for Afromontane birds, however).

In this context it is interesting to note that high levels of endemism in the Andes correspond (with strong statistical support using data from well-sampled sites only) with ancient cultural centers in the Andes (e.g., Tomebamba [Cuenca], Chavín, Ayacucho–Cuzco, Cochabamba) (Fjeldså, 2007). A positive correlation between biodiversity and population is well known at coarse geographical scales (e.g., Cincotta et al., 2000; Balmford et al., 2001; Araújo, 2003; van Rensburg et al., 2004; Luck, 2007), but the Andean study is on a finer scale (15' × 15'), and it is interesting to note that the biodiversity/population relationship is stronger for pre-Colombian population centers than for present population patterns, which may be more influenced by external drivers.

The simplest explanation would be that special local conditions in some Andean valleys governed geographical patterns of persistence of bird populations as well as patterns of population growth, albeit at different timescales (Fjeldså, 2007). It is possible that the local conditions that stimulated development of rich (and perhaps co-adapted) biological communities (and thus the cladogenetic process, see Jetz et al., 2004; Rahbek et al., 2006) may also have meant crop predictability. This may, in turn, have been a major prerequisite for the transition from hunter-gatherers to resident farming systems, and for the further advancement of agriculture and development of agricultural centers in certain mountain basins, such as Tomebamba, Cochabamba, and the Ayacucho Valley (Fjeldså et al., 1999; Fjeldså, 2007). The distinct altitudinal zonation (with distinct biological assemblies) may also have facilitated the vertical ecology so characteristic of Andean cultures, with specific crops in specific zones.

IMPLICATIONS FOR CONSERVATION

The effort to preserve biodiversity has traditionally focused on the wilderness; in other words, the unspoiled nature as concept (see Fjeldså, 2007). On a coarse spatial scale, the highest biodiversity in South America is found in the rainforests of the sub-Andean zone and on the humid Andean slopes that are relatively unaltered by humans due to their unsuitability for agriculture, grazing, and forestry (Ortiz, 1975; Young & León, 1999). Because the cloud-forest zone is universally accepted by planners to be inappropriate for large-scale colonization, many national parks were established here. Furthermore, the effect of a moderate disturbance by scattered small farms may not be very different from the patch dynamics caused by frequent landslides on these steep slopes. The conservation situation may only be critical in the Andean forelands and foothills, which

are subject to intensive exploitation, notably the growing of coca and uncontrolled logging in Peru (Stotz, 1998; Fjeldså et al., 2005a). This zone has the highest alpha diversity, but on the other hand most of the species are widespread and therefore likely to survive despite local habitat loss (Fig. 5).

Our results suggest that a conservation strategy focused on inaccessible tracts of Andean cloud forest will not be enough. If we are to succeed in slowing the loss of biodiversity, we also need actions where people live, in the montane valleys, and in the transition toward the cloud forest, where people graze their cattle. Here, the primary vegetation is almost nonexistent today (at least in Peru and Bolivia) because of a long history of pastoralism and the use of fire to renew pastures (Kessler & Herzog, 1998). Fortunately, many endemic birds persist remarkably well in small remaining woodlands, and range-restricted plants are also to a large extent associated with degraded habitat or small patches of special (azonal) habitat (Kessler, 1999).

Finding the right solutions requires, first, that we understand the processes underlying the observed patterns of biodiversity and human settlement. The idea of speciation through formation of persistent relict populations in stable local environments (as opposed to traditional focus on barriers) has significant implications. Notably this implies deterministic processes and development of functional assemblages of organisms that may, in turn, mold the ecological processes (Daily, 1997). One of the most prominent ecosystem services provided by Andean biodiversity is the water supply from the elfin forests in specific misty places, situated exactly in the zones identified at hotspots for avian diversification. Such elfin forests represent a distinctive sclerophyllic vegetation type, often of complex structure and overloaded with epiphytes that develop on cloud-enshrouded slopes and that have the ability to comb water out of the mist. Once established, such forests affect the surrounding environment and the livelihood for people living in adjacent valleys (e.g., Campos & Calvo, 2000; Becker et al., 2005). During the past 15 years, a rapidly growing research field suggests that increased species richness may enhance ecosystem productivity, drought resistance, and resilience (e.g., Kinzig et al., 2001). Although this evidence is still mostly based on small experimental plots, the perspective seems highly relevant in relation to the management of those parts of the Andean highland, which now appear as overgrazed bunchgrass steppe.

If the correlation between population and biodiversity in the Andes is more than just two independent effects of suitable environmental settings (Luck, 2007) and if functional links exist (biodiversity enhancing

livelihood for people), then we have a potential win-win situation for biodiversity conservation and development. However, in order for this to be realized, conservationists, developers, and local communities must come to terms; biologists must provide precise advice about how nature can help people achieve a better life; and politicians must be willing to pay the cost of setting aside essential tracts of land and support innovative development for higher production on some parts of the land (Green et al., 2005).

Unfortunately, the discussion about where to focus conservation efforts is full of rhetoric of little scientific value when organizations focus on funding points (e.g., for the Andean Dispersal Corridor, or before that for the “green lungs” of the Amazon rainforest). In this context, the small pockets of remaining tree-line habitat in the Andes have been rejected as “the living dead” and therefore not worth saving (Ibisch et al., 2005: 84). We have tried to illustrate that these areas are indeed sites of important processes, both with respect to the diversification process and to suitable conditions for people. The promotion of conservation in these areas is outside the scope of our paper but nonetheless will benefit from insights developed from consideration of patterns of biodiversity and their underlying processes.

Literature Cited

- Albert, J. S., N. R. Lovejoy & W. G. R. Crampton. 2006. Miocene tectonism and the separation of cis- and trans-Andean river basins: Evidence from Neotropical fishes. *J. S. Amer. Earth Sci.* 21: 14–27.
- Araújo, M. B. 2003. The coincidence of people and biodiversity in Europe. *Global Ecol. Biogeogr.* 12: 5–12.
- Balmford, A., J. C. Moore, T. Brooks, N. Burgess, L. A. Hansen, P. Williams & C. Rahbek. 2001. Conservation conflicts across Africa. *Science* 291: 2616–2619.
- Bazin, E., S. Glémins & N. Galtier. 2006. Population size does not influence mitochondrial genetic diversity in animals. *Science* 312: 570–572.
- Becker, C. D., A. Agreda, E. Astudillo, M. Constantino & P. Torres. 2005. Community-based monitoring of fog capture and biodiversity at Loma Alta, Ecuador enhance social capital and institutional cooperation. *Biodivers. & Conservation* 14: 2695–2707.
- Bowie, R. C. K., J. Fjeldså, S. J. Hackett, J. M. Bates & T. M. Crowe. 2005. Coalescent models reveal the relative roles of dispersal, vicariance and ancestral polymorphism in shaping phylogeographical structure of an African montane forest robin. *Molec. Phylogen. Evol.* 38: 171–188.
- Burns, K. J. & K. Naoki. 2004. Molecular phylogenetics and biogeography of Neotropical tanagers in the genus *Tangara*. *Molec. Phylogen. Evol.* 8: 334–348.
- Campos, J. J. & J. C. Calvo. 2000. Compensation for environmental services from mountain forests. Pp. 26–27 in M. Agenda (editor), *Mountains of the World: Mountain Forest and Sustainable Development*. Mountain Forum, Bern.
- Chesser, R. T. 2004. Systematics, evolution, and biogeography of the South American ovenbird genus *Cinclodes*. *Auk* 121: 752–766.

- Cincotta, R. P., J. Wisnewski & R. Engelman. 2000. Human population in the biodiversity hotspots. *Nature* 404: 990–992.
- Daily, G. C. 1997. *Nature's Services—Societal Dependence on Natural Ecosystems*. Island Press, Washington, D.C.
- Davies, R. G., C. D. L. Orme, D. Storch, V. A. Olson, G. H. Thomas, S. G. Ross, T.-S. Ding, P. C. Rasmussen, P. M. Bennett, I. P. F. Owens, T. M. Blackburn & K. J. Gaston. 2007. Topography, energy and the global distribution of bird species richness. *Proc. Roy. Soc. London, Ser. B, Biol. Sci.* 274: 1189–1197.
- Fjeldså, J. 1995. Geographical patterns of neoendemic and older relict species of Andean forest birds: The significance of ecologically stable areas. Pp. 89–102 in S. P. Churchill, H. Balslev, E. Forero & J. L. Luteyn (editors), *Biodiversity and Conservation of Neotropical Montane Forests*. New York Botanical Garden, Bronx.
- . 2007. How broad-scale studies of patterns and processes can guide conservation planning in Africa. *Conserv. Biol.* 21: 659–667.
- & N. Krabbe. 1990. *Birds of the High Andes*. Zoological Museum, University of Copenhagen, and Apollo Books, Svendborg, Denmark.
- & C. Rahbek. 1998. Continent-wide conservation priorities and diversification processes. Pp. 139–160 in G. M. Mace, A. Balmford & J. R. Ginsberg (editors), *Conservation in a Changing World*. Cambridge University Press, Cambridge, United Kingdom.
- & ———. 2006. Diversification of tanagers, a species rich bird group, from lowlands to montane regions of South America. *Integr. Comp. Biol.* 46: 72–81.
- , E. Lambin & B. Mertens. 1999. Correlation between endemism and local ecoclimatic stability documented by comparing Andean bird distributions and remotely sensed land surface data. *Ecography* 22: 67–78.
- , M. D. Álvarez, J. M. Lazcano & B. León. 2005a. Illicit crops and armed conflict as constraints on biodiversity conservation in the Andes region. *Ambio* 34: 205–211.
- , M. Irestedt & P. G. P. Ericson. 2005b. Molecular data reveal some major adaptational shifts in the early evolution of the most diverse avian family, the Furnariidae. *J. Ornithol.* 146: 1–13.
- , ———, K. A. Jønsson, J. I. Ohlson & P. G. P. Ericson. 2007a. Phylogeny of the ovenbird genus *Upucerthia*: A case of independent adaptations for terrestrial life. *Zool. Scripta* 36: 133–141.
- , U. Johansson, L. G. S. Lokugalappatti & R. C. K. Bowie. 2007b. Diversification of African greenbuls in space and time: Linking ecological and historical processes. *J. Ornithol.* 148(Suppl. 2): 359–367.
- García-Moreno, J. & J. Fjeldså. 1999. Phylogeny and re-evaluation of species limits in the genus *Atlapetes* based on mtDNA sequence data. *Ibis* 141: 191–207.
- , J. P. Arctander & J. Fjeldså. 1999. A case of rapid diversification in the Neotropics: Phylogenetic relationships among *Cranioleuca* spinetails (Aves, Furnariidae). *Molec. Phylog. Evol.* 12: 273–281.
- Ghalambor, C. K., R. B. Huey, P. R. Martin, J. J. Tewksbury & G. Wang. 2006. Are mountain passes higher in the tropics? Janzen's hypothesis revisited. *Integr. Comp. Biol.* 46: 5–17.
- Graves, G. R. 1985. Elevational correlates of speciation and intraspecific geographic variation in plumage in Andean forest birds. *Auk* 102: 556–579.
- . 1988. Linearity of geographic range and its possible effect on the population structure of Andean birds. *Auk* 105: 47–52.
- Green, R. E., S. J. Cornell, J. Scharlemann & A. Balmford. 2005. Farming and the fate of wild nature. *Science* 207: 550–555.
- Hawkins, B. A. & J. A. F. Diniz-Filho. 2006. Beyond Rapoport's rule: Evaluating range size patterns of New World birds in a two-dimensional framework. *Global Ecol. Biogeogr.* 15: 461–469.
- , ———, C. A. Jaramillo & S. A. Soeller. 2006. Post-Eocene climate change, niche conservatism, and the latitudinal diversity gradient of New World birds. *J. Biogeogr.* 33: 770–780.
- Hijmans, R. J. & D. M. Spooner. 2001. Geographic distribution of wild potato species. *Amer. J. Bot.* 88: 2101–2112.
- Ibisch, P. L., C. Nowicki, N. Araujo, R. Müller & S. Reichle. 2005. Bolivia: Targeting ecological processes and functionality, not the "living dead". Pp. 83–84 in N. Dudley & J. Parish (editors), *Closing the Gap: Creating Ecologically Representative Protected Area Systems*. CBD Secretariat, Montreal.
- Irestedt, M., J. Fjeldså, U. S. Johansson & P. G. P. Ericson. 2002. Systematic relationships and biogeography of the tracheophone suboscines (Aves: Passeriformes). *Molec. Phylog. Evol.* 23: 499–512.
- , ———, J. A. A. Nylander & P. G. P. Ericson. 2004. Phylogenetic relationships of typical antbirds (Thamnophilidae) and test of incongruence based on Bayes factors. *B. M. C. Evol. Biol.* 4, 23: 1–16.
- , ——— & P. G. P. Ericson. 2006. Evolution of the ovenbird-woodcreeper assemblage (Aves: Furnariidae)—Major shifts in nest architecture and adaptive radiation. *J. Avian Biol.* 37: 261–272.
- Jansson, R. & M. Dynesius. 2002. The fate of clades in a world of recurrent climatic change: Milankovitch oscillations and evolution. *Annual Rev. Ecol. Syst.* 33: 741–777.
- Jetz, W., C. Rahbek & R. K. Colwell. 2004. The coincidence of rarity and richness and the potential signature of history in centers of endemism. *Ecol. Lett.* 7: 1180–1191.
- Johansson, U. S., P. Alström, U. Olsson, P. G. P. Ericson, P. Sundberg & T. D. Price. 2007. Build-up of the Himalayan avifauna through immigration: A biogeographical analysis of the *Phylloscopus* and *Seicercus* warblers. *Evolution* 61: 324–333.
- Jønsson, K. A. & J. Fjeldså. 2006. A phylogenetic supertree of oscine passerine birds (Aves: Passeri). *Zool. Scripta* 35: 149–186.
- Jørgensen, P. M. & S. León-Yáñez (editors). 1999. *Catalogue of the Vascular Plants of Ecuador*. Monogr. Syst. Bot. Missouri Bot. Gard. 75.
- , C. Ulloa, R. Valencia & J. E. Madsen. 1995. A floristic analysis of the high Andes of Ecuador. Pp. 221–237 in S. P. Churchill, H. Balslev, E. Forero & J. L. Luteyn (editors), *Biodiversity and Conservation of the Neotropical Montane Forests*. New York Botanical Garden, Bronx.
- Joseph, L., T. Wilke, E. Bermingham, D. Alpers & R. Ricklefs. 2001. Towards a phylogenetic framework for the evolution of shakes, rattles, and rolls in *Myiarchus* tyrant-flycatchers (Aves: Passeriformes: Tyrannidae). *Molec. Phylog. Evol.* 31: 139–152.
- Kessler, M. 1999. Plant species richness and endemism during natural landslide succession in a perhumid montane forest in the Bolivian Andes. *Ecotropica* 5: 123–136.
- & S. K. Herzog. 1998. Conservation status in Bolivia of timberline habitats, elfin forest and their birds. *Cotinga* 10: 50–54.

- , ———, J. Fjeldså & K. Bach. 2001. Species richness and endemism of plant and bird communities along two gradients of elevation, humidity, and land use in the Bolivian Andes. *Diversity Distributions* 7: 61–77.
- Kinzig, A. P., S. W. Pacala & D. Tilman. 2001. *The Functional Consequences of Biodiversity*. Princeton University Press, Princeton.
- Krabbe, N. & T. S. Schulenberg. 1997. Species limits and natural history of *Scytalopus tapaculos* (Rhinocryptidae), with descriptions of the Ecuadorian taxa, including three new species. *Ornithol. Monogr.* 48: 47–88.
- Lovette, I. J. 2004. Molecular phylogeny and plumage signal evolution in a trans Andean and circum Amazonian avian species complex. *Molec. Phylogen. Evol.* 32: 512–523.
- Luck, G. W. 2007. The relationships between net primary productivity, human population density and species conservation. *J. Biogeogr.* 34: 201–212.
- Moore, J. L., A. Balmford, T. Brooks, N. D. Burgess, L. A. Hansen, C. Rahbek & P. H. Williams. 2003. Performance of sub-Saharan vertebrates as indicator groups for identifying priority areas for conservation. *Conserv. Biol.* 17: 207–218.
- Myers, N. 1989. Threatened biotas: “Hotspots” in tropical forests. *Environmentalist* 8: 1–20.
- . 1990. The biodiversity challenge: Expanded hotspots analysis. *Environmentalist* 10: 243–256.
- Ohlson, J., J. Fjeldså & P. G. P. Ericson. 2008. Tyrant flycatchers coming out in the open: Ecological radiation in Tyrannidae (Aves, Passeriformes). *Zool. Scripta*. 37: 315–335.
- Orme, C. D. L., R. G. Davies, M. Burgess, F. Eigenbrod, N. Pickup, V. A. Olson, A. J. Webster, T.-S. Ding, P. C. Rasmussen, R. S. Ridgely, A. J. Stattersfield, P. M. Bennett, T. M. Blackburn, K. J. Gaston & I. P. F. Owens. 2005. Global hotspots of species richness are not congruent with endemism or threat. *Nature* 436: 1016–1019.
- Ortiz, P. D. 1975. *Las Montañas del Apurímac, Mantaro y Ene*, Tomo I. Imprenta Editorial “San Antonio,” Lima.
- Rahbek, C. 1995. The elevational gradient of species richness: A uniform pattern? *Ecography* 18: 200–205.
- & G. R. Graves. 2001. Multiscale assessment of patterns of avian species richness. *Proc. Natl. Acad. Sci. U.S.A.* 98: 4534–4539.
- , N. J. Gotelli, R. K. Colwell, G. L. Entsminger, T. F. L. V. B. Rangel & G. R. Graves. 2006. Predicting continental-scale patterns of bird species richness with spatially explicit models. *Proc. Roy. Soc. London, Ser. B, Biol. Sci.* 274: 165–174.
- Remsen, J. V. 2003. Family Furnariidae (ovenbirds). Pp. 162–357 in J. del Hoyo, A. Elliot & D. Christie (editors), *Handbook of the Birds of the World*, Vol. 8. BirdLife International, Cambridge, United Kingdom, and Lynx, Barcelona.
- Ricklefs, R. E. 2003. Global diversification rates of passerine birds. *Proc. Roy. Soc. London, Ser. B, Biol. Sci.* 270: 2285–2291.
- Sibley, C. G. & J. E. Ahlquist. 1990. *Phylogeny and Classification of Birds: A Study of Molecular Evolution*. Yale University Press, New Haven.
- Stattersfield, A. J., M. J. Crosby, A. J. Long & D. C. Wege. 1998. *Endemic Bird Areas of the World: Priorities for Biodiversity Conservation*. BirdLife International, Cambridge, United Kingdom.
- Storch, D., X. Davies, R. G. Dajčec, C. D. L. Orme, V. Olson, G. H. Thomas, T.-S. Ding, P. C. Rasmussen, R. S. Ridgely, P. M. Bennett, T. M. Blackburn, I. P. F. Owens & K. J. Gaston. 2006. Energy, range dynamics and global species richness patterns: Reconciling mid-domain effects and environmental determinants of avian diversity. *Ecol. Lett.* 9: 1308–1320.
- Stotz, D. F. 1998. Endemism and species turnover with elevation in montane avifaunas in the neotropics: Implications for conservation. Pp. 161–180 in G. M. Mace, A. Balmford & J. R. Ginsberg (editors), *Conservation in a Changing World*. Cambridge University Press, Cambridge, United Kingdom.
- Tello, J. G. & J. M. Bates. 2007. Molecular phylogenetics of the tody-tyrant and flatbill assemblage of tyrant flycatchers (Aves: Tyrannidae). *Auk* 124: 134–154.
- van Rensburg, B. J., B. F. N. Erasmus, A. S. van Jaarsveld, K. J. Gaston & S. L. Chown. 2004. Conservation during times of change: Correlations between birds, climate and people in South Africa. *S. Afr. J. Sci.* 100: 266–272.
- Vuilleumier, F. 1980. Speciation in birds of the High Andes. *Acta XVII Congr. Int. Ornithol. Berlin* 2: 1256–1261.
- Weir, J. T. 2006. Divergent timing and patterns of species accumulation in lowland and highland Neotropical birds. *Evolution* 60: 842–855.
- Wilf, P., N. R. Cúneo, K. R. Johnson, J. F. Hicks, S. L. Wing & J. D. Obradovich. 2003. High plant diversity in Eocene South America: Evidence from Patagonia. *Science* 300: 122–125.
- Williams, P. H. 1998. Key sites for conservation: Area-selection methods for biodiversity. Pp. 211–249 in G. M. Mace, A. Balmford & J. Ginsberg (editors), *Conservation in a Changing World*. Cambridge University Press, Cambridge, United Kingdom.
- Young, K. R. & B. León. 1999. *Peru’s Humid Eastern Montane Forests: An Overview of Their Physical Settings, Biological Diversity, Human Use and Settlement, and Conservation Needs*. DIVA Technical Report No. 5, National Environmental Research Institute, Rønde, Denmark.

IMPLICATIONS OF GENETIC DIFFERENTIATION IN NEOTROPICAL MONTANE FOREST BIRDS¹

Jason T. Weir²

ABSTRACT

The complex geography of the Neotropical montane system is a natural laboratory for population divergence. Understanding which geographic barriers (lowland barriers, arid river valleys, and montane barriers above the tree line separate these regions of endemism) are instrumental in promoting and maintaining population divergence is an important step in preserving genetic diversity and endemism within the region. Here, I analyze patterns of genetic differentiation between 16 predefined regions of endemism for 43 co-distributed zoogeographic species complexes of Neotropical montane forest birds. The analysis shows that lowland barriers generate the highest levels of genetic differentiation, while barriers above the tree line in the Andes show the least. Within the Andes, arid river valleys promote population divergence to varying degrees. The Río Marañón shows the greatest effect, but the Río Apurímac and Río Quinimari are also associated with extensive genetic differentiation, while genetic divergence across other river valleys is generally weak. Most barriers are associated with a wide span of divergence times, supporting a protracted history of dispersal postdating barrier formation. If the goal is to maintain genetic diversity, preservation of populations within each region of endemism would help to ensure the continued survival of evolutionarily distinct lineages within species. Considering the alarming rate of deforestation in Neotropical montane regions, preservation of suitable tracts of montane forest is needed within each region of endemism, with special emphasis placed on endemism regions separated by lowland barriers and by deep intermontane river valleys.

Key words: Andes, birds, endemism, Neotropical, phylogeography, river barriers.

The Neotropics possess the world's most species-diverse floras and faunas (Rosenzweig, 1995; Newton, 2003; Kreft & Jetz, 2007). In birds, ca. 3000 continental species occur (Newton, 2003), far more than in any other biogeographic realm. Almost half of Neotropical avian species occur in a complex chain of highland regions extending from Mexico to Argentina. The chief components of the Neotropical highland system are the Andes, extending the entire length of South America from Tierra del Fuego in the south to Venezuela in the north. A chain of isolated highland regions extends northward through Central America to Mexico, and additional isolated highland regions occur in northern South America (Fig. 1). This highland system is the largest and geographically most complex at tropical latitudes, and its ongoing uplift has promoted extensive diversification opportunities (Weir, 2006; Ribas et al., 2007).

Over the past 10 million years, extensive orogeny occurred throughout the Neotropics (Gregory-Wodzicki, 2000; Grafe et al., 2002; Audemard, 2003; Dhont et al., 2005). Diversification occurred in Neotropical highland birds throughout this period,

with little indication of a slowdown in diversification rates (Weir, 2006). However, Neotropical lowland faunas experienced a slowdown in diversification rates over the same time period (Weir, 2006). The contrast suggests that highland regions are key cradles of diversity in the Neotropical region and their preservation is of utmost importance.

Unlike lowland wet forest species, which generally occupy large geographic ranges, a high degree of local endemism has resulted because of the rugged terrain and geographic complexity of the Neotropical highland system (Gentry, 1992; Stattersfield et al., 1998; Valencia et al., 2000). Co-distributed species complexes often exhibit similar patterns of endemism. This finding has led several authors to define common patterns of endemism in Neotropical montane birds shared across a wide diversity of taxa (Cracraft, 1985; Stotz et al., 1996; Stattersfield et al., 1998). The boundaries of many highland regions of endemism coincide with known or suspected geographic barriers believed by most authors to reduce or prevent gene flow (Vuilleumier, 1969; O'Neill, 1992). These boundaries include intervening lowland regions

¹ A special thanks to Trevor Price, Peter Jørgensen, and two anonymous reviewers whose suggestions helped improve this manuscript. C. Cadena and J. Garcia-Moreno provided unpublished sequences for *Arremon* and *Ochthoeca*, respectively. Funding was provided by a National Sciences and Engineering Research Council postdoctoral fellowship.

² Department of Ecology and Evolution, University of Chicago, 1101 E. 57th Street Chicago, Illinois 60637, U.S.A. jtweir@uchicago.edu.

doi: 10.3417/2008011

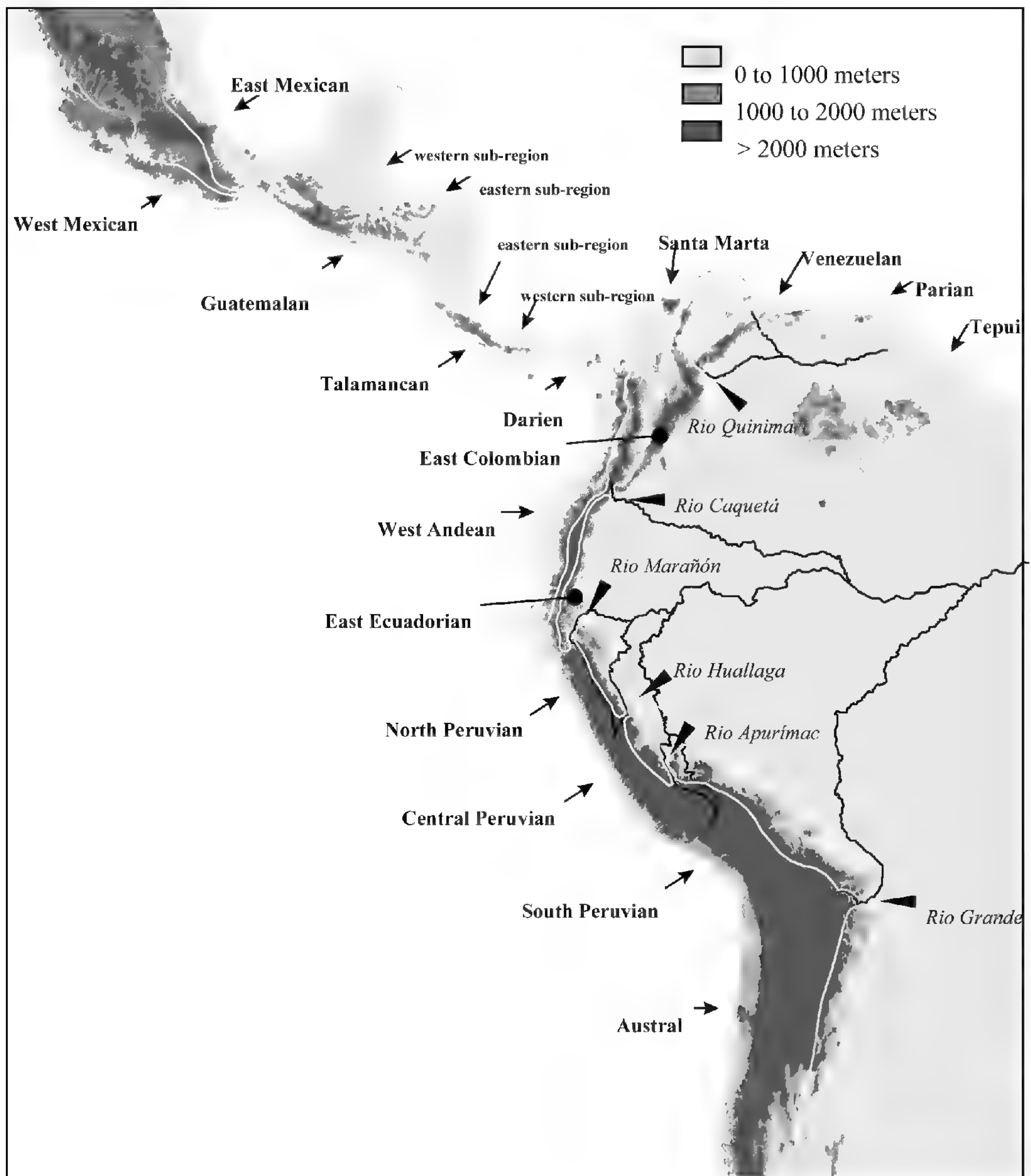

Figure 1. Geographic ranges of regions of endemism are analyzed. River valleys and lowland isthmuses separating Andean regions of endemism are illustrated. See text for other non-riverine barriers separating regions of endemism.

(which support a variety of habitat types that differ floristically from montane regions), arid inter-Andean river valleys, and high-elevation barriers above the tree line. However, the exact role of these barriers in promoting population divergence and speciation is debatable. Some authors suggested that montane forest diversification was primarily associated with ecologically stable regions that survived intact during recent glacial episodes, rather than as a consequence of geologic barriers (Fjeldså, 1995). While speciation

in a select group of highland taxa appears to have occurred on opposite sides of these barriers, giving rise to the observed patterns of endemism, many other species are distributed across barriers and occupy multiple regions of endemism. Thus, it remains unknown to what extent these barriers promote population divergence in general.

Here, I analyzed phylogenetic patterns in a set of 43 Neotropical humid montane forest species complexes in order to understand how proposed barriers

promote and maintain genetic differentiation between regions of endemism. I compared genetic differentiation in mitochondrial DNA between adjacent highland regions of endemism for both species-level taxa and intraspecific populations in order to assess the general usefulness of treating regions of endemism as distinct conservation regions.

MATERIALS AND METHODS

TAXON SAMPLING

I used zoogeographic species complexes (Mayr & Short, 1970; Fjeldså & Krabbe, 1990; Mayr & Diamond, 2001) to analyze phylogenetic patterns within Neotropical highland regions. Zoogeographic species, as used in this study, include monophyletic (at least in mitochondrial DNA phylogenies) clades composed of one or more allopatric or parapatric taxa, but do not contain taxa with sympatric distributions (other than highly local sympatry along contact zones). In a phylogenetic context, zoogeographic species represent the largest inclusive clades of taxa within genera that lack sympatric overlap. Because taxa within zoogeographic species lack sympatry, they retain the geographic signature of the diversification process and are ideal units to analyze the role of dispersal barriers in promoting diversification. In most cases, zoogeographic species include very closely related taxa that are considered to form superspecies complexes and are likely capable of at least limited interbreeding, should migration occur between them.

All zoogeographic species occupying Neotropical montane forest were included (Table 1), for which mitochondrial protein-coding DNA sequences representing two or more highland regions (Fig. 1) were available. The sample included both zoogeographic species composed of a single and multiple allopatric species and spanned a wide taxonomic diversity (Table 1). Sampling within zoogeographic species was not random geographically, with the greatest effort occurring in Bolivia, Peru, Ecuador, Panama, and Costa Rica. Samples from Colombia, Venezuela, and the tepuis were available for only a few zoogeographic species (Table 1).

ENDEMISM REGIONS

Areas of highland endemism have been defined for Neotropical birds by Cracraft (1985) for South America and in greater detail by Stattersfield et al. (1998) and Stotz et al. (1996) for the entire Neotropical region. The regions of endemism defined by the three studies correlate closely in most cases, although Stattersfield et al. (1998) split a number of Cracraft's regions more finely. I studied differentiation

across a modified classification of these regions for montane humid forest (Fig. 1). I did not include some regions for which sequence data were unavailable, and several regions of endemism were split more finely into subregions of endemism (see Fig. 1).

Montane humid forest (also referred to as montane evergreen forest) ranges ca. 1000–1500 m (locally lower, especially along the Pacific slope of the north Andes and in the Darién Highlands; Gentry, 1986) to the tree line, which at tropical latitudes generally varies from 3000–3500 m. Humid montane forest is characterized by a profusion of moss and other epiphytes, which liberally blanket branches and trunks of trees (Stotz et al., 1996). Humid montane forest is strongly bisected in the Neotropical region by a series of lowland barriers, arid river valleys, and highland barriers above the tree line. Adjacent regions of endemism are almost always separated by one of these barriers.

PHYLOGENETIC ANALYSIS

Mitochondrial protein-coding DNA sequences for Neotropical montane forest birds were obtained from previously published phylogenetic or phylogeographic studies or sequenced for this project (Tables 1, 2) using standard protocols (Weir et al., 2008). Model-corrected genetic distances were compared between adjacent highland regions. Parameters of the general time reversible (GTR)- Γ model of sequence evolution were estimated using maximum likelihood in PAUP 4.0b10 (Swofford, 2002) from a neighboring tree rooted with *Struthio* L. Parameters were estimated separately for each gene. Maximum likelihood parameter estimates were used to obtain GTR- Γ distances between sampled individuals.

Barriers may promote genetic differentiation between populations in several ways. Barrier formation may result in the vicariant fragmentation of widespread species into populations on either side of a barrier. If gene flow is prevented or greatly reduced, then the populations will begin to differentiate in mitochondrial DNA markers on opposite sides of the barrier. In such cases, mitochondrial sequence divergence can be transformed into time estimates of barrier formation using an appropriate molecular clock. For species that did not span a barrier when it formed, dispersal across a barrier might result in the formation of founder populations any time after barrier formation. Again, provided that gene flow is prevented or greatly reduced by the barrier, genetic differentiation will occur on either side of the barrier and sequence divergence can be converted into a time estimate of the founder event using a molecular clock. Caveats arise when leaky barriers allow limited amounts of gene flow, which may

prevent mitochondrial differentiation after vicariance or founder events. The degree of genetic differentiation, however, provides an approximate timescale for the cessation of gene flow and may postdate the initial vicariant or founder events.

Based on 84 avian calibrations supported by cross validation, an average molecular rate of close to 2% was strongly supported (Weir & Schluter, 2008) for model (GTR- Γ)-corrected distances of the mitochondrial cytochrome b gene. The 2% rate applies to divergence dates spanning the past 12 million years (Weir & Schluter, 2008) and is used throughout this study to convert model-corrected sequence divergence (using the same model that is used in the clock calibrations) into approximate time estimates of when populations began to differentiate in protein-coding mitochondrial DNA markers. DNA from cytochrome b was used in all but eight of the 44 zoogeographic species complexes analyzed here. The remaining eight used either ATPase 6 and 8 (*Henicorhina* P. L. Sclater & Salvin) or ND2 (*Hemispingus* Cabanis, *Ochthoeca* Cabanis, *Troglodytes* Vieillot), two protein-coding mitochondrial DNA genes that evolve at similar rates to cytochrome b (e.g., Lovette, 2004; Weir et al., 2008).

Sequence divergence actually measures coalescent times, the point at which haplotypes begin to diverge. Coalescent times and population splitting times will be equivalent if no standing variation occurred at the time of population splitting. If ancestral polymorphism in DNA haplotypes was present at population splitting, daughter populations will inherit a degree of genetic variation. If daughter populations randomly fix different alleles, then the date at which the fixed haplotypes coalesce will predate the time of population splitting. The discrepancy between coalescent and population splitting dates can be estimated by assuming that current and past levels of standing genetic variation within populations are the same. In Neotropical highland birds, protein-coding mitochondrial DNA haplotype divergence averages 0.4%, suggesting that coalescent times predate population splitting times by only 0.2 million years (Ma) (Weir, 2006). Given that the discrepancy is slight, uncorrected coalescent dates are reported here.

Two methods were used to construct consensus area cladograms of highland regions. The first used standard approaches for constructing supertrees (Baum, 1992; Bininda-Emonds, 2004). Supertrees are generally constructed from different gene phylogenies for a common set of taxa, although each phylogeny may not contain all taxa. Here, I used phylogenies of co-distributed zoogeographic species to generate a supertree for a common set of geographic regions (supertree area cladogram [SAC]). Input phylogenies in the SAC method may show discordant topologies just as they do

in the regular supertree method when using topologies from different genes. The SAC method finds the topology with the fewest steps required under parsimony criteria. This topology should be viewed as a compromise that finds the strongest overriding phylogenetic signal in the data set.

Maximum likelihood or Bayesian molecular phylogenies of montane forest taxa were obtained from published molecular phylogenies or were generated from unpublished data sets using standard methods (Weir, 2006). Trees were included for all zoogeographic species with samples from three or more highland regions. Next, I converted phylogenies manually to matrix representation (Bininda-Emonds & Bryant, 1998). A fully bifurcating tree with n tips is converted to a matrix with n rows and $n-1$ columns (polytomies can also be coded but result in $n-1-p$ columns, where p is the number of nodes collapsed into polytomies). Each row represents a geographic region and each column a node on the phylogeny. All descendent regions for a given node are coded as 1, and all outgroup regions to that node are coded as 0. Geographic regions not sampled are coded either as missing if the zoogeographic species occupies the region but was not sampled, or as 0 if the zoogeographic species is absent from the region in question.

The SAC method may perform poorly by giving equal weight to each column in the supermatrix irrespective of whether nodes in input phylogenies received strong support. One option is to weight each column (i.e., input node) in the supermatrix based on its nodal support. This option requires that the same nodal support metric be used consistently across input trees. In this analysis, most input topologies were derived from published maximum likelihood and Bayesian phylogenies, which use different measures of support, and no weighting was implemented.

Matrices for each zoogeographic species were concatenated, and parsimony analysis was performed on the combined matrix. Several types of parsimony analysis have traditionally been performed in supertree analysis. These analyses generally perform similarly (Bininda-Emonds & Sanderson, 2001; Bininda-Emonds, 2004). However, when adapting supertree methods to generate consensus area cladograms, reversible parsimony methods are preferable because they make no assumptions regarding extinction. I performed standard parsimony (standard matrix representation parsimony; Baum, 1992), which allows reversals and local extinction. A heuristic search of tree space was performed in PAUP 4.0b10 (Swofford, 2002) with stepwise addition, random sequence addition (25 replicates), tree bisection-reconnection swapping, and a maximum of 100 trees stored at any time. Strict consensus cladograms were constructed from all equally

Table 1. Geographic distributions of Neotropical montane forest zoogeographic species complexes included in this study. Regions of endemism occupied by a zoogeographic species but not sampled in this study are represented by 0; those that were sampled are represented by 1. Regions of endemism codes as used in Figure 4 are shown for Mexico and Middle America (C1 to C7), the Andes (A1 to A8), and isolated South American regions (S1 to S3).

Zoogeographic species complex	West Mexican (C1)	East Mexican (C2)	Guatemalan West (C3)	Guatemalan East (C4)	Talamanca West (C5)	Talamanca East (C6)	Darién (C7)	Tepui (S1)	Parí (S2)	Santa Marta (S3)	Venezuelan (A1)	East Colombian (A2)	East Ecuadorian (A3)	West Andean (A4)	North Peruvian (A5)	Central Peruvian (A6)	South Peruvian (A7)	Austral (A8)	Phylogenetic reference
Three or more regions sampled																			
<i>Arremon brunneinucha</i> Lafresnaye (chestnut-capped brush-finch)	1	1	1	1	1	1	1				1	1	1	1	1	1	1	1	Cadena et al., 2007
<i>A. torquatus</i> Lafresnaye & d'Orbigny (stripe-headed brush-finch)			1				1	0	1	1	1	1	1	1	1	1	1	1	Cadena et al., 2007
<i>Andigena</i> Gould complex ¹													0	1	0	1	1	1	Nahum et al., 2003; Moyle, 2004; Weckstein, 2005
<i>Cacicus chrysonotus</i> Lafresnaye & d'Orbigny (mountain cacique)													1	0	1	0	1	1	Price & Lanyon, 2004
<i>Campylorhynchus pusillus</i> P. L. Sclater (brown-billed scythebill)					1	0	1					0	1	1	0				This study
<i>Chlorospingus canigularis</i> Lafresnaye (ashy-throated bush-tanager)					1							0	1	1	0	0	0	0	Weir et al., 2008
<i>C. flavigularis</i> P. L. Sclater (yellow-throated bush-tanager)						1	0					0	0	1	0	0	1	1	Weir et al., 2008
<i>Chlorospingus Cabanis</i> complex ²	1	1	1	1	1	1	1				1	0	1	1	1	1	1	1	Weir et al., 2008
<i>Cinclus</i> Borkhausen complex ³	0	0	0	0	0	0	0			0	0	0	0	1	0	1	0	1	Voelker, 2002
<i>Cranioleuca</i> Reichenbach complex A ⁴					0	0	1	1	0	0	0	1	1	1	0	1	1	1	This study; Garcia-Moreno et al., 1999

Table 1. Continued.

Zoogeographic species complex	West Mexican (C1)	East Mexican (C2)	Guatemalan West (C3)	Guatemalan East (C4)	Talamanca West (C5)	Talamanca East (C6)	Darién (C7)	Tepui (S1)	Parían (S2)	Santa Marta (S3)	Venezuelan (A1)	East Colombian (A2)	East Ecuadorian (A3)	West Andean (A4)	North Peruvian (A5)	Central Peruvian (A6)	South Peruvian (A7)	Austral (A8)	Phylogenetic reference
<i>Diglossa</i> Wagler complex ⁵	1	0	0	0	1	1	0	0	0	0	0	0	0	0	1	0	0	0	Hackett, 1995
<i>Hemispingus</i> Cabanis complex A ⁶																			García-Moreno et al., 2001
<i>Hemispingus</i> complex B ⁷																			García-Moreno et al., 2001
<i>Henicorhina leucophrys</i> Tschudi (gray-breasted wood-wren)	0	0	0	0	1	0	0	0	0	0	0	0	1	1	0	1	0	0	Dingle et al., 2006
<i>Lampornis amethystinus</i> Swainson (amethyst-throated hummingbird)	1	1	1	1	1	1													García-Moreno et al., 2006
<i>Lampornis</i> Swainson complex ⁸																			García-Moreno et al., 2006
<i>Metallura tyrianthina</i> Loddiges (Tyrian metaltail)																			García-Moreno et al., 1999
<i>Myadestes</i> Swainson complex ⁹																			Miller et al., 2007
<i>M. occidentalis</i> Stejneger (brown-backed solitaire)	1	1	1	0	1	1	1	1	1	1	0	0	1	1	0	1	1	0	Miller et al., 2007
<i>Myioborus</i> S. F. Baird complex ¹⁰																			Perez-Eman, 2005
<i>M. miniatus</i> Swainson (slate-throated redstart)	1	0	1	0	1	0	1	0	0	0	0	0	1	1	0	1	1	0	Perez-Eman, 2005
<i>Myrmotherula schisticolor</i> Lawrence (slaty antwren)																			Weir, unpublished data
<i>Ochthoeca cinnamomeiventris</i> Lafresnaye (slaty-backed chat-tyrant)																			García-Moreno et al., 1998
<i>O. frontalis</i> Lafresnaye (crowned chat-tyrant)																			García-Moreno et al., 1998
<i>O. fumicolor</i> P. L. Sclater (brown-backed chat-tyrant)																			García-Moreno et al., 1998
<i>Ochthoeca</i> Cabanis complex ¹¹																			García-Moreno et al., 1998

Table 1. Continued.

Zoogeographic species complex	West Mexican (C1)	East Mexican (C2)	Guatemalan West (C3)	Guatemalan East (C4)	Talamanca West (C5)	Talamanca East (C6)	Darién (C7)	Tepui (S1)	Parian (S2)	Santa Marta (S3)	Venezuelan (A1)	East Colombian (A2)	East Ecuadorian (A3)	West Andean (A4)	North Peruvian (A5)	Central Peruvian (A6)	South Peruvian (A7)	Austral (A8)	Phylogenetic reference
<i>Pionus sordidus</i> Linnaeus (red-billed parrot)					1	1	1	1	1	1	1	1	0	1	1	0	0	0	Ribas et al., 2007
<i>Tangara</i> Brisson complex A ¹²					1	1	1			0	0	0	0	1	0	1	0	0	This study; Burns & Naoki, 2004
<i>T. florida</i> P. L. Sclater & Salvin (emerald tanager)					1	1	1			0	0	0	0	1	0				This study; Burns & Naoki, 2004
<i>T. guttata</i> Cabanis (speckled tanager)					0	1	1	1	0	0	0	0	0	0	0				This study; Burns & Naoki, 2004
<i>Thamnistes anabatinus</i> P. L. Sclater & Salvin (russet antshrike)			0	0	1	0	1			0	0	0	1	1	1	0	0	0	This study; Irestedt et al., 2004
<i>Troglodytes</i> Vieillot complex ¹³			1	0	1	0	0	1		0	0	0	0	0	0	1	0	0	Rice et al., 1999
<i>Xiphocolaptes promeropyrhynchus</i> Lesson (strong-billed woodcreeper)	0	1	0	1	0	0		0	0	0	0	0	1	0	0	0	0	0	Weir, unpublished; Aleixo, 2002; Irestedt et al., 2004
<i>Xiphorhynchus erythropygius</i> P. L. Sclater (spotted woodcreeper)	0	0	0	0	1	0	1							1					This study; Aleixo, 2002
<i>Haplospiza rustica</i> Tschudi (slaty finch)	0	0	0	0	1	1	1	1		0	0	0	0	1	0	0	0	0	This study
Two adjacent regions sampled																			
<i>Catharus aurantirostris</i> Hartlaub (orange-billed nightingale-thrush)	1	0	0	1	0	0			0	0	0	0	0	0					Outlaw et al., 2003; Winker & Pruett, 2006
<i>Chrysothlypis chrysomelas</i> P. L. Sclater & Salvin (black-and-yellow tanager)			0	1	0	1	1												This study; Burns, 1997
<i>Cranioleuca</i> complex B ¹⁴												0	1	1	0	0	0	0	García-Moreno et al., 1999

Table 1. Continued.

Zoogeographic species complex	West Mexican (C1)	East Mexican (C2)	Guatemalan West (C3)	Guatemalan East (C4)	Talamanca West (C5)	Talamanca East (C6)	Darién (C7)	Tepui (S1)	Parían (S2)	Santa Marta (S3)	Venezuelan (A1)	East Colombian (A2)	East Ecuadorian (A3)	West Andean (A4)	North Peruvian (A5)	Central Peruvian (A6)	South Peruvian (A7)	Austral (A8)	Phylogenetic reference
<i>Pseliophorus</i> Ridgway complex ¹⁵	1	1	1	1	1	1	1	1	1	1	1	1	1	1	1	1	1	1	This study; Klicka & Spellman, 2007
<i>Semnornis</i> Richmond complex ¹⁶	1	0	1	0	1	0	0	0	0	0	0	0	0	0	0	0	0	0	Barker & Lanyon, 2000
<i>Tangara</i> complex B ¹⁷	0	0	1	0	1	0	0	0	0	0	0	0	0	1	0	0	0	0	Burns & Naoki, 2004
<i>Turdus</i> Linnaeus complex ¹⁸	0	0	1	0	1	0	1	0	0	0	0	0	0	1	0	0	0	0	Voelker et al., 2007
¹ <i>Andigena laminirostris</i> Gould (plate-billed mountain-toucan), <i>A. hypotauca</i> Gould (gray-breasted mountain-toucan), <i>A. cucullata</i> Gould (hooded mountain-toucan). ² <i>Chlorospingus ophthalmicus</i> Du Bus de Gisignies (common bush-tanager), <i>C. semifuscus</i> P. L. Sclater & Salvin (dusky bush-tanager), <i>C. tacarcunae</i> Griscom (Tacarcuna bush-tanager), <i>C. inornatus</i> Nelson (Pire bush-tanager). ³ <i>Cinclus mexicanus</i> Swainson (American dipper), <i>C. leucocephalus</i> Tschudi (white-capped dipper), <i>C. schulzi</i> Cabanis (rufous-throated dipper). ⁴ <i>Cranioleuca marcapatae</i> Zimmer (Marcapata spintail), <i>C. albiceps</i> d'Orbigny & Lafresnaye (light-crowned spintail), <i>C. vulpina</i> Pelzeln (rusty-backed spintail, lowland species), <i>C. obsoleta</i> Reichenbach (olive spintail, lowland species), <i>C. henricae</i> Majer & Fjeldså (Bolivian spintail), <i>C. pyrrothopia</i> Vieillot (stripe-crowned spintail), <i>C. albicapilla</i> Cabanis (creamy-crested spintail), <i>C. demissa</i> Salvin & Godman (tepui spintail), <i>C. erythroptus</i> P. L. Sclater (red-faced spintail). ⁵ <i>Diglossa baritula</i> Wagler (cinnamon-bellied flowerpiercer), <i>D. plumbea</i> Cabanis (slaty flowerpiercer), <i>D. sittoides</i> d'Orbigny & Lafresnaye (rusty flowerpiercer). ⁶ <i>Hemispingus atropileus</i> Lafresnaye (black-capped Hemispingus), <i>H. calophrys</i> P. L. Sclater & Salvin (orange-browed Hemispingus). ⁷ <i>Hemispingus verticalis</i> Lafresnaye (black-headed Hemispingus), <i>H. rufosuperciliaris</i> Blake & Hocking (rufous-browed Hemispingus). ⁸ <i>Lampornis castaneiventris</i> Gould (white-throated mountain-gem), <i>L. viridipallens</i> Bourcier & Mulsant (green-throated mountain-gem), <i>L. sybillae</i> Salvin & Godman (green-breasted mountain-gem), <i>L. calolaemus</i> Salvin (purple-throated mountain-gem), <i>L. cinereicauda</i> Lawrence (gray-tailed mountain-gem). ⁹ <i>Myadestes ralloides</i> d'Orbigny (Andean solitaire), <i>M. coloratus</i> Nelson (varied solitaire), <i>M. melanops</i> Salvin (black-faced solitaire). ¹⁰ <i>Myioborus torquatus</i> S. F. Baird (collared redstart), <i>M. bruniceps</i> Lafresnaye & d'Orbigny (brown-capped redstart), <i>M. albifrons</i> P. L. Sclater & Salvin (white-fronted redstart), <i>M. melanoccephalus</i> Tschudi (spectacled redstart), <i>M. ornatus</i> Boissonneau (golden-fronted redstart), <i>M. flavivertex</i> Salvin (yellow-crowned redstart), <i>M. pariae</i> Phelps & Phelps (Paria redstart), <i>M. albifacies</i> Phelps & Phelps (white-faced redstart), <i>M. castaneocapillus</i> Cabanis (tepui redstart), <i>M. cardonai</i> Zimmer & Phelps (saffron-breasted redstart). ¹¹ <i>Ochthoeca pulchella</i> P. L. Sclater & Salvin (golden-browed chat-tyrant), <i>O. diadema</i> Hartlaub (yellow-bellied chat-tyrant). ¹² <i>Tangara dowii</i> Salvin (spangle-cheeked tanager), <i>T. fucosa</i> Nelson (green-naped tanager), <i>T. nigroviridis</i> Lafresnaye (beryl-spangled tanager). ¹³ <i>Troglodytes rufociliatus</i> Sharpe (rufous-browed wren), <i>T. ochraceus</i> Ridgway (ochraceous wren), <i>T. monticola</i> Bangs (Santa Marta wren), <i>T. solstitialis</i> P. L. Sclater (mountain wren), <i>T. rufulus</i> Cabanis (tepui wren). ¹⁴ <i>Cranioleuca curata</i> P. L. Sclater (ash-browed spintail), <i>C. antisianis</i> P. L. Sclater (line-cheeked spintail). ¹⁵ <i>Pseliophorus luteoviridis</i> Griscom (yellow-green finch), <i>P. tibialis</i> Lawrence (yellow-thighed finch). ¹⁶ <i>Semnornis ramphastinus</i> Jardine (toucan barbet), <i>S. frantzii</i> P. L. Sclater (prong-billed barbet). ¹⁷ <i>Tangara heinei</i> Cabanis (black-capped tanager), <i>T. argyrofenges</i> P. L. Sclater & Salvin (green-throated tanager). ¹⁸ <i>Turdus infuscatus</i> Lafresnaye (black thrush), <i>T. nigrescens</i> Cabanis (sooty thrush).																			

Table 2. Collecting localities and GenBank accession numbers of samples sequenced for this project.

Taxon	Museum (tissue number)	Locality	Accession number
<i>Campylorhamphus pusillus</i>	LSUMZ B33822	Peru, Cajamarca, Cordillera del Condor, Picorama	FJ222626
<i>C. pusillus</i>	LSUMZ B11879	Ecuador, Esmeraldas, El Placer	FJ222627
<i>C. pusillus</i>	LSUMZ B1411	Panama, Darién, Cerro Pire, 9 km NW of Cana	FJ222628
<i>C. pusillus</i>	STRI JTW094	Panama, Bocas del Toro, Chiriquí to Chiriquí Grande Rd. at continental divide	FJ222629
<i>Chlorospingus canigularis</i>	LSUMZ B34949	Ecuador, Napo	FJ222652
<i>C. canigularis</i>	LSUMZ B34918	Ecuador, Pichincha	FJ222653
<i>C. canigularis</i>	LSUMZ B35820	Costa Rica, Cartago	FJ222654
<i>C. flavigularis</i>	FMNH 430078	Peru, Cusco, Paucartambo	FJ222655
<i>C. flavigularis</i>	STRI JTW 018	Panama, Veraguas, Santa Fe	FJ222656
<i>C. flavigularis</i>	LSUMZ B11936	Ecuador, Esmeraldas, El Placer	FJ222657
<i>Chrysothlypis chrysomelas</i>	STRI JTW016	Panama, Veraguas, Santa Fe	FJ222631
<i>Cranioleuca erythropis</i>	LSUMZ B2144	Panama, Darién	FJ222630
<i>Haplospiza rustica</i>	STRI EC-HRU-514	Ecuador, Carchi	FJ222647
<i>H. rustica</i>	LSUMZ B16173	Costa Rica, San José, La Georgina	FJ222648
<i>H. rustica</i>	LSUMZ B7451	Venezuela, Amazonas, Cerro de la Neblina	FJ222649
<i>Myrmotherula schisticolor</i>	LSUMZ B16048	Costa Rica, Heredia, 4 km SE of Virgen del Socorro	FJ222632
<i>M. schisticolor</i>	LSUMZ B2124	Panama, Darién, 6 km NW of Cana	FJ222633
<i>M. schisticolor</i>	FMNH 429987	Peru, Cusco, Paucartambo	FJ222634
<i>M. schisticolor</i>	LSUMZ B11979	Ecuador, Esmeraldas, El Placer	FJ222635
<i>Pseliophorus luteoviridis</i>	STRI JTW 533	Panama, Chiriquí, Cerro Colorado	FJ222659
<i>Tangara florida</i>	STRI JTW 169	Panama, Bocas del Toro, Chiriquí to Chiriquí Grande Rd. at continental divide	FJ222636
<i>T. florida</i>	STRI PA-TAL-1014	Panama, Veraguas, Santa Fe	FJ222637
<i>T. guttata</i>	STRI JTW 013	Panama, Veraguas, Santa Fe	FJ222638
<i>T. guttata</i>	AMNH 8807	Venezuela, Amazonas, Tamacuari	FJ222639
<i>Thamnistes anabatinus</i>	LSUMZ B6152	Ecuador, Morona-Santiago, W slope Cordillera del Cutucu	FJ222640
<i>T. anabatinus</i>	LSUMZ B2154	Panama, Darién, 6 km NW of Cana	FJ222641
<i>T. anabatinus</i>	FMNH JTW179	Panama, Bocas del Toro, Chiriquí to Chiriquí Grande Rd. at continental divide	FJ222642
<i>Xiphocolaptes promeropirhynchus</i>	FMNH 394013	Mexico, Hidalgo, 5 km E of Tlanchinol	FJ222643
<i>X. promeropirhynchus</i>	UWBM 56169	Nicaragua, 10 km N of Matagalpa	FJ222644
<i>Xiphorhynchus erythropygius</i>	FMNH JTW596	Panama, El Copé, El Copé National Park	FJ222645
<i>X. erythropygius</i>	FMNH JTW669	Panama, Darién, Puerto Pina	FJ222646
<i>Pseliophorus tibialis</i>	LSUMZ B9941	Costa Rica, San José	FJ222659

AMNH, American Museum of Natural History; FMNH, Field Museum of Natural History; LSUMZ, Louisiana Museum of Natural History; STRI, Smithsonian Tropical Research Institute (collected by author); UWBM, University of Washington Burke Museum of Natural History and Culture.

most-parsimonious trees. A bootstrap analysis of nodal support with 1000 bootstrap replicates was performed on the entire matrix following Purvis (1995). However, because nodes for each tree in matrix form are stored as nonindependent pseudocharacters, the assumption of character independence is not met. Furthermore, zoogeographic species occupying many geographic regions will be represented in the matrix by a greater number of nodes and will thus contribute more to bootstrap analysis. Given the current lack of more robust statistics of nodal support for supertrees, I use bootstrap analysis to provide a rough measure of nodal support. Regions of the tree with poor support are interpreted as reflecting conflicting topologies in input trees.

I constructed a second class of area cladograms directly from the sequence data for each zoogeographic species. Following Weir and Schluter (2004), sequences for each highland region were concatenated across all zoogeographic species complexes (sequence concatenation area cladogram [SCAC]). This was done by combining a DNA sequence from a single individual for each zoogeographic species within a highland region into a composite sequence. When a zoogeographic species was absent from a particular highland region or if a sequence was not available for that region, a series of *n*'s of appropriate length was inserted to represent the missing sequence. This method allows both the relationships between geographic regions and the

average branch lengths connecting geographic regions to be estimated directly from the sequence data and in this sense is more robust than supertree methods. A difficulty arises in rooting the analysis without selecting any geographic region to be an outgroup. Maximum-likelihood methods that use a clock or relaxed clock assumption automatically root the analysis without the aid of a predefined outgroup.

A Bayesian cladogram was estimated in Bayesian Evolutionary Analysis Sampling Trees (BEAST) v1.4.3 (Drummond & Rambaut, 2007) using the log-normal relaxed clock model with a Yule-prior for branch lengths. The coefficient of variation in rates (σ ; standard deviation in rates across lineages divided by mean rate) was significantly greater than zero in this analysis but less than one (mean = 0.52, 95%; highest posterior density = 0.38–0.66), indicating significant but minor rate variation across lineages. The analysis was run for 10 million generations and a sample saved every 1000 generations. The first 2.5 million generations were deleted as the burn-in period, and a consensus phylogeny with mean branch lengths was generated in FigTree (Rambaut, 2007).

A caveat of the SCAC method is that sequences from older zoogeographic species complexes will be more divergent than younger zoogeographic complexes. As a result, sequences from older taxa will contain more phylogenetically informative characters and will contribute more to the phylogenetic signal. One possibility is to weight each character for a given zoogeographic complex by the inverse of the number of phylogenetically informative characters in that complex. Weighting each character would force each zoogeographic complex to contribute evenly to the phylogenetic signal. However, weighting characters will interfere with branch length estimation and is not implemented here.

The same zoogeographic species were included in the SAC and SCAC analyses except that *Cinclus Borkhausen* was not included in the SCAC analysis because DNA sequences from a published phylogenetic analysis of *Cinclus* (Voelker, 2002) were not deposited in GenBank.

RESULTS

GENETIC DISTANCE ANALYSIS

GTR- Γ distances between adjacent highland regions are shown in Figures 2 and 3. Genetic distances are plotted separately for specifically distinct taxa versus conspecific populations.

Isthmus of Tehuantepec. Genetic distances between Mexican and Guatemalan regions (Fig. 2A) were available for six zoogeographic species complexes, all

but one considered conspecific by current taxonomic treatment. Genetic divergence ranged 0.6%–10% (or 0.3–5 Ma using the standard 2% clock) across the intervening Isthmus of Tehuantepec, suggesting that this lowland barrier has promoted extensive population differentiation in a number of zoogeographic species. Interestingly, the least diverged complex was the only one considered to comprise distinct species. By contrast, populations of *Arremon brunneinucha* Lafresnaye and *Chlorospingus ophthalmicus* Du Bus de Gisignies separated for approximately 5 and 2.6 Ma, respectively, are currently considered conspecific (American Ornithologists' Union, 1998).

Lowland isthmuses in lower Central America. The Guatemalan region is isolated from the Talamancan region by extensive lowland barriers in Nicaragua. Genetic differentiation across this lowland gap ranged 1%–9% (Fig. 2B) and had a similar distribution of divergence dates to the Isthmus of Tehuantepec. The three taxa with the greatest genetic differentiation across this gap are recognized as specifically distinct. Genetic differentiation in conspecific taxa ranged 1%–4.5%, again demonstrating substantial population divergence within some species. Genetic differentiation across the lowland gaps that separate Talamancan, Darién, and the west Andes ranged 0.7%–11.6% for taxa considered specifically distinct in these regions and 4.9%–11.7% for taxa considered conspecific (Figs. 2C, 3A, B).

South American lowland barriers. The Santa Marta, Parian, and tepui regions are isolated from each other and the Andes by lowland barriers. The Santa Marta in northern Colombia possesses a large number of endemic species ($n = 18$) and subspecies ($n = 55$) (Strewe et al., 2006), few of which have sequence data in GenBank. In the samples available, genetic divergence between the Santa Marta and east Colombian Andes ranged 2.6%–9.4% for conspecific taxa and 5.8%–11.3% for specifically distinct taxa (Fig. 3C). The Parian region represents an isolated highland region in the Parian Peninsula of eastern Venezuela. It is isolated by expansive lowland barriers from the closest highland region, the Venezuelan Andes. Across this gap, genetic distances for four zoogeographic species complexes ranged 0.4%–6.5% (Fig. 3D). Only one of these is considered specifically distinct (*Myioborus* S. F. Baird; 6.2%). The tepuis, a series of ancient highland regions of the Guayana Shield, are isolated from the Andes and the Parian region by the extensive Amazon and Orinoco basins. Many Andean zoogeographic species complexes do not

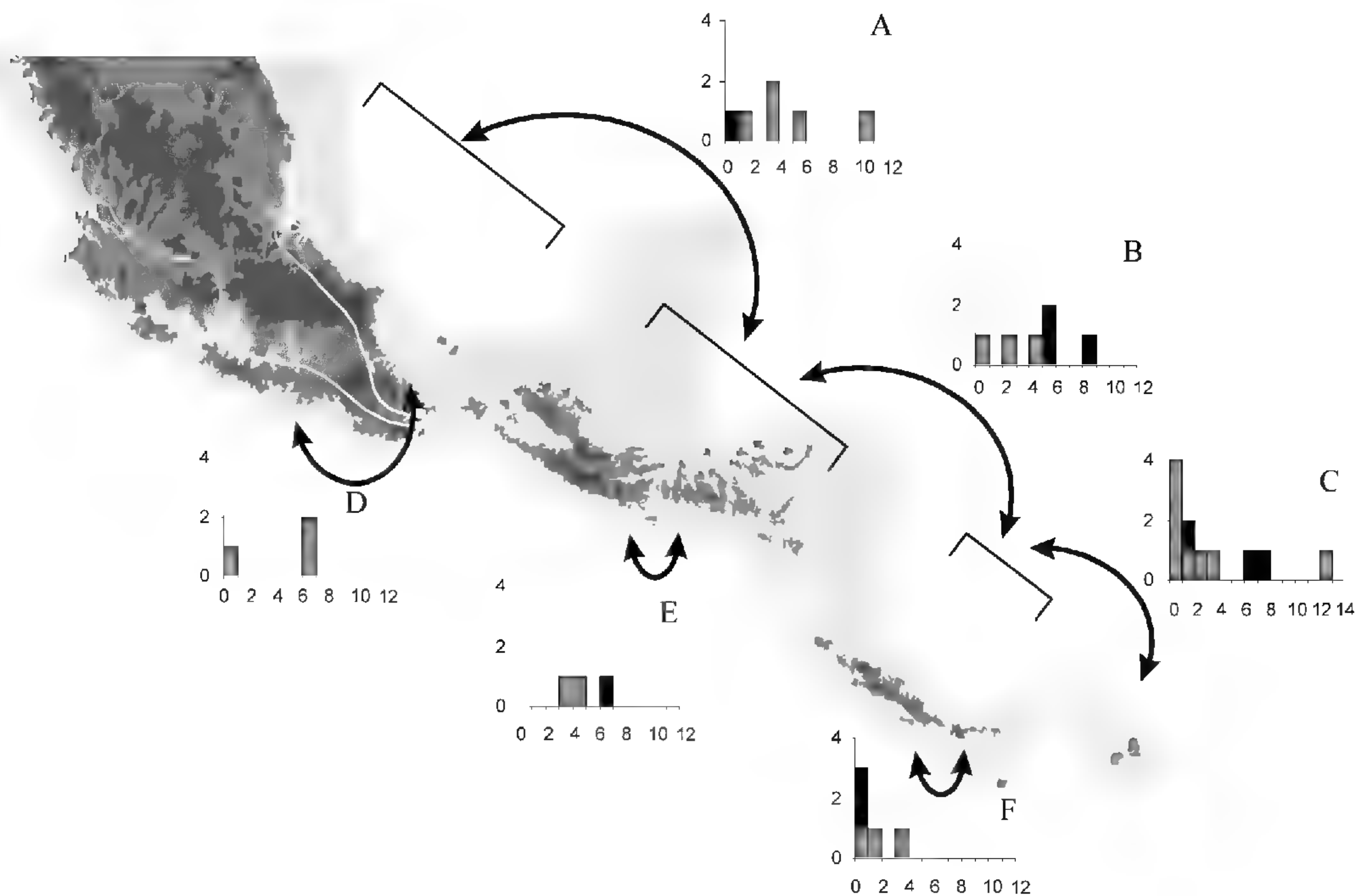

Figure 2. Histograms of genetic distances (x-axis — GTR- Γ corrected distances) between Mexican and Middle American regions of endemism derived from protein-coding mitochondrial DNA sequences. Distances between species-level taxa are shown in black and between conspecific populations in gray. The y-axis is the number of zoogeographic complexes with a given level of genetic differentiation. Comparisons of genetic differentiation between regions of endemism are as follows: (A) east Mexican and west Mexican versus Guatemalan, (B) Guatemalan versus Talamancan, (C) Talamancan versus Darién, (D) west Mexican versus east Mexican, (E) western versus eastern subregions within the Guatemalan region, and (F) western versus eastern subregions within the Talamancan region.

reach the tepuis. Of those that do, a large proportion of taxa represent endemic species or subspecies. Unfortunately, DNA sequences were available for only one zoogeographic complex (*Myioborus*), which is differentiated by 4%–5% from its relatives in the Parian (Fig. 3E), Venezuelan, and east Colombian regions. This complex is specifically distinct in each of these regions, and within the tepuis multiple species are described, suggesting that the tepuis may contain subregions of multiple endemism. Additional data are necessary to determine the magnitude of genetic differentiation of tepui populations from other highland regions of endemism.

Divergence across intermontane river valleys. A series of deep river valleys bisect montane forest patches along the eastern slope of the Andes and form barriers between adjacent regions of endemism. Each river valley promoted genetic differentiation, but to different extents. The Río Quinimari and its tributaries, which carved out the deep and arid Tachira Depression, separate the east Colombian and Venezuelan regions (Fig. 1). Genetic differentiation across this depression

in four zoogeographic species ranged 0%–6.2% (Fig. 3F), suggesting that this barrier has effectively promoted divergence in at least some species complexes. The Eastern Cordillera of the Colombian Andes and the Mérida Andes of Venezuela were uplifted rapidly, primarily between 5 and 3 Ma (Gregory-Wodzicki, 2000; Audemard, 2003; Dhont et al., 2005). The oldest divergence suggests that population divergence between the east Colombian and adjacent regions of endemism began around the time of when uplift was completed 3 Ma.

Either the Río Caquetá or a series of low-elevation montane passes may form the barrier between the east Colombian and east Ecuadorian regions. However, only limited genetic differentiation occurred in the two zoogeographic species complexes that span these potential barriers (Fig. 3G). One of these complexes has endemic species on either side of these barriers, yet showed only low levels of divergence. Additional sampling from the east Colombian region is necessary, but the two complexes available suggest that genetic differentiation is not great between these regions.

The North Peruvian Low and Río Marañón represent a barrier that fully bisects the Eastern

Cordillera of the Andes. This region is believed to form one of the most important barriers for Andean birds and other groups (Vuilleumier, 1969, 1980), because a number of sister species occur north and south of this region. Genetic differentiation across this barrier ranged as high as 6.1% (11% when the north and central Peruvian regions are analyzed together) in seven zoogeographic species, confirming its importance in promoting population divergence (Fig. 3I, J).

In contrast to the Río Marañón, five of the six species that span the Río Huallaga in Peru showed only limited genetic differentiation (Fig. 3K). However, *Chlorospingus ophthalmicus* showed 6% divergence across this river barrier, even though it showed no differentiation across the Río Marañón (Weir et al., 2008). Although Cracraft (1985) stated the importance of the Río Huallaga valley in delimiting the ranges of a small number of Peruvian endemics, he did not officially recognize the separation of the north and central Peruvian regions. The available evidence suggests that these regions were important in promoting population divergence in relatively few species. Further sampling is necessary.

Genetic differentiation across the Río Apurímac, which separates the central and south Peruvian regions, ranged 0.2%–14.3% (Fig. 3L). Like the Río Marañón, this river barrier has played a key role in promoting and maintaining population divergence and speciation in the Andes. Still, a substantial number of zoogeographic species showed limited or no divergence across this barrier, implying recent range expansions or ongoing gene flow across this valley.

Finally, the Río Grande and its tributaries have carved out an arid valley in Bolivia, isolating montane forest in the south Peruvian and Austral regions. Only three zoogeographic complexes spanned this barrier, and they showed moderate to large genetic differentiation ranging 1.3%–6% (Fig. 3M).

Divergence across nonforested montane barriers. Montane forest is distributed along both the eastern and western slopes of the Andes of Colombia and Ecuador south to the North Peruvian Low. High-elevation barriers above the tree line bisect montane forest along each slope. Genetic differentiation between the eastern and western slopes (Fig. 3H) ranged 0%–5.3% with nine of 12 taxa differentiated by less than 1%. The lack of strong genetic differentiation in most complexes suggests that at least prior to the mid and late Pleistocene glacial cycles, the high Andes did not form a strong barrier to dispersal. The severe glacial episodes of the mid and late Pleistocene directly glaciated high elevations of the Andes, lowering montane forest zones (Bennett, 1990; Hooghiemstra et al., 1993; Van't Veer & Hooghiemstra, 2000; Hooghiemstra & van der Hammen, 2004).

North of the Isthmus of Tehuantepec in Mexico, humid montane forest is distributed along the Sierra Madre Oriental in the east and the Sierra Madre Occidental and Sierra Madre Sur in the west (Fig. 1). These forests are separated by an arid high-elevation plateau. Population divergence between the west and east Mexican regions was available for only three zoogeographic species complexes, each considered conspecific by current taxonomic treatment. Genetic divergence between these regions was low for *Lampornis amethystinus* Swainson (0.6%), but was between 6% and 7% for *Arremon torquatus* Lafresnaye & d'Orbigny and *Chlorospingus ophthalmicus* (Fig. 2D), suggesting that populations of the latter two species have been separated for more than 3 million years.

Other barriers. I compared genetic differentiation between eastern and western subregions within both the Talamancan and Guatemalan regions. Three zoogeographic species complexes (*Pseliophorus* Ridgway, *Lampornis* Swainson, *Selasphorus* Swainson) have endemic species in each of the Talamancan subregions, two of which are included here (*Pseliophorus* and *Lampornis*). Populations in five zoogeographic species complexes exhibited minor to moderate genetic differentiation between the eastern and western subregions of the Talamanca (0.3%–3.8%; Fig. 2F). Two complexes contain endemic species, but in each case, these endemic species are separated by divergence values less than 1%. In addition, in *Lampornis*, samples from multiple individuals demonstrate that populations are not reciprocally monophyletic (García-Moreno et al., 1999).

Three zoogeographic species complexes spanned the two Guatemalan subregions, including one with endemic species in each subregion (*Lampornis*). In contrast to the Talamancan subregions, genetic distances between the Guatemalan subregions were high, ranging 3.7%–6% and suggesting divergence dates of 1.6–3 Ma (Fig. 2E).

AREA CLADOGRAM ANALYSIS

Input topologies of zoogeographic species complexes used in the SAC analysis are shown in Figure 4.

Supertree area cladograms. The supermatrix obtained from phylogenies for 35 zoogeographic species had 124 columns. Standard matrix representation parsimony resulted in a single most-parsimonious tree, requiring 196 steps (Figs. 5A, 6A).

Sequence concatenation area cladograms. The topology uncovered in the relaxed-clock Bayesian phylogeny (SCAC) varied in important ways from the SAC topology

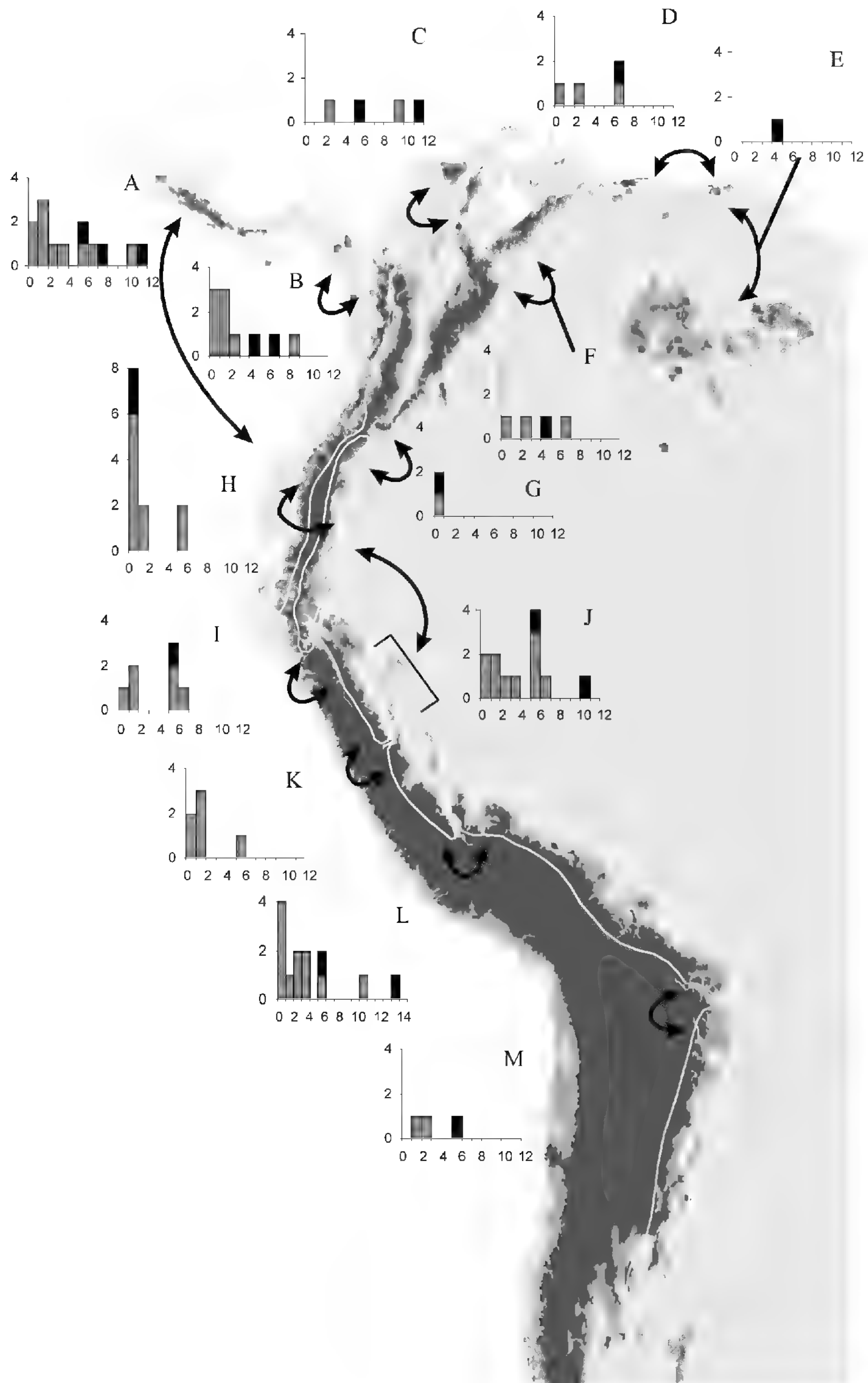

Figure 3. Histograms of genetic distances (x-axis — GTR- Γ corrected distances) between South American regions of endemism derived from protein-coding mitochondrial DNA sequences. Distances between species-level taxa are shown in black and between conspecific populations in gray. The y-axis is the number of zoogeographic complexes with a given level of genetic differentiation. Comparisons of genetic differentiation between regions of endemism are as follows: (A) Talamancan versus west Andean, (B) Darién versus west Andean, (C) Santa Marta versus east Colombian, (D) Venezuelan versus Parian, (E) Venezuelan versus Parian, (F) Venezuelan versus Parian, (G) Venezuelan versus Parian, (H) Darién versus west Andean, (I) Darién versus west Andean, (J) Darién versus west Andean, (K) Darién versus west Andean, (L) Darién versus west Andean, (M) Darién versus west Andean.

(Figs. 5, 6). The most striking difference was the grouping of the Talamanca and Darién regions with the Guatemalan and Mexican regions to produce monophyletic South American, Middle American, and Mexican clades, although posterior probability was low for these groupings. In the SAC topology, Talamanca and Darién were nested within the South American radiation.

Topology in those parts of the SCAC and SAC trees with nodal support greater than 0.9 posterior probability (SCAC) and 70% bootstrap support (SAC) generally agreed (Fig. 6). The main differences were the retention of a monophyletic Andean clade in the SCAC analysis but not in the SAC analysis.

Poor support for many nodes in both the SCAC and SAC analyses highlights the general discordance in input phylogenies (Fig. 4) between many regions of endemism. Because of this conflict, it is not straightforward how to interpret branch-length information in the SCAC analysis, even for those parts of the cladogram that have high nodal support.

DISCUSSION

THE ROLE OF LOWLAND BARRIERS

Populations within zoogeographic species complexes of Neotropical montane forest birds exhibited a wide range of genetic divergence between geographically adjacent regions of endemism (range, 0%–14%; Figs. 2, 3, 7, 8). Populations of zoogeographic species spanning lowland barriers (Fig. 7) exhibited the greatest genetic divergence (median = 3.4%), while populations spanning river valley barriers (median = 2.0%) and highland barriers (median = 0.6%) were less diverged; differences were significant only between the lowland and highland barriers (Mann-Whitney *U* test, $W = 451$; $P = 0.0139$). These differences are not surprising given that lowland barriers are generally wider geographically than other barrier types.

The lowland Isthmus of Panama distributed between the Talamanca and Darién highlands was inundated until 3–4 Ma when the final formation stage of the Central American land bridge was completed (Coates et al., 1992; Coates & Obando, 1996). Land bridge completion initiated full faunal interchange between North and South America in birds (Weir, unpublished data), mammals (Simpson, 1980; Webb, 1985), and other groups (Stehli & Webb, 1985), an event known as the Great American Biotic Interchange. A burst of interchange between the Talamanca and Darién and

between the Talamanca and the west Andean regions at or shortly after the land bridge completion is evident for highland birds (6%–8% sequence divergence; Figs. 2C, 3A).

A more recent burst during the last 1 million years (0%–2% sequence divergence) coincides with the severe glaciations of the Andes (Bennett, 1990; Hooghiemstra et al., 1993; Hooghiemstra & van der Hammen, 2004), Talamanca (Lachniet & Seltzer, 2002), Guatemalan highlands (Anderson, 1969), and Mexican highlands (White & Valastro, 1984; Heine, 1988) when montane forest was repeatedly lowered by as much as 1000 m in elevation (Van't Veer & Hooghiemstra, 2000; Hooghiemstra & van der Hammen, 2004). This lowering allowed some montane forest elements to expand into intervening lowland regions and may have increased the probability of dispersal of montane species across the isthmus (Hooghiemstra & Cleff, 1995).

Montane interchange during the past 1 million years was also observed across other lowland barriers (Figs. 2, 3), but none of them exhibited a distinct interchange burst during this time as observed between the Talamanca, Darién, and west Andes. This finding may simply reflect the small sample sizes across other lowland barriers, and additional sampling may reveal that interchange at this time was more extensive than the current data suggest. Alternatively, the mid to late Pleistocene elevational lowering of montane forests may have provided the first opportunity for most Andean species to disperse into the recently formed Talamanca and Darién highland regions following the land bridge completion. Late Pleistocene dispersal into other highland regions may have been hindered by competition with the species-diverse faunas that already inhabited those regions.

THE ROLE OF ARID RIVER VALLEYS

The role of arid river valleys in promoting population differentiation is controversial. These barriers may directly promote differentiation by preventing or minimizing gene flow (Vuilleumier, 1969). Alternatively, Fjeldså and his coauthors (Fjeldså, 1995; Fjeldså & Lovett, 1997; Fjeldså et al., 1997, 1999) proposed that river valleys were not responsible for promoting diversification events despite the fact that they demarcate adjacent regions of endemism and the range limits of a large proportion

←

(E) Parian versus tepui, (F) east Colombian versus Venezuelan, (G) east Colombian versus east Ecuadorian, (H) east Ecuadorian versus west Ecuadorian, (I) east Ecuadorian versus north Peruvian, (J) east Ecuadorian versus north Peruvian and central Peruvian, (K) north versus central Peruvian, (L) central versus south Peruvian, and (M) south Peruvian versus Austral.

Arremon brunneinucha*Myioborus miniatus**Chlorospingus* complex*Arremon torquatus**Myioborus* complex*Myadestes* complex*Cranioleuca* complex*Pionus sordidus**Tangara* complex

Figure 4. Area cladograms of Neotropical montane zoogeographic species complexes based on Bayesian or maximum likelihood topologies. Regions of endemism are labeled following codes in Table 1.

of Andean birds. In their view, regions of endemism along the Andes are associated with areas of climatic and ecologic stability that persisted over long time spans and throughout the Pleistocene climatic cycles. These areas of stability are seen to promote parapatric or sympatric speciation, without the need for geographic barriers to gene flow. While the model may apply commonly to taxa with parapatric or sympatric speciation, it is unlikely to apply commonly in birds for which sympatric speciation is rare and allopatric speciation is the predominant mode of diversification (Coyne & Price, 2000; Phillimore et al., 2008). While ecologically stable areas may help maintain species diversity in birds, they are unlikely to have commonly

promoted speciation without the aid of intervening geologic barriers to gene flow.

Rather than forming opposing models, ecologically stable areas and arid river valleys may have worked in concert to promote population divergence between regions of endemism. During periods of intense glaciation, montane forests were lowered by 1000 m or more in altitude (Van't Veer & Hooghiemstra, 2000; Hooghiemstra & van der Hammen, 2004), potentially forming a continuous forest belt across river valleys, or at least increasing the possibility of dispersal across them. During interglacial periods, montane forest returned to high altitudes, becoming once again fragmented by intervening river valleys.

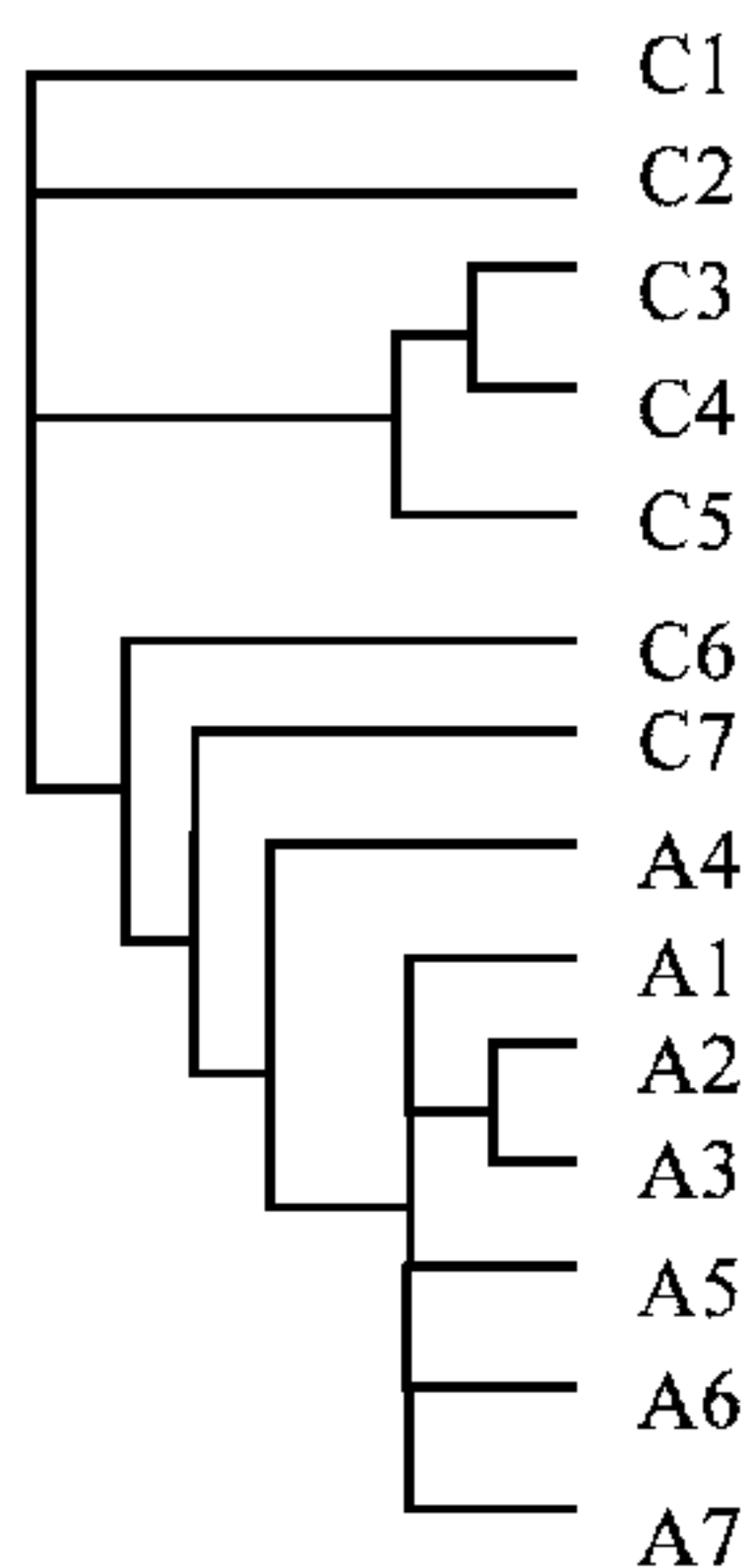
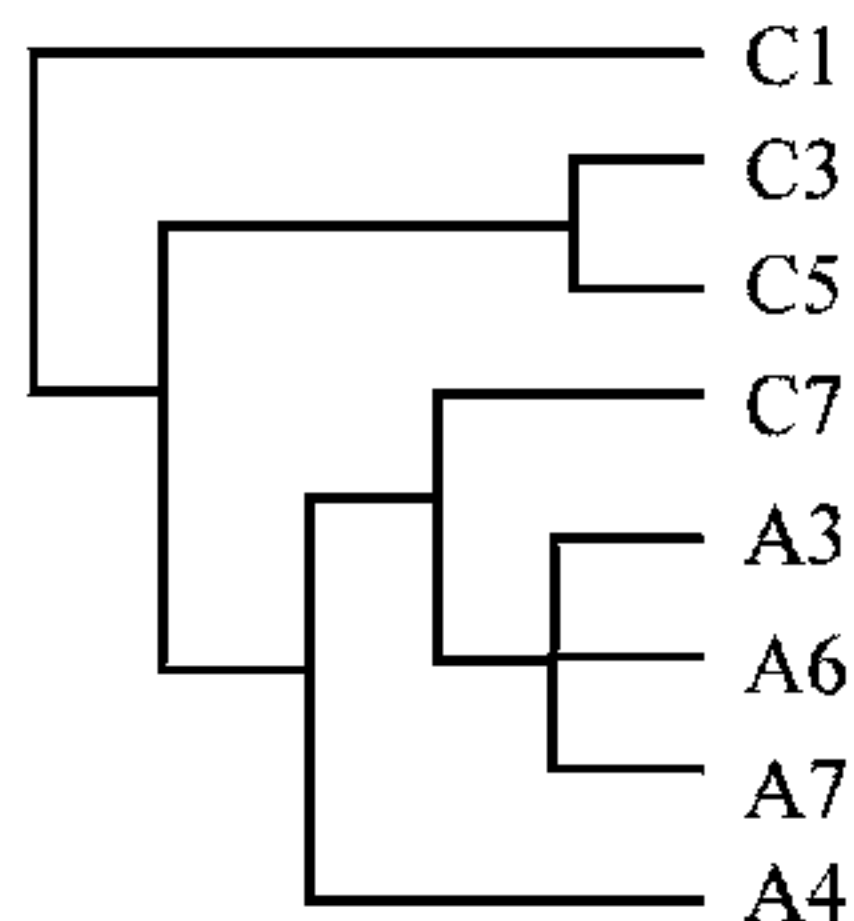
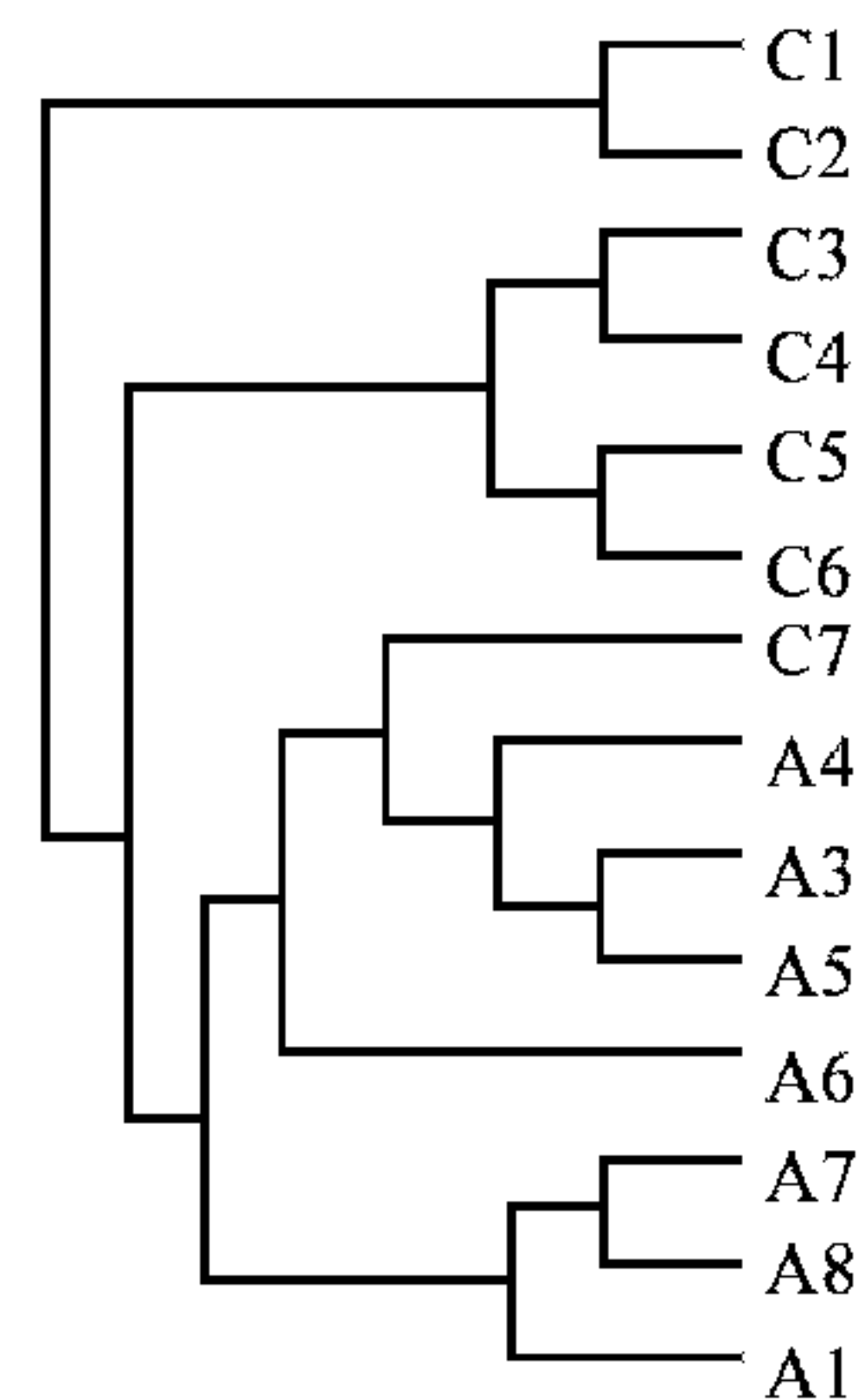
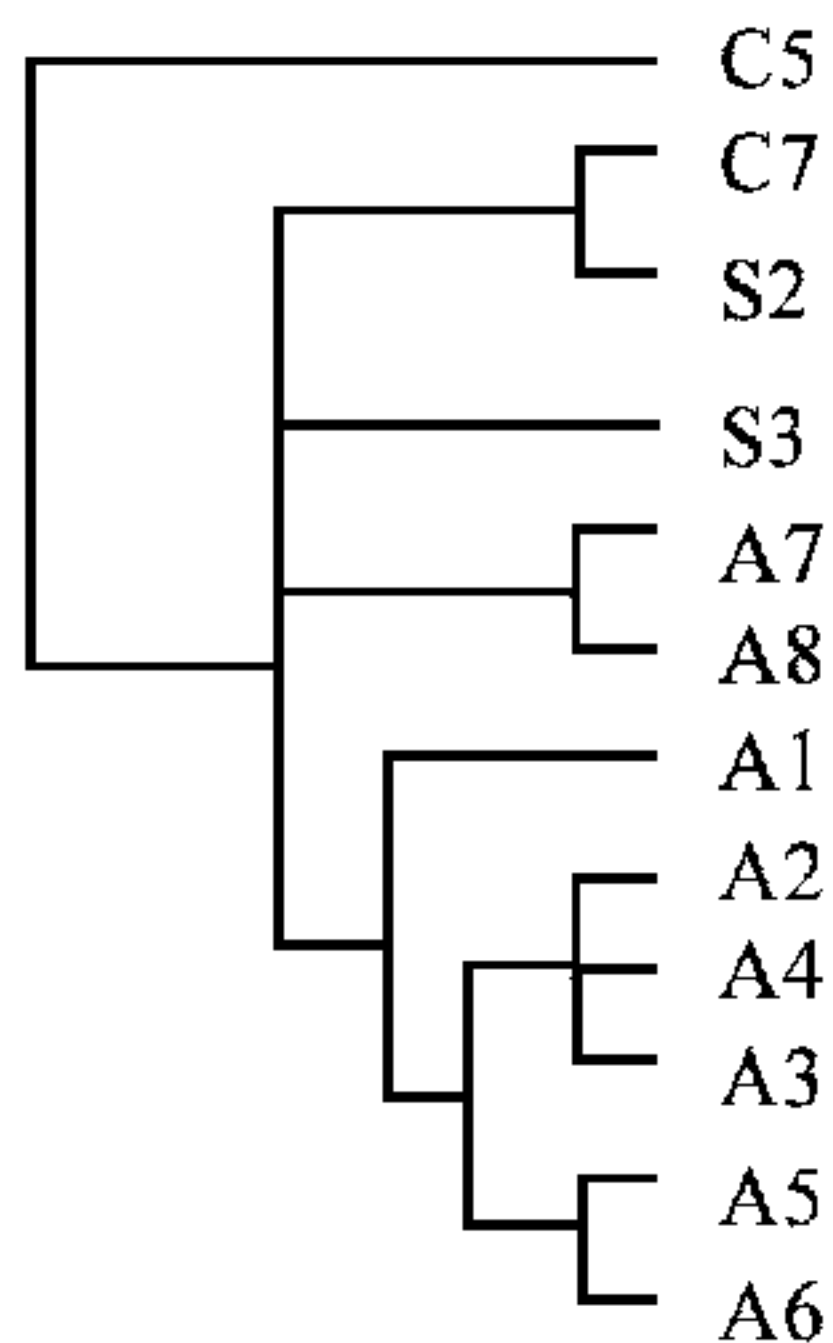
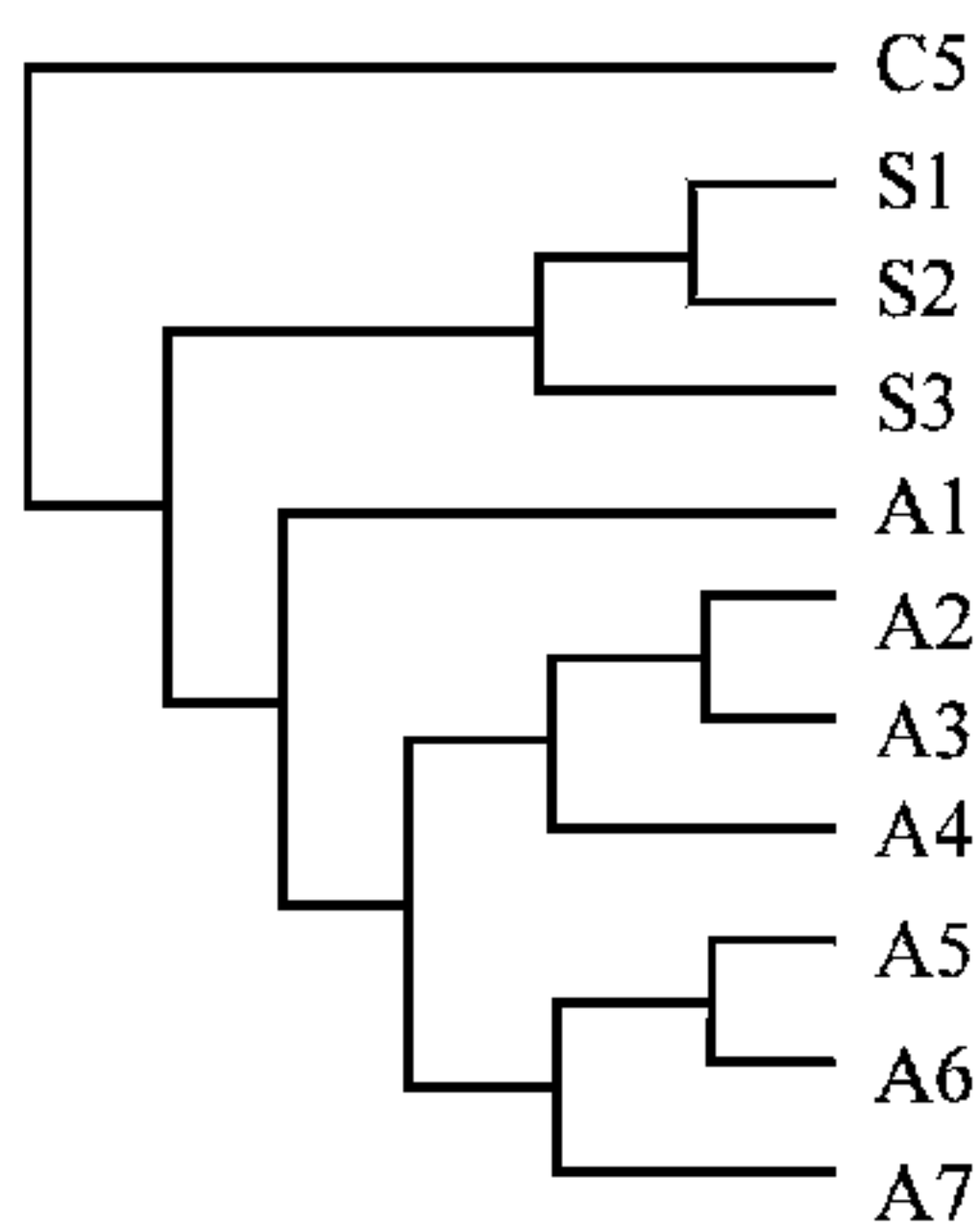
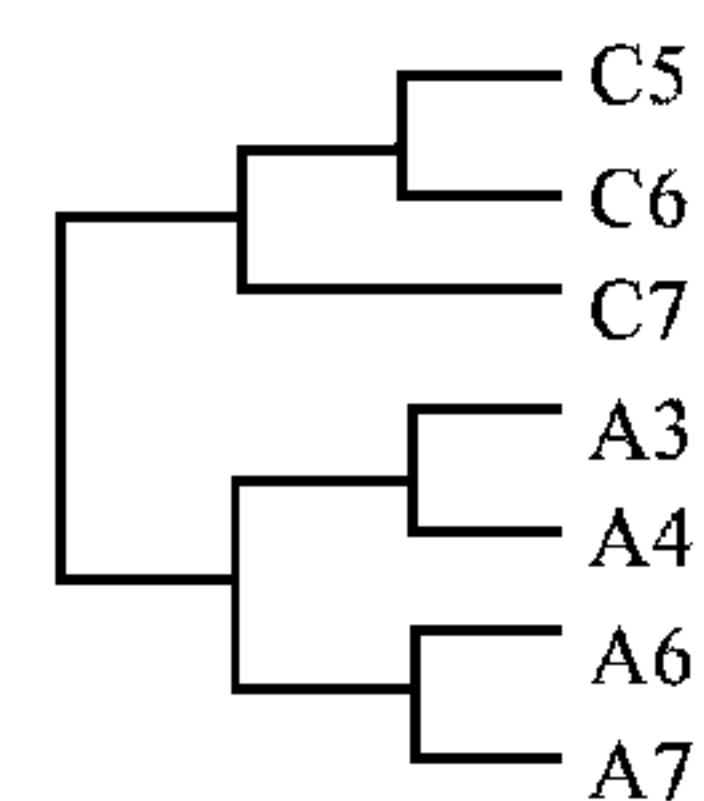
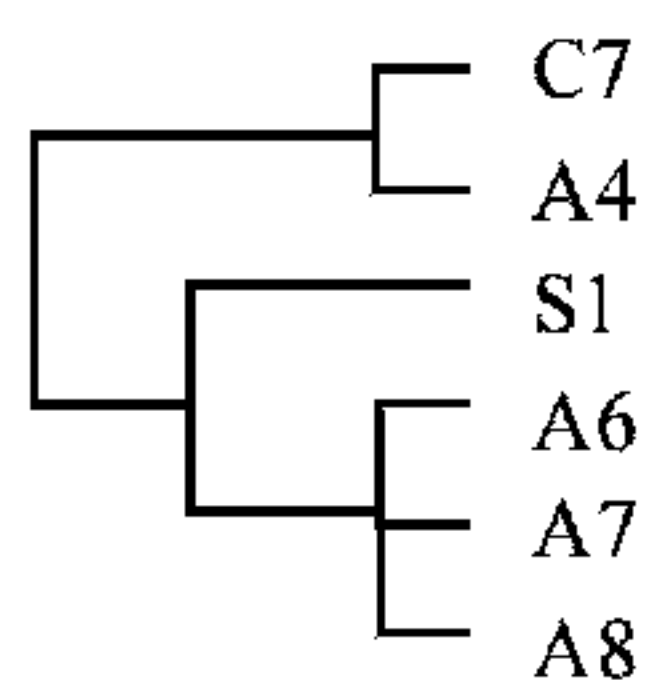
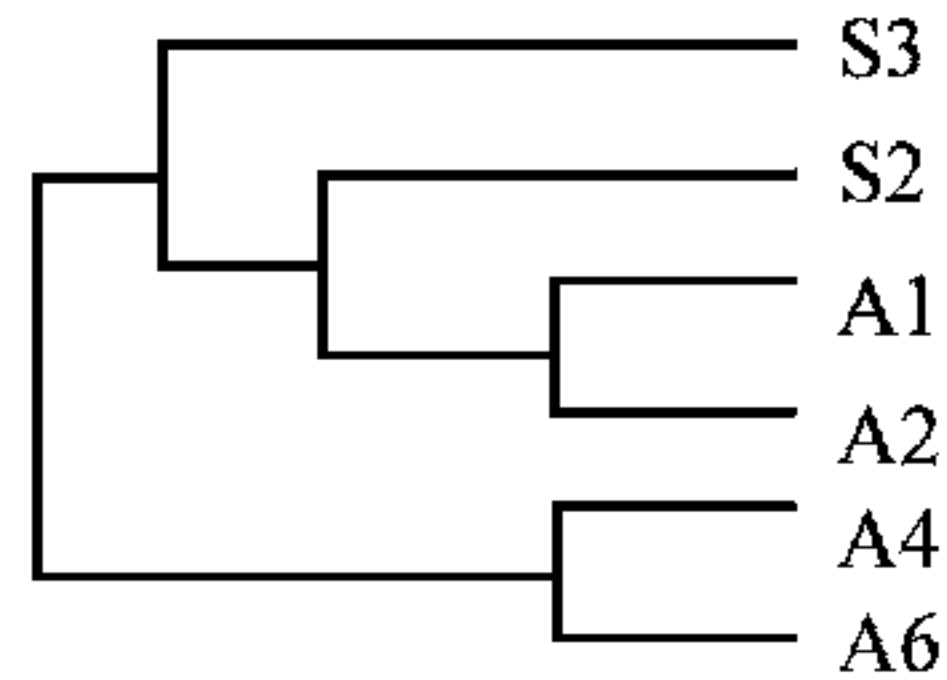
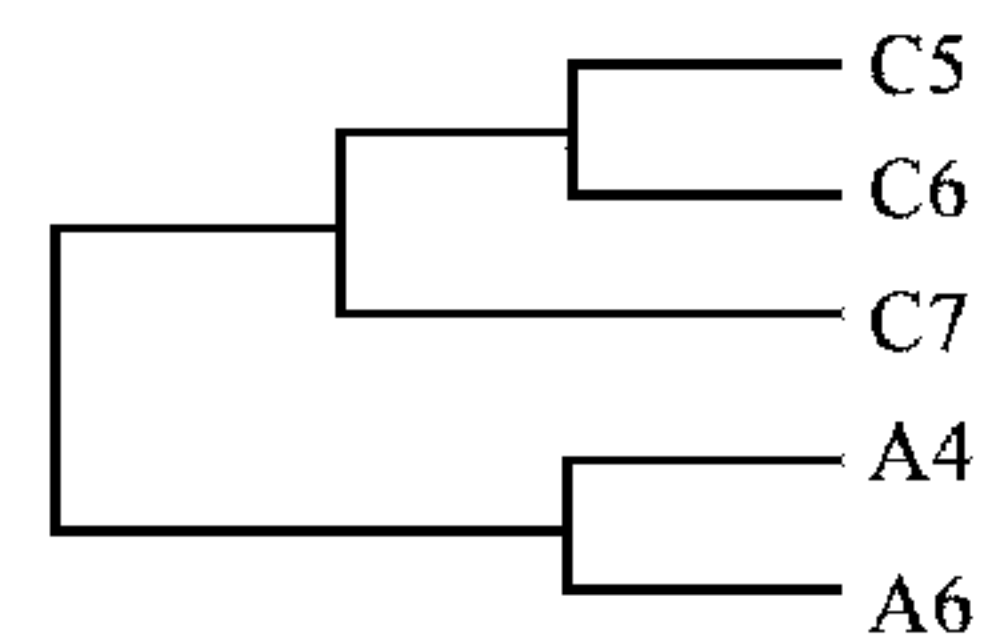
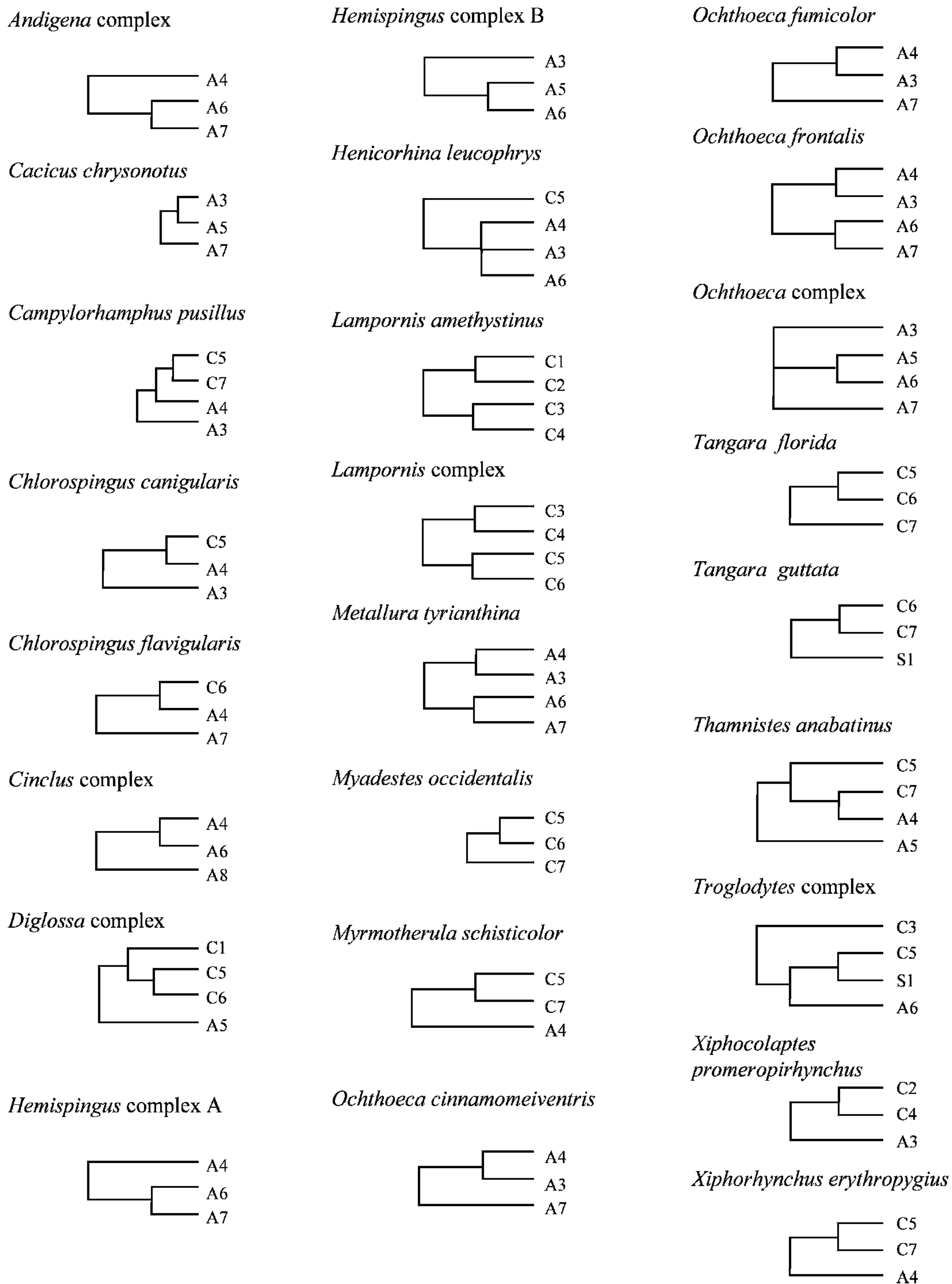

Figure 4. Continued.

Ecologically stable areas are represented by the intervening slopes between river valleys that remained forested throughout glacial and interglacial cycles.

Almost 50% (16 of 34) of populations from adjacent endemism regions separated by river valleys date to the

last 1 million years (Fig. 7), suggesting that the intense glacial cycles during the mid and late Pleistocene may have resulted in repeated episodes of range expansion across river valley barriers, followed by isolation by those barriers. However, a large proportion (11 of 36) of

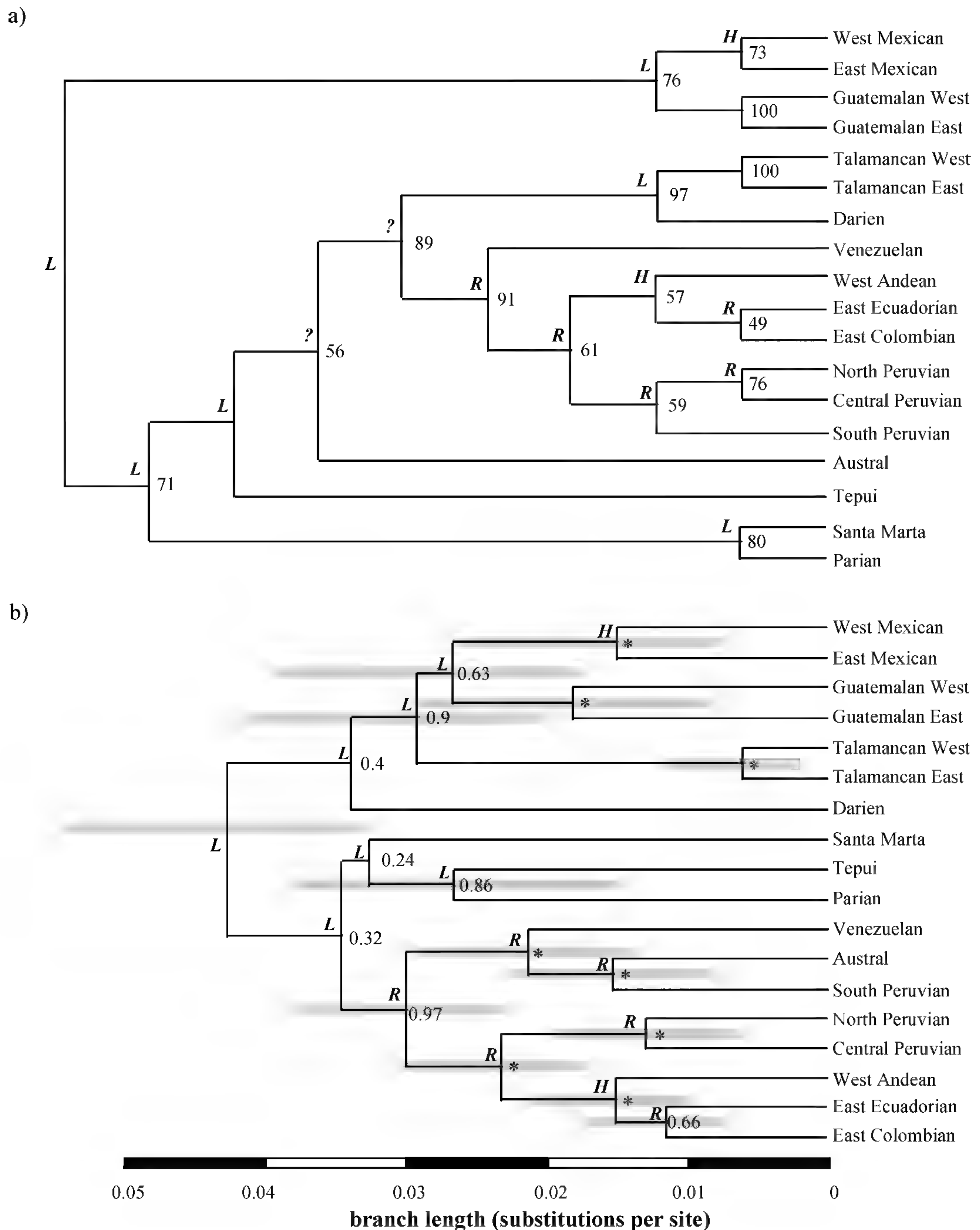

Figure 5. Supertree area cladogram (A) and sequence concatenation area cladogram (B) for Neotropical montane forest zoogeographic species. Support indices are shown to the right of nodes. Bootstrap values are shown for the supertree area cladogram and posterior probabilities for the sequence concatenation area cladogram. Posterior probability of 1.0 shown by asterisk (*). Ninety-five percent confidence intervals for node ages shown only for the sequence concatenation area cladogram. Lowland barriers indicated by *L*, highland barriers by *H*, and river valley barriers by *R*.

divergence events across river valley barriers predate the late Pliocene and Pleistocene glacial cycles altogether (2.4 Ma to recent; Fig. 7), demonstrating that glacial cycles alone were not responsible for all

divergence events across river valleys. These results are consistent with the long-term role played by arid river valleys in promoting differentiation between regions of endemism.

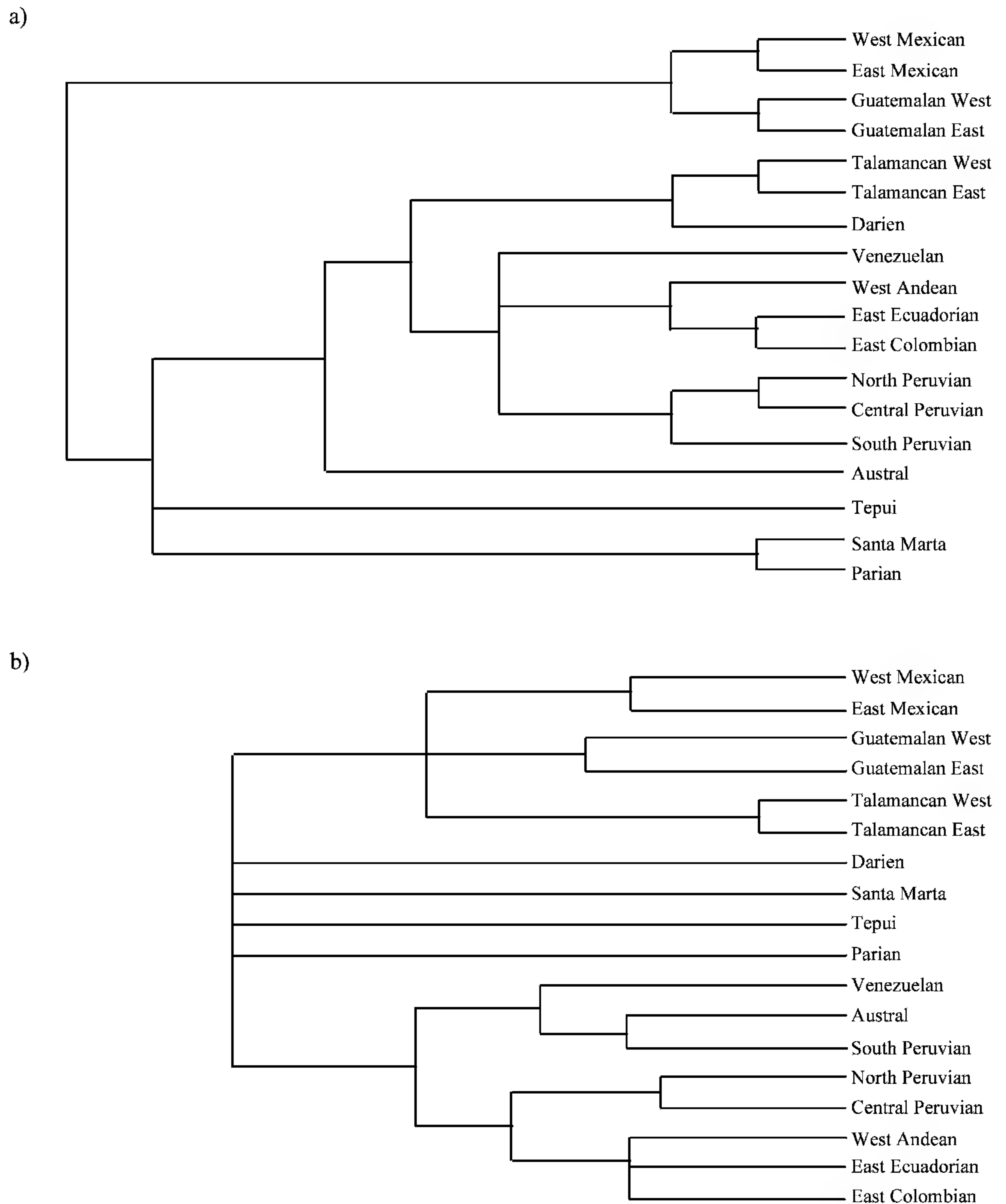

Figure 6. Cladograms showing only nodes with greater than 70% bootstrap support for the supertree area cladogram (A) and greater than 0.95 posterior probability for the sequence concatenation area cladogram (B).

THE ROLE OF DISPERSAL AND VICARIANCE

The role of dispersal and vicariance in promoting the formation of patterns of endemism is widely debated (e.g., Zink et al., 2000). A number of highland species or species complexes are derived from lowland source faunas. This has most often been interpreted as speciation following dispersal from

lowland to highland regions (i.e., Weir, 2006; Brumfield & Edwards, 2007). However, Ribas et al. (2007) recently suggested that highland populations were originally distributed at low elevations, but were gradually uplifted and vicariantly isolated from adjacent lowland populations during orogeny of the Eastern Cordillera of the Andes. Although such a vicariant scenario may have played a role in the origin

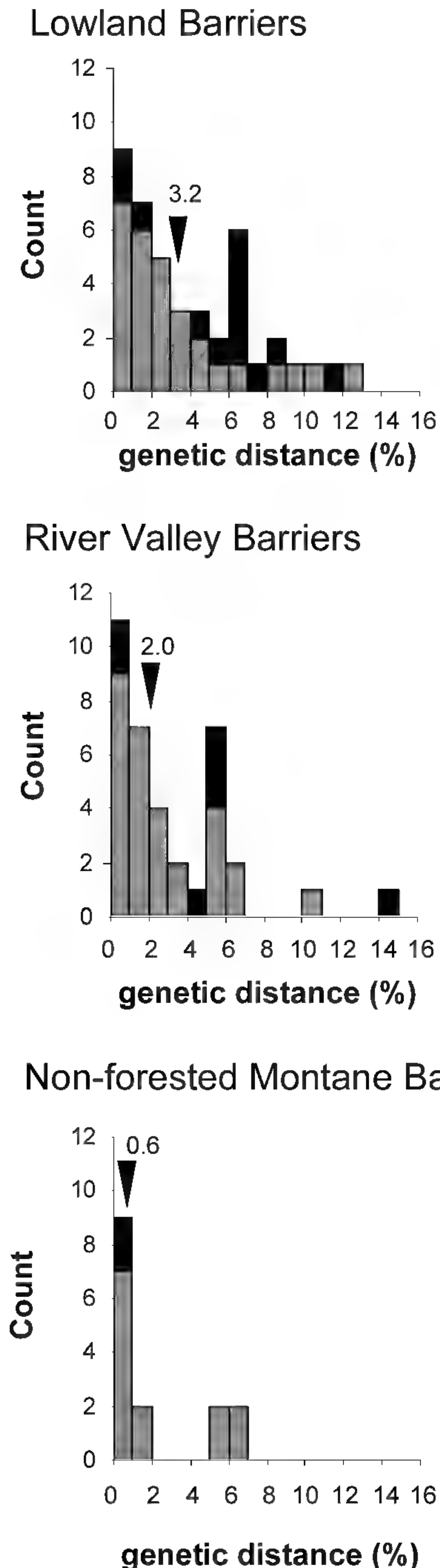

Figure 7. Genetic distances between adjacent regions of endemism separated by lowland, river valley, and nonforested montane barriers. Median values shown by arrows. Distances between species-level taxa are shown in black and between conspecific populations in gray.

of certain highland clades, most highland zoogeographic species complexes lack lowland components, suggesting they have diversified solely within Neotropical highland regions. Vicariant isolation from

lowland ancestors is highly unlikely for divergence events within the zoogeographic species complexes included in this data set.

Other possible modes of vicariance include the development of river valleys or uplift of highland regions above the tree line. Formation of such barriers in the Andes may have simultaneously fragmented the ranges of co-distributed species, resulting in populations with similar ages along either side of the barrier. A burst of divergence events should date to the time of barrier formation. For taxa isolated on one side of a barrier, dispersal across the barrier could produce founder populations at any time following barrier formation. The combination of initial vicariance and subsequent founder events would result in a burst of events dating to the time of barrier formation followed by a series of subsequent events up to the present.

Unfortunately, the geologic literature does not provide specific dates for the formation of Andean river valleys. Given that extensive uplift of highland regions along the eastern edge of the Andes occurred throughout the past 10 million years in Ecuador and Peru and the past 5 million years in Colombia (Gregory-Wodzicki, 2000) and Venezuela (Audemard, 2003; Dhont et al., 2005), river valleys in these regions almost certainly date to these time periods. The wide span of divergence dates for most river valley barriers suggests that a protracted history of dispersal was the predominant mode by which the current fauna in highland regions of endemism originated. Sample sizes are too small to detect bursts of divergence dates associated with formation of most river barriers, but this may be possible as other species are investigated. However, divergence across the Río Marañón might conform to such a pattern (Fig. 3I, J). The Río Marañón is characterized by a burst of divergence events around 3 Ma followed by a smaller number of divergence events up to the present.

In contrast to the wide range of divergence dates associated with most river valley barriers, almost all populations isolated on either slope of the northern Andes date to the past 1 million years. This recent burst suggests either some ongoing gene flow or very recent isolation between these slopes. The latter seems likely, as Pleistocene glacial cycles were severe in the Andes only during the past 0.9 million years, and glaciation at high altitudes likely provided a hard barrier to gene flow, vicariantly separating populations along the eastern and western slopes (Weir, 2006).

CONSENSUS AREA CLADOGRAMS

The SAC and SCAC methods produced different topologies (Figs. 5, 6), and interpretation of the patterns uncovered is not straightforward. Still,

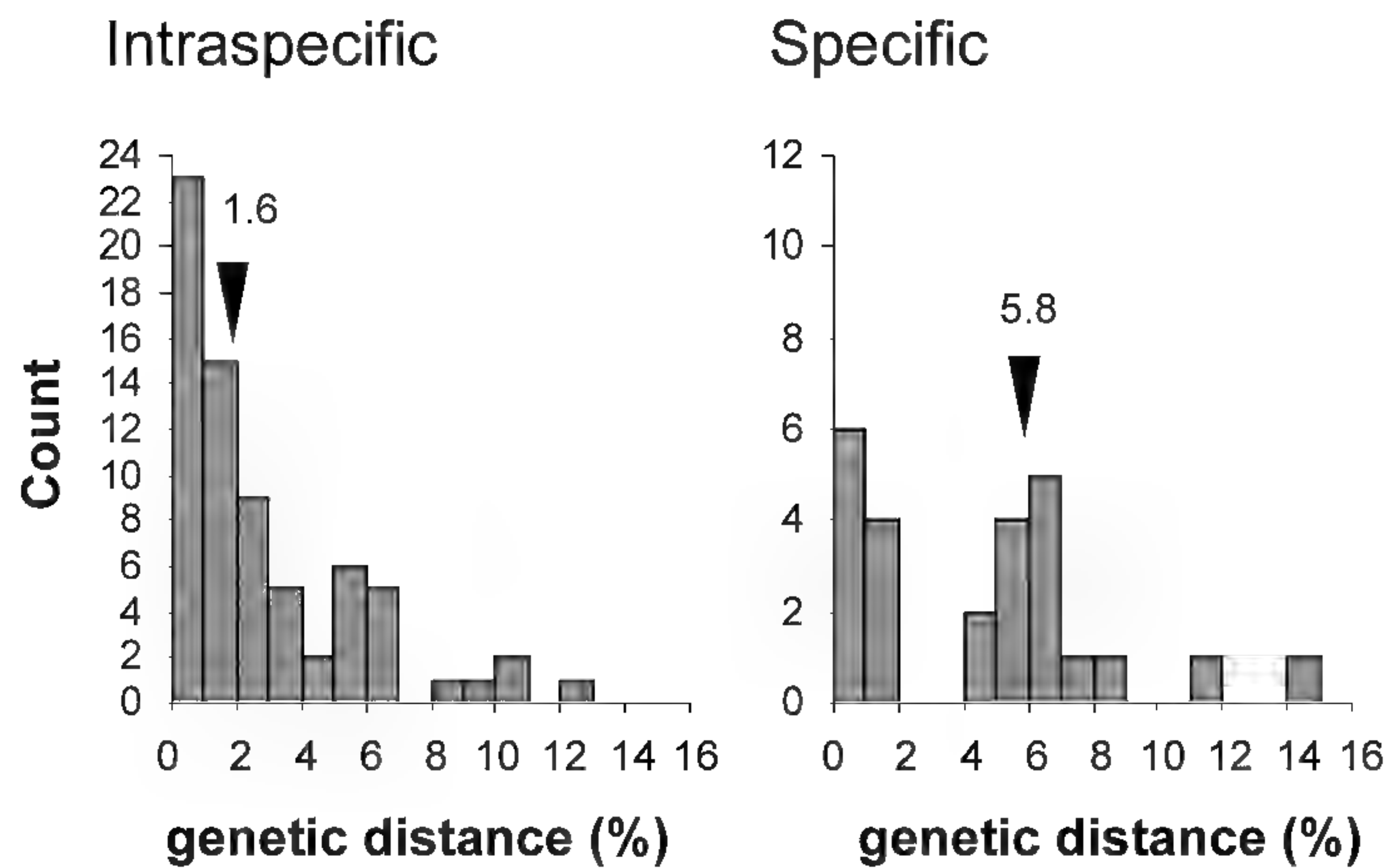

Figure 8. Genetic distances between adjacent regions of endemism for taxa differentiated at the species level and intraspecific taxa. Median values are shown by arrows. Distances between species-level taxa are shown in black and between conspecific populations in gray.

branching patterns shared in common by the two methods highlight some key points. First, both methods suggest that the basal divergence event in montane forest taxa occurred somewhere between the north Andes and Nicaragua. In the SAC topology, this break occurs north and south of the Nicaraguan lowlands, while in the SCAC topology it occurs across the lowland barrier that separates the Darién from the Andes. This basal break suggests the presence of two or more distinct montane forest source faunas for the Neotropics, one in North America (i.e., Mexico, Middle America) and one or more in South America.

The biogeographic placement of this basal break just north (SAC) or just south (SCAC) of the Isthmus of Panama suggests that the narrow isthmuses that separate the North and South American continents formed an important barrier for highland birds. This basal (or near basal) split is also reflected in the topologies of a large proportion of individual zoogeographic species complexes (Fig. 4). A few of these complexes dispersed between North and South America before land bridge completion, when marine channels still bisected these isthmuses, while most dispersed at or after its final uplift (Figs. 2C, 3A). In source trees, Darién and Talamancan highland regions share affinities with highland regions to the north in some zoogeographic species and highland regions to the south in others (Fig. 4). In the two area cladogram methods, the conflicting placement of the Talamanca and Darién highlands in either the North or South American clades likely reflects this mixed ancestry for zoogeographic species complexes invading these recently uplifted highland regions along the land bridge.

In both analyses, the Parian, Santa Marta, and tepui regions—isolated from each other and the Andes by

lowland regions—are basal within the predominantly South American clade. Within the Andes, relationships between regions of endemism were poorly resolved in the SAC method but well resolved in the SCAC method (Fig. 6). The SCAC topology supports a monophyletic Andean clade but suggests a curious connection between the Venezuelan region and the Austral and south Peruvian regions despite the fact that four geographically intervening regions separate these regions. This unusual relationship is likely driven by the *Chlorospingus ophthalmicus* complex, whose Venezuelan representative shares high sequence similarity to representatives from the Austral region despite a series of genetically differentiated and geographically intermediate populations (Fig. 4; Weir et al., 2008).

In the SCAC topology, the west Andean, east Ecuadorian, and east Colombian regions formed a well-supported clade in the north Andes. This clade was sister to a clade containing the north and central Peruvian regions with the Río Marañón forming the barrier between them. Basal to these was the clade containing the south Peruvian, Austral, and Venezuelan regions. Ignoring the unusual placement of the Venezuelan region, the basal placement of the southernmost Andean regions is consistent with a biogeographic history of northward expansion. Beginning with a source fauna in the southern Andes, northward expansion may have occurred in a stepwise fashion, first across the Río Apurímac, and then across the Río Marañón. Given the geologically younger ages for uplift of many highland regions in the north Andes, with uplift occurring in some regions (i.e., the east Colombian region) as recently as 3 Ma, expansion into these regions from a South Andean

source fauna is not unreasonable. Alternatively, a vicariant history may explain this pattern with formation of the Río Apurímac forming the initial vicariant event followed by subsequent formation of the Río Marañón. While the burst of divergence events across the Río Marañón near 3 Ma (Fig. 3I, J) may suggest a vicariant event, a clear burst is not detected for the Río Apurímac.

Relationships in Middle America and Mexico are not well resolved for deeper nodes, but do strongly suggest that subregions within each highland block formed monophyletic assemblages. Lowland barriers separate these monophyletic clades within highland regions from each other.

Nodes represented by lowland barriers generally occurred deepest in the SAC and SCAC phylogenies (Fig. 5), with nodes spanning river and highland barriers occurring in more derived positions. These results further demonstrate that lowland barriers have played the most important role in diversification of Neotropical highland birds.

CONSERVATION IMPLICATIONS

Highland montane forest regions of endemism were defined on the basis of endemic species in each of these regions (Cracraft, 1985; Stotz et al., 1996; Stattersfield et al., 1998). This study demonstrates that a large proportion of populations within widespread species possess genetically differentiated populations in many of these regions of endemism (Fig. 8), emphasizing the value of preserving tracts of highland forest in each. Genetic differentiation was greatest between highland regions separated by lowland barriers and by deep, arid river valleys. Regions of endemism on either side of these barriers have a high conservation priority. With the sole exception of the division between the east Colombian and east Ecuadorian regions, all geographically proximate regions of endemism had at least one divergence date greater than 2 Ma (assuming a standard 2% clock), and most had intraspecific splits greater than 2 Ma. Dates for intraspecific splits between adjacent highland regions ranged as high as 6.5 Ma. It is important to note that almost half (32 of 70) of all intraspecific divergence events between adjacent highland regions (Fig. 8) occurred more than 1 Ma and one third (23 of 70) occurred more than 2 Ma, demonstrating substantial isolation of populations in these regions.

The extensive genetic differentiation between conspecific populations in highland regions of endemism demonstrates that currently defined species boundaries do not adequately represent all evolutionarily distinct lineages. Under the biologic species

concept (Price, 2007), this is not an issue because biologic species may contain multiple genetically differentiated taxa provided those populations are not reproductively isolated. Under the biologic species concept, genetically differentiated populations should be managed as separate evolutionary significant units (Vogler & DeSalle, 1994). Under the phylogenetic species concept (Price, 2007), these results suggest that many currently defined highland species contain multiple, unrecognized species. As the biologic species concept is currently favored (although species definitions are arbitrary for many allopatric populations) by the South American Classification Committee (Renssen et al., 2007) for South American birds and the American Ornithologists' Union (American Ornithologists' Union, 1998) for North and Central American birds, it is important that governments treat evolutionarily significant units rather than species-level taxa as the basic units of conservation.

Given the narrow altitudinal distributions of many montane species, it may be necessary to preserve large tracts of intact forest in order to maintain substantial population sizes. However, extensive deforestation threatens the continuity of forest tracts within montane regions. Continued development of road systems and slash-and-burn agricultural practices are primarily responsible. Ironically, government control of illicit crops accelerates montane deforestation as drug growers are forced to clear additional land along higher, more inaccessible slopes (Fjeldså et al., 2005). Existing forest tracts are rapidly disappearing from many montane regions of endemism. In the Andean region as a whole, less than 10% of montane forest is estimated to be intact (Henderson et al., 1991). The percentage is lower in some regions of endemism, with less than 4% of forest remaining intact in the west Andean region (Dodson & Gentry, 1991). The key finding reported here, that many widespread montane forest species are composed of multiple genetically differentiated populations in geographically localized areas of endemism, shows that a failure to adequately preserve remaining montane forest tracts within each region of endemism will result in the loss of much greater diversity than predicted from a straightforward taxonomic analysis.

Literature Cited

- Aleixo, A. 2002. Molecular systematics and the role of the "varzea"—"terra-firme" ecotone in the diversification of *Xiphorhynchus* woodcreepers (Aves: Dendrocolaptidae). *Auk* 119: 621–640.
- American Ornithologists' Union. 1998. Check-list of North American Birds, 7th ed. American Ornithologists' Union, Washington, D.C.

- Anderson, T. H. 1969. First evidence for glaciation in Sierra Los Cuchumatanes Range, north-western Guatemala. *Special Pap. Geol. Soc. Amer.* 121: 387.
- Audemard, F. A. 2003. Geomorphic and geologic evidence of ongoing uplift and deformation in the Merida Andes, Venezuela. *Quatern. Int.* 101: 43–65.
- Barker, F. K. & S. M. Lanyon. 2000. The impact of parsimony weighting schemes on inferred relationships among toucans and neotropical barbets (Aves: Piciformes). *Molec. Phylogen. Evol.* 15: 215–234.
- Baum, B. R. 1992. Combining trees as a way of combining data sets for phylogenetic inference, and the desirability of combining gene trees. *Taxon* 41: 3–10.
- Bennett, K. D. 1990. Milankovitch cycles and their effects on species in ecological and evolutionary time. *Paleobiology* 16: 11–21.
- Bininda-Emonds, O. R. P. 2004. The evolution of supertrees. *Trends Ecol. Evol.* 19: 315–322.
- & H. N. Bryant. 1998. Properties of matrix representation with parsimony analyses. *Syst. Biol.* 47: 497–508.
- & M. J. Sanderson. 2001. Assessment of the accuracy of matrix representation with parsimony analysis supertree construction. *Syst. Biol.* 50: 565–579.
- Brumfield, R. T. & S. V. Edwards. 2007. Evolution into and out of the Andes: A Bayesian analysis of historical diversification in *Thamnophilus antshrikes*. *Evolution* 61: 346–367.
- Burns, K. J. 1997. Molecular systematics of tanagers (Thraupinae): Evolution and biogeography of a diverse radiation of Neotropical birds. *Molec. Phylogen. Evol.* 8: 334–348.
- & K. Naoki. 2004. Molecular phylogenetics and biogeography of Neotropical tanagers in the genus *Tangara*. *Molec. Phylogen. Evol.* 32: 838–854.
- Cadena, C. D., J. Klicka & R. E. Ricklefs. 2007. Evolutionary differentiation in the Neotropical montane region: Molecular phylogenetics and phylogeography of *Buarremon* brush-finches (Aves, Emberizidae). *Molec. Phylogen. Evol.* 44: 993–1016.
- Coates, A. G. & J. A. Obando. 1996. The geologic evolution of the Central American isthmus. Pp. 21–56 in J. B. C. Jackson, A. F. Budd & A. G. Coates (editors), *Evolution and Environment in Tropical America*. University of Chicago Press, Chicago.
- , J. B. C. Jackson, L. S. Collins, T. M. Cronin, H. J. Dowsett, L. M. Bybell, P. Jung & J. A. Obando. 1992. Closure of the Isthmus of Panama—The near-shore marine record of Costa Rica and western Panama. *Bull. Geol. Soc. Amer.* 104: 814–828.
- Coyne, J. & T. Price. 2000. Little evidence for sympatric speciation in island birds. *Evolution* 54: 2166–2171.
- Cracraft, J. 1985. Historical biogeography and patterns of differentiation within the South American avifauna: Areas of endemism. *Neotrop. Ornithol.* 36: 49–84.
- Dhont, D., G. Backe & Y. Hervouet. 2005. Plio-Quaternary extension in the Venezuelan Andes: Mapping from SAR JERS imagery. *Tectonophysics* 399: 293–312.
- Dingle, C., I. J. Lovette, C. Canaday & T. B. Smith. 2006. Elevational zonation and the phylogenetic relationships of the *Henicorhina* wood-wrens. *Auk* 123: 119–134.
- Dodson, C. H. & A. H. Gentry. 1991. Biological extinction in western Ecuador. *Ann. Missouri Bot. Gard.* 78: 273–295.
- Drummond, A. J. & A. Rambaut. 2007. BEAST: Bayesian evolutionary analysis by sampling trees. *BMC Evol. Biol.* 7: 214.
- Fjeldså, J. 1995. Geographic patterns of neoendemic and older relict species of Andean forest birds: The significance of ecologically stable areas. Pp. 89–102 in S. P. Churchill, H. Balslev, E. Forero & J. L. Luteyn (editors), *Biodiversity and Conservation of Neotropical Montane Forests*. New York Botanical Garden, Bronx.
- & N. Krabbe. 1990. *Birds of the High Andes: A Manual to the Birds of the Temperate Zone of the Andes and Patagonia, South America*. Apollo Books, Copenhagen.
- & J. C. Lovett. 1997. Biodiversity and environmental stability. *Biodivers. & Conservation* 6: 315–323.
- , D. Ehrlich, E. Lambin & E. Prins. 1997. Are biodiversity ‘hotspots’ correlated with current ecoclimatic stability? A pilot study using the NOAA-AVHRR remote sensing data. *Biodivers. & Conservation* 6: 401–422.
- , E. Lambin & B. Mertens. 1999. Correlation between endemism and local ecoclimatic stability documented by comparing Andean bird distributions and remotely sensed land surface data. *Ecography* 22: 63–78.
- , M. D. Alvarez, J. M. Lazcano & B. Leon. 2005. Illicit crops and armed conflict as constraints on biodiversity conservation in the Andes region. *Ambio* 34: 205–211.
- Garcia-Moreno, J., P. Arctander & J. Fjeldså. 1998. Pre-Pleistocene differentiation among chat-tyrants. *Condor* 100: 629–640.
- , ——— & ———. 1999. A case of rapid diversification in the neotropics: Phylogenetic relationships among *Cranioleuca* spinetails (Aves, Furnariidae). *Molec. Phylogen. Evol.* 12: 273–281.
- , J. Ohlson & J. Fjeldså. 2001. MitDNA sequences support monophyly of *Hemispingus* tanagers. *Molec. Phylogen. Evol.* 21: 424–435.
- , N. Cortes, G. M. Garcia-Deras & B. E. Hernandez-Banos. 2006. Local origin and diversification among *Lampornis* hummingbirds: A Mesoamerican taxon. *Molec. Phylogen. Evol.* 38: 488–498.
- Gentry, A. H. 1986. Species richness and floristic composition of Chocó region plant communities. *Caldasia* 15: 71–91.
- . 1992. Tropical forest biodiversity—Distributional patterns and their conservational significance. *Oikos* 63: 19–28.
- Grafe, K., W. Frisch, I. M. Villa & M. Meschede. 2002. Geodynamic evolution of southern Costa Rica related to low-angle subduction of the Cocos Ridge: Constraints from thermochronology. *Tectonophysics* 348: 187–204.
- Gregory-Wodzicki, K. M. 2000. Uplift history of the central and northern Andes: A review. *Bull. Geol. Soc. Amer.* 112: 1091–1105.
- Hackett, S. J. 1995. Molecular systematics and zoogeography of flowerpiercers in the *Diglossa baritula* complex. *Auk* 112: 156–170.
- Heine, K. 1988. Late Quaternary glacial chronology of the Mexican volcanoes. *Die Geowissenschaften* 7: 197–205.
- Henderson, A., S. P. Churchill & J. L. Luteyn. 1991. Neotropical plant diversity. *Nature* 351: 21–22.
- Hooghiemstra, H. & A. M. Cleff. 1995. Pleistocene climatic change and environment and generic dynamics in the North Andean montane forest and paramo. Pp. 35–49 in S. P. Churchill, H. Balslev, E. Forero & J. L. Luteyn (editors), *Biodiversity and Conservation of Neotropical Montane Forests*. New York Botanical Garden, Bronx.

- & T. van der Hammen. 2004. Quaternary Ice-Age dynamics in the Colombian Andes: Developing an understanding of our legacy. *Philos. Trans., Ser. B* 359: 173–180.
- , J. L. Melice, A. Berger & N. J. Shackleton. 1993. Frequency-spectra and paleoclimatic variability of the high-resolution 30 1450 ka Funza I pollen record (Eastern Cordillera, Colombia). *Quatern. Sci. Rev.* 12: 141–156.
- Irestedt, M., J. Fjeldså & P. G. P. Ericson. 2004. Phylogenetic relationships of woodcreepers (Aves: Dendrocolaptinae)—Incongruence between molecular and morphological data. *J. Avian Biol.* 35: 280–288.
- Klicka, J. & G. M. Spellman. 2007. A molecular evaluation of the North American “grassland” sparrow clade. *Auk* 124: 537–551.
- Kreft, H. & W. Jetz. 2007. Global patterns and determinants of vascular plant diversity. *Proc. Natl. Acad. Sci. U.S.A.* 104: 5925–5930.
- Lachniet, M. S. & G. O. Seltzer. 2002. Late Quaternary glaciation of Costa Rica. *Bull. Geol. Soc. Amer.* 114: 547–558.
- Lovette, I. J. 2004. Mitochondrial dating and mixed support for the “2% rule” in birds. *Auk* 121: 1–6.
- Mayr, E. & L. L. Short. 1970. *Species Taxa of North American Birds: A Contribution to Comparative Systematics*. Nuttall Ornithological Club, Cambridge, Massachusetts.
- & J. Diamond. 2001. *The Birds of Northern Melanesia: Speciation, Ecology, and Biogeography*. Oxford University Press, Oxford.
- Miller, M. J., E. Bermingham & R. E. Ricklefs. 2007. Historical biogeography of the new world solitaires (*Myadestes* spp.). *Auk* 124: 868–885.
- Moyle, R. G. 2004. Phylogenetics of barbets (Aves: Piciformes) based on nuclear and mitochondrial DNA sequence data. *Molec. Phylogen. Evol.* 30: 187–200.
- Nahum, L. A., S. L. Pereira, F. M. C. Fernandes, S. R. Matioli & A. Wajntal. 2003. Diversification of Ramphastinae (Aves, Ramphastidae) prior to the Cretaceous/Tertiary boundary as shown by molecular clock of mtDNA sequences. *Genet. Molec. Biol.* 26: 411–418.
- Newton, I. 2003. *The Speciation and Biogeography of Birds*. Academic Press, Amsterdam.
- O'Neill, J. P. 1992. A general overview of the montane avifauna of Peru. *Mem. Mus. Hist. Nat. “Javier Prado”* 21: 47–55.
- Outlaw, D. C., G. Voelker, B. Mila & D. J. Girman. 2003. Evolution of long-distance migration in and historical biogeography of *Catharus* thrushes: A molecular phylogenetic approach. *Auk* 120: 299–310.
- Perez-Eman, J. L. 2005. Molecular phylogenetics and biogeography of the Neotropical redstarts (*Myioborus*; Aves, Parulinae). *Molec. Phylogen. Evol.* 37: 511–528.
- Phillimore, A. B., C. D. L. Orme, G. H. Thomas, T. M. Blackburn, P. M. Bennett, K. J. Gaston & I. P. F. Owens. 2008. Sympatric speciation in birds is rare: Insights from range data and simulations. *Amer. Naturalist* 171: 646–657.
- Price, J. J. & S. M. Lanyon. 2004. Song and molecular data identify congruent but novel affinities of the Green Oropendola (*Psarocolius viridis*). *Auk* 121: 224–229.
- Price, T. 2007. *Speciation in Birds*. Roberts and Company Publishers, Greenwood Village, Colorado.
- Purvis, A. 1995. A modification to Baum and Ragans method for combining phylogenetic trees. *Syst. Biol.* 44: 251–255.
- Rambaut, A. 2007. FigTree. <<http://tree.bio.ed.ac.uk/software/figtree/>>, accessed 23 June 2009.
- Remsen, J. V., C. D. Cadena, A. Jaramillo, M. Nores, J. F. Pacheco, M. B. Robbins, T. S. Schulenberg, F. G. Stiles, D. F. Stotz & K. J. Zimmer. 2007. A classification of the bird species of South America. American Ornithologists' Union, Washington, D.C., <<http://www.museum.lsu.edu/~Remsen/SACCBaseline.html>>, accessed 15 December 2007.
- Ribas, C. C., R. G. Moyle, C. Y. Miyaki & J. Cracraft. 2007. The assembly of montane biotas: Linking Andean tectonics and climatic oscillations to independent regimes of diversification in *Pionus* parrots. *Proc. Royal Soc. London, Ser. B, Biol. Sci.* 274: 2399–2408.
- Rice, N. H., A. T. Peterson & G. Escalona-Segura. 1999. Phylogenetic patterns in montane *Troglodytes* wrens. *Condor* 101: 446–451.
- Rosenzweig, M. L. 1995. *Species Diversity in Space and Time*. Cambridge University Press, Cambridge, United Kingdom.
- Simpson, G. G. 1980. *Splendid Isolation: The Curious History of South American Mammals*. Yale University Press, New Haven, Connecticut.
- Stattersfield, A. J., M. J. Crosby, A. J. Long & D. C. Wege. 1998. *Endemic Bird Areas of the World*. Birdlife International, Cambridge, United Kingdom.
- Stehli, F. & S. Webb. 1985. *The Great American Biotic Interchange*. Plenum Press, New York.
- Stotz, D. F., J. W. Fitzpatrick, T. A. Parker & D. K. Moskowitz. 1996. *Neotropical Birds: Ecology and Conservation*. University of Chicago Press, Chicago.
- Strewe, R., C. Navarro & C. J. Villa-De Leon. 2006. Conservation of the endemic birds of the Sierra Nevada de Santa Marta massif, Colombia. *J. Ornithol.* 147: 258–259.
- Swofford, D. L. 2002. PAUP* 4.0b10: Phylogenetic Analysis Using Parsimony (*and Other Methods). Sinauer Associates, Sunderland, Massachusetts.
- Valencia, R., N. Pitman, S. León-Yáñez & P. M. Jørgensen. 2000. *Libro Rojo de las Plantas Endémicas del Ecuador 2000*. Herbario QCA, Pontificia Universidad Católica del Ecuador, Quito.
- Van't Veer, R. & H. Hooghiemstra. 2000. Montane forest evolution during the last 650 000 yr in Colombia: A multivariate approach based on pollen record Funza-I. *J. Quatern. Sci.* 15: 329–346.
- Voelker, G. 2002. Molecular phylogenetics and the historical biogeography of dippers (*Cinclus*). *Ibis* 144: 577–584.
- , S. Rohwer, R. C. K. Bowie & D. C. Outlaw. 2007. Molecular systematics of a speciose, cosmopolitan songbird genus: Defining the limits of, and relationships among, the *Turdus* thrushes. *Molec. Phylogen. Evol.* 42: 422–434.
- Vogler, A. P. & R. DeSalle. 1994. Diagnosing units of conservation management. *Conservation Biol.* 8: 354–363.
- Vuilleumier, F. 1969. Pleistocene speciation in birds living in the high Andes. *Nature* 1179–1180.
- . 1980. Speciation in birds of the high Andes. *Acta XVII Congressus Internationalis Ornithologici* 2: 1256–1261.
- Webb, S. 1985. Late Cenozoic mammal dispersals between the Americas. Pp. 357–386 in F. Stehli & S. Webb (editors), *The Great American Biotic Interchange*. Plenum Press, New York.
- Weckstein, J. D. 2005. Molecular phylogenetics of the ramphastid toucans: Implications for the evolution of morphology, vocalizations, and coloration. *Auk* 122: 1191–1209.
- Weir, J. T. 2006. Divergent timing and patterns of species accumulation in lowland and highland Neotropical birds. *Evolution* 60: 842–855.

-
- & D. Schluter. 2004. Ice sheets promote speciation in boreal birds. *Proc. Royal Soc. London, Ser. B, Biol. Sci.* 271: 1881–1887.
- & ———. 2008. Calibrating the avian molecular clock. *Molec. Ecol.* 17: 2321–2328.
- , E. Bermingham, M. J. Miller, J. Klicka & M. A. Gonzales. 2008. Phylogeography of a morphologically diverse Neotropical montane species, the common bush-tanager (*Chlorospingus ophthalmicus*). *Molec. Phylogen. Evol.* 47: 650–664.
- White, S. E. & S. Valastro. 1984. Pleistocene glaciation of Volcano Ajusco, Central Mexico, and comparison with the standard Mexican glacial sequence. *Quatern. Int.* 21: 21–35.
- Winker, K. & C. L. Pruett. 2006. Seasonal migration, speciation, and morphological convergence in the genus *Catharus* (Turdidae). *Auk* 123: 1052–1068.
- Zink, R. M., R. C. Blackwell-Rago & F. Ronquist. 2000. The shifting roles of dispersal and vicariance in biogeography. *Proc. Royal Soc. London, Ser. B, Biol. Sci.* 267: 497–503.

MOSS DIVERSITY AND ENDEMISM OF THE TROPICAL ANDES¹

Steven P. Churchill²

ABSTRACT

The mosses of the tropical Andes are examined to determine a conservative estimate of diversity, excluding a significant number of unconfirmed names and dubious reports that have distorted estimates in the past. In this analysis, 1376 species represented by 327 genera and 69 families are recognized. Within this cohort, species endemism for the tropical Andes is estimated at 31%. Regionally, the number of mosses restricted to the northern Andes (321 species) is higher than the number restricted to the central Andes (241 species). Regional endemism exhibits a similar pattern: more endemics in the northern Andes (155 species) than in the central Andes (129 species).

Key words: Diversity, endemism, mosses, tropical Andes.

The tropical Andes are widely acknowledged as one of the world's great centers of biodiversity (Rodríguez-Mahecha et al., 2004). Species richness is one of the criteria that serves to rank the tropical Andes as a major focal point of biodiversity. Other criteria include the level of endemism and past and current environmental degradation (Orme et al., 2005). The very foundation of biodiversity is our knowledge of the organisms. Precise estimates of diversity for most major groups of organisms are, however, elusive for the tropical Andes. It is very likely that diversity and distribution within this region are only well known for birds and mammals; all other estimates—for fungi, plants, and insects, for example—are only vague or approximate. This is due, in part, to required ongoing basic exploration, inventory, discovery of new species, and, most critical to our understanding of diversity, revisionary studies.

Mosses represent just one group of organisms that make the tropical Andes one of the great centers of biodiversity in the world. This region contains about 15%–17% of the estimated 8000 to 9000 mosses in the world. Endemism is relatively high, with 31% of the species considered to be unique to the region (see below). Beyond high diversity and endemism, there is another dimension that ranks these organisms as possibly one of the most important groups in the tropical Andes. Disproportionate to their small size, mosses, rather like the ants so eloquently described by the Harvard entomologist E. O. Wilson, play a

major role in the ecosystem they occupy. Mosses, along with hepatics, are the major plant group responsible for the natural conservation of water and soil in the Andes.

The focus of this paper is an assessment of the diversity and endemism for the tropical Andean mosses. This present analysis is, in part, a reevaluation and update of a prior paper addressing moss diversity of the tropical Andes (Churchill et al., 1995). There are several moss publications since 1995 that are specifically related to the tropical Andes. The páramo mosses of Venezuela, Colombia, Ecuador, and Costa Rica were estimated at 543 species (Churchill & Griffin, 1999). The first checklist for the tropical Andean countries enumerated 2089 specific and infraspecific taxa distributed among 362 genera and 76 families (Churchill et al., 2000). A descriptive treatment of the families and genera was provided for the Neotropics (Gradstein et al., 2001) and included an analysis of bryophyte regions and habitats. Various floristic papers for each of the Andean countries are provided on the web page “Overview of Region and Countries” (<<http://mobot.mobot.org/W3T/Search/andes/overviewintro.htm>>).

OVERVIEW OF THE TROPICAL ANDES

The tropical Andes extend approximately 38 degrees of latitude, from the coastal ranges and

¹The author is much indebted to Bob Magill for his assistance in making the Tropicos database and the Andean web page a reality. My interest in and motivation for examining aspects of diversity related to tropical mosses owes a great debt to a classic article by Gentry (1982). This work was supported by grants from the National Science Foundation (DEB-9626747, DEB-0542422) and by the Taylor Fund for Ecological Research through the Missouri Botanical Garden. The author is grateful to Marshall Crosby, Victoria C. Hollowell, and Peter Jørgensen for their review of the manuscript, and to Eliana Calzadilla for preparing the maps.

²Steven P. Churchill, Missouri Botanical Garden, P.O. Box 299, St. Louis, Missouri 63166-0299, U.S.A., and Museo de Historia Natural Noel Kempff Mercado, Av. Irala 565, Casilla No. 2489, Santa Cruz, Bolivia. steve.churchill@mobot.org. doi: 10.3417/2008043

Cordillera de Mérida of Venezuela to the puna and montane ranges in northwestern Argentina. This arched backbone of South America, the longest mountain chain in the tropics, can be divided between the northern Andes (Venezuela to northernmost Peru) at 11°N to 4–5°S and the central Andes (north-central Peru to northwest Argentina) at 5°S to 27°S. The estimated area of the tropical Andes is 1,542,664 km² (Rodríguez-Mahecha et al., 2004). That figure is ca. 39% of the total area of the tropical Andean countries and slightly less than 9% of the total land surface of South America. The Amazon Basin is nearly 4.5 times larger than the tropical Andes. Useful overviews for the tropical Andes are provided on geography by Duellman (1979) and for vegetation by Luteyn and Churchill (2000).

THE MYTH OF TROPICAL MOSS DIVERSITY

It is imperative to have a clear understanding of the misconceptions that impede our knowledge of moss diversity for the tropical Andes. The year 1801 marks two important events with regard to tropical American mosses. Hedwig's opus, *Species Muscorum Frondosorum*, was published in 1801; in time this would be adopted as the official starting point of moss nomenclature, except *Sphagnum* L. This volume includes the first mosses collected in tropical America, those by Olof Swartz from the West Indies. The second event of that year occurred in the Colombian Andes; Alexander von Humboldt and Aimé Bonpland were the first to collect mosses from the Andes. These mosses were later described by William Hooker in *Musci Exotici* (1818–1820).

Historically, the most active period in which Andean mosses were collected and described occurred from about the mid-19th century to the first three decades of the 20th century. During that time period, several thousand new species were described by Europeans, beginning with Ernst Hampe, Carl Müller, William Mitten, and later Viktor Brotherus and Theodor Herzog. North Americans also began to describe species for the Andes in the first half of the 20th century, most notably Robert Williams and Edwin Bartram. The quality of these authors varied considerably. Hampe and Mitten, for the era, produced reasonably sound descriptive treatments, but at the other end of the spectrum was Müller. No single individual described more species than Müller, who was completely, or almost, indiscriminate in describing several thousand species; many of these are viewed as redundantly described species. Of the many collections sent to Müller from South America, almost all were described as new species. Unfortunately for bryology, Müller was blessed with a long life

(1818–1899), and, most detrimental to bryology, his collections housed in the Berlin herbarium were destroyed in World War II.

The recognition of species by these 19th- and early 20th-century authors was based mostly on a very narrow species concept, often defined by minute or trivial differences in morphology, e.g., plant stature, leaf shape, seta length, etc. (Pursell, 1994). Many of the described mosses were based on a very limited number of specimens and incomplete knowledge of the species described at that time by different authors. Due to the paucity of specimens, there was almost no idea of how these plants varied or how they could be differentiated from other recently described species from the same region. Other factors also contributed to the increasing confusion: communication was limited or long delayed with regard to correspondence and publications, duplicates were only later distributed if they existed, and in addition, there were various conflicts between the European nations (Kruijer, 2002).

The dilemma of excessive naming of species for the tropical regions has been discussed by Touw (1974) and Magill (1982). Those familiar with the state of tropical bryophytes stress the dire need for revisionary studies. A few examples from revisionary studies of mosses serve to exemplify the problem of excessive naming for the tropical Andes: Frahm (1991) recognized 49 species of *Campylopus* Brid. for the tropical Andes, relegating 58 previously published species to synonymy; Fransén (1995) recognized 12 species of *Bartramia* Hedw., placing 22 into synonymy; and Muñoz (1999) recognized 15 species of *Grimmia* Hedw. for the tropical Andes, with 26 previously published species relegated to synonymy. Among just these revisionary studies, 106 species were thus subtracted from the heretofore accepted mosses, or, viewed another way, the Andes lost 106 endemic species.

The compilation of checklists for mosses, either for individual countries or regions in the tropics, was an important initial phase during the late 20th century in the development of floristic knowledge. In large part, such checklists were compilations from previous floristic and revisionary studies. Embedded within these checklists were numerous species for which the taxonomic status was unknown. Checklists for all the tropical Andean countries were compiled in the 20th century: Bolivia (Herzog, 1916; Hermann, 1976), Colombia (Florschütz-de Waard & Florschütz, 1979; Churchill, 1989), Ecuador (Steere, 1948; Churchill, 1994), Peru (Menzel, 1992), and Venezuela (Pittier, 1936; Pursell, 1973). A complete summary for the tropical Andean countries was provided by Churchill et al. (2000). All of these checklists incorporated the

many newly described species, as well as the earlier dubious species reports for the tropical Andes, although adjustments to recognized species were made based on revisionary studies that existed.

A few previous studies have attempted to use data from checklists to analyze and provide generalizations and trends with regard to diversity (Churchill, 1991; Delgadillo, 1994; Churchill et al., 1995; Frahm, 2003). Given the data available, this has on occasion led to rather exaggerated species numbers. Delgadillo (1994) examined moss diversity and endemism in the Neotropics for 24 countries. Three of these countries serve as examples of inflated species numbers: Bolivia, 1182 species, with 359 endemic; Brazil, 1655 species, with 815 endemic; and Paraguay, 148 species, with 54 endemic. Although it is impressive to note that 49% of the Brazilian moss flora is endemic, 36% is endemic to Paraguay, and 30% is endemic to Bolivia, it is far from the reality. Brazil has fewer than 1000 species and probably fewer than 100 endemics, Bolivia has about 900 species and 56 endemics (see below), and, although Paraguay may have on the order of 200 species, it is highly probable that there is not a single endemic in this country (Churchill, pers. obs.). These assumptions are based on a greater knowledge gained through floristic and revisionary studies over the past two decades and on directions suggested by these results that will impact our understanding of species diversity.

There is a need then to develop a new generation of checklists for bryophytes in the tropical countries based on new stringent criteria. One of the first catalogs concerning bryophytes, in this case the hepatics for Bolivia by Gradstein et al. (2003), took a more pragmatic approach in excluding doubtful names and reports. While very few of those excluded names are now accepted, a greater portion has since been shown to be synonyms. This is a far better approach to take in future efforts of compiling bryophyte checklists particular to areas such as the Neotropics. The analysis of moss diversity and endemism of the tropical Andes will entail error, but it is better to err on the side of a conservative, realistic estimate than to err on the side of an embroidered fantasy of diversity.

Data for this analysis are derived from four sources: (1) the taxonomic treatment of the tropical Andean mosses (<<http://mobot.mobot.org/W3T/Search/andes/andesintro.htm>>, Churchill & collaborators, 2008); (2) more than 50,000 databased bryophyte collections for the Andean countries in the Missouri Botanical Garden Tropicos system; (3) a compiled world checklist for mosses by Crosby et al. (2000); and (4) recent floristic and taxonomic revisions not found on the aforementioned web page. Accepted taxa include

only legitimate names at the level of species and above. Excluded from this analysis are all species whose taxonomic status is unknown or reports considered dubious. All nomina nuda are excluded. Intraspecific categories (subspecies, varieties) are not included in the analysis. The initial species list of the tropical Andean countries (Bolivia, Colombia, Ecuador, Peru, and Venezuela) and the northwestern departments of Argentina (Jujuy, Salta, Tucumán) totaled 1974 and included 1457 accepted species and 517 excluded, most as status unknown or outside the Andean range.

A second set of data was generated from this initial effort that includes only the Andean region (Fig. 1), with the minimum elevation for the tropical Andes defined at 500 m. Outliers for the tropical Andes included in this analysis are the Cordillera de la Costa in Venezuela and the Sierra de Santa Marta in Colombia; in the south the boundary is defined to include only the departments of Jujuy, Salta, and Tucumán in northwestern Argentina. Geographically, the tepui regions (Guayana Highlands) and Atlantic and Pacific islands (e.g., Galápagos) are excluded. The adjoining coastal and interior lowlands in South America less than 500 m elevation (e.g., Amazon Basin and Chocó) are also excluded.

Data were arranged in an Excel (Microsoft Word, Redmond, Washington, U.S.A.) spreadsheet that included: name of family, genus, species, number of synonyms for each genus, elevation range, endemic status, and species present in either the northern or central Andes or present in both, and finally individual countries. This Excel spreadsheet is available on the Andean web page "Overview of Region and Countries" under tropical Andes: <<http://mobot.mobot.org/W3T/Search/andes/overviewtropicalandes.htm>>.

TAXONOMIC DIVERSITY

Moss diversity for the tropical Andes is estimated at 1376 species, 327 genera, and 69 families (Appendix 1). The number of species is substantially lower than the 2058 species estimated previously (Churchill et al., 1995), whose figures included a small fraction of the species present in the lowlands. Even the projected estimate of 1500 to 1700 species (Churchill et al., 1995), considered a more realistic figure, is not substantiated. The number of specific and infraspecific moss synonyms presently recorded for the tropical Andes is 929 (Appendix 1), many of which were recognized in the past three decades.

The 10 most speciose families (Table 1) account for 861 species, containing a significant portion (66%) of



Figure 1. Map of the tropical Andes with the numbers of species for each of the countries.

the total moss diversity for the tropical Andes. This is nearly identical to that estimated by Churchill et al. (1995). Differences include in part the recognition of the Macromitriaceae (segregated from Orthotrichaceae, cf. Churchill & Linares C., 1995) and the significant increase in newly described species of

Sphagnum. Other factors include the reduction of previously recognized names due to new synonymy for the Grimmiaceae, or names excluded in this study as status unknown, for example *Mittenothamnium* Henn., which contains an inordinate number of names, many likely referable to *M. reptans* (Hedw.) Cardot.

Table 1. The 10 most diverse moss families and genera for the tropical Andes.

Family	No. of species	Genus	No. of species
Pottiaceae	172	<i>Sphagnum</i> (Sphagnaceae)	61
Bryaceae	130	<i>Campylopus</i> (Dicranaceae)	49
Dicranaceae	129	<i>Fissidens</i> (Fissidentaceae)	46
Pilotrichaceae	109	<i>Bryum</i> (Bryaceae)	44
Bartramiaceae	64	<i>Zygodon</i> (Orthotrichaceae)	33
Sphagnaceae	61	<i>Macromitrium</i> (Macromitaceae)	30
Sematophyllaceae	52	<i>Didymodon</i> (Pottiaceae)	26
Orthotrichaceae	51	<i>Syntrichia</i> (Pottiaceae)	26
Macromitriaceae	47	<i>Lepidopilum</i> (Pilotrichaceae)	25
Fissidentaceae	46	<i>Schizymenium</i> * (Bryaceae)	24

* Coequal with *Sematophyllum* (Sematophyllaceae).

The 10 most diverse moss genera in the tropical Andes containing 20 or more species are listed in Table 1. Just these 10 of the 327 genera account for 26% of the total species recorded. Eight of these 10 genera have been revised or under current study so that these numbers seem to be a reliable estimate. This may be the case with *Zygodon* Hook. & Taylor (see families discussed below) but is less certain for *Sematophyllum* Mitt., which lacks modern revisionary studies. At the other end of the generic spectrum, 159 or 49% of the genera recorded for the tropical Andes are represented by a single species; 55 of the 159 represent monospecific genera.

ENDEMISM

A taxon is considered endemic if it is only known from within the geographical range of the tropical Andes; that range may be restricted to a single locality or span the entire length of the tropical Andes. The number of endemic species estimated for the tropical Andes is 428 species distributed among 137 genera and 38 families (Appendix 1). The number of endemic species is 31% of the total recorded for the tropical Andes. Twenty genera are endemic to the tropical Andes (Table 2). All are monospecific with the exception of *Sciuroleskea* Hampe ex Broth., with two

Table 2. Endemic genera of the tropical Andes. Provided for each genus are the family, associated Andean vegetation, elevational range, and distributional range by country.

Genus	Family	Vegetation	Elevation (m)	Country
<i>Aligrimmia</i>	Grimmiaceae	puna	2250–2700	Peru
<i>Allioniellopsis</i>	Sematophyllaceae	low montane forest	750–1400	Ecuador, Peru
<i>Callicostellopsis</i>	Pilotrichaceae	páramo/puna	3480–3620	Venezuela, Bolivia
<i>Flabellidium</i>	Brachytheciaceae	low montane forest	ca. 1400	Bolivia
<i>Gradsteinia</i>	Amblystegiaceae	páramo	ca. 3650	Colombia
<i>Koponenia</i>	Amblystegiaceae	puna	ca. 4600	Bolivia
<i>Leskeadelphus</i>	Leskeaceae	high montane, páramo/puna	1300–4000	Colombia, Bolivia
<i>Leptodontiella</i>	Pottiaceae	open montane	600–4235	Peru
<i>Lindigia</i>	Brachytheciaceae	montane forest	1800–3400	all
<i>Mandoniella</i>	Brachytheciaceae	montane forest	1700–3350	Bolivia
<i>Polymerodon</i>	Dicranaceae	puna	3600–4620	Bolivia
<i>Porotrichopsis</i>	Neckeraceae	mid to high montane forest	2000–3800	Colombia, Bolivia
<i>Pseudohyophila</i>	Dicranaceae	puna	ca. 3820	Peru
<i>Schroeterella</i>	Sematophyllaceae	montane forest	ca. 2200	Bolivia
<i>Sciuroleskea</i>	Stereophyllaceae	montane forest	1300–3160	Ecuador, Peru
<i>Stenocarpidiopsis</i>	Brachytheciaceae	montane forest	1400–2150	Ecuador, Peru
<i>Stenodesmus</i>	Pilotrichaceae	montane forest	700–925	Colombia, Ecuador
<i>Streptotrichum</i>	Pottiaceae	high montane forest	3140–3400	Bolivia
<i>Timotimius</i>	Sematophyllaceae	montane forest	ca. 2350	Ecuador
<i>Trachyodontium</i>	Pottiaceae	montane forest	ca. 2650	Ecuador

Table 3. Families and genera with 10 or more endemic species for the tropical Andes.

Family	No. of species	Genus (family)	No. of species
Pottiaceae	60	<i>Sphagnum</i> (Sphagnaceae)	35
Pilotrichaceae	49	<i>Zygodon</i> (Orthotrichaceae)	23
Bryaceae	46	<i>Lepidopilum</i> (Pilotrichaceae)	15
Dicranaceae	37	<i>Schizymerium</i> (Bryaceae)	15
Sphagnaceae	35	<i>Sematophyllum</i> (Sematophyllaceae)	14
Orthotrichaceae	33	<i>Campylopus</i> (Dicranaceae)	12
Bartramiaceae	23	<i>Macromitrium</i> (Macromitaceae)	11
Sematophyllaceae	21	<i>Daltonia</i> (Daltoniaceae)	11
Daltoniaceae	18	<i>Orthotrichum</i> (Orthotrichaceae)	11
Brachytheciaceae	13	<i>Cyclodictyon</i> (Pilotrichaceae)	10
Macromitriaceae	11	<i>Didymodon</i> (Pottiaceae)	10
Ditrichaceae	10	<i>Syntrichia</i> (Pottiaceae)	10
Polytrichaceae	10		

species. There are a few genera that could be classified as subendemic, i.e., isolated outliers from the main Andean range. For example, the monospecific genus *Gertrudiella* Broth. (Pottiaceae) is primarily found in dry inter-Andean valleys from southern Peru to northwestern Argentina, but has been recorded from a single locality in the Bolivian Chaco forest near the sub-Andean range and also from northernmost Chile.

There are 13 families that include 10 or more endemic species (Table 3). Significantly, just these 13 families of the total 69 Andean families account for 87% of species endemism. Within these, 12 genera contain 10 or more endemic species, and these 12 encompass 42% (177) of the 428 total Andean endemics.

NOTEWORTHY MOSS FAMILIES OF THE TROPICAL ANDES

Twenty of 69 families of the tropical Andes (Appendix 1) that are considered significant for reasons of diversity, endemism, ecology, and distribution are discussed below.

AMBLYSTEGIACEAE

The majority of the genera and species are found in the high montane to páramo and humid puna. Ecologically, a number of the genera are a major component and play a significant role, second only to Sphagnaceae, in the Andean aquatic systems (i.e., lakes and ponds, streams and rivers, bogs and marshes). Aquatic and semi-aquatic genera include *Cratoneuron* (Sull.) Spruce, *Drepanocladus* (Müll. Hal.) G. Roth, *Pseudocalliergon* (Limpr.) Loeske, *Scorpidium* (Schimp.) Limpr., *Straminergon* Hedenäs, and *Warnstorfia* Loeske. Endemic genera, all monospecific and only known from the type collection, include *Gradsteinia* Ochyra, found on rocks in streams of the

Colombian Eastern Cordillera, and *Koponenia* Ochyra, found on rocks in springs or streams of the Real Cordillera of Bolivia (Table 2). The Amblystegiaceae were recently revised by Hedenäs (2003) for the Neotropics.

ANDREAEACEAE

Andreaeaceae is almost exclusively found in páramo and puna on rocks. A few species are semi-aquatic or aquatic, e.g., *Acroschisma wilsonii* (Hook. f. & Wilson) A. Jaeger, *Andreaea nitida* Hook. f. & Wilson, and *A. subulata* Harv. A major portion of the 20 ecostate *Andreaea* Hedw. species previously described from the Andes have not been reevaluated; revisionary studies may add five to 10 species based on observed morphological variation of selected *Andreaea* types and general collections examined by the author, of which some will likely be endemic.

BARTRAMIACEAE

Bartramiaceae is the fifth largest family for the Andes, with 64 species, 23 of which are endemic. Nearly all of the genera of the Bartramiaceae are terrestrial, common in the open montane to páramo and puna. *Leiomela* (Mitt.) Broth. is the exception, mostly found in montane forest as an epiphyte. *Breutelia* (Bruch & Schimp.) Schimp. is a common component of bogs, and *Philonotis* Brid. is common along streams and seeps. Revisionary studies are required for *Philonotis*, where the status is unknown for 21 species and the nonclasping, leaf-based species of *Breutelia*.

BRACHYTHECIACEAE

The Brachytheciaceae is the tenth largest family, with most genera associated with the montane forest.

The family, as now circumscribed, includes five genera previously associated with the Meteoriacaeae: *Aerolindigia* M. Menzel, *Lindigia* Hampe, *Meteoridium* (Müll. Hal.) Manuel, *Squamidium* (Müll. Hal.) Broth., and *Zelometeorium* Manuel (Ignatov & Huttunen, 2002). All five genera generally occur as epiphytes, often common and abundant, in montane forest throughout the Andes. There are four Andean endemic monospecific genera (Table 2), all occurring as epiphytes: *Flabellidium* Herzog, *Mandoniella* Herzog, *Lindigia*, and *Stenocarpidiopsis* M. Fleisch. ex Broth. The only exclusively aquatic genus is *Platyhypnidium* M. Fleisch., typically occurring on rocks in streams. The outstanding unrevised taxa of the Brachytheciaceae involve the generic complex *Rhynchostegium* Bruch & Schimp. and *Eurhynchium* Bruch & Schimp.; both have rather numerous names (status for 19 unknown) but probably few species, and likely even fewer or no endemics.

BRYACEAE

Bryaceae is the second largest Andean family, with 130 species and 46 endemics (Appendix 1). The majority of genera and species are terrestrial and found in the open montane to páramo and puna. Important genera of the high montane and páramo/puna regions are *Anomobryum* Schimp., *Pohlia* Hedw., and most notably, *Schizymerium* Harv. *Acidodontium* Schwägr., with nine of 11 species endemic, is exclusively epiphytic, often occurring as twig epiphytes, as are about half of the species of *Brachymerium* Schwägr. Genera with at least some forest species include *Bryum* Hedw., *Epipterygium* Lindb., *Orthodontium* Schwägr., and *Rhodobryum* (Schimp.) Limpr. The treatments by Ochi (1980, 1981) for *Acidodontium*, *Anomobryum*, *Brachymerium*, *Bryum*, and *Rhodobryum* provided a very important foundation for these diverse genera; however, all would benefit by at least a regional revision. Revisionary studies are required for the taxa associated with *Mielichhoferia* Nees & Hornsch. and *Schizymerium*.

DALTONIACEAE

This family is restricted exclusively to the montane forest of the tropical Andes. The most notable genus of this family is *Daltonia* Hook. & Taylor, with 11 of the 17 species endemic to the tropical Andes, which also appears to be the center of diversity for the genus. Species are small and inconspicuous, characteristically one or a few individuals are found on twigs of shrubs (e.g., *Baccharis* L.) and trees and are often present on nodes of bamboo (*Chusquea* Kunth). Only

Calyptrochaeta Desv. and *Leskeodon* Broth. remain to be revised.

DICRANACEAE

Rich in genera, the Dicranaceae is the third largest family for the tropical Andes, with 129 species distributed among 28 genera. Many of the species are terrestrial, found on soil, humus, rocks, and logs. However, a significant portion or all of the following genera are epiphytic: *Campylopus*, *Chorisodontium* (Mitt.) Broth., *Eucamptodontopsis* Broth., *Holomitrium* Brid., *Leucoloma* Brid., *Schliephackea* Müll. Hal., and *Symblepharis* Mont. *Campylopus* is the second largest genus in the tropical Andes, with 49 species, amply diversified in most habitats (except aquatic). *Schliephackea*, with two species in the northern Andes, is the only genus of this family with a pendent growth form in the New World. Critical revisionary studies are needed for the generic complex that includes *Dicranella* (Müll. Hal.) Schimp. and *Microdus* Schimp. ex Besch. *Pseudohyophila* Hilp. is the only endemic genus for the family (Table 2); although it is placed in the Dicranaceae, its systematic position is unclear.

DITRICHACEAE

Astomiopsis Müll. Hal., *Bryomanginia* Thér., *Pleuridium* Rabenh., and *Tristichium* Müll. Hal. are very small-statured, cleistocarpic or gymnostomous genera. Six of the nine species of these genera are endemic, all confined, for the most part, to the páramo and puna. *Chrysoblastella* R. S. Williams and *Distichium* Bruch & Schimp., both with a single species, are also restricted to the páramo and puna. *Ditrichum* Hampe may have a few additional species and some possibly endemic, but revisionary studies are needed.

FISSIDENTACEAE

The majority of the *Fissidens* Hedw. species belonging to this monogeneric family are small and inconspicuous. Species occur on nearly all substrates. Many of the species are widespread in the Neotropics, although 62% of the 93 recognized species are endemic to the region (Pursell, 2007). It is rather surprising that of the 46 species present in the Andes, only four are endemic. *Fissidens* is the third largest genus for the tropical Andes (Table 1), with about 50% of the recognized Neotropical species occurring within the Andean range.

GRIMMIACEAE

The majority of genera and species are found on rocks in the high montane to páramo and puna.

Grimmia, as with *Andreaea*, is a typical component of the páramo and puna, with 15 species. Eight of the 40 species of this family are endemic to the Andes. Endemic monospecific genera restricted to the central Andes are *Aligrimmia* R. S. Williams and *Coscindontella* R. S. Williams. The genus requiring revisionary study is *Schistidium* Bruch & Schimp., which may have as many as 15 species, and some will certainly be endemic to the Andes; the status of 12 species is unknown.

HYPNACEAE

The Hypnaceae contains 17 genera, 33 species, and only five endemic species. In terms of distribution, many of the genera and species are widespread and common throughout the Andes. Ecologically, several genera are very abundant and conspicuous in montane forests, often occurring in extensive mats, e.g., *Ctenidium* (Schimp.) Mitt., *Hypnum* Hedw., and *Mittenothamnium*. The most problematic genus requiring revisionary study is *Mittenothamnium*, for which numerous names have been proposed (28 names considered in this study as status unknown); it is likely that fewer than 10 species will be recognized.

MACROMITRIACEAE

Macromitrium Brid. is one of the principal generic elements of the Andean montane forest. The center of species diversity for this genus will likely prove to be the tropical Andes. Most species are epiphytic and commonly present in the canopy of high montane forest. More species will be recognized, based on examined types and general collections from the tropical Andes, and may total up to 50, with as many as half endemic. *Schlotheimia* Brid. requires revisionary studies; 14 species have been reported or described from the central Andes, particularly in Bolivia, but fewer than seven will likely be recognized.

NECKERACEAE

Despite having relatively few species (26) and only four endemics, the Neckeraceae is a significant component of montane forest throughout the Andes. This is particularly true of the mostly epiphytic genera *Neckera* Hedw., *Porotrichodendron* M. Fleisch., and *Porotrichum* (Brid.) Hampe, which can form extensive dendroid tufts on trunks and branches of trees. *Porotrichopsis* Broth. & Herzog, with one species, is the only endemic genus in the Neckeraceae for the Andes (Table 2). *Porotrichopsis flacca* Herzog is

rather small and inconspicuous, resembling a depauperate species of *Porotrichum*.

ORTHOTRICHACEAE

Represented by two diverse genera, *Orthotrichum* Hedw. and *Zygodon*, the majority of the species are epiphytic and concentrated in the transitional high montane forest and páramo-puna zone. Both genera contain a significant number of endemic species: *Orthotrichum* with 11 of 18 species and *Zygodon* with 22 of 33 species. *Zygodon*, monographed by Malta (1926), requires a reevaluation of the species, but will likely remain one of the most diverse genera for the tropical Andes as can be presumed from the revision of the southern South American taxa by Calabrese (2006). *Orthotrichum* was revised by Lewinsky (1984, 1987).

PILOTRICHACEAE

The family is the fourth largest for the tropical Andes, with 19 genera and 109 species (Appendix 1). The Pilotrichaceae is the second most diverse family in the number of endemics, with 49 species (Table 3). The center of diversification of the Pilotrichaceae is in the northern Andes and, to a great extent, in Central America. Many of the genera and species are associated with montane cloud forest. The combination of diversity and endemism marks this family as the single most important in the cloud forest ecosystem. A number of genera are typically found over leaf litter, humus, and logs; epiphytic genera include *Actinodontium* Schwägr., *Lepidopilum* (Brid.) Brid., *Pilotrichum* P. Beauv., and *Stenodesmus* (Mitt.) A. Jaeger. *Crossomitrium* Müll. Hal. is one of very few moss genera in which several species are commonly epiphyllous. Genera requiring revisionary studies include *Callicostella* (Müll. Hal.) Mitt., *Cyclodictyon* Mitt., and *Trachyxiphium* W. R. Buck.

POLYTRICHACEAE

The family is exclusively terrestrial. Nearly all of the species in the Andes are found in open mid to high montane, páramo, and puna. The species of this family play a significant role in the colonization of disturbed montane slopes and are among the first plants to stabilize recent landslides and newly cut road banks. Very few species are associated with montane forest; genera include *Atrichum* P. Beauv., *Steeerobryon* G. L. Sm., and a few species of *Pogonatum* P. Beauv. Within the Neotropics, the tropical Andes contain the highest diversity of genera (9) and species (23) for this family. The genus *Polytrichadelphus* (Müll. Hal.) Mitt.

has its center of diversity and names in the tropical Andes; it is the only genus of the Polytrichaceae that still requires a careful revisionary study.

POTTIACEAE

The Pottiaceae is the single most diverse family for the tropical Andes in terms of genera, species, and endemics (Appendix 1, Tables 1, 3). The majority of the genera are common in the wet and dry páramo and puna, and in the dry inter-Andean valleys occurring on soil and rocks. In the montane region, a number of genera are common in open forested areas and deforested sites. Genera with some or all species found as montane epiphytes include *Streptopogon* (Taylor) Wilson ex Mitt., *Leptodontium* (Müll. Hal.) Hampe ex Lindb. p.p., and *Syntrichia* Brid. p.p.; three other genera represent monospecific endemics, each known from a particular country: *Leptodontiella* R. H. Zander & E. H. Hegew. (Peru), *Streptotrichum* Herzog (Bolivia), and *Trachyodontium* Steere (Ecuador). The entire family is now being revised by bryologists from Universidad de Murcia (Cano et al., 2008), with treatments completed or near completion for *Didymodon* Hedw., *Hennediella* Paris (Cano, 2008), *Syntrichia*, and *Tortula* Hedw. (Cano & Gallego, 2008).

SEMATOPHYLLACEAE

Represented by 14 genera, the Sematophyllaceae is the seventh largest family for the tropical Andes, with 52 species (Appendix 1). The most diverse genus, *Sematophyllum*, is found throughout the Andean montane region, occurring as epiphytes in forested areas and equally associated with streams and rivers on rocks. Among the genera in critical need of revisionary study are both *Sematophyllum* and *Trichosteleum* Mitt. The former is likely to have additional recognized species and endemics; the status of some 17 species is unknown. Three monospecific genera, all epiphytic, are endemic to the tropical Andes (Table 2): *Allioniellopsis* Ochyra, known only from three localities in Ecuador and Peru; *Schroeterella* Herzog, from a single locality in Bolivia; and *Timotimus* W. R. Buck, also from a single locality in Ecuador.

SORAPILLACEAE

This monogeneric family is of interest for its rather peculiar gametophytic morphology and distribution. *Sorapilla* Spruce & Mitt. is represented by two species, *S. sprucei* Mitt. and *S. papuana* Broth. & Geh., the former from the Neotropics and the latter from Australasia. The genus exhibits a leaf structure

similar to that of *Fissidens*. The phylogenetic relationship of this taxon is thought to be with the Neckeraceae (Allen, 1981). *Sorapilla sprucei* is only known from a collection made by Richard Spruce in 1857 from the lower montane forest of Abitagua at about 1850 m.

SPHAGNACEAE

Sphagnum is the single most important genus of the aquatic ecosystems of the Andes. It is a typical component of bogs, lake, and stream margins in the páramo and humid puna, but it is also found associated with seeps and springs in montane areas. Nearly all of the 35 of 61 species considered endemic to the Andes were described by Howard Crum between 1985 and 1997. It seems likely that a reevaluation of these species will result in some being reduced to synonymy, in some cases entailing emended species concepts. Others are very likely to be considered distinct and endemic. Given the very important role of this genus in the Andean ecosystem, a revision is imperative.

REGIONAL AND COUNTRY DIVERSITY

The tropical Andes may be divided geographically into two areas, the northern and central Andes. For pragmatic purposes, in this analysis the northern Andes are defined as including the cordillera systems of Venezuela, Colombia, and Ecuador, and the central Andes are defined as including the cordillera systems of Peru, Bolivia, and the northwestern portion of Argentina. The generally accepted division between the two regions is the Huancabamba Depression in the extreme north of Peru (Duellman, 1979), but too little collection data exist for this area of Peru. The number of mosses common to both the northern and central Andes is 816 (59%). More than half of these species are common and widespread throughout the Andes, as exemplified by *Plagiomnium rhynchophorum* (Harv.) T. J. Kop. (for this and other species discussed below, view maps in Tropicos); other species appear as disjuncts such as the endemic *Porotrichopsis flacca*, but this may simply be a collecting artifact. The northern Andes contain 321 unique species (23% of total), thus the total for this region is 1137 species. At least a number of the species are more restricted in their distribution, as exemplified by *Polytrichadelphus ciliatus* (Hook. & Wilson) Mitt. The central Andes contain 241 unique species (18%), a total of 1057 species. Again, some of the species are narrowly distributed, such as the endemic *Streptotrichum ramicola* Herzog, which may be more widespread, extending even into Peru, but the substrate this moss

Table 4. Summary of moss diversity for the five individual countries and three provinces (Jujuy, Salta, and Tucumán) in northwestern Argentina.

Country	Total in country	Total in Andean portion	% of total Andes
Venezuela	734	681	53%
Colombia	915	883	67%
Ecuador	807	796	59%
Peru	775	761	56%
Bolivia	901	884	66%
Northwestern Argentina	125	122	9%

occupies, nodes of bamboo, is rarely sampled. A comparison of two families, Pilotrichaceae and Pottiaceae, serves to emphasize the difference between the two regions based on vegetation and ecology. The Pilotrichaceae are most diverse in montane cloud forest, many as epiphytes, while the Pottiaceae are most common in open montane, páramo, and puna regions, nearly all terrestrial. This is reflected in the differences between Colombia and Bolivia. The Pilotrichaceae in Colombia has 78 species, and Bolivia, 47. The Pottiaceae in Bolivia has 118 species, and in Colombia, 69. This likely reflects the more complex and extensive cordillera system of montane forest in Colombia as compared with a much smaller and less complex cordillera in Bolivia. Conversely, the Bolivian puna (humid, semi-humid, desert) and dry inter-Andean valleys are extensive compared with Colombia, which has distinctly isolated páramos and dry inter-Andean valleys.

The number of species recorded for each country varies from 734 to 915, excluding northwestern Argentina (Table 4). Colombia is the most diverse, with 915 species, but nearly equal is Bolivia, with 901. Ecuador, for its small size, is notably diverse, with 807 species. Both Venezuela and Peru have fewer species. The number of species recorded for Venezuela (734) may be due to the smaller area occupied by the Andes, or more likely, further inventory will discover additional species. There is little doubt that Peru is undercollected, with only 775 species, and will be equal to or greater than the number of species recorded for Bolivia or Colombia. The Andean portion of each country (Table 4) shows that there are only a few species from the lowlands that are not present in the Andes. Venezuela has more non-Andean species than any of the countries; this may be due to the Caribbean coastal regions and the tepui regions.

Table 5. The distribution of 428 endemic species for the tropical Andes, northern and central Andes, and individual countries including northwestern Argentina (endemics shared between the two regions is 144 species).

Area	Country	No. of species	% of total
Northern Andes		51	12%
	Venezuela	13	3%
	Colombia	49	11%
Central Andes	Ecuador	42	10%
		39	9%
	Peru	31	7%
	Bolivia	56	13%
	Northwestern Argentina	3	>1%

REGIONAL AND COUNTRY ENDEMISM

Endemism for the regions and countries differs slightly from the overall results for the countries, again excluding northwestern Argentina (Table 5). The number of shared endemics between the northern and central Andes is 144 species. There are slightly more endemics recorded for the northern Andes (155) than for the central Andes (129). Among the countries, the difference is with Bolivia, which contains more endemics (56) than Colombia (49), followed by Ecuador (42), Peru (31), and Venezuela (13).

TRENDS IN MOSS DIVERSITY FOR THE TROPICAL ANDES

PATTERNS OF DIVERSITY

The patterns of diversity can be viewed at different levels. The supposition for the observed pattern of moss diversity in the tropical Andes is that alpha diversity may be comparable to other forested areas (e.g., lowland forest) but beta diversity, species turnover, is significantly higher, accounting for species differences within and between elevational gradients and ecoregions present in the tropical Andes (Churchill et al., 1995). The result is that gamma diversity is exceptionally high for the tropical Andes. This scenario has not been tested. This explanation appears to be supported by the observed differences in moss diversity (gamma) seen in data comparing the Amazon Basin to the tropical Andes. The area of the Amazon Basin, slightly less than the size of the contiguous United States, is nearly 4.5 times larger than that of the tropical Andes. The mosses of the Amazon Basin are estimated at 311 species (Churchill, 1998), compared to 1376 species for the tropical Andes; thus, the much smaller area of the Andes is 4.4 times more diverse than the Amazon.

LATITUDINAL GRADIENT

The cordillera systems of Central America and the Andes are the only reason mosses do not serve as a classic contrary example to the latitudinal gradient norm that diversity increases toward the equator (Churchill, 1991; Churchill et al., 1995; Shaw et al., 2005). Latitudinal gradient is a rather loose, broad generalization with various "classic" examples (e.g., birds, trees), but in some cases this appears to be avoiding other patterns of distributional diversity. The contrast in moss diversity between the two largest geographical regions of tropical South America, the Amazon Basin and the tropical Andes, could not be clearer (see discussion above). In the absence of elevated topography (i.e., the cordillera systems of Central and South America), moss diversity in the Neotropics would be the same as in the Amazon Basin, i.e., ca. 300 species (or slightly greater). It is oversimplified but accurate to note that bryophytes generally reach their greatest diversity in environments of overall cool temperatures and continual precipitation in the form of rain or mist fogs (e.g., in the montane forest) or pronounced seasonality of precipitation (e.g., in the páramo or puna)—essentially equivalent to the environment of temperate and boreal forest, and tundra of the Northern Hemisphere.

ELEVATION

One obvious trend of major interest for the tropical Andes is elevational gradient. Mosses, as well as liverworts, reach their highest diversity levels in the montane regions of the tropical Andes. This narrow band of vegetation, including both forested and open montane areas, contains an estimated 60% or more of the mosses of the tropical Andes. An analysis of elevational distribution of Colombian mosses demonstrated a gradual increase in species diversity maximizing at 2500–3000 m, with the next highest level of species diversity at 2000–2500 m, and the third at a higher elevation, 3500–4000 m. The number of unique species found within an elevational range showed a similar pattern in Colombia; for example, the 2500–3000 m range also contained the greatest number of species not present at other elevation ranges. In a study of ferns and bryophytes from various tropical Andean localities, Kessler (2000) noted that elevational boundaries were well correlated with major ecological changes, essentially two such zones. One major zone could be interpreted as the transition between lowland forest and low montane forest (premontane). The second significant change occurred at the highest forest boundary, the transitional high montane forest with páramo-puna.

Between these low and high zones, species composition showed little change.

ECOREGION DIVERSITY

The diversity and composition of mosses present in the various ecoregions (essentially equal to vegetation types) have not been well documented. Although it may be intuitively apparent based on casual observation that certain ecoregions are more diverse than others, for example that montane forests are more species-rich than dry inter-Andean valleys, there is a need to quantify such patterns. Bolivia, for which there are preliminary data (Churchill, Sanjines & Aldana, in prep.), is presented as an example. There are seven major ecoregions recognized in Bolivia (Fig. 2). Bolivia can be divided into two general areas: the highlands (Andes), occupying ca. 40% of the land surface, and the much larger lowlands (Oriente), occupying 60%. In the highlands, the Yungas montane forest occupies only 5% of the country's land surface but is disproportionately the most diverse ecoregion, containing 61% of the 901 mosses recorded for Bolivia. The puna is the second most diverse ecoregion with 30%, followed by the Tucumán-Bolivian montane forest with 25%, and the dry inter-Andean valleys with 7%. In the lowlands, diversity corresponds to a precipitation gradient of high in the north to low in the south; the Amazon forest, occupying 34% of the Bolivian land surface, is the most diverse region in the lowlands with 11% of the total number recorded for the country, followed by the Chiquitano forest, with 10%, and Chaco, with an estimated 3%. The diversity of mosses for these ecoregions may be similar to other tropical Andean countries; only the Chiquitano is unique to Bolivia, and Chaco is also present in northwestern Argentina. This also serves to demonstrate that the tropical Andes is more than just montane forest, with significant contributions from the dry inter-Andean valleys, páramo, and puna that add to the rich moss diversity of the region.

TRENDS IN ACTIVITIES

There are some notable trends, both positive and negative, that have an impact on our developing knowledge of the tropical Andean mosses. The most encouraging development has been the progress of bryology in the Andean countries. Much of this has occurred in the past decade. There are now individuals in all the tropical Andean countries involved at some level of bryological research. These individuals have contributed significantly in developing and expanding research collections that were

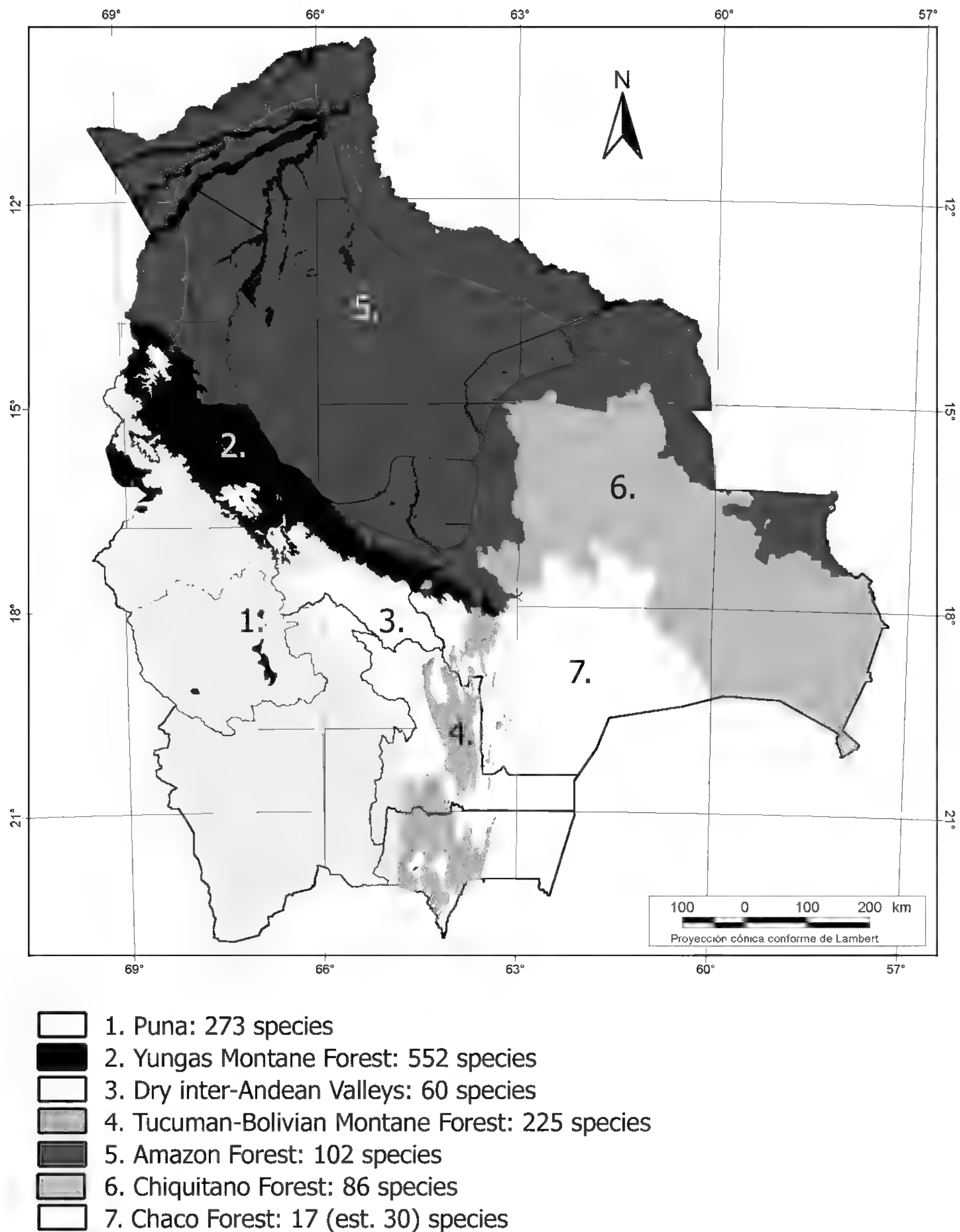

Figure 2. Moss diversity among the seven ecoregions of Bolivia.

heretofore in most cases meager or nonexistent. Colombia provides a good example of these trends as reflected in the number of publications. In three 6-year intervals, the number of bryological publications by Colombians has increased significantly: 1990–1995 (2), 1996–2000 (9), 2001–2005 (22). The other development has been a web page devoted to the mosses of the tropical Andes (Churchill & collaborators, 2008). This web site provides the following main sections: Overview of Region and Countries, Key to Andean Moss Families, Family Treatments and

Checklists (English), Spanish Family Treatments and Checklists, Index of Synonyms and Other Names, Bibliography and Literature Cited, Author List, Collector List, and Bryophytes of Bolivia. Both family treatments are linked to the Tropicos database (<<http://www.tropicos.org/>>, Missouri Botanical Garden).

The negative trend is the significant downturn of revisionary studies. Our understanding of Neotropical mosses has increased significantly in the past 30 years. A notable number of bryologists from North

America, Europe, and Japan focused their research in various regions of the Neotropics, both in terms of fieldwork and revisionary studies. This trend, in the form of publications, could be said to have increased almost exponentially beginning in the late 1960s and early 1970s, peaked in the 1980s, and by the late 1990s began a sharp decline. This trend was a result of economic growth of the 1960s and the concurrent expansion in universities and faculty. As new bryologists gained expertise, the number of publications increased in the 1980s and most of the 1990s until an economic downturn, university cutbacks, and faculty attrition through retirement or death resulted in a noticeable decrease in publications. The commencement of biodiversity studies in the 1980s, which can be coupled with the publication of *Biodiversity* (Wilson & Peter, 1988), was in fact the beginning of a decline in taxonomic expertise. What was accomplished in ca. 20 years, however, was almost certainly a 10-fold increase of new collections in the Neotropics, as well as equally important revisionary studies that advanced our understanding of 35%–45% of the taxa, providing a better understanding of diversity.

CONCLUSION

Given the state of knowledge of the tropical Andean mosses, estimates of the number of taxa, particularly species, are and will continue to be in a state of flux. There are species to be newly described, even more to be relegated to synonymy, and new species records for the region and the individual countries (particularly for Peru). Over the next few decades, there will be a significant level of uncertainty with regard to moss diversity and composition for the tropical Andes. The estimates presented at any one time for moss diversity are relative. And I cannot refrain from saying (after more than 20 years studying the Andean mosses) that uncertainty and relativity apply wonderfully well to our attempts to delineate species and vegetation.

A priority for the tropical Andes must be to provide a better resolution of species through revisionary studies and floras to promote an understanding of moss diversity. This would allow a greater understanding of distribution and ecology and provide a better means of assessing rarity and conservation. There is urgency to this priority given the major role mosses and hepatics play in the Andean ecosystem. Degradation of the Andean landscape has had a major impact on the ecosystem. The predicted loss of glaciers throughout the Andes in the next few decades (Bradley et al., 2006; Vergara et al., 2007) will severely alter the humid puna and páramo ecosystems. This can only exacerbate the situation faced by the

major Andean cities (with ever-increasing population growth) that depend on water from these ecosystems. The continuing loss of glacial water will likely impact the montane forest, which is currently the second most important source of water. Any attempt to further alter these forests can only lead to a greater loss of water and soil, to say nothing of the plant and animal diversity contained in this narrow band of forest that spans the length of the tropical Andes. To ensure the continuing function of the montane forest, the area must be recognized as an endangered ecosystem and protected, not only for the water it provides but also for the rich diversity it contains, including mosses.

Literature Cited

- Allen, B. H. 1981. A reevaluation of the Sorapillaceae. *Bryologist* 84: 335–338.
- Bradley, R. S., M. Vuille, H. F. Diaz & W. Vergara. 2006. Threats to water supplies in the tropical Andes. *Science* 312: 1755–1756.
- Calabrese, G. M. 2006. A taxonomic revision of *Zygodon* (Orthotrichaceae) in southern South America. *Bryologist* 109: 453–509.
- Cano, M. J. 2008. Taxonomic revision of *Hennediella* Paris (Pottiaceae, Bryophyta). *Bryophyt. Biblioth.* 64: 1–142.
- & M. T. Gallego. 2008. The genus *Tortula* (Pottiaceae, Bryophyta) in South America. *Bot. J. Linn. Soc.* 156: 173–220.
- , ———, J. Guerra & J. A. Jiménez. 2008. Pottiaceae. Integrated Taxonomic Information System. Universidad de Murcia. <<http://pottiaceae.com>>, accessed 30 April 2009.
- Churchill, S. P. 1989. *Bryologia Novo Granatensis*. Estudios de los musgos de Colombia IV. Catálogo nuevo de los musgos de Colombia. *Trop. Bryol.* 1: 95–132.
- . 1991. The floristic composition and elevational distribution of Colombian mosses. *Bryologist* 94: 157–167.
- . 1994. The mosses of Amazonian Ecuador. *AAU Rep.* 35: 1–211.
- . 1998. Catalog of Amazonian mosses. *J. Hattori Bot. Lab.* 85: 195–242.
- & D. Griffin III. 1999. Mosses. Pp. 53–64 in J. L. Luteyn (editor), *Páramos: Their Phytodiversity, Geographical Distribution and Botanical Literature*. *Mem. New York Bot. Gard.* 84.
- & E. L. Linares C. 1995. *Prodromus Bryologiae Novo Granatensis*. *Bibliot. Jose Geronimo Triana* 12: 1–924.
- , D. Griffin III & M. Lewis. 1995. Moss diversity of the tropical Andes. Pp. 335–346 in S. P. Churchill, H. Balslev, E. Forero & J. L. Luteyn (editors), *Biodiversity and Conservation of Neotropical Montane Forests*. New York Botanical Garden, Bronx.
- , ——— & J. Muñoz. 2000. A checklist of the mosses of the tropical Andean countries. *Ruizia* 17: 1–203.
- & collaborators. 2008. Mosses of the Tropical Andes. <<http://mobot.mobot.org/W3T/Search/andes/andesintro.htm>>, accessed 30 April 2009.
- Crosby, M. R., R. E. Magill, B. Allen & S. He. 2000. A Checklist of the Mosses. Missouri Botanical Garden, St. Louis.
- Delgadillo, M. C. 1994. Endemism in the neotropical moss flora. *Biotropica* 26: 12–16.

- Duellman, W. E. 1979. The herpetofauna of the Andes: Patterns of distribution, origin, differentiation, and present communities. *Monogr. Mus. Nat. Hist. Univ. Kansas* 7: 371–459.
- Florschütz-de Waard, J. & P. A. Florschütz. 1979. Estudios sobre Criptógamas Colombianas III. Lista comentada de los Musgos de Colombia. *Bryologist* 82: 215–259.
- Frahm, J.-P. 1991. Dicranaceae: Campylopodioideae, Paraleucobryoideae. *Fl. Neotrop.* 54: 1–238.
- . 2003. Manual of tropical bryology. *Trop. Bryol.* 23: 1–196.
- Fransén, S. 1995. A taxonomic revision of Neotropical *Bartramia* section *Vaginella* C. Müll. *Lindbergia* 20: 147–179.
- Gentry, A. 1982. Neotropical floristic diversity: Phyto-geographical connections between Central and South America, Pleistocene climatic fluctuations, or an accident of the Andean orogeny? *Ann. Missouri Bot. Gard.* 69: 557–593.
- Gradstein, S. R., S. P. Churchill & N. Salazar Allen. 2001. A guide to the bryophytes of tropical America. *Mem. New York Bot. Gard.* 86: 1–571.
- , R. I. Meneses Q. & B. A. Arabe. 2003. Catalogue of the Hepaticae and Anthocerotae of Bolivia. *J. Hattori Bot. Lab.* 93: 1–67.
- Hedenäs, L. 2003. Amblystegiaceae (Musci). *Fl. Neotrop.* 89: 1–108.
- Hedwig, J. 1801. *Species Muscorum Frondosorum*. J. A. Barth, Leipzig.
- Hermann, F. J. 1976. Recopilación de los musgos de Bolivia. *Bryologist* 79: 125–171.
- Herzog, T. 1916. Die Bryophyten meiner zweiten Reise durch Bolivia. *Biblioth. Bot.* 87: 1–347.
- Hooker, W. J. 1818–1820. *Musci Exotici*. Longman et al., London.
- Ignatov, M. S. & S. Huttunen. 2002 [2003]. Brachytheciaceae (Bryophyta)—A family of sibling genera. *Arctoa* 11: 245–296.
- Kessler, M. 2000. Altitudinal zonation of Andean cryptogam communities. *J. Biogeogr.* 27: 275–282.
- Kruijer, H. 2002. Hypoterygiaceae of the world. *Blumea, Suppl.* 13: 1–388.
- Lewinsky, J. 1984. *Orthotrichum* Hedw. in South America 1. Introduction and taxonomic revision of taxa with immersed stomata. *Lindbergia* 10: 65–94.
- . 1987. *Orthotrichum* (Orthotrichaceae) in South America 2. Taxonomic revision of taxa with superficial stomata. *Mem. New York Bot. Gard.* 45: 326–370.
- Lutelyn, J. L. & S. P. Churchill. 2000. Vegetation of the tropical Andes. Pp. 281–310 in D. Lentz (editor), *Imperfect Balance: Landscape Transformations in the Pre-Columbian Americas*. Columbia University Press, New York.
- Magill, R. E. 1982. Exotic bryophytes. *Beih. Nova Hedwigia* 71: 317–322.
- Malta, N. 1926. The genus *Zygodon* Hook. et Tayl. *Latv. Univ. Bot. Darza Darbi* 1: 1–185.
- Menzel, M. 1992. Preliminary checklist of the mosses of Peru (Studies on Peruvian Bryophytes IV). *J. Hattori Bot. Lab.* 71: 175–254.
- Missouri Botanical Garden. Tropicos. <<http://www.tropicos.org>>, accessed 30 April 2009.
- Muñoz, J. 1999. A revision of *Grimmia* (Musci: Grimmiaceae) in the Americas. 1: Latin America. *Ann. Missouri Bot. Gard.* 86: 118–191.
- Ochi, H. 1980. A revision of the neotropical Bryoideae, Musci (first part). *J. Fac. Educ. Tottori Univ., Nat. Sci.* 29: 49–154.
- . 1981. A revision of the neotropical Bryoideae, Musci (second part). *J. Fac. Educ. Tottori Univ., Nat. Sci.* 30: 21–55.
- Orme, C. D. L., R. G. Davies, M. Burgess, F. Eigenbrod, N. Pickup, V. A. Olson, A. J. Webster, T.-S. Ding, P. C. Rasmussen, R. S. Ridgely, A. J. Stattersfield, P. M. Bennett, T. M. Blackburn, K. J. Gaston & I. P. F. Owens. 2005. Global hotspots of species richness are not congruent with endemism or threat. *Nature* 436: 1016–1019.
- Pittier, H. 1936. Los musgos de Venezuela. *Bol. Soc. Venez. Ci. Nat.* 3: 353–389.
- Pursell, R. A. 1973. Un censo de los musgos de Venezuela. *Bryologist* 76: 473–500.
- . 1994. Taxonomic notes on neotropical *Fissidens*. *Bryologist* 97: 253–271.
- . 2007. Fissidentaceae. *Fl. Neotrop.* 101: 1–278.
- Rodríguez-Mahecha, J. V., P. Salaman, P. Jørgensen, T. Consiglio, E. Forno, A. Telesca, L. Suárez, F. Arjona, F. Rojas, R. Bensted-Smith & V. H. Inchausty. 2004. Tropical Andes. Pp. 73–79 in R. A. Mittermeier, P. R. Gil, M. Hoffmann, J. Pilgrim, T. Brooks, C. Goettsch Mittermeier, J. Lamoreux & G. A. B. Da Fonseca (editors), *Hotspots Revisited: Earth's Biologically Richest and Most Endangered Terrestrial Ecoregions*. CEMEX, Mexico City.
- Shaw, A. J., C. J. Cox & B. Goffinet. 2005. Global patterns of moss diversity: Taxonomic and molecular inferences. *Taxon* 54: 337–352.
- Steere, W. C. 1948. Contributions to the bryogeography of Ecuador. I. A review of the species of Musci previously reported. *Bryologist* 51: 65–167.
- Touw, A. 1974. Some notes on taxonomic and floristic research on exotic mosses. *J. Hattori Bot. Lab.* 38: 123–128.
- Vergara, W., A. M. Deeb, A. M. Valencia, R. S. Bradley, B. Francou, A. Zarzar, A. Grünwaldt & S. M. Haeussling. 2007. Economic impacts of rapid glacier retreat in the Andes. *Eos Trans. Amer. Geophys. Union* 88: 261–268.
- Wilson, E. O. & F. M. Peter. 1988. *Biodiversity*. National Academy Press, Washington, D.C.
- APPENDIX 1. Summary of moss diversity for the tropical Andes, which encompasses 1376 species and 327 genera in 69 families. Families and genera are listed in alphabetical order. The numbers after families are genera/species, endemic species are in parentheses, and endemic genera are denoted by an asterisk. The number of specific and infraspecific Andean synonyms (929) is in brackets.
- Amblystegiaceae 19/33 (4) [16]
Amblystegium Schimp. in Bruch, Schimp. & W. Gümbel 4, *Anacamptodon* Brid. 1 [1], *Calliergonella* Loeske 1, *Campyliadelphus* (Kindb.) R. S. Chopra 1, *Campylium* (Sull.) Mitt. 1, *Campylophyllum* (Schimp.) M. Fleisch. 1 [2], *Cratoneuron* (Sull.) Spruce 1 [4], *Drepanocladus* (Müll. Hal.) G. Roth 5 [5], *Gradsteinia* Ochyra* 1 (1), *Hamatocaulis* Hedenäs 1, *Hygrohypnum* Lindb. 1, *Koponenia* Ochyra* 1 (1), *Leptodictyum* (Schimp.) Warnst. 1, *Pseudocalliergon* (Limpr.) Loeske 2 [1], *Sanionia* Loeske 1, *Scorpidium* (Schimp.) Limpr. 2 [2], *Straminergon* Hedenäs 1, *Vittia* Ochyra 2 (1) [1], *Warnstorfia* Loeske 5 (1)
- Andreaeaceae 2/9 (3) [2]
Acroschisma Lindl. 1, *Andreaea* Hedw. 8 (3) [2]
- Anomodontaceae 2/2 [1]
Anomodon Hook. & Taylor 1 [1], *Herpetineuron* (Müll. Hal.) Cardot 1
- Aulacomniaceae 1/1 [2]

- Aulacomnium* Schwägr. 1 [2]
Bartramiaceae 8/64 (23) [46]
Anacolia Schimp. 1 [1], *Bartramia* Hedw. 12 (5) [21], *Breutelia* (Bruch & Schimp.) Schimp. 20 (4) [13], *Conostomum* Sw. ex F. Weber & D. Mohr 3 (2) [2], *Flowersia* D. C. Griffin & W. R. Buck 2, *Leiomela* (Mitt.) Broth. 6 (4) [3], *Philonotis* Brid. 19 (8) [6], *Plagiopus* Brid. 1
Brachytheciaceae 14/45 (11) [57]
Aerolindigia M. Menzel 1 [4], *Brachythecium* Schimp. 13 (4) [25], *Eurhynchium* Bruch & Schimp. 4 [2], *Flabellidium* Herzog* 1 (1), *Mandoniella* Herzog* 1 (1), *Lindigia* Hampe* 1 (1) [1], *Meteoridium* (Müll. Hal.) Manuel 2 [4], *Palamocladium* Müll. Hal. 1, *Platyhypnidium* M. Fleisch. 2 (1), *Rhynchostegium* Bruch & Schimp. 4 (2), *Rozea* Besch. 2, *Squamidium* (Müll. Hal.) Broth. 7 [17], *Stenocarpidiopsis* M. Fleisch. ex Broth.* 1 (1), *Zelometeorium* Manuel 5 [4]
Bruchiaceae 2/3 (1)
Eobruchia W. R. Buck 1 (1), *Trematodon* Michx. 2
Bryaceae 11/130 (46) [93]
Acidodontium Schwägr. 11 (9) [5], *Anomobryum* Schimp. 9 (6) [3], *Brachymenium* Schwägr. 13 (2) [15], *Bryum* Hedw. 44 (9) [31], *Epipterygium* Lindb. 1 [1], *Leptobryum* (Schimp.) Wilson 2 [3], *Mielichhoferia* Nees & Hornsch. 4 (3) [1], *Orthodontium* Schwägr. 3 (1) [3], *Pohlia* Hedw. 11 [6], *Rhodobryum* (Schimp.) Limpr. 8 (1) [2], *Schizymenium* Harv. 24 (15) [23]
Calymperaceae 3/28 [23]
Calymperes Sw. ex F. Weber 8 [2], *Leucophanes* Brid. 1, *Syrropodon* Schwägr. 19 [21]
Catagoniaceae 1/2
Catagonium Müll. Hal. ex Broth. 2
Cryphaeaceae 5/16 (6) [12]
Cryphaea D. Mohr & F. Weber 10 (4) [12], *Dendrocryphaea* Paris & Schimp. ex Broth. 1 (1), *Dendropogonella* E. Britton 1, *Schoenobryum* Dozy & Molk. 2 (1), *Sphaerothereciella* M. Fleisch. 2
Daltoniaceae 4/31 (18) [9]
Adelothecium Mitt. 1, *Calypstrochaeta* Desv. 4 (3), *Daltonia* Hook. & Taylor 17 (11) [9], *Leskeodon* Broth. 9 (4)
Dicranaceae 28/129 (37) [107]
Amphidium Schimp. 1, *Aongstroemia* Bruch & Schimp. 3 [1], *Atractylocarpus* Mitt. 2 (1) [6], *Bryohumbertia* P. de la Varde & Thér. 1 [2], *Camptodontium* Dusén 2 (2), *Campylopediella* Cardot 1 [1], *Campylopus* Brid. 49 (12) [60], *Chorisodontium* (Mitt.) Broth. 3 (1) [5], *Dicranella* (Müll. Hal.) Schimp. 12 (5) [7], *Dicranodontium* Bruch & Schimp. 2 [1], *Dicranoweisia* Lindb. ex Milde 1, *Dicranum* Hedw. 2 [3], *Eucamptodontopsis* Broth. 1 (1), *Holodontium* (Mitt.) Broth. 1 [1], *Holomitrium* Brid. 10 (1) [7], *Hygrodicranum* Cardot 1 (1), *Leucoloma* Brid. 6 (1) [1], *Microcampylopus* (Müll. Hal.) M. Fleisch. 1 [2], *Microdus* Schimp. ex Besch. 6 (2), *Oreoweisia* (Bruch & Schimp.) De Not. 4 (2) [4], *Orthodicranum* (Bruch & Schimp.) Loeske 3 (1), *Pilopogon* Brid. 6 (3) [4], *Polymerodon* Herzog* 1 (1), *Pseudohyophila* Hilp.* 1 (1), *Rhabdoweisia* Bruch & Schimp. 3 [1], *Schliephackea* Müll. Hal. 2 (1), *Sphaerotherecium* Hampe 1 (1), *Symblepharis* Mont. 3 [1]
Diphysciaceae 1/2 (1) [1]
Diphyscium D. Mohr 2 (1) [1]
Ditrichaceae 10/21 (10) [10]
Astomiopsis Müll. Hal. 2 (1), *Bryomanginia* Thér. 1 [1], *Ceratodon* Brid. 2 [3], *Chrysoblastella* R. S. Williams 1 [2], *Distichium* Bruch & Schimp. 1, *Ditrichum* Hampe 6 (3) [4], *Pleuridium* Rabenh. 4 (4), *Rhamphidium* Mitt. 1, *Tristichium* Müll. Hal. 2 (1), *Wilsoniella* Müll. Hal. 1 (1)
Encalyptaceae 1/3 (1) [4]
Encalypta Hedw. 3 (1) [4]
Entodontaceae 3/11 (2) [8]
Entodon Müll. Hal. 8 (2) [4], *Erythrodontium* Hampe 2 [2], *Mesonodon* Hampe 1 [2]
Erpodiaceae 1/4
Erpodium (Brid.) Brid. 4
Eustichiaceae 1/1 [1]
Eustichia (Brid.) Brid. 1 [1]
Fabroniaceae 1/3 [8]
Fabronia Raddi 3 [8]
Fissidentaceae 1/46 (4) [28]
Fissidens Hedw. 46 (4) [28]
Fontinaliaceae 1/1 (1)
Fontinalis Hedw. 1 (1)
Funariaceae 3/12 (3) [31]
Entosthodon Schwägr. 9 (3) [28], *Funaria* Hedw. 2 [3], *Physcomitrium* (Brid.) Brid. 1
Gigaspermaceae 2/2
Lorentziella Müll. Hal. 1, *Neosharpiella* H. Rob. & Delgad. 1
Grimmiaceae 8/40 (8) [42]
Aligrimmia R. S. Williams* 1 (1), *Coscinodon* Spreng. 1 (1) [1], *Coscinodontella* R. S. Williams 1 (1), *Grimmia* Hedw. 15 (1) [27], *Jaffuelobryum* Thér. 2 (1) [1], *Ptychomitrium* Fűrnr. 6 [8], *Racomitrium* Brid. 7 (1) [2], *Schistidium* Bruch & Schimp. 7 (2) [3]
Hedwigiaceae 3/12 (1) [9]
Braunia Bruch & Schimp. 10 (1) [7], *Hedwigia* P. Beauv. 1, *Hedwigidium* Bruch & Schimp. 1 [2]
Helicophyllaceae 1/1
Helicophyllum Brid. 1
Hookeriaceae 1/1
Hookeria Sm. 1
Hylacomiaceae 2/3 (1) [1]
Loeskeobryum M. Fleisch. ex Broth. 1, *Pleurozium* Mitt. 2 (1) [1]
Hypnaceae 17/33 (5) [24]
Caribaeohypnum Ando & Higuchi 1, *Chrysohypnum* Hampe 2 [1], *Ctenidium* (Schimp.) Mitt. 1 [2], *Ectropothecium* Mitt. 2 (1) [1], *Herzogiella* Broth. 1 [1], *Hypnum* Hedw. 2 [2], *Isopterygium* Mitt. 5 (1) [7], *Mittenothamnium* Henn. 8 (3) [5], *Phyllodon* Bruch & Schimp. 1, *Platygyriella* Cardot 1, *Pseudotaxiphyllum* Z. Iwats. 1, *Puiggariopsis* M. Menzel 1, *Pylaisia* Bruch & Schimp. 1 [3], *Rhacopilopsis* Renaud & Cardot 1, *Syringothecium* Mitt. 1 [1], *Taxiphyllum* M. Fleisch. 3, *Vesicularia* (Müll. Hal.) Müll. Hal. 1 [1]
Hypopterygiaceae 1/1 [8]
Hypopterygium Brid. 1 [8]
Lembophyllaceae 2/7 (1) [5]
Orthostichella Müll. Hal. 4 [5], *Pilotrichella* (Müll. Hal.) Besch. 3 (1)
Leptodontaceae 1/3
Forsstroemia Lindb. 3
Lepyrodontaceae 1/1 [2]
Lepyrodon Hampe 1 [2]
Leskeaceae 6/11 (4) [7]
Haplocladium (Müll. Hal.) Müll. Hal. 1, *Leptopterigynandrum* Müll. Hal. 4 [2], *Leskea* Hedw. 3 (2) [1], *Leskeadelphus* Herzog* 1 (1) [3], *Lindbergia* Kindb. 1, *Pseudoleskea* Bruch & Schimp. 1 (1) [1]
Leucobryaceae 2/10 [3]
Leucobryum Hampe 7 [2], *Ochrobryum* Mitt. 3 [1]
Leucodontaceae 2/2 [3]
Leucodon Schwägr. 1 [2], *Pterogoniadelphus* M. Fleisch. 1 [1]
Leucomiaceae 2/4 [3]
Leucomium Mitt. 1 [2], *Rhynchostegiopsis* Müll. Hal. 3 [1]
Macromitriaceae 5/47 (11) [14]

- Cardotiella* Vitt 1, *Groutiella* Steere 7 [1], *Macrocoma* (Hornsch. ex Müll. Hal.) Grout 4 [2], *Macromitrium* Brid. 30 (11) [9], *Schlotheimia* Brid. 5 [2]
Meesiaceae 1/2
Meesia Hedw. 2
Meteoriaceae 6/8 [9]
Barbellopsis Broth. 1, *Floribundaria* M. Fleisch. 1, *Lepyrodontopsis* Broth. 1, *Meteorium* (Brid.) Dozy & Molk. 3 [7], *Toloxis* W. R. Buck 1 [2], *Trachypus* Reinw. & Hornsch. 1
Mniaceae 2/2 [1]
Mnium Hedw. 1, *Plagiomnium* T. J. Kop. 1 [1]
Myriniaceae 1/1 [2]
Helicodontium (Mitt.) A. Jaeger 1 [2]
Neckeraceae 9/26 (4) [34]
Homalia Brid. 1, *Isodrepanium* (Mitt.) E. Britton 1, *Neckera* Hedw. 6 (2) [12], *Neckeropsis* Reichardt 2, *Pinnatella* M. Fleisch. 1 [1], *Porotrichodendron* M. Fleisch. 3 [6], *Porotrichopsis* Broth. & Herzog* 1 (1), *Porotrichum* (Brid.) Hampe 10 (1) [14], *Thamnobryum* Nieuwl. 1 [1]
Octoblepharaceae 1/6
Octoblepharum Hedw. 6
Orthotrichaceae 2/51 (33) [37]
Orthotrichum Hedw. 18 (11) [16], *Zygodon* Hook. & Taylor 33 (22) [21]
Phyllogoniaceae 1/3 [5]
Phyllogonium Brid. 3 [5]
Pilotrichaceae 19/109 (49) [61]
Actinodontium Schwägr. 1, *Amblytropis* (Mitt.) Broth. 3 (2), *Brymela* Crosby & B. H. Allen 7 (5) *Callicostella* (Müll. Hal.) Mitt. 9 [1], *Callicostellopsis* Broth.* 1 (1), *Crossomitrium* Müll. Hal. 5 [2], *Cyclodictyon* Mitt. 15 (10) [5], *Helicoblepharum* (Spruce ex Mitt.) Broth. 3 (3), *Hemiragis* (Brid.) Besch. 1, *Hypnella* (Müll. Hal.) A. Jaeger 6 (1) [4], *Lepidopilidium* (Müll. Hal.) Broth. 2 [2], *Lepidopilum* (Brid.) Brid. 25 (15) [32], *Philophyllum* Müll. Hal. 1, *Pilotrichidium* Besch. 1, *Pilotrichum* P. Beauv. 8 (2) [3], *Stenodesmus* (Mitt.) A. Jaeger* 1 (1), *Stenodictyon* (Mitt.) A. Jaeger 1 [1], *Thamniopsis* (Mitt.) M. Fleisch. 9 (3) [2], *Trachyxiphium* W. R. Buck 10 (6) [9]
Plagiotheciaceae 1/4 [5]
Plagiothecium Bruch & Schimp. 4 [5]
Polytrichaceae 9/23 (10) [35]
Atrichum P. Beauv. 2 [2], *Notoligotrichum* G. L. Sm. 1, *Oligotrichum* DC. 1, *Pogonatum* P. Beauv. 7 (2) [22], *Polytrichadelphus* (Müll. Hal.) Mitt. 6 (6) [2], *Polytrichastrum* G. L. Sm. 1 [1], *Polytrichum* Hedw. 3 (1) [7], *Psilopilum* Brid. 1 (1), *Stereobryon* G. L. Sm. 1 [1]
Pottiaceae 42/172 (60) [101]
Aloina Kindb. 3 (2) [1], *Aloinella* Cardot 6 (5), *Anoetangium* Schwägr. 1 [1], *Barbula* Hedw. 10 (5) [1], *Bellibarbula* P. C. Chen 1, *Bryoerythrophyllum* P. C. Chen 10 (2) [8], *Calypogon* (Mitt.) Broth. 1, *Chenia* R. H. Zander 3 (2), *Crossidium* Jur. 1 (1), *Didymodon* Hedw. 26 (10) [12], *Dolotortula* R. H. Zander 1, *Erythrophyllastrum* R. H. Zander 1, *Erythrophyllopsis* Broth. 1 (1) [3], *Gertrudiella* Broth. 1 (1), *Globulinella* Steere 2 (1), *Gymnostomiella* M. Fleisch. 1, *Gymnostomum* Nees & Hornsch. 1, *Hennediella* Paris 9 (5) [5], *Hymenostylium* Brid. 1, *Hyophila* Brid. 1, *Leptodontiella* R. H. Zander & E. H. Hegew.* 1 (1), *Leptodontium* (Müll. Hal.) Hampe ex Lindb. 17 (4) [29], *Mironia* R. H. Zander 1 [1], *Molendoa* Lindb. 1 [2], *Plaubelia* Brid. 1, *Pleurochaete* Lindb. 1 [1], *Pseudocrossidium* R. S. Williams 9 (3) [2], *Pseudosymblypharis* Broth. 1, *Rhexophyllum* Herzog 1 [1], *Sagenotortula* R. H. Zander 1 [1], *Saitobryum* R. H. Zander 1 [1], *Scopelophila* (Mitt.) Lindb. 2 [2], *Streptocalypta* Müll. Hal. 1, *Streptopogon* (Taylor) Wilson ex Mitt. 4 [7], *Streptotrichum* Herzog* 1 (1), *Syntrichia* Brid. 26 (10) [15], *Timmiella* (De Not.) Limpr. 2, *Tortella* (Lindb.) Limpr. 5 (2), *Tortula* Hedw. 4 (1) [3], *Trachyodontium* Steere* 1 (1), *Trichostomum* Bruch 7 (2) [4], *Weissia* Hedw. 3 [1]
Prionodontaceae 1/5 (1) [16]
Prionodon Müll. Hal. 5 (1) [16]
Pterobryaceae 9/17 (3) [6]
Calypothecium Mitt. 2 [1], *Henicodium* (Müll. Hal.) Kindb. 1, *Jaegerina* Müll. Hal. 1, *Orthostichidium* Müll. Hal. ex Dusén 1 [1], *Orthostichopsis* Broth. 3 [1], *Pirella* Cardot 5 (1) [1], *Pterobryon* Hornsch. 2 (1) [2], *Pterobryopsis* M. Fleisch. 1 (1), *Renauldia* Müll. Hal. ex Renauld 1
Racopilaceae 1/2 [2]
Racopilum P. Beauv. 2 [2]
Regmatodontaceae 1/1 [1]
Regmatodon Brid. 1 [1]
Rhacocarpaceae 1/4 (1) [3]
Rhacocarpus Lindb. 4 (1) [3]
Rhizogoniaceae 4/5 [2]
Hymenodon Hook. f. & Wilson 1, *Leptotheca* Schwägr. 1 [1], *Pyrrhobryum* Mitt. 2, *Rhizogonium* Brid. 1 [1]
Rhytidiaceae 1/1
Rhytidium (Sull.) Kindb. 1
Rigodiaceae 1/1 [3]
Rigodium Kunze ex Schwägr. 1 [3]
Rutenbergiaceae 1/1
Pseudocryphaea E. Britton ex Broth. 1
Seligeriaceae 2/3 (1)
Blindia Bruch & Schimp. 2 (1), *Brachyodontium* Fürnr. 1
Sematophyllaceae 14/52 (21) [11]
Acroporium Mitt. 3 (1) [2], *Allioniellopsis* Ochyra* 1 (1), *Aptychella* (Broth.) Herzog 1 [4], *Aptychopsis* (Broth.) M. Fleisch. 1 (1), *Donnellia* Austin 2, *Heterophyllum* (Schimp.) Kindb. 1, *Meiothecium* Mitt. 2, *Pterogonidium* Müll. Hal. 1, *Schroeterella* Herzog* 1 (1), *Sematophyllum* Mitt. 24 (14) [4], *Taxithelium* Spruce ex Mitt. 1 [1], *Timotimius* W. R. Buck* 1 (1), *Trichosteleum* Mitt. 10 (1), *Wijkia* H. A. Crum 3 (1)
Sorapillaceae 1/1 (1)
Sorapilla Spruce & Mitt. 1 (1)
Sphagnaceae 1/61 (35) [5]
Sphagnum L. 61 (35) [5]
Splachnaceae 5/12 (3) [2]
Brachymitrium Taylor 4 (1) [1], *Splachnum* Hedw. 2, *Tayloria* Hook. 4 (2) [1], *Tetraplodon* Bruch & Schimp. 1, *Voitia* Hornsch. 1
Splachnobryaceae 1/1
Splachnobryum Müll. Hal. 1
Stereophyllaceae 6/10 (2) [2]
Entodontopsis Broth. 4 [1], *Eulacophyllum* W. R. Buck & Ireland 1, *Juratzkaea* Lorentz 1, *Pilosium* (Müll. Hal.) M. Fleisch. 1, *Sciuroleskea* Hampe ex Broth.* 2 (2) [1], *Stereophyllum* Mitt. 1
Symphyodontaceae 1/1 [1]
Symphyodon Mont. 1 [1]
Thuidiaceae 3/15 (1) [2]
Pelekium Mitt. 8 (1) [3], *Rauarella* Reimers 2 [1], *Thuidium* Bruch & Schimp. 5 [1]

ANDEAN SPECIATION AND
VICARIANCE IN NEOTROPICAL
MACROCARPAEA
(GENTIANACEAE–HELIEAE)¹

Lena Struwe,^{2,3} Scott Haag,⁴ Einar Heiberg,⁵ and
Jason R. Grant⁶

ABSTRACT

The genus *Macrocarpaea* (Griseb.) Gilg (Gentianaceae, Helieae) is among the largest woody genera of tropical gentians, with most of its species occurring in the wet mountainous forests of the Andes. Phylogenetic and dispersal-vicariance analyses (DIVA) of 57 of the 105 currently recognized species in the genus, using two data sets from nuclear DNA (ITS and 5S-NTS sequences) and morphology, show a single origin of the Andean species from an ancestral distribution that includes southeastern Brazil. Within the Andes, species divide into two major clades: (1) northern species from the cordilleras of northern Ecuador, Colombia, and Venezuela; and (2) southern species of the Andean Amotape–Huancabamba Zone in Ecuador and Peru, as well as the Andes of central and southern Peru and Bolivia. The Amotape–Huancabamba Zone is supported as the ancestral area for *Macrocarpaea* within the Andes. There are repeated speciation patterns within the Andes, and three Mesoamerican species derive from the northern clade, as is the single sampled species from the Guayana Shield. The position of the subclade of the three Caribbean species is less certain, but it currently nests among Andean species. An Atlantic coastal Brazilian clade is placed as sister group to all other *Macrocarpaea*, providing further support for an ancestral refuge in southeastern Brazil for the Helieae. The biogeographic analysis showed that local speciation is more common than long-distance dispersal, and allopatric speciation is more common than sympatric speciation. Using detailed, georeferenced herbarium collection data, patterns in environmental characteristics between clades and sister species were analyzed with Spatial Evolutionary and Ecological Vicariance Analysis (SEEVA), utilizing geographic information system (GIS) and statistical methods. Sister clades and taxa were evaluated for statistical significance in variables such as annual rainfall and temperature, elevation, temperature and rainfall seasonality, geological bedrock age, and soil type to evaluate ecological vicariance between sister groups. The results indicate that there are no general patterns for each variable, but that there are many significant divergences in ecological niches between both larger sister groups and sister species, and ecological niche conservatism was also observed when subsequent nodes in the phylogeny were compared.

Key words: Biogeography, ecology, Gentianaceae, *Macrocarpaea*, Neotropics, niche, South America, speciation, vicariance.

The tropical Andes are one of the most biologically diverse areas in the world and a biodiversity hotspot (Myers et al., 2000; Rodríguez-Mahecha et al., 2004a, b; Jørgensen et al., 2007; Morawetz & Raedig, 2007), despite being a relatively young part of South America

due to recent geological uplift. Biodiversity in South America and Andean biogeography has been reviewed by Burnham and Graham (1999) and Young et al. (2002), highlighting the complex history, topography, and vegetation patterns of the Andes. The high

¹This study was funded by the National Science Foundation (grant 0317612) and USDA-Rutgers University (Hatch no. 102211) to L.S., and the Swiss National Science Foundation (grants 3100-052885, 3100-065395) and Swiss Academy of Sciences (SCNAT) to J.R.G. The authors wish to express their sincere thanks to Peter Smouse and Richard G. Lathrop for constructive discussions and collaboration with SEEVA development. We also thank the following herbaria and their staff for their valuable help in accessing their collections and providing information: AAU, AFP (Herbario “Álvaro Fernández Pérez,” Popayán, Cauca, Colombia), ALA, B, BM, BP, BR, BRIT, BSB, C, CAS, CAUP, CHOCO, CHRB, COAH, COL, CONN, CR, CUVC, CUZ, DAV, DUKE, E, EHH, F, FAUC, FI, FLAS, FMB, FR, G, GB, GH, GOET, HAC, HAL, HAM, HAO, HUA, HUCP, HUQ, HUT, IAN, INB, INPA, JAUM, JBSD, JE, K, L, LD, LINN, LOJA, LPB, LS, M, MA, MANCH, MARY, MBM, MEDEL, MER, MG, MICH, MIN, MO, MOL, MSB, MU, MY, NA, NEU, NO, NSW, NY, OXF, P, PH, PORT, PR, PRC, Q, QAP, QCA, QCNE, QPLS, QUSF, R, RB, RNG, S, SBBG, SEL, SP, SPF, TEX, U, UC, UCWI, UDBC, UPCB, UPS, UPTC, US, USM, VALLE, VEN, W, WIS, WU, YU, and Z.

²Department of Ecology, Evolution, and Natural Resources, Rutgers University, 14 College Farm Road, New Brunswick, New Jersey 08901, U.S.A. struwe@aesop.rutgers.edu.

³Department of Plant Biology and Pathology, Rutgers University, 59 Dudley Road, New Brunswick, New Jersey 08901, U.S.A.

⁴Center for Remote Sensing and Spatial Analysis, Rutgers University, 14 College Farm Road, New Brunswick, New Jersey 08901-8551, U.S.A.

⁵Department of Clinical Physiology, Lund University Hospital, 221 85, Lund, Sweden.

⁶Laboratoire de botanique évolutive, Institut de Biologie, Université de Neuchâtel, rue Emile-Argand 11, CP 158, 2009 Neuchâtel, Switzerland.

doi: 10.3417/2008040

biodiversity has been explained through habitat diversity resulting from large differences in bedrock types, soils, climate, and elevation, which are also fragmented due to the dissected topography. Species have spread north and south along this jagged mountain chain, and also up and down in elevation during colder times through repeated glaciations. Both allopatric and sympatric speciation processes could have resulted in such large species diversity. Generally speaking, the theory behind sympatric speciation suggests that competition among populations led to subsequent ecological niche divergence, whereas allopatric speciation invoked a spatial barrier and not necessarily any ecological niche separation (Mayr, 1963). This is applicable not only to extant sister species pairs, but also to deeper clades in the phylogeny that represent ancient allopatric or sympatric events.

Progress in methodological developments has now made it possible to evaluate phylogenetic patterns and speciation processes in a historical and spatial context including ecological data. In this study, we use molecular and morphological data for phylogenetic reconstruction using parsimony criteria, dispersal-vicariance analysis (DIVA) for reconstruction of ancestral areas (Ronquist, 1997), and Spatial Evolutionary and Ecological Vicariance Analysis (SEEVA) (Struwe, 2008).

In this paper, we will evaluate several hypotheses based on a comprehensive data set from *Macrocarpaea* (Griseb.) Gilg.

1. Continental patterns: What is the relationship between species in the Andes to species in Mesoamerica, the Caribbean, southeastern Brazil, and tepuis of the Guayana Shield?
2. Andean patterns: What is the ancestral distribution area in the Andes and what large-scale Andean biogeographic patterns are present?
3. Speciation patterns: Is sympatric or allopatric speciation most common in Andean species? Is dispersal or vicariance most common in Andean species?
4. Ecological niche patterns: Does allopatric speciation indicate a relatively larger shift in ecological niche characteristics than sympatric speciation that occurs within the same area? Do vicariant (allopatric) versus overlapping (sympatric) sister taxa have similar or divergent ecological niches?

Our study group, *Macrocarpaea* (Gentianaceae, Helieae), occurs in mountainous regions of the Neotropics at (30–)1500–3000(–3800) m elevation. It is composed of woody shrubs, small trees (up to 10 m), and herbs (one species; *M. rubra* Malme) with large (up to 7 cm long), campanulate, white, yellow, to

green flowers that are visited diurnally by hummingbirds, butterflies, and insects, and nocturnally by bats and moths (Grant & Struwe, 2001; Grant, pers. obs.). Its woody habit is uncommon in the Gentianaceae and led to a comparative study of its wood anatomy indicating secondary derivation of woodiness from herbaceous ancestors (Carlquist & Grant, 2005). With 105 species currently recognized, *Macrocarpaea* is by far the most species-rich genus in the Helieae, while the majority of genera in this tribe are either monotypic or have less than 10 species, e.g., *Celiantha* Maguire and *Yanomamua* J. R. Grant, P. J. M. Maas & Struwe (Struwe et al., 2002; Grant et al., 2006). During monographic studies on *Macrocarpaea*, more than 3500 herbarium sheets were examined, resulting in the description of 70 new species (Grant & Struwe, 2001, 2003; Grant, 2003, 2004, 2005, 2007, 2008; Grant & Weaver, 2003). Fieldwork by Grant, especially in the Huancabamba region of Ecuador and Peru, continues to uncover new species that are often cryptically different from one another when seen as herbarium specimens, but are otherwise clearly distinct in the field. Likewise, molecular phylogenetics of *Macrocarpaea* (Struwe et al., 2009) has given strong support for its monophyly, for the establishment of an infrageneric classification (Grant, 2005), and to the understanding of difficult species complexes.

Macrocarpaea has a broad distribution in mountainous regions of the Neotropics and is comprised of generally narrowly endemic species. It occurs principally in the Andes (87 species from Venezuela, Colombia, Ecuador, Peru, and Bolivia), with outlying species in the Pantepui of the Guayana Shield (six species), in southern Mesoamerica (five species in Costa Rica and Panama), in the Atlantic forest of southeastern Brazil (four species comprising section *Tabacifoliae* Ewan), and in the Greater Antilles of the Caribbean (three species: one each from Cuba, Hispaniola, and Jamaica). The three main centers of diversity are in the Colombian Andes (section *Macrocarpaea*, where 58% of the species of that section occur), the Amotape–Huancabamba region straddling southern Ecuador and northern Peru (section *Choriophylla* (Griseb.) J. R. Grant, 74% of its species), and the central Peruvian Andes (section *Magnolifoliae* Ewan, 50% of its species). The genus is absent from lowland Amazonia, Mexico, Mesoamerica north of Costa Rica, and southern temperate South America. Here, we use *Macrocarpaea* as a model for understanding South American, and particularly Andean, speciation, biogeography, and dispersal. Because *Macrocarpaea* has many narrowly distributed Andean endemics, it is an excellent candidate for this kind of study.

MATERIALS AND METHODS

PHYLOGENETIC DATA AND ANALYSES

Fifty-seven of 105 total species (54%) of *Macrocarpaea*, representing all sections as defined by Grant (2005), were included in the phylogenetic analysis (Table 1). Five outgroups were selected for orientation of the phylogenetic trees (Nixon & Carpenter, 1993), based on previous phylogenetic work in the Gentianeaceae and all of tribe Helieae using *trnL* and *matK* chloroplast data as well as nuclear ITS markers (Struwe et al., 2002, 2009). Outgroups used include *Symbolanthus jasonii* J. E. Molina & Struwe from the *Symbolanthus* G. Don subclade of Helieae, and *Chorisepalum psychotrioides* Ewan and three species of *Tachia* Aubl. (*T. grandiflora* Maguire & Weaver, *T. guianensis* Aubl., and *T. occidentalis* Maguire & Weaver) assigned to the *Macrocarpaea* subclade (Struwe et al., 2002).

The DNA data in this study were developed for a detailed phylogenetic study of the genus by Grant. For molecular data we used two different nuclear genomic areas, ITS and NTS (for 5S RNA [5S-NTS]). These regions have successfully resolved phylogenetic relationships in tribe Helieae on both generic and tribal scales in the past (Struwe et al., 2002, 2009; Gould & Struwe, 2004). Additional sequences for 57 species of *Macrocarpaea* and the selected outgroups were downloaded from GenBank (see Table 1 for GenBank numbers). In total, 47 ITS and 56 5S-NTS taxon-specific sequences were obtained from *Macrocarpaea*. Sequences were aligned using ClustalX (Thompson et al., 1997) and Se-Al v.2.0 for Macintosh (Rambaut, 2002).

In addition to molecular data, nine morphological characters were coded for all included species (Table 2), and these were primarily selected from pollen and seed surface structure (Grant & Struwe, 2001, 2003; Grant, 2003, 2004, 2005, 2007; Grant & Weaver, 2003). Four morphological seed types were identified by Grant (2005), including two types without wings (flattened and rimmed), and two with wings (perimetrically winged and winged). Character 1 refers to the general shape of the seeds, varying from three-dimensional (rectangular to spheroid) to completely flattened, as does character 4 separating seed types with either a square or long-linear outline. Character 2 refers to the presence or absence of seed wings, and character 3 is coded based on whether these wings occur on opposite ends as in a bowtie (winged type) or surround the seed entirely (perimetrically winged). Character 5 is the weight of an individual seed in milligrams, generally less than 0.1 mg in *Macrocarpaea* and greater than 0.1 mg in *Chorisepalum* Gleason & Wodehouse, *Tachia*, and

Symbolanthus. Character 6 refers to features of the pollen exine surface, and character 9 identifies whether the pollen is shed as monads or as tetrads or polyads. Character 7 differentiates the axillary flower position of *Tachia*, as compared to all other genera that have multiflowered terminal inflorescences, and character 8 codes for the color of the corollas. Character states were treated as unordered, and characters were regarded of equal weight. The two DNA alignments were combined with the data matrix of nine morphological characters and analyzed together simultaneously.

The phylogenetic, unconstrained parsimony analysis was performed in Winclada and NONA (Goloboff, 1999; Nixon, 1999, 2002) using 500 random replicates, five starting trees per replicate, MaxTrees as 10,000, and the tree-swapping algorithm was multiple tree bisection-reconnection (TBR) + TBR. Bootstrapping was done with 300 replicates in PAUP* v.4 (Swofford, 2000).

COLLECTION DATA

A total of 794 georeferenced herbarium collection records of the 57 *Macrocarpaea* species included were entered into an existing FileMaker Pro 7.0 (Claris Pro, Santa Clara, California) database. Each locality was georeferenced using printed and online maps, atlases, and gazetteers. Identification of all collections was confirmed by Grant, and an exsiccatae list with the georeferenced coordinates is available upon request. Only recorded locations known to the nearest minute, nearest second, or label with global positioning system (GPS) coordinates were included in the analysis. Coordinates were converted to a point shapefile in ArcGIS v. 9.2 (ESRI, Redlands, California), and distribution maps of each species and the genus were produced.

BIOGEOGRAPHIC ANALYSIS

Nodes present in the selected most parsimonious tree were classified as either representing sympatric, partially sympatric, or allopatric species distributions based on data from individual species maps. This classification was used in comparing impact indices and *P* values for environmental species and clade data during the SEEVA analysis.

For the DIVA analysis, the total genus distribution was divided into 10 biogeographic units based on age, spatial structure and geographic connectivity, and geological coherence. The identified areas were: A, southeastern Brazil; B, Pantepui of the Guayana Shield; C, Greater Antilles of the Caribbean; D, Mesoamerica; E, Cordillera Central in Colombia and

Cordillera Oriental in Ecuador; F, Chocó and Cordillera Occidental in Colombia and Ecuador; G, Cordillera Oriental and Mérida in Colombia and Venezuela; H, Amotape–Huancabamba region in Ecuador and Peru; I, Cordillera Central in central Peru; J, Bolivia and Cordillera Central in southern Peru; K, Amazon Basin in Brazil, Colombia, Peru, and Venezuela. A map of the areas in northwestern South America is presented in Figure 1.

Areas were delimited based on spatial, historical, and geological features; some outliers were clearly disjunct, such as the Caribbean (C), tepuis on the Guayana Shield (B), and southeastern Brazil (A). For areas that are part of the Andean mountain chain and the Mesoamerican land bridge, their distinction is less obvious. The boundary between Mesoamerica (D) and the Chocó and Cordillera Occidental in northwestern Colombia (F) follows evidence that lowland Darién in eastern Panama has a stronger geological and historical connection to northern South America than to western Panama (Clapperton, 1993). The three cordilleras in Colombia and two in northern Ecuador were treated as separate areas because deep valleys separate the mountain ranges. The Cordillera de Mérida range in Venezuela is an extension of the Cordillera Oriental of Colombia and is included in the same area. The division between the Andean area of the Amotape–Huancabamba Zone (H) to the south and the Andean areas in northern Ecuador and Colombia (E + F) is correlated with the Amotape Cross, a geological shear zone at ca. 3°S in the continental crust of the South American Plate (Clapperton, 1993). The southernmost limit of area H is from Río Chicama on the western side and Río Huallaga on the eastern side of the Andes and corresponds to a disjunction zone found in other biogeographic studies (Weigend, 2002). The two southernmost Andean areas (I, J) in Peru and Bolivia are separated at the latitude of Río Pisco and Río Entero, which corresponds to the geological Abancay Deflection, another shear zone (Clapperton, 1993).

A dispersal–vicariance analysis was run using the software DIVA v. 1.1 (Ronquist, 1996), limiting the maximum number of optimized areas at each node to three (maxareas = 3) and optimizing dispersal and vicariance events on a selected most parsimonious tree, because DIVA requires a fully resolved tree for its analysis. This tree was selected from all most parsimonious trees by being overall the most similar to the majority-rule consensus tree. The DIVA distribution matrix is shown in Table 3. The DIVA optimization method uses the parsimony criterion to limit the numbers of events (– steps) per tree based on the distribution of each species. Ancestral areas were optimized at each internal node in a way that limits

vicariance and dispersal events as far as possible (i.e., it provides the simplest explanation of the current distribution data given the phylogeny). At several nodes, there were several equally likely area optimizations and we selected from among these based on additional data from geological and spatial information.

SEEVA ANALYSIS

The theoretical background and statistical explanations and justifications for SEEVA are outlined in Struwe (2008) and Heiberg and Struwe (2008), with a short overview given here. Environmental data were extracted using GIS from all georeferenced collection localities of each species. Each variable was divided into four or five categories that were either quantitative (e.g., rainfall amounts, in equally sized quartiles for the data overall) or qualitative (e.g., soil types) depending on data set. A table was prepared in Microsoft Excel (Microsoft, Redmond, Washington) that lists the number of collections per species for each variable (e.g., annual rainfall) and within each variable, for each category (e.g., 1–340, 341–732, 733–1277, 1278–4000 mm). The table was imported into the software SEEVA v. 0.4 (Heiberg, 2008) for statistical analysis. The selected phylogenetic tree was then imported into SEEVA.

Environmental point data for nine variables were extracted for the 794 *Macrocarpaea* collections using the following base layers in ArcGIS 9.2: elevation (U.S. Geological Survey; unit: m; format: grid; scale: 30 arc second), soil type (ESRI/ArcAtlas; format: vector; scale: 1:5–10,000,000), geology (unit: bedrock geologic age; U.S. Geological Survey; format: vector; scale: 1:1–5,000,000), annual mean temperature (BIO1; unit: °C × 10; format: grid; scale: 1 km), temperature seasonality (BIO4; standard deviation × 100; format: grid; scale: 1 km), minimum temperature of coldest month (BIO6; unit: °C × 10; format: grid; scale: 1 km), annual precipitation (BIO12; unit: mm; format: grid; scale: 1 km), precipitation of driest month (BIO14; unit: mm; format: grid; scale: 1 km), precipitation seasonality (BIO15; unit: mm; format: grid; scale: 1 km), and precipitation seasonality (coefficient of variation; format: grid; scale: 1 km). All climate data were retrieved from WORLDCLIM (Hijmans et al., 2005).

For each node in the phylogenetic tree, extracted environmental data were pooled to represent data for each monophyletic group (clade) and compared with their sister group for each node. Ecologic data are measured for statistically significant differences between clades based on the distribution in the four or five categories. All variables were analyzed indepen-

Table 1. Voucher and GenBank accession numbers for 5S-NTS and ITS sequences of *Macrocarpaea* and outgroups used for the phylogenetic analysis. N/A indicates sequences not available.

Taxon	Voucher	5S-NTS	ITS
<i>Macrocarpaea angelliae</i> J. R. Grant & Struwe	Ecuador, <i>J. R. Grant</i> 4289 (NY)	EU541681	AY397760, AY397761
<i>M. apparatus</i> J. R. Grant & Struwe	Ecuador, <i>J. R. Grant</i> 4002 (NY)	EU541683	DQ401413
<i>M. arborescens</i> Gilg	Ecuador, <i>J. R. Grant</i> 4084 (NY)	EU541686	EU528076
<i>M. auriculata</i> Weaver & J. R. Grant	Costa Rica, <i>R. L. Wilbur & Almeda</i> 16828 (F)	EU541688	N/A
<i>M. bangiana</i> Gilg	Bolivia, <i>S. G. Beck</i> 8745 (NEU)	EU541690	EU528078
<i>M. bubops</i> J. R. Grant & Struwe	Ecuador, <i>J. R. Grant</i> 4046 (NY)	EU541692	EU528081
<i>M. chthonotropa</i> J. R. Grant	Peru, <i>V. Quipuscoa</i> 2044 (F)	EU541694	N/A
<i>M. cinchonifolia</i> (Gilg) Weaver	Bolivia, <i>S. G. Beck</i> 24780 (NY)	EU541696	EU528084
<i>M. cochabambensis</i> Gilg-Ben.	Bolivia, <i>A. Gentry</i> 44200 (NY)	EU541697	EU528085
<i>M. densiflora</i> (Benth.) Ewan	Colombia, <i>K. von Sneidern</i> 2523 (S)	EU541700	EU528087
<i>M. dies-viridis</i> J. R. Grant	Ecuador, <i>J. R. Grant</i> 4352 (NY)	EU541702	EU528089
<i>M. domingensis</i> Urb. & Ekman	Dominican Republic, <i>D. Kolterman s.n.</i> (JBSD)	EU541704	EU528091
<i>M. elix</i> J. R. Grant	Ecuador, <i>G. Harling & Andersson</i> 23442 (MO)	EU541706	EU528094
<i>M. ericii</i> J. R. Grant	Peru, <i>E. Rodriguez</i> 2926 (HUT)	EU541707	EU528093
<i>M. fortisiana</i> J. R. Grant	Peru, <i>D. McCarroll</i> 128 (NY)	EU541709	EU528095
<i>M. gattaca</i> J. R. Grant	Ecuador, <i>J. R. Grant</i> 4209 (NY)	EU541710	DQ401414
<i>M. gaudialis</i> J. R. Grant	Colombia, <i>R. E. Weaver</i> 2650 (GH)	EU541713	EU528097
<i>M. glabra</i> (L. f.) Gilg	Colombia, <i>J. R. Grant</i> 4310 (NY)	EU541714	EU528098
<i>M. glaziovii</i> Gilg	Brazil, <i>B. Rezende Silva</i> 1318 (NEU)	EU541774	N/A
<i>M. gondoloides</i> J. R. Grant	Ecuador, <i>G. Tipaz</i> 1051 (MO)	EU541716	N/A
<i>M. harlingii</i> J. S. Pringle	Ecuador, <i>J. R. Grant</i> 4049 (NY)	EU541721	EU528104
<i>M. innarrabilis</i> J. R. Grant	Ecuador, <i>F. Luisier</i> 2 (LOJA)	EU541723	EU528106
<i>M. jactans</i> J. R. Grant	Ecuador, <i>J. Clark</i> 8927 (NY)	EU541725	EU528108
<i>M. jensii</i> J. R. Grant & Struwe	Ecuador, <i>J. R. Grant</i> 4047 (NY)	EU541724	EU528107
<i>M. kuelap</i> J. R. Grant	Peru, <i>J. R. Grant</i> 3942 (NY)	EU541726	EU528109
<i>M. lenae</i> J. R. Grant	Ecuador, <i>J. R. Grant</i> 4013 (NY)	EU541727	EU528110
<i>M. luna-gentiana</i> J. R. Grant & Struwe	Ecuador, <i>J. R. Grant</i> 4028 (NY)	EU541728	EU528111
<i>M. luteynii</i> J. R. Grant & Struwe	Colombia, <i>I. Cabrera & H. van der Werff</i> 15769 (U)	EU541730	N/A
<i>M. macrophylla</i> (Kunth) Gilg	Colombia, <i>J. R. Grant</i> 4312 (NY)	EU541735	EU528113
<i>M. maguirei</i> Weaver & J. R. Grant	Peru, <i>B. Maguire</i> 61569 (NY)	EU541736	EU528114
<i>M. micrantha</i> Gilg	Peru, <i>J. R. Grant</i> 3966 (NY)	EU541737	EU528116
<i>M. neblinae</i> Maguire & Steyerm.	Venezuela, <i>B. Maguire</i> 36886 (NY)	EU541739	N/A
<i>M. nicotianifolia</i> Weaver & J. R. Grant	Colombia, <i>A. S. Barclay</i> 3402 (US)	EU541740	EU528118
<i>M. noctiluca</i> J. R. Grant & Struwe	Ecuador, <i>J. R. Grant</i> 4003 (NY)	EU541742	EU528121
<i>M. normae</i> J. R. Grant	Peru, <i>K. García</i> 267 (NEU)	EU541743	EU528122
<i>M. obtusifolia</i> (Griseb.) Gilg	Brazil, <i>W. Thomas</i> 14304 (NY)	EU541775	EU528125
<i>M. opulenta</i> J. R. Grant	Ecuador, <i>J. R. Grant</i> 4347 (NY)	EU541746	EU528124
<i>M. ostentans</i> J. R. Grant	Peru, <i>B. Wallnöfer</i> 12968 (U)	EU541747	EU528128
<i>M. pachyphylla</i> Gilg	Colombia, <i>M. L. Bristol</i> 1429 (GH)	EU541748	EU528129
<i>M. pachystyla</i> Gilg	Peru, <i>J. Schunke-Vigo</i> 5298 (NY)	EU541751	EU528130
<i>M. pajonalis</i> J. R. Grant	Peru, <i>M. Weigend</i> 545 (NY)	EU541749	N/A
<i>M. papillosa</i> Weaver & J. R. Grant	Venezuela, <i>R. E. Weaver</i> 2629 (GH)	EU541750	EU528131
<i>M. pinetorum</i> Alain	Cuba, <i>Bisse</i> 49708 (HAJB)	EU541753	EU528133
<i>M. pringleana</i> J. R. Grant	Ecuador, <i>F. Luisier</i> 1 (NY)	EU541755	EU528134
<i>M. revoluta</i> (Ruiz & Pav.) Gilg	Peru, <i>M. Weigend</i> 5288 (NY)	EU541756	EU528135
<i>M. robin-fosteri</i> J. R. Grant	Peru, <i>M. Weigend</i> 5777 (B)	EU541757	EU528136
<i>M. rubra</i> Malme	Brazil, <i>M. Reginato</i> 755 (NEU)	N/A	EU528138
<i>M. sodiroana</i> Gilg	Ecuador, <i>J. R. Grant</i> 4210 (NY)	EU541758	EU528140
<i>M. stenophylla</i> Gilg	Peru, <i>J. R. Grant</i> 3932 (NY)	EU541762	EU528142
<i>M. subcaudata</i> Ewan	Costa Rica, <i>R. L. Wilbur & Almeda</i> 16828 (DUKE)	EU541763	EU528143
<i>M. subsessilis</i> Weaver & J. R. Grant	Ecuador, <i>J. R. Grant</i> 4020 (NY)	EU541765	EU528144
<i>M. tahuantinsuyuana</i> J. R. Grant	Peru, <i>F. Woytkowski</i> 6672A (MO)	EU541766	N/A

Table 1. Continued.

Taxon	Voucher	5S-NTS	ITS
<i>M. thamnoides</i> (Griseb.) Gilg	Jamaica, <i>P. Acevedo-Rodríguez</i> 9700 (NY)	EU541767	N/A
<i>M. valerioi</i> Standl.	Costa Rica, <i>S. Hill</i> 17751 (NY)	EU541769	EU528148
<i>M. viscosa</i> (Ruiz & Pav.) Gilg	Peru, <i>M. Weigend</i> 5429 (NY)	EU541770	EU528149
<i>M. weigendiorum</i> J. R. Grant	Peru, <i>M. Weigend</i> 5363 (NY)	EU541771	EU528150
<i>M. zophoflora</i> Weaver & J. R. Grant	Peru, <i>J. J. Wurdack</i> 1618 (NY)	EU541772	N/A
<i>Chorisepalum psychotrioides</i> Ewan		N/A	EU709793
<i>Symbolanthus jasonii</i> J. E. Molina & Struwe	Ecuador, <i>J. R. Grant</i> 4350 (NY)	N/A	EU528151
<i>Tachia grandifolia</i> Maguire & Weaver		DQ401429	DQ401418
<i>T. guianensis</i> Aubl.		DQ401430	DQ401420
<i>T. occidentalis</i> Maguire & Weaver		DQ401427	DQ401423

dently through a modified chi-square analysis that gives an impact index (*i*) that measures the magnitude in trends and differences between clades on a scale from 0 to 1 for each variable and each node. *P* values were calculated using Fisher's exact test. Statistical significance was established at $P < 0.05$.

RESULTS

PHYLOGENETIC DATA AND ANALYSES

The lengths of the alignments were 687 nucleotides for ITS and 599 nucleotides for 5S-NTS. The combined molecular analysis yielded 160 most parsimonious trees (1252 steps, consistency index [CI] = 0.65, retention index [RI] = 0.74; Fig. 2). Five major clades are identified as monophyletic groups (Fig. 2, I–VI). Clade I represents three species with flattened seeds and pollen of the *Glabra*-type from southeastern Brazil (*Macrocarpaea* sect. *Tabacifoliae* sensu Grant, 2005; for distribution data, see Figs. 3, 4) and is sister to the rest of the genus. Next is a large dichotomy that is poorly supported between northern species with rimmed or perimetrically winged seeds and *Glabra*-type pollen (clades II and III) and southern species with winged or perimetrically winged seeds and *Corymbosa*- or *Glabra*-type pollen (clades V and VI). The Caribbean clade (clade IV) with rimmed seeds and *Glabra*-type pollen is weakly supported as sister to the clade with the more southern species. Clades II and III are each monophyletic, potentially sister groups, and include species primarily from the northern Andes, the tepuis, and Mesoamerica. Clades II, III, and IV correspond together to *Macrocarpaea* sect. *Macrocarpaea* sensu Grant (2005). The only sampled species of six from the tepuis, *M. neblinae* Maguire & Steyerl. is sister to *M. gattaca* J. R. Grant from the Andes in clade III, and all Mesoamerican species are placed in clade II. Within the southern

clade, *M. arborescens* Gilg is sister to all other species, which are divided into two clades: clades V and VI. *Macrocarpaea* sect. *Magnolifoliae* is paraphyletic in the sense of Grant (2005; including the *viscosa* clade of clade VI), and clade V. Clade VI corresponds to *Macrocarpaea* sect. *Choriophylla*.

BIOGEOGRAPHIC ANALYSIS

Nodes on the selected most parsimonious tree were classified into either allopatric (nonoverlapping), partially sympatric (slightly overlapping), or sympatric (overlapping) distributions based on the extant, detailed spatial distribution of each species. Past distributions for common ancestors to extant species most likely are at least somewhat different from the current species distribution, but because such historical information is unavailable, no better estimate is possible from the current species distributions. In addition, the DIVA analysis provided hypotheses of dispersal and vicariance events that were taken into account when nodes were classified. The classification of nodes into sympatric versus allopatric species distributions resulted in six sympatric, 25 partially sympatric (– partially allopatric), and 24 allopatric nodes (Fig. 3). When this is done for the 19 species pairs in the phylogenetic tree, there are four sympatric, three partially sympatric, and 12 allopatric species pairs, given this phylogeny and species sampling. Allopatry is more common than true sympatry with a ratio of 3:1 to 4:1, but this does not account for the partially sympatric/allopatric distributions.

The DIVA analysis resulted in an exact solution during the optimization, and an optimal reconstruction for our data required a total of 29 dispersal events. Within *Macrocarpaea*, there are 17 dispersal events and six vicariance events. Ancestral area reconstructions and invoked dispersal events are shown in Figure 4.

Table 2. Morphological data matrix of 57 *Macrocarpaea* species and five outgroups from *Chorisepalum*, *Symbolanthus*, and *Tachia*.*

Taxa/character	123456789
<i>Chorisepalum psychotrioides</i>	111111000
<i>Symbolanthus jasonii</i>	00-011011
<i>Tachia grandiflora</i>	00-011100
<i>T. guianensis</i>	00-011100
<i>T. occidentalis</i>	00-012100
<i>Macrocarpaea angelliae</i>	111001000
<i>M. apparata</i>	111001000
<i>M. arborescens</i>	00-001000
<i>M. auriculata</i>	00-001000
<i>M. bangiana</i>	111001000
<i>M. bubops</i>	111001000
<i>M. chthonotropa</i>	111001000
<i>M. cinchonifolia</i>	110100000
<i>M. cochabambensis</i>	111001000
<i>M. densiflora</i>	?????1000
<i>M. dies-viridis</i>	111001000
<i>M. domingensis</i>	00-001000
<i>M. elix</i>	111001000
<i>M. ericii</i>	00-001000
<i>M. fortisiana</i>	?????0000
<i>M. gattaca</i>	00-001000
<i>M. gaudialis</i>	00-001000
<i>M. glabra</i>	00-001000
<i>M. glaziovii</i>	00-001000
<i>M. gondoloides</i>	111001000
<i>M. harlingii</i>	111000000
<i>M. innarrabilis</i>	111001000
<i>M. jactans</i>	110100000
<i>M. jensii</i>	111001000
<i>M. kuelap</i>	111001000
<i>M. lenae</i>	111001000
<i>M. luna-gentiana</i>	111001000
<i>M. luteynii</i>	111001000
<i>M. macrophylla</i>	00-001000
<i>M. maguirei</i>	110101000
<i>M. micrantha</i>	111001000
<i>M. neblinae</i>	00-001000
<i>M. nicotianifolia</i>	00-001000
<i>M. noctiluca</i>	111001000
<i>M. normae</i>	??-??0000
<i>M. obtusifolia</i>	00-001000
<i>M. opulenta</i>	111001000
<i>M. ostentans</i>	??-??0000
<i>M. pachyphylla</i>	00-001000
<i>M. pachystyla</i>	110100000
<i>M. pajonalis</i>	111001000
<i>M. papillosa</i>	00-001000
<i>M. pinetorum</i>	00-001000
<i>M. pringleana</i>	111001000
<i>M. revoluta</i>	111000000
<i>M. robin-fosteri</i>	110100000
<i>M. rubra</i>	00-001000
<i>M. sodiroana</i>	111001000
<i>M. stenophylla</i>	00-001000

Table 2. Continued.

Taxa/character	123456789
<i>M. subcaudata</i>	111001000
<i>M. subsessilis</i>	00-001000
<i>M. tahuantinsuyuana</i>	110100000
<i>M. thamnoides</i>	00-001000
<i>M. valerioi</i>	00-001000
<i>M. viscosa</i>	111001000
<i>M. weigendiorum</i>	110100000
<i>M. zophoflora</i>	?????1000

* Question marks indicate missing data, and hyphens indicate inapplicable characters. Characters and character states are: 1. Seed shape (3-dimensional): angular or spheroid (0), flattened (1). 2. Seed wings: absent (0), present (1). 3. Seed wings: 2-sided (0), perimetrical (1). 4. Seed shape (outline): square (0), long-linear (1). 5. Seed weight: < 0.1 mg/seed (0), > 0.1 mg/seed (1). 6. Pollen exine: verrucose (0), reticulate (1), smooth (2). 7. Flower position: terminal (0), axillary (1). 8. Corolla color: green, white, or yellow (0), red or purple (1). 9. Pollen aggregation: monads (0), tetrads or polyads (1).

The selected optimization (Fig. 4) shows an ancestral area for *Macrocarpaea* in southeastern Brazil (A), Cordillera Occidental in Colombia and Ecuador (F), and the Amotape–Huancabamba Zone in northern Peru and Ecuador (H). The first vicariance event lies between the Brazilian species (clade I) and Andean–Caribbean–Mesoamerican species. The major division within the Andean species into two subclades is a north-south vicariant event as well. The Caribbean species (clade IV; C) are supported as likely derived from Andean species (H). Dispersal patterns among Andean areas invoked from the DIVA analysis are outlined in Figure 1. Patterns within the northern clades (clades II and III; E, F, and G) are complicated and also involve one dispersal to and one from Mesoamerica (D), and one to the Guayana Shield (B). Vicariance and dispersal between the northern Ecuadorian and Colombian cordilleras are detected but represent only two dispersals: one from Cordillera Occidental (F) to Cordillera Central (E) and one from Cordillera Oriental (G) to Cordillera Central (E).

The Amotape–Huancabamba Zone (H) is supported as the ancestral area for the southern clade. Clade V dispersed early southward from H to central Peru (I) and later to southern Peru and Bolivia (J) twice, with one back-dispersal northward to H. A similar pattern is found in clade VI, which is largely restricted to the Amotape–Huancabamba Zone (H) and shows four dispersals southward (two both to I and J) and one back-dispersal from J to I. Northward dispersals to northern Ecuador and Colombia (E and F) from the southern clade are only found in two cases.

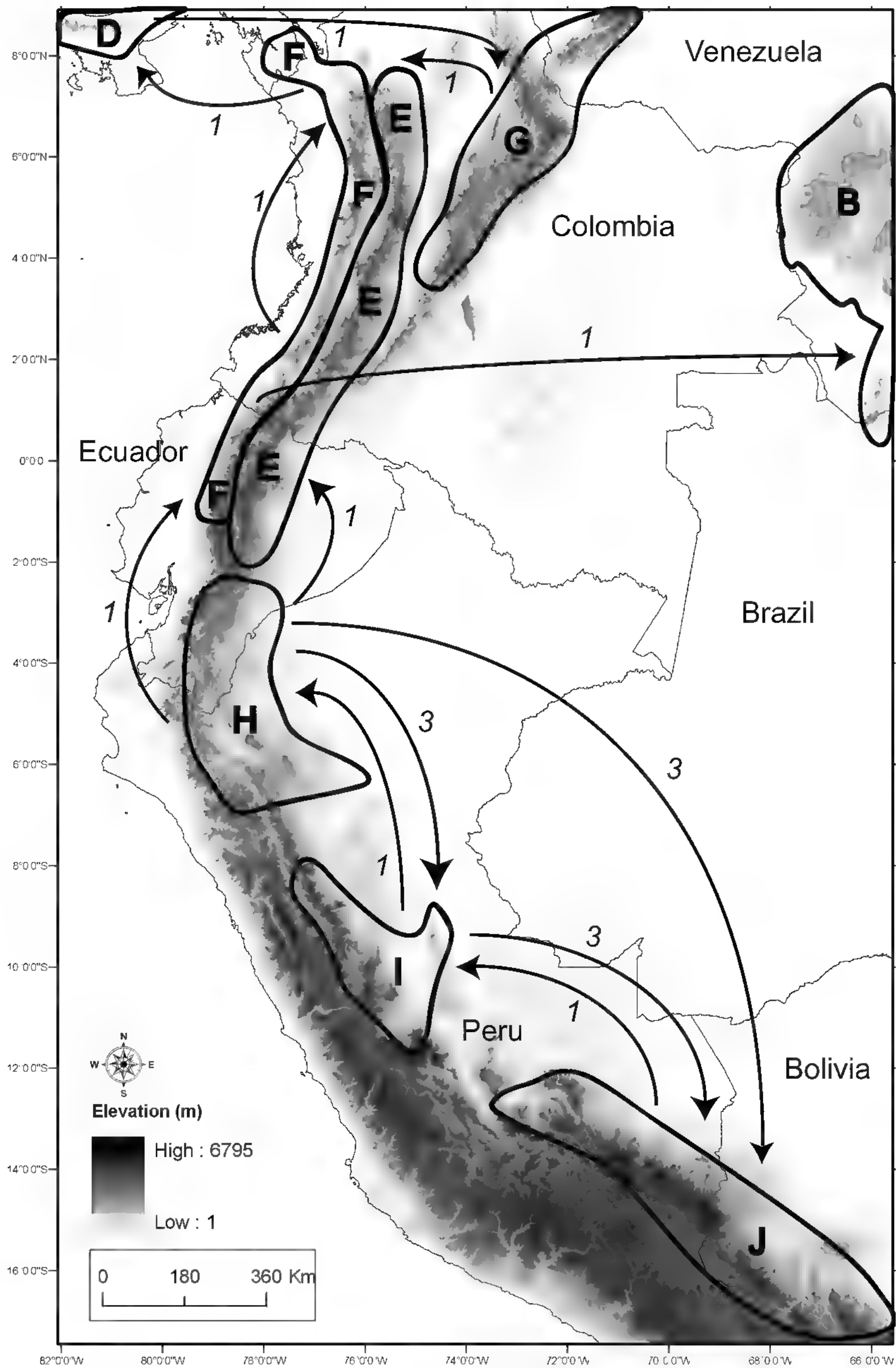

Figure 1. Map of northwestern South America and southern Mesoamerica with the areas used for biogeographic analysis identified by letters and solid lines indicating *Macrocarpaea* species distributions. Arrows with numbers indicate the number of dispersal events as hypothesized from the DIVA analysis (see Fig. 4). Biogeographic areas are: A, southeastern Brazil; B, Pantepui of the Guayana Shield; C, Greater Antilles of the Caribbean; D, Mesoamerica; E, Cordillera Central in Colombia and Cordillera Oriental in Ecuador; F, Chocó and Cordillera Occidental in Colombia and Ecuador; G, Cordillera Oriental and Mérida in Colombia and Venezuela; H, Amotape–Huancabamba region in Ecuador and Peru; I, Cordillera Central in central Peru; J, Bolivia and Cordillera Central in southern Peru; K, Amazon Basin in Brazil, Colombia, Peru, and Venezuela. Areas A, C, and K are not indicated on the map.

Table 3. Distribution data matrix used for the DIVA analysis, with 0 indicating absent and 1 present for each specific area. See further information in Materials and Methods and Figure 4 for area definitions. Taxon names marked with * represent a larger clade; see text for further explanation.

Taxon/area	ABCDEFGHIJK
<i>Chorisepalum</i>	01000000000
<i>psychotrioides</i>	
<i>Symbolanthus jasonii</i>	00000001000
<i>Tachia grandiflora</i>	01000000001
<i>T. guianensis</i>	01000000000
<i>T. occidentalis</i>	00000001111
<i>Macrocarpaea arborescens</i>	00000001000
<i>M. auriculata</i> *	00010000000
<i>M. bangiana</i>	00000000010
<i>M. chthonotropa</i> *	00000001000
<i>M. cinchonifolia</i>	00000000010
<i>M. cochabambensis</i>	00000000010
<i>M. ericii</i>	00000001000
<i>M. fortisiana</i>	00000000010
<i>M. gattaca</i>	00000100000
<i>M. gaudialis</i> *	00001000000
<i>M. glabra</i>	00000010000
<i>M. gondoloides</i> *	00000100000
<i>M. jactans</i>	00000001000
<i>M. jensii</i> *	00000001000
<i>M. luna-gentiana</i>	00000001000
<i>M. macrophylla</i>	00001100000
<i>M. maguirei</i>	00000000010
<i>M. neblinae</i>	01000000000
<i>M. nicotianifolia</i>	00000010000
<i>M. noctiluca</i> *	00000001000
<i>M. normae</i>	00000000010
<i>M. obtusifolia</i> *	10000000000
<i>M. ostentans</i>	00000000100
<i>M. pachystyla</i>	00000000100
<i>M. pajonalis</i>	00000000100
<i>M. papillosa</i>	00000010000
<i>M. pinetorum</i> *	00100000000
<i>M. pringleana</i>	00001001000
<i>M. revoluta</i>	00000000100
<i>M. robin-fosteri</i>	00000000100
<i>M. sodiroana</i>	00000100000
<i>M. subsessilis</i> *	00000001000
<i>M. tahuantinsuyuana</i>	00000000100
<i>M. valerioi</i>	00010000000
<i>M. viscosa</i>	00000000100
<i>M. weigendiorum</i>	00000000100
<i>M. zophoflora</i>	00000001000

SEEVA ANALYSIS

Nine environmental variables were analyzed for 56 nodes within *Macrocarpaea* (nodes 6 to 61 vs. the outgroup nodes 1 to 5; Fig. 3; see Table 4 for impact index and *P* values). Allopatric nodes had an average

total impact index (*i*) of 0.39 (all variables and all nodes), whereas partly sympatric nodes had an average impact index of 0.26, and sympatric nodes 0.41. The differences in impact numbers indicate some differences between the groups, but there are only slightly larger environmental differences between sister clades of sympatric nodes than between sister clades of allopatric nodes. When terminal species pairs are analyzed, the results are more pronounced. The average impact index for allopatric species pairs was 0.49 (all variables and all nodes), for partly sympatric 0.40, and for sympatric 0.41. This finding indicates that allopatric species pairs may have ecological niches more divergent from each other than both sympatric and partly allopatric species. Allopatric terminal species pairs are the more ecologically different than when allopatric nodes are compared.

Four Andean terminal sympatric species pairs were analyzed: *Macrocarpaea densiflora* (Benth.) Ewan versus *M. pachyphylla* Gilg in Cordillera Central of Colombia (Fig. 3, node 21), *M. apparata* J. R. Grant & Struwe versus *M. elix* J. R. Grant in southern Ecuador (node 37), *M. bubops* J. R. Grant & Struwe versus *M. harlingii* J. S. Pringle in southern Ecuador (node 38), and *M. dies-viridis* J. R. Grant versus *M. lenae* J. R. Grant in southern Ecuador (node 45). For node 21, only temperature seasonality showed significant differences between the two sister species (*i* = 0.54; *P* < 0.0001). Nodes 37 and 38 represent two sympatric species pairs that, in turn, are partially sympatric sister groups to each other, but the two species pairs show significant differences in what variables are different between species. Node 37 showed significant differences in all variables except precipitation seasonality, with the largest differences in soil type (*i* = 1.0; *P* < 0.001). In contrast, node 38 only shows significant differences in three variables: elevation (*i* = 0.34; *P* = 0.0037), mean annual temperature (*i* = 0.29; *P* = 0.0028), and minimum temperature of the coldest month (*i* = 0.25; *P* = 0.0047). Node 45 has five significant variables: bedrock geological age (*i* = 0.50; *P* < 0.001), temperature seasonality (*i* = 0.51; *P* < 0.001), annual precipitation (*i* = 0.58; *P* = 0.0083), precipitation of the driest month (*i* = 0.51; *P* < 0.0001), and precipitation seasonality (*i* = 0.51; *P* < 0.001). A similar lack of a general pattern is seen when allopatric or partially sympatric species pairs are analyzed (Table 4).

The environmental differences between the more strongly supported nodes are presented here (cf. Fig. 2). Clades II and III are in the northern Andes, tepuis, and Mesoamerica, and joined by node 10 (Fig. 3). SEEVA analysis of the two clades (Table 4)

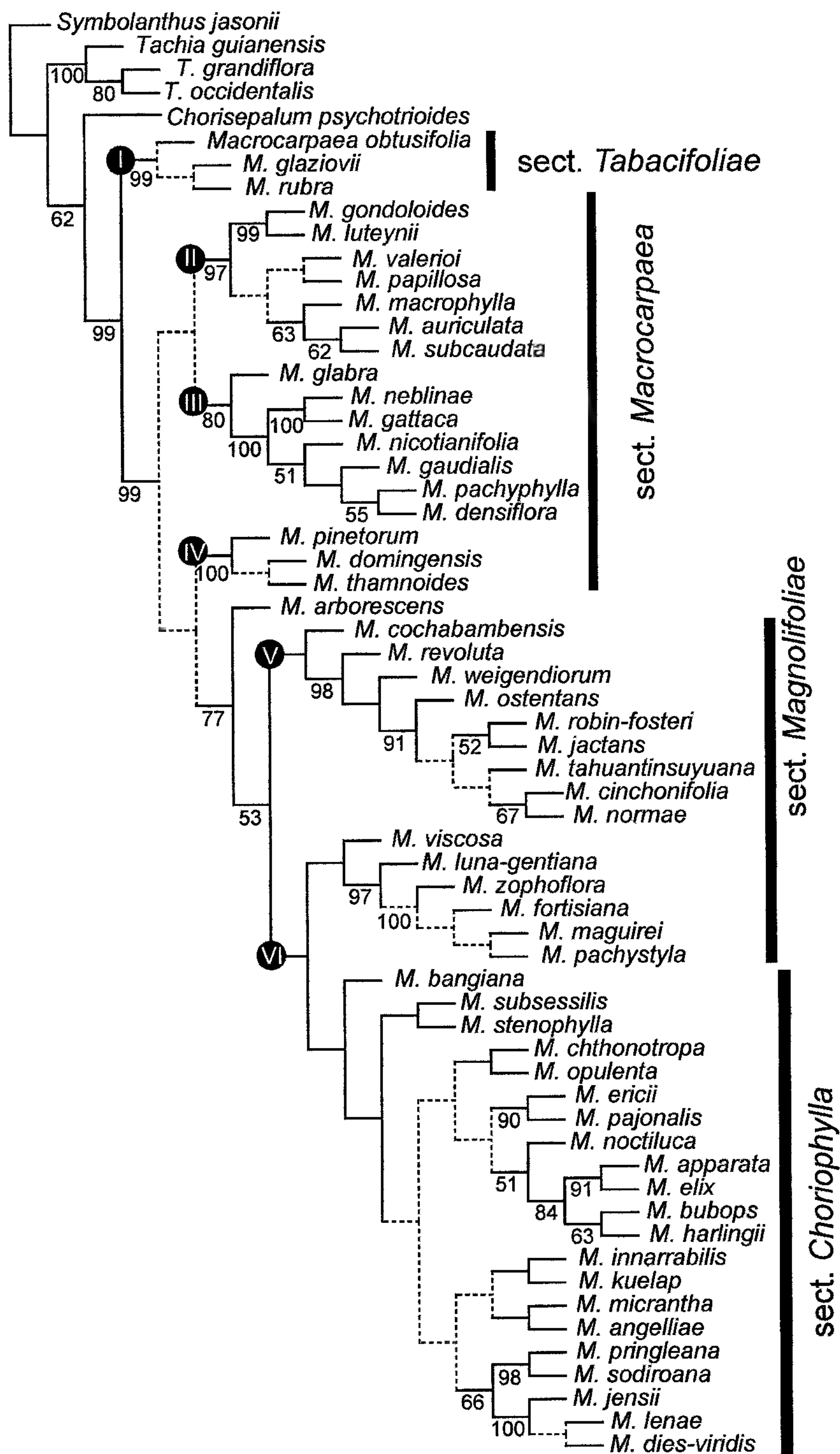

Figure 2. One of 160 most parsimonious trees from the phylogenetic analysis based on combined molecular (ITS and 5S-NTS) and morphological data. Outgroups are *Chorisepalum*, *Symbolanthus*, and *Tachia*. This tree was used in the SEEVA and DIVA analyses. Dotted branches collapse in the strict consensus tree, and numbers below branches indicate bootstrap support above 50%. Current infrageneric classification for *Macrocarpaea* is indicated on the right. Clades marked I–VI correspond to nodes discussed in the text. The northern clade includes clades II + III, and the southern clade includes *M. arborescens* plus clades V + VI.

reveals that all variables show significant differences. Impact indices above 0.40 are found for four variables: elevation, soil type, annual mean temperature, and minimum temperature of coldest month.

Node 27 (Fig. 3) divides clades V and VI from each other and represents a division between a northern (primarily area H, clade V) and southern clade (areas I + J, clade VI). Seven of nine variables show differences in ecological trends between these two clades (Table 4), and the largest impact indices (– differences) are found for temperature seasonality ($i = 0.37$) and precipitation seasonality ($i = 0.32$). Node 42 separates a clade of three southern Ecuadorian species from a clade that dispersed from this area (H) into northern Ecuador and southern Colombia (E, F, and H; *Macrocarpaea pringleana* J. R. Grant and *M. sodiroana* Gilg). This major difference in distribution is associated with significant environmental differences in six of the nine variables (67%): soil type, annual mean temperature, temperature seasonality, annual precipitation, precipitation of the driest month, and precipitation seasonality. The largest differences are found in annual precipitation ($i = 0.35$) and temperature seasonality ($i = 0.37$).

DISCUSSION

CONTINENTAL SCALE PATTERNS

Similar biogeographic patterns can often be detected in taxa of a similar age and geographic origin. For South America, there are many different groups of this kind, from the Gondwanic relicts with connections to Africa, Antarctica, and Asia more than 100 million years ago (Ma) to recent arrivals from the northern temperate zone along the Rocky Mountains of North America and the Andes when the Isthmus of Panama closed only a few million years ago. Other groups have evolved in situ on the South American continent and spread to North America, the Caribbean islands, and even farther away to New Zealand, Australia, and Africa. South America was, in effect, an isolated continent for more than 90 million years (from ca. 95 Ma, mid-Cretaceous Cenomanian, to ca. 4 Ma, Miocene; Burnham & Graham, 1999). During this time, many organismal lineages were dispersing to the South American continent, evolved in situ, and dispersed within it.

We do not know the exact age of *Macrocarpaea* or its tribe Helieae due to the lack of fossils and secure phylogenetic dating. Given the position of the tribe in the family phylogeny and an estimated age of 42–50 Ma for the whole Gentianaceae (Yuan et al., 2003), we can assume that the Helieae, and maybe the genus *Macrocarpaea* as well, has been in South America for

at least 30 million years. *Macrocarpaea* is part of one of the more basal divergences in the tribe (the *Macrocarpaea* subclade), with only the southeast Brazilian genera *Prepusa* Mart. and *Senaea* Taub. positioned below it in the phylogeny (Struwe et al., 2009). This minimum age estimate (30 Ma) needs to be tested both in a larger molecular dating analysis of the whole Gentianaceae family and in a detailed analysis of Helieae, when fossils or other additional evidence become available.

The large-scale biogeographic patterns found in *Macrocarpaea* fit a scenario that is partly consistent with the geological history of South America. The DIVA analysis maps the disjunct areas (A, F, and H; Fig. 4) at the base of *Macrocarpaea*, supporting a disjunct ancestral area for the genus including the mountains of southeastern Brazil and northern Peru, Ecuador, and Colombia. It is too early to tell whether this disjunct area distribution is due to an ancient dispersal, or extinction in the in-between areas. The sister genus (*Tachia*) occurs in the connecting Amazon Basin area and is absent from southeastern Brazil, and therefore provides some support for a broad distribution of a common ancestor of *Tachia* and *Macrocarpaea*. An ancient dispersal event from an ancestor restricted to southeastern Brazil to the Andes is not strongly supported, because our DIVA result strongly supports the inclusion of the northern Andean areas in the ancestral area for *Macrocarpaea*. The supported scenario does not include the Bolivian Andes as a dispersal corridor northward from Brazil.

The first divergence in *Macrocarpaea* is between the three species in the coastal Atlantic forest of southeastern Brazil, an area known for its high biodiversity (Myers et al., 2000), and all other species in the genus (Andes, tepuis, Mesoamerica, and the Greater Antilles). Southeastern Brazil is part of the ancient Gondwanic crust in South America, together with the Guayana Shield, and these areas represent relatively long-term geological stability, with the lack of historical sea incursions (Clapperton, 1993). Southeastern Brazil has repeatedly been shown to include relictual, ancestrally placed lineages of gentians, not only in *Macrocarpaea* and Helieae, but also in Saccifolieae and Chironieae subtribe Coutoubeinae (Struwe et al., 2002). This southeastern Brazil–Andean pattern, with the Brazilian area being more ancestral, has also been found in other groups that show a large divergence in Neotropical forests (e.g., *Fuchsia* L. [Berry et al., 2004] and Gesneriaceae tribe Sinningieae [Perret et al., 2003, 2007]).

Several hypotheses have been proposed for the derivation of the tepui flora on the Guayana Shield, representing long-distance dispersal from the Andes, derivation from lowland white-sand areas (Kubitzki,

1989), and in situ relictual lineages (Maguire, 1970). Support for several of these hypotheses is found within the Helieae and related tribes, with some genera (e.g., *Potalia* Aubl.) supporting the lowland to highland theory (Struwe et al., 2002; Frasier et al., 2008).

The derivation of Mesoamerican species (*Macrocarpaea auriculata* Weaver & J. R. Grant, *M. subcaudata* Ewan, and *M. valerioi* Standl.) from two lineages in the Colombian Andes is a common pattern in many plant groups and is likely due to dispersal northward along the Isthmus of Panama after its closing 3.1 Ma (Burnham & Graham, 1999). During the American interchange, many organismal groups moved either north or south, and other gentians that show a southern derivation include *Potalia* (Frasier et al., 2008) and *Tachia* (Struwe, unpublished data). According to preliminary data from DIVA-GIS analysis of available ecological niches (Struwe, pers. comm.), there are suitable habitats for *Macrocarpaea* north of Costa Rica, but these have not evidently been inhabited yet.

Three species of *Macrocarpaea* occur on the islands of the Greater Antilles: *M. domingensis* Urb. & Ekman (Hispaniola), *M. pinetorum* Alain (Cuba), and *M. thamnoides* (Griseb.) Gilg (Jamaica), and are included in this study. Their biogeographic relationships are still uncertain because their position as being derived from an Andean ancestor has poor branch support in the phylogenetic tree, but they are strongly supported as being closer to Andean lineages than to the Brazilian lineage or Central American species. Long-distance dispersal from the northern Andes to the Caribbean is the most likely scenario. Based on the location of the Caribbean clade in the phylogenetic result, this did not happen relatively recently. The ancestor of the *Macrocarpaea* species that occurs in the Greater Antilles did not have wind-dispersed seeds, so it was most likely dispersed inadvertently by birds. Similar long-distance dispersal patterns between the Andes and Hispaniola have been found earlier in *Fuchsia* (Berry, 1982, 2004). The Caribbean area is a complex region of several different origins, and its general biogeography and geological history are under debate and still not fully understood (Iturralde-Vinent & MacPhee, 1999). Cuba and Hispaniola are older than Jamaica, and they were connected during the early Oligocene (Iturralde-Vinent & MacPhee, 1999), but this was most likely long before the arrival of *Macrocarpaea* on these islands.

ANDEAN PATTERNS

The Andean uplift started in the Miocene (ca. 20 Ma) and continued until the Holocene, generally

moving from the southern part of the mountain range toward the northern part, with the main northern upheaval ca. 2–8 Ma (Haffer, 1987). Other scientists support an earlier start at 40 Ma, with major northern uplift at 18 Ma, as suggested by Ghosh et al. (2006) and Gregory-Wodzicki (2000). The Andean forests of the northern Andes where *Macrocarpaea* occurs have been hypothesized to be of Miocene to lower Pliocene in age (van der Hammen, 1979), but their range in elevation shifted downward during the Pleistocene glaciations (Haffer, 1987). The Andean clade of *Macrocarpaea* is clearly separated into two subclades, a northern and southern one, divided at the Amotape–Huancabamba Zone. The geographic division of these two groups follows the Amotape Cross, a geological shear zone, which divides the Andes (and Ecuador) into two parts: the younger northern Andes (formed in Late Pliocene to Pleistocene) and older central Andes (Miocene to Pliocene; Young & Reynel, 1997).

Based on our DIVA analysis, the ancestral distribution within the Andes includes the Amotape–Huancabamba Zone (H), which is among the most species-rich areas in the Andes. Also included in the ancestral Andean area are the Cordillera Occidental of Colombia and Ecuador (F) and the Cordillera Oriental of Colombia and Cordillera de Mérida in Venezuela (G). The deep split between the northern and southern clades of *Macrocarpaea* represents an ancient divergence that strongly correlates with current distribution patterns. The fact that only two dispersal events have crossed over from the south to the north, and none from the north to the south, is remarkable. This zone in central and northern Ecuador is also known for its absence of *Tachia* and *Symbolanthus*, two other Helieae genera that have suitable habitats in the boundary area. Possible explanations for this deep divide might be the early division of the Andes in this region between a northern and southern part, since they have been divided by sea incursions (early Miocene), mountain uplift and creation of valleys, and/or volcanism (Clapperton, 1993; Burnham & Graham, 1999), or perhaps a westward flow of the Amazon into the Pacific Ocean (Mapes et al., 2006).

Quaternary volcanism is absent from the Amotape–Huancabamba Zone (area H) and the central Peruvian area (H and I), but occurs in areas both north and south of these regions (Clapperton, 1993). Volcanism could affect extinction rates severely, and the lack of volcanism might partly explain the relatively higher species numbers in the Amotape–Huancabamba Zone. In addition, this area is characterized by humid isolated forest islands occurring in a highly dissected landscape (Jørgensen, pers. comm.). The species of the southern clade also have wind-dispersed, winged

Table 4. Results from SEEVA analysis of Neotropical *Macrocarpaea* data showing impact index (*i*) and *P* values for each node in the phylogeny. Node numbers and tree topology correspond to Figure 3. Nine variables were analyzed. Column SP marks terminal species pairs with a Y for presence. Column D classifies all nodes into allopatric (A), partially sympatric (PS), or sympatric (S), following results in Figure 3. Please see text for further explanations. Impact index in boldface numbers indicates $i > 0.5$, and statistically significant differences are indicated by *P* values ($P < 0.05$) in boldface. For empty cells, there was no difference in environmental categories between species so the analysis could not be run.

Node	SP	D	Elevation		Soil type		Geology (age)		Annual mean temperature		Temperature seasonality		Minimum temperature coldest month		Annual precipitation		Precipitation of driest month		Precipitation seasonality	
			<i>i</i>	<i>P</i>	<i>i</i>	<i>P</i>	<i>i</i>	<i>P</i>	<i>i</i>	<i>P</i>	<i>i</i>	<i>P</i>	<i>i</i>	<i>P</i>	<i>i</i>	<i>P</i>	<i>i</i>	<i>P</i>	<i>i</i>	<i>P</i>
6	-	A	0.30	0.0000	0.18	0.0000	0.25	0.0000	0.18	0.0000	0.38	0.0000	0.12	0.0000	0.27	0.0000	0.17	0.0000	0.08	0.0013
7	-	PS	0.23	0.0417	0.57	0.0000	0.20	0.0145	0.19	0.0062	-	-	0.29	0.0000	0.20	0.0138	0.37	0.0000	0.28	0.0000
8	Y	PS	0.19	0.1694	-	-	0.41	0.0000	0.25	0.0051	-	-	0.23	0.0015	0.37	0.0000	0.32	0.0000	0.37	0.0000
9	-	PS	0.11	0.0000	0.32	0.0000	0.19	0.0000	0.15	0.0000	0.19	0.0000	0.09	0.0005	0.19	0.0000	0.04	0.4049	0.17	0.0000
10	-	PS	0.43	0.0000	0.44	0.0000	0.23	0.0000	0.43	0.0000	0.36	0.0000	0.45	0.0000	0.37	0.0000	0.26	0.0000	0.25	0.0000
11	-	A	0.06	0.9099	0.09	0.5672	0.42	0.0038	0.15	0.0944	0.33	0.0000	0.11	0.3123	0.16	0.0366	0.09	0.4650	0.25	0.0002
12	Y	A	0.37	0.0000	0.52	0.0000	-	-	0.45	0.2424	-	-	0.45	0.2424	0.60	0.0022	0.71	0.0000	0.71	0.0000
13	-	A	0.23	0.0003	0.18	0.0137	0.04	1.0000	0.22	0.0008	0.44	0.0000	0.23	0.0003	0.19	0.0032	0.14	0.0969	0.33	0.0000
14	-	A	0.27	0.0078	0.27	0.0090	-	-	0.22	0.0506	0.46	0.0000	0.20	0.0966	0.29	0.0084	0.11	0.5171	0.38	0.0000
15	Y	PS	0.42	0.0549	0.78	0.0000	-	-	0.36	0.1765	0.35	0.0916	0.36	0.1765	0.18	1.0000	0.42	0.0067	0.38	0.0595
16	Y	A	0.16	0.2933	0.71	0.0000	-	-	0.15	0.2554	0.36	0.0000	0.18	0.1842	0.54	0.0000	0.33	0.0000	0.21	0.0836
17	-	PS	0.05	0.6985	0.31	0.0000	0.29	0.0000	0.35	0.0000	0.19	0.0090	0.22	0.0001	0.45	0.0000	0.47	0.0000	0.47	0.0000
18	-	A	0.37	0.0005	0.25	0.0555	0.53	0.0000	0.49	0.0000	0.35	0.0033	0.33	0.0002	0.45	0.0000	0.24	0.0309	0.30	0.0015
19	-	A	0.28	0.1173	0.32	0.0762	0.35	0.0385	0.48	0.0046	0.03	1.0000	0.41	0.0007	0.44	0.0003	0.45	0.0002	0.47	0.0008
20	-	A	0.33	0.1633	0.47	0.0115	0.56	0.0152	0.33	0.1633	0.54	0.0024	0.28	0.1950	0.22	0.4987	0.25	0.3109	0.12	1.0000
21	Y	S	0.40	0.2536	0.10	1.0000	0.37	0.2500	0.40	0.2536	0.54	0.0000	0.41	0.1946	0.23	1.0000	0.26	0.3839	0.40	0.0964
22	Y	A	0.49	0.1053	1.00	0.0000	1.00	0.0000	0.08	1.0000	0.15	1.0000	0.12	1.0000	0.71	0.0000	1.00	0.0000	1.00	0.0000
23	-	A	0.22	0.0000	0.12	0.0004	-	-	0.20	0.0000	0.30	0.0000	0.16	0.0000	0.14	0.0000	0.12	0.0001	0.12	0.0000
24	-	A	0.44	0.0237	-	-	-	-	0.31	0.0360	-	-	0.34	0.0411	0.41	0.0034	0.36	0.0157	0.29	0.0960
25	Y	A	0.06	1.0000	-	-	-	-	0.34	0.2001	-	-	0.38	0.1370	0.54	0.0010	0.51	0.0034	0.34	0.0651
26	-	PS	0.20	0.0000	0.21	0.0000	0.04	0.7296	0.23	0.0000	0.13	0.0000	0.13	0.0000	0.20	0.0000	0.14	0.0000	0.15	0.0000
27	-	PS	0.09	0.0277	0.14	0.0000	0.06	0.3441	0.05	0.4024	0.37	0.0000	0.16	0.0000	0.10	0.0048	0.29	0.0000	0.32	0.0000
28	-	PS	0.19	0.0000	0.10	0.0193	0.10	0.0369	0.16	0.0001	0.17	0.0002	0.22	0.0000	0.14	0.0005	0.13	0.0004	0.16	0.0000
29	-	A	0.02	1.0000	0.05	0.5973	0.10	0.0199	0.05	0.5102	0.36	0.0000	0.10	0.0023	0.07	0.2762	0.19	0.0000	0.19	0.0000
30	-	PS	0.23	0.0000	0.27	0.0000	0.16	0.0001	0.18	0.0000	0.21	0.0000	0.22	0.0000	0.18	0.0000	0.26	0.0000	0.24	0.0000
31	Y	A	0.31	0.2805	0.71	0.0000	1.00	0.0000	0.50	0.0335	1.00	0.0000	0.52	0.0003	0.52	0.0000	0.13	0.4885	0.52	0.0000
32	-	PS	0.15	0.0004	0.18	0.0000	0.18	0.0000	0.21	0.0000	0.12	0.0043	0.22	0.0000	0.25	0.0000	0.19	0.0000	0.16	0.0001
33	-	PS	0.16	0.0019	0.10	0.2350	0.15	0.0276	0.12	0.0714	0.18	0.0060	0.09	0.2485	0.18	0.0075	0.09	0.0681	0.14	0.0503
34	-	PS	0.07	0.6129	0.14	0.0450	0.21	0.0001	0.05	0.8275	0.33	0.0000	0.20	0.0009	0.13	0.0715	0.31	0.0000	0.32	0.0000

Table 4. Continued.

Node	SP	Elevation		Soil type		Geology (age)		Annual mean temperature		Temperature seasonality		Minimum temperature coldest month		Annual precipitation		Precipitation of driest month		Precipitation seasonality		
		D	i	P	i	P	i	P	i	P	i	P	i	P	i	P	i	P	i	P
35	-	S	0.40	0.0000	0.34	0.0000	0.21	0.0009	0.32	0.0000	0.33	0.0000	0.32	0.0000	0.32	0.0000	0.33	0.0000	0.43	0.0000
36	-	PS	0.25	0.0180	0.39	0.0000	0.32	0.0002	0.43	0.0000	0.50	0.0000	0.46	0.0000	0.25	0.0191	0.54	0.0000	0.41	0.0000
37	Y	S	0.58	0.0000	1.00	0.0000	0.66	0.0000	0.71	0.0000	0.71	0.0000	0.71	0.0000	0.53	0.0000	0.58	0.0278	0.48	0.0556
38	Y	S	0.34	0.0037	0.10	1.0000	0.19	0.2095	0.29	0.0028	0.16	0.3057	0.25	0.0447	0.16	0.2331	0.27	0.0845	0.05	1.0000
39	Y	A	0.23	0.3982	0.89	0.0000	0.77	0.0000	0.16	0.8063	0.46	0.0045	0.36	0.0086	0.31	0.1003	0.63	0.0000	0.58	0.0000
40	Y	A	0.71	0.0000	0.50	0.4667	-	-	0.71	0.0000	-	-	0.71	0.0000	0.71	0.0000	0.71	0.0000	1.00	0.0000
41	-	PS	0.18	0.0038	0.32	0.0000	0.15	0.0299	0.28	0.0000	0.32	0.0000	0.21	0.0004	0.29	0.0000	0.18	0.0043	0.24	0.0000
42	-	PS	0.18	0.0643	0.33	0.0000	0.15	0.2160	0.22	0.0066	0.37	0.0000	0.07	0.7910	0.35	0.0002	0.26	0.0010	0.25	0.0018
43	Y	A	0.24	0.0351	0.36	0.0009	0.21	0.0757	0.13	0.4644	0.57	0.0000	0.17	0.2079	0.43	0.0000	0.40	0.0000	0.51	0.0000
44	Y	S	0.56	0.0020	0.18	0.7771	0.67	0.0152	0.58	0.0001	0.69	0.0055	0.52	0.0054	0.50	0.0104	0.69	0.0055	0.23	0.0000
45	Y	S	0.38	0.3000	0.22	1.0000	0.50	0.0000	0.42	0.1833	0.51	0.0000	0.22	1.0000	0.58	0.0083	0.51	0.0000	0.51	0.0000
46	-	PS	0.28	0.0018	0.12	0.4283	0.33	0.0008	0.35	0.0000	0.12	0.5047	0.40	0.0000	0.37	0.0000	0.40	0.0000	0.44	0.0000
47	Y	A	0.47	0.0007	0.50	0.0022	-	-	0.58	0.0000	0.15	0.6396	0.71	0.0000	0.58	0.0000	0.71	0.0000	0.59	0.0000
48	Y	PS	0.45	0.0001	0.39	0.0058	0.62	0.0000	0.46	0.0000	0.46	0.0000	0.44	0.0000	0.37	0.0024	0.50	0.0003	0.70	0.0000
49	-	PS	0.11	1.0000	0.33	0.0754	-	-	0.11	1.0000	0.33	0.0410	0.23	0.4001	0.15	0.8458	0.35	0.0296	0.32	0.0429
50	-	A	0.45	0.0000	0.64	0.0000	1.00	0.0000	0.46	0.0011	0.52	0.0002	0.31	0.1641	0.32	0.1183	0.47	0.0006	0.47	0.0015
51	-	A	0.28	0.0000	0.19	1.0000	-	-	0.58	0.0000	0.47	0.1111	0.18	1.0000	0.38	0.1111	0.47	0.0000	0.47	0.1111
52	-	PS	0.53	0.0357	1.00	0.0000	-	-	0.32	1.0000	0.24	1.0000	0.32	1.0000	0.43	0.0357	0.32	1.0000	0.24	1.0000
53	Y	A	0.71	0.0000	-	-	-	-	0.71	0.0000	0.71	0.0000	0.71	0.0000	0.58	0.0000	0.71	0.0000	0.71	0.0000
54	-	PS	0.19	0.0951	0.14	0.4283	0.29	0.0051	0.14	0.3862	0.16	0.2528	0.16	0.2955	0.19	0.1252	0.13	0.8694	0.14	0.4430
55	-	PS	0.14	0.6036	0.25	0.1683	0.14	0.6701	0.20	0.0457	0.26	0.0263	0.15	0.3565	0.14	0.5626	0.10	0.5129	0.10	0.6455
56	-	PS	0.19	0.0000	0.11	1.0000	0.40	0.0000	0.20	0.0732	0.58	0.0000	0.22	0.0000	0.28	0.0000	0.32	0.0000	0.27	0.0244
57	-	PS	0.16	0.2065	-	-	0.15	0.6507	0.15	0.5062	0.44	0.0038	0.24	0.0148	0.31	0.0113	0.49	0.0000	0.53	0.0000
58	-	PS	0.21	0.2203	0.48	0.0058	0.40	0.0002	0.14	0.7373	0.32	0.0140	0.05	1.0000	0.29	0.0259	0.24	0.0266	0.29	0.0000
59	Y	A	0.15	1.0000	-	-	0.09	1.0000	0.26	0.1538	0.48	0.0000	0.39	0.0769	0.37	0.0000	0.39	0.1538	0.71	0.0000
60	-	A	0.24	0.3271	0.50	0.0396	0.36	0.0058	0.13	1.0000	0.41	0.0000	0.19	0.6764	0.25	0.3027	0.11	1.0000	-	-
61	Y	A	0.33	0.1292	0.54	0.0441	0.59	0.0000	0.37	0.0691	-	-	0.33	0.1292	0.29	0.2862	0.14	1.0000	-	-

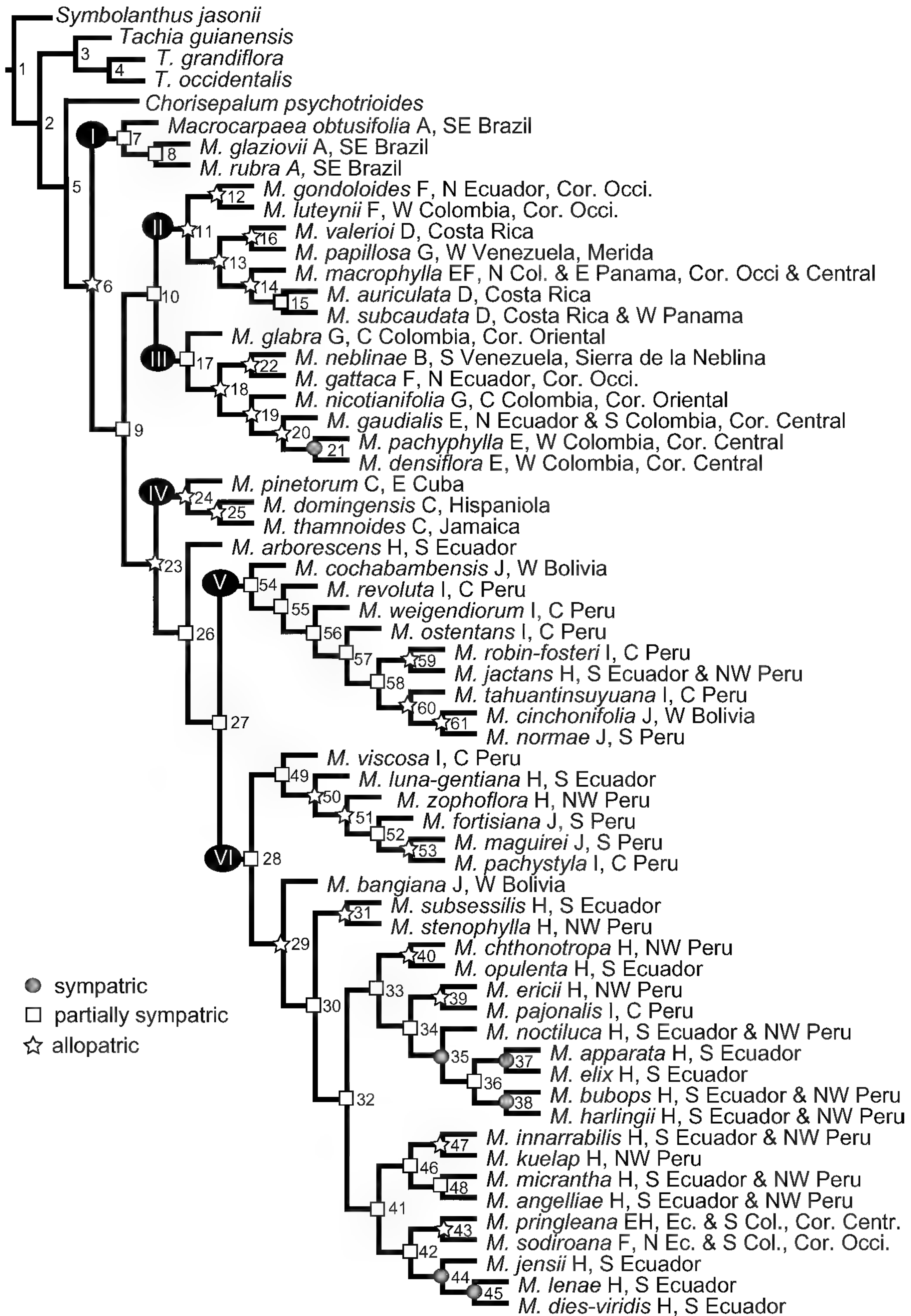

Figure 3. The selected most parsimonious tree used in DIVA and SEEVA analyses, with numbered nodes and geographic distribution listed for each species. Biogeographic area coding for DIVA is indicated with letters A–K after species names (see text for definition of areas). Symbols (●, □, ☆) on nodes indicate sympatric, partially sympatric, or allopatric clades, based on exact species distribution within *Macrocarpaea* (not DIVA area classification), which is further analyzed in the SEEVA analysis.

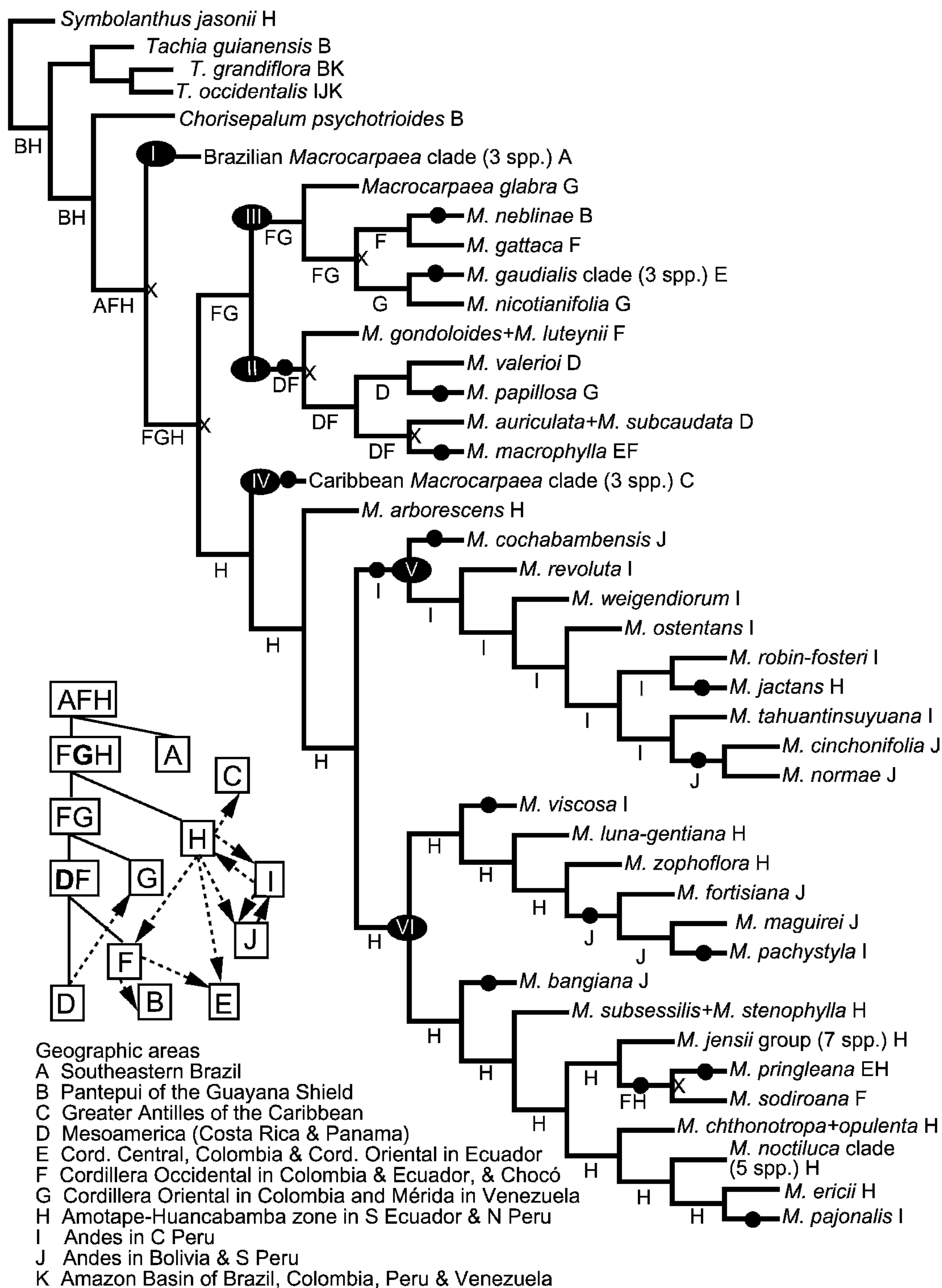

Figure 4. Results of the DIVA analysis when mapped onto the selected most parsimonious phylogenetic tree. Areas optimized onto each branch are marked with letters (see legend and Fig. 3 for coding); when several optimizations were equally optimal, one was selected based on spatial and geological information (see Appendix 1 for all optimal DIVA reconstructions). Circles (●) on branches indicate dispersal events leading to speciation or enlargement of geographic distribution for a species, and × by a node indicates a vicariance event leading to speciation. The schematic diagram to the left shows an overview of area relationships, with bold letters (D, G) indicating expansion to new areas, solid lines indicating vicariance events, and arrows indicating dispersal events. Vicariations and dispersals are only marked for *Macrocarpaea*.

seeds that presumably could lead to increased colonization of new areas and thereby increased allopatric speciation through island hopping. However, more instances of allopatric speciation are found in the northern clade than in the southern clade. Weigend (2002, 2004) showed that the Huancabamba depression is not a dispersal barrier to Andean species of middle elevations, and this conclusion is upheld by our data. This finding is in contrast to data from *Eleutherodactylus* Duméril & Bibron frogs (Young & Reynel, 1997; Duellman & Pramuk, 1999); however, it should be noted that this vertebrate group represents an immense Neotropical radiation with a very different speciation history.

SPECIATION PATTERNS

Within Andean *Macrocarpaea*, allopatric speciation is much more common than sympatric speciation, and this has also been shown for Gesneriaceae in southeastern Brazil (Perret et al., 2007). In some cases, allopatric speciation is linked to long-distance dispersal (e.g., *M. neblinae* on Sierra de Neblina in southern Venezuela, and *M. valerioi* in Costa Rica), but often allopatric sister taxa occur in more adjacent parts of the same mountain range (e.g., *M. cinchonifolia* (Gilg) Weaver in western Bolivia and *M. normae* J. R. Grant in southern Peru). Such north-south patterns are common and indicate either dispersals along mountain ridges or historical splitting of larger ancestral populations into separate species after isolation. Both scenarios support the theory that mountain ranges such as the Andes represent virtual islands (Young et al., 2002). In the case of *Macrocarpaea*, most species occur on the slopes and not on the summits, but slopes may serve as isolated units as well. Isolated páramos on Andean summits have long been considered analogs to island chains such as Hawaii and the Galápagos (Young et al., 2002), but our data also support this for lower elevations. Many of the páramo plants are relatively recent immigrants from plant groups from the northern temperate zones, whereas the forested slopes include primarily Neotropical floristic elements that reach high species diversity in the Andes. Within Helieae, the highest species diversity is found in the Andes, but is largely represented by only two genera, *Macrocarpaea* and *Symbolanthus* (Molina & Struwe, 2008). The Amazon lowlands and the Brazilian and Guayana Shields have much fewer species, but they represent the ancestral evolutionary lineages (Struwe et al., 2002, 2009).

The seeds of *Macrocarpaea* can be divided into two major types: very small and winged or larger, angular, and heavier. Winged seeds, which promote dispersal

over larger distances, are found in clades V and VI, which show repeated dispersal patterns north-south within the southern clade. Such seeds are also found in the northern group at node 12 (Fig. 3), *M. gondolooides* J. R. Grant and *M. luteynii* J. R. Grant & Struwe, as an independently derived character trait. The northern group with heavier seeds shows fewer occasions of dispersal, but is also more poorly sampled. Because it was not possible to include all species in our study due to unavailability of material, species from the southern area are overrepresented.

Pollinator information for *Macrocarpaea* species is relatively scarce, but most species appear to be generalists and are pollinated by a multitude of animal groups and species (Grant, pers. obs.). Pollinator segregation therefore does not support sympatric speciation in *Macrocarpaea*, and it is more likely that ecological niche divergence or population isolation and subsequent fixation of different traits in smaller populations have led to different species.

ECOLOGICAL NICHE PATTERNS

Results from the SEEVA analysis of sister species show that all species pairs have individual divergence patterns and environmental differences. Divergence in ecological niches is common both in allopatric and sympatric species in *Macrocarpaea*, and generally these divergences are not significantly different in size between the two speciation types, but these variables differ between species pairs. For example, divergences were found based on different altitudinal zones (*M. apparata* and *M. elix*; node 37, Fig. 3) and on different types of bedrock and in zones with different climate seasonality (*M. dies-viridis* and *M. lenae*; node 45, Fig. 3). Perret et al. (2007) also found a lack of increased divergence in sympatric species when compared with allopatric species.

The species differences found with SEEVA show only patterns, not processes, and variables should not be seen as the probable cause for speciation, unless further studies can show adaptation to specific environments or changes linked to paleoclimatological or geological events. We know that species have moved around on a geographic scale, especially during the Pleistocene, but their ecological niches might have been more stable due to niche conservatism. Using a different approach, Peterson et al. (1999) showed that speciation through geographic separation often appears before ecological niche separation in vertebrates and butterflies in Mexico, and our results indicate the same. Extracting environmental data from current locations therefore most likely represents historical ecological niches, if not the historical location of the population.

In future studies, it would be interesting to compare species pairs for particular areas from many different genera to determine whether ancestral populations reacted similarly to climatological and geological events in the past, and whether recurrent ecological niche divergence appeared in unrelated lineages. This would be possible, for example, in the Amotape–Huancabamba Zone, where we now have at least four different data sets from angiosperms (including the studies by Weigend, 2002, 2004).

Our study shows that explanations of speciation events need to be sought individually for each species pair, and that generalities are not necessarily applicable across a larger species group distributed over a large area. If we want to understand speciation patterns, the ecological niches of species, and threats and means to the conservation of these species, much more data need to be collected and analyzed (Young et al., 2002). One major difficulty is the lack of up-to-date revisionary, phylogenetic, and georeferenced data for most plant genera. Species-level phylogenies only represent a small percentage of Neotropical biodiversity, and there is a dire need for more taxonomic work that can be integrated with biogeography, ecology, and conservation.

Literature Cited

- Berry, P. E. 1982. The systematics and evolution of *Fuchsia* section *Fuchsia* (Onagraceae). *Ann. Missouri Bot. Gard.* 69: 1–198.
- , W. J. Hahn, K. J. Sytsma, J. C. Hall & A. Mast. 2004. Phylogenetic relationships and biogeography of *Fuchsia* (Onagraceae) based on noncoding nuclear and chloroplast DNA data. *Amer. J. Bot.* 91: 601–614.
- Burnham, R. J. & A. Graham. 1999. The history of neotropical vegetation: New developments and status. *Ann. Missouri Bot. Gard.* 86: 546–589.
- Carlquist, S. & J. R. Grant. 2005. Wood anatomy of Gentianaceae, tribe Helieae: Diversification in relation to ecology, habit, and systematics; the effect of sample diameter. *Brittonia* 57: 276–291.
- Clapperton, C. 1993. Quaternary Geology and Geomorphology of South America. Elsevier, Amsterdam.
- Duellman, W. E. & J. B. Pramuk. 1999. Frogs of the genus *Eleutherodactylus* (Anura: Leptodactylidae) in the Andes of northern Peru. *Sci. Pap. Nat. Hist. Mus. Univ. Kansas* 13: 1–78.
- Frasier, C., V. A. Albert & L. Struwe. 2008. Amazonian lowland, white sand areas as ancestral regions for South American biodiversity: Biogeographic and phylogenetic patterns in *Potalia* (Gentianaceae). *Organisms Diversity Evol.* 8: 44–57.
- Ghosh, P., C. N. Garzione & J. M. Eiler. 2006. Rapid uplift of the Altiplano revealed through C-O bonds in paleosol carbonates. *Science* 311: 511–515.
- Goloboff, P. 1999. NONA (NO NAME) ver. 2. Published by the author, Tucumán, Argentina.
- Gould, K. R. & L. Struwe. 2004. Phylogeny and evolution of *Symbolanthus* and *Wurdackanthus* (Gentianaceae-Helieae) in the Guayana Highlands and Andes, based on ribosomal 5S-NTS sequences. *Ann. Missouri Bot. Gard.* 91: 438–446.
- Grant, J. R. 2003. De Macrocarpaeae Grisebach (ex Gentianaceis) speciebus novis II: Typification of the Ruiz & Pavon names. *Harvard Pap. Bot.* 7(2): 423–436.
- . 2004. De Macrocarpaeae Grisebach (ex Gentianaceis) speciebus novis V: Twenty-three new species largely from Peru, and typification of all species in the genus. *Harvard Pap. Bot.* 9(1): 11–49.
- . 2005. De Macrocarpaeae Grisebach (ex Gentianaceis) speciebus novis VI: Seed morphology, palynology, an infrageneric classification, and another twenty-three new species, largely from Colombia. *Harvard Pap. Bot.* 9(2): 305–342.
- . 2007. De Macrocarpaeae Grisebach (ex Gentianaceis) speciebus novis VII: Four new species and two natural hybrids. *Harvard Pap. Bot.* 11(2): 129–139.
- . 2008. De Macrocarpaeae Grisebach (ex Gentianaceis) speciebus novis VIII: Two new species from Ecuador. *Harvard Pap. Bot.* 13(2): 253–259.
- & L. Struwe. 2001. De Macrocarpaeae Grisebach (ex Gentianaceis) speciebus novis I: An introduction to the genus *Macrocarpaea* and three new species from Colombia, Ecuador, and Guyana. *Harvard Pap. Bot.* 5: 489–498.
- & ———. 2003. De Macrocarpaeae Grisebach (ex Gentianaceis) speciebus novis III: Six new species of moon-gentians (*Macrocarpaea*, Gentianaceae: Helieae) from Parque Nacional Podocarpus, Ecuador. *Harvard Pap. Bot.* 8(1): 61–81.
- & R. E. Weaver Jr. 2003. De Macrocarpaeae Grisebach (ex Gentianaceis) speciebus novis IV: Eleven new species of *Macrocarpaea* (Gentianaceae: Helieae) from Central and South America, and the first report of the presence of stipules in the family. *Harvard Pap. Bot.* 8(1): 83–109.
- , P. J. M. Maas & L. Struwe. 2006. *Yanomamua araca* (Gentianaceae), a new genus and species from Serra do Aracá, an outlier of the Guayana Region in Amazonas, Brazil. *Harvard Pap. Bot.* 11(1): 29–37.
- Gregory-Wodzicki, K. M. 2000. Uplift history of the Central and Northern Andes: A review. *Bull. Geol. Soc. Amer.* 112(7): 1091–1105.
- Haffer, J. 1987. Quaternary history of tropical America. Pp. 1–18 in T. C. C. Whitmore & G. T. Prance (editors), *Biogeography and Quaternary History in Tropical America*. Clarendon Press, Oxford.
- Heiberg, E. 2008. SEEVA. Software for Spatial Evolutionary and Ecological Vicariance Analysis, ver. 0.4. Lund University, Lund, Sweden. <<http://seeva.heiberg.se>>, accessed 1 November 2008.
- & L. Struwe. 2008. SEEVA Manual. Rutgers University, Newark, New Jersey. <<http://seeva.heiberg.se>> and <<http://www.rci.rutgers.edu/~struwe/seeva>>, accessed 21 November 2008.
- Hijmans, R. J., S. E. Cameron, J. L. Parra, P. G. Jones & A. Jarvis. 2005. Very high resolution interpolated climate surfaces for global land areas. *Int. J. Climatol.* 25: 1965–1978.
- Iturralde-Vinent, M. A. & R. D. E. MacPhee. 1999. Paleogeography of the Caribbean region: Implications for Cenozoic biogeography. *Bull. Amer. Mus. Nat. Hist.* 238: 1–95.
- Jørgensen, P. M., C. Ulloa Ulloa & C. Maldonado. 2007. Riqueza de plantas vasculares. Pp. 37–50 in R. M. Moraes, B. Øllgaard, L. P. Kvist, F. Borchsenius & H. Balslev (editors), *Botánica Económica de los Andes Centrales*. Universidad Mayor de San Andrés, La Paz.

- Kubitzki, K. 1989. The ecogeographical differentiation of Amazonian inundation forests. *Pl. Syst. Evol.* 162: 285–304.
- Maguire, B. 1970. On the flora of the Guayana Highland. *Biotropica* 2: 85–100.
- Mapes, R. W., A. C. R. Nogueira, D. S. Coleman & A. M. Leguizamon Vega. 2006. Evidence for a continent scale drainage inversion in the Amazon basin since the Late Cretaceous. *Geological Society of America Abstracts with Programs* 38(7): 518.
- Mayr, E. 1963. *Animal Species and Evolution*. Belknap Press, Cambridge.
- Molina, J. & L. Struwe. 2008. Revision of ring-gentians (*Symbolanthus*, Gentianaceae) from Bolivia, Ecuador, and Peru, with a first assessment of conservation status. *Syst. Biodivers.* 6: 477–501.
- Morawetz, W. & C. Raedig. 2007. Angiosperm biodiversity, endemism and conservation in the Neotropics. *Taxon* 56: 1245–1254.
- Myers, N., R. A. Mittermeier, C. G. Mittermeier, G. A. B. da Fonseca & J. Kent. 2000. Biodiversity hotspots for conservation priorities. *Nature* 403: 853–858.
- Nixon, K. C. 1999–2002. WinClada, vers. 1.0. Published by the author, Ithaca, New York.
- & J. M. Carpenter. 1993. On outgroups. *Cladistics* 9: 413–426.
- Perret, M., A. Chautems, R. Spichiger, G. Kite & V. Savolainen. 2003. Systematics and evolution of tribe Sinningieae (Gesneriaceae): Evidence from phylogenetic analyses of six plastid DNA regions and nuclear ncpGS. *Amer. J. Bot.* 90: 445–460.
- , ———, ———, T. G. Barraclough & V. Savolainen. 2007. The geographical pattern of speciation and floral diversification in the Neotropics: The tribe Sinningieae (Gesneriaceae) as a case study. *Evolution* 61: 1641–1660.
- Peterson, E. T., J. Soberón & V. Sánchez-Cordero. 1999. Conservatism of ecological niches in evolutionary time. *Science* 285: 1265–1267.
- Rambaut, A. 2002. Se-AL: Sequence Alignment Editor, vers. 2.0a11. <<http://tree.bio.ed.ac.uk/software/seal/>>, accessed 1 November 2008.
- Rodríguez-Mahecha, J. V., P. Salaman, P. Jørgensen, T. Consiglio, L. Suárez, F. Arjona & R. Bensted-Smith. 2004a. Tropical Andes. Pp. 73–79 in R. A. Mittermeier, P. Robles-Gil, M. Hoffmann, J. D. Pilgrim, T. M. Brooks, C. G. Mittermeier & G. Fonseca (editors), *Hotspots Revisited: Earth's Biologically Richest and Most Endangered Ecoregions*, 2nd ed. CEMEX, Mexico City.
- , ———, ———, ———, E. Forno, A. Telesca, L. Suárez, F. Arjona, F. Rojas, R. Bensted-Smith & V. H. Inchausty. 2004b. Tumbes–Chocó–Magdalena. Pp. 80–84 in R. A. Mittermeier, P. Robles-Gil, M. Hoffmann, J. D. Pilgrim, T. M. Brooks, C. G. Mittermeier & G. Fonseca (editors), *Hotspots Revisited: Earth's Biologically Richest and Most Endangered Ecoregions*, 2nd ed. CEMEX, Mexico City.
- Ronquist, F. 1996. DIVA, vers. 1.1. Published by the author, Uppsala.
- . 1997. Dispersal-vicariance analysis: A new approach to the quantification of historical biogeography. *Syst. Biol.* 46: 195–203.
- Struwe, L. 2008. SEEVA: Spatial Evolutionary and Ecological Vicariance Analysis. Rutgers University, New Brunswick, New Jersey. <<http://www.rci.rutgers.edu/~struwe/seeva/>>, accessed 21 November 2008.
- , J. Kadereit, J. Klackenberg, S. Nilsson, M. Thiv, K. B. von Hagen & V. A. Albert. 2002. Systematics, character evolution, and biogeography of Gentianaceae, including a new tribal and subtribal classification. Pp. 21–309 in L. Struwe & V. A. Albert (editors), *Gentianaceae: Systematics and Natural History*. Cambridge University Press, Cambridge.
- , V. A. Albert, M. F. Calió, C. Frasier, K. B. Lepis, K. G. Mathews & J. R. Grant. 2009. Evolutionary patterns in neotropical tribe Helieae (Gentianaceae): Evidence from morphology, chloroplast and nuclear DNA sequences. *Taxon* 58: 479–499.
- Swofford, D. L. 2000. PAUP.* Phylogenetic Analysis Using Parsimony (*and Other Methods), Vers. 4. Sinauer Associates, Sunderland, Massachusetts.
- Thompson, J. D., T. J. Gibson, F. Plewniak, F. Jeanmougin & D. G. Higgins. 1997. The ClustalX windows interface: Flexible strategies for multiple sequence alignment aided by quality analysis tools. *Nucl. Acids Res.* 25: 4876–4882.
- van der Hammen, T. 1979. History of flora, vegetation and climate in the Colombian Cordillera Oriental during the last five million years. Pp. 25–32 in K. Larsen & L. B. Holm-Nielsen (editors), *Tropical Botany*. Academic Press, London.
- Weigend, M. 2002. Observations on the biogeography of the Amotape-Huancabamba zone in northern Peru. *Bot. Rev.* 68: 38–54.
- . 2004. Additional observations on the biogeography of the Amotape-Huancabamba zone in northern Peru: Defining the south-eastern limits. *Revista Peru Biol.* 11: 127–134.
- Young, K., C. Ulloa Ulloa, J. L. Luteyn & S. Knapp. 2002. Plant evolution and endemism in Andean South America: An introduction. *Bot. Rev.* 68: 4–21.
- Young, K. R. & C. Reynel. 1997. Huancabamba Region: Peru and Ecuador. Pp. 465–469 in S. D. Davis, V. H. Heywood, O. Herrera-MacBryde, J. Villa-Lobos & A. Hamilton (editors), *Centres of Plant Diversity: A Guide and Strategy for Their Conservation*, Vol. 3. The Americas. IUCN Publications Unit, Cambridge.
- Yuan, Y.-M., S. Wohlhauser, M. Möller, P. Chassot, G. Mansion, J. Grant, P. Küpfer & J. Klackenberg. 2003. Monophyly and relationships of the tribe Exaceae (Gentianaceae) inferred from nuclear ribosomal and chloroplast DNA sequences. *Molec. Phylogen. Evol.* 28: 500–517.

APPENDIX 1

Optimal distributions from the DIVA analysis listed for each node (ancestor of terminals [AOT]; node numbers in Fig. 3; letters refer to legend for Fig. 4). Note that optimizations in Figure 4 sometimes reflect a dispersal event at a terminal branch that might be indicated as a joint distribution in the list below, because changes in area distributions on terminal branches are not mapped with DIVA. Optimizations outside of *Macrocarpaea* are not listed here, and due to the collapse of groups with homogenous areas (see Materials and Methods), some node numbers are not listed here.

- Node 6, AOT *M. obtusifolia*–*M. normae*: AB AC ABC AD ABD ACD ABE AF ABF ACF ADF AG ABG ACG ADG AFG AH ABH ACH ADH AFH AGH
- Node 9, AOT *M. glabra*–*M. normae*: CD CF CDF CG CDG CFG DH CDH FH CFH DFH GH CGH DGH FGH
- Node 10, AOT *M. glabra*–*M. macrophylla*: F G DG FG DFG

-
- Node 11, AOT *M. gondolooides*–*M. macrophylla*: F DF FG
DFG EFG
Node 13, AOT *M. valerioi*–*M. macrophylla*: D DF DEF DG
EG DEG FG DFG EFG
Node 14, AOT *M. auriculata*–*M. macrophylla*: DE DF DEF
Node 16, AOT *M. valerioi*–*M. papillosa*: DG
Node 17, AOT *M. glabra*–*M. nicotianifolia*: G FG BFG EFG
Node 18, AOT *M. neblinae*–*M. nicotianifolia*: EF BEF BG
BEG FG BFG EFG
Node 19, AOT *M. gaudialis*–*M. nicotianifolia*: EG
Node 22, AOT *M. neblinae*–*M. gattaca*: BF
Node 23, AOT *M. pinetorum*–*M. normae*: CH
Node 26, AOT *M. arborescens*–*M. normae*: H
Node 27, AOT *M. viscosa*–*M. normae*: HI HJ HIJ
Node 28, AOT *M. viscosa*–*M. pajonalis*: H
Node 29, AOT *M. bangiana*–*M. pajonalis*: HJ
Node 30, AOT *M. subsessilis*–*M. pajonalis*: H
Node 32, AOT *M. jensii*–*M. pajonalis*: H
Node 33, AOT *M. chthonotropa*–*M. pajonalis*: H
Node 34, AOT *M. noctiluca*–*M. pajonalis*: H
Node 39, AOT *M. ericii*–*M. pajonalis*: HI
Node 43, AOT *M. pringleana*–*M. sodiroana*: FH EFH
Node 44, AOT *M. jensii*–*M. sodiroana*: H
Node 49, AOT *M. viscosa*–*M. pachystyla*: HI
Node 50, AOT *M. luna-gentiana*–*M. pachystyla*: H
Node 51, AOT *M. zophoflora*–*M. pachystyla*: HJ
Node 52, AOT *M. fortisiana*–*M. pachystyla*: J
Node 53, AOT *M. maguirei*–*M. pachystyla*: IJ
Node 54, AOT *M. cochabambensis*–*M. normae*: IJ
Node 55, AOT *M. revoluta*–*M. normae*: I
Node 56, AOT *M. weigendiorum*–*M. normae*: I
Node 57, AOT *M. ostentans*–*M. normae*: I IJ
Node 58, AOT *M. robin-fosteri*–*M. normae*: I
Node 59, AOT *M. robin-fosteri*–*M. jactans*: HI
Node 60, AOT *M. tahuantinsuyuana*–*M. normae*: IJ
Node 61, AOT *M. cinchonifolia*–*M. normae*: J

DETERMINANTS AND PREDICTION OF BROAD-SCALE PLANT RICHNESS ACROSS THE WESTERN NEOTROPICS¹

Trisha Distler,² Peter M. Jørgensen,³
Alan Graham,⁴ Gerrit Davidse,⁵
and Iván Jiménez⁶

ABSTRACT

Patterns of broad-scale plant species richness are thought to be largely determined by (1) variation in energy and water availability among sampling units (species energy hypothesis), (2) habitat and topographic heterogeneity within sampling units (spatial heterogeneity hypothesis), and (3) regional differences in geographic configuration and history (regional effects hypothesis). However, lack of taxonomic and distribution data, particularly for tropical regions, has impeded assessments of the relative importance of these three hypotheses. We used a large botanical database to estimate the pattern of relative vascular plant richness across the western Neotropics and regression models to measure the extent to which this estimated pattern supported predictions from each of the above three hypotheses. Variation in plant richness across three major paleophysiographic regions (northwest South America, southern Central America, and northern Central America) was primarily predicted by the spatial heterogeneity hypothesis, with secondary contributions from the species energy hypothesis and, to a lesser extent, the regional effects hypothesis. Regression models that incorporated the relative contributions of all three hypotheses predicted peaks of relative species richness mostly in topographically complex areas (e.g., Sierra Madre de Chiapas, Cordillera de Tilarán, Cordillera de Talamanca, Panama's Cordillera Central, the Andes, and the Venezuelan Guayana); relatively low richness in central Mexico and Yucatán, Los Llanos of Venezuela, and in the Gran Chaco region of Bolivia, Paraguay, and Argentina; and a richness trough in lowland Amazonia relative to southern Central America, the Andes, and the Venezuelan Guayana. We discussed the contrast between our results and previous assessments that found plant richness to be primarily determined by the species energy hypothesis and predicted different patterns of plant richness across the western Neotropics.

Key words: Broad-scale species richness, Neotropics, regional effects, spatial heterogeneity, species energy, vascular plants.

Patterns of spatial variation in the number of species co-occurring within broad geographic areas were discussed by naturalists of the 18th and 19th centuries (von Humboldt, 1808; Darwin, 1862; Wallace, 1878; see Hawkins, 2001), and more rigorous attempts to quantify these patterns began during the last century (e.g., Wulff, 1935; Simpson, 1964; see Mutke & Barthlott, 2005) along with the formulation of numerous hypotheses to explain them (Hutchinson, 1959; Pianka, 1966; Huston, 1979, 1994; Rohde, 1992; Palmer, 1994; Rosenzweig, 1995; Schemske, 2002; Willig et al., 2003). Yet, understanding what determines broad-scale spatial patterns of species richness still remains a central issue in ecology and biogeography (Gaston, 2000; Ricklefs, 2004; Pennisi, 2005). Recent work in this area has focused on a few prominent hypotheses,

notably the species energy (SE), spatial heterogeneity (SH), and regional effects (RE) hypotheses.

The SE, broadly defined, holds that gradients of energy and water availability across sampling units create and maintain species-richness patterns (Hutchinson, 1959; Pianka, 1966; Brown, 1981; O'Brien, 1993; Rosenzweig, 1995) through a variety of nonexclusive mechanisms (Hawkins et al., 2003; Currie et al., 2004; Evans et al., 2005; Clarke & Gaston, 2006) including the effects of these gradients on extinction (Wright, 1983), evolutionary rates (Rohde, 1992; Evans & Gaston, 2005), and species filtering according to physiological requirements (von Humboldt, 1808; Turner et al., 1987). The SH posits that variation in elevation and habitat within sampling units increases richness, again through various nonexclusive mechanisms, including species sorting

¹ We are grateful to B. Magill for major assistance handling Tropicos data. R. Field, J. Mutke, and one anonymous reviewer provided insightful criticism that enhanced the quality of our work.

² Center for Conservation and Sustainable Development, Missouri Botanical Garden, P.O. Box 299, St. Louis, Missouri 63166-0299, U.S.A. trisha.distler@mobot.org.

³ Missouri Botanical Garden, P.O. Box 299, St. Louis, Missouri 63166-0299, U.S.A. peter.jorgensen@mobot.org.

⁴ Missouri Botanical Garden, P.O. Box 299, St. Louis, Missouri 63166-0299, U.S.A. alan.graham@mobot.org.

⁵ Missouri Botanical Garden, P.O. Box 299, St. Louis, Missouri 63166-0299, U.S.A. gerrit.davidse@mobot.org.

⁶ Center for Conservation and Sustainable Development, Missouri Botanical Garden, P.O. Box 299, St. Louis, Missouri 63166-0299, U.S.A. Author for correspondence: ivan.jimenez@mobot.org.

doi: 10.3417/2008034

among habitats (Rosenzweig, 1995) or isolated patches of similar habitats (Simpson, 1964) and the effect of spatial heterogeneity on diversification rates (Simpson, 1964; Jetz et al., 2004). The RE proposes that differences in richness between sampling units with similar environments but located in different regions (i.e., diversity anomalies) result from regional disparities in history and geographic configuration that, in turn, cause differences in the occurrence of particular lineages, time available for diversification, and rates of species production and extinction (Pianka, 1966; Latham & Ricklefs, 1993; Schluter & Ricklefs, 1993; Qian & Ricklefs, 2000).

Many ecologists seem to agree that some combination of the three hypotheses above provides the best, currently available, explanation of broad-scale spatial patterns of species richness (Rahbek & Graves, 2001; Ricklefs et al., 2004; Field et al., 2005; Kreft & Jetz, 2007). However, progress in establishing the relative importance of these hypotheses as explanations of broad-scale patterns of plant species richness has been hindered by the scarcity of taxonomically and spatially resolved data sets (Whittaker et al., 2005), particularly for tropical regions (Frodin, 2001; but see Kier et al., 2005). Thus, most studies are focused on a few relatively well-known life forms (e.g., Currie & Paquin, 1987; O'Brien, 1998; Field et al., 2005) or taxonomic groups (e.g., Bjorholm et al., 2005). Other studies are based on floras, checklists, and other literature sources that have little information on sampling effort (e.g., Kreft & Jetz, 2007). Yet, failure to account for sampling effort can alter our perception of spatial patterns of plant richness (Nelson et al., 1990; Parnell et al., 2003). Here, we expanded on previous efforts to overcome these problems (Jiménez et al., 2009) by assessing the relative importance of the SE, SH, and RE in determining broad-scale patterns of vascular plant species richness across the western Neotropics. In addition, we used results on the relative importance of different hypotheses to predict relative plant species richness in areas of the western Neotropics with poorly sampled floras.

METHODS

To describe the spatial pattern of vascular plant species richness across the western Neotropics, we used 755,401 georeferenced herbarium specimen records from the Tropicos database (<http://www.tropicos.org/>, Missouri Botanical Garden), representing 48,264 plant species collected in central Mexico, Belize, Guatemala, Honduras, Nicaragua, Costa Rica, Panama, French Guiana, Guyana, Venezuela, Colombia, Ecuador, Peru, Bolivia, Uruguay, and northern Argentina. We mapped these data on a

Behrmann cylindrical equal-area projection of the study area and used rarefaction (Gotelli & Colwell, 2001) to estimate relative species richness in 100×100 km sampling units as the expected number of species in a random sample of size n from a set of N herbarium specimen records. To choose the value of n at which relative richness was measured using rarefaction, we balanced the benefits of increasing n in terms of increased precision of relative richness estimates against the corresponding costs in terms of decreased sample size (Fig. 1; Jiménez et al., 2009). We judged $n = 500$ herbarium specimen records to be a reasonable compromise and retained 255 sampling units with at least 500 specimen records for further analysis (Fig. 2A, B).

Admittedly, rarefaction is unlikely to account for all error in estimates of relative richness due to differences in sampling effort, because the set of N herbarium specimens collected in a single sampling unit is unlikely to be a random sample from the individuals of all vascular plants occurring in that sampling unit (Jiménez et al., 2009). Therefore, our estimates of relative plant richness contain potentially large measurement errors that, nonetheless, can be reasonably subsumed in the error term of statistical models representing different hypotheses. Such measurement errors may affect the conclusions from our analysis mainly in proportion to its correlation with the explanatory variables relevant to the three hypotheses of interest (Jiménez et al., 2009). As a starting point, we assumed such correlation was negligible.

We used a set of regression models to simultaneously measure the extent to which the estimated pattern of relative plant richness across the western Neotropics (Fig. 2A) supported predictions from the SE, SH, and RE. For each regression model, we derived predictions from one or more hypotheses about the sign of regression coefficients relating explanatory variables to relative plant richness. Some regression models included higher-order terms (i.e., interaction or quadratic terms) that may account for small portions of the variation in the response variable when the range of the relevant explanatory variable is limited. Therefore, when the coefficients of higher-order terms were not statistically significant, we examined the performance of reduced models with no higher-order terms in an attempt to trade-off a tolerable bias for increased precision (Chatterjee & Hadi, 1988). In these reduced models, the predicted sign for regression coefficients may depend on the range and central tendency of explanatory variables. We derived predictions for the sign of regression coefficients in reduced models based on the range of explanatory variables in our sample (Fig. 3) and the

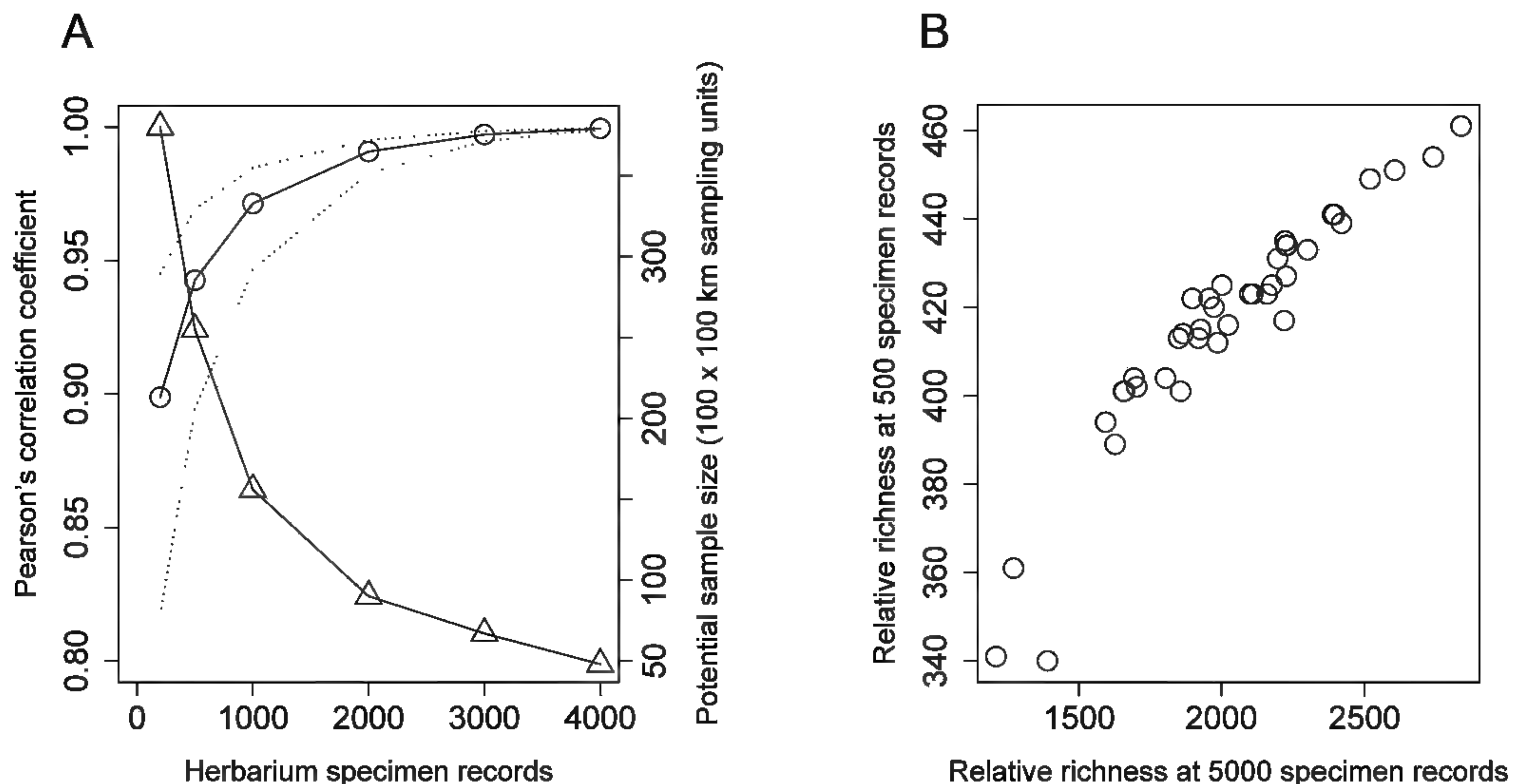

Figure 1. Trade-off between precision and sample size. —A. Pearson's correlation coefficients (line and circles) and their 95% confidence intervals (dotted lines) for the relationship between richness estimated by rarefaction as the expected number of species in 5000 specimen records and richness estimated by rarefaction at various other numbers of specimen records (in the abscissa): 4000, 3000, 2000, 1000, 500, and 200. The sample to estimate all these correlations was a set of 41 sampling units of 100×100 km, each with at least 5000 herbarium specimen records. Also shown is the potential sample size (line and triangles): the number of sampling units in our study area that would be available for analysis if richness estimates based on rarefaction at a given number of specimen records were deemed acceptable. By deciding to estimate richness at 500 specimen records we adopted a somewhat conservative approach, trading off increases in potential sample size above 255 sampling units for relatively precise richness estimates. —B. Relationship between relative plant richness estimated by rarefaction at 5000 herbarium specimen records (in the abscissa) and 500 herbarium specimen records (in the ordinate) across 41 sampling units of 100×100 km, each with at least 5000 specimen records.

values of regression coefficients obtained by previous studies (O'Brien, 1998; Francis & Currie, 2003; Field et al., 2005).

The SE was represented by three models thought to explain a major portion of broad-scale spatial variance in plant richness worldwide (O'Brien, 1998; Francis & Currie, 2003; Field et al., 2005; Table 1). Importantly, we selected data sources to reflect the original formulation of each model as closely as possible. Thus, for SE models 1 and 2 (Francis & Currie, 2003; Table 1) we obtained annual potential evapotranspiration and water deficit from Ahn and Tateishi (1994), while for SE model 3 (O'Brien, 1998; Field et al., 2005; Table 1) we calculated minimum monthly potential evapotranspiration using mean monthly temperature and Thornthwaite's formula (Thornthwaite, 1948; see details in Jiménez et al., 2009). We obtained data for mean annual temperature, mean monthly temperature, and annual precipitation from WorldClim (<<http://www.worldclim.org/>>; Hijmans et al., 2005).

The SH was represented by three regression models based on hypothesized effects on plant richness of within-sampling-unit spatial variation in elevation (Currie & Paquin, 1987; O'Brien et al., 2000; Kreft & Jetz, 2007), climate (Currie & Paquin, 1987; Linder, 2003), and soil (Linder, 2003; Tuomisto et al., 2003;

Gentry, 1988; Table 1). We calculated variance in elevation within each sampling unit from elevation data at a resolution of 90×90 m (Shuttle Radar Topography Mission, USGS, 2004). We derived spatial variation in climate within sampling units from 19 variables measuring various aspects of temperature and precipitation at a resolution of 30 arcseconds, obtained from WorldClim. Principal component analysis on these 19 variables captured 89.4% of the total variation in the first three principal components. Because variance within sampling units in these three principal components was highly correlated (Pearson's $r > 0.75$; $P < 0.05$), we used only the variance within sampling units in the first principal component as an explanatory variable. We calculated variance in available water capacity and soil carbon density within each sampling unit from data at a 5×5 min. resolution (Global Soil Data Task).

We also considered regression models that combined terms representing the SE and SH. One model was the Interim General Model second-generation (IGM2) (O'Brien et al., 2000; Field et al., 2005; Table 1), regarded as one of the best working models to explain broad-scale patterns of woody plant richness (O'Brien et al., 2000; Field et al., 2005;

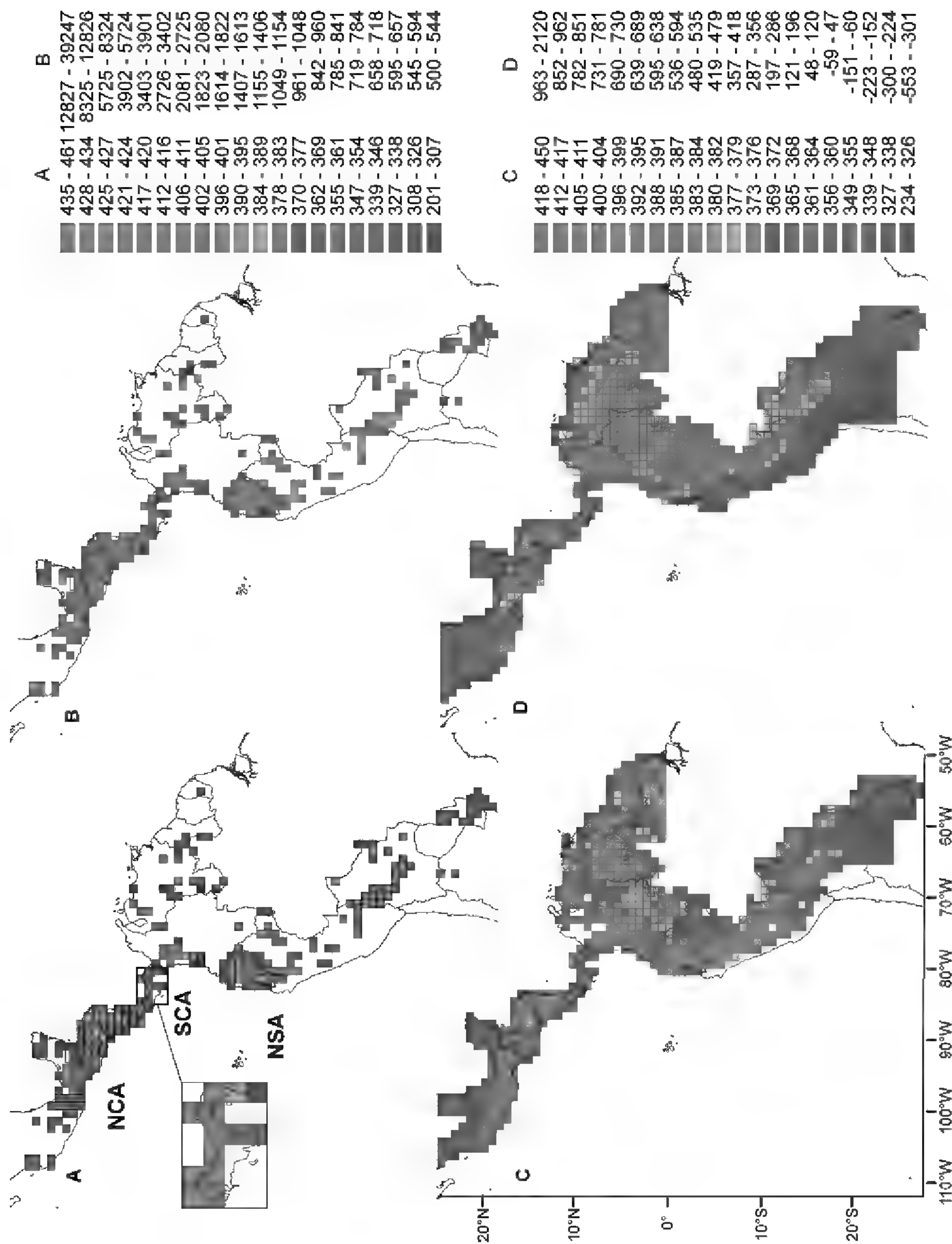

Figure 2. Relative plant richness and botanical sampling effort in 255 sampling units of 100 × 100 km distributed across the western Neotropics. Each color represents an interval of five percentiles, from high (red) to low (blue). —A. Observed richness measured as the average number of species found in 1000 rarefied samples of 500 herbarium specimen records. —B. Number of herbarium specimen records. —C. Predicted relative richness based on the fit of the data in A to the nonspatial version of Interim General Model second-generation (IGM2) with regional effects (Table 2). Prediction is restricted to the sample range of explanatory variables. —D. Woody plant species richness as predicted by the global coefficients for the IGM2 (Field et al., 2005). No woody plants are predicted to occur in sampling units with negative values. NCA, N Central America; SCA, S Central America; NSA, N South America.

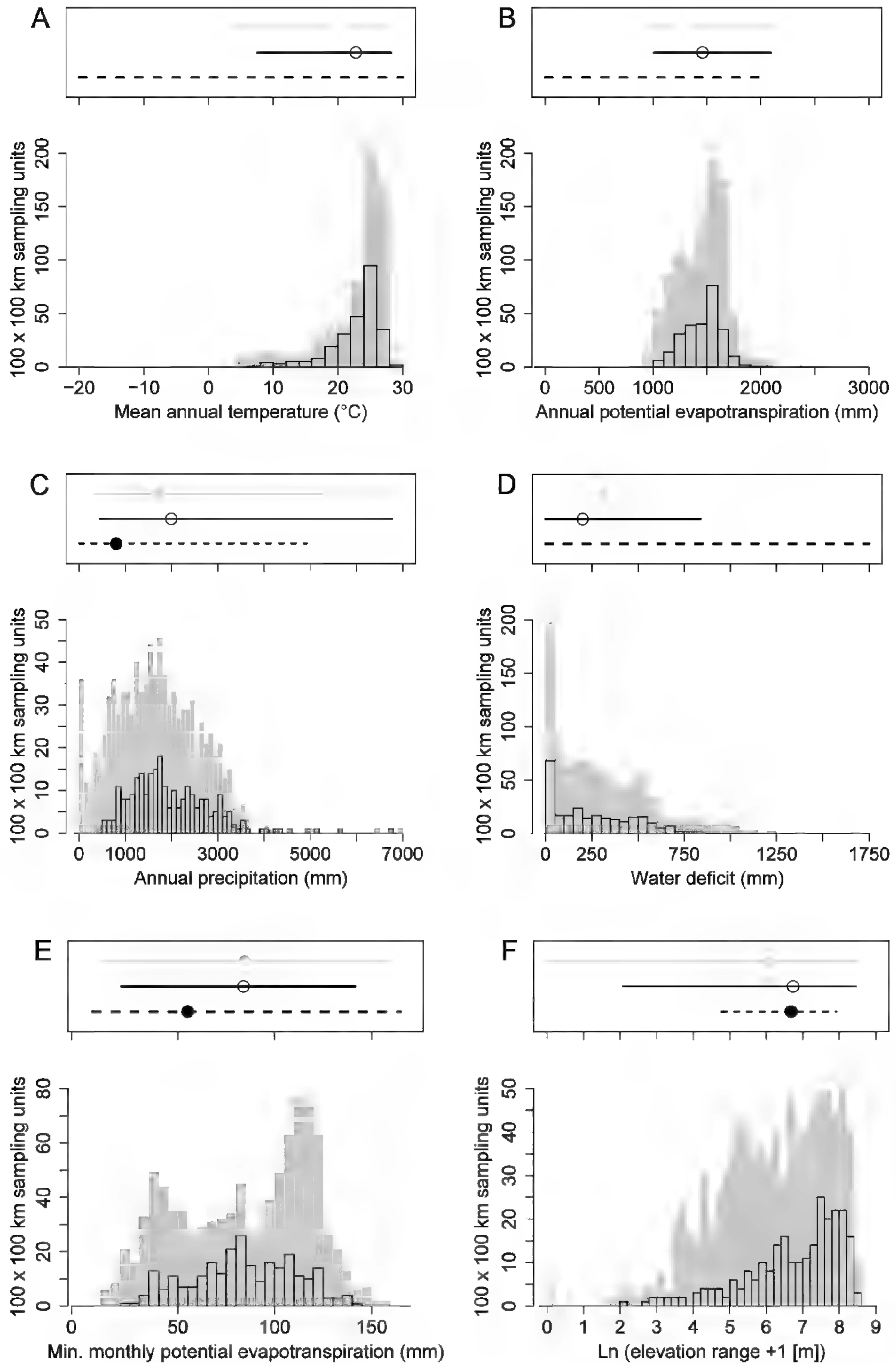

Figure 3. Distribution of explanatory variables across the western Neotropics (gray bars), and our sample of the study area (bars with black outline). At the top of each histogram, a line and a dot represent the range and mean, respectively, for the western Neotropics (gray), our sample of the study area (black), and samples used to generate species energy (SE) models and the globally specified Interim General Model second-generation (IGM2) (dashed line). The summary statistics for values of mean annual temperature (A), water deficit (D), and potential evapotranspiration (B) in the samples used to generate SE

Clarke & Gaston, 2006). While the IGM2 was specifically developed for woody plants, its conceptual basis is general and allows application to all plants, at least as an approximate representation of the SE and SH. To replicate as closely as possible the original formulation of the IGM2, we estimated elevation range for each sampling unit using the GTOPO30 arcsecond elevation data set (USGS, 2004) resampled to 10×10 km. We constructed additional models combining terms representing the SE and SH that yielded significant ($P < 0.05$) regression coefficients that were consistent with the respective predictions in all previous regression models. We examined all combinations of these explanatory variables, except when they were highly correlated. For brevity, we presented only the models with more empirical support as measured by the Akaike Information Criterion corrected (AICc) for small sample sizes, recommended when the ratio of sampling units to model parameters is less than 40 (Burnham & Anderson, 2002). Given the procedure used to construct these latter models, we refer to them as ad hoc models (Table 1).

The RE was represented by regression models that also included terms representing both the SE and SH (Table 2). This approach follows from the idea that regional effects account for variation in species richness that remains after the effect of environmental conditions of the sampling units has been accounted for (Schluter & Ricklefs, 1993). We added regional effects to regression models using dummy variables (Draper & Smith, 1998) to code intercepts and slopes for each of three major paleogeographic regions of the Neotropics (Graham, 1997): central Mexico through northern Costa Rica (N Central America), southern Costa Rica and Panama (S Central America), and northern South America (N South America). There are at least two well-known major differences in the history of these paleogeographic regions (Graham, 1997; Burnham & Graham, 1999): (1) N South America was isolated from N Central America for tens of millions of years, and (2) unlike N South America and N Central America, S Central America emerged from the sea just a few million years ago. In addition, the three regions were probably differentially influenced by orogenic activity, and by late Cenozoic fluctuations in climate and sea level associated with glacial advances and retreats that intensified during the Quaternary (Graham, 1997; Burnham & Graham, 1999). Following previous

approaches to examine regional effects (Schulter & Ricklefs, 1993; Ricklefs et al., 2004), we predicted differences among regions but not the direction of such differences. Variables representing the RE were removed from regression models if they did not reduce AICc values, following model simplification procedures suggested by Crawley (2002).

To confront the estimated pattern of relative plant richness across the western Neotropics (Fig. 2A) against the models representing different hypotheses, we used quantile regression through the median (Cade et al., 2005), implemented using R package *quantreg* (Koenker, 2005, 2008; R Development Core Team, 2006). We used regression through the median rather than least squares, because the response variable measures plant richness in an ordinal scale and meaningful hypotheses about variables in an ordinal scale focus on order statistics such as the median (Wolman, 2006). We gauged the extent to which the data supported different regression models examining the statistical significance of regression coefficients and their concordance with the predictions derived from the respective hypotheses. We also assessed support for different regression models using AICc. We calculated model fit in terms of R^1 , the proportion of the sum of absolute deviations from the median of the response variable that is accounted for by a regression model (Cade et al., 2005).

All regression models incorporated a covariate (logarithm of area) to account for reduced area in sampling units intersecting the border of the spatial extent of the study. Pairwise correlations among predictors (Table 3) showed that no predictors included together in a single regression model were highly correlated and, thus, collinearity was unlikely to be an issue. Furthermore, collinearity due to higher-order regression terms was alleviated by mean-centering the explanatory variables of models with higher-order terms (Quinn & Keough, 2003). We tested for spatial autocorrelation in regression residuals using a permutation test for Moran's I (Fortin & Dale, 2005), implemented with R package *spdep* (Bivand, 2008). When spatial dependence in the residuals was significant, we used spatial eigenvector mapping (SEVM; Dormann et al., 2007) to construct spatial regression models that estimated the relationship between relative species richness and explanatory variables in the absence of spatial autocorrelation in regression residuals. We used a forward-selection procedure to first include in quantile regression

← models come from Francis and Currie (2003). Summary statistics for values of annual mean precipitation (C) and minimum monthly potential evapotranspiration (E) in the samples used by Field et al. (2005) to generate the globally specified IGM2 come from O'Brien (1998), and those for elevation range (F) are from O'Brien et al. (2000).

Table 1. Results from median regression models representing the species energy (SE) and spatial heterogeneity (SH) hypotheses.

Models and variables	Pred	Regression coefficient, nonspatial	Regression coefficient, spatial
Model 1 SE, $R^1 = 0.039$ (0.212)			
Log10 area		55.34 (23.89) ^a	67.15 (20.26) ^c
Water deficit		0.02 (0.02)	0.02 (0.02)
Mean annual temperature	+	0.13 (0.11)	0.24 (0.07) ^c
Water deficit \times mean annual temperature		2×10^{-4} (5×10^{-4})	1×10^{-4} (3×10^{-4})
Eigenvector 3			119.08 (40.63) ^p
Eigenvector 2			210.64 (51.58) ^c
Eigenvector 5			109.42 (43.95) ^p
Eigenvector 4			138.61 (40.18) ^c
Eigenvector 12			186.20 (55.10) ^c
Eigenvector 6			164.99 (52.71) ^p
Model 1 SE reduced, $R^1 = 0.037$ (0.221)			
Log10 area		51.200 (24.81) ^a	44.58 (23.11)
Water deficit		0.021 (0.02)	0.02 (0.01)
Mean annual temperature	+	0.151 (0.12)	0.12 (0.07)
Eigenvector 2			176.65 (53.93) ^c
Eigenvector 3			131.52 (40.62) ^c
Eigenvector 5			98.36 (41.72) ^a
Eigenvector 12			193.03 (52.09) ^c
Eigenvector 6			164.89 (49.37) ^c
Eigenvector 15			158.76 (47.53) ^c
Model 2 SE, $R^1 = 0.084$ (0.177)			
Log10 area		47.80 (24.79) ^a	42.72 (24.06)
Water deficit		0.01 (0.02)	0.002 (0.01)
Annual potential evapotranspiration	+	0.05 (0.02) ^p	0.05 (0.02) ^a
Annual potential evapotranspiration ²	-	-3×10^{-4} (8×10^{-4}) ^c	3×10^{-4} (3×10^{-4}) ^p
Eigenvector 2			194.63 (49.93) ^c
Eigenvector 12			219.29 (52.03) ^c
Eigenvector 1			7.78 (51.64)
Eigenvector 3			93.58 (44.48) ^a
Model 3 SE, $R^1 = 0.109$ (0.200)			
Log10 area		63.52 (12.68) ^c	42.15 (17.37) ^a
Annual precipitation	+	0.01 (2×10^{-3}) ^c	0.01 (0.003) ^a
Min. monthly potential evapotranspiration	+	0.15 (0.13)	0.04 (0.15)
Min. monthly potential evapotranspiration ²		0.01 (3×10^{-3}) ^p	0.02 (0.01) ^c
Eigenvector 2			164.31 (47.71) ^p
Eigenvector 8			117.62 (51.81) ^a
Eigenvector 12			234.95 (57.95) ^c
Model 1 SH, $R^1 = 0.143$ (0.298)			
Log10 area		42.59 (15.44) ^p	37.97 (10.86) ^c
Log10 variance in elevation	+	16.477 (2.4) ^c	19.84 (2.11) ^c
Eigenvector 2			158.58 (29.35) ^c
Eigenvector 3			139.58 (27.87) ^c
Eigenvector 12			125.16 (45.66) ^p
Eigenvector 11			100.16 (33.61) ^p
Eigenvector 10			137.96 (33.53) ^c
Model 2 SH, $R^1 = 0.132$ (0.253)			
Log10 area		44.80 (24.91)	33.88 (22.81)
Log10 variance in climate PC 1	+	66.718 (6.37) ^c	60.75 (9.49) ^c
Eigenvector 2			173.27 (46.80) ^c
Eigenvector 3			124.51 (41.92) ^p

Table 1. Continued.

Models and variables	Pred	Regression coefficient, nonspatial	Regression coefficient, spatial
Eigenvector 12			147.93 (40.46) ^c
Eigenvector 15			101.07 (41.73) ^a
Model 3 SH, R ¹ = 0.051 (0.220)			
Log10 area		74.34 (23.89) ^p	53.16 (17.08) ^p
Log10 variance in available water capacity	+	10.21 (5.52)	12.78 (3.89) ^c
Log10 variance in soil carbon density	+	20.43 (8.33) ^p	22.46 (6.09) ^c
Eigenvector 2			126.86 (44.30) ^p
Eigenvector 3			102.54 (37.80) ^p
Eigenvector 7			121.81 (37.62) ^c
Eigenvector 12			278.07 (48.86) ^c
Eigenvector 6			146.83 (40.59) ^c
IGM2, R ¹ = 0.218 (0.274)			
Log10 area		50.79 (8.43) ^c	55.51 (9.93) ^c
Annual precipitation	+	0.011 (2 × 10 ⁻³) ^c	0.01 (0.003) ^c
Min. monthly potential evapotranspiration	+	0.298 (0.11) ^p	0.28 (0.12) ^a
Min. monthly potential evapotranspiration ²		0.003 (3 × 10 ⁻³)	0.01 (0.003)
Ln elevation range	+	15.037 (1.99) ^c	15.06 (2.01) ^c
Eigenvector 2			117.08 (41.17) ^p
Eigenvector 8			90.23 (42.97) ^a
Eigenvector 3			93.55 (39.41) ^a
Model 1 ad hoc, R ¹ = 0.254 (0.298)			
Log10 area		52.70 (8.83) ^c	59.35 (8.40) ^c
Annual precipitation	+	0.01 (0.002) ^c	0.01 (0.003) ^c
Min. monthly potential evapotranspiration	+	0.29 (0.10) ^p	0.27 (0.12) ^a
Min. monthly potential evapotranspiration ²		0.01 (0.003) ^a	0.002 (0.003)
Log10 variance in elevation	+	18.77 (1.98) ^c	19.64 (2.49) ^c
Eigenvector 2			110.38 (40.88) ^p
Eigenvector 3			109.42 (38.23) ^p
Eigenvector 8			109.61 (43.72) ^p
Model 2 ad hoc, R ¹ = 0.258 (0.300)			
Log10 area		49.93 (6.29) ^c	64.49 (7.37) ^c
Annual precipitation	+	0.01 (7 × 10 ⁻⁴) ^c	0.01 (0.003) ^c
Min. monthly potential evapotranspiration	+	0.280 (0.10) ^p	0.25 (0.11) ^a
Min. monthly potential evapotranspiration ²		0.01 (0.002) ^p	0.003 (0.003)
Log10 variance in soil carbon density	+	5.19 (3.38)	4.54 (3.59)
Log10 variance in elevation	+	18.477 (1.9) ^c	18.65 (2.35) ^c
Eigenvector 2			94.64 (38.38) ^p
Eigenvector 3			98.03 (34.85) ^p
Eigenvector 8			102.67 (40.44) ^p
Model 3 ad hoc, R ¹ = 0.254 (0.300)			
Log10 area		43.43 (10.82) ^c	60.95 (16.24) ^c
Annual precipitation	+	0.01 (0.003) ^c	0.01 (0.002) ^c
Potential evapotranspiration	+	0.001 (0.02)	0.03 (0.02)
Potential evapotranspiration ²		2 × 10 ⁻⁴ (2 × 10 ⁻⁴) ^a	1 × 10 ⁻⁴ (1 × 10 ⁻⁴)
Log10 variance in soil carbon density	+	8.289 (3.90) ^a	6.65 (4.45)
Log10 variance in elevation	+	16.025 (1.62) ^c	16.88 (2.07) ^c
Eigenvector 2			136.09 (39.45) ^c
Eigenvector 3			122.15 (31.55) ^c
Eigenvector 8			90.70 (40.97) ^a
Model 4 ad hoc, R ¹ = (0.303)			
Log10 area			47.47 (15.19) ^p
Potential evapotranspiration	+		0.02 (0.01)

Table 1. Continued.

Models and variables	Pred	Regression coefficient, nonspatial	Regression coefficient, spatial
Potential evapotranspiration ²			2×10^{-4} (2×10^{-4}) ^c
Log10 variance in elevation	+		16.19 (2.04) ^c
Eigenvector 2			174.42 (34.07) ^c

The response variable was relative plant species richness. The first column shows names of models and explanatory variables, as well as goodness of fit (R^1) for nonspatial regression models first and for spatial models in parentheses. The column labeled “Pred” shows the predicted signs of regression coefficients according to the respective hypothesis. The next two columns show regression coefficients for nonspatial and spatial models with standard errors in parentheses and statistical significance coded as: ^a, $P < 0.05$; ^b, $P < 0.01$; ^c, $P < 0.001$. PC, principal component; IGM2, Interim General Model second-generation; Log10, logarithm base 10; Ln, natural logarithm.

models those spatial eigenvectors that most reduced the spatial autocorrelation in the regression residuals (see Jiménez et al., 2009). Given that the interpretation of differences between coefficients derived from spatial and nonspatial regression models remains controversial (Dorman et al., 2007), we provided results from both types of models.

To predict relative plant richness across the western Neotropics, including areas that have been only sparingly collected, we used the predicted values from the regression models best supported by the data—that is, models that yielded statistically significant regression coefficients, were consistent with the respective predictions, and had the lowest AICc values. To avoid extrapolation, we predicted richness only in sampling units that fell within the range of explanatory variables in our sample of the western Neotropics (Fig. 3).

RESULTS

NONSPATIAL MODELS

The performance of nonspatial models representing a single hypothesis indicated that the SH had more empirical support than the SE. All three models representing the SH yielded significant regression coefficients consistent with the respective predictions, while only two out of three models representing the SE did so (Table 1). The AICc values for SH models 1 and 2 were notably lower than those for other models representing a single hypothesis, differing by > 17 (Fig. 4) and indicating large differences in empirical support. SH models 1 and 2 also accounted for a higher proportion of the variation in relative species richness ($R^1 = 0.143$ and 0.132 , respectively) than other models (Table 1). Thus, the relative performance of SH models 1 and 2 suggested a major role for variance (within sampling units) in elevation and climate, respectively, as determinants of plant richness across the study area.

The performance of models combining terms representing the SE and SH was, with no exception, superior to that of models representing a single hypothesis. Each of these four models yielded significant regression coefficients consistent with predictions from both the SE and SH (Table 1). AICc values for the IGM2 and ad hoc models 1 to 3 were substantially smaller than those for models representing an individual hypothesis, differing by > 41 (Fig. 4). In addition, the IGM2 and ad hoc models 1 to 3 accounted for more variation in relative richness ($R^1 > 0.21$) than models representing a single hypothesis (Table 1). The higher performance of ad hoc models 1 to 3 compared to models representing a single hypothesis and to the IGM2 could be partly due to over-fitting, given the ad hoc procedure used to build the former models (see Methods). However, we used the IGM2 as an a priori model and, therefore, at least in this case, the higher performance of a model that combines hypotheses relative to models that represent a single hypothesis indicates the complementary nature of the SE and SH.

All models that included terms representing the RE yielded significant regression coefficients consistent with predictions from both the SE and the SH. Each of these models also yielded significant coefficients representing regional effects (Table 2), but we had no predictions about their sign (see Methods). Models representing the RE did best overall, with lower AICc values differing by > 7 from models combining terms representing the SE and SH with no regional effects (Fig. 4), although respective differences in model fit were slight (Tables 1, 2). In general, the improvement in model performance accomplished by adding regional effects was smaller than that achieved by combining terms representing the SE and SH. This finding suggests that the RE, as represented in this study, does not complement the SE and SH to the same degree that the latter two hypotheses complement each other.

Nonetheless, adding regional effects to models representing the SE and SH decreased AICc values

substantially. For example, adding regional effects to the IGM2 decreased the AICc value by 23. The resulting model suggested that, after controlling for other environmental variables, relative richness was higher in S Central America than in N South America, and higher in N South America than in N Central America, across the range of minimum monthly potential evapotranspiration and annual precipitation in our sample (Fig. 5A, B). In addition, maximum plant richness was attained at higher values along the axis of minimum monthly potential evapotranspiration in N Central America than in S Central America and N South America (Fig. 5A). Relative plant richness increased faster with elevation range (within sampling units) in N Central America than in S Central America and N South America. Relative richness in sampling units with narrow elevation ranges was lower in N Central America than in S Central America and N South America, but the difference in relative richness decreased as elevation range increased (Fig. 5C). There were differences among ad hoc models in the strength and significance of regional effects, but all models revealed that N Central America, compared with S Central America and N South America, had a lower intercept and a steeper slope relating relative richness to variation in elevation within sampling units (Table 2).

SPATIAL MODELS

Similar to the results from nonspatial models, the performance of spatial models representing a single hypothesis indicated more empirical support for the SH than the SE. All three models representing the SH yielded significant regression coefficients consistent with the respective predictions (Table 1). However, SH model 3 also yielded a significant negative regression coefficient for variance in potential available water capacity, contrary to the respective prediction. Two of three models representing the SE, SE models 2 and 3, yielded significant regression coefficients consistent with the respective predictions, while SE model 1 yielded a significant negative regression coefficient for mean annual temperature, contrary to the respective prediction (Table 1). Among spatial models representing a single hypothesis, SH models 1 and 2 explained more variation in the response variable ($R^1 = 0.298$ and 0.253 , respectively; Table 1) and had substantially lower AICc values than the rest (Fig. 4), corroborating results from nonspatial models and suggesting a primary role for variance in elevation or climate, within sampling units, as determinants of plant richness across the study region.

Each of the five spatial models combining terms representing the SE and SH yielded statistically

significant regression coefficients that were consistent with the predictions derived from both hypotheses. In no case was there a statistically significant coefficient opposite to any prediction (Table 1). These models performed better than those representing an individual hypothesis, with a notable exception: the spatial version of SH model 1, which described a positive relationship between variance in elevation within sampling units and relative plant richness, explained more variation in the response variable and had a substantially lower AICc value than the IGM2, in both metrics similar to ad hoc models 1 to 4 (Table 1; Fig. 4). This exception strengthens the previous suggestion that variance in elevation within sampling units, a variable representing the SH, was a primary determinant of plant richness across the study region. It also suggests that spatial eigenvectors accounted for variation in relative plant richness that correlated with variables representing the SE, but not for variation in relative plant richness that correlated with variables representing the SH.

All spatial models including terms representing the RE yielded statistically significant regression coefficients consistent with predictions from both the SE and SH, as well as significant coefficients representing regional effects. In only one case was there a statistically significant coefficient opposite to a prediction: ad hoc model 3 with regional effects yielded a negative coefficient for potential evapotranspiration (Table 2). Spatial models including regional effects explained only a slightly higher proportion of the variation in the response variable than models including terms representing the SE and SH only (Tables 1, 2), and their AICc values were not consistently lower than those of other models (Fig. 4). This result contrasts with the respective comparison for nonspatial models and suggests that spatial eigenvectors accounted for variation in relative plant richness that correlated with variables representing the RE. Nonetheless, a spatial model including regional effects yielded the lowest AICc (ad hoc model 2; Fig. 4) and the highest proportion of explained variation in relative species richness ($R^1 = 0.326$; Table 2). This model revealed similar regional effects to those described by nonspatial models, whereby N Central America compared to other paleophysiographic regions had a lower intercept and a steeper slope relating relative richness to variance in elevation within sampling units (Table 2; Fig. 5D–F).

PREDICTED PLANT RICHNESS MAPS

The models best supported by the data yielded similar patterns of predicted relative species richness

Table 2. Results from median regression models combining the species energy, spatial heterogeneity, and regional effects hypotheses.

Models and variables	Pred	Regression coefficient, nonspatial	Regression coefficient, spatial
IGM2, $R^1 = 0.263$ (0.297)			
Log10 area		55.54 (13.49) ^c	64.749 (18.32) ^c
Annual precipitation	+	0.01 (0.002) ^c	0.01 (0.003) ^c
Min. monthly potential evapotranspiration	+	0.15 (0.14)	0.07 (0.13)
Min. monthly potential evapotranspiration ²		0.01 (0.004) ^p	0.01 (0.004) ^p
Ln elevation range		10.39 (1.95) ^c	10.55 (1.91) ^c
NCA		112.35 (21.65) ^c	111.42 (30.07) ^c
SCA		23.63 (11.96) ^a	29.22 (9.24) ^p
Min. monthly potential evapotranspiration × NCA		0.87 (0.28) ^p	0.70 (0.35) ^a
Ln elevation range × NCA		16.00 (3.23) ^c	15.15 (4.34) ^c
Eigenvector 3			140.92 (31.76) ^c
Eigenvector 2			74.53 (53.74)
Model 1 ad hoc, $R^1 = 0.284$ (0.308)			
Log10 area		50.87 (7.61) ^c	65.41 (7.34) ^c
Annual precipitation	+	0.01 (0.002) ^c	0.01 (0.002) ^c
Min. monthly potential evapotranspiration	+	0.14 (0.13)	0.001 (0.12)
Min. monthly potential evapotranspiration ²		0.01 (0.004) ^c	0.01 (0.003) ^a
Log10 variance in elevation	+	14.73 (2.49) ^c	14.13 (2.18) ^c
NCA		70.49 (22.79) ^p	60.06 (28.04) ^a
SCA		59.05 (50.46)	102.91 (53.73)
Annual precipitation × SCA		0.03 (0.01) ^c	0.04 (0.01) ^p
Min. monthly potential evapotranspiration × NCA		0.72 (0.25) ^p	0.69 (0.25) ^p
Log10 variance in elevation × NCA		14.06 (4.67) ^p	10.95 (5.61) ^a
Log10 variance in elevation × SCA		24.58 (10.52) ^a	-33.43 (11.63) ^p
Eigenvector 3			-153.32 (29.98) ^c
Model 2 ad hoc, $R^1 = 0.277$ (0.326)			
Log10 area		48.65 (9.44) ^c	50.08 (13.57) ^c
Annual precipitation	+	0.01 (0.002) ^c	0.01 (0.003) ^p
Min. monthly potential evapotranspiration	+	0.31 (0.11) ^p	0.33 (0.12) ^p
Min. monthly potential evapotranspiration ²		0.01 (0.003) ^p	0.01 (0.003) ^a
Log10 variance in soil carbon density	+	10.15 (3.72) ^p	3.77 (3.40)
Log10 variance in elevation	+	15.36 (2.42) ^c	15.36 (2.49) ^c
NCA		111.96 (30.75) ^c	86.68 (36.12)
Annual precipitation × NCA		0.01 (0.01) ^a	2×10^{-4} (0.01)
Log10 variance in elevation × NCA		17.84 (5.40) ^c	17.90 (6.11) ^p
Eigenvector 8			98.63 (35.58) ^p
Eigenvector 2			149.03 (40.37) ^c
Eigenvector 10			112.11 (31.40) ^c
Model 3 ad hoc, $R^1 = 0.291$ (0.304)			
Log10 area		48.25 (8.73) ^c	44.42 (11.41) ^c
Annual precipitation	+	0.01 (0.003) ^c	0.01 (0.003) ^c
Annual potential evapotranspiration	+	0.04 (0.02)	0.06 (0.02) ^p
Annual potential evapotranspiration ²		3×10^{-4} (1×10^{-4}) ^c	3×10^{-4} (1×10^{-4}) ^c
Log10 variance in soil carbon density	+	10.81 (3.85) ^p	13.95 (4.55) ^p
Log10 variance in elevation	+	12.22 (1.95) ^c	11.24 (2.45) ^c
NCA		56.45 (17.41) ^c	62.95 (22.46) ^p
SCA		25.56 (9.52) ^p	26.78 (12.07) ^a
Annual potential evapotranspiration × NCA		0.14 (0.05) ^p	0.17 (0.04) ^c
Log10 variance in elevation × NCA		10.74 (3.59) ^p	12.21 (4.55) ^p
Eigenvector 7			97.57 (42.37) ^a
Model 4 ad hoc, $R^1 = 0.272$			
Log10 area			57.32 (13.73) ^c

Table 2. Continued.

Models and variables	Pred	Regression coefficient, nonspatial	Regression coefficient, spatial
Annual potential evapotranspiration	+		0.02 (0.02)
Annual potential evapotranspiration ²			2×10^{-4} (2×10^{-4}) ^a
Log10 variance in elevation	+		15.11 (1.94) ^c
NCA			17.78 (7.04) ^a
SCA			32.58 (7.35) ^c
Annual potential evapotranspiration \times NCA			0.07 (0.05)
Eigenvector 3			184.55 (35.16) ^c
Eigenvector 2			83.90 (33.53) ^a

The response variable was relative plant species richness. The first column shows names of models and explanatory variables, as well as goodness of fit (R^2) for nonspatial regression models first and for spatial models in parentheses. The column labeled “Pred” shows the predicted signs of regression coefficients according to the respective hypothesis. The next two columns show regression coefficients for nonspatial and spatial models with standard errors in parentheses and statistical significance coded as: ^a, $P < 0.05$; ^b, $P < 0.01$; ^c, $P < 0.001$. IGM2, Interim General Model second-generation; Log10, logarithm base 10; Ln, natural logarithm; NCA, dummy variable for N Central America; SCA, dummy variable for S Central America.

across the western Neotropics (Figs. 2C, 6A–D). Generally, the highest species richness was predicted in topographically complex areas such as the mountains to the east of the Isthmus of Tehuantepec including the Sierra Madre de Chiapas, the mountain ranges extending from the Cordillera de Tilarán southeast along the Cordillera de Talamanca into Panama’s Cordillera Central, the Andes, and the Venezuelan Guayana. Areas predicted to have highest richness formed a longitudinally broad band in Colombia, encompassing the Chocó region and all three Andean cordilleras, and included both Andean cordilleras in Ecuador. These areas were largely restricted to the eastern Andes in Peru and Bolivia according to most models, with the exception of ad hoc model 4, which predicted high plant richness in the

western portion of the Andes in Peru (Fig. 6C), presumably because this latter model did not include any variable explicitly measuring water availability. All models predicted relatively low richness in central Mexico and Yucatán, Los Llanos of Venezuela, and in the Gran Chaco region of Bolivia, Paraguay, and Argentina. All models also predicted a species richness trough in lowland Amazonia relative to S Central America, the Andes, and the Venezuelan Guayana. These predicted patterns of relative plant richness should be seen in the light of important differences between observed and predicted richness values. Specifically, even the models best supported by the data accounted for relatively small portions of the variation in the response variable ($R^2 = 0.258$ – 0.326 ; Tables 1, 2).

Table 3. Pearson’s correlation coefficients among variables used in regression models representing the species energy and spatial heterogeneity hypotheses.

	Area	PET	WD	Temp	Precip	mPET	Elev	Range	Soil	Pawc	PCA1
PET	0.352	1.000									
WD	0.234	0.121	1.000								
Temp	0.301	0.489	0.155	1.000							
Precip	0.184	0.448	0.518	0.392	1.000						
mPET	0.321	0.611	0.123	0.775	0.536	1.000					
Elev	0.137	0.070	0.282	0.596	0.121	0.382	1.000				
Range	0.172	0.061	0.261	0.563	0.118	0.375	0.951	1.000			
Soil	0.256	0.084	0.050	0.055	0.145	0.121	0.069	0.061	1.000		
Pawc	–0.095	0.058	0.129	–0.083	–0.013	0.060	0.055	0.033	0.545	1.000	
PCA1	0.073	0.020	0.220	–0.444	0.031	–0.261	0.838	0.799	0.161	0.112	1.000
Rich	0.166	0.149	–0.146	–0.094	0.301	0.105	0.399	0.346	0.130	0.008	0.401

Area, log10 area; PET, potential evapotranspiration; WD, water deficit; Temp, annual mean temperature; Precip, annual precipitation; mPET, minimum monthly potential evapotranspiration; Elev, log10 variance in elevation; Range, ln elevation range; Soil, log10 variance in soil carbon density; Pawc, log10 variance in available water capacity; PCA1, log10 variance in climate’s first principal component; Rich, relative plant richness measured by rarefaction at 500 herbarium specimen records.

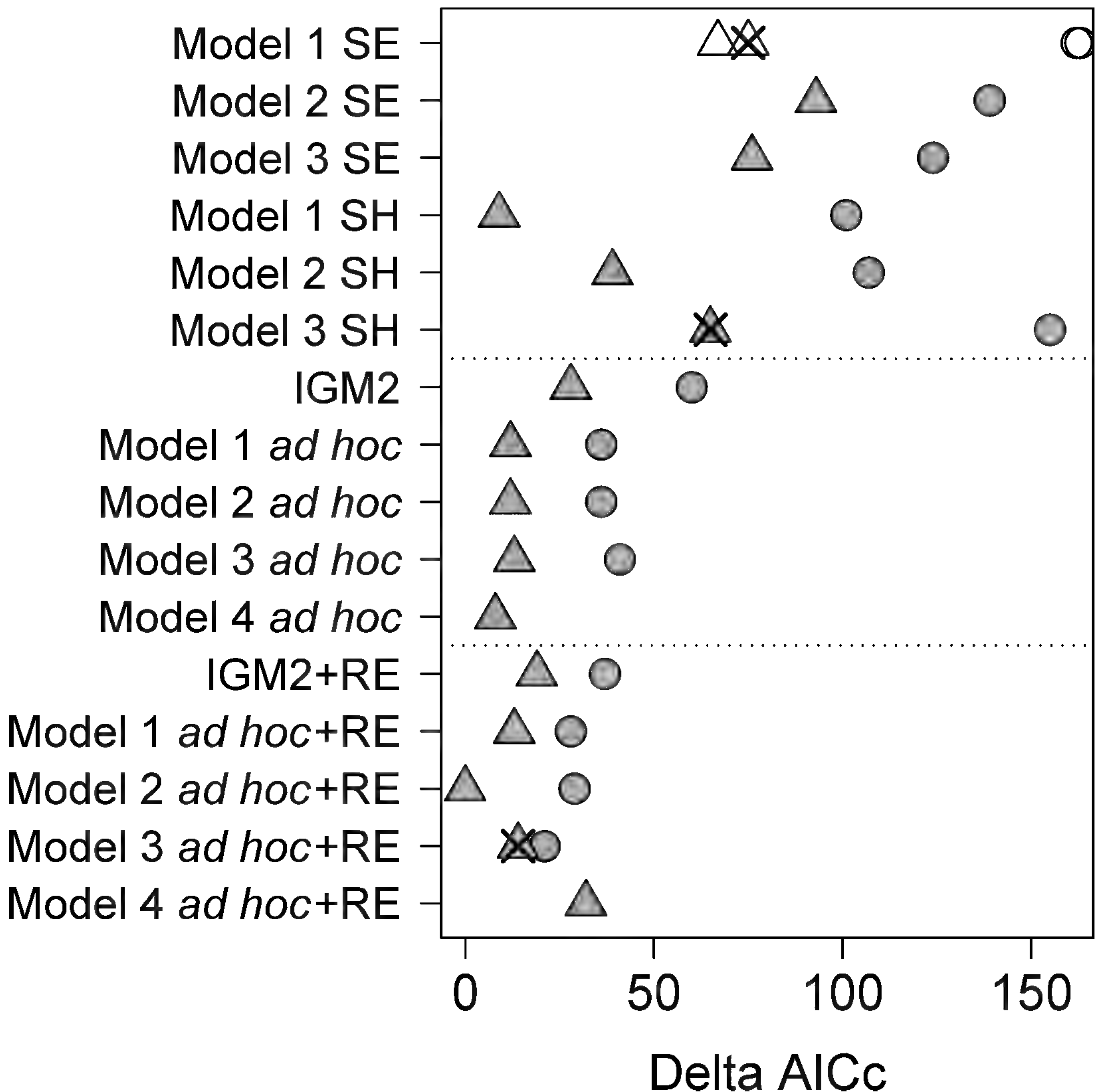

Figure 4. Support for models representing the species energy (SE), spatial heterogeneity (SH), and regional effects (RE) hypotheses estimated by differences in Akaike Information Criterion corrected (AICc) for small sample sizes (delta AICc) between each model and the model performing best (i.e., the model with the lowest AICc). The horizontal dotted lines separate models representing a single hypothesis (top), models combining terms representing the SE and SH (middle), and models combining terms representing the three hypotheses (bottom). Triangles represent spatial models and circles nonspatial models. Filled symbols represent regression models that yielded statistically significant regression coefficients consistent with the respective predictions. Open symbols represent regression models that yielded no statistically significant regression coefficients consistent with the respective predictions. Crosses mark regression models that yielded statistically significant regression coefficients that were inconsistent with the respective predictions. When higher-order terms (interaction or quadratic terms) were not statistically significant, we examined the performance of reduced models with no higher-order terms. Therefore, some models are represented by two circles or triangles.

DISCUSSION

Our results supported most a priori predictions based on previous studies about determinants of plant richness (Currie & Paquin, 1987; Gentry, 1988; O'Brien, 1998; O'Brien et al., 2000; Francis & Currie, 2003; Linder, 2003; Tuomisto et al., 2003; Field et al., 2005; Kreft & Jetz, 2007). Nine of the 13 predictions regarding the sign of regression coefficients relating

plant richness to explanatory variables were supported at least once (potential evapotranspiration and its square, minimum monthly potential evapotranspiration and its square, annual precipitation, within-sampling-unit range in elevation, within-sampling-unit variance in elevation, within-sampling-unit variance in climate, and within-sampling-unit variance in soil carbon density); three predictions were opposed once (annual mean temperature, potential evapotranspiration, and

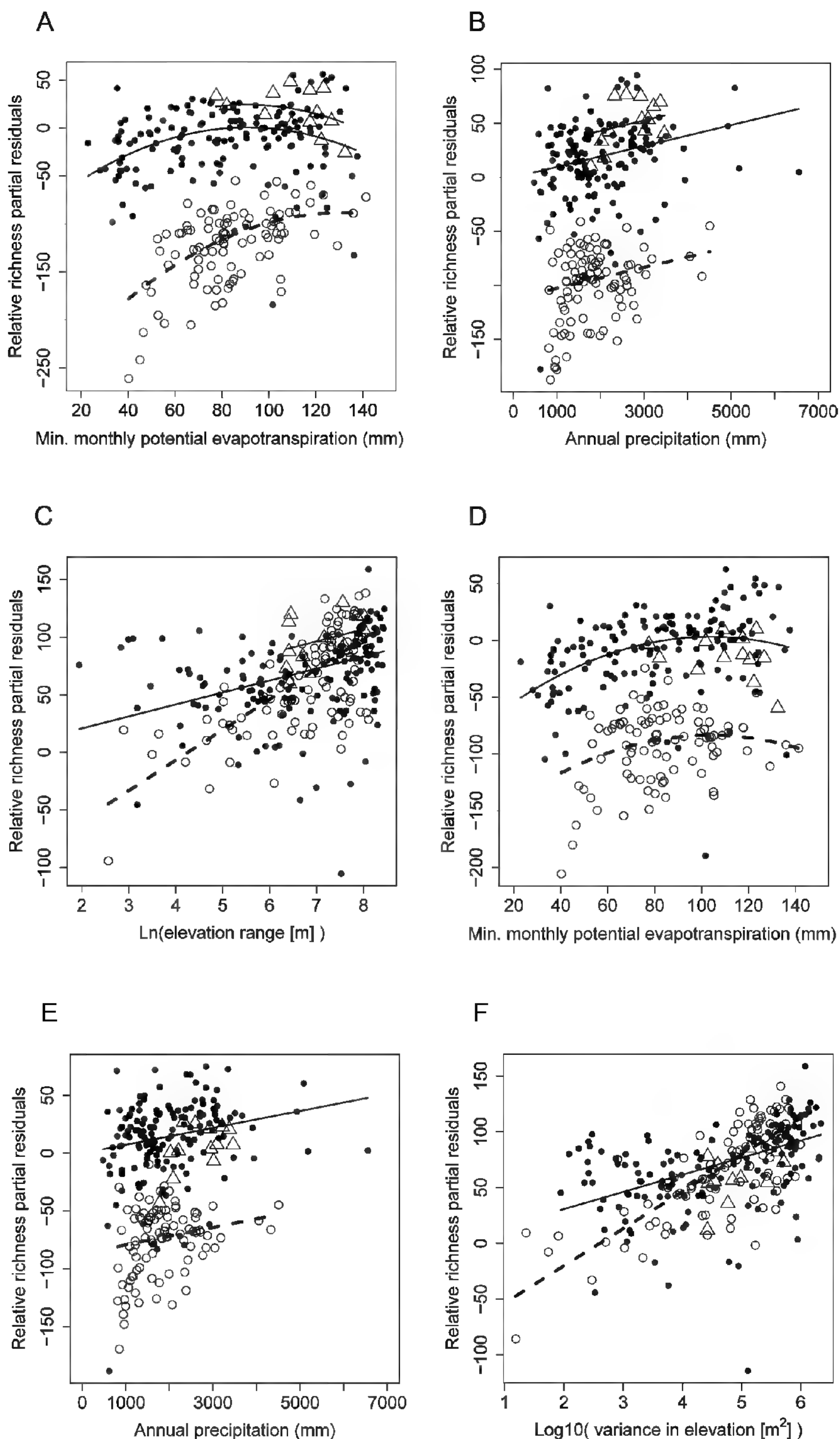

Figure 5. Plots of partial residuals (Draper & Smith, 1998) for models that incorporate the species energy (SE), spatial heterogeneity (SH), and regional effects (RE) hypotheses: —A–C. Nonspatial version of Interim General Model second-generation (IGM2) with regional effects (Table 2). —D–F. Spatial version of ad hoc model 2 with regional effects (see Table 2). These plots show the estimated relationship between relative plant richness and the variable in the abscissa when all other variables in the model are statistically controlled except for regional effects. Open circles (and dashed lines) represent N Central America, open triangles (and solid lines) represent S Central America, and filled circles (and solid lines) represent N South America.

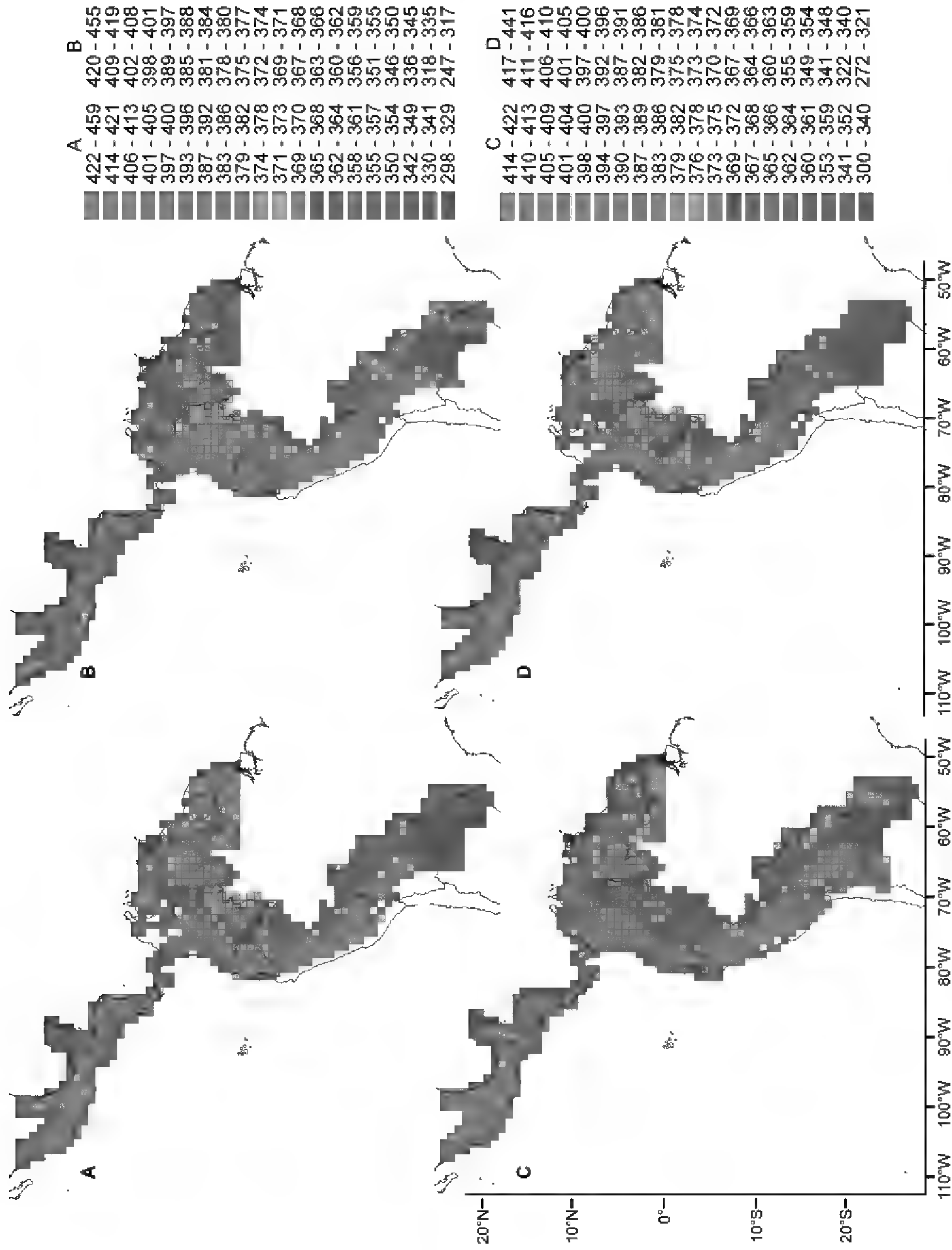

Figure 6. Predicted relative plant richness across the western Neotropics. Each color represents an interval of five percentiles of species richness measured at a resolution of 100×100 km, from high (red) to low (blue). —A. Predicted richness based on the nonspatial version of ad hoc model 2 (Table 1). —B. Predicted richness based on the nonspatial version of ad hoc model 3 with regional effects (Table 2). —C. Predicted richness based on the spatial version of ad hoc model 4 (Table 1). —D. Predicted richness based on the spatial version of ad hoc model 2 with regional effects (Table 2). Prediction is restricted to the sample range of explanatory variables.

within-sampling-unit variance in available water capacity); and two predictions were neither supported nor opposed (water deficit and the interaction between water deficit and annual mean temperature) by statistically significant results (Tables 1, 2). We also found statistically significant differences in relative plant richness among similar environments located in different paleophysiographic regions (Table 2; Fig. 5) defined according to previous work (Graham, 1997; Burnham & Graham, 1999). These findings suggest that we used a reasonable set of hypotheses and corresponding models to examine the relative importance of the major determinants of broad-scale plant richness across the western Neotropics.

The performance of nonspatial and spatial regression models, measured by the consistency of regression coefficients with a priori predictions and by AICc and R^1 values, indicated that explanatory variables representing the SH were the primary determinants of plant richness across the western Neotropics, with complementary contributions from variables representing the SE and, to a lesser extent, the RE. In particular, variance in elevation and variance in climate within sampling units, representing the SH, were the main predictors of the estimated pattern of relative plant richness across the study area. The models performing best overall included variance in elevation and not variance in climate, but distinguishing which of these two variables was more important was difficult because they were highly correlated (Table 3). A third variable representing the SH, variance in soil carbon density within sampling units, was included in some of the best performing models, but its role was secondary to that of variance in elevation or climate. Annual precipitation, minimum monthly potential evapotranspiration, and potential evapotranspiration, representing the SE, most effectively improved the performance of models representing the SH. Here, again, determining whether minimum monthly potential evapotranspiration or potential evapotranspiration was more important was difficult because they were correlated (Table 3). Finally, variables representing the RE sometimes increased the performance of models combining terms representing the SH and SE. Most frequent among these were variables indicating a lower intercept for N Central America than for other regions, a higher intercept for S Central America than for other regions, and higher slopes relating plant richness to spatial heterogeneity within sampling units (variance and range in elevation) and to water (annual precipitation) and energy availability (potential evapotranspiration and minimum monthly potential evapotranspiration) in N Central America than in other regions.

One of the main findings emerging from our analysis was more empirical support for the SH than

for the SE, consistent with a similar study of broad-scale plant richness across northwestern South America that found at least as much support for the SH as for the SE (Jiménez et al., 2009). This result would seem at odds with previous work indicating that variables representing the SE are more important determinants of broad-scale patterns of plant richness than those representing the SH (Currie & Paquin, 1987; O'Brien et al., 2000; Hawkins et al., 2003; Bjorholm et al., 2005; Field et al., 2005; Moser et al., 2005; Kreft et al., 2006; Kreft & Jetz, 2007). We are aware of only one earlier plant study (Pausas et al., 2003) documenting a primary role for the SH outside our study region. Below, we explore potential explanations for the differences between our results and those from previous studies, related to the characteristics of the response variable and the distribution of the explanatory variables.

Geographic patterns of plant richness measured in small sampling units (e.g., < 1 ha. plots) are sometimes considered broad scale (e.g., Hawkins et al., 2003), but the importance of different hypotheses can be contingent on sampling unit size. For example, the relationship between plant richness and variables representing the SE may be most evident when measured across large sampling units, while other factors may exhibit greater heterogeneity and thus be more important determinants of spatial variation in richness at smaller grains (Whittaker et al., 2001). This would seem to be at least as much of an issue for variables representing the SH. Specifically, the SH proposes that spatial heterogeneity fosters species coexistence across habitats and isolated patches of similar habitat, or that it accelerates speciation rates by increasing opportunities for isolation and ecological divergence. Both of these effects are likely increasingly opposed by dispersal as sampling unit size decreases (cf. Moser et al., 2005). Thus, the relative importance of the SH may increase with sampling unit size, as suggested by studies of bird richness (Rahbek & Graves, 2001; van Rensburg et al., 2002; Hulbert & Haskell, 2003).

Regarding procedures to estimate the response variable, previous studies estimated richness by overlapping geographic range maps (e.g., O'Brien, 1998; Francis & Currie, 2003; Bjorholm et al., 2005), while our estimates are based solely on locality data from herbarium specimens. These two methods may yield different estimates of spatial richness patterns and correspondingly different rankings of the importance of different hypotheses (Hulbert & White, 2005). Because species do not typically occur everywhere within the area delimited by range maps (Rondinini et al., 2006), richness estimates based on range maps may measure richness at a larger grain than estimates based

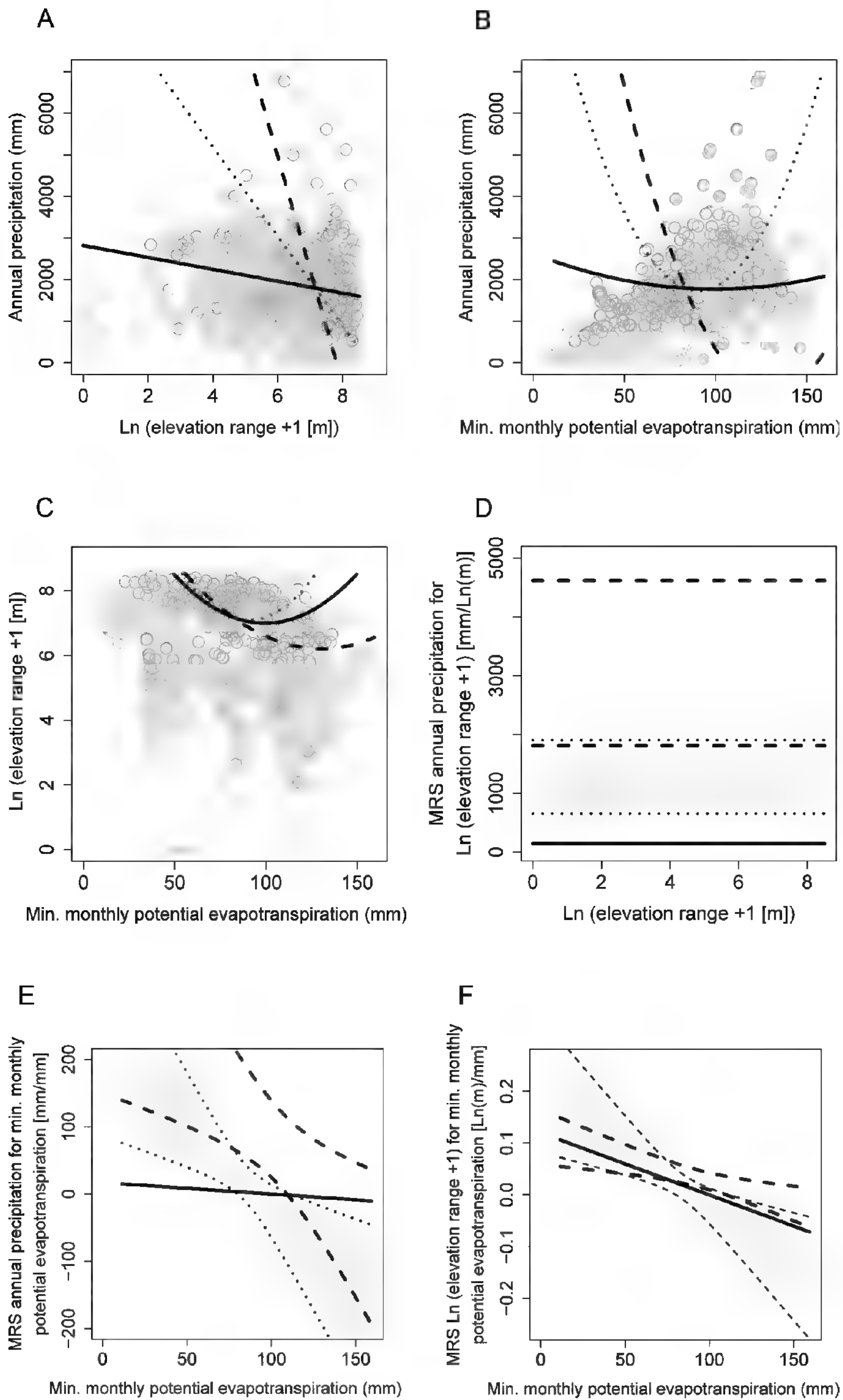

Figure 7. —A, B, C. Predicted plant richness isopleths (lines) in the bivariate distribution of (A) logarithm of elevation range and annual precipitation, (B) minimum monthly potential evapotranspiration and annual precipitation, and (C) minimum monthly potential evapotranspiration and logarithm of elevation range, across the western Neotropics (gray points), showing sampling units included in our sample (gray points with darker outline). The continuous lines are isopleths based on the global coefficients of the Interim General Model second-generation (IGM2). The dashed lines are isopleths for N Central America

on locality data (Hulbert & Jetz, 2007). As such, richness estimates based on range maps may tend to favor variables representing the SH, related to broad-scale species turnover (Hulbert & White, 2005). This expectation, however, is opposite to the difference between our results and those from previous studies.

Another important difference is that between estimates of plant richness based on floras and checklists with no correction for sampling effort (e.g., Kreft & Jetz, 2007), and our estimates based on rarefaction as an attempt to correct for spatial variation in floristic knowledge. Floras and checklists differ not only in their geographic extents, but in the quality of the data and sampling effort across these units (Frodin, 2001; Kier et al., 2005). Such heterogeneity in floristic knowledge can affect estimates of spatial patterns of plant richness and estimates of the importance of different hypotheses. We attempted to account for this heterogeneity using number of specimen records as an estimate of sampling effort (Nelson et al., 1990), assuming that the number of species found in a sampling unit is a function of the number of specimens collected in that sampling unit. Nonetheless, it is possible to imagine scenarios in which the number of specimens collected in a sampling unit is a function of the number of species occurring in that sampling unit. We think the latter is unlikely because plant species inventories of 100×100 km sampling units across our study area are invariably incomplete. Furthermore, the inventory for each sampling unit was derived from several collecting trips that, together, are bound to obtain multiple specimens of species that are common in the sampling unit, even if some plant collectors discriminate against common species.

Studies also differ in the plant life forms on which they focus and, thus, may favor one hypothesis over another because various life forms may respond differently to different factors (Richerson & Lum, 1980; Laanisto et al., 2008). For example, tree species might be less responsive to spatial heterogeneity than nonwoody plant species (Gentry, 1982; Qian & Ricklefs, 2004). However, among studies measuring species richness of both woody and nonwoody life

forms, some conclude that the SE is more important than the SH (Francis & Currie, 2003; Moser et al., 2005; Kreft & Jetz, 2007), while others find the opposite (Pausas et al., 2003; this study). It would be useful for future studies to specifically address this issue by confronting species richness data for different life forms against models representing the SE and SH.

Differences in the central tendency of explanatory variables may also explain why our results differ from those of other studies in terms of the relative importance of the SE and SH. In tropical and subtropical regions, where energy input is high (> 505 mm potential evapotranspiration, Kreft & Jetz, 2007), plant richness may be largely independent of energy and mainly determined by water availability (Hawkins et al., 2003; Whittaker et al., 2006; Kreft & Jetz, 2007) and, to a lesser extent, spatial heterogeneity (Kreft & Jetz, 2007). Despite the fact that potential evapotranspiration values were well above 505 mm in all of our sampling units (Fig. 3), we obtained statistically significant coefficients supporting predictions derived from the SE about how plant richness is related to potential evapotranspiration and minimum monthly potential evapotranspiration (Tables 1, 2; Fig. 5). Thus, our results suggest that both energy and water availability do determine plant richness across the study regions but to a lesser extent than variables representing the SH. Our sample, however, includes few sampling units from some extreme environments in the study regions, particularly those with the lowest annual precipitation (< 1000 mm annual precipitation) and highest water deficit (> 750 mm; Fig. 3). If the effect of annual precipitation or water deficit on plant richness decreases with increasing water availability (Gentry, 1988; Whittaker et al., 2003), our results could have underestimated the importance of water availability and, therefore, the SE.

Differences between our results and those of other studies in the relative importance of the SE and SH may relate to differences in the range of explanatory variables. Compared to studies spanning global extents (Francis & Currie, 2003; Kreft & Jetz, 2007) or aiming to develop global models (Field et al., 2005), the ranges of several variables measuring

←

and the dotted lines for N South America and S Central America, according to the fit of the IGM2 with regional effects to our sample (Table 2). —D, E, F. Marginal rates of substitution (MRS) of annual precipitation for logarithm of elevation range (D), MRS of annual precipitation for minimum monthly potential evapotranspiration (E), and MRS of the logarithm of elevation range for minimum monthly potential evapotranspiration (F). The dashed lines represent 95% confidence intervals of the MRSs for N Central America and the dotted lines (and gray shading) for N South America and S Central America. These confidence intervals are based on parametric bootstrap samples (Efron & Tibishirani, 1993) of size 1,000,000, assuming a multivariate normal distribution of the regression coefficients with the variance-covariance matrix estimated from fitting the IGM2 to our sample. The continuous lines represent the MRSs based on the global coefficients of the IGM2 and have no error estimates because the variance-covariance matrix for such coefficients was not available.

energy and water availability in our sample were small (Fig. 3). Therefore, we may have underestimated the importance of the SE because the proportion of the variation in a response variable (e.g., relative plant richness) accounted for by an explanatory variable (e.g., mean annual temperature) can be a function of the sample range of the latter (Pedhazur, 1997). By the same token, in our sample, the range of a variable representing the SH, elevation range within sampling units, was similar to the sample range of a study of global extent (Kreft & Jetz, 2007) and larger than that of a study aiming to develop global models (Field et al., 2005; Fig. 3). Thus, the latter study may have underestimated the importance of the SH. If our sample is representative of the variation in energy and water availability across our study area (Fig. 3), the conclusion of more empirical support for the SH than for the SE would still be valid for this area.

We found significant regional effects among N Central America, S Central America, and N South America, consistent with studies that have explicitly tested for, and commonly found, evidence supporting the RE (Schluter & Ricklefs, 1993; Ricklefs, 2004; Kreft & Jetz, 2007). Identifying the underlying causes of differences in plant richness attributed to regional effects can be difficult, because they can actually reflect differences in environmental variables not accounted for (Schluter & Ricklefs, 1993). However, two of the most prominent regional effects that we obtained were consistent with previous assessments of historical influences on Neotropical plant diversity (Gentry, 1982). First, the lower intercept for N Central America than for other regions may be due to limited northward movement of Gondwanan clades that compose most Neotropical plant diversity in the lowlands (i.e., Amazonian-centered taxa sensu Gentry, 1982). Second, a steeper slope relating plant richness to spatial heterogeneity in N Central America than in other regions may be due to limited southward movement of Laurasian clades that are more important components of montane than lowland Neotropical floras (Gentry, 1982). Laurasian clades may then contribute more to the increase in richness associated with spatial heterogeneity in N Central America than in S Central America and N South America.

Last, we discuss implications of our findings for the perception of the spatial pattern of plant richness across the western Neotropics. Our analysis predicted peaks of relative species richness mostly in topographically complex areas (Figs. 2C, 6), consistent with a similar analysis for northwest South America (Jiménez et al., 2009) and another recent mapping effort (Kreft & Jetz, 2007: fig 3b), but contrasting with maps showing higher vascular plant richness in lowland areas than in the northern Andes (Barthlott

et al., 2005; Mutke & Barthlott, 2005; Kreft & Jetz, 2007: fig. 3c, d). The latter maps are similar to the pattern predicted by global coefficients for the IGM2 (Fig. 2D), designed for estimating broad-scale richness of woody plants worldwide (Field et al., 2005). Below, we suggest a potential explanation for the contrast between different plant richness maps of the Neotropics, based on differences between the global coefficients of the IGM2 (Fig. 2D) and the coefficients yielded by fitting the IGM2 to our sample (Fig. 2C).

The contrast between the map of predicted plant richness based on global coefficients of the IGM2 (Fig. 2D) and that based on the fit of the IGM2 to our sample (Fig. 2C) is underlain by a difference in the importance of the logarithm of elevation range relative to annual precipitation. This is illustrated by isopleths showing combinations of logarithm of elevation range and annual precipitation that, according to a given model and holding other variables constant, yield a constant predicted richness value (Fig. 7A). The slope of the isopleths based on our sample are more negative than the slope of the isopleth based on the global coefficients of the IGM2, suggesting that the importance of the logarithm of elevation range relative to annual precipitation is higher in the fit of the IGM2 to our data than in the global coefficients of the IGM2. This difference is quantified by the marginal rate of substitution (MRS; Caraco, 1979; Brown, 1988) of annual precipitation for the logarithm of elevation range, which corresponds to the negative of the slope of the isopleths in Figure 7A and measures the amount of annual precipitation needed to substitute a logarithmic unit of elevation range and maintain the same species richness in any given sampling unit (see appendix S1 note A in Jiménez et al., 2009). The MRS of annual precipitation for the logarithm of elevation range is higher in the fit of the IGM2 to our data than in the global coefficients of the IGM2 (Fig. 7D).

The foregoing contrast between the maps of predicted plant richness (Fig. 2C vs. D) also results from differences in the relative importance of minimum monthly potential evapotranspiration and annual precipitation. This can be seen in isopleths showing combinations of values of minimum monthly potential evapotranspiration and annual precipitation that, holding other variables constant, yield a constant predicted richness value (Fig. 7B). These isopleths bend because, according to the IGM2, the relationship between minimum monthly potential evapotranspiration and plant richness is quadratic (e.g., Fig. 5A). The negative of the slope of these isopleths is the MRS of annual precipitation for minimum monthly potential evapotranspiration. It measures the amount of annual precipitation needed to substitute a small increase in minimum monthly potential evapotranspiration and

maintain the same species richness in any given sampling unit. This MRS decreases as minimum monthly potential evapotranspiration increases (Fig. 7E) because, as pointed out previously, according to the IGM2 the relationship between minimum monthly potential evapotranspiration and plant richness is quadratic. As minimum monthly potential evapotranspiration increases, the decrease in the MRS of annual precipitation for minimum monthly potential evapotranspiration is steeper in the fit of the IGM2 to our data than in the global coefficients of the IGM2 (Fig. 7E). This finding suggests that the importance of minimum monthly potential evapotranspiration relative to annual precipitation is higher in the fit of the IGM2 to our sample than in the global coefficients of the IGM2.

Finally, the contrast between the map of predicted plant richness derived from global coefficients of the IGM2 (Fig. 2D) and that derived from the coefficients yielded by fitting the IGM2 to our sample (Fig. 2C) does not seem to reflect differences in the importance of the logarithm of elevation range relative to minimum monthly potential evapotranspiration. This notion is suggested by isopleths showing combinations of values of logarithm of elevation range and minimum monthly potential evapotranspiration that, holding other variables constant, yield a constant predicted richness value (Fig. 7C). These isopleths bend because the IGM2 portrays a quadratic relationship between minimum monthly potential evapotranspiration and plant richness. The negative of the slope of these isopleths is the MRS of logarithm of elevation range for minimum monthly potential evapotranspiration, and measures the elevation range (in logarithmic units) needed to substitute a small increase in minimum monthly potential evapotranspiration and maintain the same species richness in any given sampling unit. Along the axis of minimum monthly potential evapotranspiration, the MRS of logarithm of elevation range for minimum monthly potential evapotranspiration derived from the fit of the IGM2 to our data overlaps with that derived from the global coefficients of the IGM2 (Fig. 7F). This finding indicates that the importance of the logarithm of elevation range relative to minimum monthly potential evapotranspiration is similar in both cases.

The comparisons above suggest that differences among representations of plant richness across the Neotropics may result from differences in estimates of the relative importance of three main determinants of plant richness. Relative to maps showing higher vascular plant richness in lowland areas than topographically complex areas, our maps of predicted richness may assign a larger role to elevation range and minimum monthly potential evapotranspiration than to annual precipitation.

Literature Cited

- Ahn, C. H. & R. Tateishi. 1994. Development of global 30-minute grid potential evapotranspiration data set. *J. Jap. Soc. Photogrammetry Remote Sensing* 33: 12–21.
- Barthlott, W., J. Mutke, D. Rafiqpoor, G. Kier & H. Kreft. 2005. Global centers of vascular plant diversity. *Nova Acta Leop.* 342: 61–83.
- Bivand, R. 2008. *spdep: Spatial dependence: weighting schemes, statistics and models, version 0.4–20.* <<http://cran.r-project.org/web/packages/spdep/index.html>>, accessed 25 June 2008.
- Bjorholm, S., J. C. Svenning, F. Skov & H. Balslev. 2005. Environmental and spatial controls of palm (Arecaceae) species richness across the Americas. *Global Ecol. Biogeogr.* 14: 423–429.
- Brown, J. H. 1981. Two decades of homage to Santa Rosalia: Toward a general theory of diversity. *Amer. Zool.* 21: 877–888.
- Brown, J. S. 1988. Patch use as an indicator of habitat preference, predation risk, and competition. *Behav. Ecol. Sociobiol.* 22: 37–47.
- Burnham, K. P. & D. R. Anderson. 2002. *Model Selection and Multimodel Inference: A Practical Information-Theoretic Approach.* Springer, New York.
- Burnham, R. J. & A. Graham. 1999. The history of neotropical vegetation: New developments and status. *Ann. Missouri Bot. Gard.* 86: 546–589.
- Cade, B. S., B. R. Noon & C. H. Flather. 2005. Quantile regression reveals hidden bias and uncertainty in habitat models. *Ecology* 86: 786–800.
- Caraco, T. 1979. Time budgeting and group size: A theory. *Ecology* 60: 611–617.
- Chatterjee, S. & A. S. Hadi. 1988. *Regression Analysis by Example.* Wiley, Hoboken, New Jersey.
- Clarke, A. & K. J. Gaston. 2006. Climate, energy, and diversity. *Proc. Roy. Soc. London, Ser. B, Biol. Sci.* 273: 2257–2266.
- Crawley, M. J. 2002. *Statistical Computing.* Wiley, New York.
- Currie, D. J. & V. Paquin. 1987. Large scale biogeographical patterns of species richness of trees. *Nature* 329: 326–327.
- , G. G. Mittelbach, H. V. Cornell, R. Field, J. F. Guégan, B. A. Hawkins, D. A. Kaufman, J. T. Kerr, T. Oberdorff, E. M. O'Brien & J. R. G. Turner. 2004. Predictions and tests of climate-based hypotheses of broad-scale variation in taxonomic richness. *Ecol. Lett.* 7: 1121–1134.
- Darwin, C. 1862. *The Voyage of the Beagle.* Doubleday, Garden City, New York.
- Dormann, C. F., J. M. McPherson, M. B. Araújo, R. Bivand, J. Bolliger, G. Carl, R. G. Davies, A. Hirzel, W. Jetz, W. D. Kissling, I. Kühn, R. Ohlemüller, P. R. Peres-Neto, B. Reineking, B. Schröder, F. M. Schurr & R. Wilson. 2007. Methods to account for spatial autocorrelation in the analysis of species distributional data: A review. *Eco-geography* 30: 609–628.
- Draper, N. R. & H. Smith. 1998. *Applied Regression Analysis.* Wiley, New York.
- Efron, B. & R. Tibishirani. 1993. *An Introduction to the Bootstrap.* Chapman & Hall/CRC Press, New York.
- Evans, K. L., P. H. Warren & K. J. Gaston. 2005. Species-energy relationships at the macroecological scale: A review of the mechanisms. *Biol. Rev.* 80: 1–25.
- & K. J. Gaston. 2005. Can the evolutionary-rates hypothesis explain species-energy relationships? *Funct. Ecol.* 19: 899–915.

- Field, R., E. M. O'Brien & R. J. Whittaker. 2005. Global models for predicting woody plant richness from climate: Development and evaluation. *Ecology* 86: 2263–2277.
- Fortin, M. J. & M. Dale. 2005. *Spatial Analysis for Ecologists*. Cambridge University Press, Cambridge.
- Francis, A. P. & D. J. Currie. 2003. A globally consistent richness-climate relationship for angiosperms. *Amer. Naturalist* 161: 523–536.
- Frodin, D. G. 2001. Floras in retrospect and for the future. *Pl. Talk* 25: 36–39.
- Gaston, K. J. 2000. Global patterns in biodiversity. *Nature* 405: 220–227.
- Gentry, A. H. 1982. Neotropical floristic diversity: Phyto-geographical connections between Central and South America, Pleistocene climatic fluctuations, or an accident of the Andean orogeny? *Ann. Missouri Bot. Gard.* 69: 557–593.
- . 1988. Changes in plant community diversity and floristic composition on environmental and geographical gradients. *Ann. Missouri Bot. Gard.* 75: 1–34.
- Global Soil Data Task. Global Soil Data Products CD-ROM (IGBP-DIS). International geosphere-biosphere programme data and information services. <<http://www.daac.ornl.gov>>, accessed 15 June 2006.
- Gotelli, N. J. & R. K. Colwell. 2001. Quantifying biodiversity: Procedures and pitfalls in the measurement and comparison of species richness. *Ecol. Lett.* 4: 379–391.
- Graham, A. 1997. Neotropical plant dynamics during the Cenozoic—Diversification and the ordering of evolutionary and speciation processes. *Syst. Bot.* 22: 139–150.
- Hawkins, B. A. 2001. Ecology's oldest pattern? *Trends Ecol. Evol.* 16: 470.
- , R. Field, H. V. Cornell, D. J. Currie, J. F. Guégan, D. M. Kaufman, J. T. Kerr, T. O. Mittelback, E. M. O'Brien, E. E. Porter & J. R. G. Turner. 2003. Energy, water, and broad-scale geographic patterns of species richness. *Ecology* 84: 3105–3117.
- Hijmans, R. J., S. E. Cameron, J. L. Parra, P. G. Jones & A. Jarvis. 2005. Very high resolution interpolated climate surfaces for global land areas. *Int. J. Climatol.* 2: 1965–1968.
- Hulbert, A. H. & J. P. Haskell. 2003. The effect of energy and seasonality on avian species richness and community composition. *Amer. Naturalist* 161: 83–97.
- & E. P. White. 2005. Disparity between range map- and survey-based analyses of species richness: Patterns, processes and implications. *Ecol. Lett.* 8: 319–327.
- & W. Jetz. 2007. Species richness, hotspots, and the scale dependence of range maps in ecology and conservation. *Proc. Natl. Acad. U.S.A.* 104: 13384–13389.
- Huston, M. 1979. A general hypothesis of species diversity. *Amer. Naturalist* 113: 8–101.
- . 1994. *Biological Diversity: The Coexistence of Species on Changing Landscapes*. Cambridge University Press, Cambridge.
- Hutchinson, G. E. 1959. Homage to Santa Rosalia or why are there so many kinds of animals? *Amer. Naturalist* 93: 145–159.
- Jetz, W., C. Rahbek & R. K. Colwell. 2004. The coincidence of rarity and richness and the potential signature of history in centers of endemism. *Ecol. Lett.* 7: 1180–1191.
- Jiménez, I., T. Distler & P. Jørgensen. 2009. Estimated plant richness pattern across northwest South America provides similar support for the species-energy and spatial heterogeneity hypotheses. *Ecography* 32: 433–448.
- Kier, G., J. Mutke, E. Dinerstein, T. H. Ricketts, W. Kuper, H. Kreft & W. Barthlott. 2005. Global patterns of plant diversity and floristic knowledge. *J. Biogeogr.* 32: 1107–1116.
- Koenker, R. 2005. *Quantile Regression: Econometric Society Monographs*. Cambridge University Press, Cambridge.
- . 2008. *Quantile Regression and Related Methods*. <<http://cran.r-project.org/web/packages/quantreg/index.html>>, accessed 25 June 2008.
- Kreft, H. & W. Jetz. 2007. Global patterns and determinants of vascular plant diversity. *Proc. Natl. Acad. U.S.A.* 104: 5925–5930.
- , J. H. Sommer & W. Barthlott. 2006. The significance of geographic range size for spatial diversity patterns in Neotropical plants. *Ecography* 29: 21–30.
- Laanisto, L., P. Urbas & M. Partel. 2008. Why does the unimodal species richness-productivity relationship not apply to woody species: A lack of clonality or a legacy of tropical evolutionary history? *Global Ecol. Biogeogr.* 17: 320–326.
- Latham, R. E. & R. E. Ricklefs. 1993. Continental comparisons of temperate zone tree species diversity. Pp. 294–314 *in* R. E. Ricklefs & D. Schulter (editors), *Species Diversity in Ecological Communities*. University of Chicago Press, Chicago.
- Linder, H. P. 2003. The radiation of the Cape flora, southern Africa. *Biol. Rev.* 78: 597–638.
- Missouri Botanical Garden. Tropicos. <<http://www.tropicos.org>>, accessed 15 November 2006.
- Moser, D., S. Dullinger, T. Englisch, H. Niklfeld, C. Plutzer, N. Sauberer, H. G. Zechmeister & G. Grabherr. 2005. Environmental determinants of vascular plant species richness in the Austrian Alps. *J. Biogeogr.* 32: 1117–1127.
- Mutke, J. & W. Barthlott. 2005. Patterns of vascular plant diversity at continental to global scales. *Biol. Skr.* 55: 521–531.
- Nelson, B. W., C. A. Ferreira, M. F. da Silva & M. L. Kawasaki. 1990. Endemism centres, refugia and botanical collection density in Brazilian Amazonia. *Nature* 345: 714–716.
- O'Brien, E. M. 1993. Climatic gradients in woody plant species richness: Towards an explanation based on an analysis of southern Africa's woody flora. *J. Biogeogr.* 20: 181–198.
- . 1998. Water-energy dynamics, climate, and prediction of woody plant species richness: An interim general model. *J. Biogeogr.* 25: 379–398.
- , R. Field & R. J. Whittaker. 2000. Climatic gradients in woody plant (tree and shrub) diversity: Water-energy dynamics, residual variation, and topography. *Oikos* 89: 588–600.
- Palmer, M. L. 1994. Variation in species richness: Towards a unification of hypotheses. *Folia Geobot.* 29: 511–530.
- Parnell, J. A. N., D. A. Simpson, J. Moat, D. W. Kirkup, P. Chantaranonthai, P. C. Boyce, P. Bygrave, S. Dransfield, M. H. P. Jebb, J. Macklin, C. Meade, D. J. Middleton, A. M. Muasya, A. Prajaksood, C. A. Pendry, R. Pooma, S. Suddee & P. Wilkin. 2003. Plant collecting spread and densities: Their potential impact on biogeographical studies in Thailand. *J. Biogeogr.* 30: 193–209.
- Pausas, J. G., J. Carreras, A. Ferré & X. Font. 2003. Coarse-scale plant species richness in relation to environmental heterogeneity. *J. Veg. Sci.* 14: 661–668.
- Pedhazur, E. J. 1997. *Multiple Regression in Behavioral Research: Explanation and Prediction*. Harcourt Brace College Publishers, Fort Worth.

- Pennisi, E. 2005. What determines species diversity? *Science* 309: 90.
- Pianka, E. R. 1966. Latitudinal gradients in species diversity: A review of concepts. *Amer. Naturalist* 100: 33–46.
- Qian, H. & R. E. Ricklefs. 2000. Large-scale processes and the Asian bias in temperate plant species diversity. *Nature* 407: 180–182.
- & ———. 2004. Geographical distribution and ecological conservatism of disjunct genera of vascular plants in eastern Asia and eastern North America. *J. Ecol.* 92: 253–265.
- Quinn, G. P. & M. J. Keough. 2003. *Experimental design and data analyses for biologists*. Cambridge University Press, Cambridge.
- R Development Core Team. 2006. *R: A Language and Environment for Statistical Computing*. R Foundation for Statistical Computing, Vienna, Austria; Vienna University of Economics and Business Administration, Vienna. <<http://www.R-project.org>>, accessed 25 June 2008.
- Rahbek, C. & G. R. Graves. 2001. Multiscale assessment of patterns of avian species richness. *Proc. Natl. Acad. U.S.A.* 98: 4534–4539.
- Richerson, P. J. & K. Lum. 1980. Patterns of plant species diversity in California: Relation to weather and topography. *Amer. Naturalist* 116: 504–536.
- Ricklefs, R. E. 2004. A comprehensive framework for global patterns in biodiversity. *Ecol. Lett.* 7: 1–15.
- , H. Qian & P. S. White. 2004. The region effect on mesoscale plant species richness between eastern Asia and eastern North America. *Ecography* 27: 129–136.
- Rohde, K. 1992. Latitudinal gradients in species diversity: The search for the primary cause. *Oikos* 65: 514–527.
- Rondinini, C., K. A. Wilson, L. Biotani, H. Grantham & H. P. Possingham. 2006. Tradeoffs of different types of species occurrence data for use in systematic conservation planning. *Ecol. Lett.* 9: 1136–1145.
- Rosenzweig, M. L. 1995. *Species Diversity in Space and Time*. Cambridge University Press, Cambridge.
- Schemske, D. W. 2002. Ecological and evolutionary perspectives on the origins of tropical diversity. Pp. 163–173 *in* R. Chazdon & T. Whitmore (editors), *Foundations of Tropical Forest Biology: Classic Papers with Commentaries*. University of Chicago Press, Chicago.
- Schluter, D. & R. E. Ricklefs. 1993. Convergence and the regional component of species diversity. Pp. 230–242 *in* R. E. Ricklefs & D. Schluter (editors), *Species Diversity in Ecological Communities: Historical and Geographical Perspectives*. University of Chicago Press, Chicago.
- Simpson, G. G. 1964. Species density of North American recent mammals. *Syst. Zool.* 13: 57–73.
- Thornthwaite, C. W. 1948. An approach toward a rational classification of climate. *Geogr. Rev.* 38: 55–94.
- Tuomisto, H., K. Ruokolainen & M. Yli-Halla. 2003. Dispersal, environment, and floristic variation of western Amazonian forests. *Science* 299: 241–244.
- Turner, J. R. G., C. M. Gatehouse & C. A. Corey. 1987. Does solar energy control organic diversity? Butterflies, moths and the British climate. *Oikos* 48: 195–205.
- U.S. Geological Survey. 2004. Reprocessed by the GLCF (1,3,30) Arc second SRTM elevation, reprocessed to GeoTIFF, Version 1.0. USGS, Global Land Cover Facility, College Park, Maryland. <<http://glcf.umd.edu/data/srtm>>, accessed 15 June 2008.
- van Rensburg, B. J., S. L. Chown & K. J. Gaston. 2002. Species richness, environmental correlates, and spatial scale: A test using South African birds. *Amer. Naturalist* 159: 566–577.
- von Humboldt, A. 1808. *Ansichten der Natur mit wissenschaftlichen Erläuterungen*. J. G. Cotta, Tübingen, Germany.
- Wallace, A. R. 1878. *Tropical Nature and Other Essays*. Macmillan, New York and London.
- Whittaker, R. J., K. J. Willis & R. Field. 2001. Scale and species richness: Towards a general, hierarchical theory of species diversity. *J. Biogeogr.* 28: 453–470.
- , ——— & ———. 2003. Climatic-energetic explanations of diversity: A macroscopic perspective. Pp. 107–129 *in* T. M. Blackburn & K. J. Gaston (editors), *Macroecology: Concepts and Consequences*. Cambridge University Press, Cambridge.
- , M. B. Araújo, P. Jepsen, R. J. Ladle, J. E. M. Watson & K. J. Willis. 2005. Conservation biogeography: Assessment and prospect. *Diversity Distrib.* 11: 3–23.
- , D. Nogués-Bravo & M. B. Araújo. 2006. Geographical gradients of species richness: A test of the water-energy conjecture of Hawkins et al. (2003) using European data for five taxa. *Global Ecol. Biogeogr.* 16: 76–89.
- Willig, M. R., D. M. Kaufman & R. D. Stevens. 2003. Latitudinal gradients of biodiversity: Process, scale, and synthesis. *Annual Rev. Ecol. Syst.* 34: 273–309.
- Wolman, A. G. 2006. Measurement and meaningfulness in conservation science. *Conservation Biol.* 20: 1626–1634.
- Wright, D. H. 1983. Species-energy theory: An extension of species area theory. *Oikos* 41: 496–506.
- Wulff, E. W. 1935. Versuch einer Einteilung der Vegetation der Erde in pflanzengeographische Gebiete auf Grund der Artenzahl. *Repert. Spec. Nov. Regni Veg.* 12: 57–83.

ANDEAN LAND USE AND BIODIVERSITY: HUMANIZED LANDSCAPES IN A TIME OF CHANGE

*Kenneth R. Young*¹

ABSTRACT

Some landscapes cannot be understood without references to the kinds, degrees, and history of human-caused modifications to the Earth's surface. The tropical latitudes of the Andes represent one such place, with agricultural land-use systems appearing in the Early Holocene. Current land use includes both intensive and extensive grazing and crop- or tree-based agricultural systems found across virtually the entire range of possible elevations and humidity regimes. Biodiversity found in or adjacent to such humanized landscapes will have been altered in abundance, composition, and distribution in relation to the resiliency of the native species to harvest, land cover modifications, and other deliberate or inadvertent human land uses. In addition, the geometries of land cover, resulting from differences among the shapes, sizes, connectivities, and physical structures of the patches, corridors, and matrices that compose landscape mosaics, will constrain biodiversity, often in predictable ways. This article proposes a conceptual model that implies that the continued persistence of native species may depend as much on the shifting of Andean landscape mosaics as on species characteristics themselves. Furthermore, mountains such as the Andes display long gradients of environmental conditions that alter in relation to latitude, soil moisture, aspect, and elevation. Global environmental change will shift these, especially temperature and humidity regimes along elevational gradients, causing changes outside the historical range of variation for some species. Both land-use systems and conservation efforts will need to respond spatially to these shifts in the future, at both landscape and regional scales.

Key words: Andes, climate change, human impact, land use, land use/land cover change, landscape ecology.

Humankind has lived on the Earth, and thus altered parts of it, for millennia—in the case of the Old World, for several million years. In such long-inhabited landscapes, the nature of the influence of people through their land uses on native plants and animals, and on the living land cover provided by vegetation, is important to evaluate. For example, it matters greatly if deforestation began 40 years ago due to the entrance of colonists with chain saws, or if current land cover modifications are in fact affecting a landscape reforested following a previous but ancient forest clearance. Often, detailed historical information on past land use will not be readily available, but an awareness of possible consequences is feasible, desirable, and useful for calibrating efforts for biodiversity conservation and for planning for resource sustainability. This article begins to assemble the information needed to prepare for the consequences of changed future environments in the Andean landscapes.

The conservation of biodiversity has spatial dimensions that range from global concerns to the genes of particular subspecies, land races, or individuals. This multiscale quintessence results from the fact that biodiversity (biological diversity) includes not only species but the populations and genetic systems that underlie those species, in addition to multispecies

assemblages, communities, and ecosystems (Noss, 1990; Franklin, 1993). A scale, and also an organizational level, of particular relevance to land use and to inhabited places in general is that of the landscape, typically taken in this context to refer to an area of the Earth's surface tens to several hundreds of square kilometers in size (Turner, 2005). This article examines Andean landscapes where that amount of surface area includes the size range that accommodates the dimensions of landscapes used by a particular owner, family, community, or organization. In addition, landscapes are at a human scale with which to observe, organize, and conceptualize the Earth's surface, as seen, e.g., in the prevalence of landscape photographs and paintings. Landscape ecology provides a conceptual framework, a vocabulary, and a set of paradigmatic expectations that can be used to classify and quantify the shifting of land cover types in a particular place (Young & Aspinall, 2006).

This article uses a landscape approach to consider some of the implications of human impacts, current and past, in the Andes. It begins with an overview of how the Earth's surface can be evaluated in terms of landscape mosaics (Forman, 1995), especially in mountainous regions, taking examples from other places in the world when the relevant studies have yet

¹ Department of Geography and the Environment, University of Texas, Austin, Texas 78712, U.S.A. kryoung@austin.utexas.edu.

doi: 10.3417/2008035

to be done in the Andes. Often, a landscape ecology approach is conceptualized strictly in terms of ecological processes, but this article also situates the Andean landscapes within regional and geological contexts, with their respective spatial and temporal scales. It is also important to identify landscape legacies that continue to alter biophysical conditions for species today (cf. Foster et al., 2003). These legacies and current land-use practices contribute to humanizing parts of the Andes, remade into utilized and inhabited spaces (Troll, 1968; Ellenberg, 1979). Finally, this information is used to propose a conceptual model of what kinds of places and what kinds of species are most threatened with future extinctions—a topic of considerable importance for the Andes, where species loss is occurring (Pitman et al., 2002; Pounds et al., 2006).

LANDSCAPE ECOLOGY IN THE ANDES

Land cover varies from place to place in ways that can be measured, mapped, and modeled. In a given Andean landscape, or indeed for most any terrestrial landscape, underlying environmental heterogeneity in soil characteristics such as moisture, depth, and chemistry can alter the species composition, density, and life forms of plants dominating local tracts of vegetation (e.g., Clark et al., 1998; Svenning, 2001), in addition to the associated soil biota and edaphic processes (Wardle, 2002; Vanbergen et al., 2007). Over slightly larger extents, there will be streams, ponds, or rock outcrops that form or support differing substrates that add additional spatial heterogeneity to land cover (e.g., Ibarra-Manríquez & Martínez-Ramos, 2002; Dwire et al., 2004). Disturbances, as minor as those caused by the falling of limbs from a large tree or as intense as fires that burn plants and leaf litter down to mineral soil, create patches of open habitat. Destructive storms can have landscape consequences over regions subjected to freezing rain (Stueve et al., 2007); volcanoes can set the biophysical features that then control post-disturbance vegetation and ecosystem processes (Vitousek, 2004). Those open sites can be colonized by plant species that are easily dispersed or that grow in quickly from gap edges.

Disturbance gaps that result from the physical removal of land cover and the biogeochemical alteration of perturbed sites allow a variety of fugitive, successional, and other species to survive in a given landscape (Wilcox et al., 2006). Plant diseases similarly both move in response to spatial heterogeneity and also help to create and maintain heterogeneity (Plantegenest et al., 2007). Disturbance and successional dynamics thus act upon the living land covers formed by native vegetation types, creating

landscape mosaics that can be characterized in terms of changes along spatial gradients in underlying biophysical constraints, in addition to the dynamism imposed by plant death and regrowth (e.g., Velázquez & Gómez-Sal, 2007).

Important coupled feedbacks tie in other trophic levels that can act to reinforce landscape spatial heterogeneity or, alternatively, to lessen it. Herbivores, for example, may remove much biomass of palatable species, altering dominance or even shifting one vegetation type to another (e.g., Dorrough et al., 2007). Often, plant species growing in a disturbance-caused gap lack the plethora of herbivore defenses found in undisturbed sites (Coley & Barone, 1996), so herbivore impact is spatially heterogeneous in itself (e.g., Forester et al., 2007). The same would be true of the degree and influence of mutualistic relationships such as those between flowering plants and their pollinators (e.g., Muchhala & Jarrín-V., 2002) or between plants with fruits attractive to birds, monkeys, or bats and their vertebrate dispersers (Palacios & Rodríguez, 2001; Rodríguez-Cabal et al., 2007). Predators can exert top-down influences with landscape consequences (Ripple et al., 2001; Smith et al., 2003; Schmitz, 2008).

Many human impacts leave conspicuous alterations on landscapes, with cover modified into housing, roads, pastures, or tree plantations. Other influences, however, may be more subtle, with forests still dominated by native species, but with the seed dispersers and seed predators rearranged in their abundances by hunting and harvesting: leaving behind what Redford (1992) called empty forests, which, as a result, will have altered future forest successional trajectories. Bodin et al. (2006) showed that even small forest patches in otherwise deforested areas of Madagascar provided important environmental services for local people.

All these features of spatial heterogeneity and landscape dynamism characterize the Andes (Young et al., 2007; Young, 2008). Complete explanations of spatial and temporal change will necessarily need to consider or control for all of these edaphic, vegetational, and ecological processes, in addition to human land use itself. Consider, for example, the landscape in Figure 1. The spatial heterogeneity most visible is imparted by the patchwork of houses and agricultural fields. Because the dominant land cover type includes the different kinds of agricultural fields, this could be called the landscape matrix, with additional patches in that matrix of trees and of the settlement. Clearly, much explanation of the details of this mosaic landscape patterning would require data regarding human decisions on when and where the residents chose to live and decided what to grow. The social



Figure 1. Humanized landscape in the Peruvian Andes showing houses, planted trees, and agricultural fields.

sciences would need to provide many of the research paradigms. However, even this intensively used (humanized) landscape has an important underlying spatial heterogeneity that comes from minor changes in elevation, topography, and soils. Landscape ecology increasingly draws from relevant social, behavioral, and economic theories in providing explanations of patterns and processes.

Global environmental change will alter connectivity among different land cover patches, along environmental gradients, and within the landscapes themselves. Often, species are found in areas much larger than a landscape, so that their overall range distributions will be changed in relation to their environmental tolerances, with cold-adapted species shifted to higher elevations and moisture-requiring species pushed into humid refugia (Golicher et al., 2008). Particular landscapes may be relatively buffered from change. In others, however, species dominance can be expected to change, leading to numerous feedbacks and shifts to and through trophic systems, with consequences for ecosystem processes. There are also important scalar considerations that arise for the Andean landscapes of interest.

TEMPORAL SCALES IN ANDEAN LANDSCAPES

Landscape dynamism includes temporal shifts in the different spatial elements that make up the mosaic: the patches, the matrix background, and the long, linear features that form corridors. Seasonality can cause minor shifts in those patterns, with leaf fall and flush coordinated with the start and end, respectively, of dry or cold seasons. Changing seasons also bring in their wake different biophysical stresses or cause different kinds or degrees of disturbances. In addition, long-term monitoring often reveals subdecadal oscillations—for example, the El Niño–Southern Oscillation causes such repeated effects through the increased rain or drought that occurs, depending on the location. Indeed, work in Argentina has revealed subdecadal variations in fire that result from El Niño rains but that occur one to two years later, because that is when maximum biomass is available as fuel for fires causing lagged effects (Grau, 2001; see also Kitzberger et al., 2007).

Temporal shifts cause a variety of ecological responses, from physiological adjustments in individual plants to shifts in landscape patchiness over

decades or centuries. Over evolutionary time, as measured in millennia or in relation to the number of generations per unit time (e.g., 1/100 years for a tree species), population sizes and their rates of interpopulation gene flows vary with the size of patches of habitat, which controls the number of individuals in particular patches, and with their interpatch distances, which affect the degree of connectivity and amount of dispersal. As such, there is a temporal scale to landscape phenomena connecting metapopulation dynamics and ecological and evolutionary processes. Thus, edaphic differences in a tropical forest may give rise not only to different vegetation types as mediated through herbivores in ecological time, but over evolutionary time to different plant lineages (e.g., Fine et al., 2004). These considerations shape how different landscapes interact over evolutionary time, potentially allowing Earth system science and evolutionary biology to inform the landscape ecology of the Andes. In addition, the study of landscape genetics is developing promising research approaches (Manel et al., 2003), as is the use of graph (Brooks, 2006; Ferrari et al., 2007) and circuit theory (McRae & Beier, 2007).

Geological history reveals shifts in connectivity and extent of different elevational or life zones in the Andes over very long time spans, with additional dynamism originating with global climate changes and their local and regional consequences (e.g., Montgomery et al., 2001). The Andes include rocks laid down as sediment more than 100 million years ago (Ma). As they rose and folded or faulted, these rocks were transformed over wide areas into their metamorphic derivatives, often alongside additional rock material forming from the cooling of magma and lava forced up from the subsiding Pacific and Caribbean plates. Their rise was episodic, with long periods of stasis followed by relatively rapid periods of heightening (Garzzone et al., 2008). Given this extended and ancient history, no doubt there are many legacies among the Andean flora and fauna resulting from these past geographies, distinctive connectivities, and altered climates that have shaped speciation, promoted endemism, and caused extinctions of some lineages (Young et al., 2002). There are a variety of dry forest plant groups found with fragmented ranges in intermountain valleys and on both sides of the Andes, which have been shown (Pennington et al., 2006) to reflect this colorful geological past. At least some of the genera of Annonaceae found on both sides of the Andes come from dispersal and speciation events estimated by Pirie et al. (2006) to be 10–60 Ma.

However, uplift, volcanism, and other results of tectonics continue to this day in the Andes (Veblen et al., 2007). As a result, some biodiversity patterns are due to much more recent and even ongoing speciation

processes. Andean landscapes often have spatial characteristics that promote the separation and subdivision of species habitat patches. For example, Hughes and Eastwood (2006) show that the Andean members of *Lupinus* L. (Fabaceae) may result from speciation occurring at some of the fastest rates ever documented (2.49 to 3.72 species/1,000,000 years). They suggest that this alacrity was fostered by the repeated development of newly available islandlike habitats at high elevations in the Andes, caused by Quaternary glaciation cycles. In addition, much of the fastest uplift of the Andes has been in the recent geological past, increasing the elevations of the highest cordilleras by more than 2000 m compared with their maximum heights in the Tertiary (Graham et al., 2001). Hughes and Eastwood (2006) suggest that resulting rapid speciation is behind high diversity in a variety of Andean plant genera. Muellner et al. (2005) begin to sort the details explaining current genetic structure of an Andean composite, *Hypochaeris palustris* (Phil.) Wildeman, as caused by differential colonization and survival in refugia. Brumfield and Edwards (2007) suggest similarly complex routes to speciation and occupation of Andean forests by *Thamnophilus* Vieillot antshrikes, while Torres-Carvajal (2007) shows relatively recent divergence and speciation out of the central Andes by *Stenocercus* Duméril & Bibron lizards. Andean landscapes and regions contain legacies of these evolutionary processes. Changes outside the historical range of biophysical variation may cause future extinctions of particular species.

SPATIAL DIMENSIONS OPERATING IN ANDEAN LANDSCAPES

There is also a spatial and scalar aspect to consider as the biodiversity found in a particular landscape will be a subset of that found in the surrounding region, unless they are equal, as can happen in species-poor biomes. The regional context matters; adjacent areas with high connectivity, past or present, share more species with the landscape of interest. Regional connectivity thus influences or controls the composition and evolutionary dynamics of the species to be found in a particular place.

Broad-scale and gradient variables also affect landscapes and species populations (Talley, 2007). For mountains, regional context comes from upland to lowland connections and cross-mountain range influences (Gentry, 1982), in addition to along-cordillera shifts (e.g., Graves, 1988; Rull & Nogué, 2007). Called continua by Seastedt et al. (2004), these spatial transitions provide differential amounts of available habitat and source areas. The continua delimit possible configurations of embedded landscapes; they

influence biodiversity in spatial ways, increasing beta diversity and other place-to-place heterogeneity (e.g., Kattan et al., 2006) and affecting genetic variation (Ohsawa & Ide, 2008). Change in elevation in the Andes produces a series of interrelated shifts in atmospheric gases, solar radiation, wind, temperature ranges, and soil moisture (Körner, 1999), not to mention in species composition (e.g., Terborgh, 1971; La Torre-Cuadros et al., 2007; Sergio & Pedrini, 2007).

The connections of highlands to contiguous lowlands potentially allow those lowlands to serve as sources of colonizing species over long time periods. More important, however, are the long but narrow connections to mountains on the same cordillera, while continued orogenies create potential new habitat for dispersing montane or alpine species. Yet another characteristic of mountains is great site-to-site change in biophysical factors in elevation as well as different bedrocks and aspects. As a result, most any place in high mountains is only a short vertical distance from lowlands, a short horizontal distance from a wetter (or drier) microsite, and centimeters from a slightly different altitude. Distance and dispersal barriers among potential habitat patches become critical features (e.g., Graf et al., 2007).

Barriers that restrict species ranges can split populations and reduce gene flow. Such species may be found in metapopulations characterized by subpopulations linked by occasional dispersal events, affected by local extinctions in particular habitat patches, and with some individuals in marginal or sink habitats. Some of the resulting legacies become conservation priorities (Young et al., 2002). A recent example by Marín et al. (2007) evaluates the phylogeography of vicuña in conservation terms, with evidence of a rapid relatively recent northern range expansion into northern Peru, but with older multiple lineages across the southern distribution limit in Chile and Argentina. Anciently surviving lineages are found among several of the genera endemic to the Andes; some rare Andean species are paleoendemics. These kinds of biologic uniqueness warrant special conservation efforts directed toward taxa without close-living sister groups or centered on the places where they may be endemic. If recent events have caused range reductions or fragmentations, or if there is rapid speciation into archipelago-like habitats, then numerous neoendemics will be present. These species might best be protected by conservation directed at the habitats and places of concern, as presumably the processes behind diversification would also be conserved under those conditions. However, an additional source of spatial heterogeneity comes from Andean land-use systems of intensively farmed plots and gardens, with extensively used rangelands and croplands.

HUMANIZED LANDSCAPES OF THE ANDES

Humans alter land cover and hence landscape mosaics. Thus, part of the key to understanding future changes in the Andes may come from deciphering anthropogenic influences on these kinds of mosaics, mosaic-related phenomena, and mosaic-influencing processes. Ecologic effects in this context would be those affecting species composition and abundance in particular patches and those that alter connectivity among patches. Connectivity for a particular species is affected by the distance, presence, type of dispersal corridor, and type of land cover that composes the matrix (e.g., Kupfer et al., 2006; Nascimento et al., 2006). The type and location of remaining habitat can be a critical feature for surviving native biodiversity (e.g., Devictor & Jiguet, 2007), as is the presence of corridors (Chetkiewicz et al., 2006). Over evolutionary time spans, mosaic landscapes would host variable population sizes and connectivities, which are prime precursors of both extinction and speciation processes for native plants and animals. Humans can cause species extinctions in a matter of years or decades in particular landscapes, while their effects on selection pressures will be a function of the intensities or directions of those pressures and the generation time of the species of concern. There has been inadvertent selection pressure brought to bear on thousands of species due to modifications of habitat through land use and anthropogenic climate change (e.g., Reusch & Wood, 2007; Araújo et al., 2008).

Humanized landscapes are those that are altered in ways that satisfy human needs and goals. Kareiva et al. (2007) postulated that these kinds of modifications made to inhabited landscapes can be considered reminiscent of species domestication by humans, with similar benefits of maximized food production, increased control, and reduced risks of time periods without food, fibers, or fuels. Vulnerability of people to natural hazards in inhabited landscapes of the Andes can be reduced through manipulation of slopes, redirection of rivers, and other farming or engineering approaches (Young & León, 2009). Control of predators through hunting or of pests through pesticides may be augmented by removal of required habitat. Some insect pests of agricultural concern are kept controlled by native predators surviving in edge and matrix habitat (Rand et al., 2006).

While it is commonplace to lament the destructive influences of people on biodiversity, in cultural contexts such as in regard to long-inhabited landscapes of the Andes, there is in fact an increase in some kinds of diversity—for example, as measured in overall habitat diversity or in terms of the genotypes and phenotypes of domesticated plants and animals.

Humans worldwide have brought several hundred species into domestication, shaping their genotypes to create desired phenotypes and products. Several kinds of wheatlike grasses from the eastern Mediterranean were crossed and bred to produce wheat that feeds millions of people today (Salamini et al., 2002). The availability of rice selected for different flooding regimes permits farming on a wide variety of terrains with dry land, wetland, or controlled paddy conditions (Carney, 1991; Khush, 1997). The diversity extant among domesticated guinea pigs that originate from the Andes is useful in laboratories around the world (Spotorno et al., 2006). This kind of agrobiodiversity is considered highly threatened, as much of it is maintained because of agricultural practices supported by cultural norms that may change in the future (Brush, 2000; Young, 2002).

Efforts to promote sustainable land-use practices in the future no doubt would be better informed if they were based on considerations of which practices have proved long-lived and which practices have resulted in undesirable consequences. Agriculture in Europe arose from land-use practices and associated worldviews originating in the Mediterranean—from Greek, Roman, Arab, and other civilizations and influences (Glacken, 1976). Mediterranean shrubland might have been derived from previously forested landscapes that were deforested for timber and agriculture several millennia ago, then maintained in scrub through burning and grazing for livestock (Blondel, 2006; Henkin et al., 2007), with bouts of soil erosion (Butzer, 2005). In the case of the Andes, much change in land cover happened several millennia ago.

Recently, an evaluation of current spatial patterns of vegetation in a site in France concluded that present-day edaphic conditions were not sufficient to explain the patterns found; instead, there were legacies dating back to land use during the Roman conquest that were affecting modern vegetation patterns (Dambrine et al., 2007). A similar finding was made by Pärtel et al. (2007) for explanations of the amount of floristic diversity in calcareous grasslands of Europe in relation to settlements 1000 years BP. It is perhaps ironic that a botanist would need to be conversant with the archaeology of classical antiquity and the Iron Age to understand the causalities at play. Similarly, the origins of current land-use practices in Papua New Guinea can be traced back to 11,000–7000 years BP, when forests and wetlands were converted for croplands (Hope & Tulip, 1994). The Australian outback was settled more than 50,000 years ago with fire becoming a tool of landscape change used by people, although details on the relative importance of the anthropogenic influence on the loss of native species are still controversial (Bowman, 1998).

In the Andes, Dillehay et al. (2007) showed that people were using field agriculture by 9200 years BP. By using dated plant remains from archaeological sites in northern Peru at sites at 500 m elevation, Dillehay et al. also showed cultivation of squash earlier than 9000 years BP, the peanut by at least ca. 7800 years BP, and cotton by ca. 5500 years BP. The Andean landscapes began to be altered in terms of land cover, accompanied by the domestication of wild species and manipulation of land races. There are archaeological remains of fields in that study area with furrows and evidence of irrigation through canals, suggesting social organization of interdependent households by those time periods. Similar kinds of data are available for landscapes in southern Peru (Perry et al., 2006) and generally in the tropical Andes (Denevan, 2001). Paduano et al. (2003) found many weedy plant species in the pollen record of Lake Titicaca sediments beginning ca. 3100 years BP, while Chepstow-Lusty et al. (Chepstow-Lusty & Winfield, 2000; Chepstow-Lusty et al., 2003) report abundant *Ambrosia* L. and Chenopodiaceae pollen from 2200 BCE to 750 BCE in the Cusco area, along with evidence of ancient agroforestry.

Because there are multiple possible combinations of land use and land cover, often their study through time is referred to as research on land-use/land-cover change (LULCC) (Lambin et al., 2001, 2003; Young, 2005). An agent of landscape change can be a person, household, town, or natural agent such as an insect pest or a windstorm. A driver of landscape change may be the economic system or financial event that motivates the people involved, or perhaps a shifting air circulation system that alters the trajectory of a storm that then results in windthrow of tall trees. The landscape mosaic, classifiable into land-use/land-cover units and spatially delineated into patches and corridors, can be tied conceptually to theories and data, in this particular case, on economics and on atmospheric physics. Land change science draws on a wide range of social, biological, and physical sciences for paradigms and explanations (Gutman et al., 2004). Kintz et al. (2006) used this approach to map and quantify change in landscape mosaics of northern Peru over a 13-year period. Most change was related to altered land use as local population size doubled with in-migration. Another component of change was the national park management, and possibly some vegetation shifts were caused directly by climate change. Postigo et al. (2008) recently also used satellite-derived mapping to locate how climate change in south-central Peru was altering land cover that is useful for high-elevation pastoralists. However, some land-use changes were motivated by prices for products from their alpaca and sheep, while still

others are the result of partial out-migration of many members of the households and families.

ANDEAN LANDSCAPE LEGACIES

Legacies of a long history of changes in agriculture and land cover in the Andes can be found in many landscape characteristics (Fig. 1). Soils, for example, can show topographic and micromorphologic features caused by past cultivation and terracing (Sandor & Eash, 1995; Kemp et al., 2006). Similar dated features in a study by Rigsby et al. (2003) reveal human occupation of flat topographic features beginning 10,000 years BP and continuing in the evolving landscapes of southern Peru on different terrain features for the next 10 millennia. Without terracing or following its abandonment, cultivation often results in increased soil erosion (Inbar & Llerena, 2000).

Fire is another source of landscape dynamism. Fire is a natural agent of change in the Andes; however, it is often provoked by lightning strikes, so ignition caused by nature may frequently be limited to the rainy season. As a result, much burning and extensive fires are instead due to human agency, which began several millennia ago. People arrived in South America in the Early Holocene carrying stone weapons, accompanied by dogs, and using fire. Fire as recorded in carbonized wood particles in dated lake sediments can be documented back as far as records reach in Lake Titicaca to 27,500 years BP (Paduano et al., 2003). However, there is an obvious human imprint on the abundance of charcoal in some Andean lakes. For example, Bush et al. (2005) showed a time period ca. 3500 years BP when charcoal dramatically increased. Because they were able to separate out the principle climate-caused shifts caused by a multi-decadal precipitation oscillation by using wavelet analysis, other changes, such as this charcoal increase, would presumably be anthropogenic in causality.

Millennia of Andean agriculture were interrupted by the impact of contact and conquest by Europeans 500 years BP, followed by abrupt declines in human population numbers and then the incorporation of new domesticated species and the development of novel land uses as rural populations slowly recovered (Gade, 1999; Sarmiento, 2003). Colonialism has continued consequences for landscapes (Sluyter, 2001). Because the Spanish were concerned with control of their colonies, they imported and imposed land use as mediated through households clustered into towns and centered on a plaza with a church and administrative buildings. These settlements, known as "reducciones," concentrated houses into small urban areas and were accompanied by altered economic goals for

the people, often involving the provision of taxes, products, or labor to regional or national governments. Both land use and land cover changed.

Today, Andean landscapes not on the wet external flanks of the Andes are dominated by shrubs, not by trees (Fig. 1; Young, 1998). Thus, many Andean landscapes have a shrubland matrix, with remaining forest patches accompanied by other patches containing planted and fallowed fields. Species in those patches will have their local populations shaped by the area, number, and separation of the respective patches. Indeed, in many Andean landscapes, dominant trees are not native species, but are planted eucalypts or pines, which may eliminate some native species due to missing mutualists. Structural features of these humanized landscapes include rock walls, terraces, forest patches, trails, fallow fields, pastures, and house gardens. These land cover types delimit patches of varying value to people for the extraction of firewood and medicinal plants and the production of field crops, fruit trees, and livestock. Fire continues to be used to reduce woody cover and foment sprouting of palatable plants for grazing over extensive areas, even those far from settlements. Andean land use is typically intensive locally around houses and extensive over hillsides and on mountain peaks.

Surviving native species of plants of these landscapes often have small, well-dispersed seeds; can resprout following apical damage; may have thorns or other protection; and are either resilient or inconspicuous (Laegaard, 1992; Young, 1998). Examples given by Young and Keating (2001) for a site in northern Ecuador include *Barnadesia arborea* Kunth, *Brachyotum ledifolium* (Desr.) Triana, *Coriaria ruscifolia* L., *Escallonia myrtilloides* L. f., *Gaultheria foliolosa* Benth., *Maytenus verticillata* (Ruiz & Pav.) DC., *Monnina obtusifolia* Kunth, *Piper barbatum* Kunth, and *Vallea stipularis* L. f. Surviving wildlife species are tolerant of human presence, unattractive as game, and unthreatening to human interests (Young, 1997). Most Andean species of humanized landscapes thrive in open, edge, or successional habitats.

FUTURE GEOGRAPHIES OF THE ANDES: TOWARD A CONCEPTUAL MODEL

Species persistence in the inhabited and utilized landscapes of the Andes will depend on species traits, including their sensitivity to the effects of future change in the biophysical factors that control their distribution and abundance (Scholze et al., 2006; Tewksbury et al., 2008). The effects on species also will be constrained by and mediated through changes in land cover, so LULCC will be critical. Given current global environmental changes and visible

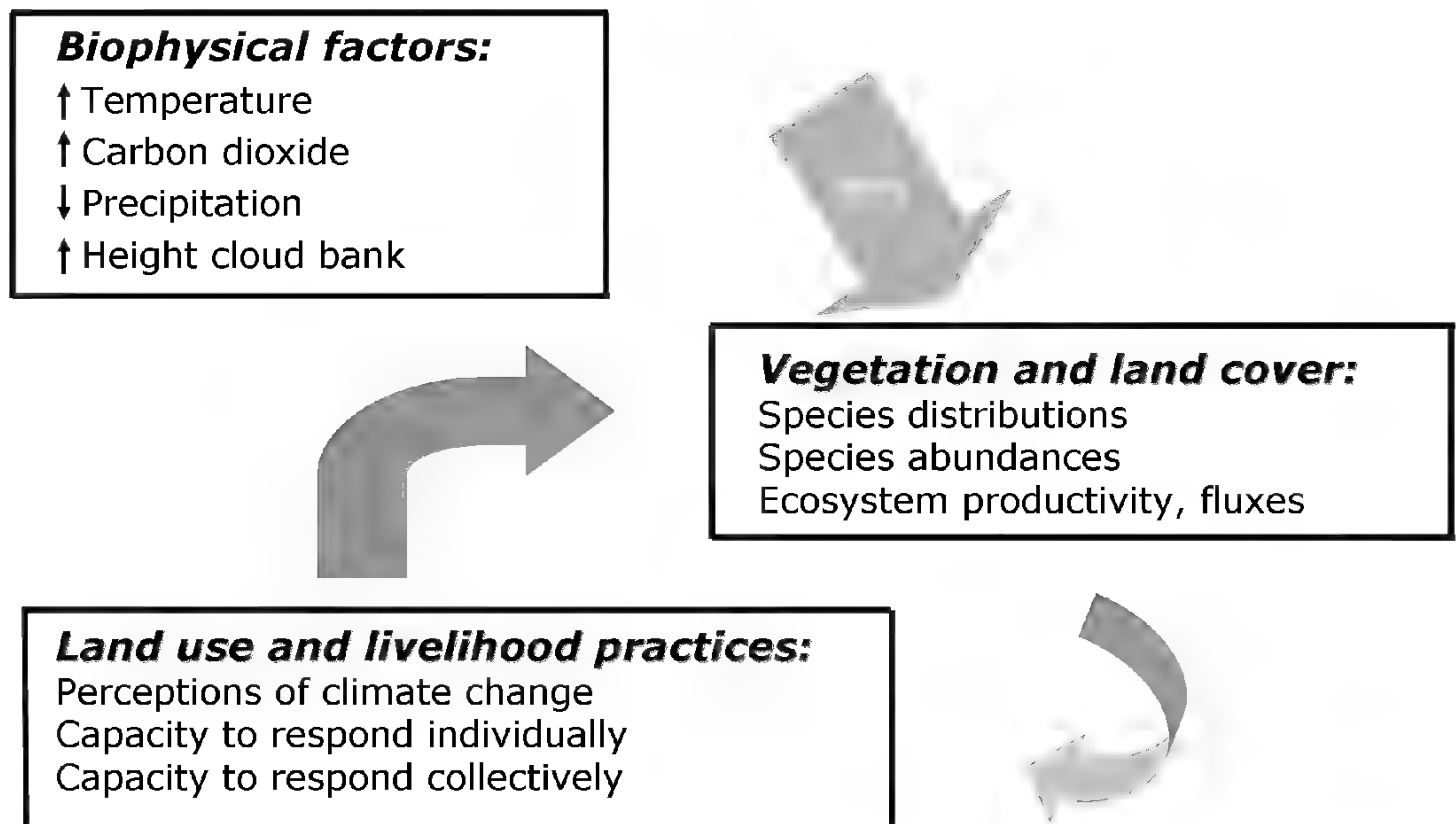

Figure 2. A conceptualization of proposed interactions and feedbacks hypothesized to connect climate change in the Andes, as mediated through biophysical changes to shifting land use and vegetation.

consequences in the high Andes in terms of reduced permanent ice and altered land cover (Ramírez et al., 2001; Vuille et al., 2003; Thompson et al., 2006; Young, 2007), plus increased natural hazards (Carey, 2005; Vilímek et al., 2005), Andean landscape mosaics will continue to shift at least over the next couple of decades. In this section, I develop a conceptual model of how landscapes are being affected and of how species distributions may be changed as a result.

Figure 2 connects the major biophysical factors that are changing in tropical latitudes to land cover and land use. Not only are temperatures increasing, driven by more greenhouse gases such as CO₂, but many tropical areas are expected to have less precipitation (Cook & Vizy, 2008). In addition, there will be upward shifts in altitudes where moisture condenses, fog frequently forms, and cloud forests are found (Foster, 2001). One important way that these environmental controls affect plants is through altered soil properties, such as soil moisture and nutrient availability.

However, the effects on land cover will not be unidirectional given the presence of land use, which can respond quickly through farmers' actions and reactions to cues in the landscape (Young & Lipton, 2006). Thus, Figure 2 includes arrows suggesting links and feedbacks. Shifts in plant growth and composition alter grazing systems and cropping patterns. Land use will change, given the capacity to shift the locations of pastures and field, the knowledge and resources to modify planted crops, and collective

or household capital that permits new livelihood strategies (Mayer, 2002) and external networks (Bebbington, 2000). For the Andes, this means that agriculture and pastoralism must change, with grazing activities moved to higher elevations on newly formed wetlands following glacial retreat and crop choice modified on thousands of agricultural fields; it also implies fewer water resources for the settlements and cities located downslope (Bradley et al., 2006). Predicting shifts of wild species will require information on the bioclimatic envelopes occupied and the additional degree of sensitivity to direct and indirect influences of land use.

The complexity of the more traditional farming systems should provide ample margins for rapid adaptation for the farmers themselves, with households often planting multiple crops and land races on 12 or more different fields, locating them at different elevations and on different exposures (Brush, 1976; Zimmerer, 1996, 1999; Young, 2008). Of course, this resilience assumes that (1) the appropriate knowledge exists and can be transmitted, (2) the needed genetic diversity is available, (3) alternative useful plant or animal stock is on hand as needed, and (4) top-down restrictions on or incentives for certain land uses and production goals by regional or national governments do not constrain household and community adaptation.

Change is constant, and much of the biological and cultural diversity to be found in the inhabited and uninhabited landscapes of the Andes is due to that

Change (warmer, drier)**Cold (wet) adapted species****Priorities****Peaks; Moist enclaves****Warm (dry) adapted species****Matrix**

Figure 3. A conceptual model of spatial implications of future climate change in the tropical Andes for native species. The species' ranges will tend to decrease and fragment, especially for the species adapted either to relatively cold or relatively humid conditions. The converse will take place for the species adapted to relatively warm and/or dry habitats, with their potential distributions both larger and less fragmented. Given these predictions, biodiversity conservation priorities for the species with smaller ranges would need to emphasize the changing high elevations and moist microsites, while the species with larger potential ranges would instead need conservation strategies focused on Andean landscape matrix habitats.

change, whether over centuries, millennia, or millions of years. Given that future change will alter biota, vegetation, and land-use systems relatively quickly (Fig. 2), and hence mosaic-related processes, there might be ways to predict and prepare for consequences. For land use, this would require LULCC measurements that locate and calculate the new biophysical constraints acting on landscapes, while also conducting evaluations capable of elucidating the external influences acting on human decision making, including market signals, land tenure, and alternatives to rural livelihoods. It can be hypothesized that in sites with reduced precipitation or diminished glaciers, less water will require shifts by farmers from rain-fed agricultural systems to more elaborate irrigation schemes, or perhaps to more dependence on livestock such as goats and sheep.

Andean landscape geometries help set contexts and limit possibilities for the populations and metapopulations of native species, thus allowing some degree of predictability (e.g., Seabloom et al., 2002; Starzomski & Srivastava, 2007). Small habitat patches have significant edge effect, while isolated patches have

reduced gene flow and increased rates of local population extinctions. The amount of core forest habitat and the shape of forest patches change as human populations increase and land use intensifies (Kintz et al., 2006), thus likely also reducing population sizes of species requiring large core habitats (e.g., Ewers & Didham, 2006). The rate, type, and location of habitat change in relation to intrinsic population increases of the species of concern are parameters involved in the likelihood of local extinctions (Schrott et al., 2005). The high Andean forest patches studied by Jameson and Ramsay (2007) maintained their sizes over almost 50 years but lost considerable canopy density, thus potentially negatively affecting a subset of the biota sensitive to more open conditions.

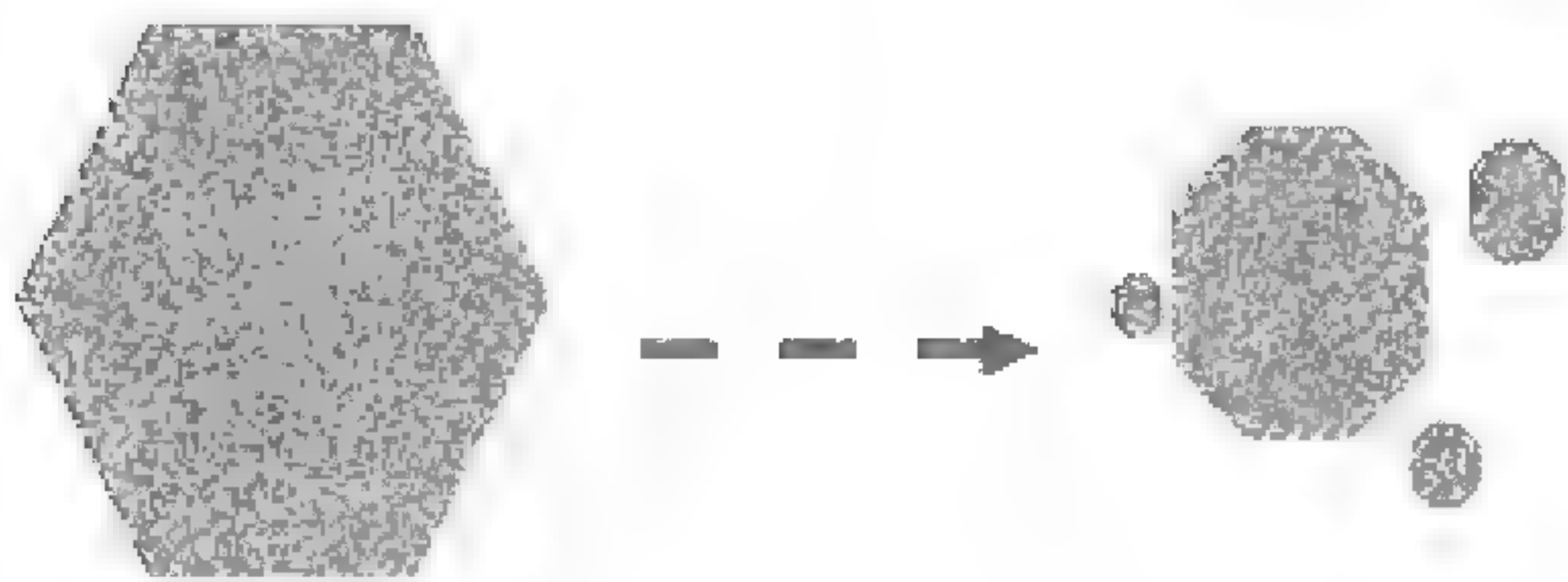
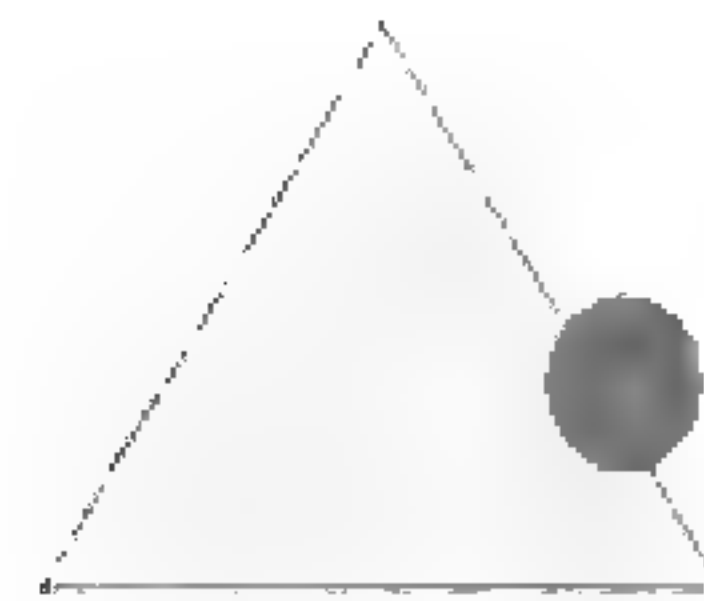
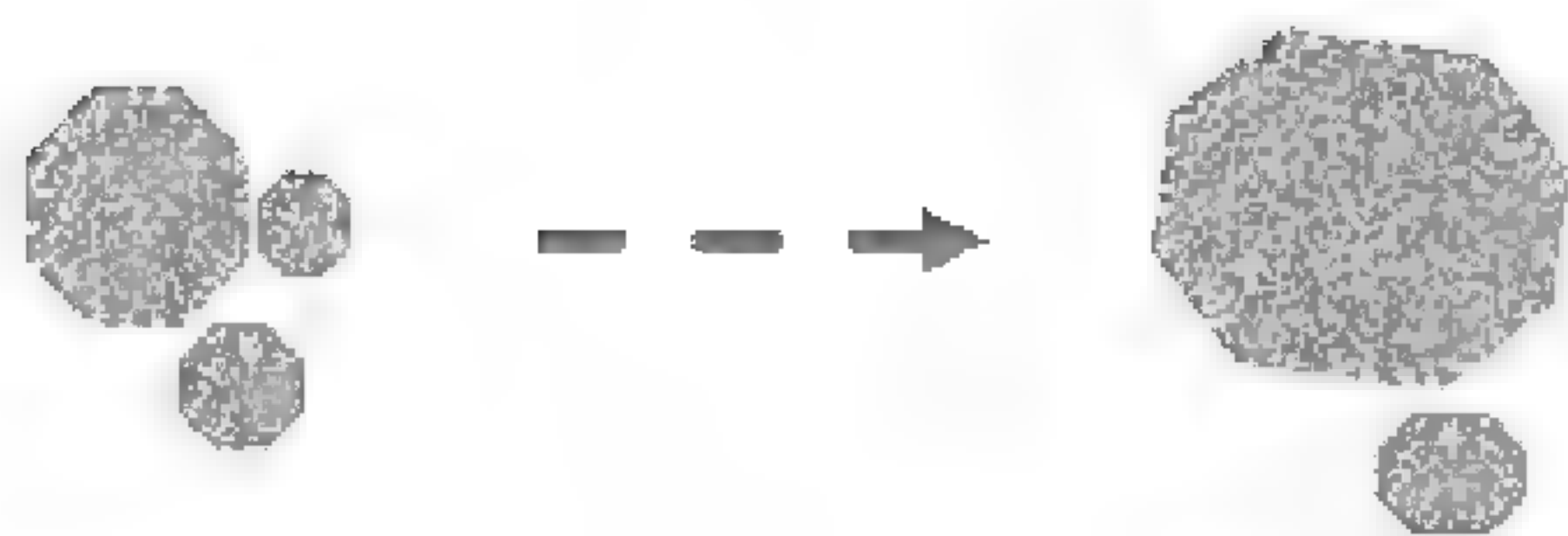
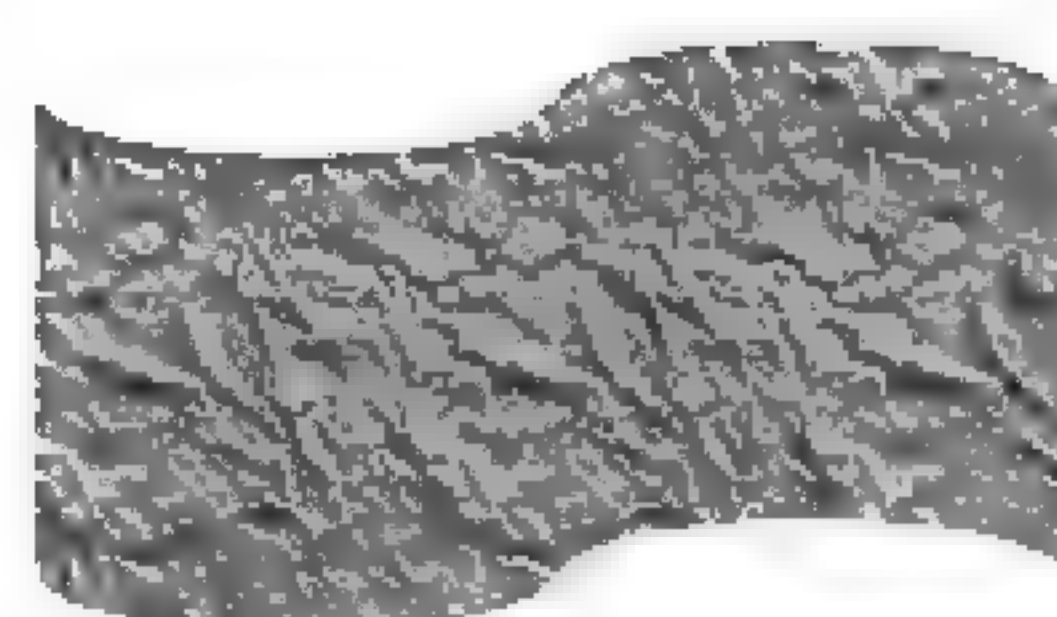
Under warmer and drier conditions, it is likely that native species needing relatively cool or wet conditions will become less common, with reduced ranges (Fig. 3). Note that the ranges not only become smaller overall, but in the rough topography of the Andes, they will often become more fragmented, with species found in smaller areas and many with local popula-

tions in small, isolated habitat patches. Species restricted to high elevations may become extinct in at least part of their ranges (e.g., Thuiller et al., 2005), while those dependent on humid microsites (Killeen et al., 2007) may similarly be affected if those sites no longer exist. Biodiversity conservation priorities for these kinds of species should include the disappearing and unique habitats, as well as places that would permit conservation along long environmental gradients. These are here proposed to be mountain peaks, preferably contiguous to habitat along an elevational gradient, and isolated patches of cloud forest and other very humid habitats, again preferably embedded within larger areas designated for species conservation efforts (Fig. 3).

Intervention strategies for these species would need to be designed to cope with more fragmented habitats (Fig. 3), smaller populations, decreased gene flow, and increased sink habitat incapable of maintaining local populations (Pulliam, 1988; Hanski & Ovaskainen, 2003; Ditto & Frey, 2007; Pompe et al., 2008). The loss of species with mutualistic relationships would increase total amounts of extinctions (Koh et al., 2004; Rezende et al., 2007). As supporting evidence, Golicher et al. (2008) found that the future distributions of the montane forest flora in Chiapas, Mexico, could be evaluated in relation to two groups of species: those adapted to moist and those to cool climatic conditions. Pounds et al. (2006) assembled data suggesting that climate-caused change is the reason behind dramatic extinctions already taking place among Andean amphibians, which are exacerbated by habitat fragmentation.

Large shifts and expansions of ranges of other species are to be expected (Fig. 3). Given species' preexisting adaptations to future biophysical conditions, their distributions would often become not only larger, but less fragmented, and previously isolated populations may be brought into contact. Species that need or are tolerant of warmer conditions would be likely to be found in more sites and/or in sites occurring at higher elevations in the Andes. Species adapted to the dry exposed habitats of much of the inner Andes—the intermountain valleys—might also expand their distributions. Thus, some species will be winners in a sense, with larger potential distributions.

Biodiversity conservation strategies will still be needed, however, even for species predicted to increase their range size (Fig. 3). For example, the rare or desirable species with adaptations that would give them potentially larger ranges are here proposed to need conservation efforts that include the installation of conservation corridors permitting dispersal and the management of landscape matrices such that those species can continue to exist. Intervention strategies

would need to be designed to permit species to occupy new locales through dispersal, and perhaps translocation, and to minimize noxious effects of land use in the dominant part of the landscape—the matrix. Donald and Evans (2006) recently evaluated ways that ecological restoration of matrix would help improve some ecosystem functions in agricultural landscapes; existing approaches to Andean restoration efforts (Sarmiento, 2003) would be reinvigorated with such goals.

CONCLUSIONS

Climate change will likely produce novel habitats (Williams et al., 2007), and in the Andes it will certainly produce large expanses of lands undergoing primary succession on substrates that were previously under glaciers in high mountains (Thompson et al., 2006). Change in the inhabited landscapes of the Andes will be acting on a subset of the original biota, with dangerous and nuisance species removed, and useful or beneficial species encouraged. Some of those species may be rare or absent due to historical events, not because of current biophysical conditions. Other species may be more common than expected because of their resilience to continued human impacts, such as cutting, trampling, or hunting. Still others may be present because of introduction with human migration or trade. In addition, the conceptual model in Figure 3 implies that different spatial outcomes are expected, and thus different strategies are needed for species that are predicted to lose potential distribution because they are temperature sensitive, or for species that are limited in distribution and abundance by moisture. Other species may increase their potential distributions in terms of their bioclimatic constraints (Fig. 3), but may still be of conservation concern because land-use and land-cover changes limit their actual habitat, especially in the humanized landscapes.

Conservation goals that include restoration of populations of original species and natural land cover types will need to consider what time period is to be recreated and whether that goal is desirable and attainable (Hopfensperger et al., 2007). In Europe, the use of heavy-handed management tools, such as deliberate overgrazing or frequent burning and mowing, is used to favor species restricted to open habitats or when the maintenance of early successional vegetation is a conservation objective (e.g., Moro & Gadal, 2007). In the northwestern United States, forest management is being used to alter disturbance regimes in ways meant to maintain native biodiversity (e.g., Odion & Sarr, 2007), while prescribed burning is used in tallgrass prairies of the central United States (Van Dyke et al., 2007). The



Figure 4. High Andean landscape in foreground on the Cordillera Negra of north Peru, with the glaciated Cordillera Blanca dominating the background to the east.

equivalent management options for Andean landscapes need to be designed and calibrated.

Over regional environmental gradients of humidity, elevation, and latitude, these fragmented landscapes are linked or separated by habitat and topographic connectivity (Fischer & Lindenmeyer, 2006). Figure 4 is a landscape photograph taken in the region of Ancash in northern Peru. It shows in the foreground a stand of 5-m circumference *Puya raimondii* Harms growing on the Cordillera Negra, a mountain range with no permanent ice and with land-use systems dependent on seasonal rains. Similarly, mountain ranges elsewhere that are losing their glaciers are also becoming less productive for farmers who must deal with limited water (Young & Lipton, 2006).

In the background of Figure 4, the Cordillera Blanca rises 2000 m higher, is capped by ice caps, and is often shrouded in clouds. People living on slopes below this range have access to water from glacial lakes and from ice melt; most use irrigation to extend growing seasons, increase agricultural productivity, and produce crops for distant markets. Changing land use will act in complex ways on the shifting habitats that contain wild native species on these two mountain cordilleras. For

example, the native plants of the Cordillera Negra will be affected by both warmer temperatures and drier conditions, and livestock grazing will likely become even more extensive along that mountain range. In turn, native species of the Cordillera Blanca will have their respective potential distributions changed by climate shifts, but they will also be relocated inside the higher elevations that are within the boundaries of Huascarán National Park. The presence of a conservation-protected area makes additional conservation strategies possible, although there are likely to be increases in pressure on the park from land use extending into the park from adjacent rural communities.

Andean pastoralists often will quickly shift livestock to higher elevations as ice retreats (Young & Lipton, 2006; Postigo et al., 2008). Every planting season, Andean farmers change or at least reevaluate what crops and what fields are to be used. Thus, certain kinds of adaptation by individual households or on lands managed communally will be quick, taking place in less than one year, unless other socioeconomic, legal, or political factors impede them (Fig. 2). Small-scale farmers studied in China by Hageback et al. (2005) showed considerable potential

adaptation to climate change, including the diversification of livelihoods. Bates (2002) found that another common response is out-migration by people from areas under environmental stress. Relevant studies in the Andes are yet to be done. Morton (2007) worried that complex subsistence agriculture in general is not sufficiently studied in relation to climate change, and future influences on pasture species and on crops other than the major commercial species have not been research foci (Tubiello et al., 2007; Lobell et al., 2008). Policies need to promote adaptation (Howden et al., 2007), although top-down efforts may not be successful in developing countries.

Additional aspects of Andean agrobiodiversity may also require monitoring and intervention. The genotypes of traditionally used plants are threatened because of market forces, government subsidies for only a subset of the varieties, and loss of traditional knowledge (Brush, 2000). Climate change may further reduce the use of land races no longer as productive and yet containing gene complexes possibly useful under other conditions. Predicting which species or varieties will prosper under future biophysical conditions would allow institutions to foster their use and maintenance among farmers.

Humanized Andean landscapes are used in ways that favor some wild species and not others. The continued persistence of native species in these landscapes may depend as much on the patterns and dynamics of landscape mosaics as on species characteristics themselves (Danielson, 1991; Ovasainen et al., 2002). Knowledge of current mosaic patterns, land-use change, and historical legacies will permit better understanding of landscape processes and possible conservation goals (Lunt & Spooner, 2005). For example, the carbon found in Andean fields will have value for carbon sequestration payments (Antle et al., 2007), giving additional conservation reasons for working with agricultural landscapes. Global environmental change will shift some of the environmental continua affecting agriculture and biota, especially temperature and humidity regimes along elevational gradients. Both land-use systems and conservation efforts will need to respond spatially to these shifts in the future, at landscape and regional scales, and they should also be cognizant of the long temporal scales that gave rise to valued diversity and the changes that can cause its loss over relatively short periods.

Literature Cited

- Antle, J. M., J. J. Stoorvogel & R. O. Valdivia. 2007. Assessing the economic impacts of agricultural carbon sequestration: Terraces and agroforestry in the Peruvian Andes. *Agric. Eco-syst. Environm.* 122: 435–445.
- Araújo, M. B., D. Nogués-Bravo, I. Reginster, M. Rounsevell & R. J. Whittaker. 2008. Exposure of European biodiversity to changes in human-induced pressures. *Environm. Sci. Policy* 11: 38–45.
- Bates, D. C. 2002. Environmental refugees? Classifying human migrations caused by environmental change. *Populat. Environm.* 23: 465–477.
- Bebbington, A. 2000. Reencountering development: Livelihood transitions and place transformations in the Andes. *Annals Assoc. Amer. Geogr.* 90: 495–520.
- Blondel, J. 2006. The “design” of Mediterranean landscapes: A millennial study of humans and ecological systems during the historic period. *Human Ecol.* 34: 713–729.
- Bodin, O., M. Tengö, A. Norman, J. Lundberg & T. Elmqvist. 2006. The value of small size: Loss of forest patches and ecological thresholds in southern Madagascar. *Ecol. Applic.* 16: 440–451.
- Bowman, D. M. J. S. 1998. The impact of aboriginal landscape burning on the Australian biota. *New Phytol.* 140: 385–410.
- Bradley, R. S., M. Vuille, H. F. Diaz & W. Vergara. 2006. Climate change: Threats to water supplies in the tropical Andes. *Science* 312: 1755–1756.
- Brooks, C. P. 2006. Quantifying population substructure: Extending the graph-theoretic approach. *Ecology* 87: 864–872.
- Brumfield, R. T. & S. V. Edwards. 2007. Evolution into and out of the Andes: A Bayesian analysis of historical diversification in *Thamnophilus* antshrikes. *Evolution* 61: 346–367.
- Brush, S. B. 1976. Man’s use of an Andean ecosystem. *Human Ecol.* 4: 147–166.
- (editor). 2000. *Genes in the Field: On-Farm Conservation of Crop Diversity*. Lewis Publishers, Boca Raton.
- Bush, M. B., B. C. S. Hansen, D. T. Rodbell, G. O. Seltzer, K. R. Young, B. León, M. B. Abbott, M. R. Silman & W. D. Gosling. 2005. A 17,000-year history of Andean climate and vegetation change from Laguna de Chochos, Peru. *J. Quatern. Sci.* 20: 703–714.
- Butzer, K. W. 2005. Environmental history in the Mediterranean world: Cross-disciplinary investigation of cause-and-effect for degradation and soil erosion. *J. Archaeol. Sci.* 32: 1773–1800.
- Carey, M. 2005. Living and dying with glaciers: People’s historical vulnerability to avalanches and outburst floods in Peru. *Global Planet. Change* 47: 122–134.
- Carney, J. 1991. Indigenous soil and water management in Senegambian rice farming systems. *Agric. Human Values* 8: 37–48.
- Chepstow-Lusty, A. & M. Winfield. 2000. Inca agroforestry: Lessons from the past. *Ambio* 29: 322–328.
- , M. R. Frogley, B. S. Bauer, M. B. Bush & A. Tupayachi Herrera. 2003. A late Holocene record of arid events from the Cuzco region, Peru. *J. Quatern. Sci.* 18: 491–502.
- Chetkiewicz, C.-L. B., C. C. St. Clair & M. S. Boyce. 2006. Corridors for conservation: Integrating pattern and process. *Annual Rev. Ecol. Syst.* 37: 317–342.
- Clark, D. B., D. A. Clark & J. M. Read. 1998. Edaphic variation and the mesoscale distribution of tree species in a Neotropical rain forest. *J. Ecol.* 86: 101–112.
- Coley, P. D. & J. A. Barone. 1996. Herbivory and plant defenses in tropical forests. *Annual Rev. Ecol. Syst.* 27: 305–335.
- Cook, K. H. & E. K. Vizy. 2008. Effects of twenty-first-century climate change on the Amazon rain forest. *J. Climate* 21: 542–560.

- Dambrine, E., J.-L. Dupouey, L. Laiüt, L. Humbert, M. Thinon, T. Beaufils & H. Richard. 2007. Present forest biodiversity patterns in France related to former Roman agriculture. *Ecology* 88: 1430–1439.
- Danielson, B. J. 1991. Communities in a landscape: The influence of habitat heterogeneity on the interactions between species. *Amer. Naturalist* 138: 1105–1120.
- Denevan, W. M. 2001. *Cultivated Landscapes of Native Amazonia and the Andes*. Oxford University Press, New York.
- Devictor, V. & F. Jiguet. 2007. Community richness and stability in agricultural landscapes: The importance of surrounding habitats. *Agric. Eco-syst. Environm.* 120: 179–184.
- Dillehay, T. D., J. Rossen, T. C. Andres & D. E. Williams. 2007. Pre-ceramic adoption of peanut, squash, and cotton in northern Peru. *Science* 316: 1890–1893.
- Ditto, A. M. & J. K. Frey. 2007. Effects of ecogeographic variables on genetic variation in montane mammals: Implications for conservation in a global warming scenario. *J. Biogeogr.* 34: 1136–1149.
- Donald, P. F. & A. D. Evans. 2006. Habitat connectivity and matrix restoration: The wider implications of agri-environment schemes. *J. Appl. Ecol.* 43: 209–218.
- Dorrough, J. W., J. E. Ash, S. Bruce & S. McIntyre. 2007. From plant neighbourhood to landscape scales: How grazing modifies native and exotic plant species richness in grassland. *Plant Ecol.* 191: 185–198.
- Dwire, K. A., J. B. Kauffman, E. N. J. Brookshire & J. E. Baham. 2004. Plant biomass and species composition along an environmental gradient in montane riparian meadows. *Oecologia* 139: 309–317.
- Ellenberg, H. 1979. Man's influence on tropical mountain ecosystems in South America. *J. Ecol.* 67: 401–416.
- Ewers, R. M. & R. K. Didham. 2007. The effect of fragment shape and species' sensitivity to habitat edges on animal population size. *Conservation Biol.* 21: 926–936.
- Ferrari, J. R., T. R. Lookingbill & M. C. Neel. 2007. Two measures of landscape-graph connectivity: Assessment across gradients in area and configuration. *Landscape Ecol.* 22: 1315–1323.
- Fine, P. V. A., I. Mesones & P. D. Coley. 2004. Herbivores promote habitat specialization by trees in Amazonian forests. *Science* 30: 663–665.
- Fischer, J. & D. B. Lindenmayer. 2006. Beyond fragmentation: The continuum model for fauna research and conservation in human-modified landscapes. *Oikos* 112: 473–480.
- Forester, J. D., A. R. Ives, M. G. Turner, D. P. Anderson, D. Fortin, H. L. Beyer, D. W. Smith & M. S. Boyce. 2007. State-space models link elk movement patterns to landscape characteristics in Yellowstone National Park. *Ecol. Monogr.* 77: 285–299.
- Forman, R. T. T. 1995. *Land Mosaics: The Ecology of Landscapes and Regions*. Cambridge University Press, Cambridge.
- Foster, D., F. Swanson, J. Aber, I. Burke, N. Brokaw, D. Tilman & A. Knapp. 2003. The importance of land-use legacies to ecology and conservation. *BioScience* 53: 77–89.
- Foster, P. 2001. The potential negative impacts of global climate change on tropical montane cloud forests. *Earth-Sci. Rev.* 55: 73–106.
- Franklin, J. F. 1993. Preserving biodiversity: Species, ecosystems, or landscapes? *Ecol. Applic.* 3: 202–205.
- Gade, D. W. 1999. *Nature and Culture in the Andes*. University of Wisconsin Press, Madison.
- Garzzone, C. N., G. D. Hoke, J. C. Libarkin, S. Withers, B. MacFadden, J. Eiler, P. Ghosh & A. Mulch. 2008. Rise of the Andes. *Science* 320: 1304–1307.
- Gentry, A. H. 1982. Neotropical floristics: Phytogeographical connections between Central and South America, Pleistocene climate fluctuations, or an accident of the Andean orogeny? *Ann. Missouri Bot. Gard.* 69: 557–593.
- Glacken, C. J. 1976. *Traces on the Rhodian Shore*. University of California Press, Berkeley.
- Golicher, D. J., L. Cayuela, J. B. M. Alkemade, M. González-Espinosa & N. Ramírez-Marcial. 2008. Applying climatically associated species pools to the modelling of compositional change in tropical montane forests. *Global Ecol. Biogeogr.* 17: 262–273.
- Graf, R. F., S. Kramer-Schadt, N. Fernández & V. Grimm. 2007. What you see is where you go? Modeling dispersal in mountainous landscapes. *Landscape Ecol.* 22: 853–866.
- Graham, A., K. M. Gregory-Wodzicki & K. L. Wright. 2001. *Studies in Neotropical paleobotany*. XV. A Mio-Pliocene palynoflora from the Eastern Cordillera, Bolivia: Implications for the uplift history of the central Andes. *Amer. J. Bot.* 88: 1545–1557.
- Grau, H. R. 2001. Regional-scale spatial patterns of fire in relation to rainfall gradients in sub-tropical mountains, NW Argentina. *Global Ecol. Biogeogr.* 10: 133–146.
- Graves, G. R. 1988. Linearity of geographic range and its possible effect on the population structure of Andean birds. *Auk* 105: 47–52.
- Gutman, G., A. Janetos, C. Justice, E. Moran, J. Mustard, R. Rindfuss, D. Skole & B. L. Turner II (editors). 2004. *Land Change Science: Observing, Monitoring, and Understanding Trajectories of Change on the Earth's Surface*. Kluwer, New York.
- Hageback, J., J. Sundberg, M. Ostwald, D. Chen, X. Yun & P. Knutsson. 2005. Climate variability and land-use change in Danangou watershed, China—Examples of small-scale farmers' adaptation. *Climatic Change* 72: 189–212.
- Hanski, I. & O. Ovaskainen. 2003. Metapopulation theory for fragmented landscapes. *Theor. Populat. Biol.* 64: 119–127.
- Henkin, Z., L. Hadar & I. Noy-Meir. 2007. Human-scale structural heterogeneity induced by grazing in a Mediterranean woodland landscape. *Landscape Ecol.* 22: 577–587.
- Hope, G. & J. Tulip. 1994. A long vegetation history from lowland Irian-Jaya, Indonesia. *Paleogeogr. Palaeoclimatol. Palaeoecol.* 109: 385–398.
- Hopfensperger, K. N., K. A. M. Engelhardt & S. W. Seagle. 2007. Ecological feasibility studies in restoration decision making. *Environm. Managem.* 39: 843–852.
- Howden, S. M., J.-F. Soussana, F. N. Tubiello, N. Chhetri, M. Dunlop & H. Meinke. 2007. Adapting agriculture to climate change. *Proc. Natl. Acad. Sci. U.S.A.* 104: 19691–19696.
- Hughes, C. & R. Eastwood. 2006. Island radiation on a continental scale: Exceptional rates of plant diversification after uplift of the Andes. *Proc. Natl. Acad. Sci. U.S.A.* 103: 10334–10339.
- Ibarra-Manríquez, G. & M. Martínez-Ramos. 2002. Landscape variation of liana communities in a Neotropical rain forest. *Pl. Ecol.* 160: 91–112.
- Inbar, M. & C. A. Llerena. 2000. Erosion processes in high mountain agricultural terraces in Peru. *Mountain Res. Developm.* 20: 72–79.
- Jameson, J. S. & P. M. Ramsay. 2007. Changes in high-altitude *Polylepis* forest cover and quality in the Cordillera de Vilcanota, Peru, 1956–2005. *Biol. Conservation* 138: 38–46.
- Kareiva, P., S. Watts, R. McDonald & T. Boucher. 2007. Domesticated nature: Shaping landscapes and ecosystems for human welfare. *Science* 316: 1866–1869.

- Kattan, G. H., P. Franco, C. A. Saavedra-Rodríguez, C. Valderrama, V. Rojas, D. Osorio & J. Martínez. 2006. Spatial components of bird diversity in the Andes of Colombia: Implications for designing a regional reserve system. *Conservation Biol.* 20: 1203–1211.
- Kemp, R., N. Branch, B. Silva, F. Meddens, A. Williams, A. Kendall & C. Vivanco. 2006. Pedosedimentary, cultural and environmental significance of paleosols within pre-hispanic agricultural terraces in the southern Peruvian Andes. *Quatern. Int.* 158: 13–22.
- Khush, G. S. 1997. Origin, dispersal, cultivation and variation of rice. *Pl. Molec. Biol.* 35: 25–34.
- Killeen, T. J., M. Douglas, T. Consiglio, P. M. Jørgensen & J. Mejia. 2007. Dry spots and wet spots in the Andean hotspot. *J. Biogeogr.* 34: 1357–1373.
- Kintz, D. B., K. R. Young & K. A. Crews-Meyer. 2006. Implications of land use/land cover change in the buffer zone of a national park in the tropical Andes. *Environm. Managem.* 38: 238–252.
- Kitzberger, T., P. M. Brown, E. K. Heyerdahl, T. W. Swetnam & T. T. Veblen. 2007. Contingent Pacific-Atlantic ocean influence on multicentury wildfire synchrony over western North America. *Proc. Natl. Acad. Sci. U.S.A.* 104: 543–548.
- Koh, L. P., R. R. Dunn, N. S. Sodhi, R. K. Colwell, H. C. Proctor & V. S. Smith. 2004. Species coextinctions and the biodiversity crisis. *Science* 305: 1632–1634.
- Körner, C. 1999. *Alpine Plant Life: Functional Plant Ecology of High Mountain Ecosystems*. Springer, Berlin.
- Kupfer, J. A., G. P. Malanson & S. B. Franklin. 2006. Not seeing the ocean for the islands: The mediating influence of matrix-based processes on forest fragmentation effects. *Global Ecol. Biogeogr.* 15: 8–20.
- Laegaard, S. 1992. Influence of fire in the grass páramo vegetation of Ecuador. Pp. 151–170 *in* H. Balslev & J. L. Luteyn (editors), *Páramo: An Andean Ecosystem under Human Influence*. Academic Press, London.
- Lambin, E. F., H. J. Geist & E. Lepers. 2003. Dynamics of land-use and land-cover change in tropical regions. *Ann. Rev. Environm. Res.* 28: 205–241.
- , B. L. Turner, H. J. Geist, S. B. Agbola, A. Angelsen, J. W. Bruce, O. T. Coomes, R. Dirzo, G. Fischer, C. Folke, P. S. George, K. Homewood, J. Imbernon, R. Leemans, X. Lin, E. F. Moran, M. Mortimore, P. S. Ramakrishnan, J. F. Richards, H. Skånes, W. Steffen, G. D. Stone, U. Svedin, T. A. Veldkamp, C. Vogel & J. Xuy. 2001. The causes of land-use and land-cover change: Moving beyond the myths. *Global Environm. Change* 11: 261–269.
- La Torre-Cuadros, M. A., S. Herrando-Pérez & K. R. Young. 2007. Diversity and structural patterns for tropical montane and premontane forests of central Peru, with an assessment of the use of higher-taxon surrogacy. *Biodivers. & Conservation* 16: 2965–2988.
- Lobell, D. B., M. B. Burke, C. Tebaldi, M. D. Mastrandrea, W. P. Falcon & R. L. Naylor. 2008. Prioritizing climate change adaptation needs for food security in 2030. *Science* 319: 607–610.
- Lunt, I. D. & P. G. Spooner. 2005. Using historical ecology to understand patterns of biodiversity in fragmented agricultural landscapes. *J. Biogeogr.* 32: 1859–1873.
- Manel, S., M. K. Schwartz, G. Luikart & P. Taberlet. 2003. Landscape genetics: Combining landscape ecology and population genetics. *Trends Ecol. Evol.* 18: 189–197.
- Marín, J. C., C. S. Casey, M. Kadwell, K. Yaya, D. Hoces, J. Olazabal, R. Rosadio, J. Rodriguez, A. Spotorno, M. W. Bruford & J. C. Wheeler. 2007. Mitochondrial phylogeography and demographic history of the Vicuña: Implications for conservation. *Heredity* 99: 70–80.
- Mayer, E. 2002. *The Articulated Peasant: Household Economies in the Andes*. Westview Press, Boulder.
- McRae, B. H. & P. Beier. 2007. Circuit theory predicts gene flow in plant and animal populations. *Proc. Natl. Acad. Sci. U.S.A.* 104: 19885–19890.
- Montgomery, D. R., G. Balco & S. D. Willett. 2001. Climate, tectonics, and the morphology of the Andes. *Geology* 29: 579–582.
- Moro, D. & S. Gadal. 2007. Benefits of habitat restoration to small mammal diversity and abundance in a pastoral agricultural landscape in mid-Wales. *Biodivers. & Conservation* 16: 3543–3557.
- Morton, J. F. 2007. The impact of climate change on smallholder and subsistence agriculture. *Proc. Natl. Acad. Sci. U.S.A.* 104: 19680–19685.
- Muchhala, N. & P. Jarrín-V. 2002. Flower visitation by bats in cloud forests of western Ecuador. *Biotropica* 34: 387–395.
- Muellner, A. N., K. Tremetsberger, T. Stuessy & C. M. Baeza. 2005. Pleistocene refugia and recolonization routes in the southern Andes: Insights from *Hypochaeris palustris* (Asteraceae, Lactuceae). *Molec. Ecol.* 14: 203–212.
- Nascimento, H. E. M., A. C. S. Andrade, J. L. C. Camargo, W. F. Laurance, S. G. Laurance & J. E. L. Ribeiro. 2006. Effects of the surrounding matrix on tree recruitment in Amazonian forest fragments. *Conservation Biol.* 20: 853–860.
- Noss, R. F. 1990. Indicators for monitoring biodiversity: A hierarchical approach. *Conservation Biol.* 4: 355–364.
- Odion, D. C. & D. A. Sarr. 2007. Managing disturbance regimes to maintain biological diversity in forested ecosystems of the Pacific Northwest. *Forest Ecol. Managem.* 246: 57–65.
- Ohsawa, T. & Y. Ide. 2008. Global patterns of genetic variation in plant species along vertical and horizontal gradients on mountains. *Global Ecol. Biogeogr.* 17: 152–163.
- Ovaskainen, O., K. Sato, J. Bascompte & I. Hanski. 2002. Metapopulation models for extinction threshold in spatially correlated landscapes. *J. Theor. Biol.* 215: 95–108.
- Paduano, G. M., M. B. Bush, P. A. Baker, S. C. Fritz & G. O. Seltzer. 2003. A vegetation and fire history of Lake Titicaca since the Last Glacial Maximum. *Palaeogeogr. Palaeoclimatol. Palaeoecol.* 194: 259–279.
- Palacios, E. & A. Rodríguez. 2001. Ranking pattern and use of space in a group of red howler monkeys (*Alouatta seniculus*) in a southeastern Colombian rainforest. *Amer. J. Primatol.* 55: 233–251.
- Pärtel, M., A. Helm, T. Reitalu, J. Liira & M. Zobel. 2007. Grassland diversity related to the Late Iron Age human population density. *J. Ecol.* 95: 574–582.
- Pennington, R. T., G. P. Lewis & J. A. Ratter (editors). 2006. *Neotropical Savannas and Seasonally Dry Forests: Plant Diversity, Biogeography, and Conservation*. The Systematics Association Special Volume Series 69. CRC, Boca Raton.
- Perry, L., D. H. Sandweiss, D. R. Piperno, K. Rademaker, M. A. Malpass, A. Umire & P. de la Vera. 2006. Early maize agriculture and interzonal interaction in southern Peru. *Nature* 440: 76–79.
- Pirie, M. D., L. W. Chatrou, J. B. Mols, R. H. J. Erkens & J. Oosterhof. 2006. “Andean-centered” genera in the short-branch clade of Annonaceae: Testing biogeographical hypotheses using phylogeny reconstruction and molecular dating. *J. Biogeogr.* 33: 31–46.
- Pitman, N. C. A., P. M. Jørgensen, R. S. R. Williams, S. León-Yáñez & R. Valencia. 2002. Extinction rate estimates for a modern Neotropical flora. *Conservation Biol.* 16: 1427–1431.

- Plantegenest, M., C. Le May & F. Fabre. 2007. Landscape epidemiology of plant diseases. *J. Royal Soc. Interface* 4: 963–972.
- Pompe, S., J. Hanspach, F. Badeck, S. Klotz, W. Thuiller & I. Kühn. 2008. Climate and land use change impacts on plant distributions in Germany. *Biol. Lett.* 4: 564–567.
- Postigo, J., K. R. Young & K. A. Crews. 2008. Change and continuity in a pastoralist community in the high Peruvian Andes. *Human Ecol.* 36: 535–551.
- Pounds, J. A., M. R. Bustamante, L. A. Coloma, J. A. Consuegra, M. P. L. Fogden, F. N. Foster, E. La Marca, K. L. Masters, A. Merino-Viteri, R. Puschendorf, S. R. Ron, G. A. Sánchez-Azofeifa, C. J. Still & B. E. Young. 2006. Widespread amphibian extinctions from epidemic disease driven by global warming. *Nature* 439: 161–167.
- Pulliam, H. R. 1988. Sources, sinks, and population regulation. *Amer. Naturalist* 132: 652–661.
- Ramírez, E., B. Francou, P. Ribstein, M. Descloitres, R. Guérin, J. Mendoza, R. Gallaire, B. Pouyaud & E. Jordan. 2001. Small glaciers disappearing in the tropical Andes: A case study in Bolivia: Glaciar Chacaltaya (16°S). *J. Glaciol.* 47: 187–194.
- Rand, T. A., J. M. Tylianakis & T. Tschamntke. 2006. Spillover edge effects: The dispersal of agriculturally subsidized insect natural enemies into adjacent natural habitats. *Ecol. Lett.* 9: 603–614.
- Redford, K. H. 1992. The empty forest. *BioScience* 42: 412–422.
- Reusch, T. B. H. & T. E. Wood. 2007. Molecular ecology of global change. *Molec. Ecol.* 16: 3973–3992.
- Rezende, E. L., J. E. Lavabre, P. R. Guimarães Jr., P. Jordano & J. Bascompte. 2007. Non-random coextinctions in phylogenetically structured mutualistic networks. *Nature* 448: 925–928.
- Rigsby, C. A., P. A. Baker & M. S. Aldenderfer. 2003. Fluvial history of the Rio Ilave valley, Peru, and its relationship to climate and human history. *Palaeogeogr. Palaeoclimatol. Palaeoecol.* 194: 165–185.
- Ripple, W. J., E. J. Larsen, R. A. Renkin & D. W. Smith. 2001. Trophic cascades among wolves, elk and aspen on Yellowstone National Park's northern range. *Biol. Conservation* 102: 227–234.
- Rodríguez-Cabal, M. A., M. A. Miasen & A. J. Novaro. 2007. Habitat fragmentation disrupts a plant-disperser mutualism in the temperate forest of South America. *Biol. Conservation* 139: 195–202.
- Rull, V. & S. Nogué. 2007. Potential migration routes and barriers for vascular plants of the Neotropical Guyana highlands during the Quaternary. *J. Biogeogr.* 34: 1327–1341.
- Salamini, F., H. Özkan, A. Brandolini, R. Schäfer-Pregl & W. Martin. 2002. Genetics and geography of wild cereal domestication in the Near East. *Nat. Rev. Genet.* 3: 429–441.
- Sandor, J. A. & N. S. Eash. 1995. Ancient agricultural soils in the Andes of southern Peru. *J. Soil Sci. Soc. Amer.* 59: 170–179.
- Sarmiento, F. O. 2003. Anthropogenic change in the landscapes of highland Ecuador. *Geogr. Rev.* 92: 213–234.
- Schmitz, O. J. 2008. Effects of predator hunting mode on grassland ecosystem function. *Science* 319: 952–954.
- Scholze, M., W. Knorr, N. W. Arnell & I. C. Prentice. 2006. A climate-change risk analysis for world ecosystems. *Proc. Natl. Acad. Sci. U.S.A.* 103: 13116–13120.
- Schrott, G. R., K. A. With & A. W. King. 2005. On the importance of landscape history for assessing extinction risk. *Ecol. Applic.* 15: 493–506.
- Seabloom, E. W., A. P. Dobson & D. M. Stoms. 2002. Extinction rates under nonrandom patterns of habitat loss. *Proc. Natl. Acad. Sci. U.S.A.* 99: 11229–11234.
- Seastedt, T. R., W. D. Bowman, T. N. Caine, D. McKnight, A. Townsend & M. W. Williams. 2004. The landscape continuum: A model for high-elevation ecosystems. *BioScience* 54: 111–121.
- Sergio, F. & P. Pedrini. 2007. Biodiversity gradients in the Alps: The overriding importance of elevation. *Biodivers. & Conservation* 16: 3243–3254.
- Sluyter, A. 2001. Colonialism and landscape in the Americas: Material/conceptual transformations and continuing consequences. *Ann. Assoc. Amer. Geogr.* 91: 410–428.
- Smith, D. W., R. O. Peterson & D. B. Houston. 2003. Yellowstone after wolves. *BioScience* 53: 330–340.
- Spotorno, A. E., J. C. Marín, G. Manríquez, J. P. Valladares, E. Rico & C. Rivas. 2006. Ancient and modern steps during the domestication of guinea pigs (*Cavia porcellus* L.). *J. Zool.* 270: 57–62.
- Starzomski, B. M. & D. S. Srivastava. 2007. Landscape geometry determines community response to disturbance. *Oikos* 116: 690–699.
- Stueve, K. M., C. W. Lafon & R. E. Isaacs. 2007. Spatial patterns of ice storm disturbance on a forested landscape in the Appalachian Mountains, Virginia. *Area* 39: 20–30.
- Svenning, J.-C. 2001. Environmental heterogeneity, recruitment limitation and the mesoscale distribution of palms in a tropical montane rain forest. *J. Trop. Ecol.* 17: 97–113.
- Talley, T. S. 2007. Which spatial heterogeneity framework? Consequences for conclusions about patchy population distributions. *Ecology* 88: 1476–1489.
- Terborgh, J. 1971. Distribution on environmental gradients: Theory and a preliminary interpretation of distributional patterns in the avifauna of the Cordillera Vilcabamba, Peru. *Ecology* 52: 23–40.
- Tewksbury, J. J., R. B. Huey & C. A. Deutsch. 2008. Putting the heat on tropical animals. *Science* 320: 1296–1297.
- Thompson, L. G., E. Mosley-Thompson, H. Brecher, M. Davis, B. León, D. Les, P.-N. Lin, T. Mashiotta & K. Mountain. 2006. Abrupt tropical climate change: Past and present. *Proc. Natl. Acad. Sci. U.S.A.* 103: 10536–10543.
- Thuiller, W., S. Lavorel, M. B. Araújo, M. T. Sykes & I. C. Prentice. 2005. Climate change threats to plant diversity in Europe. *Proc. Natl. Acad. Sci. U.S.A.* 102: 8245–8250.
- Torres-Carvajal, O. 2007. Phylogeny and biogeography of a large radiation of Andean lizards (*Iguania*, *Stenocercus*). *Zool. Scripta* 36: 311–326.
- Troll, C. 1968. The cordilleras of the tropical Americas: Aspects of climatic, phytogeographical and agrarian ecology. *Colloq. Geogr.* 9: 15–56.
- Tubiello, F. N., J.-F. Soussana & S. M. Howden. 2007. Crop and pasture response to climate change. *Proc. Natl. Acad. Sci. U.S.A.* 104: 19686–19690.
- Turner, M. G. 2005. Landscape ecology: What is the state of the science? *Ann. Rev. Ecol. Syst.* 36: 319–344.
- Vanbergen, A. J., A. D. Watt, R. Mitchell, A.-M. Truscott, S. C. F. Palmer, E. Ivits, P. Eggleton, T. H. Jones & J. P. Sousa. 2007. Scale-specific correlations between habitat heterogeneity and soil fauna diversity along a landscape structure gradient. *Oecologia* 153: 713–725.
- Van Dyke, F., J. D. Schmeling, S. Starckenburg, S. Heun Yoo & P. W. Stewart. 2007. Responses of plant and bird communities to prescribed burning in tallgrass prairies. *Biodivers. & Conservation* 16: 827–839.

- Veblen, T. T., K. R. Young & A. R. Orme (editors). 2007. *The Physical Geography of South America*. Oxford University Press, Oxford.
- Velázquez, E. & A. Gómez-Sal. 2007. Environmental control of early succession on a large landslide in a tropical dry ecosystem (Casita volcano, Nicaragua). *Biotropica* 35: 601–609.
- Vilímek, V., M. L. Zapata, J. Klimeš, Z. Patzelt & N. Santillán. 2005. Influence of glacial retreat on natural hazards of the Palcacocha Lake area, Peru. *Landslides* 2: 107–115.
- Vitousek, P. M. 2004. *Nutrient Cycling and Limitation: Hawai'i as a Model System*. Princeton University Press, Princeton.
- Vuille, M., R. S. Bradley, M. Werner & F. Keimig. 2003. 20th century climate change in the tropical Andes: Observations and model results. *Clim. Change* 59: 75–99.
- Wardle, D. A. 2002. *Communities and Ecosystems: Linking the Aboveground and Belowground Components*. Princeton University Press, Princeton.
- Wilcox, C., B. J. Cairns & H. P. Possingham. 2006. The role of habitat disturbance and recovery in metapopulation persistence. *Ecology* 87: 855–863.
- Williams, J. W., S. T. Jackson & J. E. Kutzbach. 2007. Projected distributions of novel and disappearing climates by 2100 AD. *Proc. Natl. Acad. Sci. U.S.A.* 104: 5738–5742.
- Young, K. R. 1997. Wildlife conservation in the cultural landscapes of the central Andes. *Landscape Urb. Planning* 38: 137–147.
- . 1998. Deforestation in landscapes with humid forests in the central Andes: Patterns and processes. Pp. 75–99 in K. S. Zimmerer & K. R. Young (editors), *Nature's Geography: New Lessons for Conservation in Developing Countries*. University of Wisconsin Press, Madison.
- . 2002. Minding the children: Knowledge transfer and the future of sustainable agriculture. *Conservation Biol.* 16: 855–856.
- . 2005. Andes. Pp. 47–50 in H. Geist (editor), *Our Earth's Changing Land: An Encyclopedia of Land-Use and Land-Cover Change*. Greenwood Publishing, Westport, Connecticut.
- . 2007. Causality of current environmental change in tropical landscapes. *Geogr. Compass* 1: 1299–1314.
- . 2008. Stasis and flux in long-inhabited locales: Change in rural Andean landscapes. Pp. 11–32 in A. Millington & W. Jepson (editors), *Land-Change Science in the Tropics: Changing Agricultural Landscapes*. Springer, New York.
- & P. L. Keating. 2001. Remnant forests of Volcán Cotacachi, northern Ecuador. *Arctic Antarc. Alpine Res.* 33: 165–172.
- & R. J. Aspinall. 2006. Kaleidoscoping landscapes, shifting perspectives. *Profess. Geogr.* 58: 436–447.
- & J. K. Lipton. 2006. Adaptive governance and climate change in the tropical highlands of western South America. *Clim. Change* 78: 63–102.
- & B. León. 2009. Natural hazards in Peru: Causation and vulnerability. In E. Latrubesse (editor), *Natural Hazards and Human-Exacerbated Disasters in Latin America*. *Developments in Earth Surface Processes Series*, Vol. 13. Elsevier, Amsterdam.
- , C. Ulloa Ulloa, J. L. Luteyn & S. Knapp. 2002. Plant evolution and endemism in Andean South America: An introduction. *Bot. Rev.* 68: 4–21.
- , B. León, P. M. Jørgensen & C. Ulloa Ulloa. 2007. Tropical and subtropical landscapes of the Andes Mountains. Pp. 200–216 in T. T. Veblen, K. R. Young & A. R. Orme (editors), *The Physical Geography of South America*. Oxford University Press, Oxford.
- Zimmerer, K. S. 1996. *Changing Fortunes: Biodiversity and Peasant Livelihood in the Peruvian Andes*. University of California Press, Berkeley.
- . 1999. Overlapping patchworks of mountain agriculture in Peru and Bolivia: Toward a regional-global landscape model. *Human Ecol.* 27: 135–165.

APPLICATION OF SCIENCE TO PROTECTED AREA MANAGEMENT: OVERCOMING THE BARRIERS¹

Carolina Murcia² and Gustavo Kattan³

ABSTRACT

No other line of practice requires application of science more urgently than conservation. Here we explore several elements that must be put in place to establish lines of communication between scientists and managers of protected areas. First, it is necessary that scientists are aware of the information needs of managers, that they produce the relevant information, and that this information is available to managers. Second, it is necessary that managers not only know how to access, process, and incorporate the information, but that they also internalize their need for that science and the clear advantages of incorporating it into their practice. We propose several mechanisms to ensure an adequate flow of information between the two groups: active dialogue between the parties, translators of science located both in academia and government and nongovernmental organizations (NGOs), and execution of joint projects. In particular, we argue that science-oriented NGOs can play a major role in bridging the gap between basic science and on-the-ground conservation. We finish by describing three case studies in which some of these models have been explored in Colombia and how science has been applied to address conservation and management concerns.

Key words: Applied science, Colombia, conservation, management, nongovernment organizations.

“Science does not provide the solutions, but it can help understand the consequences of different choices.”

—Lubchenco (1998)

Science is expected to play a major role in informing and implementing decision-making processes that affect civil society, because science provides a rigorous and objective knowledge framework (May, 1998; Mills & Clark, 2001; Eagle et al., 2003; Manning, 2005; Roux et al., 2006). In this context, no other line of practice requires the application of science more urgently than the conservation of biodiversity, in which policies and decisions could have tremendous implications for all forms of life. Yet, the broken lines of communication to transfer this knowledge between scientists and conservation policy makers and managers is a permanent concern of parties involved in conservation worldwide (Pendergast et al., 1999; Stone, 2002; Pullin et al., 2004; Meijaard & Scheil, 2007). This concern is particularly worrisome in tropical developing countries, because they harbor the greatest proportion of biodiversity but lag behind developed countries, both in absolute and relative terms, in monetary resources and

highly trained scientists and managers. Lack of communication leaves valuable information trapped in specialized journals, with no application, and those making important decisions are deprived of critical information.

Scientific knowledge can be applied to the conservation and management of biodiversity at multiple levels along a great continuum—from the president and high-ranking politicians of a nation to the local park warden. Each level deals with issues that operate at different spatial scales, with different degrees of detail. The professional profiles of the users of scientific information are different, and so are the mechanisms for incorporating science into the decision-making process. Here we will focus on what we perceive as one of the most critical levels: the middle managers, in particular those involved in the management of protected areas. These managers are typically staff members in national or state government environmental agencies and are the people who make the day-to-day decisions on how to manage the parks; they are responsible for devising and implementing management plans for areas and species.

¹ We wish to acknowledge the Wildlife Conservation Society and The John D. and Catherine T. MacArthur Foundation for supporting the involvement of the authors in several of the processes described. The work presented here was also supported by the Colombian National Parks Unit and Corporación Autónoma Regional de Risaralda. This manuscript benefited from the comments of Javier Mendoza, Victoria C. Hollowell, Peter Jørgensen, and an anonymous reviewer.

² Fundación EcoAndina, AA 25527, Cali, Colombia, and Organization for Tropical Studies, Apartado 676-2050, San Pedro, Costa Rica. carolinamurcia01@gmail.com.

³ Fundación EcoAndina, AA 25527, Cali, Colombia, and Pontificia Universidad Javeriana, Departamento de Ciencias Naturales y Matemáticas, Cali, Colombia. gustavokattan@gmail.com.

doi: 10.3417/2008031

To incorporate scientific knowledge into the practice of conservation, several elements are necessary. First, the relevant knowledge needs to be available. This availability requires that scientists address specific conservation and management issues in their research, and that the information is accessible by managers. Second, managers must have some incentive, or mandate, to base their decisions on sound science. Third, managers need to have the training and the time to access the scientific literature, extract the relevant information, and incorporate it into their action plans, within an adaptive framework that would allow them to evaluate options, as well as revise and adjust their decisions. Finally, the two groups need to be able to communicate effectively, to ensure that information is properly applied, and to provide feedback to scientists on the information needs of decision makers and managers.

In this article, we explore whether these conditions are being met, identify the elements that condition the generation and use of information, explore how these elements are connected by information pathways and affected by external factors, and find the gaps. We also illustrate several case studies in Colombia in which science has been applied to conservation planning using different strategies. We argue that science-oriented nongovernmental organizations (NGOs) can play a major role in bridging the gap between basic science and on-the-ground conservation. Although this paper is based on our experience in Colombia, we believe that it reflects the reality of many other Latin American countries. We focus on the biological sciences, but the situation is likely to be similar for the social sciences.

INFORMATION NEEDS OF MANAGERS

There is a tremendous amount of scientific knowledge pertaining to biodiversity and conservation that is published in journals. This knowledge is valuable and potentially usable by the conservation community in developing countries. However, the successful application of this science to management needs to account for the following premises.

SITE SPECIFICITY

Conservation problems are site specific, involving unique biological landscapes, varied human cultures with their own local idiosyncrasies, and particular sets of economic conditions and interests. Ideally, solutions for a site's conservation problems should be devised using locally produced information, but few sites across the tropics have a local research program. One option is to extrapolate data from similar sites or

ecosystems, but that is not without risk. Doing so requires an in-depth knowledge of the particular ecosystems, landscapes, or organisms to which this information would apply, so that reasonably reliable predictions on how the system will respond can be made. The more ecologically different the sites are from those where data have been generated, the less reliable and effective that extrapolation will be. For example, extrapolating the impact of edge effects from what we know about lowland tropical rainforests in Amazonia to high-elevation humid forest in the Andes would be less accurate than an extrapolation to other lowland humid forest sites. Any extrapolation constitutes a working hypothesis that needs to be tested. Monitoring of any management implementation is a basic tenet of the concept of adaptive management, in which the results of the prescribed action are recorded and compared to the expected behavior, and corrective actions are taken to redirect the management to yield the desired effects (Walters & Holling, 1990; Johnson, 1999). Therefore, the application of science generated under different circumstances does require an additional component of monitoring.

CONSERVATION PROBLEMS PERSIST BEYOND THEORETICAL FADS

Some issues that are pertinent to management and conservation today were investigated several decades ago. However, before some key aspects were fully explored, scientists moved on to search for newer ideas and other knowledge frontiers. For example, subjects such as tropical secondary succession and gap dynamics were not studied in sufficient detail, and across different ecosystems and spatial and temporal scales, to give managers the adequate tools to address specific issues such as habitat restoration or the effects of selective logging. While some issues are being revisited under new conceptual frameworks (Guariguata, 1998; Chapman et al., 1999), numerous practical questions remain unanswered (Guariguata & Ostertag, 2002) and managers depend on those answers today to manage fragmented and disturbed landscapes. For example, how do wet tropical forests change during the middle to late successional stages (i.e., > 50 years old; Guariguata & Ostertag, 2002; Chazdon et al., 2007), and how long do the advanced successional stages last (Chazdon et al., 2007)? What is the average turnover rate for different tropical ecosystems? Given natural rates of disturbance and regeneration, what would be the minimum conservation area of a given tropical ecosystem to ensure long-term persistence? What are the successional patterns of different animal communities in middle to late successional stages? What are the barriers to

recolonization for different animal groups? If these questions remained unanswered for lowland wet tropical forests, where most tropical research occurs, there is less information for other ecosystems, such as dry, montane, or high-elevation ecosystems.

LONG-TERM COMMITMENT TO A SITE OR ISSUE

Many conservation problems require long-term or continued monitoring of a system to understand the nature of its internal dynamics. Such is the case of canopy trees that have supra-annual phenological patterns (Newstrom et al., 1994; Chapman et al., 1999) or of mammal and bird species with low fecundity and long life expectancy. Management plans that involve these species require information on the frequency of the flowering or fruiting events, plus some indication of the factors that trigger flowering or, in the case of the animals, the frequency of reproduction and number of reproductive years of an animal to estimate overall fecundity. Such information can be attained only after many years of monitoring. However, few sites in the tropics enjoy the benefits of a long-term research program. For example, Brazil, a country of 8 million km², has only 12 sites recognized by the International Long-term Ecological Research Network as long-term sites (<<http://www.icb.ufmg.br/peld/>>). Of those sites, only one is in the Amazon forest.

FACTORS THAT AFFECT THE GENERATION OF APPLIED RESEARCH

A survey conducted among conservation leaders found a general perception that academic research does not meet the needs of conservation practitioners (Meijaard & Scheil, 2007). The generation and application of science into management for conservation has two main elements: the scientist and the manager. Both are affected by a number of factors that modulate how the science is produced, transferred, and applied (Fig. 1). On the scientist's side, the factors that affect selection of research topics and where this research is published are: the sources of funding, the scientists' own intellectual interests, the scientists' institutional criteria for professional advancement, and the policies of publishers of scientific papers. On the manager's side, the factors that affect whether they access and apply science to their own decisions are: the policies from their own institutions regarding how much they expect science to be a part of the process and how many resources they provide managers to that end (e.g., time, funds, library access), their own training, and the sociopolitical context in which these decisions are made.

SELECTION OF RESEARCH TOPIC

Several internal and external factors affect how scientists choose the topics for their research. The first two factors are of a personal nature. First, and most obvious, is the researcher's own curiosity and passion to understand a specific system. While some researchers prefer to focus their research on more theoretical questions, others are increasingly more interested in addressing questions that could have direct application to conservation issues (e.g., see Kremen, 2005). The second motivation is professional advancement. Successful research on cutting-edge topics that generates many highly visible papers can be a significant boost for a career, involving promotions or better salaries. In public Colombian universities, a faculty member's salary within a given rank is determined in part by his or her publication record. Promotion to higher ranks is also determined by productivity. Thus, there is an incentive for searching for topics that can produce papers in top journals.

A third factor that affects topic selection is funding. Funds can come as grants from private donors or science government agencies or as contracts for commissioned work from environmental government agencies. Funding is also driven by fierce competition and by the priorities set by funding agencies and other donors. To secure funding from science funding agencies, proposals need to show how much science will be advanced. Thus, proposals that address cutting-edge issues and push the frontiers of science are more successful; however, Colciencias, the Colombian government research granting agency, requires a statement of social pertinence in proposals. Donors are likely to avoid sensitive questions that could generate bad press or conflict (Meijaard & Scheil, 2007). This tendency precludes research that addresses threats caused by highly visible or identifiable corporations. Donors also tend to shift their programmatic emphasis frequently enough to make it hard for scientists to sustain long-term monitoring or research. To ensure continuance of funding that would allow the compilation of long-term data, scientists must exhibit great ingenuity to keep presenting the same system under a novel conceptual light at each new funding cycle.

A more recent source of funding that has the potential to engage scientists in answering applied questions through research is through contracts with environmental government agencies. Although a rare occurrence, progressive regional environmental agencies in countries such as Colombia (e.g., as Corporación Autónoma Regional de Risaralda [CARDER], Corporación Autónoma Regional del Valle del Cauca

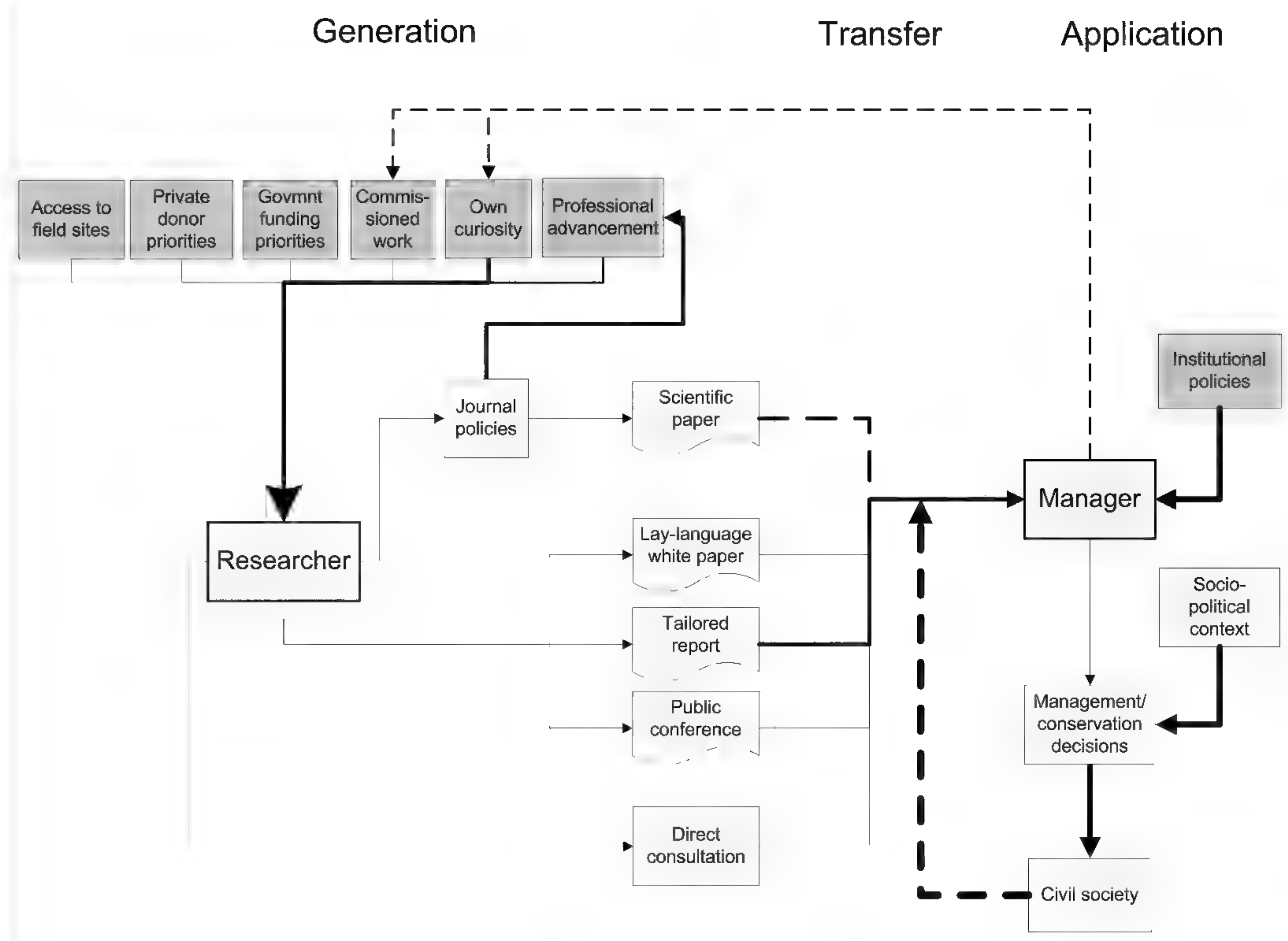

Figure 1. Pathways describing the three-step process of (1) generation of knowledge that may be applicable to management of protected areas, (2) transfer of knowledge, and (3) application of knowledge. The steps of generation and application are framed circumscribing the field of action of the two main actors (researcher and manager). In contrast, the second step (transfer) has been left intentionally without boundaries or an associated actor to illustrate that this is an area that is currently a no-man's-land, and that each actor expects that the other assumes the related responsibilities. Boxes in dark gray show the factors that affect each of the two actors. Line thickness illustrates our perceived strength of the relationship. Broken lines indicate weak links.

[CVC], Corantioquia) routinely outsource short-term research projects to address specific information needs.

Finally, limitations inherent to a field site also affect topic selection. To address conservation issues, scientists often need to work in protected areas, which involves obtaining research permits from the appropriate agencies. A lack of clear procedures by the environmental authority or highly complex processes makes it difficult to obtain these permits and discourages researchers from these areas and research topics. When issues involve local communities and several implementing agencies, two additional levels of complexity are added. Seeking agreement among actors, and accommodating their participation in the project, is a diplomatic art in which few scientists are trained, although a handful of new schools are gradually training scientists in these multidisciplinary, multicultural exercises (Gibbons et al., 1994). Interestingly, some private landowners have become

interested in having research conducted on their properties (e.g., for conserving populations of red howler monkey *Alouatta seniculus* L. in the Cauca Valley of Colombia; Valderrama & Kattan, 2006). Although these landowners do not derive a direct benefit and often contribute resources in-kind, their curiosity about their own systems opens this unexpected opportunity. The availability of a permit-free and conflict-free site, where sometimes the logistics are provided or facilitated, has recently lured a number of Colombian scientists to explore conservation and ecological issues in agroecosystems.

BRIDGING THE GAP BETWEEN SCIENCE AND MANAGEMENT

Scientists in general can become rather self-absorbed. Most scientists are trained in the tradition of defining research questions from within the academic domain (Gibbons et al., 1994). In this tradition, scientists often do not consult outside of

academia about the types of questions that are relevant to pursue. Instead, they are driven by the pursuit of objectivity, replicability, and rigor in the experimental design. This approach, while commendable, leaves scant room for scientists to investigate questions essential for other interest groups, such as conservation managers. A new trend defining the focus of science is emerging (Gibbons et al., 1994) and involves a more multidisciplinary approach that integrates the academic domain with the rest of the world, frames the question in a practical problem that needs a solution, and engages other actors in the formulation of questions. Although this model has potential risks (e.g., the researcher loses control of the project), it increases insight and applicability of the recovered information and also increases accountability to all parties involved.

Nevertheless, the burden of reaching out to the other party cannot be placed solely on the scientists' shoulders. Communication between scientists and managers has to flow in both directions, and managers need to reach out to scientists (Fig. 1). Managers in developed nations are already addressing the scientific community at their own forums (Ruth et al., 2003). Unfortunately, this is not happening yet in Latin America. There is a need to create a culture among managers to attend scientific meetings and address the scientific community to present their needs for information.

Funding agencies can also help to bridge this gap. By giving priority to proposals that have a significant applicable component, government funding agencies can stimulate intranational research that answers management questions. While funding research is not usually a priority for private donors, these donors are also playing a role in shaping the interests of scientists by funding research that is directly connected to conservation issues and has immediate application (Stone, 2002).

Although managers or government agencies typically have no money and therefore no influence on how research is focused, a few progressive government agencies in Colombia that have enough resources are commissioning work from scientists on specific topics. Usually, those contracts are geared toward the assessments of biodiversity or the conservation status of species or ecosystems. As such, they are not aimed at testing cutting-edge scientific hypotheses, but at generating information required for immediate application by the agency. However, some scientists are able to design their studies in a way that merges with hypothesis-testing exercises. In these cases, it is a win-win situation: the agency obtains the information it needs and the scientist obtains funding for publishable research.

CAN MANAGERS ACCESS AND USE SCIENTIFIC KNOWLEDGE?

Applying scientific information to management and conservation takes two distinct steps: the transfer of the information and the actual incorporation into management plans and actions. These steps have different limitations and potentially different actors. The first step begins with the scientists who produce documents that summarize the questions asked, the results, and the implications (theoretical or applied) of their results. Accessibility to the documents varies depending on the type of publication chosen by the scientist.

VENUES FOR PRESENTING RESEARCH RESULTS

Given a choice, scientists prefer to publish in prestigious journals (Aarssen et al., 2008) to advance academically or increase their salaries. Papers in high-impact journals bring visibility, access to more funding, and prestige. However, the collegial competition to get an article published in those journals has exponentially increased in the past few decades and has resulted in a narrowing of the editorial criteria for accepting manuscripts (Meffe, 2006; Aarssen et al., 2008). The competition among international scientific journals is fierce (Olden, 2007), and only manuscripts that appeal to the greater scientific audience may be accepted. Therefore, journals favor articles addressing cutting-edge issues that require a conceptual development of broad implications and new methods. In addition, journals may be especially biased against manuscripts with a local emphasis, written in languages other than English, or with descriptive or applied undertones (Meffe, 2006; Olden, 2007). While this may seem unfair at first glance, one must not lose sight of the fact that these journals are responding to market forces of a distinct sector of the scientific population: academics in developed countries (Lawler et al., 2006). Although the number of journals with an applied emphasis has increased exponentially in the past 20 years (Lawler et al., 2006), the applicability of research results to different sites, ecosystems, or situations that are not central to the articles has not necessarily increased (Stinchcombe et al., 2002; Pullin et al., 2004; Lawler et al., 2006; Armstrong & McCarthy, 2007). Nevertheless, the selection pressure generated by journals can reinforce a scientist's determination to focus on cutting-edge issues and stay away from more applied topics.

Less frequently, scientists produce reports in lay language, such as in white papers, working papers, or gray literature. Reports are usually the result of commissioned work and are tailored to suit specific needs of government agencies. These types of documents are assigned a lower value as intellectual

production in academic institutions because they are not peer-reviewed documents. In addition, scientists require special skills to communicate effectively to a general audience. Therefore, there is little incentive for this type of work, except perhaps as extra income.

Faculty are often invited to present their research to general audiences as guest speakers of public events, and this makes some of their research accessible to managers. However, this is often an opportunistic activity and not part of a concerted effort to systematically transfer the information to the conservation practitioners. Often, the interaction with the scientist ends at the end of the talk.

ACCESSIBILITY OF THE INFORMATION

Once the information is published, in theory it is available for people to use; in Latin America, however, this is not a valid assumption. Managers of protected areas in Latin America typically have a professional degree (B.Sc. or B.A. equivalents) and have limited exposure to scientific research. While many are trained in biology or related disciplines, a large proportion have engineering, administration, or social sciences backgrounds. Normally, parks have management plans that outline strategies to address their particular problems, but managers may have to take specific actions in their day-to-day jobs, ideally informed by science. Park managers face a myriad of conservation problems. For many of these issues, there may be sufficient research published in scientific journals that addresses these problems from theoretical or practical perspectives, but this does not resolve the question of how a manager locates and identifies the relevant information and applies it to specific cases.

The first barrier faced by the manager is time to conduct a literature search. This issue affects managers even in developed countries (Pullin et al., 2004). Government agencies are usually understaffed, and their managers are overcommitted. Therefore, there is little time to devote to an activity that, by its very nature, is time-consuming. Although web-based, free tools such as Google Scholar (<<http://scholar.google.com/>>) have made literature searches much easier, managers still require time to read through the potentially hundreds of results for any particular query.

Information needs to be accessible—physically, linguistically, and conceptually. Physical accessibility has improved in the past decade. The widespread use of the Internet has lessened the physical gap between readers and journals, with information theoretically at anyone's fingertips. Although most electronic journal subscriptions remain expensive, managers in Colombia find their way around this obstacle by requesting articles directly from the authors or by obtaining them

from colleagues with better library access. Posting articles on authors' web pages certainly facilitates fast access to many papers.

The second component of accessibility is language. Most scientific papers are written in English, and Latin American managers are rarely fluent in this language. A survey of the conservation-relevant scientific literature produced in Indonesia since 1884 (284 documents, including 81 from the gray literature) showed that only four articles were in Indonesian, 95% were in English, and the rest were in Dutch, French, and German (Meijaard & Scheil, 2007). In time, electronic publishing should make the publishing of papers in different languages affordable.

The third component is the specialized language used in the scientific literature. A manager who is starting to learn about a specific topic faces the challenge of learning a new vocabulary, new concepts, and new methods. Costs of publishing have forced journals and authors to compress papers, thus limiting explanations to those uninitiated in the field. Clearly, managers in Latin America and other non-English-speaking, developing countries require a medium of communication that eliminates all of these barriers.

PROCESSING AND EXTRAPOLATION OF SCIENTIFIC INFORMATION

Assuming the barrier of accessibility is solved, managers need to process the information and extrapolate it to adjust it to the local conditions of their site. Managers usually receive complementary on-the-job training to improve their administrative skills and broaden their capacity to tackle a diverse array of problems. Courses may include tools for management, such as business or natural resources administration, conflict resolution, or social sciences. None of these courses improve the manager's skills to survey the scientific literature in conservation biology, much less to critically assess what is most relevant or best qualified for their particular area or situation. These limitations are solvable, but this solution requires the impetus of the government organizations and the political will of policymakers.

More importantly, managers must have a serious motivation to incorporate science into their decision making. At this time, there is no mandate that requires managers to do so. In some Colombian environmental institutions such as the National Parks Unit and several corporations (regional government environmental agencies), there has been some gradual effort to ensure that management decisions are based on solid scientific work, but it is frequently done without the resources and expertise required to do it properly. Large discrepancies exist among agencies and even countries as to the amount of science they incorporate in their work.

Although park siting still occurs in an opportunistic way in many countries, Mexico is now basing its conservation planning on an extensive nationwide database of biodiversity distributions. The next big step is to oversee that science is correctly applied.

In any market-based society, those who improve the quality of their product and its fit to society's needs are most likely to succeed. Concurrently, to the extent that managers incorporate science into their planning and decision making, they are more likely to yield a good product for the ultimate consumer: society at large. However, results-based incentives to incorporate science may take one or two generations to have an effect. The difference in the results between those who apply science and those who do not will not be apparent for several decades, and there is no time to waste. Therefore, we need to seek mechanisms that force a change in mindset among managers and decision makers, and at the same time provide the resources for managers to tap into the existing science.

THE NEED FOR A SCIENCE TRANSLATOR

Thus far, we have analyzed some aspects of knowledge generation and application, but there is one issue that requires further analysis. Whose responsibility is it to ensure that science is transferred? Is it the scientists' or the managers' responsibility to do such translation (Stone, 2002)? Currently, both groups are suffering from overextending their reach. Scientists often struggle with guilt that they are not sufficiently reaching out to other groups to ensure that their science is applied (Whitten et al., 2001), but they rarely have the time, mechanisms, or training to do so. A few scientists, such as E. O. Wilson or Bernd Heinrich, are blessed with the natural ability to communicate outside of their particular academic circle. Ironically, these scientists commonly reach out to the general public, but rarely to the managers and policy makers, perhaps because of differences in receptivity among these groups. As we have seen, managers are also overextended and lack the training to find, read, process, and synthesize the literature to apply it to specific circumstances. Even in countries such as the United Kingdom, managers tend to rely on other sources of information, rather than the primary scientific literature, to develop their management plans (Pullin et al., 2004).

We propose that there is a need for a science translator to bridge that gap; such an individual could be housed either in scientific institutions (as an outreach element) or in government organizations or science-oriented NGOs (as an official science translator and liaison with academia). To this end, a number of non-mutually exclusive mechanisms can

be devised to ensure proper transfer of science into policy and management:

1. Management organizations create an internal position of science advisor or coordinator. The primary responsibilities of this position would be to ensure that the most critically needed research is conducted in-house (in association with universities, research institutes, and research NGOs) and that the results of this and other research produced outside (i.e., in other systems or countries) are incorporated into management plans.
2. Management organizations hire consultants—on a need-to-know basis—among the scientific community to address specific issues.
3. Management organizations team with universities and NGOs and jointly develop a research agenda or policy documents that incorporate science into planning and action.
4. Management organizations form consortia with universities, research institutes, and research NGOs to address specific conservation or management issues.
5. Professional organizations, academia, or NGOs conduct training and discussion workshops that bring scientists and managers together. The goal of these workshops would be to bring new scientific advances to the attention of managers and to provide an opportunity for managers to indicate to scientists the types of issues for which they need information.
6. University professors steer graduate students toward conducting applied research in concert with government agencies and NGOs.

Variations of some of these models have been successfully tried in Colombia. We will describe three case studies in which such efforts are being made with a remarkable positive effect on the quality of the conservation decisions made later.

CASE STUDY 1: ASSESSMENT OF INFORMATION AVAILABILITY AND NEEDS IN THE COLOMBIAN NATIONAL PARKS

In 2000, the Colombian National Parks Unit commissioned the design of a research strategy in conservation biology that addressed the needs of protected areas (Kattan & Murcia, 2001; a parallel process was conducted for social sciences). This strategy was accomplished in two phases: a diagnostic phase and a collective construction phase. The diagnostic phase involved assessing the scientific information available and its accessibility, as well as the infrastructure available for conducting research in national parks. The collective construction phase involved two components: (1) a training workshop to

update area managers from all the parks in key concepts of conservation biology and (2) a series of exercises to determine the most urgent information needs to address the most critical threats in their parks.

The information diagnostics evaluated the historic output of research produced in the Colombian National Parks between 1975 and 2000. A total of 726 documents representing scientific papers (published in national or international journals) as well as gray literature (theses and technical reports) were analyzed. Of these documents, 91% fell into the category of basic research, 8% assessed effects of human activities, and 1% addressed restoration of species and ecosystems.

We also evaluated the accessibility of the documents. All reports were stored in a main library at the National Parks Unit headquarters in Bogotá, but the collection of theses and other documents was incomplete at this library. Half of the published documents were accessible because they were in local journals or in international journals with wide distributions in Colombia. The remaining half were published in international journals that were not easily accessible in Colombia. Half of the papers were in Spanish, the remainder were in English, and one was in German.

From the parks-wide consultation for the types of management issues that they were facing, park staff identified seven main themes that urgently required research:

1. Basic information on composition, structure, and dynamics of key animal and plant communities (mainly vertebrates and some invertebrates for marine ecosystems) and on the dominant ecosystems in each park
2. Basic information on habitat use, habitat availability, population status assessments, and demographics of focal (flagship, endemic, and threatened) species
3. Rates of transformation of landscapes and ecosystems
4. Impact of resource extraction (timber and nontimber products, wildlife, and mining)
5. Carrying capacities of the systems to sustain ecotourism
6. Impact of external threats such as development projects in the immediate vicinity of the parks
7. Restoration (guidelines, protocols, and species recommended)

This exercise revealed that the range of issues faced by the parks is wide and covered almost all of the current issues addressed in conservation biology at the supraorganism level. The information available at the time was not sufficient to address those issues (research output was an average of 0.6 articles per park per year). There was a dramatic decoupling

between what was being researched and what the managers needed. Only the first category (basic information on communities and ecosystems) was being partially met, because there was little information on dynamic processes at the community and ecosystem level. Accessibility of the information needed to be addressed by ensuring that all researchers turned over the products of their investigations and that the main and regional libraries were fully stocked with copies of these documents.

As part of this activity, 40 Colombian park managers received their first-ever training in basic principles of conservation biology. This training allowed them to put their management concerns in current conceptual frameworks and increased their understanding of jargon and concepts in the literature. The training also familiarized them with a selection of classic scientific papers that had become common knowledge for the average biology student in the country but were not accessible to the managers.

The following recommendations ensued from this consultation:

1. Create a full-time position of scientific coordinator (preferably Ph.D. level) within the parks unit who would define research priorities and serve as a science translator for the managers. This position could be either a permanent employee of the unit or a position filled by university faculty who would serve two- to three-year service cycles.
2. Develop an outreach policy to engage university faculty with conservation expertise in planning and management consultations. Alliances with universities and research NGOs will be necessary.
3. Streamline and clarify the process to grant research permits.
4. Develop a more efficient way to recover, store, and access the information produced by scientists in the national parks of Colombia.
5. Improve facilities to attract scientists to conduct research that is relevant to the parks.
6. Create several research stations in selected national parks.
7. Change the National Parks Unit policy to include research as one of its mandates.

Eight years later, some of these recommendations have been put into place. Research is now recognized as a more important activity, there is a science coordinator position (but not at the Ph.D. level), several national parks have research stations being run in coordination with other organizations, there are clearer procedures in place for processing research permits, and academics and other scientists are often invited by the parks unit to participate in defining new management plans.

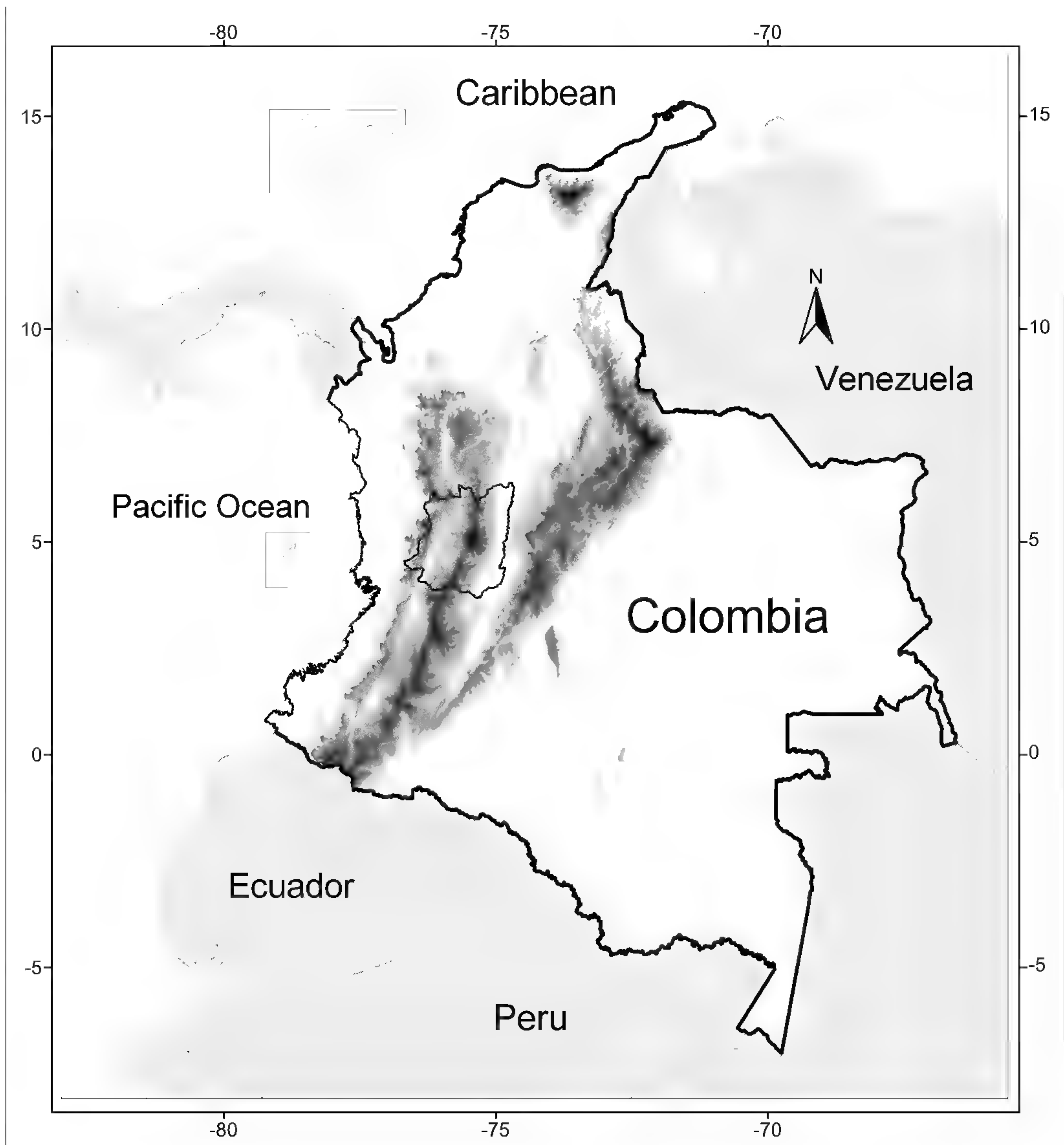

Figure 2. Topographic map of Colombia showing the location of the SIRAP Eje Cafetero (dark line).

CASE STUDY 2: DIRECT APPLICATION OF SCIENCE TO CONSERVATION PLANNING: THE CASE OF THE SIRAP EJE CAFETERO

One of the commitments acquired by the Colombian government in the Rio Convention was the creation of a national network of protected areas (Sistema Nacional de Áreas Protegidas [SINAP]). Colombia chose to do so in a modular fashion, with the creation of regional systems of protected areas (Sistema Regional de Áreas Protegidas [SIRAP]) that would

eventually make up the nationwide network. The first region to take on this task in 2000 was the Eje Cafetero (EC), the coffee-growing region located in central Colombia (Fig. 2). This area is 30,000 km² and encompasses portions of two Andean ranges and two inter-Andean valleys, as well as the core of the coffee-growing landscape of the country. Middle elevations (1200–1800 m) of this highly productive agricultural landscape include coffee plantations (shaded and nonshaded), pastures (for small-scale, intensive cattle ranching), other minor crops (mostly

fruits and vegetables), and forest remnants, as well as four provincial capitals (each with 300,000 to 750,000 inhabitants) and small towns. Although the area is called the Eje Cafetero, land use in the lower elevations (below 1200 m) includes cattle ranching and crops such as sugar cane. Upper elevations are less populated, and only a few crops, such as potatoes, and cattle ranching constitute the agricultural element. The rest of the area is covered with forest remnants, páramo (high Andean alpine-type vegetation), snowcaps, and exposed soil above the tree line. The rich volcanic soils and pleasant weather have sustained a dense population since pre-Columbian times, and the region is currently traversed by numerous roads that connect a prosperous network of rural settlements. In this context, the original forest has been reduced to a lattice of forest fragments, relegated mostly to elevations above 2000 m. Less than 10% of the original forest is now protected within three national parks and a few regional and municipal protected areas. The general objectives of the SIRAP-EC project were to increase the area under protection and, by doing so, to conserve a representative and viable sample of the region's original biodiversity (Kattan, 2005, 2006).

To accomplish this, a consortium of 12 institutions including five regional government environmental agencies (called Regional Autonomous Corporations in Colombia), the National Parks Unit, the Humboldt Institute (the national biodiversity institute), three Colombian NGOs, and two international NGOs was formed. Three NGOs (Fundación EcoAndina, Wildlife Conservation Society [WCS], and World Wildlife Fund [WWF]) led this consortium on the technical aspects of the biological planning phase. This phase involved: (1) defining the goals and objectives of the SIRAP-EC (i.e., defining what and how much we wish to conserve), (2) compiling spatial information and generating potential and current vegetation maps, (3) compiling a database of all biodiversity records in the region, (4) conducting biological information and conservation gap analyses as well as some rapid biodiversity inventories, and (5) recommending new protected areas.

This work was collaborative and all of the aforementioned organizations actively participated in the workshops and meetings. However, different organizations played different roles: EcoAndina, WCS, and WWF were in charge of conceptually steering the biological planning phase, compiling the information, performing the analyses, conducting a consultative process with experts, and proposing management strategies to gain functional regional connectivity. The WWF provided the training in geographic information system (GIS) to technicians at the corporations and NGOs, conducted some of the GIS analyses, and

supervised the final GIS steps. The role of the government organizations was to coordinate the project, steer the project in the social and political arenas, process the geographic information in their areas (under WWF's supervision), assist in the collection of biological information, link the SIRAP-EC to other regional processes (e.g., ecoregional planning, social initiatives, disaster prevention, and the SINAP), and generate support in the process at high levels of regional and national decision making in preparation for the final proposal of protected areas. In addition, experts from different universities, NGOs, and other government institutions were asked to contribute to several planning workshops, or hired to prepare some of the sociological analyses that framed the SIRAP-EC. The vision, project goals, selection process of candidate areas and focal species, and identification of key conservation areas were generated collectively by all of the organizations in a consultative exercise that also involved national and regional scientists.

Some accomplishments of this process include the following:

1. A proposal to increase the cover of protected areas in the region of the EC, based on the four-R principle: representation, resilience, redundancy, and restoration (Groves, 2003: 30–33). Sixty-four additional areas were selected for conservation that would increase the area under protection from 200,000–700,000 ha. (or approximately 23% of the region). Several areas have already been granted protected status. This component incorporated the latest scientific advances in reserve network design.
2. Development of management plans for focal species. Initially, seven species were selected for developing science-based management plans. The first two, the Cauca guan (*Penelope perspicax* Bangs) and the red howler monkey (*Alouatta seniculus* L.), now have management plans that are based on research conducted by Fundación EcoAndina–WCS on population status, habitat requirements, and availability, as well as their current distribution through their geographic and ecological ranges (Kattan & Valderrama, 2006; Valderrama & Kattan, 2006). The management plans have geographically explicit conservation goals with assessment of direct and indirect threats. The plans also contain a sociopolitical analysis with opportunities for carrying out the proposed activities.
3. Development of preliminary management plans for 18 additional vertebrate species in one of the provinces (Valle del Cauca) for which less information is available. These species include the multicolored tanager (*Chlorochryssa nitidis-*

sima Scletter), which is endemic to west-central Colombia, and the pacarana (*Dinomys branickii* Peters), a unique Andean rodent.

4. Updating of management plans for already-established protected areas and their surrounding landscapes. In the case of the Otun watershed, the management plan was expanded to a regional scale. Two corporations (CVC and CARDER) have commissioned research projects to produce information for the updating of management plans.

These processes involved the incorporation of conservation biology concepts ranging from island biogeography and fragmentation to metapopulation ecology and habitat restoration. This was accomplished through a series of workshops in principles of conservation biology that apply to the design of networks of protected areas and through the production of educational materials (e.g., Kattan & Naranjo, 2008). In addition, GIS technicians from all of the participant government organizations received training on satellite image analysis and classification.

An offshoot of this process was the transference of science to other regional planning exercises in Colombia. One example is the Sistema Departamental de Áreas Protegidas (SIDAP) Sonsón, a province-level network of protected areas for the southern portion of Antioquia. Here, government organizations led the process, using the SIRAP-EC as a template, and EcoAndina–WCS assisted the process by preparing a habitat model for the spectacled bear (*Tremarctos ornatus* F. G. Cuvier, the animal with the largest habitat requirements), which served as a planning tool to define conservation priorities.

CASE STUDY 3: CONSORTIUMS OF ORGANIZATIONS THAT PROMOTE COMMUNICATION: THE CASE OF REDBIO

A third model that has proved successful in transferring science to practice is Red de Investigación en Biodiversidad y Conservación (REDBIO), which is a consortium of 25 organizations including national and regional government organizations, NGOs, and universities from western Colombia that was created in 2002. The consortium's main objectives are to promote communication, share experiences, and foster research and conservation projects. In its six years of activity, REDBIO has organized annual regional symposia on research and conservation of biodiversity. These symposia provide a showcase for ongoing research conducted in the region and are well attended by local researchers, NGOs, and protected area managers. REDBIO has also organized several courses and joined forces with Universidad de Antioquia, Colombia, to offer a graduate degree in protected areas for staff from

parks, corporations, and NGOs. In addition, all partner organizations collectively compile a database on regional biodiversity that is accessible to all.

FACILITATION IS THE KEY: THE ROLE OF INDIVIDUALS AND NGOS

The current transfer of science in Colombia is happening as a result of changes in the human and institutional dimensions. There is now a synergistic partnership between the government and NGOs. Government organizations have discovered the benefits that result from these partnerships and are increasingly engaging those in academia and civil society as advisors and contributors to the planning processes. This development is due in part to a number of highly committed individuals who, through their careers, have moved between government organizations, NGOs, and academia; because of their professional experience and mobility, they have created networks of connections in which they act as mobile links.

A key element in this synergism is the emergence of local, science-oriented NGOs that generate original research and usually work in collaboration with conservation agencies. These NGOs conduct research that addresses conservation needs. Although they face several of the same challenges as academics when it comes to raising funds, they are less pressured to publish in prestigious international journals. Thus, they have more freedom to choose their research questions and to focus on those that are most relevant to local conservation. They also produce materials that synthesize current knowledge on certain issues, and by participating in planning and other conservation action processes, they assist in the transfer of science to the government agencies. These NGOs are sensitive to local needs and have the flexibility to adapt their agendas to serve those needs. They are also committed in the long-term to sites or regions, and this allows them to collect data over a long period. This commitment is vital for understanding the responses of ecosystems and species to stressors and to monitor the impact of management practices. However, NGOs depend on money from grants and donors, which makes them fragile (Dour-jeanni, 2006). Therefore, special efforts should be placed on strengthening national NGOs, because they can play a significant role in improving the transfer of basic science into actual conservation practice.

CONCLUSIONS

Environmental problems abound, and some are already sufficiently advanced to create effects of global proportions. Therefore, conservation practice must make use of all the information available to

curtail and potentially reverse the negative effects of human practices. This huge task cannot fall on the shoulders of scientists or managers alone. It requires an integrated approach in which all parties involved—governments, scientists, NGOs, donors, the media, scientific journals, and the general public—join forces to ensure that the relevant information is generated and applied in creative and bold ways.

Elsewhere, there are already a number of different mechanisms in place that allow the application of science to decision making, planning, and implementation of conservation (e.g., the Science and Technology Awareness Network of Canada). These mechanisms can be adapted and should be disseminated throughout the developing world. To do so requires strengthening organizations, particularly those at the national level, that are already serving as translators of science into practice, fostering the creation of new organizations that can serve in this role, mandating governments to incorporate science into their work, and further involving NGOs and academia in planning and decision-making processes.

Notwithstanding, there is a need for government organizations to strengthen their own staff so that they can directly access and apply science. To the extent that government officers embrace the notion that it is important to apply scientific evidence and methodologies to their decisions, the transfer of this science will occur more frequently and effectively. This will only happen when there is a minimal, basic level of understanding of how science can be applied within these organizations.

Although budgetary restrictions are a constant in government organizations in developing countries, local experience shows that even small investments can produce valuable information. In addition, communication among those who generate the science and those who should apply it requires little monetary investment and can yield impressive returns.

Literature Cited

- Aarssen, L. W., T. Tregenza, A. E. Budden, C. J. Lortie, J. Koricheva & R. Leimu. 2008. Bang for your buck: Rejection rates and impact factors in ecological journals. *Open Ecol. J.* 1: 14–19.
- Armstrong, D. P. & M. A. McCarthy. 2007. Big decisions and sparse data: Adapting scientific publishing to the needs of practical conservation. *Avian Conserv. Ecol.* 2: 14. <<http://www.ace-eco.org/vol2/iss2/art14/>>, accessed 5 May 2009.
- Chapman, C. A., R. W. Wrangham, L. J. Chapman, D. K. Kennard & A. E. Zanne. 1999. Fruit and flower phenology at two sites in Kibale National Park, Uganda. *J. Trop. Ecol.* 15: 189–211.
- Chazdon, R. L., S. G. Letcher, M. van Breugel, M. Martínez-Ramos, F. Bongers & B. Finegan. 2007. Rates of change in tree communities of secondary Neotropical forests following major disturbances. *Philos. Trans. Ser. B* 362: 273–289.
- Dourojeanni, M. J. 2006. ¿Organizaciones no gubernamentales internacionales o “transnacionales”? *Ecol. Aplic.* 5: 157–166.
- Eagle, K. A., A. J. Garson Jr., G. A. Beller & C. Sennett. 2003. Closing the gap between science and practice: The need for professional leadership. *Health Affairs* 22: 196–201.
- Gibbons, M., C. Limoges, H. Nowotny, S. Schwartzman, P. Scott & M. Trow. 1994. *The New Production of Knowledge: The Dynamics of Science and Research in Contemporary Societies*. Sage Publications, London.
- Groves, C. R. 2003. *Drafting a Conservation Blueprint: A Practitioner’s Guide to Planning for Biodiversity*. Island Press, Washington, D.C.
- Guariguata, M. R. 1998. *Consideraciones Ecológicas sobre la Regeneración Natural Aplicada al Manejo Forestal*. CATIE, Turrialba, Costa Rica.
- & R. Ostertag. 2002. Sucesión secundaria. Pp. 591–623 in M. R. Guariguata & G. H. Kattan (editors), *Ecología y Conservación de Bosques Neotropicales*. Libro Universitario Regional, Cartago, Costa Rica.
- Johnson, B. L. 1999. The role of adaptive management as an operational approach for resource management agencies. *Conserv. Ecol.* 3: 8. <<http://www.consecol.org/vol3/iss2/art8/>>, accessed 5 May 2009.
- Kattan, G. 2005. Planificando el Edén: Principios fundamentales en el diseño de sistemas regionales de áreas protegidas. Pp. 51–80 in N. Arango (editor), *Bases para el Diseño de Sistemas Regionales de Áreas Protegidas*. Instituto de Investigación de Recursos Biológicos Alexander von Humboldt, Bogotá.
- . 2006. Reconciling theory and practice in designing a regional reserve system: A Colombian case study. Pp. 548–550 in M. J. Groom, G. K. Meffe & C. R. Carroll (editors), *Principles of Conservation Biology*. Sinauer Associates, Sunderland, Massachusetts.
- & C. Murcia. 2001. *Desarrollo de una Estrategia de Investigación en Biología de la Conservación en el Sistema de Parques Nacionales Naturales*. Unidad de Parques Nacionales de Colombia, Bogotá.
- & C. Valderrama (editors). 2006. *Plan de Conservación de la Pava Caucana (Penelope perspicax)*. Instituto de Investigación de Recursos Biológicos Alexander von Humboldt and Fundación EcoAndina/Wildlife Conservation Society, Bogotá.
- & L. G. Naranjo. 2008. *Regiones Biodiversas: Herramientas para la Planificación de Sistemas Regionales de Áreas Protegidas*. Wildlife Conservation Society, EcoAndina, and World Wildlife Fund, Cali, Colombia.
- Kremen, C. 2005. Managing ecosystem services: What do we need to know about their ecology? *Ecol. Lett.* 8: 468–479.
- Lawler, J. J., J. E. Aukema, J. B. Grant, B. S. Halpern, P. Kareiva, C. R. Nelson, K. Ohleth, J. D. Olden, M. A. Schlaepfer, B. R. Silliman & P. Zaradic. 2006. Conservation science: A 20-year report card. *Frontiers Ecol. Environm.* 4: 473–480.
- Lubchenco, J. 1998. Entering the century of the environment: A new social contract for science. *Science* 279: 491–497.
- Manning, P. 2005. Bridging the communications gap between the science and non-science worlds. Science and Technology Network Conference, Toronto, Canada. <<http://www.scienceandtechnologynetwork.ca/main/downloads/Preston.pdf>>, accessed 5 May 2009.
- May, R. M. 1998. The scientific investment of nations. *Science* 281: 49–51.
- Meffe, G. K. 2006. The success—and challenges—of conservation biology. *Conserv. Biol.* 20: 931–933.

- Meijaard, E. & D. Scheil. 2007. Is wildlife research useful for wildlife conservation in the tropics? A review for Borneo with global implications. *Biodivers. Conserv.* 16: 3053–3065.
- Mills, T. J. & R. N. Clark. 2001. Roles of research scientists in natural resource decision-making. *Forest Ecol. Managem.* 153: 189–198.
- Newstrom, L. E., G. W. Frankie, H. G. Baker & R. K. Colwell. 1994. Diversity of long-term flowering patterns. Pp. 142–160 in L. A. McDade, K. S. Bawa, H. A. Hespenhide & G. S. Hartshorn (editors), *La Selva: Ecology and Natural History of a Neotropical Rain Forest*. University of Chicago Press, Chicago.
- Olden, J. D. 2007. How do ecological journals stack up? Ranking of scientific quality according to the h index. *Ecoscience* 14: 370–376.
- Pendergast, J. R., R. M. Quinn & J. H. Lawton. 1999. The gaps between theory and practice in selecting nature reserves. *Conserv. Biol.* 13: 484–492.
- Pullin, A. S., T. M. Knight, D. A. Stone & K. Charman. 2004. Do conservation managers use scientific evidence to support their decision-making? *Biol. Conserv.* 119: 245–252.
- Roux, D. J., K. H. Rogers, H. C. Biggs, P. J. Ashton & A. Sergeant. 2006. Bridging the science–management divide: Moving from unidirectional knowledge transfer to knowledge interfacing and sharing. *Ecol. Soc.* 11: 4. <<http://www.ecologyandsociety.org/vol11/iss1/art4>>, accessed 5 May 2009.
- Ruth, J. M., D. R. Petit, J. R. Sauer, M. D. Samuel, F. A. Johnson, M. D. Fornwall, C. E. Korschgen & J. P. Bennett. 2003. Science for avian conservation: Priorities for the new millennium. *Auk* 120: 204–211.
- Stinchcombe, J., L. C. Moyle, B. R. Hudgens, P. L. Bloch, S. Chinnadurai & W. F. Morris. 2002. The influence of the academic conservation biology literature on endangered species recovery planning. *Conserv. Ecol.* 6: 15. <<http://www.consecol.org/vol6/iss2/art15>>, accessed 5 May 2009.
- Stone, D. 2002. Using knowledge: The dilemmas of ‘bridging research and policy.’ *Compare* 32: 285–296.
- Valderrama, C. & G. Kattan (editors). 2006. Plan de Conservación del Mono Aullador (*Alouatta seniculus*) en la Región del SIRAP-EC y Valle del Cauca. Instituto de Investigación de Recursos Biológicos Alexander von Humboldt and Fundación EcoAndina/Wildlife Conservation Society, Bogotá.
- Walters, C. J. & C. S. Holling. 1990. Large-scale management experiments and learning by doing. *Ecology* 71: 2060–2068.
- Whitten, T., D. Holmes & K. MacKinnon. 2001. Conservation biology: A displacement behavior for academia. *Conserv. Biol.* 15: 1–3.

www.mbgpress.org

CONTENTS

Biodiversity and Conservation in the Andes: Introduction	<i>Peter Møller Jørgensen</i>	369
The Andes: A Geological Overview from a Biological Perspective	<i>Alan Graham</i>	371
Climate in the Dry Central Andes over Geologic, Millennial, and Interannual Timescales <i>Christa Placzek, Jay Quade, Julio L. Betancourt, P. Jonathan Patchett, Jason A. Rech, Claudio Latorre, Ari Matmon, Camille Holmgren & Nathan B. English</i>		386
Diversification of the South American Avifauna: Patterns and Implications for Conservation in the Andes	<i>Jon Fjeldså & Martin Irestedt</i>	398
Implications of Genetic Differentiation in Neotropical Montane Forest Birds	<i>Jason T. Weir</i>	410
Moss Diversity and Endemism of the Tropical Andes	<i>Steven P. Churchill</i>	434
Andean Speciation and Vicariance in Neotropical <i>Macrocarpaea</i> (Gentianaceae–Helieae) <i>Lena Struwe, Scott Haag, Einar Heiberg & Jason R. Grant</i>		450
Determinants and Prediction of Broad-scale Plant Richness across the Western Neotropics <i>Trisha Distler, Peter M. Jørgensen, Alan Graham, Gerrit Davidse & Iván Jiménez</i>		470
Andean Land Use and Biodiversity: Humanized Landscapes in a Time of Change <i>Kenneth R. Young</i>		492
Application of Science to Protected Area Management: Overcoming the Barriers <i>Carolina Murcia & Gustavo Kattan</i>		508

Cover illustration. A sword-billed hummingbird (*Ensifera ensifera*) pollinating *Passiflora tarminiana*, drawn by Barbara Alongi.

Annals
of the
Missouri
Botanical
Garden
2009



Volume 96
Number 4

The Annals, published quarterly, contains papers, primarily in systematic botany, contributed from the Missouri Botanical Garden, St. Louis. Papers originating outside the Garden will also be accepted. All manuscripts are peer-reviewed by qualified, independent reviewers. Instructions to Authors are printed in the back of the last issue of each volume and are also available online at www.mbgpress.org.

Editorial Committee

Victoria C. Hollowell
Scientific Editor,
Missouri Botanical Garden

Beth Parada
Managing Editor,
Missouri Botanical Garden

Allison M. Brock
Associate Editor,
Missouri Botanical Garden

Tammy Charron
Editorial Assistant,
Missouri Botanical Garden

Cirri Moran
Press Coordinator,
Missouri Botanical Garden

Roy E. Gereau
Latin Editor,
Missouri Botanical Garden

Ihsan A. Al-Shehbaz
Missouri Botanical Garden

Gerrit Davidse
Missouri Botanical Garden

Peter Goldblatt
Missouri Botanical Garden

Gordon McPherson
Missouri Botanical Garden

Charlotte Taylor
Missouri Botanical Garden

Henk van der Werff
Missouri Botanical Garden

For subscription information contact ANNALS OF THE MISSOURI BOTANICAL GARDEN, % Allen Marketing & Management, P.O. Box 1897, Lawrence, KS 66044-8897. Subscription price for 2009 is \$175 per volume U.S., \$185 Canada & Mexico, \$210 all other countries. Four issues per volume. The journal *Novon* is included in the subscription price of the *Annals*.

annals@mobot.org (editorial queries)

<http://www.mbgpress.org>

The *Annals* are abstracted and/or indexed in AGRICOLA (through 1994), APT Online, BIOSIS®, CAB Abstract/Global Health databases, ingenta, ISI® databases, JSTOR, Research Alert®, and Sci Search®.

The full-text of ANNALS OF THE MISSOURI BOTANICAL GARDEN is available online through BioOne™ (<http://www.bioone.org>).

© Missouri Botanical Garden Press 2009

The mission of the Missouri Botanical Garden is to discover and share knowledge about plants and their environment, in order to preserve and enrich life.

© This paper meets the requirements of ANSI/NISO Z39.48-1992 (Permanence of Paper).

Volume 96
Number 4
2009

Annals
of the
Missouri
Botanical
Garden



A REVISION OF THE MALAGASY ENDEMIC *HELMIOPSIS*
(MALVACEAE S.L.)¹ Wendy L. Applequist²

ABSTRACT

A taxonomic revision of the endemic Malagasy genus *Helmiopsis* H. Perrier (Malvaceae s.l.) is presented, based on material that has been collected since the last complete revision by Arènes. Nine species and one subspecies are recognized, of which one species (*H. polyandra* Appleg.) and one subspecies (*H. hily* Arènes subsp. *boinensis* Appleg.) are newly described from Madagascar. Arènes' infrageneric taxonomy is simplified; two sections (section *Glandulipetalae* Arènes and section *Helmiopsis*) are recognized. The section *Glandulipetalae* is typified by *H. pseudopopulus* (Baill.) Capuron ex Arènes, and *H. inversa* H. Perrier, the type species for the genus, is lectotypified. *Dombeya rigida* Baill. is excluded from *Helmiopsis*. Preliminary conservation assessments using IUCN criteria indicate that most taxa are of potential conservation concern: four species native to the extreme north should be considered Vulnerable, and one species and one subspecies are considered Data Deficient but likely to be at risk.

Key words: *Dombeya*, *Helmiopsis*, IUCN Red List, Madagascar, Malvaceae.

Helmiopsis H. Perrier is among a considerable number of endemic Malagasy genera of Malvaceae s.l.; it was formerly placed in Sterculiaceae and may have affinities to genera such as *Dombeya* Cav. or *Nesogordonia* Baill. It is characterized by features including a lepidote indument on inflorescences, sepals, ovaries, petioles, and usually twigs and leaves; biseriate perianth with well-developed, not ligulate or appendiculate petals; usually apically winged ovules and seeds; short androecial corona, with groups of fertile stamens alternating with staminodes; and glandular sepals and often petals. At the time of the last complete taxonomic

revision (Arènes, 1959), little material was available, with four of the eight species and one variety described from a single specimen, and only a handful of collections available for most of the others. Many more specimens have since been collected, especially in the extreme north of Madagascar, to which several species are endemic. This additional material has enabled better understanding of the genuine range of morphological variation within the genus and of the geographic distribution of the more common species, both of which were underrepresented in Arènes' (1959) treatment. A revision is therefore presented in which nine species are

¹I thank the Muséum national d'Histoire naturelle (P) and the Parc Botanique et Zoologique de Tsimbazaza (TAN) and curators thereof for access to collections and for loan of specimens from P; P. P. Lowry II and P. B. Phillipson for hospitality at P and helpful discussion; R. Halse, M. Koopman, T. Charron, V. Hollowell, B. Parada, and A. Brock for helpful comments and editing; R. Gereau for help with the Latin diagnoses; B. Alongi for illustrating new taxa; F. Keusenkothen for computer assistance; and D. Bills and T. Distler for the maps.

²William L. Brown Center for Plant Genetic Resources, Missouri Botanical Garden, P.O. Box 299, St. Louis, Missouri 63166-0299, U.S.A. wendy.applequist@mobot.org.

doi: 10.3417/2007184

recognized; one species is newly described, and one more placed into synonymy.

TAXONOMIC HISTORY

Perrier de la Bâthie (1944) described *Helmiopsis* with a single species, *H. inversa* H. Perrier, and two named varieties (not validly published due to the lack of a Latin diagnosis, as required by Art. 36.1 of the International Code of Botanical Nomenclature [ICBN; McNeill et al., 2006]) from a total of four specimens he had collected in western Madagascar. Simultaneously, he described three new species of *Nesogordonia* Baill., the type of which had been doubtfully placed in Theaceae, and observed that the two genera were clearly related and both better referred to Sterculiaceae. Capuron (1952) proposed to transfer two species previously placed within *Dombeya* (*D. richardii* (Baill.) Baill., *D. pseudopopulus* Baill.) to *Helmiopsis*, though the new combinations were not validly published. He acknowledged Perrier's placement of *Helmiopsis* and *Nesogordonia* within Sterculiaceae, remarking on similarities between the wood of those genera and that of *Mansonia* J. R. Drumm. ex Prain (Sterculiaceae), while suggesting a possible affinity to Tiliaceae. Arènes (1956a, b, 1959) also recognized *Helmiopsis* as belonging to Sterculiaceae; that entire family is now included within Malvaceae s.l. (Bayer et al., 1999).

Helmiopsis was last treated in full by Arènes (1956a, b, 1959). Arènes (1956a) recognized only two species, one of them based upon one of Perrier's (1944) invalidly published varieties of *H. inversa*; he rejected Capuron's (1952) view that *Dombeya richardii* and *D. pseudopopulus* should be placed within *Helmiopsis*. However, Arènes (1956b) published a revision recognizing eight species, including both of Capuron's additions as well as two other former *Dombeya* species. He placed the newly described *H. hily* Arènes alone in subgenus *Phelmiosis* Arènes due to its reduced number of carpels and the remainder in subgenus *Mihelopsis* Arènes. Publication of the former subgenus automatically established the corresponding autonym of subgenus *Helmiopsis* for the subgenus including the type (necessarily *H. inversa*) under Article 22.3 of the ICBN (McNeill et al., 2006), and "subgen. *Mihelopsis*," by including that type, was not validly published under Article 22.2. Within that group, section *Nudipetalae* Arènes—again, not validly published—comprised four species with relatively narrow leaves, numerous stamens (15 to 30), and nonglandular petals, while section *Glandulipetalae* Arènes comprised three species, including *H. richardii* (Baill.) Capuron ex Arènes and *H. pseudopopulus* (Baill.) Capuron ex Arènes, which are characterized by broad leaves, normally 10

stamens, and \pm glandular petals. The latter group is confined to a few areas at the northern tip of Madagascar, whereas the remaining species are more broadly distributed.

Arènes (1959) renamed his infrageneric groups to conform to the rules of nomenclature, subgenus *Mihelopsis* and section *Nudipetalae* becoming subgenus and section *Helmiopsis*, respectively, and largely maintained the same treatment of species. In two works (Arènes, 1956a, 1959), he recognized the invalidly published *Helmiopsis inversa* var. *arenicola* H. Perrier as a distinct variety, while unfortunately never validating it. Barnett (1987) described a new northern species, *H. sphaerocarpa* L. C. Barnett, which has certain features unique within the genus (virtual absence of a seed wing, spheroid capsule) but clearly belongs to section *Glandulipetalae*.

Dorr (2001) has also recently transferred *Dombeya rigida* Baill. to *Helmiopsis*. *Dombeya rigida* and its apparent sister species, *D. linearifolia* Hochr., were treated by Arènes (1958, 1959) as *Dombeya* subsect. *Rigidae* Arènes, characterized by scorpioid cymes and glandular petals. Subsection *Rigidae* is placed within section *Capricornua* Hochr., the remainder of which have scorpioid cymes but glabrous petals. The ovules and seeds of *D. rigida* bear a shallow marginal wing; according to Arènes' (1959) treatment of Malagasy Sterculiaceae, winged seeds would place the species within the tribe Helmiopsidae Arènes, rather than in Dombeyeae Benth. & Hook. Characters that would then place *D. rigida* within *Helmiopsis* rather than a related genus include a monadelphous androecium, with stamens borne opposite the sepals and staminodes opposite the petals, and glabrous locules (Dorr, 2001). (Stamen position was treated by Arènes as being a reliable character at the generic level, but actually is more variable within certain genera than usually recognized, and indeed appears to vary within *D. rigida* itself.) This placement may be regarded as controversial. *Dombeya rigida* (and *D. linearifolia*) would be anomalous in *Helmiopsis*, lacking a number of characters common within the genus, and most of the characters that are shared with species of *Helmiopsis* can also be seen in some other species of *Dombeya*, although glandular petals are otherwise atypical of the latter genus. *Dombeya* is an exceedingly variable genus, and the possibility that it is paraphyletic or polyphyletic relative to other Malagasy genera of Malvaceae s.l. cannot be discounted.

MORPHOLOGICAL CHARACTERS

VEGETATIVE CHARACTERS

All species of *Helmiopsis* are woody plants, usually reported to be trees or large shrubs; some reach to

20 m in height. Twig bark is grayish to dark reddish brown, shallowly ridged, with small pale lenticels; in all but one species, young twigs are at least sparsely lepidote or scaly. Leaves are alternate, simple, and stipulate; the stipules, where known, are small and inconspicuous, lepidote, and always rapidly caducous. Petioles are always lepidote. Shape and size of the leaf blade and relative length of the petiole are quite variable, as is the shape of the leaf apex. Section *Helmiopsis* has relatively narrow leaves, with length usually well exceeding breadth, and petioles that, except in one species, seldom exceed 1.5 cm long; section *Glandulipetalae* has leaves ranging from broadly ovate to orbicular, in one species the breadth well exceeding the length, and with petioles frequently 2 cm to several centimeters long. The leaf base ranges from rounded to rounded-truncate or shallowly cordate; the margins are usually entire to weakly undulate or weakly repand, but may be crenulate to crenate-serrate. Both leaf surfaces or at least the abaxial surface are lepidote in most species; one species has entirely glabrous leaves, while another has sparse stellate pubescence on the adaxial surface and typical scales abaxially. All but one species of section *Helmiopsis* have three or sometimes five basal veins, with the lateral veins weak and inconspicuous, so that venation is basically pinnate; species of section *Glandulipetalae* have five to seven well-developed palmate veins at the base. Most species can be differentiated solely by their leaf morphology.

INFLORESCENCE

Inflorescences are cymose or geminate; cymes may be well developed with elongated peduncles and several orders of branching (a character seen only in section *Glandulipetalae*) or small, few-flowered, and sometimes umbelliform. Inflorescences are normally lateral; only one species seems to produce genuinely terminal inflorescences, although several species may appear to have terminal inflorescences due to tight clustering of cymes at the tips of twigs. Bracts and bracteoles, where known, are small and rapidly caducous. Pedicels are angular, except in one species with subterete pedicels, and are articulated at the point of insertion of the bracteoles, which may be immediately beneath the bud or well below it. All parts of the inflorescence are lepidote.

CALYX

Sepals are more or less lanceolate, fused only at the base, and lepidote, and have a patch of glandular tissue on the inner surface near the base that varies in extent and visibility. This has been presumed to be

absent in some species, including all of those that have glandular petals; Barnett (1987) was the first to note both sepal and petal glandularity in the newly described *Helmiopsis sphaerocarpa*. In fact, in all species of *Helmiopsis*, very small relict patches of apparently glandular tissue remain within the basal-most portion of the calyx, where they are not readily observed. Sepals are sometimes reflexed in section *Glandulipetalae*, but generally not so far as to display the glandular tissue.

Similar small basal spots of glandular tissue were noted by Hochreutiner (1926) in a species of *Dombeya* sect. *Capricornua* (*D. urenoides* Hochr.). Specimens of other species of that section (including *D. borraginopsis* Hochr., *D. greveana* Baill., and probably *D. marivorahonensis* Arènes and *D. triumfettifolia* Bojer) have been observed to have tiny glandular patches within the basalmost fused portion of the calyx, although *D. rigida* and *D. linearifolia* do not. The character is also more widely distributed both in *Dombeya* subg. *Dombeya* (e.g., *D. cacuminum* Hochr.) and in subgenus *Xeropetalum*, including virtually all species of section *Decastemon* (pers. obs.; in prep.) as well as some species of section *Xeropetalum* (e.g., *D. rienanensis* Appleq. [Applequist, 2009]). However, some species in both subgenera lack sepal glands. Similar sepal glands might represent evidence of affinities between *Dombeya* subg. *Dombeya* and *Helmiopsis*; however, many distantly related genera of Malvaceae also bear nectary tissue on the sepals (Vogel, 2000).

COROLLA

Petals vary in size, caducousness, and in the presence or absence of small rounded, easily detached surface glands on the basal portion of the adaxial surface. They are generally obovate, occasionally obdeltoid or orbicular, whitish or pale-colored, and often flimsy in texture; they sometimes have a markedly asymmetrical apex and frequently seem to be caducous.

ANDROECIUM

The androecium varies in the depth of the fused basal corona, the number of stamens, and the relative length and shape of the staminodes, filaments, and anthers. Staminodes may be shorter or longer than fertile stamens, which are borne in five groups alternating with the staminodes; staminodes are longer than the stamens in section *Glandulipetalae* and one species of section *Helmiopsis*, *H. glaberrima* Arènes. Traditionally, *Helmiopsis* is described as having oppositisepalous stamens, as do many other plants,

and oppositipetalous staminodes; this is one of the features that is said to differentiate it from *Dombeya*, which, like a few other Malagasy genera of Malvaceae s.l., usually has oppositipetalous stamens and oppositisepalous staminodes (Arènes, 1959). However, this character proves to be more variable than generally believed. *Helmiopsis* specimens referable to section *Glandulipetalae* and one other species, *H. hily*, usually have more or less oppositisepalous staminodes, although some degree of apparent variation in stamen and staminode position can be seen even within individuals. Intermediate positions of these organs, not clearly opposite either petals or sepals, do occur.

OVARY AND FRUIT

The ovary is lepidote and 5-carpellate except in one species, *Helmiopsis hily*, which has three or occasionally four carpels; ovary lobing, style length and scaliness, and conformation of stigma branches are variable. All but one species of section *Helmiopsis* have relatively long, spreading to recurved branches, whereas all species of section *Glandulipetalae* have short, erect, tightly appressed lobes. The fruit is a loculicidal capsule, which varies in shape and color. According to Arènes (1959), one of the distinctions between *Helmiopsis* and *Helmiopsiella* Arènes is that the locules of the former are internally glabrous rather than pubescent. However, mature fruits of *Helmiopsis boivinii* (Baill.) Arènes (including the type of *H. inversa*, the type of the genus) have small white-pubescent patches on the basalmost portion of the septa and the central portion of the base of the fruit. Ovules and seeds of *Helmiopsis* s. str. usually bear an elongated apical wing, at least as long as the seed proper; one species, *H. sphaerocarpa*, has at most an inconspicuous ventral ridge. Seeds may number one or two per locule; if two, one is generally larger and better developed. Fruits and mature seeds of some taxa are not known.

TAXONOMIC TREATMENT

The major taxonomic issue in defining *Helmiopsis* is whether it shall be circumscribed so as to encompass *Dombeya rigida*, as proposed by Dorr (2001), and presumably its sister species *D. linearifolia*, or whether these species shall be excluded, following the traditional circumscription (sensu Arènes, 1959). Only the winged seed, often oppositisepalous stamens, and glandular petals supported placement within *Helmiopsis* rather than *Dombeya*. Winged ovules were taken to be the most critical character by Dorr (2001), but it is not clear that the curved, shallow marginal

wing of *D. rigida* is homologous with the narrow, prominently elongated apical wing of most *Helmiopsis* species (excluding *H. sphaerocarpa*). The seeds of *D. linearifolia* are not winged. If the petal glands were homologous to those in *Helmiopsis*, it would reflect specific affinities to section *Glandulipetalae*, with which *D. rigida* and *D. linearifolia* also share stamens that are shorter than the staminodes and normally 10 in number. One would therefore expect the latter species to possess some of the features that are otherwise common to all species of *Helmiopsis*, and presumably plesiomorphic within the genus. However, they in fact lack several such features, including lepidote pubescence on at least some organs, glandular tissue on the sepals, and rapidly caducous bracteoles (Table 1). Furthermore, the members of section *Glandulipetalae* usually have oppositipetalous stamens. *Dombeya rigida* and *D. linearifolia* also display characters that are seen in other *Dombeya* species but not in *Helmiopsis*, such as cymes with scorpioid branches. Thus, no matter where these species are placed, considerable morphological divergence from close relatives must be postulated. As noted, patterns of morphological variation within *Dombeya* are complex and difficult to interpret, and the monophyly of the genus is not proven. Pending the availability of molecular data that may address these issues (C. Skema, pers. comm.), it seems most conservative to leave *D. rigida* and *D. linearifolia* within *Dombeya* subsect. *Rigidae*. It is plausible that *Helmiopsis* may prove to be embedded within *Dombeya* as presently defined, although the status of *Helmiopsis* as a natural group worthy of recognition at some level is not in question, given the presence of several apparent morphological synapomorphies.

Arènes' (1956, 1959) infrageneric classification is modestly rearranged herein. The distinction between section *Glandulipetalae* and section *Helmiopsis* (both within subgenus *Helmiopsis*, according to Arènes) is easily made by vegetative as well as reproductive morphology, and recognition of these sections is maintained. *Helmiopsis hily*, the single species placed by Arènes within subgenus *Phelmiosis*, has for the most part typical features of section *Helmiopsis* and is here included within that section; the reduction in carpel number to usually three is certainly an autapomorphy and there is no reason to suppose that this species is sister to the remainder of the genus. No division of the genus at the subgeneric level is therefore recognized. In the absence of reproductive data, species are defined pragmatically by the recognition of unique suites of morphological characters. Nine species and one subspecies are recognized, of which one species and the subspecies are newly described.

Table 1. Morphological distinctions among *Helmiopsis* sect. *Glandulipetalae* (four species), *Helmiopsis* sect. *Helmiopsis* (five species), and *Dombeya* subsect. *Rigidae* (*Dombeya rigida* and *D. linearifolia*).

	<i>Helmiopsis</i> sect. <i>Glandulipetalae</i>	<i>Helmiopsis</i> sect. <i>Helmiopsis</i>	<i>Dombeya</i> subsect. <i>Rigidae</i>
Vegetative, inflorescence, and sepal pubescence	lepidote throughout	usually lepidote throughout; leaves of one species stellate adaxially	stellate throughout, or sometimes with scurfy scales on twigs
Inflorescence	dichotomously branching cymes or geminate	cymose, geminate or solitary, always small	cymes with scorpioid branches
Bracteoles	rapidly caducous	usually rapidly caducous; where sometimes persistent, not enveloping bud	often persistent in bud; relatively large and broad, convex, sometimes enclosing buds
Sepal glands	present in small, inconspicuous patches inside base	present, sometimes in large noticeable patches	absent
Petal glands	present	absent	present
Stamen position	+ opposite petals	+ opposite sepals, except in one species	+ opposite sepals
Androecial conformation	fertile stamens 10, shorter than staminodes	fertile stamens 15 to 30, longer than staminodes except in one species	fertile stamens 10, shorter than staminodes
Ovary pubescence	lepidote	lepidote	stellate
Seed morphology (where known)	bearing an elongated apical wing, or a narrow keel in one species	bearing an elongated apical wing	bearing a shallow wing around most of seed margin, or wingless

Helmiopsis H. Perrier, Bull. Soc. Bot. France 91: 230. 1944. TYPE: *Helmiopsis inversa* H. Perrier.

Trees or shrubs; twig bark grayish to dark reddish brown, shallowly ridged, with small pale lenticels; young twigs lepidote or occasionally glabrous. Leaves alternate, stipulate, petiolate, simple, variable in shape; stipules small, \pm lanceolate, lepidote, rapidly caducous; petiole lepidote or occasionally glabrous; leaf base rounded to shallowly cordate or rounded-truncate; margins entire to weakly undulate, weakly repand, crenulate, or crenate-serrate; at least the abaxial surface usually lepidote, occasionally glabrous or the adaxial surface sparsely stellate-pubescent. Inflorescences cymose, ranging from small and sometimes umbelliform to well developed with several orders of branching, or geminate, usually lateral, occasionally terminal or pseudoterminal; bracts where present small, rapidly caducous; all parts of inflorescences lepidote. Flowers actinomorphic, hermaphroditic, pedicellate; pedicels angular or occasionally subterete, articulated at the point of insertion of bracteoles; bracteoles 3, small, lanceolate to ovate, lepidote, rapidly caducous, inserted immediately below bud or well below bud on pedicel; sepals 5, free except at extreme base, lanceolate, lepidote, normally bearing at least small patches of glandular tissue on the adaxial surface near the base; petals 5, free, obovate to obdeltoid or orbicular, frequently caducous, in section *Glandulipetalae* bearing small

round glands on basal half of adaxial surface; androecium basally fused into a short corona; fertile stamens 10 to 30 (very rarely 5 in aberrant individuals), borne in 5 groups alternating with spatulate to oblong or oblong-obovate staminodes; stamens may be shorter than staminodes and \pm oppositipetalous or longer than staminodes and usually \pm oppositisepalous, with filaments of the latter group sometimes basally fused into fascicles; anthers linear to oblong; gynoecium (3- to)5-carpellate; ovary syncarpous, superior, lepidote, sometimes lobed; style lepidote basally or throughout; style lobes (3 to)5, short, erect, and clustered, or well developed and usually recurved to spreading. Fruit, where known, a loculicidal capsule, variably shaped, sometimes lobed; seeds 1 or 2 per locule, apically winged or occasionally unwinged.

Distribution and habitat. *Helmiopsis* comprises nine species, all endemic to Madagascar. The greatest diversity within the genus is at the northern tip of the island, but species of section *Helmiopsis* are native to northwestern and southwestern Madagascar. Habitats include forest, scrub, and coastal dunes; substrates include sand, limestone, alluvial soil, and basalt.

KEY TO SECTIONS OF *HELMIOPSIS* IN MADAGASCAR

- 1a. Leaves elliptical to ovate, lanceolate, or oblong; petioles relatively short, less than 15(–28) mm

long; inflorescences 1- to 5-flowered; petals not glandular; stamens 15 to 30 section *Helmiopsis*

- 1b. Leaves broadly ovate to orbicular or transversely elliptical; petioles usually over 15 mm, to several centimeters long; inflorescences variable; petals glandular; stamens 10 section *Glandulipetalae*

I. *Helmiopsis* sect. *Helmiopsis*.

Helmiopsis subg. *Phelmiosis* Arènes, Bull. Mus. Natl. Hist. Nat., sér. 2, 28: 415. 1956.

Trees to 10 m high or shrubs, sometimes large; twig bark grayish to dark reddish brown, shallowly ridged, with small pale lenticels; young twigs lepidote or glabrous. Leaves variable, lanceolate-oblong to elliptical, ovate, or broadly ovate, seldom very broad; petiole lepidote or glabrous; basal veins 3(5), inconspicuous; base rounded or shallowly cordate; apex rounded to acute, variably emarginate in some species; margins entire to weakly undulate; abaxial surface lepidote or glabrous; adaxial surface lepidote, glabrous, or sparsely pubescent with flat stellate hairs; stipules where known less than 1.5 mm, rapidly caducous. Inflorescences lateral, geminate or 3- to 4(to 5)-flowered cymes, sometimes umbelliform, or 1-flowered, often clustered near twig apices; occasional bracts very small, rapidly caducous; bracteoles rapidly caducous, sometimes ovate and persisting in smaller buds; pedicels angular to subterete, articulated; inflorescences lepidote throughout. Sepals narrowly lanceolate, lepidote, with sometimes conspicuous patches of glandular tissue on basal portion of adaxial surface; petals obovate to obdeltoid or orbicular, not glandular; fused base of androecium coroniform, sometimes almost absent; fertile stamens 15 to 30, usually \pm oppositisepalous,

in one species frequently oppositipetalous; staminodes spatulate to oblong or oblong-obovate, shorter than longest stamens; filaments free to corona or basally fused into fascicles; anthers linear to oblong; gynoecium (3- to)5-carpellate; ovary lepidote, sometimes lobed; style lepidote basally or throughout; style lobes well developed, recurved to spreading or erect and appressed in one species. Fruit where known, a capsule, variable in shape, sometimes lobed; seeds where known, 1 or 2 per locule, apically winged.

Distribution. *Helmiopsis* sect. *Helmiopsis* ranges from the northern end of Madagascar to the arid southwest (Fig. 1).

Discussion. *Helmiopsis glaberrima*, a rare northern species for which only one specimen is known, complicates the distinction between section *Helmiopsis* and section *Glandulipetalae*. Its affinities are clearly with section *Helmiopsis*, as it has narrow leaves, 15 oppositisepalous stamens, small inflorescences, well-developed sepal gland patches, and long style lobes. However, it displays a few characters (normally five basal leaf veins, relatively long petioles, fertile stamens shorter than the staminodes, and erect, appressed style lobes) that are otherwise typical of section *Glandulipetalae*. The hypothesis tentatively favored by this author is that *H. glaberrima* is sister to the remainder of section *Helmiopsis*, and that the few characters shared with section *Glandulipetalae* are plesiomorphic within *Helmiopsis*. However, an alternate hypothesis is that section *Helmiopsis* is paraphyletic, with *H. glaberrima* actually being the sister taxon of section *Glandulipetalae*.

KEY TO THE SPECIES OF *HELMIOPSIS* SECT. *HELMIOPSIS* IN MADAGASCAR

- 1a. Leaves glabrous; stamens shorter than staminodes; style branches erect 3. *H. glaberrima*
 1b. Leaves lepidote at least abaxially; stamens longer than staminodes; style branches spreading or recurved.
 2a. Leaves narrowly lanceolate to lanceolate, mostly less than 2 cm broad; adaxial surface glabrous, abaxial surface densely lepidote, pale or silvery green; stamens 15; ovary and fruit 3-carpellate, deeply 3-lobed 4. *H. hily*
 2b. Leaves variable in shape, not narrowly lanceolate, often over 2 cm broad; adaxial surface glabrous or sparsely stellate or lepidote, abaxial surface variably lepidote; stamens (15 to)20 to 30; ovary and fruit 5-carpellate, not conspicuously lobed.
 3a. Leaves narrowly ovate to lanceolate, adaxial surface weakly pubescent with flat stellate hairs; sepals 11–13 mm long; petals 14–17 mm long, pale yellow with pale pink highlights 2. *H. calcicola*
 3b. Leaves variable in shape, adaxial surface lepidote to glabrous; sepals less than 11 mm long; petals less than 13 mm long, sometimes white.
 4a. Leaves ovate to elliptical, broadly ovate, or lanceolate; pedicels (6–)8–16(–19) mm long, not much elongated in fruit; petals (6–)10–13 mm long, obovate to obdeltoid; stamens (15 to)20 to 25; staminodes spatulate, 2.8–4(–5) mm long 1. *H. boivinii*
 4b. Leaves oblong-elliptical to elliptical or lanceolate, rarely ovate; pedicels 3–6 mm long, in fruit up to 10 mm; petals 8.2–9.3 mm long, suborbicular; stamens 30; staminodes oblong-obovate, 2.7–3.1 mm long 5. *H. polyandra*

1. *Helmiopsis boivinii* (Baill.) Arènes, as “*Boivini*,” Bull. Mus. Natl. Hist. Nat., sér. 2, 28: 418. 1956. Basionym: *Trochetia boivinii* Baill., as “*Boivini*,” *Adansonia* 10: 109–110. 1871. *Dombeya boivinii*

(Baill.) Baill., as “*Boivini*,” Bull. Mens. Soc. Linn. Paris 1: 496. 1885. TYPE: Madagascar. Mahajanga: Ambongo, 14 Feb. 1841 (fl.), A. Pervillé 642 (holotype, P!; isotypes, G not seen, P!).

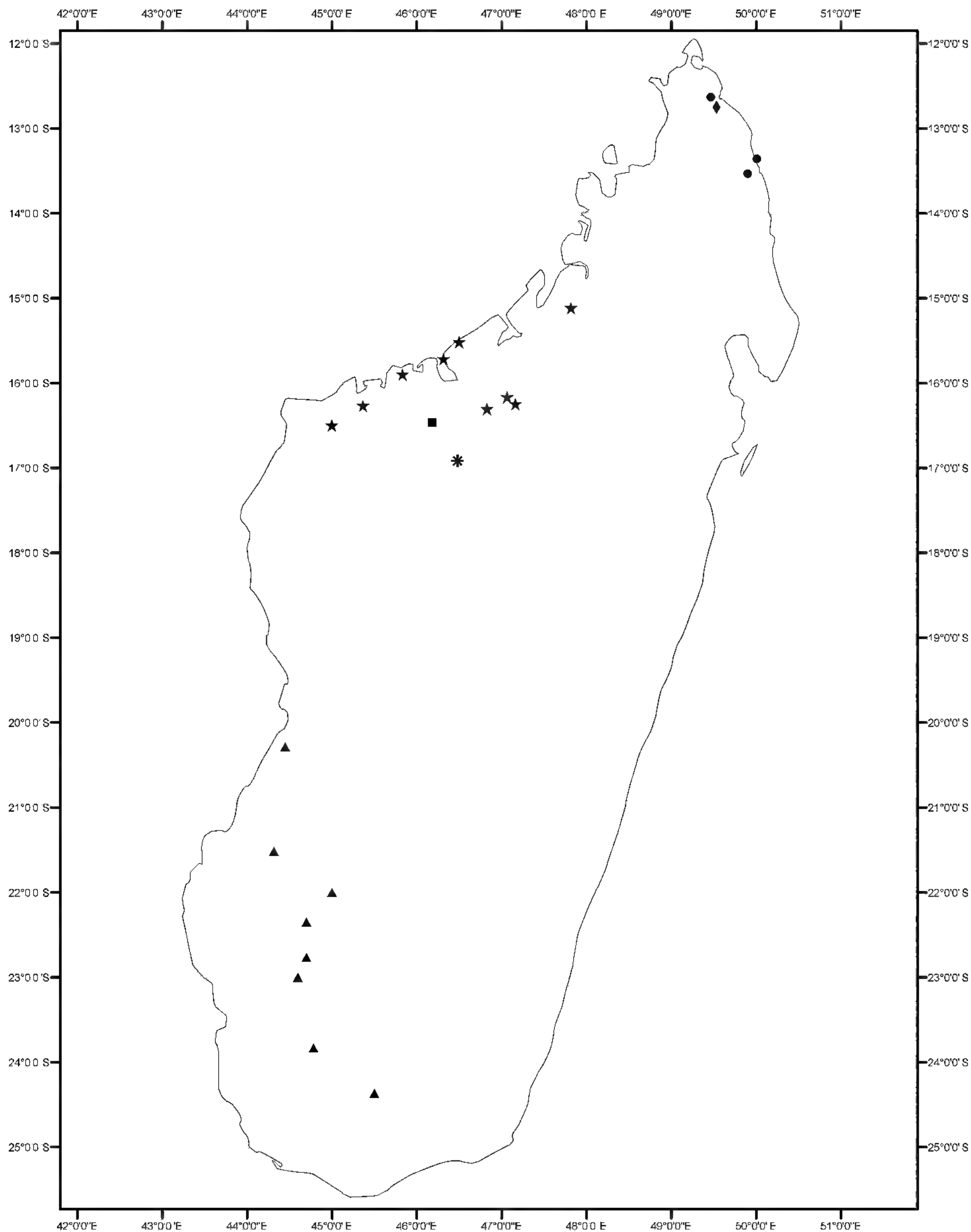

Figure 1. Approximate distribution of species of *Helmiopsis* sect. *Helmiopsis* (★ – *H. boivinii*; * – *H. calcicola*; ◆ – *H. glaberrima*; ▲ – *H. hily* subsp. *hily*; ■ – *H. hily* subsp. *boinensis*; ● – *H. polyandra*).

Helmiopsis inversa H. Perrier, Bull. Soc. Bot. France 91: 230. 1944, syn. nov. TYPE: Madagascar. Mahajanga: Ampasimarina [15°31'S, 046°30'E] au N de Majunga [Mahajanga], 27 May [1932?] (fr.), *H. Perrier de la Bâthie 17986* (lectotype, designated here, P!; isotypes, P!, TAN!).

Shrub to 4 m high or tree to 10 m high, 20 cm diam.; bark grayish, sometimes splotched, with pink-orange slash; twig bark grayish, shallowly ridged, with small pale lenticels; young twigs lepidote. Leaves ovate to elliptical, broadly ovate, or lanceolate, (2.5–) 3.6–7.3(–8.4) × (1.4–)1.7–3.8(–4.5) cm, frequently

caducous; petiole 7–15(–18) mm, densely lepidote; basal veins 3(to 5), the lateral weak; base rounded to very shallowly cordate; apex rounded or acute with rounded tip, occasionally slightly emarginate; margins entire to slightly undulate; both surfaces lepidote in young leaves, sparsely so in older leaves, the adaxial surface sometimes becoming glabrous; scales of leaves and petioles variable in size and shape, occasionally fimbriate; stipules less than 1 mm, lepidote, rapidly caducous and very rarely present. Inflorescences up to 4(to 5)-flowered cymes, often umbelliform, or gemi-

nate or flowers occasionally single, borne laterally, mostly near twig apices; usually only 1 or 2 flowers per inflorescence maturing; bracts less than 1.2 mm, deltoid, rapidly caducous; pedicels \pm angular, articulated, (6–)8–16(–19) mm, becoming woody in fruit; bracteoles 3, borne near base of flower, deltoid, caducous, ca. 1 mm; inflorescences lepidote throughout. Sepals narrowly lanceolate, (6.5–)8.5–11 mm, pale green to whitish, lepidote, the adaxial surface basally glandular; petals white, (6–)10–13 \times (4–)6–8.2 mm, obovate to obdeltoid; androecial corona 0.5–1 mm; fertile stamens (15 to)20 to 25, in groups of (3 to)4 to 5, opposite sepals, white; filaments 2.5–4.8 mm, often free to corona, occasionally fused at the base into distinct fascicles; anthers linear-oblong, 2.3–3.5(–4.1) mm; staminodes spatulate, 2.8–4(–5) mm, shorter than longest stamens; gynoecium 5-carpellate; ovary lepidote, white; style lepidote mostly on lower portion, 3–5 mm; style lobes erect and spreading or rarely recurved, (0.6–)1–2.3 mm. Fruit a woody capsule, (11–)13–19 mm, ovoid to cylindrical, sometimes with apparently swollen base or constriction above the base, sometimes 5-ribbed or shallowly lobed, lepidote, pale brown to blackish brown at maturity; central base of capsule inside and basalmost part of septa often white-pubescent, hairs sometimes fused at base into flat clusters; seeds (2.5–)3.4–4.5 mm with often asymmetrical 5.2–8.5 mm apical wing, 2 per locule, only 1 well developed.

Distribution, phenology, and habitat. Most collections are from a limited area of northwestern Madagascar, including localities around Mahajanga, the Ankarafantsika reserve, and the Ambongo region (Fig. 1); only a few clearly distinct populations have been collected. The habitat is on sand, including coastal dunes, in scrub or forest; reported altitudes range up to 200 m. Existing flowering collections are from November to February, with buds seen in May; fruiting may occur at almost any time of year, with developing or undehisced fruits collected in February, March, June, August, and November.

IUCN Red List category. Provisional IUCN Red List category (IUCN, 2001) is noted as Least Concern (LC).

Common names and uses. Mainaty (*Réserves Naturelles* 2067, 2568, 2832, 2944; *Service Forestier* 12666); Maintinaty (*Service Forestier* 14785); Amonty (*Service Forestier* 50); Selivato (*Service Forestier* 15782). The wood has been used in construction (*Service Forestier* 12666).

Orthography. Under Article 60.11 of the ICBN (McNeill et al., 2006), the original spelling (“*boivini*”) of the epithet of *Helmiopsis boivinii* is treated as an

error to be corrected, as Arènes (1959) did in his *Flore de Madagascar* treatment.

Discussion. There is no qualitative distinction between *Helmiopsis boivinii* and *H. inversa*, which are native to the same region of northwestern Madagascar. The more frequently collected populations that have been called *H. inversa* display considerable variation in such characters as leaf size and shape, leaf pubescence and scale morphology, and fruit shape. However, these characters do not vary in concert, nor are they consistently correlated with locality of origin. In 1963, Capuron determined specimens of *H. inversa* at P as *H. boivinii*, indicating that he thought the two taxa should be combined, but does not appear to have published this treatment. *Helmiopsis boivinii* and the invalidly published *H. inversa* var. *arenicola* H. Perrier were each described based on single specimens from Ambongo, an area where classic *H. inversa* has not been collected, and are distinguished by their somewhat larger leaves and smaller flowers. However, the increased leaf size and reduced petal size seen at Ambongo do not significantly exceed the extremes from collections at other repeatedly collected localities. Moreover, the types of these two putative taxa appear to be in early rather than full flower, and it is possible that the availability only of incompletely developed flowers reduced the apparent petal size. Therefore, there seems to be inadequate reason to formally distinguish the Ambongo population from other populations in the region at any taxonomic level.

Although *Helmiopsis inversa* is the type species for the genus, the epithet of *H. boivinii* predates its publication and thus has precedence when the two are combined. Perrier de la Bâthie (1944: 231) listed two specimens, *Perrier de la Bâthie* 17986 and 13858, as “[t]ypes du genre et de l’espèce [*H. inversa*].” The latter number seems to be a misprint, as the only similar Perrier specimen at P, from the same locality (Ampasimana au N de Majunga) and date (July 1921), is clearly numbered 13838. Arènes (1956b, 1959) listed *Perrier de la Bâthie* 13838 and 17986 as types in view of this fact. It appears that neither specimen has ever been selected to serve as a single lectotype. *Perrier de la Bâthie* 17986 is herein chosen because it is in better condition, with buds as well as old fruit, and three duplicates exist; this choice also avoids any argument over whether the specimen whose number was misstated can be considered original material.

Representative specimens examined. MADAGASCAR. **Mahajanga:** several km N of Majunga [Mahajanga; 15°43’S, 046°19’E], vic. Zaha Motel, *Barnett et al.* 478 (MO, TAN); Namakia–Dunes de Boeny Ampasy, S/P. de Mitsinjo [15°54’S, 045°50’E], *Debray* 1442 (P); dunes, Ampasimarina [15°31’S, 046°30’E] au N de Majunga

[Mahajanga], *Perrier de la Bâthie* 13838 (P); RN4, Réserve forestière d'Ampijoroa, Jardin Botanique B, à l'E du Lac Ravelobe, 16°18'19"S, 046°49'38"E, *Randrianaivo et al.* 399 (MO); Ankarafantsika, canton Tsaramandroso, distr. Ambato-Boeni [RN7, 16°10'S, 047°04'E], *Réserves Naturelles* 2067 (MO, P, TAN); 7è Réserve [Ankarafantsika], Ligne Bépilo, *Service Forestier* 50 (P); W du village de Bevazaha [16°14'50"S, 047°09'50"E], canton de Tsaramandroso, distr. d'Ambato-Boeni, *Service Forestier* 12666 (P); forêt Analalava, Maintirano, *Service Forestier* 14785 (MO); forêt tout près de Maherivaratra, village le plus proche Ambodibonara, canton Ankerika [14°57'S, 047°52'E], distr. Antsohihy, *Service Forestier* 15782 (P, TAN); près d'Ampasimariny [15°31'S, 046°30'E], au NE de Majunga, *Service Forestier* 24317 (MO, P).

2. *Helmiopsis calcicola* Arènes, Mém. Inst. Sci. Madagascar, Sér. B, Biol. Vég. 7: 55–56. 1956. TYPE: Madagascar. Antsiranana: forêt tropophile sur rocailles calcaires, Kama-Kama, sur le plateau d'Ankara (Boina) [16°55'S, 46°29'E], v. 100 m alt., Jan. 1900 (fl.), *Perrier de la Bâthie* 1018 (holotype, P!; isotypes, P [2]!).

Shrub, 2–3 m high, with hard wood; twig bark grayish, shallowly ridged, with small pale lenticels; young twigs yellowish, lepidote. Leaves narrowly ovate to lanceolate, (3.5–)6–8.5 × (1.3–)2.3–3.5 cm, caducous, membranous; petiole 4–12 mm, densely lepidote; basal veins 3, the lateral weak; base rounded; apex acute; margins entire; abaxial surface lepidote, adaxial surface sparsely pubescent with flat stellate hairs, especially along midrib; stipules ca. 1 mm, deltoid, lepidote, usually caducous. Inflorescences few-flowered, axillary, probably mostly geminate with peduncle less than 2 mm; pedicels ± angular, articulated, ca. 10–16 mm; bracteoles inserted below base of flower; peduncles and pedicels lepidote. Sepals narrowly lanceolate, 11–13.2 mm, lepidote, the basal half of the adaxial surface glandular and reddish; petals pale yellow with pale pink highlights, 14–17 × 9–11 mm, obovate with asymmetrical apex; androecial corona 0.6–1 mm; fertile stamens ca. 30, in groups of (5 to)6(to 7), opposite sepals; filaments red, 2.5–4.8 mm; anthers yellow, linear-oblong, 2.3–3.5(–4.1) mm; staminodes reddish, spatulate to oblong, 3.5–4.8 mm; gynoecium 5-carpellate; ovary lepidote, 5-ribbed; style pale yellow, lepidote throughout, 4–4.5 mm; style lobes recurved, 3–4 mm. Fruit unknown.

Distribution, phenology, and habitat. The only known collection is from the Ankara region of northwestern Madagascar (Fig. 1); the species was flowering in January 1900.

IUCN Red List category. Provisional IUCN Red List category (2001) is noted as Data Deficient (DD). This area has been inadequately collected, so a lack of collections is not necessarily evidence of rarity.

However, the fact that the region has suffered considerable habitat degradation is cause for concern.

Discussion. This is the only species of *Helmiopsis* that has more or less stellate pubescence in addition to lepidote scales; the stellate pubescence is sparse and confined to the adaxial leaf surface. Arènes (1956) based this species on *H. inversa* var. *calcicola* H. Perrier (Bull. Soc. Bot. France 91: 230. 1944), which was not validly published, as the description was given only in French, with no Latin diagnosis, which the ICBN required for taxa published after 1935 (Art. 36.1; McNeill et al., 2006). Arènes' name was accompanied by a full Latin description and so was validly published.

3. *Helmiopsis glaberrima* Arènes, Bull. Mus. Natl. Hist. Nat., sér. 2, 28: 417. 1956. TYPE: Madagascar. Antsiranana: Analamerana, Diégo-Suarez [12°45'S, 49°32'E], 16 Mar. 1954 (fl.), *Service Forestier* 9423 (holotype, P!; isotypes, MO!, P not seen).

Woody plant; twigs dark reddish brown, shallowly ridged, glabrous, with pale tan elliptical lenticels. Leaves lanceolate-oblong, 4–7.3 × 1.4–2.5 cm; petiole (4–)13–28 mm, glabrous, those at ends of twigs much shorter; basal veins 5, the lateral ones weak; base shallowly cordate; apex rounded-acute; margins entire; both surfaces glabrous; stipules caducous. Inflorescences geminate or 3-flowered cymes, lateral and pseudoterminal, clustered at twig ends; peduncle 11–17 mm, dark reddish brown, woody, sparsely lepidote; pedicels articulated, nearly terete, lepidote, ca. 6.5–8 mm; bracteoles inserted well below flower. Sepals narrowly lanceolate, 8.2–9 mm, lepidote, the basal half of the adaxial surface glandular; petals 12–14 × 9–10 mm, broadly obovate with clawed base; androecial corona 1.5–1.9 mm; fertile stamens ca. 15, in groups of (2 to)3(to 4), oppositisepalous; filaments 0.5–1 mm, fused into fascicles; anthers linear, 2.5–3.1 mm; staminodes spatulate, 6.5–7.5 mm; gynoecium 5-carpellate; ovary deeply 5-lobed, lepidote; style lepidote only at base, 4.5–5.1 mm; style lobes erect and closely appressed, 1.2–1.4(–2) mm; ovules elongated, apparently apically winged. Fruit unknown.

Distribution, phenology, and habitat. The only known collection is from the extreme north of Madagascar (Fig. 1); it was flowering in March.

IUCN Red List category. Provisional IUCN Red List category (2001) is noted as Vulnerable (VU D2). Only a single location is known, from the Analamera Special Reserve, and the area of occupancy is likely to be very small. Several remaining patches of

northern forest are relatively accessible and have been repeatedly collected; multiple specimens of more than one species of *Helmiopsis* sect. *Glandulipetalae* have been collected from certain areas. Thus, the lack of additional collections of this species suggests that it is indeed relatively rare and of limited distribution.

Discussion. *Helmiopsis glaberrima* is the only species of section *Helmiopsis* in which the staminodes are longer than the fertile stamens, as in section *Glandulipetalae*. It is also the only species of section *Helmiopsis* in which the style lobes are erect and closely appressed, though much longer than those in section *Glandulipetalae*, and the only one with petioles mostly more than 1.5 cm long and leaves mostly 5-veined at the base. In addition, it is easily distinguished from the remainder of section *Helmiopsis* by its completely glabrous leaves.

4. *Helmiopsis hily* Arènes, Bull. Mus. Natl. Hist. Nat., sér. 2, 28: 415. 1956. TYPE: Madagascar. Toliara: Betsipotika, Analaiava, Morondava [20°17'S, 044°27'E], 5 Apr. 1953 (fl.), *Service Forestier* 7226 (holotype, P!; isotype, TEF not seen).

Tree to 10 m high (to 20 m high and 0.5 m diam. in subspecies *boinensis*), or occasionally large shrub to 6 m high; twig bark dark grayish brown, shallowly ridged with small rounded pale lenticels; young twigs ferruginous, densely lepidote. Leaves borne directly on long twigs or singly or clustered on short shoots, narrowly lanceolate to lanceolate, (2.6–)3–7.3(–7.7) cm × (7–)9–16(–21) mm; petiole (1.5–)5–12(–13.5) mm, densely lepidote; basal veins 3, the lateral weak; base rounded; apex acute with rounded tip, occasionally rounded or emarginate; margins entire, often slightly irregular; adaxial surface glabrous, abaxial surface densely lepidote, pale or silvery green, usually with scattered tiny brown spots due to pigmentation of some large scales; midrib conspicuous, secondary venation pinnate, weak; stipules less than 1 mm, deltoid, lepidote, immediately caducous and very rarely present. Inflorescences lateral, geminate or occasionally a 3-flowered cyme or flowers solitary; peduncle (1–)2–11 mm; pedicels angular, articulated near bud, (4–)7–16 mm; bracteoles rapidly caducous; peduncles and pedicels lepidote; only 1 flower or all 2 to 3 flowers maturing to fruit. Sepals narrowly lanceolate, 7–9.2(–10) mm, lepidote, base of adaxial surface glandular-pubescent; petals creamy or yellow, (6.5–)8.5–13.5(–15) × (4.5–)5–7.5 mm, obovate, caducous; androecial corona 1.2–2 mm; fertile stamens normally 15; filaments 2–4.5(–5) mm; anthers linear, 2.1–3.8(–4.5) mm, often but not always clearly

oppositipetalous; staminodes spatulate, 2.5–3.2(–4) mm, oppositisepalous or occasionally tending toward oppositipetalous; gynoecium 3(to 4)-carpellate; ovary lepidote, 3(to 4)-lobed; style lepidote for entire length, (3.2–)4–5.8(–6.8) mm; style lobes strongly recurved, 2–3 mm. Fruit a 3-valved, lepidote capsule, irregularly elliptical to broadly oblong-elliptical or ovate-elliptical, deeply 3-lobed, (7.5–)8–15.6 mm; seeds (where known) 1 per locule, ca. 3.6–3.8 mm, irregularly elliptical with a flattened ventral surface, with a tapering apical wing ca. 4.2–5.1 mm.

Distribution. *Helmiopsis hily* is native to forests in the arid southwestern portion of Madagascar and (subspecies *boinensis*) the northwestern Boina region.

IUCN Red List category. Each subspecies is assessed separately, below.

Common names. Hily (*Service Forestier* 7226, 9819); Pisopisonala (*Service Forestier* 3398, 4984); Andriambolafoty (*Service Forestier* 14294); Menahy (*Service Forestier* 15794).

Discussion. Almost all flowers, and all maturing fruits seen, are 3-carpellate; the presence of four ovary lobes and style branches (as reported by Arènes, 1959) appears to be an abnormal condition. Arènes (1956b, 1959) placed this species alone within *Helmiopsis* subg. *Phelmiosis* due to its reduced carpel number. This treatment is unwarranted, as the reduction in carpel number seems very likely to be not a plesiomorphic character within the genus, but an autapomorphy, which has no relevance to the question of relationships to other species; *H. hily* otherwise has for the most part typical features of section *Helmiopsis*.

KEY TO THE SUBSPECIES OF *HELMIOPSIS HILY* IN MADAGASCAR

- 1a. Tree to 10 m high or large shrub; leaves (7–)9–16(–18) mm broad, mostly borne directly on twigs or clustered on short shoots; often only one flower per inflorescence maturing; pedicels (4–)7–10(–12) mm long; capsule (7.5–)8–10.6 mm long; native to southwestern Madagascar 4a. subspecies *hily*
- 1b. Tree to 20 m high; leaves to at least 21 mm broad, often borne singly on short shoots ca. 1 cm long; often all flowers (2 to 3) of inflorescence maturing; pedicels in fruit to 11–16 mm long; capsule 12–15.6 mm long; native to northwestern Madagascar 4b. subspecies *boinensis*

4a. *Helmiopsis hily* Arènes subsp. ***hily***.

Tree to 10 m high, or occasionally shrub to 6 m high. Leaves mostly borne directly on long twigs or clustered on short shoots, narrowly lanceolate to lanceolate, (2.6–)3–7.3(–7.7) cm × (7–)9–16(–18) mm; petiole (1.5–)5–12(–13.5) mm. Often only one flower per inflorescence maturing; peduncles (1–)3–

6(–11) mm; pedicels 4(–)7–10(–12) mm. Sepals narrowly lanceolate, 7–9.2(–10) mm, lepidote, base of adaxial surface glandular-pubescent; petals creamy or yellow, (6.5–)8.5–13.5(–15) × (4.5–)5–7.5 mm, obovate, caducous; androecial corona 1.2–2 mm; fertile stamens normally 15; filaments 2–4.5(–5) mm; anthers linear, 2.1–3.8(–4.5) mm, often but not always clearly oppositipetalous; staminodes spatulate, 2.5–3.2(–4) mm, oppositisepalous or occasionally tending toward oppositipetalous; gynoecium 3(to 4)-carpellate; ovary lepidote, 3(to 4)-lobed; style lepidote for entire length, (3.2–)4–5.8(–6.8) mm; style lobes strongly recurved, 2–3 mm. Fruit elliptical to oblong, (7.5–)8–10.6 mm, deeply 3-lobed; seeds 1 per locule, ca. 3.6–3.8 mm, irregularly elliptical with a flattened ventral surface, with a tapering apical wing ca. 4.2–5.1 mm.

Distribution, phenology, and habitat. *Helmiopsis hily* subsp. *hily* is native to southwestern Madagascar (Fig. 1). One collection was noted to be on sand at 600–850 m altitude. Flowering usually occurs from January to March (with one specimen flowering in October), as is typical in the arid southwest; immature fruit has been collected in March, and nearly mature fruit in May.

IUCN Red List category. Provisional IUCN Red List category (2001) is noted as Least Concern (LC).

Specimens examined. MADAGASCAR. **Toliara:** forêt de Zombitsy [22°46'S, 044°42'E], forêt de l'Isalo, *Humbert et al.* 29604 (MO, P); forêt près de l'Isahaina, entre Sakaraha et Beroroha, *Service Forestier* 527 (MO, P [2]); Onidranovory, Tuléar, *Service Forestier* 3398 (P, TAN); Hazoroa, Sakaraha [23°00'S, 044°36'E], *Service Forestier* 4984 (P, TAN); Troboampamaky, Beharona, Manja [21°31'S, 044°19'E], *Service Forestier* 9819 (MO, P); forêt de Zombitsy [22°46'S, 044°42'E], *Service Forestier* 11908 (P [3]); Zombitsy [22°46'S, 044°42'E], *Service Forestier* 14294 (P, TAN); Betsako, Ankazoabo [22°21'S, 044°42'E], *Service Forestier* 15794 (P); haut bassin de la Sakoa (rt. Betioky–Bekily), *Service Forestier* 20704ter (P); forêt d'Analamamatahitse (Analamatahotra) entre Bekily et la rte. Beraketa–Antanimora, *Service Forestier* 22531 (MO [2], P).

4b. *Helmiopsis hily* Arènes subsp. *boinensis* Appleq., subsp. nov. TYPE: Madagascar. Mahajanga: forêt de Bekapika sur le plateau d'Antanimena (Boina) [16°28'S, 046°11'E], 12–14 Nov. 1957 (fr.), *Service Forestier* 18423 (holotype, P!). Figure 2.

Haec subspecies a *Helmiopse hily* Arènes subsp. *hily* statura majore, foliis leviter latioribus saepe singulatim ad ramunculos breves portatis, inflorescentiis leviter majoribus atque fructibus majoribus differt.

Tree to 20 m high; many leaves borne singly on short shoots ca. 1 cm long; leaves lanceolate, 3.8–6.4 cm × 12–21 mm; petioles 7–13.5 mm. Usually

both (or all three) fruits per inflorescence maturing; at maturity peduncles 2–11 mm, pedicels 11–16 mm. Flowers not known. Fruit broadly oblong-elliptical to ovate-elliptical, 12–15.6 mm; seeds not known.

Distribution, phenology, and habitat. The single known collection is from the northwestern Boina region of Madagascar (Fig. 1); mature fruits, with seeds already dispersed, were collected in November.

IUCN Red List category. Provisional IUCN Red List category (2001) is noted as Data Deficient (DD).

Discussion. *Helmiopsis hily* subsp. *boinensis* can be distinguished from *H. hily* subsp. *hily* by its larger size (trees to at least 20 m), slightly broader leaves frequently borne singly on short shoots, larger inflorescences, and larger fruits. However, it resembles subspecies *hily* in other morphological characters; thus, lacking information on floral morphology or variation in vegetative morphology, the two are most conservatively treated as subspecies of a single species. A significant group of endemic species are confined to the area of northwestern Madagascar that includes the Boina region, e.g., *H. calcicola*, *Dombeya ankarafantsikae* Arènes and *D. boeniensis* Arènes (Arènes, 1958), *Perrierodendron boinense* (H. Perrier) Cavaco (Lowry et al., 2000), *Combretum boinensis* Jongkind (Jongkind, 1995), and *Dalbergia davidii* Bosser & R. Rabev. (Bosses & Rabevohitra, 1996), to name only a few. It would therefore be worth investigating the possibility that this disjunct and distinctive population actually represents another locally endemic species.

5. *Helmiopsis polyandra* Appleq., sp. nov. TYPE: Madagascar. Prov. Antsiranana: forêt d'Analafiana, au N de la basse Manambery (au SW de Vohémar [Iharana, 13°21'30"S, 050°00'30"E]), 11 Mar. 1967 (fl.), *Service Forestier* 27532 (holotype, P!; isotype, MO!). Figure 3.

Species nova quae a *Helmiopse boivini* (Baill.) Arènes foliis infra pallidis, pedicellis brevioribus, bracteolis longioribus tarde delapsis, petalis minus quam 10 mm longis suborbicularibus, staminibus ca. 30 atque staminodiis oblongo-obovatis 2.7–3.1 mm longis differt.

Tree to 8 m high; twig bark reddish brown, shallowly ridged, with pale lenticels; young twigs pale, lepidote. Leaves oblong-elliptical to elliptical, lanceolate, or rarely ovate, (2.2–)3.2–6.5(–9.5) × (1.1–)1.4–2.5(–3.4) cm; petiole 4–10(–13) mm, densely lepidote; basal veins 3(to 5), the lateral weak; base rounded; apex rounded-acute or emarginate; margins entire to weakly undulate; abaxial surface lepidote, adaxial surface at maturity sparsely lepidote or glabrous, sometimes bearing few tiny unbranched hairs of crystalline appearance, distinctly different

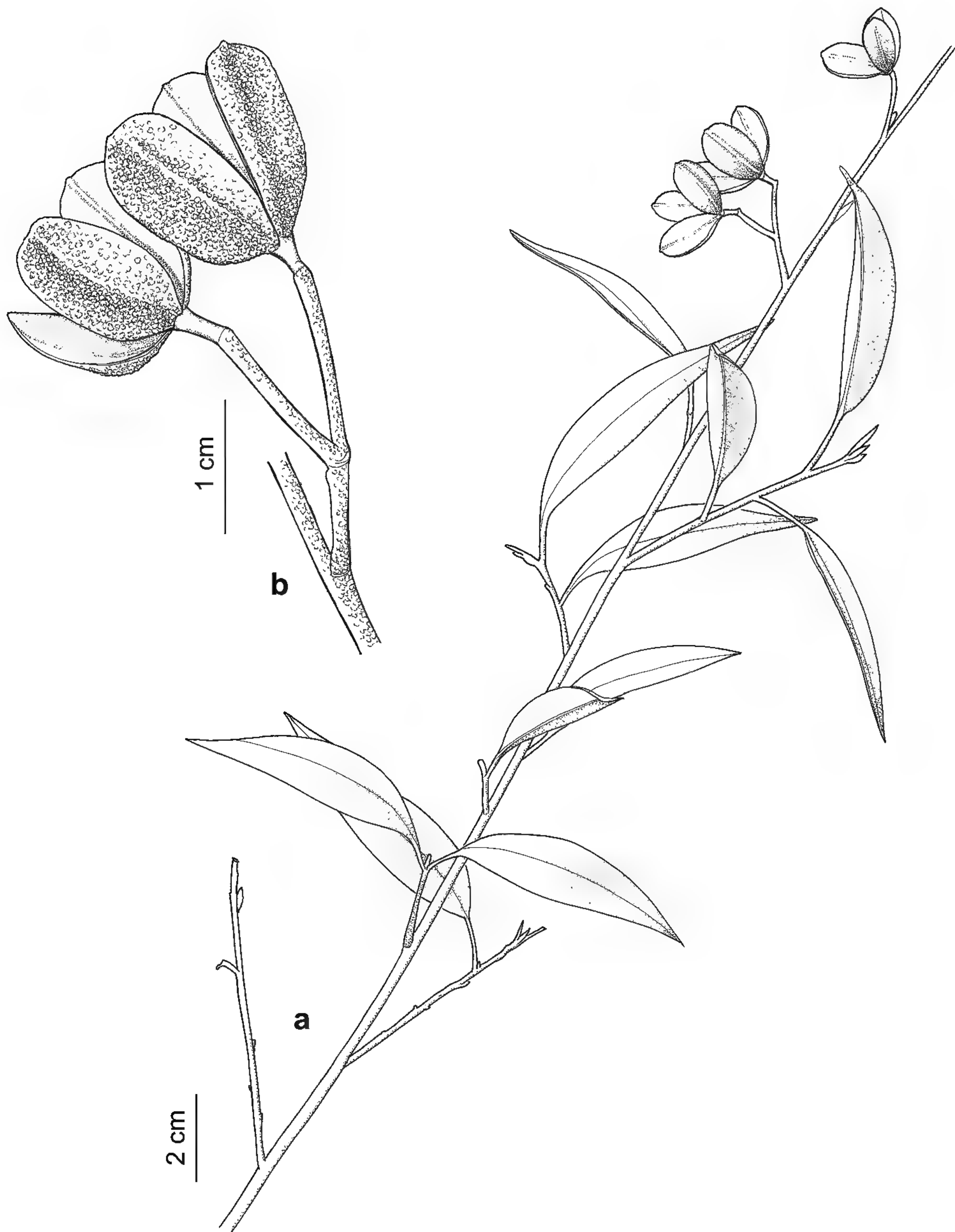

Figure 2. *Helmiopsis hily* Arènes subsp. *boinensis* Appleq. —A. Fruiting branch. —B. Old fruit. Based on the type, *Service Forestier* 18423.

from abaxial surface in color, usually with visible venation; stipules ca. 1.2–1.5 mm, lanceolate, lepidote, caducous and rarely present. Inflorescences geminate or 3- to 4-flowered cymes or flowers solitary, axillary; peduncles 2–6.5 mm; pedicels \pm angular, articulated, 3–6 mm, in fruit woody to 10 mm; bracts few, ca. 2.6–3.5 mm, caducous; bracteoles inserted slightly beneath bud, ovate, 1.3–1.7(–2.4) mm, caducous but often persisting on smaller buds; inflorescences lepidote throughout. Sepals narrowly

lanceolate, 7.5–8.2 mm, lepidote, the basal portion of the adaxial surface glandular; petals 8.2–9.3 \times 7.5–8.5 mm, suborbicular; androecial corona virtually absent; fertile stamens ca. 30, in groups of 6, oppositisealous; filaments 2–3.5 mm; anthers oblong, 2.3–3.1 mm; staminodes oblong-obovate, 2.7–3.1 mm; gynoecium 5-carpellate; ovary lepidote; style pale yellow, lepidote throughout, ca. 3 mm; style lobes erect with recurved apices, ca. 2.4–2.5 mm; ovule shortly winged. Mature capsule ca. 20 mm, roughly

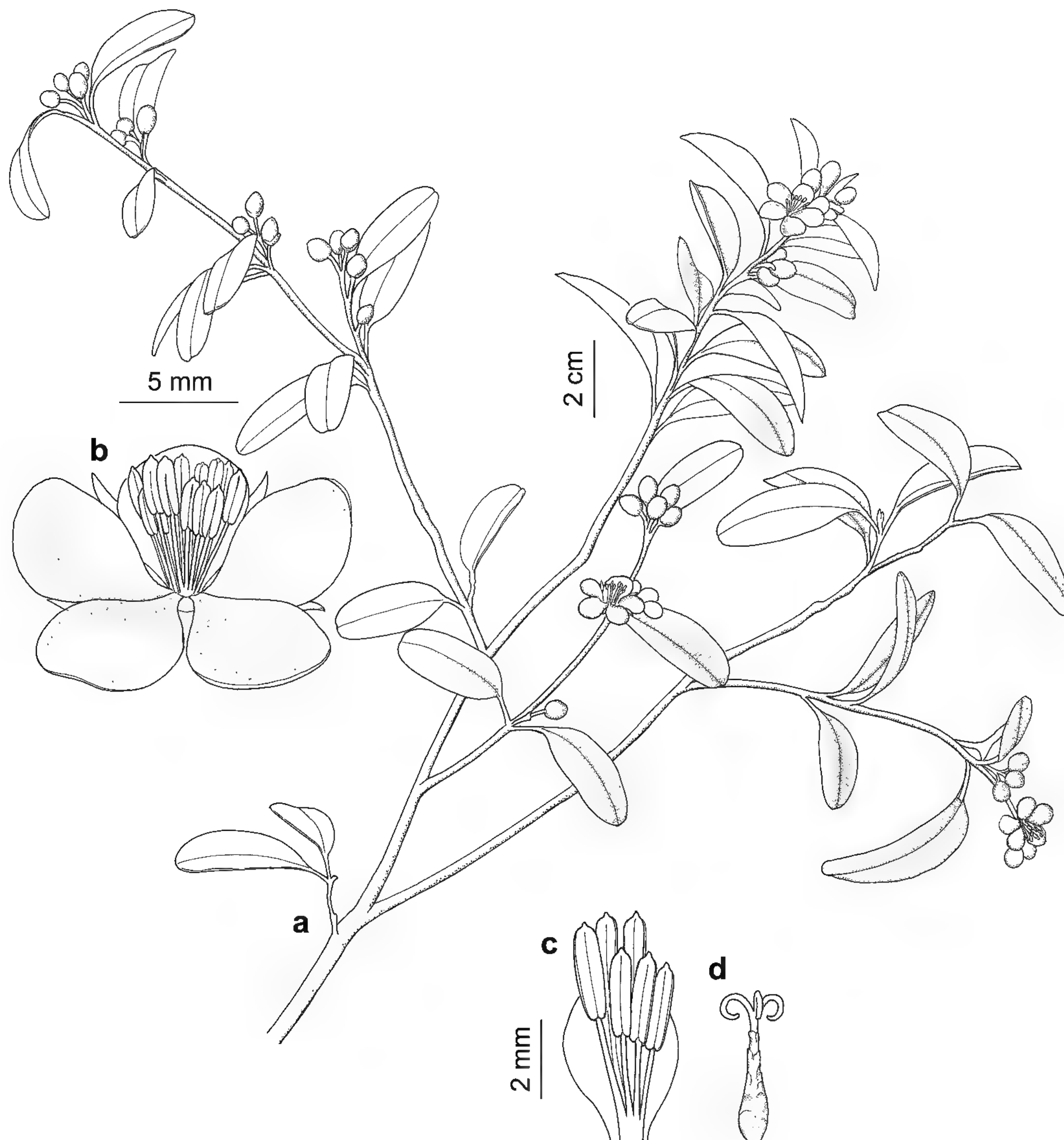

Figure 3. *Helmiopsis polyandra* Appleq. —A. Flowering branch. —B. Flower. —C. Cluster of stamens. —D. Gynoecium. Based on the type, *Service Forestier* 27532.

ovoid or cylindrical, grayish brown, with irregular surface, lepidote; seeds unknown.

Distribution, phenology, and habitat. This new species is known only from a few sites in the extreme northeast of Madagascar (Fig. 1); one collection is recorded from 300 m altitude. Buds and flowers have been collected in March; the only fruit seen, also collected in March, was old fruit that remained on the plant from the previous flowering period.

IUCN Red List category. Provisional IUCN Red List category (2001) is noted as Vulnerable (VU D2).

Only three distinct populations have been collected; if area of occupancy were calculated using a 4 km² cell, as suggested by IUCN (2001), the range of this species would be only 12 km². It seems to be limited to a relatively small portion of Madagascar that, like much of the country, has suffered significant deforestation (e.g., Du Puy & Moat, 2003).

Discussion. Known specimens of this species have been previously identified as *Helmiopsis hily*, apparently due to their relatively narrow leaves and variable color differences between leaf surfaces. However, the

affinities of *H. polyandra* to *H. boivinii* seem much greater; for example, *H. hily* has strongly lobed ovaries and relatively few stamens. The former two species also share a geographic range in the extreme north, whereas *H. hily* is a southern and western species. *Helmiopsis boivinii* may be distinguished from *H. polyandra* by its frequently ovate leaves, whose abaxial surfaces are not so distinctly paler than the adaxial surfaces; its pedicels are (6–)8–16(–19) mm long, and its petals are (6–)10–13 mm long, obovate to obdeltoid rather than suborbicular. Additionally, *H. boivinii* has only (15 to)20 to 25 stamens, and the staminodes are spatulate and 2.8–4(–5) mm long; the bracteoles may be smaller (ca. 1 mm) and are more frequently lost even on very small buds.

Service Forestier 23078bis is a sterile specimen whose leaves, sparsely lepidote on both surfaces at maturity, are much larger than those of the three collections of *Helmiopsis polyandra* from closer to Iharana. As its appearance (including leaf shape, venation, bark, and stipule morphology) is generally consistent with that of the known specimens of *H. polyandra*, it is placed therein.

Paratypes. MADAGASCAR. **Antsiranana:** lisière supérieure de la forêt d'Andranomadiro [12°38'S, 049°28'E] (rebord S du plateau de Sahafary, entre les bassins de la Saharenana et du Rodo [Irodo]), *Service Forestier 23078bis* (P); forêt d'Analafiana, au N de la basse Manambery (au SW de Vohémar), *Service Forestier 27516* (MO, P); massif du Bezavona [13°32'S, 049°54'E] (entre la Fanambana et la Manambery), pentes inférieures de la rive droite de l'Andilana, *Service Forestier 27540* (MO, P).

II. *Helmiopsis* sect. *Glandulipetalae* Arènes, Bull. Mus. Natl. Hist. Nat., sér. 2, 28: 416. 1956. TYPE: *Helmiopsis pseudopopulus* (Baill.) Capuron ex Arènes, designated here [\equiv *Dombeya pseudopopulus* Baill.].

Trees, sometimes large, or large shrubs; twig bark grayish to dark reddish brown, shallowly ridged, with small pale lenticels; young twigs usually lepidote or bearing scurfy scales. Leaves broad, ovate to broadly elliptical, orbicular, or occasionally obovate; petiole lepidote; basal veins 5 to 7, well developed; base shallowly cordate to rounded-truncate or rounded; apex variable; margins entire to weakly repand, crenulate, or crenate-serrate; at least the abaxial surface lepidote; stipules small, lanceolate or scurfy, rapidly caducous. Inflorescences lateral and sometimes terminal, cymose with up to several orders of branching or geminate; bracts lanceolate, immediately caducous; bracteoles lanceolate, inserted immediately or well below bud, immediately caducous; pedicels \pm angular, sometimes articulated; inflorescences lepidote throughout. Sepals lanceolate, lepidote, normally bearing small inconspicuous glandular patches at the very base of the adaxial

surface; petals white to creamy or yellowish, obovate, \pm glandular on lower portion of adaxial surface; fused base of androecium coroniform; fertile stamens normally 10 (rarely 5 or 15 in aberrant flowers), borne in pairs, \pm oppositipetalous; filaments short, anthers linear; staminodes spatulate, longer than fertile stamens; gynoecium 5-carpellate; ovary lepidote, often 5-lobed; style lepidote basally to throughout; style lobes erect, clustered. Inflorescence branches usually lengthening and becoming woody in fruit; fruit a capsule, ovoid or subspherical, often 5-lobed; seeds (1 to)2 per locule, only 1 well developed, with a prominent apical wing or unwinged in 1 species.

Distribution. *Helmiopsis* sect. *Glandulipetalae* is confined to forested areas in the extreme north of Madagascar (Fig. 4). A variety of substrate types are reported.

Discussion. Arènes (1956b, 1959) did not specify a type species for this section. *Helmiopsis pseudopopulus* is therefore selected herein as type for section *Glandulipetalae*.

KEY TO THE SPECIES OF *HELMIOPSIS* SECT. *GLANDULIPETALAE*
IN MADAGASCAR

- 1a. Leaves transversely elliptical, breadth well exceeding length; inflorescences geminate or cymose with up to 6 (rarely to 12) buds; petals 15–26 mm long; capsule ca. 18–23 mm long 6. *H. bernieri*
- 1b. Leaves broadly ovate to orbicular, occasionally elliptical, obovate, or depressed-ovate; inflorescences repeatedly branched cymes; petals less than 15 mm long; capsule not over 18 mm long.
 - 2a. Leaves broadly ovate to orbicular; basal veins 5; apex acuminate; margins entire to shallowly repand or rarely crenulate; petals (7–)11–13 (–15) mm long, basal adaxial surface usually sparsely to moderately glandular; ovary and fruit not strongly lobed 8. *H. richardii*
 - 2b. Leaves variable in shape; basal veins 5 to 7; margins crenulate to shallowly repand or crenate-serrate; petals 7–11.5 mm long, basal adaxial surface densely glandular; ovary and fruit strongly 5-lobed.
 - 3a. Leaf margins weakly crenate to repand; basal veins (5 to)7; venation not prominently raised; style lepidote only beneath; ovules and seeds winged 7. *H. pseudopopulus*
 - 3b. Leaf margins crenate-serrate; basal veins 5 to 7; venation prominently raised; style sometimes lepidote throughout; ovules and seeds not winged 9. *H. sphaerocarpa*

6. *Helmiopsis bernieri* (Baill.) Arènes, Bull. Mus. Natl. Hist. Nat., sér. 2, 28: 416. 1956. Basionym: *Dombeya bernieri* Baill., Bull. Mens. Soc. Linn. Paris 1: 500–501. 1885. TYPE: Madagascar. Lingvatou [12°26'S, 049°30'E], (fl.), *J. Bernier* (2^{me} envoi) 338 (holotype, P!; isotypes, BM not seen, G not seen, P!).

Small tree, to 7–8 m high, or large shrub; twig bark grayish, shallowly ridged, with small pale lenticels; young twigs ferruginous, densely lepidote. Leaves transversely elliptical to barely reniform, (2–)2.5–5.5(–7) × (2.2–)3.5–8(–11) cm, coriaceous; petiole (1–)1.5–3(–4.8) cm, densely lepidote; basal veins 5; base rounded-truncate to broadly rounded or very shallowly cordate; apex rounded, occasionally short-acuminate; margins entire to weakly repand; both surfaces lepidote, densely so in young leaves, with scales of variable size and coloration; stipules ca. 1.5–3 mm, scaly to lanceolate, usually immediately caducous. Inflorescences few-flowered, geminate or with up to 6(to 12) buds, mostly clustered at twig apices on short thick peduncles (usually 1–1.5 cm), sometimes subtended by small leaves, or individual lateral inflorescences borne on peduncles to 5(–8.5) cm; only 1 flower per inflorescence maturing at a time; bracts lanceolate, (3.2–)4.4–6.3 mm, rapidly caducous; bracteoles lanceolate, keeled, (3.5–)4.2–5.5(–6.8) mm, inserted just below bud, rapidly caducous; pedicels thick, ± angular, articulated, 2–6(–9) mm; inflorescences lepidote throughout. Sepals narrowly lanceolate, 14–17 mm, lepidote, reflexed at maturity, bearing small patches of glandular tissue at base of adaxial surface; petals whitish with a creamy or pale yellowish tinge, (15–)19–24(–26) × (13–)19–26(–29) mm, broadly obovate and often broader than long, adaxial surface basally glandular; androecial corona 1–2 mm; fertile stamens 10, oppositipetalous in pairs; filaments (1.5–)2–2.5 mm; anthers linear, 4–5.8(–6.4) mm; staminodes spatulate, 8–11 mm, oppositisepalous; gynoecium 5-carpellate; ovary lepidote, weakly 5-sided; style lepidote, 4.5–5(–5.8) mm; style lobes erect, clustered, (1–)1.5–2.3 mm; ovules up to 6 per locule. Inflorescence becoming woody in fruit; fruit a woody capsule, ovoid, ca. 18–23 mm, shallowly 5-lobed with a short apical nipple, lepidote; young seeds with a long apical wing, mature seeds not known.

Distribution, phenology, and habitat. *Helmiopsis bernieri* is confined to a very small region of extreme northern Madagascar in the vicinity of Antsiranana (Diégo-Suarez; Fig. 4) and grows on sand in sometimes degraded forested areas. Flowering is recorded from November through March; the only fruiting collection known was made in November.

IUCN Red List category. Provisional IUCN Red List category (2001) is noted as Vulnerable (VU D2). No more than five clearly distinct locations and two distinct populations are known; all collections of *Helmiopsis bernieri* have been from a limited range, such that a single natural disaster could affect all populations simultaneously, and most of the forest remaining in these areas is not formally protected.

Discussion. *Helmiopsis bernieri* is a very distinctive species, easily distinguished by its transverse-elliptical leaf shape; it also has the largest flowers and fruits in the genus.

Specimens examined. MADAGASCAR. **Antsiranana:** Baie de Rigny [12°26'S, 049°32'E], *Bernier 2603* (P); S of Pic Raynaud, S rte. de la Baie de Rigny, *Service Forestier 20361* (MO [2], P); forêt d'Orangea [12°15'S, 049°23'30"E], *Service Forestier 20937* (MO, P); Diégo-Suarez, près d'Antsoha, piste d'Androfiabe à la baie de Rigny, *Service Forestier 23039* (MO [2], P); forêt d'Orangea [12°15'S, 049°23'30"E], *Service Forestier 23274* (MO, P).

7. *Helmiopsis pseudopopulus* (Baill.) Capuron ex Arènes, as "*Pseudo-Populus*," Bull. Mus. Natl. Hist. Nat., sér. 2, 28: 416. 1956. Basionym: *Dombeya pseudopopulus* Baill., as "*pseudo-Populus*," Bull. Mens. Soc. Linn. Paris 1: 500. 1885. TYPE: Madagascar. Prov. Antsiranana: Lingvato [12°26'S, 049°30'E], s.d. (fl.), *J. Bernier (2e envoi) 339* (holotype, P!; isotypes, G not seen, P!).

Tree to 10(–20) m high, to 20 cm diam., or large shrub to 6 m high; twig bark grayish to reddish brown, shallowly ridged, with small pale lenticels; young twigs pale, lepidote. Leaves broadly ovate to orbicular, sometimes depressed-ovate, 3.2–10.5 × 4–10 cm; petiole 2.7–7.5(–10.5) cm, densely lepidote, slightly reddish; basal veins 7 or rarely 5; base cordate or occasionally rounded-truncate; apex acuminate to acute, cuspidate, or occasionally rounded; margins shallowly crenate to shallowly repand; both surfaces lepidote, often sparsely so on larger leaves, the abaxial surface slightly grayish green with pale nerves, the adaxial surface slightly yellowish; stipules lanceolate to linear, 2–6 mm, immediately caducous and almost never present. Inflorescences cymose with few orders of branching, axillary and sometimes terminal or pseudoterminal, clustered near distal ends of branches; peduncle (2.4–)3.5–6.5(–8.8) cm, inflorescences in total (4.2–)7–13(–14.6) cm; bracts immediately caducous; pedicels 5–9 mm, ± angular, articulated; bracteoles inserted well below flower, immediately caducous; inflorescences and pedicels lepidote. Sepals lanceolate, 5–7 mm, lepidote, reflexed at maturity, yellowish, bearing small glandular patches inside at base; petals creamy or white, (7–)8.5–11.5 × (4.5–)5–8 mm, broadly obovate, lower portion of adaxial surface usually densely glandular; androecial corona 1.1–2 mm; fertile stamens 10 (rarely 15 in aberrant flowers), borne in pairs, usually ± oppositipetalous; filaments (0.6–)1.5–2 mm, fused for at least half their length; anthers linear, 1.6–2.4(–2.7) mm, orange; staminodes spatulate, 3.9–4.8 mm, usually oppositisepalous, at least sometimes yellow at the apex; gynoecium 5-carpellate; ovary lepidote, 5-

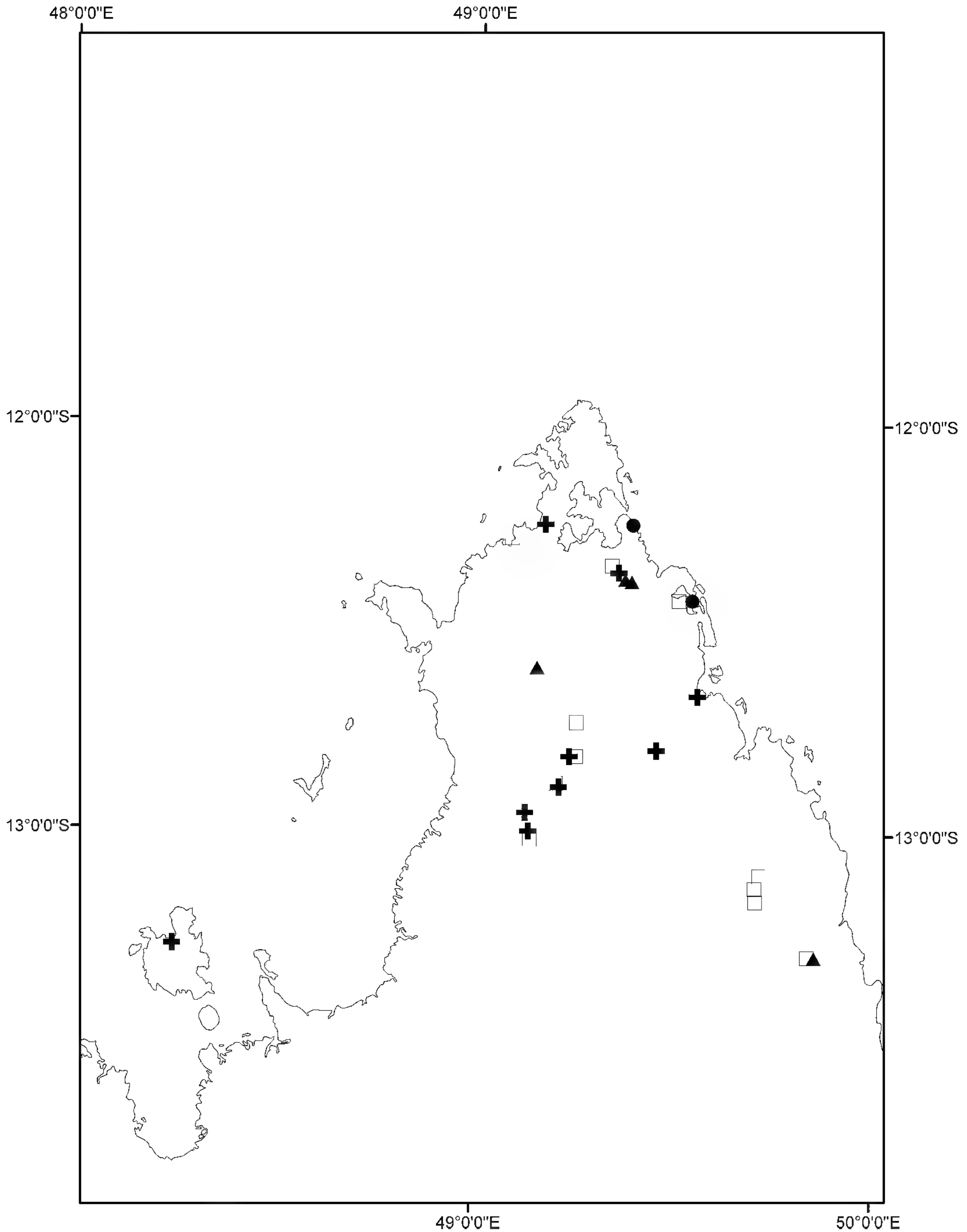

Figure 4. Approximate distribution of species of *Helmiopsis* sect. *Glandulipetalae* in northern Madagascar (● — *H. bernieri*; □ — *H. pseudopopulus*; ⊕ — *H. richardii*; ▲ — *H. sphaerocarpa*).

lobed; style lepidote on basal third to half, 3.5–5 mm, white; style lobes erect, clustered, 0.5–1.5 mm, orange. Inflorescence branches lengthening and becoming woody in fruit; capsule ovoid and deeply

5-lobed, (9–)12–18 mm, immature fruit golden greenish (tan when dried, possibly darkening with age), lepidote, persistent sepals often present; apex acute, sometimes beaked or rounded; inner surfaces of

locules glabrous; seeds 2 per locule, only 1 well-developed, at maturity ca. (3–)4.5–6 mm, with 6–8 mm apical wing.

Distribution, phenology, and habitat. *Helmiopsis pseudopopulus* is native to a limited region of northern Madagascar (Fig. 4). Its collected habitat is forest, including gallery forest; one collection is at the shore. Altitude ranges to at least 300 m, and possibly as high as 450 m. No strong substrate preference is clear; collections have been made on limestone, on basalt, and at a locality with substrate including sand and rocks. Most flowering specimens are recorded from January to April (two November-flowering specimens have been collected from Montagne des Français); undehisced fruits have been collected from March to May, and mature fruit with seeds still present in August. Flowers have been noted to have a *Malus*-like scent (Nusbaumer & Ranirison 1177).

IUCN Red List category. Provisional IUCN Red List category (2001) is noted as Least Concern (LC).

Common names. Hafomena (*Service Forestier* 9389).

Nomenclature and orthography. The orthography of the specific epithet of *Helmiopsis pseudopopulus* must be corrected to remove the hyphen, according to Article 60.9 of the ICBN (McNeill et al., 2006: cf. Ex. 20). This combination was first made by Capuron in Vol. 14, Fascicle 4 of *Notulae Systematicae* (Paris), which was dated on the front cover “Décembre 1952” (and which was received in libraries early enough in 1953 to indicate there was no lengthy delay in publication). However, the back cover gives 1953 as the publication date, and this is believed to be the more accurate source of information. Unfortunately, Article 33.4 of the ICBN (McNeill et al., 2006) required that new combinations published after 1 January 1953 provide a full and direct reference to the basionym’s place of publication. Capuron’s combination was therefore not validly published; it was validated by Arènes (1956).

Representative specimens examined. MADAGASCAR. **Antsiranana:** Ambilobe, massif de l’Ankarana, Ambilomagogdro partie E, savane de bordure, 13°01’20”S, 049°08’14”E, *Bardot-Vaucoulon et al.* 1366 (MO, TAN); Daraina, sous-préfecture de Vohemar, forêt de Bekaraoka, partie sud, en aval d’Andranotsimaty, en direction du point coté 112, 13°09’59”S, 049°42’07”E, *Gautier et al.* 4383 (MO); pentes du Lac Sacre [– Antanavo] près Anivorano-Nord [12°44’S, 049°15’E], *Humbert* 32322 (MO, P); Montagne des Français [12°22’S, 049°21’E], *Keraudren* 1672 (MO, P); Mantamena, part of Bekaroaka Range, 7 km NE Daraina (Vohémar), 13°08’S, 049°42’E, *Meyers & Boltz* 167 (MO, TAN); sous-préfecture de Vohemar, commune rurale de Daraina, forêt de Bekaraoka, partie N, 13°06’11”S, 049°42’39”E, pente 22°, orientation 330°, bas de pente,

Nusbaumer & Ranirison 1177 (MO); Ankara, Diégo-Suarez, *Service Forestier* 5438 (MO, P, TAN); Ankara, Diégo-Suarez, *Service Forestier* 9389 (P); Montagne des Français, vallée de la’Andavakoera, *Service Forestier* 20922 (MO, P); Montagne des Français, Pic des Orchidées, *Service Forestier* 23250 (MO, P); en bordure de mer, près d’Ankingameloka (baie d’Ambararata, Diégo-Suarez) [12°17’S, 049°05’E], *Service Forestier* 24661 (MO, P); près de Marotaolana (Anivorano-Nord) [12°49’S, 049°15’E], *Service Forestier* 24717 (P); calcaires lapiazés de l’Ankarana, près d’Ambondromifehy [12°53’S, 049°12’E], *Service Forestier* 24730 (MO, P); versant E du massif de l’Ankerana (partie S du massif de Mafokovo [ca. 13°18’S, 049°50’E], au N de Vohémar, *Service Forestier* 27412 (MO [2], P).

8. *Helmiopsis richardii* (Baill.) Capuron ex Arènes, *Bull. Mus. Natl. Hist. Nat.*, sér. 2, 28: 416. 1956. Basionym: *Trochetia richardii* Baill., as “*Richardii*,” *Adansonia* 10: 108. 1871. *Dombeya richardii* (Baill.) Baill., as “*Richardii*,” *Bull. Mens. Soc. Linn. Paris* 1: 500. 1885. TYPE: Madagascar. Prov. Antsiranana: Nossi-Bé [Nosy Be 13°17’S, 048°15’E], (fl.), *J. M. C. Richard* 343 (holotype, P!; isotype, P!).

Tree to 15 m high, at least 20 cm DBH; twig bark grayish to reddish brown, shallowly ridged, with small pale lenticels; young twigs pale, lepidote. Leaves broadly ovate to orbicular, (3–)4.2–8.7(–11.3) × 3.1–8.4(–10.8) cm, thick-textured; petiole (1.7–)3–6.8(–8.3) cm, densely lepidote; basal veins 5; base shallowly cordate to rounded-truncate or rounded; apex acuminate; margins entire to weakly repand or very rarely shallowly crenate; both surfaces lepidote, the abaxial surface pale green; stipules ca. 2–2.5 mm, lepidote and sometimes possibly dark-margined, immediately caducous. Inflorescences cymose with few orders of branching, lateral, clustered at distal ends of twigs; peduncle 2.5–5(–7.5) cm; branches of inflorescence compact, inflorescences in total 5.5–12 cm; bracts immediately caducous; pedicels (3–)9–15(–20) mm, ± angular, articulated; bracteoles inserted well below flower, immediately caducous; inflorescences and pedicels lepidote. Sepals narrowly lanceolate, (4–)6.5–10.4 mm, lepidote, yellow-green with brownish scales, reflexed at maturity, usually bearing small glandular patches inside at base; petals white to creamy or greenish white or pale yellow, (7–)11–13(–15) × (5–)6–8(–10) mm, broadly obovate, lower portion of adaxial surface sparsely to moderately glandular or subglabrous; androecial corona 1.2–1.9(–2.4) mm; fertile stamens (5 to)10, borne in pairs or rarely singly, usually ± oppositipetalous; filaments (1–)1.5–2 mm, fused for half their length, white; anthers linear, (1.6–)2.4–4(–4.3) mm, brown; staminodes spatulate, (4.5–)5–8.5 mm, usually oppositise-palous; gynoecium 5-carpellate; ovary lepidote; style lepidote on basal portion to lower third, 4.2–6(–7.5)

mm; style lobes erect, clustered, 1–1.8 mm. Inflorescence branches lengthening and becoming woody in fruit; capsule ovoid, (7–)11–18 mm, tapering or shorter and truncate with or without a small beak, internally glabrous, dehiscing from the apex, reddish brown, lepidote; seeds 2 per locule, only 1 well developed, in larger fruits ca. 4.5–5 mm with 7–8 mm apical wing, in small fruits ca. 3–4 mm with wing ca. 3–5.4 mm.

Distribution, phenology, and habitat. *Helmiopsis richardii* is native to a limited region of northern Madagascar (Fig. 4). Its collected habitat is forest on a variety of soil types, but especially on calcareous substrates, sometimes near rivers. The reported altitude range is from 90 to at least 200 (possibly to 350) m. The recorded flowering period is (November to) February to April; mature fruits with seeds have been collected in April (Ankarana), July (Montagne des Français), and October (Baie de Diégo-Suarez). Flowers have been reported to smell slightly of fish (Cheek et al. B1408).

IUCN Red List category. Provisional IUCN Red List category (2001) is noted as Least Concern (LC).

Common names. Miriky (*Service Forestier 9432*); Selimavo (*Service Forestier 15061*); Sely (*Service Forestier 14883*).

Discussion. This species bears considerable general resemblance to *Helmiopsis pseudopopulus*, but can be distinguished by its unlobed ovary and fruit and by its more sparsely glandular petals; the basal portion of the petals of *H. pseudopopulus* bears a fairly dense and even coating of small glands, except where these have been lost to disturbance, whereas those of *H. richardii* have relatively few, unevenly distributed glands. On average, *H. richardii* has slightly larger flowers, with larger sepals, petals, and androecial parts (sepals mostly over 7 mm, anthers mostly over 2.4 mm, staminodes mostly over 5 mm) and longer pedicels (usually over 9 mm). Unfortunately, the type of *H. richardii* represents the smallest extreme of that species' floral size range, perhaps because it is from a geographically and genetically distinct population (the island of Nosy Be), although the specimen is not in ideal condition. Little fruiting material referable to *H. richardii* is known, but it encompasses fruits with two distinct morphologies. Fruits collected at Baie de Diégo-Suarez and Ankarana have a blunt apex with a short acute tip, while fruits from Montagne des Français are longer and have a tapering apex. More collection is certainly desirable.

Leaves of *Helmiopsis pseudopopulus* have shallowly crenate to undulate margins and apices that may range from acuminate to acute, cuspidate, or rounded. The

breadth of the leaves in *H. pseudopopulus* not infrequently exceeds the length, which is very rare in *H. richardii*; the basal veins almost always number seven, rarely five. Leaves of *H. richardii* are entire to shallowly undulate, but usually not shallowly crenate, relatively narrower and sometimes more graceful in appearance, with consistently acuminate apices; there are normally five basal veins. There is enough overlap in leaf morphology that sterile specimens may be very difficult to identify; the variation in basal leaf vein number may be the most useful character.

Two specimens from Ankarana have particularly unusual morphology: *Humbert 32551* (MO [2]) has typical *Helmiopsis richardii* floral morphology but prominently crenate-serrate leaves (with only five basal veins), while *Service Forestier 29220* (MO) has unlobed, narrowly elongated young fruits but slightly crenate leaves (with five to nine basal veins) and very small flowers on short pedicels (to 3 mm vs. a minimum of 6 mm in other collections). Typical *H. richardii* and *H. pseudopopulus* have both been collected from the Ankarana region, and the two species are clearly closely related. Hybridization between them may be possible and may account for these two intermediate specimens.

Nomenclature and orthography. As for *Helmiopsis pseudopopulus*, discussed above, the combination *H. richardii* was first made by Capuron (1952); an unfortunately timed publication delay rendered both combinations invalid under Article 33.4 of the ICBN (McNeill et al., 2006). The combination was validated by Arènes (1956), who simultaneously introduced the correct spelling of the epithet, the originally published Latin termination (“*richardi*”) being an error requiring correction under Article 60.11 of the ICBN (McNeill et al., 2006).

Representative specimens examined. MADAGASCAR. **Antsiranana:** S of Anivorano Nord, env. Ambalabao, ca. 12°48'S, 049°14'E, Cheek et al. B1408 (TAN); Ankarana Special Reserve, ca. 5 km NW of Park Village near Besaboba stream, 12°57'16"S, 049°07'30"E, Harder et al. 1725 (MO); collines et plateaux calcaires de l'Analamera, *Humbert 19244* (P); plateaux calcaires de l'Ankarana du N entre Ambilobe et Anivorano, *Humbert & Capuron 25558* (P); environ de Diégo-Suarez, Montagne des Français [12°22'S, 049°21'E], *Keraudren 1646* (MO, P); Nosy Be [13°17'S, 048°15'E], *Richard 317* (P); plateau calcaire de l'Ankarana, au NE d'Ambondromifehy [12°53'30"S, 049°12'30"E], *Service Forestier 3040bis* (P); Antafiamatso–Diego [12°40'S, 049°33'E], *Service Forestier 9432* (P); Baie Diégo-Suarez, *Service Forestier 14883* (P); Montagne des Français, Diégo-Suarez [12°22'S, 049°21'E], *Service Forestier 15061* (MO, P); plateau calcaire de l'Ankarana, à l'W d'Ambondromifehy (J.B. 8) [12°53'S, 049°12'E], *Service Forestier 22694* (MO, P); plateau de l'Ankarana, rebord S du Plateau de Mahory (rive gauche du haut Rodo) [12°49'S, 049°14'E], *Service Forestier 23144* (P); massif de l'Ambongoabo, entre la baie de

Diégo et celle du Courier [12°15'S, 049°10'E], *Service Forestier 24644* (MO [2], P).

9. *Helmiopsis sphaerocarpa* L. C. Barnett, *Ann. Missouri Bot. Gard.* 74: 450. 1987. TYPE: Madagascar. Prov. Antsiranana: massif de la Montagne d'Ambre [ca. 12°36'S, 049°09'E], crête entre les bassins de la rivière des Makis et de la rivière d'Ankazobe, 600–800 m, 26–27 May 1970 (fl.), *Service Forestier 29194* (holotype, P!; isotypes, K not seen, MO!, P [2]!, TEF not seen).

Tree to at least 14 m high, 11 cm diam., or large shrub; twigs sturdy; bark fibrous, dark, somewhat reddish brown, shallowly ridged, with small pale lenticels; youngest twigs sometimes lepidote, with small scurfy fimbriate scales. Leaves broadly ovate to ovate or elliptical, or occasionally obovate or suborbicular, 5–13 × 3.5–9 cm; petiole (0.8–)2–5 (–7.8) cm, sparsely lepidote; basal veins 5 to 7; base shallowly cordate or occasionally rounded; apex acute to short-acuminate or rounded; margins crenate to crenate-serrate; adaxial surface glabrous or nearly so, abaxial surface sparsely lepidote, mostly along veins; venation conspicuous on both surfaces, prominent abaxially; stipules lanceolate, ca. 4–5 mm, rapidly caducous. Inflorescences cymose with several orders of branching, terminal and lateral, clustered near branch ends; peduncles 2–8 cm, inflorescences in total 6.5–15 cm, with lower internal branches well developed; bracts narrowly lanceolate, rapidly caducous; pedicels 2.5–6(–8) mm, ± angular; bracteoles inserted immediately below flower, rapidly caducous; inflorescences and pedicels lepidote. Sepals lanceolate, 5.2–6.5 mm, lepidote, yellowish, usually bearing small glandular patches inside at base; petals white, 7–10 × 6–8.5 mm, broadly obovate with asymmetrical apex, lower third of adaxial surface densely glandular; androecial corona 0.6–1.3 mm; fertile stamens 10, borne in pairs, ± oppositipetalous; filaments 0.7–2.2 mm, free to corona; anthers linear, 1.7–2.6 mm; staminodes spatulate, 5–5.8 mm, white, ± oppositisepalous; gynoecium 5-carpellate; ovary lepidote, 5-lobed; style lepidote basally or for entire length, 3.5–5.5 mm, whitish yellow; stigma lobes erect, clustered, ca. 0.5–0.8 mm. Inflorescence branches becoming woody in fruit; capsule subspherical, 5-lobed, 5.4–7 mm, dark brown, lepidote; apex rounded-truncate with small apical projection; fruit subtended by hardened persistent sepals; inner surfaces of locules glabrous; seeds 1 to 2 per locule, only 1 well developed, at maturity ca. 5–6 mm, irregularly rounded-triangular, ± laterally compressed, wingless except for inconspicuous keel.

Distribution, phenology, and habitat. *Helmiopsis sphaerocarpa* is native to a limited range of sites in

northern Madagascar (Fig. 4). The few known collections are from mountainous areas, one noted to be in dry deciduous forest, and the preferred habitat is probably rocky; reported altitudes range from 233 m to 600–800 m. Flowers have been collected in May and June, with mature fruits with seeds still present in September and December.

IUCN Red List category. Provisional IUCN Red List category (2001) is noted as Vulnerable (VU D2). Fewer than five locations are known. Other species of *Helmiopsis* from the same region have been more widely and frequently collected, suggesting that this species is relatively rare.

Common names. Selivato (*Service Forestier 5673*); Sely (*Rakotondrafara et al. 268*).

Discussion. Barnett (1987), in the original publication of *Helmiopsis sphaerocarpa*, suggested that this species is likely the sister taxon of *H. pseudopopulus*, with which it shares a number of vegetative, inflorescence, and floral characters or tendencies. The two can be distinguished in the vegetative state, as the leaves of *H. sphaerocarpa* are coarser in appearance, more conspicuously crenate, and closer to glabrous. The midrib and secondary veins are prominently raised on the abaxial surface for virtually their entire length and often conspicuously paler or darker than the leaf surface, whereas in *H. pseudopopulus* the secondary veins are weaker, often scarcely raised toward the distal ends, and not strongly colored. The fruit of *H. pseudopopulus* is larger (usually 12–18 mm long) and the seeds have a substantial apical wing, which is not present in *H. sphaerocarpa*. The sepals of *H. pseudopopulus* often persist during fruit maturation but never become as thick and woody as those of *H. sphaerocarpa*. Several small differences in floral morphology also separate the two species; for example, the filaments of stamen pairs in *H. pseudopopulus* are fused near the base, and the style is lepidote only on the lower portion.

Specimens examined. MADAGASCAR. **Antsiranana:** Sous-préfecture Antsiranana II, Commune Mahavanona, Fokontany Andranomanitra, Ampitiliantsambo, 15 km NE d'Andranomanitra, 12°23'18"S, 049°22'57"E, *Rakotondrafara et al. 268* (MO); Diégo-Suarez, Montagne des Français [12°22'S, 049°21'E], *Service Forestier 5673* (P); versant E du massif de l'Ankerana (partie S du massif de Mafokovo [ca. 13°18'S, 049°50'E]) au N de Vohémar, *Service Forestier 27349* (MO, P).

SPECIMINA INCERTAE SEDIS

Helmiopsis sp. indet.: Madagascar. Prov. Antsiranana: forêt d'Analamahitsy (PK. 84 de la rte. Diégo–Ambilobe), entre Anivorano et Ambondromifehy

[12°48'S, 049°14'E], 22 Apr. 1963, *Service Forestier* 22669 (MO [2], P).

This collection, a white-flowered tree 15–18 m high, has been previously determined as *Helmiopsis pseudopopulus*; it has also been determined twice as “*H. angulata*,” a name used first by Capuron in sched. but apparently never published by him or any succeeding author. The general appearance is consistent with *H. pseudopopulus*, except that the inflorescences are unusually long (to 18 cm in flower). However, the petals are narrower (4–5 mm broad, with the breadth being less than half the length); the petal glands are very sparse rather than plentiful; the style is longer than usual (5.5–6.2 mm), bent or kinked below the stigmas, and lepidote for over half its length; and the staminodes are somewhat longer than usual (4.7–5.7 mm). This collection may well represent a distinct—and undoubtedly rare and endangered—species; however, since its locality is within the range of *H. pseudopopulus*, the possibility that it is a very unusual individual or distinct variety of that species cannot be ruled out. Further investigation and collection of populations along Route Nationale 6 would be highly desirable.

Literature Cited

- Applequist, W. L. 2009. Two new species of *Dombeya* (Malvaceae) from Madagascar. *Novon* 19: 289–294.
- Arènes, J. 1956a. Contributions à l'étude des Sterculiacées de Madagascar. VII. Sur le genre *Helmiopsis* H. Perr. *Mém. Inst. Sci. Madagascar*, sér. B, 7: 55–57.
- . 1956b. Contribution à l'étude des Sterculiacées de Madagascar. XIX. Mise au point sur le genre *Helmiopsis* H. Perr. *Bull. Mus. Natl. Hist. Nat.*, sér. 2, 28: 412–418.
- . 1958. Les *Dombeya* de Madagascar et des Comores. *Candollea* 16: 247–449.
- . 1959. Sterculiacées. *Fl. Madagasc.* 131: 1–537.
- Barnett, L. J. 1987. An unusual new species of *Helmiopsis* H. Perrier (Sterculiaceae) from Madagascar. *Ann. Missouri Bot. Gard.* 74: 450–452.
- Bayer, C., M. F. Fay, A. Y. de Bruijn, V. Savolainen, C. M. Morton, K. Kubitzki, W. S. Alverson & M. W. Chase. 1999. Support for an expanded family concept of Malvaceae within a recircumscribed order Malvales: A combined analysis of plastid *atpB* and *rbcL* DNA sequences. *Bot. J. Linn. Soc.* 129: 267–303.
- Bosser, J. & R. Rabevohitra. 1996. Taxa et noms nouveaux dans le genre *Dalbergia* (Papilionaceae) à Madagascar et aux Comores. *Bull. Mus. Natl. Hist. Nat.*, sér. 4, sect. B, *Adansonia* 18: 171–212.
- Capuron, R. 1952 [1953]. Identité des genres *Nesogordonia* H. Bn. et *Cistanthera* K. Schum. et description de deux espèces nouvelles de Madagascar. *Notul. Syst. (Paris)* 14: 258–263.
- Dorr, L. J. 2001. A new combination in the endemic Malagasy genus *Helmiopsis* (Malvaceae-Dombeyoideae). *Adansonia*, sér. 3, 23: 151–153.
- Du Puy, D. J. & J. Moat. 2003. Using geological substrate to identify and map primary vegetation types in Madagascar and the implications for planning biodiversity conservation. Pp. 51–74 in S. M. Goodman & J. P. Benstead (editors), *The Natural History of Madagascar*. University of Chicago Press, Chicago.
- Hochreutiner, B. P. G. 1926. Monographie des *Dombeya* de Madagascar. *Candollea* 3: 5–120.
- IUCN. 2001. IUCN Red List Categories and Criteria, Version 3.1. Prepared by the IUCN Species Survival Commission. IUCN, Gland, Switzerland, and Cambridge, United Kingdom.
- Jongkind, C. C. H. 1995. Prodrômus for a revision of *Combretum* (Combretaceae) for Madagascar. *Bull. Mus. Natl. Hist. Nat.*, sér. 4, sect. B, *Adansonia* 17: 191–200.
- Lowry, P. P. II, T. Haevermans, J.-N. Labat, G. E. Schatz, J.-F. Leroy & A.-E. Wolf. 2000. Endemic families of Madagascar. V. A synoptic revision of *Eremolaena*, *Pentachlaena* and *Perrierodendron* (Sarcocaulaceae). *Adansonia*, sér. 3, 22: 11–31.
- McNeill, J., F. R. Barrie, H. M. Burdet, V. Demoulin, D. L. Hawksworth, K. Marhold, D. H. Nicolson, J. Prado, P. C. Silva, J. E. Skog, J. H. Wiersema & N. J. Turland. 2006. International Code of Botanical Nomenclature (Vienna Code). *Regnum Veg.* 146.
- Perrier de la Bâthie, H. 1944. Les genres *Nesogordonia* Baillon et *Helmiopsis* g. n. de Madagascar. *Bull. Soc. Bot. France* 91: 226–232.
- Vogel, S. 2000. The floral nectaries of Malvaceae *sensu lato*—A conspectus. *Kurtziana* 28: 155–171.

A REVISION OF NEOTROPICAL *BONYUNIA* (LOGANIACEAE: ANTONIEAE)¹

Jason R. Grant²

ABSTRACT

A revision of the Neotropical genus *Bonyunia* M. R. Schomb. ex Progel (Loganiaceae, Antonieae) is provided, including a key to species, description, distribution, IUCN Red List status, and discussion. *Bonyunia* is morphologically and ecologically diverse with taxonomically informative characters that include habit, seed and leaf morphology, and the shape and indument of the calyx, bracts, and bracteoles. *Bonyunia* occurs in lowland regions of the Amazon River watershed (Brazil and Bolivia), the Orinoco River watershed (Colombia and Venezuela), tepuis of the Guayana region and outliers (Brazil, Guyana, Venezuela, and Colombia), and lowland regions of Amazon Basin-facing Andes in Peru, throughout on white sands. Ten species are recognized, including four established species: *B. antoniifolia* Progel, *B. aquatica* Ducke, *B. minor* N. E. Br. (including *B. cinchonoides* Gleason & Standl.), and *B. superba* M. R. Schomb. ex Progel. Six species are newly described: *B. excelsa* J. R. Grant (Colombia), *B. magnifica* J. R. Grant (Brazil), *B. nobilis* J. R. Grant (Colombia), *B. pulchra* Ricketson, J. R. Grant & Liesner (Peru), *B. spectabilis* J. R. Grant (Guyana), and *B. venusta* J. R. Grant (Brazil).

Key words: Antonieae, *Bonyunia*, IUCN Red List, Loganiaceae, Neotropics, South America.

The Loganiaceae includes the formerly segregate families Antonieae, Gardneriaceae, Geniostomataceae, Spigeliaceae, and Strychnaceae, and comprises 13 genera: *Antonia* Pohl, *Bonyunia* M. R. Schomb. ex Progel, *Gardneria* Wall., *Geniostoma* J. R. Forst. & G. Forst., *Labordia* Gaudich., *Logania* R. Br., *Mitrasacme* Labill., *Mitreola* L., *Neuburgia* Blume, *Norrisia* Gardner, *Spigelia* L., *Strychnos* L., and *Usteria* Willd. (Bremer & Struwe, 1992; Struwe et al., 1994, 1998; Backlund et al., 2000; Angiosperm Phylogeny Group, 2003; Struwe & Motley, in press). The genus of interest here, *Bonyunia*, is a Neotropical woody member closely related to *Antonia* (Mori et al., 2002) and *Usteria*, and, based on both morphology and molecular characters, the three genera (perhaps also *Norrisia*) comprise the tribe Antonieae. While *Bonyunia* has been shown to be distinct from related genera (Struwe & Albert, 1997), a preliminary screening at the Université de Neuchâtel of a series of adequate herbarium samples was unsuccessful in

the amplification of DNA (chloroplast *trnL-F*) from enough taxa to establish a genus-wide phylogeny. *Bonyunia* has essentially lain in obscurity, with the exception of several brief references and a revision nearly 40 years ago (Leeuwenberg, 1969). The accumulation of enough interesting material has finally resulted in the need for a full taxonomic revision.

Bonyunia occurs in generally lowland regions of the Amazon River watershed (Brazil and Bolivia), the Orinoco River watershed (Colombia and Venezuela), tepuis of the Guayana region and outliers (Brazil, Guyana, Venezuela, and Colombia), and lowland regions of Amazon Basin-facing Andes in Peru (Fig. 1). It does not occur on the Brazilian plateau, though it is approached there by *B. antoniifolia* Progel, which has a broad distribution in the Amazonian lowlands along the Amazon River and its tributaries in Brazil and Bolivia. Two other species have somewhat broad distributions that overlap each

¹ I thank the following institutions for the loan of material or data/scans/photos* of specimens in their collections: AAU, B*, BM, BR, COL*, F, FMB, G, GH, HUT*, IAN*, K, M*, MA, MG*, MO, NY, P, R*, RB*, S, SP*, U, UC, US, USZ*, W*, WAG, and Z. Information on collections, some of which were not requested on loan, was provided by: Ione Bemerguy (MG), Rodrigo Bernal (COL), José Enrique Castillo (FMB), Inês Cordeiro (SP), Andrea Ferreira da Costa (R), Hans-Joachim Esser (M), Rafaela Forzza (RB), Humberto Mendoza (FMB), Martin Nickol (KIEL), Bruno Rezende (RB), Jon Ricketson (MO), Eric Rodriguez (HUT), Franz Schuhwerk (M), Bruno Wallnöfer (W), and the Tropicos database of the Missouri Botanical Garden (MO). Library research was carried out at the Conservatoire et Jardins botaniques de la Ville de Genève, Switzerland. Bobbi Angell skillfully prepared the illustrations. The geographic information system-based distribution map was prepared by Phillip Miami, Rutgers University (CHRB), and modified by Yves Maumary (Neuchâtel). Neil Villard (Neuchâtel) prepared the photographs of seeds and herbarium specimens. Lena Struwe (CHRB) edited the manuscript, and Mary Endress (Z) provided relevant literature.

² Laboratoire de botanique évolutive, Institut de Biologie, Université de Neuchâtel, rue Émile-Argand 11, Case Postale 158, 2009 Neuchâtel, Switzerland. jason.grant@unine.ch.

doi: 10.3417/2006135

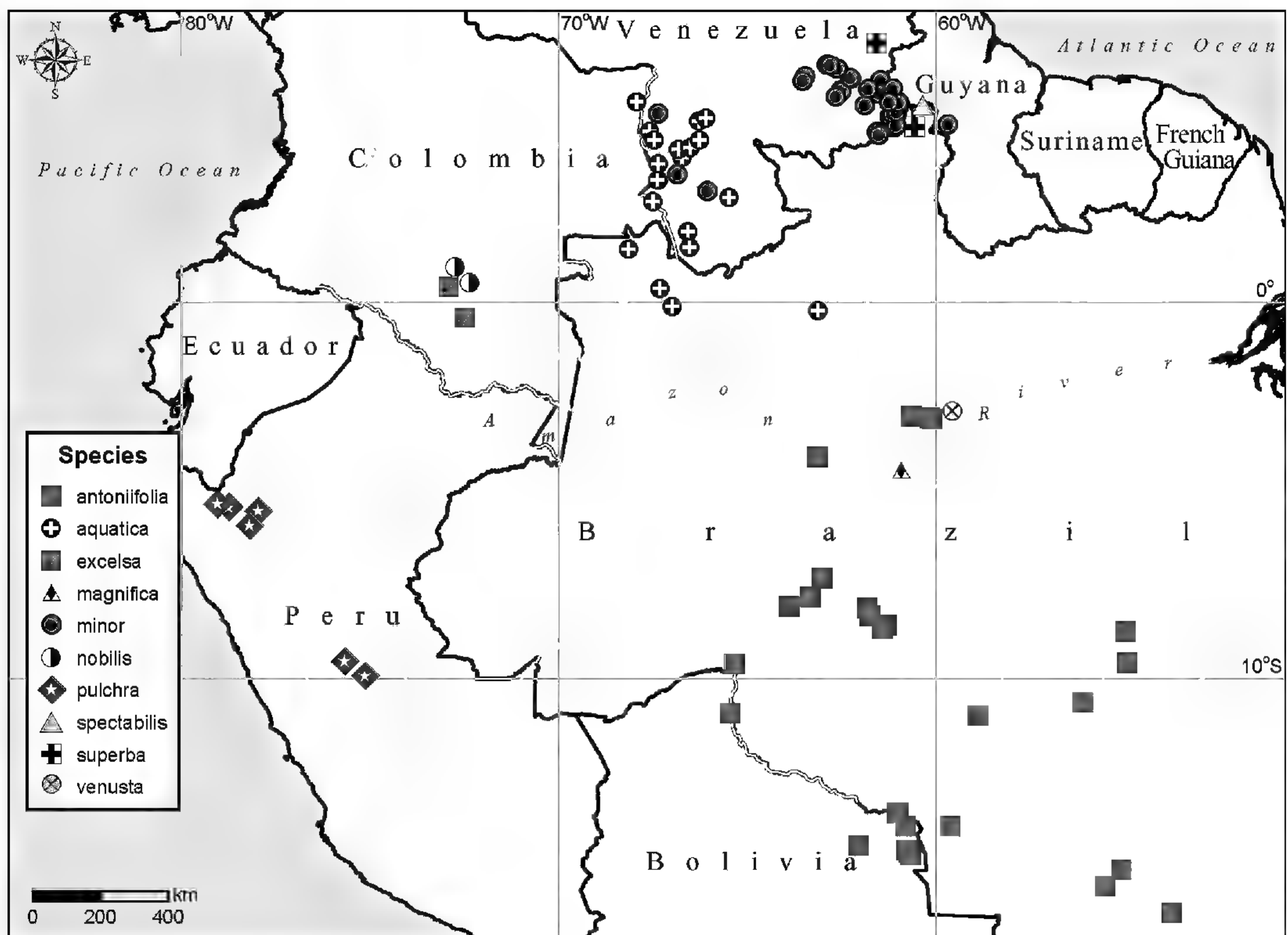

Figure 1. Map of the distribution of *Bonyunia* in South America.

other: *B. aquatica* Ducke and *B. minor* N. E. Br. *Bonyunia aquatica* ranges principally along the lowlands of the Orinoco River watershed in Colombia and Venezuela but also extends to the Rio Negro in Brazil. *Bonyunia minor* occupies higher-elevation savanna and tepui habitats of the Guayana region in Venezuela and Guyana. The remaining seven species are known from only one to 10 collections, and therefore their distribution is poorly known. These mostly occur in areas of high endemism (Sierra de Chiribiquete and Mount Roraima of the Guayana region, and the Andes) and are probably narrow endemics. Both *B. spectabilis* J. R. Grant and *B. superba* M. R. Schomb. ex Progel occur on Mount Roraima along the Venezuela–Guyana border in the Guayana region and are possibly partly sympatric with *B. minor*. *Bonyunia excelsa* J. R. Grant and *B. nobilis* J. R. Grant are known from isolated outliers of the Guayana region in Colombia on the Sierra de Chiribiquete, and *B. magnifica* J. R. Grant and *B. venusta* J. R. Grant occur in the Amazon lowlands of Brazil. *Bonyunia pulchra* Ricketson, J. R. Grant & Liesner occurs in low-elevation areas of Amazon-facing low-Andean slopes in Peru.

With its 10 species (Appendix 1), *Bonyunia* has an overall distribution that nearly mirrors that of two genera of the Gentianaceae: *Potalia* Aubl. with nine species (Struwe & Albert, 2004) and *Tachia* Aubl. with 13 species (Maguire & Weaver, 1975; Peters et al., 2004; Struwe et al., 2005). While each of these three genera is generally composed of narrow endemics, each also has one species that is generally wide ranging in lowland Amazonia: *B. antoniifolia*, *P. resinifera* Mart., and *T. occidentalis* Maguire & Weaver. Further comparative phylogeographic and geographic studies on these groups are currently under investigation (Grant & Struwe, in prep.). In contrast to these less speciose genera, *Macrocarpaea* (Gentianaceae), with more than 100 species, has recently been shown to occur almost exclusively in mountainous regions of the Neotropics (Struwe et al., 2009).

Richard Schomburgk named *Bonyunia* in honor of his friend George Reginald Bonyun, M.D. (ca. 1811–1853), a medical doctor of Georgetown Guyana (Schomburgk, 1848). In the same manner in which his brother Robert Schomburgk reported on his geographic surveys to the governor of British Guiana, Sir Henry Light, George Bonyun was commissioned by Light to report on the general health of immigrants

and the conditions in rural hospitals (Bonyun, 1848: 22). Bonyun also published several articles on the ethnobotanical use of plants, including the Demerara pinkroot, *Spigelia anthelmia* L. (Loganiaceae) (Bonyun, 1844).

MATERIALS AND METHODS

All available types and specimens of *Bonyunia* from herbaria with large Neotropical collections were examined on loan or via data/scans/photos* of specimens including AAU, B*, BM, BR, COL*, F, FMB, G, GH, HUT*, K, M, MA, MO, NY, P, R*, RB*, S, SP*, U, UC, US, USZ*, W*, WAG, and Z. Additional information was also extracted from Tropicos, the online database of the Missouri Botanical Garden (<<http://www.tropicos.org>>). One hundred seventy-eight collections were examined, often with multiple duplicates, for a total of 402 sheets, which is a nearly fourfold increase of collections since the revision by Leeuwenberg (1969).

TAXONOMIC HISTORY

Bonyunia was proposed as a monotypic genus in the Loganiaceae (Schomburgk, 1848). However, despite providing locality information, there was no description, diagnosis, or illustration, rendering it a nomen nudum and invalid. Valid establishment of the genus and species was only effected 20 years later by Progel (1868) in his treatment of the Loganiaceae in Martius' *Flora Brasiliensis*. Typification remained problematic, however, because although the genus had been originally proposed by Schomburgk as monotypic (for *B. superba* M. R. Schomb. from Venezuela), Progel added a second species that inadvertently resulted in a simultaneous publication date for both species, *B. superba* M. R. Schomb. ex Progel, and *B. antoniifolia* from Brazil, which was published in the *Mantissa* (addendum or supplement). Nevertheless, Leeuwenberg (1969) effectively lectotypified the genus on *B. superba*, whereby Schomburgk's original intent of the genus was preserved.

After those first two species, three more were eventually added to the genus: *Bonyunia minor* from Guyana (Brown, 1901), *B. cinchonoides* Gleason & Standl. from Venezuela (Gleason, 1931), and *B. aquatica* from Brazil (Ducke, 1935). Leeuwenberg (1969) revised *Bonyunia* and accepted four species: *B. antoniifolia*, *B. aquatica*, *B. minor* (placing *B. cinchonoides* in synonymy under *B. minor*), and *B. superba*. While this is the only revision of *Bonyunia*, Berry, in the *Flora of the Venezuelan Guayana* (2001), provided a brief synopsis largely based on Leeuwenberg's work. Until now, these two pieces of literature

have remained the primary sources of information on *Bonyunia*.

MORPHOLOGY

Bonyunia is characterized by a white to yellowish white corolla at anthesis that turns pink, red, to purple at maturity (Fig. 2A); thin and double-winged seeds (Fig. 2C); leaves that are opposite, entire, with many variations in shape (Figs. 2B, 3, 5); and 5-merous flowers with a campanulate calyx (Figs. 4, 5). While having only 10 species, *Bonyunia* exhibits a rather extraordinary breadth of morphological diversity, especially in habit, leaves, calyces, and seeds.

HABIT

Bonyunia is comprised of lowland rainforest riverside trees (*B. aquatica*), lowland rainforest terra firme canopy-level trees (*B. magnifica*, *B. venusta*), shrubs and trees of grasslands and open savanna (*B. antoniifolia*), savanna-tepui shrubs (*B. minor*), tepui-base trees (*B. excelsa*, *B. nobilis*), cloud forest trees (*B. spectabilis*, *B. superba*), and Andean rainforest trees (*B. pulchra*). It occupies a broad range of habitats reflecting its adaptation to the major ecosystems in northwestern South America. Inversely, species have undergone morphological adaptation in habit to these habitats. *Bonyunia antoniifolia* is a 5–9 m tall shrub to tree that occurs in grasslands, fields, or open savanna on terra firme, while *B. aquatica* is a 2–15 m tall lowland rainforest riverside tree, and *B. minor* is a 2–10 m tall savanna-tepui shrub to tree. These three species share their strong hairiness and seed morphology, and they also have a preference for open, sunny localities (river corridors and savannas). The remaining species occur in closed forests and tend to be glabrous and generally decrease in height toward higher elevations: *B. magnifica* and *B. venusta* are 15–20 m tall lowland rainforest terra firme canopy forest-level trees, *B. pulchra* comprise 15–40 m tall Andean rainforest trees, *B. excelsa* and *B. nobilis* are 4–35 m tall tepui-base trees, while *B. spectabilis* and *B. superba* are 1.8–7.6 m tall cloud forest trees.

LEAVES

The leaves of each species of *Bonyunia* have a unique suite of morphological characters that renders leaf morphology very useful in species identification (Figs. 3, 5). The variable and taxonomically useful characters include the overall shape of the leaves (ovate, elliptic, oval, to obovate), the leaf base (attenuate, cuneate, cordate, to rounded), and the leaf

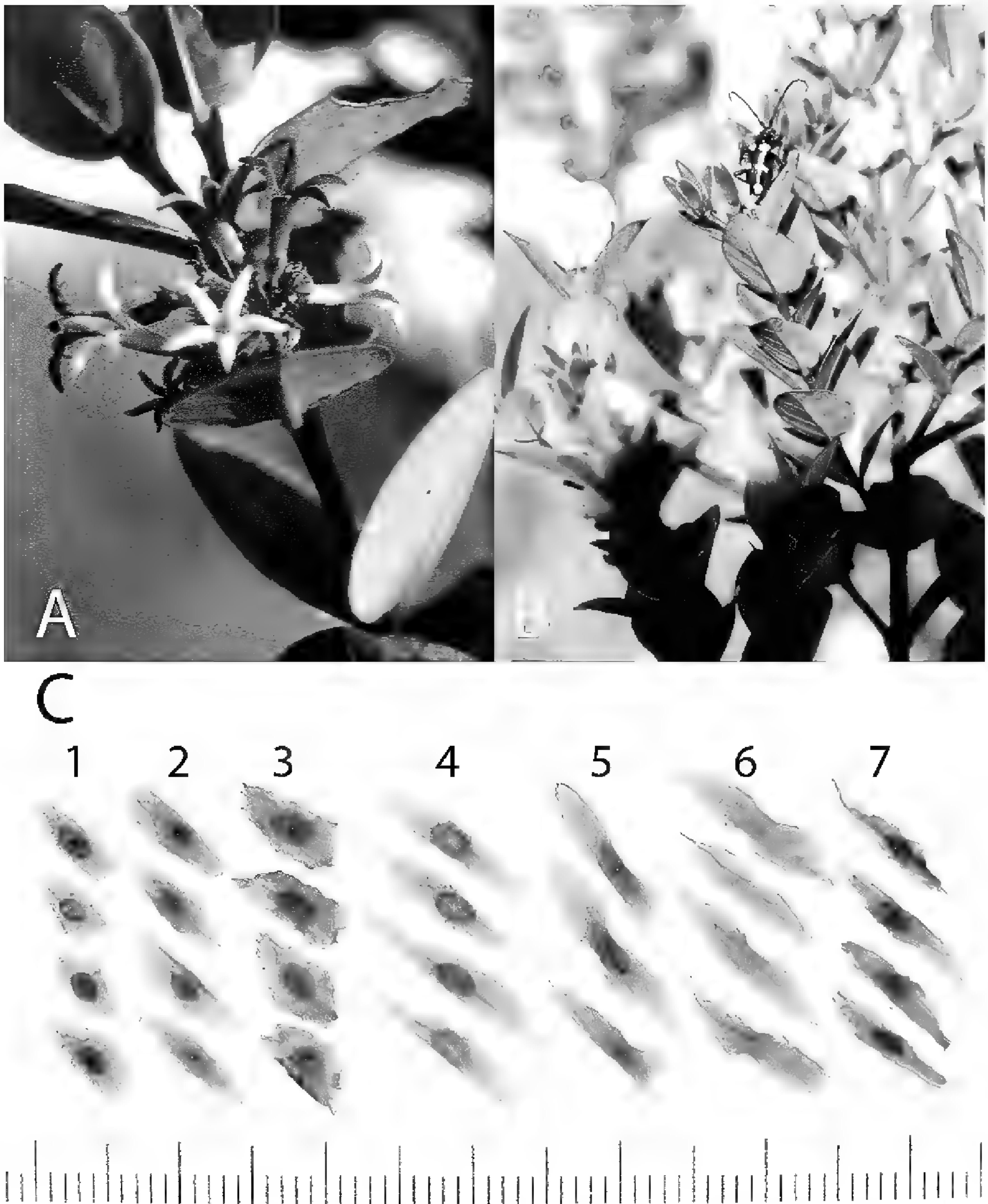

Figure 2. —A. *Bonyunia minor* in flower. Corolla is white to yellowish white at anthesis, yet changes at maturity or perhaps once pollinated to pink, red, or purple. —B. *B. minor* in fruit; notice Cerambycidae insect. —C. Seed morphology of *Bonyunia*. 1. *B. antoniifolia* (Dambros 356 [US]). 2. *B. minor* (Maguire & Wurdack 30525 [WAG]). 3. *B. aquatica* (Ducke 224 [NY]). 4. *B. superba* (Pinkus 270 [US]). 5. *B. magnifica* (Prance et al. 22804 [WAG]). 6. *B. nobilis* (Palacios et al. 2393 [MO]). 7. *B. pulchra* (Wallnöfer 14-41088 [K]). A, B photos by Robin Foster. C photo by Neil Villard.

apex (acuminate, acute, obtuse, rounded, to retuse), in addition to the texture (thin to thick) and indument on the abaxial leaf surface, especially along the midvein and secondary veins (glabrous to densely hispid). The

classification of Leeuwenberg (1969) relied nearly entirely on leaf morphology and is also important in this monograph, although calyx and seed morphology are equally important in this treatment.

STEMS AND INFLORESCENCES

Bonyunia is composed of branched shrubs and trees, and the apex of each branch has an inflorescence composed of a dichasium of paired cymes. The stems of *Bonyunia* are solid and round. In most species, the stems and peduncles are at least sparsely pubescent, though a few species are completely glabrous (*B. magnifica*, *B. minor*, and *B. nobilis*). In several notable cases, the stems are nearly glabrous, or sometimes with only one side pubescent, yet the branches of the inflorescence are contrastingly extremely pubescent, e.g., *B. excelsa*.

FLOWERS

The corolla of *Bonyunia* is white to yellowish white at anthesis and changes at maturity or, perhaps, once pollinated, to pink, red, or purple (Fig. 2A). Nevertheless, the corolla, pistil, and stamens of *Bonyunia* have few taxonomically informative characters. In species with only few flowers available on the herbarium specimens for study, full dissections were not made because the measurements are nearly identical between species and destroying small amounts of precious material was not worthwhile. The outside of the corolla tube and corolla lobes is always appressed strigose, its hairs being shorter than the hairs on the calyx. The inside of the reflexed corolla lobes is glabrous and therefore exposes the color of the corolla (otherwise covered by hairs on the outside).

The shape and indument of the calyx and calyx lobes are among the most important features in species identification (Figs. 4, 5). The calyx indumentum ranges from densely appressed strigose to hispid (in *Bonyunia antoniifolia*, *B. aquatica*, and *B. spectabilis*), hispidulous to glabrous (in *B. pulchra*), glabrous to hispidulous (in *B. venusta* and *B. excelsa*), to glabrous (in *B. magnifica*, *B. minor*, *B. nobilis*, and *B. superba*). Sometimes a few hispid hairs migrate toward the pedicel or peduncle (e.g., in *B. minor*), and sometimes tufts of hairs appear on the apices of the calyx lobes (*B. nobilis*). The overall length of the calyx is rather similar in all species (2–4[–6] mm, including 0.3–1.5 mm calyx lobes), yet one species, *B. superba*, is exceptional in having 5–10 mm calyces, including 2–6 mm calyx lobes. *Bonyunia superba* is also unique in having spatulate-shaped calyx lobes, while all other species have triangular-shaped lobes. The classification presented here is largely based on calyx characters.

FRI ITS AND SEEDS

The pistil and mature fruit of all species of *Bonyunia* are extremely hispid throughout. The fruits are erect and appear to have a rather consistent morphology as ovoid, ellipsoid to obovoid, bivalved, dry dehiscent capsules (Fig. 2B), with each locule containing one to 20 thin, flattened, winged seeds per locule (e.g., two to 40 seeds per capsule). *Bonyunia* and its closely related genus *Antonia* have winged seeds in dry capsules that facilitate wind dispersal (Mori & Brown, 1994).

There is a broad and previously unrecognized range of seed morphology in *Bonyunia* (Fig. 2C). In the absence of a molecular-based phylogenetic hypothesis, the seed characters provide a useful insight into the relationships in the genus. Seven of the 10 species have specimens with mature fruits and seeds: *B. antoniifolia*, *B. aquatica*, *B. magnifica*, *B. minor*, *B. nobilis*, *B. pulchra*, and *B. superba* (mature seeds are missing for only *B. excelsa*, *B. spectabilis*, and *B. venusta*). After examination of seeds of several capsules on multiple specimens per species, seed size appears to be consistent within species. Based on seed morphology, these species can be divided into two groups based on morphology and color. Group I (Fig. 2C, 1–4) is comprised of five species that have rather thin, flattened seeds with a large, prominent, brown seed body and tan-colored wings: *B. antoniifolia*, *B. aquatica*, *B. minor*, and *B. superba*; the seeds available from *B. spectabilis* are immature, but the species clearly belongs here. Group II (Fig. 2C, 5–7) comprises three species with a more three-dimensional aspect with slightly curled seed wings, has a less prominent difference in color between the bodies and wings, and is rather orangish in color: *B. magnifica*, *B. nobilis*, and *B. pulchra*. Despite disjunct localities, the unique shared seed morphological characters of *B. magnifica* (Amazonian Brazil) and *B. nobilis* (Colombia) support their close relationship, as seen in their similar leaf morphologies. Seeds are not available for *B. excelsa* or *B. venusta*, but, based on general morphology, they probably belong to group I. To summarize, *Bonyunia* can be divided into two groups based on seed morphology:

Group I: *B. antoniifolia*, *B. aquatica*, *B. minor*, *B. spectabilis*, *B. superba* (Amazon River basin of Brazil and Bolivia, the Orinoco River basin of Colombia and Venezuela, and the Guayana region: Guyana, Venezuela)

Group II: *B. magnifica*, *B. nobilis* (Brazil, Colombia), *B. pulchra* (lowland Andes of Peru)

Unknown: *B. excelsa*, *B. venusta* (Colombia, Brazil)

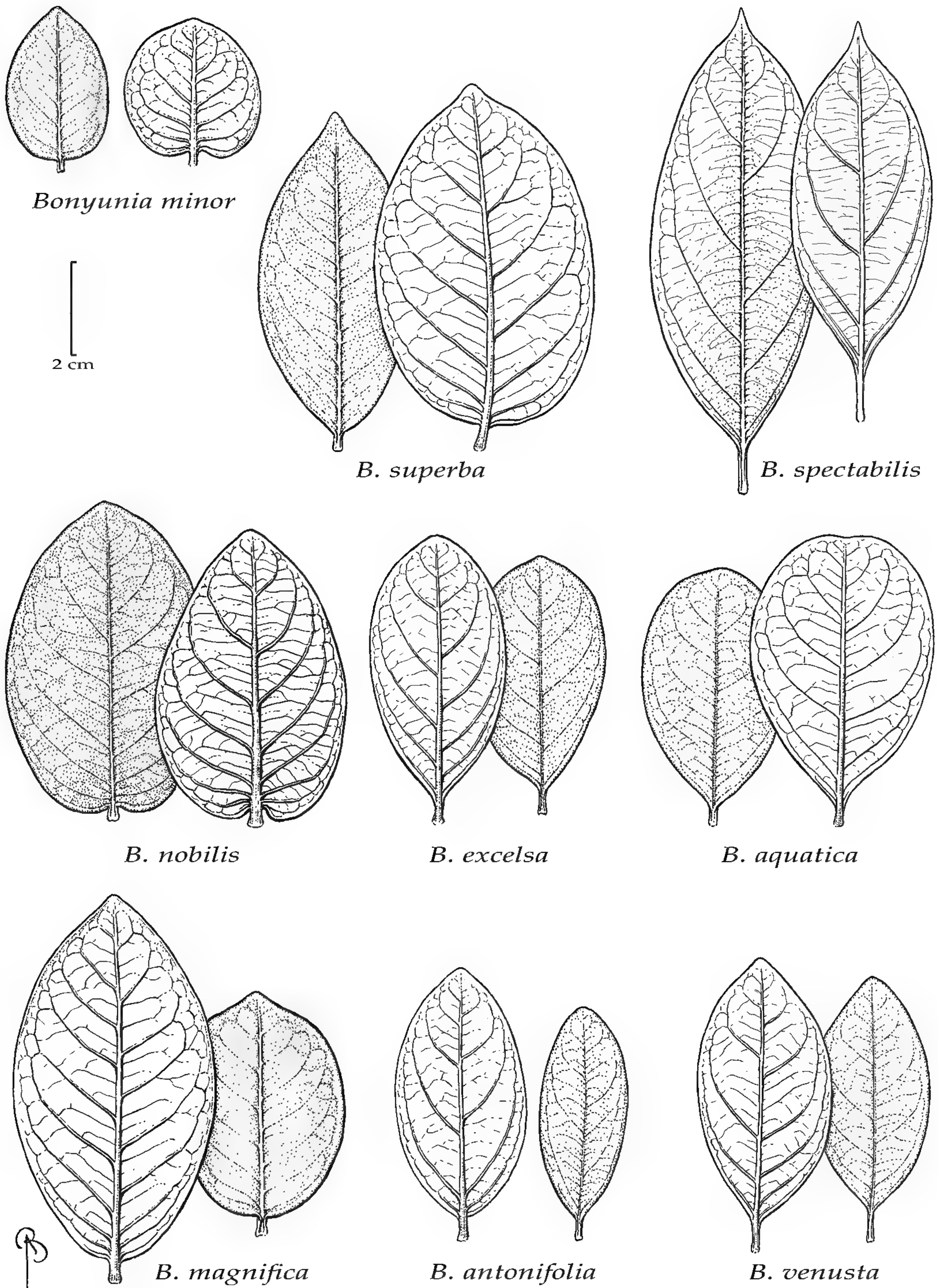

Figure 3. Leaf morphology of *Bonyunia*. *Bonyunia antonifolia* (drawn from Prance 5758 [S]), *B. aquatica* (drawn from Huber 1932 [NY]), *B. excelsa* (drawn from Restrepo 387 [MO]), *B. magnifica* (drawn from Prance et al. 22804 [NY]), *B. minor* (drawn from Maguire 40482 [NY], left, and Maguire 46143 [NY], right), *B. nobilis* (drawn from Palacios 2393 [MO]), *B. spectabilis* (drawn from Hahn & Gopaul 5420 [F]), *B. superba* (drawn from Schomburgk 613 [BM]), and *B. venusta* (drawn from Ribeiro et al. 1103 [NY]).

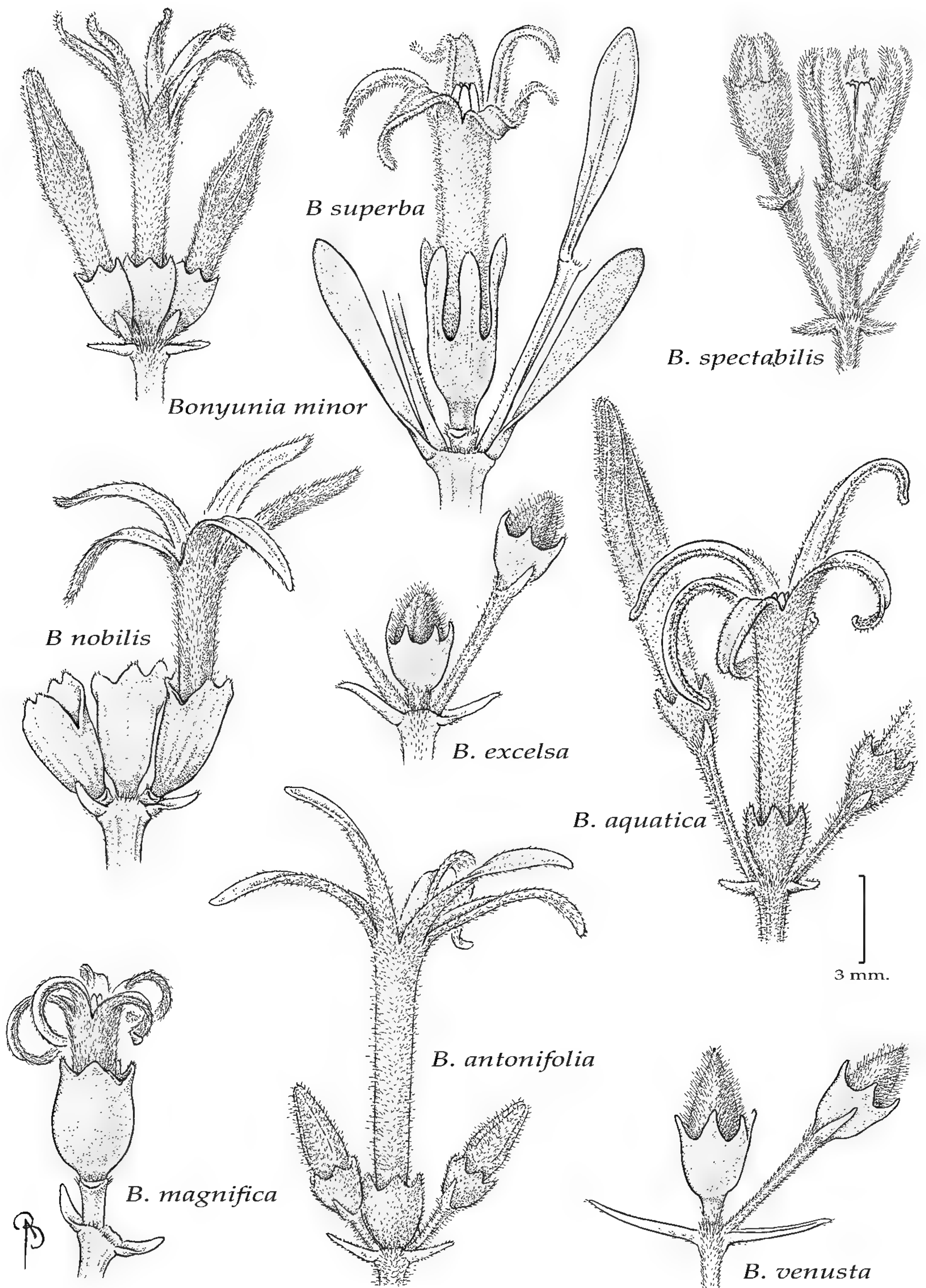
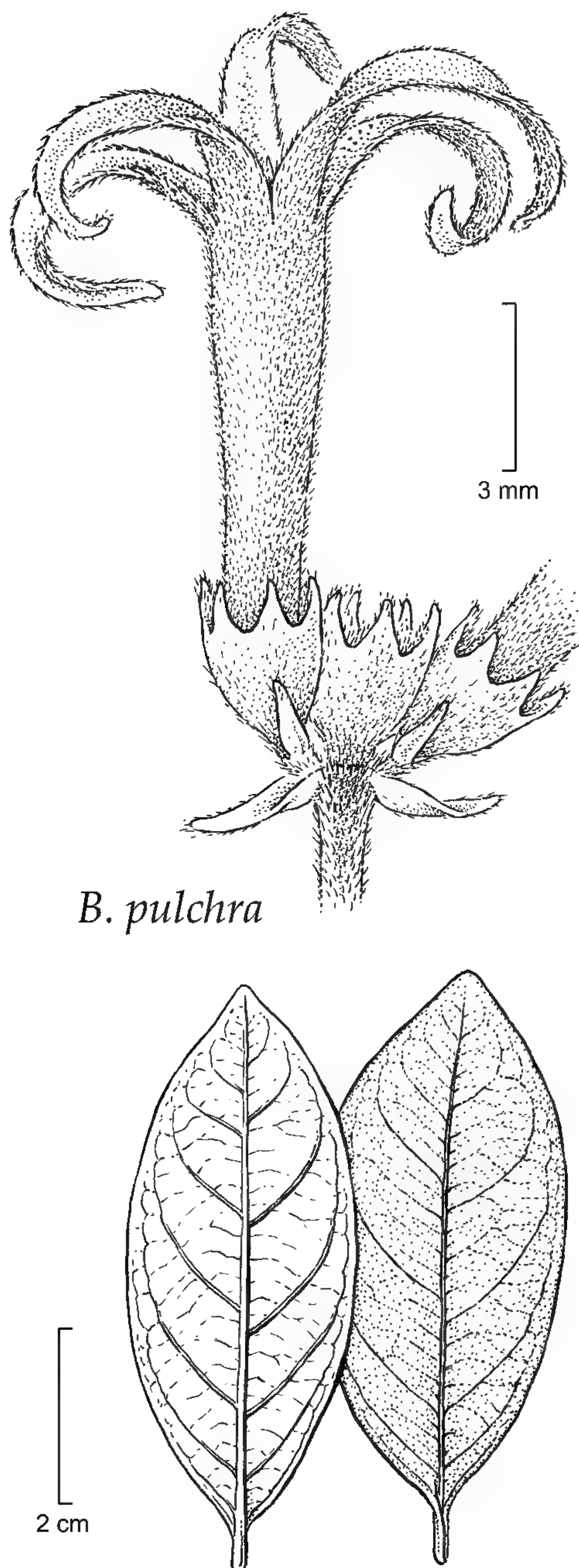

Figure 4. Floral morphology of *Bonyunia* demonstrating morphological differences in the shape and indument of the calyx. *Bonyunia antoniiifolia* (drawn from Ferreira 5688 [MO]), *B. aquatica* (drawn from Foldats 9423 [NY]), *B. excelsa* (drawn from Restrepo 387 [MO]), *B. magnaifica* (drawn from Prance et al. 22804 [NY]), *B. minor* (drawn from Maguire 46143A [NY]), *B. nobilis* (drawn from Mendoza 9558 [FMB]), *B. spectabilis* (drawn from Hahn & Gopaul 5420 [US]), *B. superba* (drawn from Schomburgk 613 [BM]), and *B. venusta* (drawn from Ribeiro et al. 1103 [NY]).



B. pulchra

Figure 5. Floral and leaf morphology of *Bonyunia pulchra* (drawn from Rojas 478 [F, MO] from Peru).

TAXONOMIC TREATMENT

Bonyunia M. R. Schomb. ex Progel, Fl. Bras. (Martius) 6(1): 267, t. 72. 1868. TYPE: *Bon-*

KEY TO THE SPECIES OF *BONYUNIA*

- 1a. Calyx densely pubescent throughout (appressed strigose to hispid).
 2a. Leaves consistently broadly to narrowly obovate; lowlands along the Orinoco River and its tributaries in Venezuela and Colombia, and along the upper Rio Negro in Brazil 2. *B. aquatica*

yunia superba M. R. Schomb. ex Progel, Fl. Bras. (Martius) 6(1): 267, tab. 72. 1868 (lectotype, designated by Leeuwenberg, 1969: 158).

Branched shrubs or trees, 2–40 m tall, glabrous to hispid; stems round, solid. Leaves opposite, short to long-petiolate; blades simple, pinnately veined, thin and membranous to thick and coriaceous, margins entire, variously shaped (ovate, oval, elliptic, orbicular, obelliptic, obovate, lanceolate, to oblanceolate). Inflorescence a terminal dichasium of paired cymes, 3 to 7 flowers per cyme; bracts (organs on peduncles that subtend inflorescence branches, or flowers) leafy, often similar to the leaves, sessile to short-petiolate; bracteoles (organs on pedicels that subtend individual flowers) triangular to spatulate. Flowers sessile to pedicellate, 5-merous (calyx, corolla, and stamens), bracteolate; calyx green, campanulate to urceolate, glabrous to hispid, ecarinate to slightly keeled, calyx lobes triangular, spatulate to obovate, apices acute to acuminate; corolla white to yellowish white at anthesis, turning pink, red, to purple at maturity, trumpet-shaped with a long fused tube to 2/3 of the total length, and 5 reflexed linear-long lobes; outside of the corolla tube and corolla lobes densely pubescent (appressed strigose), inside of the reflexed corolla lobes glabrous and therefore exposing the corolla color (otherwise obscured); stamens 5, included, equal, one on each of the corolla lobes inserted just below sinuses; filaments adnate to the corolla, the free portion less than 0.5 mm; anthers basifixed, linear-oblong, sagittate at the base; pistil included within the corolla tube, much shorter than the stamens, hispid; ovary superior, ovoid, placentation axile; style straight; stigma bilobed, the lobes acute, acuminate to spatulate; style and stigma deciduous in fruit. Capsules septicidally dehiscent, ellipsoid to obovoid, pubescent, erect, tan to brown, surface hispid, bilocular, 1 to 20 seeds per locule (e.g., 2 to 40 seeds per capsule); seeds oblong, flattened, yet overall concave to one side, winged all around; seed body ellipsoid, brown; seed wings straw-gold to dark orange, reticulate.

Species are based on discrete suites of morphological characters, especially habit and leaf, calyx, and seed morphology. Some unique characters include indumentum (hispid in *Bonyunia antoniifolia*, *B. aquatica*, and *B. spectabilis* vs. glabrous in all other species), calyx shape (urceolate in *B. magnifica* vs. campanulate in all other species), and calyx lobe shape (obovate in *B. superba* vs. triangular in all other species).

- 2b. Leaves elliptic or ovate.
 - 3a. Leaves short-petiolate (petiole 2–4 mm), elliptic to ovate, rarely obovate, base cuneate to rounded, apex obtuse to rounded; stems and peduncles hispid; calyx appressed strigose to hispid; widespread in lowlands along the Amazon River and its major tributaries in Brazil and Bolivia 1. *B. antoniifolia*
 - 3b. Leaves long-petiolate (petiole 5–10 mm), elliptic to nearly narrowly lanceolate, base long attenuate to cuneate, apex acuminate to acute; stems glabrous, peduncles hispid; calyx densely appressed strigose to hispid; Mount Roraima, Guyana 8. *B. spectabilis*
- 1b. Calyx glabrous or nearly so, tufts of hispid hairs may occur on calyx lobe apices, or hairs may approach the calyx from the pedicel beneath, or sparse hairs may occur, especially in Peruvian material.
 - 4a. Calyx lobes spatulate to obovate, equaling to much exceeding the length of the calyx tube; bracteoles prominent, spatulate to obovate, equaling to exceeding the calyx in length; Venezuela and Guyana 9. *B. superba*
 - 4b. Calyx lobes triangular, shorter than the length of the calyx tube; bracteoles inconspicuous, triangular to linear-triangular, shorter than the calyx.
 - 5a. Leaves thick-coriaceous; leaf bases rounded to cordate (seldom cuneate); pedicels glabrous to glabrescent throughout to rarely with tufts of hairs at the uppermost part under the calyx; calyx lobes acute.
 - 6a. Leaves small, up to 4.5(–8.6) cm long, adaxial surface even in color; seed body brown, wings straw-gold; savanna shrubs or forest trees from 2–10 m tall at higher-elevation savanna and tepui habitats of Venezuela and Guyana 5. *B. minor*
 - 6b. Leaves larger, up to 10 cm long, adaxial surface minutely etched revealing a lighter color with small alphabet/hieroglyphic-shaped marks; seed body and wings dark orange; forest trees 7–20 m tall.
 - 7a. Calyx narrowly campanulate, glabrous, striate, with tufts of hairs on calyx lobe apices; Sierra de Chiribiquete in Colombia 6. *B. nobilis*
 - 7b. Calyx urceolate to campanulate, calyx lobe apices glabrous; terra firme of the Amazon lowlands of Brazil 4. *B. magnifica*
 - 5b. Leaves thin coriaceous; leaf bases cuneate; pedicels pubescent throughout; calyx lobes acuminate to acute.
 - 8a. Secondary flowers sessile to subsessile; Peru 7. *B. pulchra*
 - 8b. Secondary flowers pedicellate; Colombia or Brazil.
 - 9a. Stems glabrous, to hispid along one side, but branches of the inflorescence always hispid; leaves with 5 to 7 pairs of nearly parallel to arching secondary veins; Sierra de Chiribiquete in Colombia 3. *B. excelsa*
 - 9b. Stems and branches of the inflorescence equally lightly hispid; leaves with 3 to 6 pairs of arching secondary veins; Amazon lowlands of Brazil 10. *B. venusta*

1. *Bonyunia antoniifolia* Progel, Fl. Bras. (Martius) 6(1): 288. 1868. TYPE: Brazil. Mato Grosso: “In saxosis S. da Chapada” [Santa Ana da Chapada, near Cuiabá], Sep. 1827, *L. Riedel 1149* (holotype, BR!; isotypes, LE not seen, MO!, NY!). Figures 1, 2C, 3, 4, 6A, B.

Branched shrub to tree to 5–9 m tall, densely hispid throughout, glabrous only on adaxial leaf surfaces; trunk to 10–30 cm diam.; bark thick fissured to corky. Leaves oval, elliptic, to ovate, rarely obovate, short-petiolate, 3.2–7.2 cm, petiole 2–4 mm; blades 3.5–7.4 × 1.8–5 cm, thin-coriaceous, darker adaxially, slightly glossy adaxially and more opaque abaxially, adaxial surface smooth with some slightly impressed veins, abaxial surface with slightly raised secondary veins; base cuneate to rounded; apex obtuse to rounded. Inflorescence 2–8 cm; branches 1–6 cm; bracts oval, ovate, to obovate, short-petiolate, 4–20 × 2–15 mm; base cuneate to rounded; apex obtuse to rounded; bract petioles 1–3 mm; primary flower sessile to subsessile, secondary flowers pedicellate; pedicels 1–5 mm; bracteoles triangular, 0.75–3 × 0.5–1 mm. Calyx campanulate, 2–3 × 1.5–2 mm, appressed strigose to hispid, ecarinate; calyx lobes triangular, 0.3–1 × 1.5–2 mm, apex acute; corolla 17–30 mm; tube 8–11 × 1–1.5 mm; lobes 7–9 × 0.75–2 mm, apex rounded to obtuse; stamens includ-

ed; filaments less than 0.5 mm; anthers 1.8–2 × 0.3–0.5 mm; pistil ca. 8 mm; ovary ovate, orbicular to obovate, 1–1.5 × ca. 1 mm; style 6–7 × 0.3–0.5 mm; stigma bilobed, each lobe spatulate, 0.50–0.75 × ca. 0.5 mm. Capsules ellipsoid to ovoid, 12–16 × 5–8 mm (excluding style base), tan, 4 to 12 seeds per locule (e.g., 8 to 24 seeds per fruit); seeds 4.5–7.5 × 2–2.75 mm, seed body brown, seed wings straw-gold, reticulate.

Morphology and similarities. *Bonyunia antoniifolia* is distinctive in being densely hispid throughout (as in *B. aquatica* and, to a lesser extent, *B. spectabilis*) and having similar-sized elliptic to ovate leaves with a cuneate to rounded base and apex. It appears to be most similar to *B. aquatica*, *B. minor*, *B. superba*, and *B. spectabilis*. These five species share flattened seeds with a large, prominent, brown seed body and tan-colored wings.

Distribution and habitat. *Bonyunia antoniifolia* occurs in grasslands, fields, or open savanna on terra firme, throughout on white sandy to stony soils. It has a broad distribution in the Amazon River basin and its tributaries in Brazil and Bolivia (Fig. 1) at elevations of 80–800 m. It has the broadest distribution of all species in the genus and a rather consistent morphology across its range.

IUCN Red List category. *Bonyunia antoniifolia* has a broad distribution in Brazil and Bolivia and has

been collected in formally protected areas such as the Parque Nacional Noel Kempff Mercado (Bolivia). It is assigned a preliminary IUCN status of Least Concern (LC) as set forth in the IUCN Red List Categories and Criteria (IUCN, 2001).

Etymology. The epithet is taken from *Antonia* and the Latin “folium,” named for the resemblance of its leaves to that of the genus *Antonia* (Loganiaceae).

Typification. The disparity of the type locality as published in the protologue of *Bonyunia antoniifolia* and printed on the herbarium label of its type (*L. Riedel 1149*) is resolved here. The protologue of Progel identifies the collection site as “Serra da Chapada, Prov. Minarum,” and accordingly, most references to *Bonyunia* have listed the type or at least *B. antoniifolia* as coming from Minas Gerais, Brazil (e.g., Ducke, 1935; Berry, 2001). However, the herbarium label reads “In saxosis S. da Chapada. Sept 1827. Brazilia. Riedel Nro. 1149 Rubiaceae.” In the list of itineraries for *Flora Brasiliensis*, it is noted that Riedel did not collect in Minas Gerais in September 1827, but rather in Mato Grosso: “Rio S. Lourenço ad Cuyabá (I.–IX. 27), Serra Chapada (V., VI.)” (Urban, 1906: 91). The collection site of Serra da Chapada probably refers to Santa Ana da Chapada, which is near Cuiabá in Mato Grosso. This fits in perfectly well with the distribution of *B. antoniifolia* as mapped here. *Bonyunia* does not occur in Minas Gerais. A sheet of *Riedel 1149* should be at R since a full set of his material was deposited there; however, a recent search at R has uncovered a catalogue indicating that Riedel numbers 1147 to 1182 were never sent (A. Costa, pers. comm.). The MO and NY sheets are identified here for the first time as isotypes of *B. antoniifolia*. Both match the material on the BR sheet, but the labels are completely different. Ludwig Riedel, the collector of the type, deposited the main set of his collections at St. Petersburg, Russia (LE), and the second in Rio de Janeiro. The MO and NY sheets were distributed from LE, and the labels are standard-issue typeset labels in Russian, with only the following handwritten information to identify the specimen: “Indetercei, No 1149, Brasilia, Riedel.”

Specimens examined. BOLIVIA. **Beni:** Itenez, Serranía San Simon, *R. Quevedo et al. 973* (G, MO, NY, USZ not seen); Vaca Diez, entre Guayaramerin y Río Yata, carr. a Riberalta, 14 km SO de Guayaramerin, *L. Vargas et al. 830* (WAG). **Santa Cruz:** Catarata del Encanto, Huanchaca, La Meceta, *R. Guillén 2513* (G, MA, MO, NY, USZ not seen); Velasco, Camp. El Refugio, *R. Guillén & G. Salvatierra 2315* (MA, NY, USZ not seen); Parque Nacional Noel Kempff Mercado, Los Fierros, La Meseta, *R. Guillén et al. 4161* (F, MA, NY, USZ not seen); Velasco, Parque Nacional Noel Kempff Mercado, *E. Gutiérrez et al. 1323* (G, MO, NY, USZ not seen), *T. Killeen 2749* (NY); Nuflo de Chavez, Mesetea de Caparuch, *E. Gutiérrez et al. 1444* (MO, USZ not seen);

Velasco, Parque Nacional Noel Kempff Mercado, Serranía de Caparuch, 750 m, *T. Killeen et al. 6501* (F, MO, NY, USZ not seen); Velasco, Parque Nacional Noel Kempff Mercado, Serranía de Caparuch, a 20 km SE del Camp. Los Fierros, *T. Killeen et al. 7080* (MO, NY, USZ not seen); Velasco, Parque Nacional Noel Kempff Mercado, Serranía S y NE de la pista Noel Kempff Mercado, *B. Mostacedo et al. 1815* (G, NY, USZ not seen); Parque Nacional Noel Kempff Mercado, Serranía S y NE de la posta Noel Kempff Mercado, *B. Mostacedo et al. 1861* (G, MO, NY, USZ not seen); Velasco, Est. Flor de Oro, margen del Río Iténez (Guapaoré), 30 km N Serranía de Huanchaca, ca. 85 km E Río Paragua, *M. Peña & R. B. Foster 170* (NY). BRAZIL. s. loc., 10°37'S, 56°06'W, *B. Pena 2005* (MG not seen, RB). **Amazonas:** Rio Negro infer., Bahia Boiassú, Camp Amelia, *A. Ducke 379* (S), *A. Ducke 680* (F, MG not seen, MO, NY, UC, US); Manaus, [80 m], *A. Ducke 738* (F), *A. Ducke 5738* (S), *A. Ducke 11184* (BM, G, RB, S, U), *A. Ducke 11534* (G), *A. Ducke 12197* (BM, G, P, US); Coary, campinas, *A. Ducke 12384* (BM, G, RB, US); Novo Aripuanã, BR 230, 150 km al. L de Humaitá e 30 km para o S na rodovia do Estanho, *C. A. C. Ferreira 5603* (MO, NY, WAG); Humaitá Fazenda Paraíso dos Campos, *A. Janssen 640* (M); Humaitá, Fazenda Arlindo Marmentini, *Janssen & Gemtchujnicov 306* (M); Humaitá, Campos at Km 15 on rd. to Manaus, *K. Kubitzki & H. H. Poppendieck 79-47* (MG not seen, NY); Rd. Porto Velho–Humaitá, Km 75, *E. Lleras et al. P19452* (U, WAG); Rio Negro, margem direita, 50 km acima de Manaus, Campo Amélia (Faz Belo Horizonte), *B. Nelson et al. 1388* (MO, WAG); Fortaleza Savanna, Río Puciarí trib. Río Ituxi, *G. T. Prance et al. 13796* (K, MG not seen, MO, NY, RB, U, US, WAG); Campo Amélia (Faz. Belo Horizonte), entre ig. Acajatuba e margem direita do rio Negro, *G. T. Prance et al. 30033* (MO, NY, WAG); Manaus, campina da Ponta Negra, *W. Rodrigues et al. 8547* (US); Humaitá, estrada Humaitá–Porto Velho, Km 38, *L. O. A. Teixeira et al. 266* (NY, WAG); Humaitá, estrada Humaitá–Jacarecanga, Km 150, *L. O. A. Teixeira et al. 1268* (MG not seen, MO, NY, RB, US, WAG); rodovia do Estanho, margem da rodovia 150 km de Humaitá, *G. Vieira et al. 149* (K, NY, US, WAG). **Mato Grosso:** Vale do Cuaporé, *B. L. Amaral 44* (RB); Castanheira, *T. B. Cavalcanti et al. 2377* (K); Guiratinga, Morro da Arnica, *L. A. Dambrós 356* (US); Proc. Mpio. Chapada dos Guimarães, *J. E. de Paula 1907* (Z); Novo Aripuanã, rodovia do Estanho a 120 km da Transamazônica, *C. A. C. Ferreira 5688* (MO, NY, WAG); Cuiabá, MT. Río Caxipozinho, prox. a Cachoeira Véu de Noiva, *C. A. C. Ferreira 6540* (MO, NY, WAG); Entre, *J. G. Kuhlmann 2233* (SP); Colider, estrada Santarém–Cuiabá, BR 163, Km 762, Serra do Cachimbo a 30 km da cidade de Guarantã, *M. N. Silva et al. 28* (MO, NY, WAG). **Pará:** Itaituba, estrada Santarém–Cuiabá, BR 163, Km 877, Serra do Cachimbo, *L. Amaral et al. 112495* (NY). **Rondônia:** basin of Rio Madeiro, Km 215–216 Madeira–Mamorá railroad near Abuna, *G. T. Prance et al. 5758* (COL, F, GH, K, MG not seen, NY, R, S, U, US, Z).

2. *Bonyunia aquatica* Ducke, Arq. Inst. Biol. Veg. 1: 211. 1935. TYPE: Brazil. Amazonas: “frequens in ripis profunde et permanentemente inundates fluminis Curicuriary inferioris (affluentis Río Negro superioris, civitate Amazonas),” 21 Dec. 1931, *A. Ducke 23760* (holotype, RB!; isotypes, G!, K!, P!, RB [2]!, S!, U!, US!). Figures 1, 2C, 3, 4, 6C, D.

Branched shrub to tree to 2–8(–15) m tall, densely hispid throughout especially on the midvein of the undersides of leaves, petioles, peduncles, inflorescences, calyces, and corollas (glabrous only on adaxial leaf surfaces). Leaves broadly obovate to narrowly obelliptic, short-petiolate, (2.5–)5–7(–9) cm, petiole 2–6 mm; blades (2.3–)5–7(–8.6) × (1.8–)3–5.2 cm, thin-coriaceous, darker adaxially, lighter abaxially, slightly glossy adaxially and more opaque abaxially, adaxial surface smooth with some slightly impressed veins, abaxial surface with slightly raised secondary veins; base aequilateral; apex rounded to retuse. Inflorescence 3–9 cm; branches 2.5–6 cm; bracts obovate to obelliptic, sessile to short-petiolate, (3–)6–28 × (1–)3–12 mm; base aequilateral; apex rounded to retuse; bract petioles 0–2 mm; primary flower sessile to subsessile, secondary flowers pedicellate; pedicels 0.5–3 mm; bracteoles triangular, 0.75–1.75 × 0.5–0.75 mm. Calyx campanulate, 2.5–3.5 × 1.5–2.5 mm, appressed strigose to hispid, ecarinate; calyx lobes triangular, 0.3–1.2 × 1.5–2.5 mm, apex acute; corolla 17–32 mm; tube 8–19 × 1.3–2 mm; lobes 9–13 × 0.75–1.2 mm, apex rounded to obtuse; stamens included; filaments less than 0.5 mm; anthers 1.25–2 × 0.25–0.5 mm; pistil 7–9 mm; ovary ovate, 1.25–2 × ca. 1.5 mm; style ca. 7 × 0.5 mm; stigma bilobed, each lobe spatulate, 0.75–1 × 0.3–0.5 mm. Capsules ellipsoid to obovoid, 13–22 × 8–9 mm (excluding style base), tan, 3 to 12 seeds per locule (e.g., 6 to 24 seeds per fruit); seeds 7–9 × 3–4.5 mm, seed body brown, seed wings straw-gold, reticulate.

Morphology and similarities. *Bonyunia aquatica* is distinct in its obovate leaves with rounded to retuse apices. Its inflorescence and calyx are hispid as in *B. antoniifolia* and *B. spectabilis*, while other species are glabrous or nearly so. *Bonyunia aquatica* appears to be most similar to *B. antoniifolia*, *B. minor*, *B. superba*, and perhaps *B. spectabilis*.

Distribution and habitat. *Bonyunia aquatica* is a facultative emergent tree of inundated forests along riverbanks and on white sand savannas. It ranges principally along the lowlands of the Orinoco River watershed in Colombia and Venezuela, but also extends to the upper Rio Negro in Brazil at elevations of 80–180(–350) m (Fig. 1). Its range overlaps with that of outlier populations of *B. minor* in southwestern Venezuela.

IUCN Red List category. *Bonyunia aquatica* occurs in lowland areas of Brazil, Colombia, and Venezuela and has been collected in several formally protected areas such as the Reserva Florestal do Rio Negro (Brazil) and the Parque Nacional Natural

El Tuparro (Colombia). It is assigned a preliminary IUCN status of Least Concern (LC) as set forth in the IUCN Red List Categories and Criteria (IUCN, 2001).

Etymology. The epithet is taken from the Latin “aquaticus,” meaning “living in or near water,” for its facultatively aquatic habit, growing along river corridors and inundated forests.

Specimens examined. BRAZIL. **Amazonas:** Rio Curicuriary affl. Rio Negro, A. Ducke 224 (NY [2]), A. Ducke 354 (F, GH, MO, NY, S, US); Rio Negro, Içana, R. L. Fróes 22260 (IAN, U); Rio Negro, Içana, Cachoeira Tunuhy, R. L. Fróes 22278 (IAN, U); Barcelos, Río Aracá bajo, O. Huber et al. 10815 (NY [2], WAG); Rio Negro, Rio Marié, village Macobeta, K. Kubitzki et al. 79-198 (M, NY, US); s. loc., J. M. Pires et al. 14155 (IAN, RB). COLOMBIA. **Guianía:** Río Guianía, Puerto Colombia (opposite Venezuelan town of Maroa), Raudal Sapo, R. E. Schultes et al. 18240 (GH, US [2]). **Vichada:** Cumaribo, Parque Nacional Natural El Tuparro, H. Mendoza & A. Robles 15691 (FMB). VENEZUELA. **Amazonas:** Laja Alta del Guasacavi, on N bank of black-water Río Guasacavi, P. E. Berry et al. 5771 (F, K, MO, NY); Laja Suiza, upstream from mouth of black-water Río Guasacavi, 3.5 km SSW of Santa Cruz, P. E. Berry et al. 5973 (MO, NY); Atabapo, Cucurital de Caname, G. Davidse et al. 16912 (MO); Rio Negro, lower part of the Rio Baria, G. Davidse 27650 (WAG); Rio Negro, Rio Pasimoni, betw. its mouth and its jct. with the Río Baria and the Río Yatua, G. Davidse 27767 (MO, WAG); Atures, Río Guayapo, E. Foldats & J. Velazco 9423 (NY); Río Negro, final de la “lengüenta” N la Serranía Unturan, F. Guánchez 881 (MO); Atures, riberas del Río Sipapo desde la boca del Río Guayapo, F. Guánchez 2641 (MO); Atabapo, alrededores de Canaripó, bajo Río Ventuarí, a unos 20 km al. E de la confluencia con el Río Orinoco, O. Huber 1932 (COL, K, NY, US, WAG); Atabapo, sabanita ubicada a unos 10 km al. NE del Cerro Moricha, en la ribera E del medio río Ventuarí, O. Huber 3440 (NY); Atabapo, 22 km al. S de la confluencia sobre los ríos Manapiare y Ventuarí, O. Huber 3470 (B, NY, WAG); Atabapo, bajo Río Ventuarí, a unos 10 km al. NE de la desembocadura del Caño Marueta, 110 m, O. Huber 6122 (WAG); Cerro Moriche, Río Ventuarí, B. Maguire et al. 31012 (COL, F, NY, S, US [2], WAG); Atabapo, en planicie Suelo Faa, E. Marin 1126 (MO); Atabapo, 44 km al. SE de Sta. Bárbara del Orinoco, E. Marin 1188 (MO); Cano Cupaven, rt. bank of Rio Orinoco opposite mouth of Rio Atabapo, J. J. Wurdack & L. S. Adderley 42814 (COL, F, NY, S, US, WAG); Río Guainia betw. Cano San Miguel & Maroa, J. J. Wurdack & L. S. Adderley 43261 (NY, WAG).

3. *Bonyunia excelsa* J. R. Grant, sp. nov. TYPE: Colombia. Caquetá: Solano, Parque Nacional Natural Serranía de Chiribiquete, cuenca media del Río Cuñare, creciendo sobre suelo arenoso en un sitio cercano a un tepui en donde predominan *Pagamea thyrsoflora* y *Tepuianthus*, 00°29'55.32"N, 72°37'11"W, 350 m, 15 Nov. 2002, H. Mendoza, A. Escobar, S. Medina & M. Leptuama 9456 (holotype, FMB!). Figures 1, 3, 4, 7A.

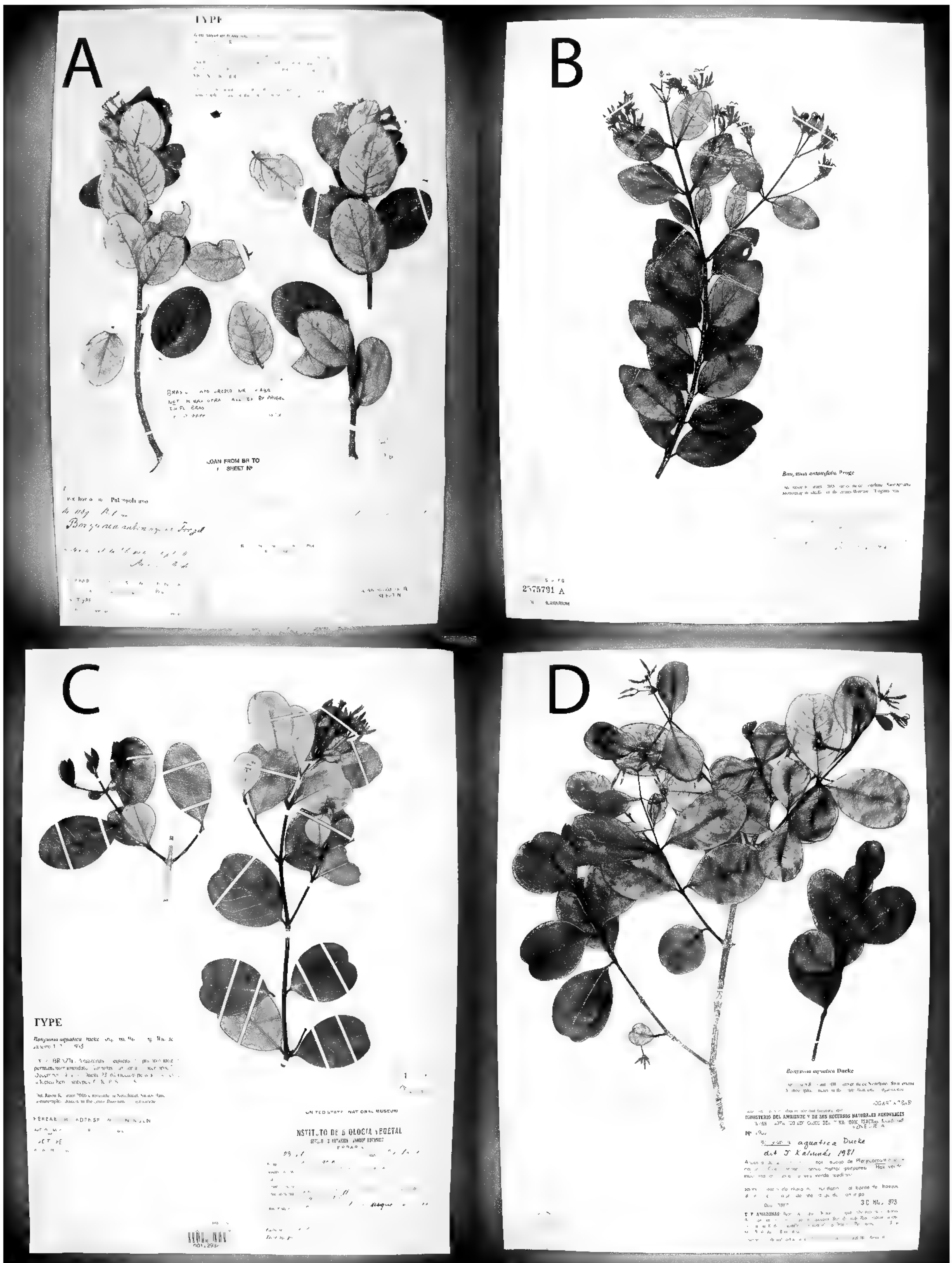

Figure 6. Types and exemplar specimens of *Bonyunia*. —A. Isotype of *B. antoniifolia* Progel (Riedel 1149 [BR]). —B. Specimen of *B. antoniifolia* Progel (Prance et al. 5758 [US]). —C. Isotype of *B. aquatica* Ducke (Ducke 23760 [US]). —D. Specimen of *B. aquatica* Ducke (Huber 1932 [NY]).

Species nova *Bonyunia antoniifolia* Progel cui affinis, sed ab ea habitu arboris excelsae (4.5–35 m vs. 5–9 m), foliis glabris, calycibus glabris vel hispidulis atque lobis calycis acuminatis vel acutis differt; etiam Sierra de Chiribiquete habitat.

Branched tree to 4.5–35 m tall, hispidulous on petioles, stems (along one side), peduncles, inflorescences, calyces, and corollas. Leaves obovate to elliptic, 4.5–6.2 cm, petiole 3–6 mm; blades 4–5.8 × 1.7–4.2 cm, glabrous, thin-coriaceous, darker adaxially, lighter abaxially, slightly glossy adaxially and more opaque abaxially, with 5 to 7 pairs of nearly parallel to arching secondary veins, smooth with slightly impressed veins adaxially, with slightly raised secondary veins abaxially; base cuneate; apex obtuse to acute. Inflorescence 5–9 cm; branches 2–5 cm, always hispid; bracts obovate to spatulate, sessile to short-petiolate, 20–28 × 7–10 mm; base attenuate to cuneate; apex obtuse, acute, to rounded; bract petioles 1–3 mm; primary flowers subsessile, secondary flowers pedicellate; pedicels 1–7 mm; bracteoles linear-triangular, 1.5–3 × 0.3–0.75 mm. Calyx campanulate, 2–3 × 2–2.5 mm, glabrous to hispidulous, ecarinate; calyx lobes triangular, 0.5–1 × 2–2.5 mm, apex acuminate to acute; corolla 12–14 mm; tube 6–7 × 1–1.5 mm; lobes 6–7 × 0.75–1 mm, apex rounded to obtuse; stamens included; filaments less than 0.5 mm; anthers 1–1.25 × 0.3–0.5 mm; pistil ca. 10 mm; ovary ovate, 1–1.5 × ca. 1 mm; style 7–8 × 0.3–0.5 mm; stigma bilobed, each lobe acuminate, 0.75–1 × 0.3–0.5 mm. Capsules ellipsoid, 23–30 × 8–9 mm (excluding style base), brown, erect, bilocular; seeds unknown.

Morphology and similarities. *Bonyunia excelsa* is a distinctive species in the open diffuse branching pattern of the inflorescence. It appears to be most similar to *B. venusta* in generally diffuse inflorescences, yet differs in having generally glabrous stems that are hispid along one side, branches of the inflorescence that are hispid all the way around, and leaves with five to seven pairs (vs. three to six pairs) of nearly parallel to arching secondary veins. It differs from *B. antoniifolia* in being a tall tree (4.5–35 m tall vs. 5–9 m), much less pubescent throughout (hispidulous vs. hispid), with glabrous calyces and acuminate to acute calyx lobes.

Distribution and habitat. *Bonyunia excelsa* occurs on plateaus and river basins on sandy soils. Both *B. excelsa* (230–350 m) and *B. nobilis* (350–400 m) are known from the Sierra de Chiribiquete, which is an isolated outlier or tepui of the Guayana region in Colombia (Fig. 1). *Bonyunia excelsa* has also been found in the Araracuara region and Río Mesay.

IUCN Red List category. *Bonyunia excelsa* is only known from three collections, one collected inside a formally protected area, the Parque Nacional Natural Serranía de Chiribiquete (Colombia). It is assigned a preliminary IUCN status of Vulnerable (VU) according to IUCN Red List Categories and Criteria (IUCN, 2001).

Etymology. The epithet is taken from the Latin “excelsus,” meaning “high” or “lofty.”

Paratypes. COLOMBIA. **Caquetá:** Araracuara, meseta de areniscas, 200–300 m, *D. Restrepo & A. Matapi* 387 (MO); Solano, Río Mesay, bocas del Yavilla, 230 m, *D. Cárdenas et al.* 6788 (COAH not seen, MO).

4. *Bonyunia magnifica* J. R. Grant, sp. nov. TYPE: Brazil. Amazonas: BR 319, Km 190, Manaus–Pôrto Velho hwy., forest on terra firme, 11 Oct. 1974, *G. T. Prance, T. D. Pennington, M. Leppard, P. P. Monteiro & J. F. Ramos* 22804 (holotype, NY!; isotypes, INPA not seen, K!, MG not seen, MO!, S!, U!, US!, WAG!). Figures 1, 2C, 3, 4, 7B.

Species nova *Bonyunia minor* N. E. Br. et *B. nobilis* J. R. Grant cui affines, sed a hac calycis lobis apice glabris, ab illa habitu arboris excelsae (usque ad 20 m), foliis majoribus (3–9.1 × 2.5–5.5 cm) discoloribus atque seminibus atroaurantiacis, ab ambabus calyce urceolato vel campanulato differt.

Branched tree to 20 m tall, glabrous throughout, except for hairs on the midvein of the undersides of leaves, pedicels, corollas, and fruits; trunk to 20 cm diam. Leaves ovate to oval, short-petiolate, 4–10 cm, petiole 3–5 mm; blades 3–9.1 × 2.5–5.5 cm, thick, coriaceous, glossy on both surfaces, distinctly discolored with the adaxial leaf surface distinctly olive-green and speckled, and the abaxial surface a solid gold-green, distinctly etched revealing a lighter color adaxially with small hieroglyphic-shaped marks, adaxial surface smooth with some slightly impressed veins, abaxial surface with prominently raised midvein and secondary veins; base rounded to slightly cordate to rarely cuneate; apex obtuse to acuminate. Inflorescence 5–9 cm; branches 2–7 cm; bracts ovate to oval, short-petiolate, 24–40 × 14–22 mm; base rounded to slightly cordate to rarely cuneate; apex obtuse to acuminate; bract petioles 1–2 mm; primary flower sessile to subsessile, secondary flowers sessile to short-pedicellate; pedicels 0–3 mm; bracteoles triangular, 1.5–3 × 0.5–1 mm. Calyx urceolate to campanulate, 4–6 × 2.5–4 mm, glabrous, ecarinate; calyx lobes triangular, 0.5–1 × 2.5–4 mm, apex acute; corolla 10–13 mm; tube 6–7 × 1–1.5 mm; lobes 5–6 × 0.5–0.75 mm, apex rounded to obtuse; stamens and pistil unknown. Capsules ellipsoid to obovoid, 15–23 × 7–8 mm (excluding style base), tan, 3 to 4 seeds per locule (e.g., 6 to 8 seeds per fruit);

seeds $14\text{--}14.5 \times 1.5\text{--}3$ mm, seed body dark orange, seed wings dark orange, reticulate.

Morphology and similarities. *Bonyunia magnifica* is unique in the genus in having an urceolate calyx. Its large, thick, coriaceous leaves are glossy on both surfaces, olive-green and specked adaxially and solid gold-green abaxially (at least when dried), with a prominent, thick, brown, raised midvein adaxially and rounded to cordate leaf base. The adaxial leaf surface of both *B. magnifica* and *B. nobilis* is covered in light specks caused by the deterioration or etching of the upper layer of cells, creating a uniform specked surface; the specks when examined under microscope have the appearance of alphabetic or hieroglyphic marks of differing shapes. The seeds of these two species have a three-dimensional aspect where the wings are slightly curled, have a less prominent difference in color between the bodies and wings, and are rather orangish in color. *Bonyunia magnifica* is related to *B. nobilis*, with which it shares its unique leaf and seed morphology as described above. It differs from *B. nobilis* in its urceolate to campanulate calyx with glabrous calyx lobes, and from *B. minor* in being a 7–20 m tall forest tree with larger discolored leaves ($3\text{--}9.1 \times 2.5\text{--}5.5$ cm).

Distribution and habitat. *Bonyunia magnifica* occurs in primary forest on terra firme in the Amazon lowlands of Brazil. It is only known from its type collection found at Km 190 on BR 319, the Manaus–Pôrto Velho Highway. Although the elevation is not specified, *B. magnifica* was certainly found between 50 and 100 m, the general elevation of lowland Amazonia. It is disjunct from its morphologically most similar species, *B. nobilis* of Colombia.

IUCN Red List category. *Bonyunia magnifica* is only known from the type collection. It is assigned a preliminary IUCN status of Critically Endangered (CR) according to IUCN Red List Categories and Criteria (IUCN, 2001).

Etymology. The epithet is taken from the Latin “magnificus,” meaning “magnificent.”

5. *Bonyunia minor* N. E. Br., Trans. Linn. Soc. London, Bot. ser. 2, 6: 49, pl. 9, figs. 1–5. 1901. TYPE: Guyana. Mt. Roraima Exped., Kotinga Valley, autumn 1894, *J. J. Quelch & F. McConnell 161* (lectotype, designated by Leeuwenberg, 1969: 156, K!). Figures 1, 2A–C, 3, 4, 7C.

Bonyunia cinchonoides Gleason & Standl., Bull. Torrey Bot. Club 58: 448. 1931. TYPE: Venezuela. Amazonas: summit of Mt. Duida, 4400 ft., Savanna Hills, Aug. 1928–Apr. 1929, *G. H. H. Tate 770* (holotype, NY!; isotype, F!).

Branched shrub to tree to 2–10 m tall, glabrous throughout, except for hairs on the petioles, peduncles, pedicels, and corolla; trunk to 5 cm diam. (*Maguire & Fanshawe 32528*). Leaves variable from individuals in savanna habitat (smaller, broadly ovate, ovate, to nearly orbicular or reniform and distinctly cordate at the base) to forest plants (larger, ovate to oval, and nearly cuneate at the base), short-petiolate, 1.1–8.6 cm, petiole 1–4 mm; blades (1–)3.2–8.4 \times (0.8–)3.3–4.5 cm, thick coriaceous, darker adaxially, lighter abaxially, adaxial surface smooth with some slightly impressed veins, abaxial surface with prominently raised midvein and secondary veins; base cordate, to rounded to cuneate; apex rounded to obtuse, to acute to nearly acuminate. Inflorescence 1.5–6 cm; branches 1–5 cm; bracts (generally as in the leaves) spatulate, obovate to ovate, short-petiolate, 5–17 \times 1.5–15 mm; base attenuate to cordate; apex obtuse to rounded; bract petioles 1–2 mm; primary and secondary flowers generally sessile; pedicels 0–1 mm; bracteoles triangular, 1–4 \times 0.5–1 mm. Calyx campanulate, 2–3.5 \times 2–2.5 mm, glabrous (to sometimes receiving a few hispid hairs from the pedicel or peduncle), ecarinate; calyx lobes triangular, 0.5–1.5 \times 2–2.5 mm, apex acute; corolla 11–17 mm; tube 7–9 \times 1.25–2.25 mm; lobes 4–8 \times 0.75–1 mm, apex rounded to obtuse; stamens included; filaments less than 0.5 mm; anthers 1.8–2 \times 0.5–0.75 mm; pistil 5.5–6 mm; ovary ovate, 1–1.5 \times ca. 1 mm; style 4–4.5 \times 0.2–0.4 mm; stigma bilobed, each lobe spatulate, 0.5–0.75 \times ca. 0.5 mm. Capsules ellipsoid to obovoid, 15–24 \times 5–8 mm (excluding style base), tan to brown, 1 to 4 seeds per locule (e.g., 2 to 8 seeds per fruit); seeds 8–10 \times 2–3 mm, seed body brown, seed wings straw-gold, reticulate.

Morphology and similarities. *Bonyunia minor* is not only the most morphologically variable species in the genus, but is also easily identifiable by its generally small cordate coriaceous leaves. Part of this variation led to the naming of *B. cinchonoides* Gleason & Standl., later reduced to synonymy under *B. minor* by Leeuwenberg (1969: 156) and also accepted here. The leaf morphology of *B. minor* varies considerably depending on whether the plants occur in open savanna or closed forest. Specimens collected in savanna tend to have smaller, more closely bunched leaves and have a tight, bushy branching pattern, while specimens collected in closed canopy forest have larger leaves in a lax branching pattern. In the savanna, the leaves are smaller, broadly ovate, ovate, to nearly orbicular or reniform, distinctly cordate at the base and rounded to obtuse at the apex; in the forest the leaves are larger, ovate to oval, and cuneate to rounded at the base, to acute to nearly acuminate at

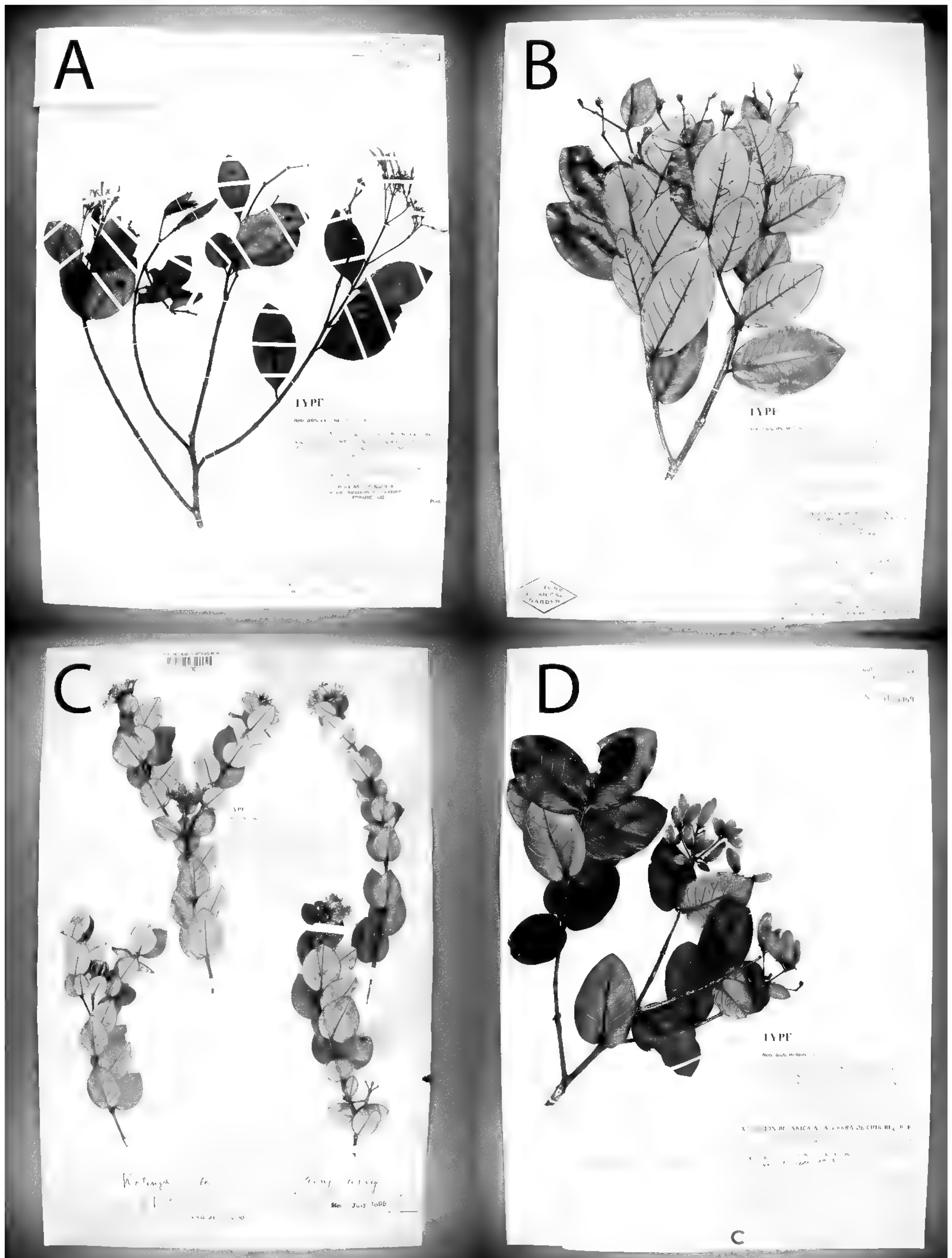

Figure 7. Types and exemplar specimens of *Bonyunia*. —A. Holotype of *B. excelsa* J. R. Grant (*Mendoza et al.* 9456 [FMB]). —B. Holotype of *B. magnifica* J. R. Grant (*Prance et al.* 22804 [NY]). —C. Lectotype of *B. minor* N. E. Br. (*Quelch & McConnell* 161 [K]). —D. Holotype of *B. nobilis* J. R. Grant (*Palacios et al.* 2393 [MO]).

the apex. *Bonyunia minor* appears to be most similar to *B. antoniifolia*, *B. aquatica*, *B. superba*, and perhaps *B. spectabilis*.

Distribution and habitat. *Bonyunia minor* is a distinctive shrub or tree of savanna, forest edges, and tepui habitats in the Guayana region in Venezuela and Guyana, especially of the Gran Sabana (Fig. 1). Its range overlaps that of *B. aquatica* to the east and *B. spectabilis* and *B. superba* to the west. It also has the widest range in elevation in the genus, ranging from 100–1450 m.

IUCN Red List category. *Bonyunia minor* occurs in the Guayana region in Venezuela and Guyana and has been collected in several formally protected areas such as the Parque Nacional Canaima, Parque Nacional Duida-Marahuaca, and Parque Nacional Yapacana of Venezuela. It is assigned a preliminary IUCN status of Least Concern (LC) as set forth in the IUCN Red List Categories and Criteria (IUCN, 2001).

Etymology. The epithet is taken from the Latin “minor,” “less,” for the small stature of some individuals, at the time described, probably in comparison to the only two other species in the genus at the time: *Bonyunia antoniifolia* and *B. superba*.

Specimens examined. BRAZIL. **Roraima:** Serra dol Sol, *Ph. Luetzelburg* 21503 (M); Río Quino Igarapé, *Ph. Luetzelburg* 21514 (M); Brazilian side of divide near Serra do Sol, *B. Maguire & C. K. Maguire* 40374 (NY, RB). GUYANA. **Cuyuni-Mazaruni:** Upper Mazaruni Distr., Imbaimodai, *Forest Dept. of British Guiana* 7921 (K, NY). **Potaro-Siparuni:** Pakaraima Mtns., Upper Ireng River watershed, Malakwalai-Tipu, *T. W. Henkel* 5699 (US); S Pakaraima Mtns., margins of Chimapu Savanna, *B. Maguire et al.* 46143A (F, NY, US, WAG); Pakaraima Mtns., Upper Mazaruni River, Samwarakna-tipu (Holi-tipu), *B. Maguire & Fanshawe* 32528 (K, NY, P, UC); 1842, *Robert Schomburgk* 966 (BM, P [not seen, but listed by van Dam, 2002]); Utshi River trail to Santa Elena, *H. D. Clarke* 913 (NY, US); Paramakatoi, 0.5–6 km from trail to Youwang & Monkey Mtn., *H. D. Clarke* 1238 (MO, NY, US); Mt. Roraima Exped., Ireng Valley, *J. J. Quelch & F. McConnell* 331 (K). VENEZUELA. **Amazonas:** Río Orinoco, Cerro Yapacana, NW slopes, *B. Maguire et al.* 30525 (NY, WAG); Cerro Moriche, Río Ventuarí, *B. Maguire* 30857 (NY); summit of Mt. Duida, Savanna Hills, *J. A. Steyermark* 58291 (F, NY); summit of Mt. Duida, Savanna Hills, *Tate* 770 (F [isotype], NY [holotype, *Bonyunia cinchonoides*]); Felsen von Serra de Mairary, Río Branco, Suramu, *E. Ule* 8469 (K, MG not seen). **Bolívar:** Sabanas a orillas del Río Hacha, Región de Canaima, *G. Agostini* 358 (US); Gran Sabana, desde Santa Elena en el Km 274, *C. Benítez & W. G. D’Arcy* 5202 (MO); Río Caroui, region de Urimán, *A. L. Bernardi* 852 (NY); Region de los ríos Icabari, Hacha, *A. L. Bernardi* 2624 (NY); Gran Sabana, Ayavaparú, 10–15 km W of Wadakapiapuéte-pui, *P. E. Berry & L. Brako* 5522 (MO, NY), *P. E. Berry & L. Brako* 5525 (MO, NY); Gran Sabana, Km 195 S of El Dorado, *P. E. Berry & L. Brako* 5530 (MO, NY); Luepa along unpaved rd. to Minicentral La Ciudadela, *P. E. Berry et al.* 6559 (MO); Ucaima, 600 m, *J. Bogner* 1080 (K, M); orillas del Río

Uaiparú, afluyente del Ikabarú, Caroní, *F. Cardona* 1914 (NY, US); cumbre del Cerro Arepuchi, Río Caroní, *F. Cardona* 1946 (NY, US, WAG); Cerro Upuimak, Caroní, *F. Cardona* 2243 (US); Gran Sabana, Parque Nacional Canaima, *L. Chacon* 595 (MO), *L. Chacon* 624 (MO), *L. Chacon* 679 (MO); Cantarrana, entre Sta. Elena e Icabarú, altopiano del Abismo, *G. Colonnello-Aznar* 845 (MO); Piar, descent from Salto Aicha to the upper basin of Río Purpur, along trail to Uriman, *G. Davidse & O. Huber* 22948 (MO, NY); Piar, lower section of Río Ambutuir, along trail to Uriman, *G. Davidse & O. Huber* 23067 (NY); Sifontes, Gran Sabana, Kavanayen, *A. Fernandez & B. Bracamonte* 3186 (MO); Atures, 1 km abajo del raudal “Ceguera” en la margen derecha del río Autana, *F. Guánchez & E. Melquero* 3633 (WAG); Carretera El Dorado–Santa Elena de Uairen, Km 127, *Holmquist* 15 (GH); Roscio, 15 km al. ESE de S. Ignacio de Yuruaní, en la cuenca alta del Río Mapaurí, *O. Huber et al.* 9130 (NY); Roscio, 10–15 km al. ENE de San Ignacio de Yuruaní, *O. Huber* 9163 (AAU); Piar, entre el Río Yuné (afluyente occidental del Río Karuay inferior) y el Caserío de Kukenán, al. ESE de la punta SE del Churi-tepui, *O. Huber* 9767 (NY); Heres, Meseta del Guaiquinima, *O. Huber* 9873 (NY); Sifontes, confluencia Yuruaní-Karaurín, *O. Huber* 11748 (US); Gran Sabana, 10 km al. SW del Wadakapiapué-tepui, *O. Huber* 11954 (AAU, NY); Heres, Meseta del Guaiquinima, a lo largo del Río Carapo, aprox. 8 km al. N del Salto Carapo, *O. Huber* 12382 (AAU, NY, US); Roscio, cuenca del Río Kanayeuta, 15 km al. NW de Sta. Elena de Uairén, *O. Huber & C. Alarcon* 6680 (K, NY, US, WAG); Roscio, Salto “La Milagrosa,” aprox. 15 km al. SW de S. Ignacio de Yuraní, *O. Huber & C. Alarcon* 7562 (NY, U, US, WAG); Roscio, WSE del Ilu-tepui, en la region del Río Caraurín medio, *O. Huber & C. Alarcon* 7696 (NY); Uaipan-tepui, SW foot of the west peak of Uaipan, along upstream of Río Pulpul, *T. Koyama & G. Agostini* 7521 (NY); Salto Yurani, *R. Kral* 72137 (NY); Alto Caroní, alrededores de Sta. Elena de Uairen, *T. Lasser* 1472 (US, NY); *T. Lasser* 1478 (NY); 17 km E of El Pauji, Río Las Ahallas, *R. L. Liesner* 19300 (MO); 0–4 km N of El Pauji on trail to Uaipaur, *R. L. Liesner* 19463 (NY); Gran Sabana, 10 km NW of Karaurin Tepui at jct. of Río Karaurin and Río Asadon (Río Sanpa), *R. L. Liesner* 23930 (MO), *R. L. Liesner* 24014 (MO); Gran Sabana, ca. 10 km NW of Karaurin Tepui at jct. of Río Karaurin and Río Asadon (Río Sanpa), *R. L. Liesner* 24016 (MO); Gran Sabana, ca. 10 km SW of Karaurin Tepui at jct. of Río Karaurin & Río Asadon (Río Sanpa), *R. L. Liesner* 24028 (MO, NY); Gran Sabana, ca. 15 km WSW of Karaurin Tepui, Quebrada Tanuan, *R. L. Liesner* 24101 (MO); Gran Sabana, 5 km S of San Ignacio de Yuraní, *R. L. Liesner* 24438 (MO); Piar, Río Acanán, 2–5 km SW of SW corner of Amaruay-tepui, *R. L. Liesner & Holst* 20485 (MO, NY); Gran Sabana, Ilu-Tepui, Gran Sabana at Kamarang Head, *B. Maguire* 33296 (NY, W); Gran Sabana, Ilu-Tepui, betw. Enemasic & San Rafael, *B. Maguire* 33591 (NY, US); Gran Sabana, Ilu-Tepui, Kavanayen, *B. Maguire* 33685 (NY); S Pakaraima Mtns., Chimapu Savanna, *B. Maguire et al.* 46149A (NY, US, WAG); betw. Vista Geral & Serra Sabang Territorio do Río Branco, *B. Maguire & C. K. Maguire* 40281 (IAN, NY, RB); betw. Caju & Vista Geral, *B. Maguire & C. K. Maguire* 40482 (NY); Mission Santa Teresita de Kavanayén, 4 km E of Mission, *B. Maguire & J. J. Wurdack* 33994 (G, NY, U); Kavanayén, trail from Misión de Santa Teresita de Kavanayén to Río Pakairau, *H. E. Moore, Jr. et al.* 9618 (NY); Gran Sabana, E de Sabanita, 1120 m, *G. Picón Nava* 1191 (US); Sabana de Medio Carrao, 8–10 km NNE of the Carrao-Churun confluence, *G. T. Prance & O. Huber* 28457 (MO, NY, WAG); Ucaima, Río Carrao above Salto Hacha, *G. T. Prance & O.*

Huber 28501 (MO, NY, US, WAG); Gran Sabana, 100 m NE of the mission at Kavanayen, *J. Pruski & J. A. Steyermark 1405* (MO, NY); La Gran Sabana, Carretera a Santa Elena de Uairen, *C. Sastre et al. 8502* (MO); Santa Teresita de Kavanayén, *J. A. Steyermark 60919* (NY); Carretera El Dorado hacia Santa Elena de Uairen, *J. A. Steyermark et al. 105489* (NY); Gran Sabana, 2 km al. N la Misión de Santa Teresita de Kavanayén, *J. A. Steyermark et al. 115510* (MO); Km 146, al. S de El Dorado, *J. A. Steyermark et al. 117557* (MO); quebrada El Cajón, Puente Luis Raúl Vásquez Z., 26.5 km al. E de Icabarú, 750 m, *J. A. Steyermark et al. 117819* (F, MO); Piar, Guadequen (Buadequen), Río Acanán (affluent of Río Carrao), W of Cerros Los Hermanos, 470 m, *J. A. Steyermark et al. 131853* (MO); Río Uarama below Uarama-tepui, NE of Luepa, *J. A. Steyermark & L. Aristeguieta 68* (NY, US); Gran Sabana, formación Roraima, Río Apongua, selva de galería a lo largo del Arautá-parú, *J. A. Steyermark et al. 104146* (NY, US); Roscio, 7.5 km al. NE de Santa Elena de Uairén, *J. A. Steyermark & R. Liesner 127575* (MO, NY); Gran Sabana, selvas de galería del Río Uarí, *F. Tamayo 3132* (US).

6. *Bonyunia nobilis* J. R. Grant, sp. nov. TYPE: Colombia. Caquetá: Sierra de Chiribiquete, Camp. Sur, al. W del campamento, sobre la ladera de la meseta, 00°55'N, 72°45'W, 400 m, 14 Dec. 1990, *P. Palacios, J. Estrada, P. Franco & J. Fuertas 2393* (holotype, MO!; isotypes, COL not seen, MA not seen). Figures 1, 2C, 3, 4, 7D.

Species nova *Bonyunia magnifica* J. R. Grant et *B. minor* N. E. Br. cui affines, sed a hac habitu arboris excelsae, foliis majoribus discoloribus atque seminibus atro-aurantiacis, ab illa calyce anguste campanulato striato lobis apice pilosis differt.

Branched tree to 7–8 m tall, glabrous throughout, except for tufts of hairs on the base of the pedicels and the apex of the calyx lobes. Leaves ovate to oval, short-petiolate, 3–9 cm, petiole 1–3 mm; blades 3–8.8 × 2–5 cm, thick coriaceous, glossy on both surfaces, distinctly discolored (adaxial leaf surface distinctly olive-green and speckled, abaxial surface solid gold-green), distinctly etched, revealing a lighter color on the adaxial surface with small alphabet/hieroglyphic-shaped marks, adaxial surface smooth with some slightly impressed veins, abaxial surface with prominently raised midvein and secondary veins; base cordate to rarely rounded; apex obtuse to acute. Inflorescence 6–10 cm; branches 3–7 cm; bracts ovate to oval, sessile to short-petiolate, 11–18 × 4–10 mm; base cuneate to rounded; apex acute; bract petioles 0–1 mm; primary and secondary flowers sessile to subsessile; pedicels 0–2 mm; bracteoles triangular, 2–2.5 × 0.5–0.75 mm. Calyx narrowly campanulate, 3.5–4.5 × 2–2.5 mm, glabrous except for tufts of hairs on apex of lobes, ecarinate, striated vertically; calyx lobes triangular, 0.3–0.75 × 2–2.5 mm, apex acute; corolla 13–16 mm; tube 7–9 × 1–1.5 mm; lobes 6–7 × 0.5–0.75 mm, apex rounded to obtuse; stamens included; filaments less than

0.5 mm; anthers ca. 2 × 0.5 mm; pistil ca. 4 mm; ovary ovate, ca. 1.5 × 1 mm; style ca. 2 × 0.2–0.4 mm; stigma bilobed, each lobe spatulate, ca. 0.5 × 0.3–0.5 mm. Capsules ellipsoid to obovoid, 22–25 × 8–10 mm (excluding style base), tan, 2 to 5 seeds per locule (e.g., 4 to 9 seeds per fruit); seeds 9–14 × 1.5–3 mm, seed body dark orange, seed wings dark orange, reticulate.

Morphology and similarities. *Bonyunia nobilis* is unique in its striated, narrowly campanulate calyx with tufts of hairs on its calyx lobe apices. Its large, thick, coriaceous leaves are glossy on both surfaces, olive-green and speckled adaxially, and solid gold-green abaxially (at least when dried), with a prominent, thick, brown, raised midvein abaxially and a rounded to cordate leaf base. The leaves and seeds of *B. nobilis* and *B. magnifica* are similar and described above under *B. magnifica*. It differs from *B. magnifica* in its narrowly campanulate striate calyx that has tufts of hairs on the calyx lobe apices, and from *B. minor* in its discolored leaves and dark orange seeds.

Distribution and habitat. *Bonyunia nobilis* occurs in forests on slopes of the plateau of the Sierra de Chiribiquete, isolated outliers of the Guayana region in Colombia (Fig. 1), at 350–400 m, with another species, *B. excelsa*.

IUCN Red List category. *Bonyunia nobilis* is only known from two collections, both collected inside a formally protected area, the Parque Nacional Natural Serranía de Chiribiquete (Colombia). It is assigned a preliminary IUCN status of Vulnerable (VU) according to IUCN Red List Categories and Criteria (IUCN, 2001).

Etymology. The epithet is taken from the Latin “nobilis,” meaning “noble.”

Paratypes. COLOMBIA. **Caquetá:** Solano, Parque Nacional Natural Serranía de Chiribiquete, 350 m, *H. Mendoza, A. Escobar, S. Medina & M. Leptuama 9558* (FMB [2]).

7. *Bonyunia pulchra* Ricketson, J. R. Grant & Liesner, sp. nov. TYPE: Peru. Amazonas: Bagua, Imaza, Tayu Mujaji, comunidad de Wawas, bosque primario, 5°15'25"S, 78°21'41"W, 800 m, 25 Oct. 1997 (fl.), *R. Rojas et al. 478* (holotype, MO!; isotypes, F!, G!, HUT!, NY!, US!, USM not seen). Figures 1, 2C, 5, 8A.

Species nova quoad seminum formam *Bonyunia magnifica* J. R. Grant et *B. nobilis* J. R. Grant ut videtur cui affinis, sed ab eis foliis tenuiter coriaceis basi cuneatis, pedicellis omnino pubescentibus atque calycis lobis acuminatis vel acutis differt.

Branched tree to 15–40 m tall, sparsely hispidulous on petioles, stems, peduncles, inflorescences, calyces,

and corollas (leaves glabrous, with random hairs on abaxial surface); trunk 11–43 cm DBH (*Morawetz & Wallnöfer V79-13888*; *Wallnöfer V62-121088*). Leaves elliptic, obovate to ovate, 3–6.5(–9.3) cm, petiole 2–6 mm; blades 2.8–6.2(–9) × 1.2–2.7(–5) cm, thin-coriaceous, darker adaxially, lighter abaxially, slightly glossy adaxially and more opaque abaxially, adaxial surface smooth with some slightly impressed veins, abaxial surface with slightly raised secondary veins; base cuneate; apex obtuse, rounded, to acute. Inflorescence 4–8 cm; branches 1.5–6 cm; bracts obovate, spatulate to triangular, sessile to short-petiolate, 3–27(–42) × 0.75–10 mm; base attenuate to cuneate; apex acuminate, acute, obtuse, to rounded; bract petioles 0–4 mm; primary and secondary flowers sessile to subsessile; pedicels 0–3 mm; bracteoles triangular, 1.5–5 × 0.5–1 mm. Calyx campanulate, 2–4 × 2–3 mm, hispidulous to glabrous, ecarinate; calyx lobes triangular, 0.75–1.5 × 2–3 mm, apex acuminate to acute; corolla 14–18 mm; tube 7–12 × 1–2 mm; lobes 5–9 × 0.75–1 mm, apex rounded to obtuse; stamens included; filaments less than 0.5 mm; anthers 1–1.5 × 0.2–0.5 mm; pistil 8–9 mm; ovary ovate, 1–2 × ca. 1.5 mm; style 5.5–7.5 × 0.3–0.5 mm; stigma bilobed, each lobe acute to acuminate, 0.75–1 × 0.5–0.75 mm. Capsules ellipsoid to obovoid, 18–23 × 5–6 mm (excluding style base), tan, 8 to 9 seeds per locule (e.g., 16 to 18 seeds per fruit); seeds 10–12 × 2–2.5 mm, seed body dark orange, seed wings dark orange, reticulate.

Morphology and similarities. *Bonyunia pulchra* has generally small leaves that are bunched together at the branch apices. Based on its seed morphology, it appears to be related to both *B. magnifica* (Brazil) and *B. nobilis* (Colombia).

Distribution and habitat. *Bonyunia pulchra* is a 15–40 m tall tree known from primary forest in the Amazon Basin-facing Andes in Amazonas and Huánuco provinces, Peru, at elevations of 500–800 m (Fig. 1).

IUCN Red List category. *Bonyunia pulchra* is known from a few collections in unprotected areas. It is assigned a preliminary IUCN status of Vulnerable (VU) according to IUCN Red List Categories and Criteria (IUCN, 2001).

Etymology. The epithet is taken from the Latin “pulcher,” meaning “beautiful.”

Notes. *Bonyunia pulchra* is co-authored by three persons, John Ricketson, Jason Grant, and Ron Liesner, who each independently determined this to be a new species.

Paratypes. PERU. **Amazonas:** Bagua, Imaza, Región del Marañon, Com. Yamayaket, Quebrada Kusu–Chapi, R.

Vásquez et al. 19847 (MO); Distr. Imaza, Comunidad Yamayakat, bosque primario, transecto 2 × 500 m, 5°03'24"S, 78°20'17"W, 600 m, arbol 15.2 cm DAP × 30 m, estéril [sterile], 29 May 1997, R. Vásquez, A. Peña, & E. Chávez 23812 (G, HUT, MO); Bagua, Imaza, Tayu Mujaji, comunidad de Wawas, 600 m, R. Vásquez et al. 24694 (DLF not seen, F not seen, G, HUT, MO, USM not seen); Bagua, Yamayakat, trocha a Putuim, 500 m, R. Vásquez & N. Jaramillo 20312 (MO, WAG). **Huánuco:** Pachitea, region of Pucallpa, western “Sira Mountains” & adjacent lowland, from 20–24 km SE of Puerto Inca, 800 m, B. Wallnöfer 14-41088 (K, W); Pachitea, Pucallpa, W part of the Sira Mtns. and adjacent lowland, from ca. 20–24 km SE of Puerto Inca, W. Morawetz & B. Wallnöfer V30-13888 (W), W. Morawetz & B. Wallnöfer V79-13888 (W), W. Morawetz & B. Wallnöfer 15-10288 (W), B. Wallnöfer V62-121088 (K, W).

8. *Bonyunia spectabilis* J. R. Grant, sp. nov. TYPE: Guyana. Cuyuni-Mazaruni: 2–5 km NW of tip of N prow of Roraima, 5°15'N, 60°35'W, 800–1000 m, mixed upland and cloud forest on talus slopes of Roraima, 22 Feb. 1989, W. Hahn & D. Gopaul 5420 (holotype, U!; isotypes, CAY not seen, F!, MO!, NY!, US!). Figures 1, 3, 4, 8B.

Species nova *Bonyunia antoniifolia* Progel cui affinis, sed ab ea caulibus glabris, pedunculis hispidis, foliis ellipticis lanceolatis oblanceolatisve longi-petiolatis basi longi-attenuatis apice acuminatis atque calyce dense appresso-strigoso vel hispido differt; etiam montem Roraimam habitat.

Branched tree to 10 m tall, glabrous throughout, except for hispid hairs on the petioles, peduncles, pedicels, corollas, and fruits. Leaves elliptic, lanceolate, to oblanceolate, long-petiolate, 7–11 cm, petiole 5–10 mm; blades 6.5–10 × 2.3–4.4 cm, thin, darker adaxially, lighter abaxially, adaxial surface smooth with some slightly impressed veins, abaxial surface with slightly raised secondary veins; base attenuate to cuneate; apex acuminate to acute. Inflorescence 2.5–4 cm; branches 1–2 cm; bracts elliptic, lanceolate, to oblanceolate (as in the upper leaves, except the petioles are pubescent; the true leaves have glabrous petioles), petiolate, 27–39(–71) × 6–10(–30) mm; base attenuate to cuneate; apex acuminate to acute; bract petioles 3–10 mm; primary and secondary flowers pedicellate; pedicels 3–7 mm; bracteoles triangular, 1–2 × 0.5–1 mm. Calyx campanulate, 3–4.5 × 2.5–4 mm, densely appressed strigose to hispid, ecarinate; calyx lobes triangular, 0.75–1 × 2.5–4 mm, apex acuminate to acute; corolla poorly known (a single immature corolla on *Hahn & Gopaul 5420* [US] is illustrated, but measurements not taken); stamens and pistil unknown. Capsules somewhat immature, but description still prepared, narrowly ellipsoid, 11–13 × 3–4 mm (excluding style base), tan, 14 to 20 seeds per locule (e.g., 28 to 40 seeds per fruit). Only immature seeds seen.

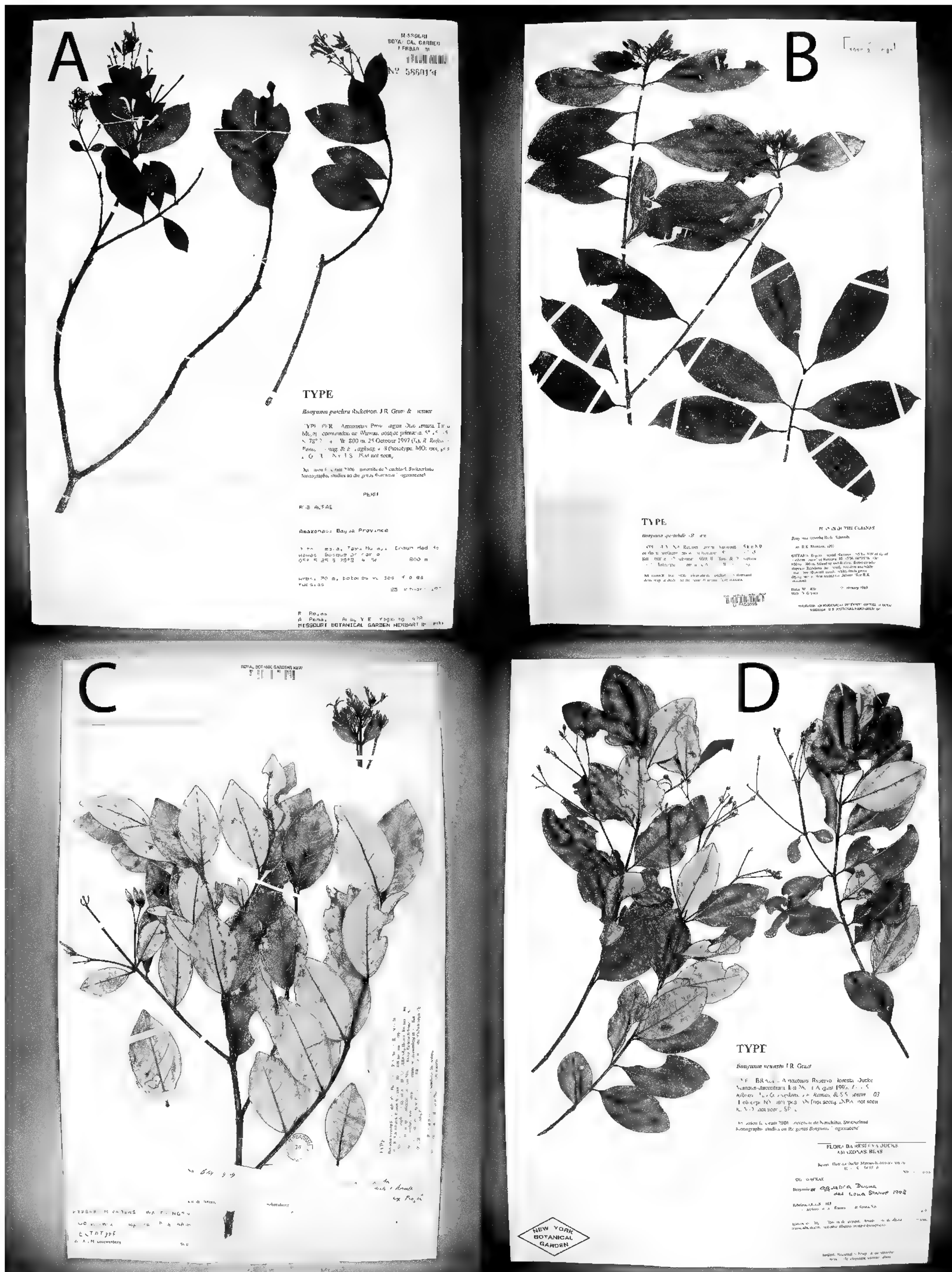

Figure 8. Types of *Bonyunia*. —A. Holotype of *B. pulchra* Ricketson, J. R. Grant & Liesner (Rojas et al. 478 [MO]). —B. Holotype of *B. spectabilis* J. R. Grant (Hahn & Gopaul 5420 [U]). —C. Lectotype of *B. superba* M. R. Schomb. ex Progel (Schomburgk 614 (939) [K]). —D. Holotype of *B. venusta* J. R. Grant (Ribeiro et al. 1103 [NY]).

Morphology and similarities. *Bonyunia spectabilis* has several unique characters, notably in that the inflorescence is pubescent (peduncles, petioles of bracts, calyces, and corolla), yet the leaves and stems are glabrous below. It is similar to *B. antoniifolia* and *B. aquatica* in having pubescent calyces, but is much more densely hispid than the other two. It is also the only species in the genus with long petioles (5–10 mm) and narrowly elliptic leaves. *Bonyunia spectabilis* appears to be most similar to *B. antoniifolia*, *B. aquatica*, *B. minor*, and *B. superba*. Even if only immature seeds are known from *B. spectabilis* and therefore not illustrated or described in full, they resemble those of these four species.

Distribution and habitat. *Bonyunia spectabilis* occurs on talus slopes of mixed upland cloud forest on white sand and boulders. It is only known from its type specimen collected on Mount Roraima along the border of Brazil, Guyana, and Venezuela (Fig. 1). It may be sympatric with *B. minor* and *B. superba*, especially *B. superba*, which has been most often collected on Mount Roraima.

IUCN Red List category. *Bonyunia spectabilis* is only known from the type collection, from a formally protected area, the Parque Nacional Canaima (Venezuela). It is assigned a preliminary IUCN status of Critically Endangered (CR) according to IUCN Red List Categories and Criteria (IUCN, 2001).

Etymology. The epithet is taken from the Latin “spectabilis,” meaning “showy.”

9. *Bonyunia superba* M. R. Schomb. ex Progel, Fl. Bras. (Martius) 6(1): 267, tab. 72. 1868. TYPE: Venezuela. Bolivar: Mt. Roraima, “Our Village, near Canaupang settlement (van Dam, 2002),” 1842–1843 [28 Oct.–4 Dec. 1842], *Robert Schomburgk 614* [– *Richard Schomburgk 939*] (lectotype, designated by Leeuwenberg, 1969: 158, K!; isotypes, BM [2]!, BR!, F [2]!, G [3]!, GH!, K [2]!, P!, U!, W!). Figures 1, 2C, 3, 4, 8C.

Branched shrub to tree to 1.8–7.6 m tall, hispid throughout especially on the midvein and secondary veins of the undersides of leaves, petioles, peduncles, inflorescences, and corollas, glabrous only on abaxial leaf surfaces and notably glabrous on the calyx; trunk up to 20 cm in diam. (*Pinkus* 270). Leaves ovate, oval, to elliptic, short-petiolate, (3.5–)6–9 cm, petiole 3–5 mm; blades (3.2–)5.5–8.5 × (2.3–)3–5.5 cm, thick coriaceous, darker adaxially, lighter abaxially, slightly glossy adaxially and more opaque abaxially, adaxial surface smooth with some slightly impressed veins, abaxial surface with prominently raised midvein and secondary veins; base rounded to cuneate; apex

obtuse to acuminate. Inflorescence 2.5–6 cm; branches 2–6 cm; bracts ovate, elliptic, lanceolate, to spatulate (as in the bracteoles above), sessile to short-petiolate, 9–37 × 3–18 mm; base rounded to cuneate; apex obtuse to acute; bract petioles 0–2 mm; primary flower sessile to subsessile, secondary flowers pedicellate; pedicels 1–10 mm; bracteoles distinctly spatulate to obovate, with a prominent midvein, equaling to much exceeding the length of the calyx lobes, 6–10 × 1–2 mm. Calyx campanulate, 5–10 × 2–2.5 mm, glabrous, ecarinate to slightly keeled along midvein; calyx lobes spatulate to obovate, as in the bracteoles, 2–6 × 2–2.5 mm, apex rounded to obtuse; corolla 15–17 mm; tube 10–17 × 1.5–2 mm; lobes 5–7 × 0.75–1 mm, apex rounded to obtuse; stamens included; filaments less than 0.5 mm; anthers 1.8–2 × 0.25–0.5 mm; pistil 6–7 mm; ovary ovate, 1.5–2 × ca. 1.5 mm; style 4–5 × 0.2–0.4 mm; stigma bilobed, each lobe spatulate, 0.75–1 × 0.3–0.5 mm. Capsules fusiform to ellipsoid, 15–33 × 5–8 mm (excluding style base), tan, 3 to 10 seeds per locule (e.g., 6 to 20 seeds per fruit); seeds 11–17 × 2.5–3 mm, seed body brown, seed wings straw-gold, reticulate.

Morphology and similarities. *Bonyunia superba* is exceptional in the genus in having long pedicels (1–10 mm), spatulate to obovate bracteoles equaling to much exceeding the length of the calyx lobes, and spatulate to obovate calyx lobes. In its hispid pubescence nearly throughout it is similar to both *B. antoniifolia* and *B. aquatica*. *Bonyunia superba* appears to be most similar to *B. antoniifolia*, *B. aquatica*, *B. minor*, and perhaps *B. spectabilis*.

Distribution and habitat. *Bonyunia superba* occurs with *B. spectabilis* in the forest of Mount Roraima on the Venezuela–Guyana border on the Pantepui of the Guayana region (Fig. 1). The two species are possibly sympatric with outlying populations of *B. minor*. Despite being so distinct, *B. superba* has actually been seldom collected in comparison to *B. minor*.

IUCN Red List category. *Bonyunia superba* is known from few collections, most from a formally protected area, the Parque Nacional Canaima (Venezuela). It is assigned a preliminary IUCN status of Vulnerable (VU) according to IUCN Red List Categories and Criteria (IUCN, 2001).

Etymology. The epithet is taken from the Latin “superbus,” meaning “excellent.”

Typification. The herbarium labels of *Schomburgk 614* (939) have little text, but collection locality can be pieced together from the labels and the protologues. The two separate collection “numbers” refer to the two numbering systems of Richard and Robert

Schomburgk (van Dam, 2002). The first number, 614, is from Robert's second collection series, which corresponds to number 939 in Richard's series (van Dam, 2002). There are samples of both at Kew.

Richard Schomburgk (1848) gives the locality of *Bonyunia superba* as "In der Umgebung von Our Village an den Rändern der Waldungen" (In the surroundings of Our Village, at the forest edge). Progel (1868) translates this text to Latin as "In Guyanae anglicae montibus Roraima, ad margines silvarum prope Our Village in formatione arenacea" (In British Guiana on Mount Roraima, at forest edges near Our Village on sandy soils). When Robert and Richard Schomburgk traveled to Mount Roraima, they set up camp on the Kukenaam River, naming their site "Our Village." From there, they made their ascent to Mount Roraima and, in this region, collected many plants including *B. superba*. According to van Dam (2002), however, Our Village was near the settlement of Canapang and is actually situated in present-day Venezuela rather than Guyana. Richard collected around Our Village and Mount Roraima from 28 October–4 December 1842. The original material on which Schomburgk based his description was deposited at Berlin but destroyed during World War II, which probably led Leeuwenberg to lectotypify *B. superba* on material at K.

Specimens examined. GUYANA. **Cuyuni-Mazaruni:** Krabu Mountain slope, shrub to 6 ft. in height [1.8 m] found in scrubby forest on the slope of Krabu Mountain, 6.11.1966, Field No.: R.B. 160, Record No.: *Forest Dept. of British Guiana 7993* (NY). VENEZUELA. **Bolívar:** 2–10 km from El Dorado–Santa Elena Rd. on rd. to Kavanayen, 1200–1250 m, Gran Sabana, gallery forest and grassland, *A. Gentry et al. 10511* (MO, NY, US); Mt. Roraima Distr., vic. of Arabupu, 4200 ft. [1280 m], *A. S. Pinkus 270* (F, G, NY [2], S, US).

10. *Bonyunia venusta* J. R. Grant, sp. nov. TYPE: Brazil. Amazonas: Reserva Florestal Ducke, Manaus–Itacoatiara, Km 26, 2°53'S, 59°58'W, [ca. 50–100 m], Igarapé do Tinga, Floresta de Vertente, INPA No. 179666, 11 Aug. 1993, *J. E. L. S. Ribeiro, M. J. G. Hopkins, J. F. Ramos & S. S. Sousa 1103* (holotype, NY!; isotypes, IAN not seen, INPA not seen, K!, MO not seen, SP!, U!). Figures 1, 3, 4, 8D.

Species nova *Bonyunia antoniifolia* Progel cui affinis, sed ab ea foliis et calycibus glabris, lobis calycis acuminatis vel acutis, inflorescentia diffusa atque pedicellis interdum longioribus (1–10 vs. 1–5 mm) differt.

Branched tree to 15 m tall, hispidulous on petioles, stems, peduncles, inflorescences, calyces, and corollas (leaves glabrous adaxially and abaxially); bark violet on the outside, chestnut inside, albumen whitish cream. Leaves oval, elliptic, to ovate, short-petiolate,

4–7.5 cm, with 3 to 6 pairs of arching secondary veins, petiole 4–6 mm; blades 3.5–7 × 2–3.3 cm, thin-coriaceous, darker adaxially, lighter abaxially, slightly glossy adaxially and more opaque abaxially, adaxial surface smooth with some slightly impressed veins, abaxial surface with slightly raised secondary veins; base cuneate; apex obtuse to acute. Inflorescence 7–12 cm; branches 2.5–7 cm; bracts ovate, elliptic, to lanceolate, petiolate, 18–27 × 3–10 mm; base attenuate to cuneate; apex obtuse, acute, to rounded; bract petioles 3–6 mm; primary and secondary flowers pedicellate; pedicels 1–10 mm; bracteoles linear-triangular, 1.5–4 × 0.3–0.75 mm. Calyx campanulate, 2–3.5 × 1.5–1.75 mm, glabrous to rarely hispidulous, ecarinate; calyx lobes triangular, 0.3–1 × 1.5–1.75 mm, apex acuminate to acute; corolla, stamens, pistil, capsules, and seeds unknown.

Morphology and similarities. *Bonyunia venusta* appears to be most similar to *B. excelsa* and perhaps also to *B. antoniifolia*. It differs from *B. excelsa* in having stems and branches of the inflorescence equally hispidulous and leaves with three to six pairs of arching secondary veins. It differs from *B. antoniifolia* in being much less pubescent throughout, with glabrous leaves and calyces, a more diffuse inflorescence, and longer pedicels (1–10 mm vs. 1–5 mm).

Distribution and habitat. *Bonyunia venusta* is only known from its type material collected on terra firme in closed canopy forest in the Amazon lowlands of Brazil in the Reserva Florestal Ducke just north of Manaus, at elevations of 50–100 m (Fig. 1). Of the four types of terra firme forest in the park, it was collected on "Floresta de Vertente," which is a sloped transition zone between a higher and lower type forest. It was described and illustrated in the *Flora da Reserva Ducke* as *B. aquatica* (Ribeiro et al., 1999: 564).

IUCN Red List category. *Bonyunia venusta* is only known from the type collection, from a formally protected area, the Reserva Florestal Ducke (Brazil). It is assigned a preliminary IUCN status of Critically Endangered (CR) according to IUCN Red List Categories and Criteria (IUCN, 2001).

Etymology. The epithet is taken from the Latin "venustus," meaning "attractive" or "graceful."

Literature Cited

- Angiosperm Phylogeny Group. 2003. An update of the Angiosperm Phylogeny Group classification for the orders and families of flowering plants: APG II. *Bot. J. Linn. Soc.* 141: 399–436.
- Backlund, M., B. Oxelman & B. Bremer. 2000. Phylogenetic relationships within the Gentianales based on *ndhF* and *rbcL* sequences, with particular reference to the Loganiaceae. *Amer. J. Bot.* 87: 1029–1043.

- Berry, P. E. 2001. *Bonyunia* (Loganiaceae). Pp. 24–26 in P. E. Berry, K. Yatskiyevych & B. K. Holst (editors), *Flora of the Venezuelan Guayana*, Vol. 6: Liliaceae–Myrsinaceae. Missouri Botanical Garden Press, St. Louis.
- Bonyun, G. R. 1844. On the Demerara Pink-root, or *Spigelia Anthelmia*. *Ann. Mag. Nat. Hist.* 14: 461–463.
- . 1848. Colonial Office and Predecessors: British Guiana, Formerly Berbice, Demerara, and Essequibo, Original Correspondence CO 111/250. Despatch No. 10: Dr. Bonyun's Report on State of Immigrants. The National Archives of the United Kingdom, Kew.
- Bremer, B. & L. Struwe. 1992. Phylogeny of the Rubiaceae and the Loganiaceae: Congruence or conflict between morphological and molecular data? *Amer. J. Bot.* 79: 1171–1184.
- Brown, N. E. 1901. Report on two botanical collections made by Mssrs. F. V. McConnell and J. J. Quelch of Mount Roraima in British Guiana. *Trans. Linn. Soc. London, Bot. ser. 2*, 6: 1–107.
- Ducke, A. 1935. Plantes nouvelles ou peu connues de la région amazonienne (VII^{ème} série). *Arq. Inst. Biol. Veg.* 1: 205–212.
- Gleason, H. A. 1931. Botanical results of the Tyler-Duida Expedition. *Bull. Torrey Bot. Club* 58(7): 406–464.
- IUCN. 2001. IUCN Red List Categories and Criteria, Version 3.2. Prepared by the IUCN Species Survival Commission. IUCN, Gland, Switzerland, and Cambridge, United Kingdom.
- Leeuwenberg, A. J. M. 1969. Notes on American Loganiaceae III: Revision of *Bonyunia* Rich. *Schomb. Acta Bot. Neerl.* 18(1): 152–158.
- Maguire, B. & R. E. Weaver Jr. 1975. The neotropical genus *Tachia* (Gentianaceae). *J. Arnold Arbor.* 56(1): 103–125.
- Mori, S. A. & J. L. Brown. 1994. Report on wind dispersal in a lowland moist forest in central French Guiana. *Brittonia* 46: 105–125.
- , G. Cremers, C. A. Gracie, J. J. de Granville, S. V. Heald, M. Hoff & J. D. Mitchell. 2002. Guide to the Vascular Plants of Central French Guiana. *Mem. New York Bot. Gard.* 76(2).
- Peters, W., M. O. Kinkade, A. M. Pohlit & L. Struwe. 2004. *Tachia* Field Guide. Rutgers University–Cook College, New Brunswick, New Jersey.
- Progel, A. 1868. Loganiaceae. In C. F. P. von Martius, *Flora Brasiliensis*, Vol. 6, Pt. 1: 249–290.
- Ribeiro, J. R. L. da S., M. J. G. Hopkins, A. Vicentini, C. A. Sothers, M. A. da S. Costa, J. M. de Brito, M. A. D. de Souza, L. H. P. Martins, L. G. Lohmann, P. A. C. L. Assunção, E. da C. Pereira, C. F. da Silva, M. R. Mesquita & L. C. Procópio. 1999. Flora da Reserva Ducke: Guia de Identificação das Plantas Vasculares de uma Floresta de Terra-firme na Amazônia Central. INPA-DFID, Manaus.
- Schomburgk, Richard. 1847–1848. *Reisen in Britisch-Guiana in den Jahren 1840–1844*, Vols. 1–3. J. J. Weber, Leipzig.
- Struwe, L. & V. A. Albert. 1997. Floristics, cladistics, and classification: Three case studies in Gentianales. Pp. 351–352 in J. Dransfield, M. J. E. Coode & D. A. Simpson (editors), *Plant Diversity in Malesia III*. Royal Botanic Gardens, Kew, Richmond.
- & ———. 2004. A monograph of neotropical *Potalia* Aublet (Gentianaceae: Potalieae). *Syst. Bot.* 29(3): 670–701.
- & T. J. Motley. Loganiaceae (including Antoniaceae, Geniostomaceae, Spigeliaceae, and Strychnaceae). In J. W. Kadereit (editor), *Families and Genera of Vascular Plants: Asteridaceae–Gentianales*. Springer Verlag, Berlin. In press.
- , ——— & B. Bremer. 1994. Cladistics and family level classification of the Gentianales. *Cladistics* 10: 175–206.
- , M. Thiv, J. W. Kadereit, A. S.-R. Pepper, T. J. Motley, P. J. White, J. H. E. Rova, K. Potgieter & V. A. Albert. 1998. *Saccifolium* (Saccifoliaceae), an endemic of Sierra de la Neblina on the Brazilian-Venezuelan border, related to a temperate-alpine lineage of Gentianaceae. *Harvard Pap. Bot.* 3(2): 199–214.
- , M. P. Kinkade & P. J. M. Maas. 2005. Two new Brazilian species of *Tachia* (Gentianaceae: Helieae). *Blumea* 50: 457–462.
- , S. Haag, E. Heiberg & J. R. Grant. 2009. Andean speciation and vicariance in Neotropical *Macrocarpaea* (Gentianaceae–Helieae). *Ann. Missouri Bot. Gard.* 96: 450–469.
- Urban, I. 1906. *Vitae itineraque collectorum botanicorum, notae collaboratum biographicae, flora brasiliensis ratio edendi chronologica, systema, index familiarum*. In C. F. P. Martius, *Flora Brasiliensis*, Vol. 1, Pt. 1: 1–268.
- van Dam, J. A. C. & M. J. Jansen-Jacobs (editors). 2002. *Flora of the Guianas: Supplementary Series: Fasc. 3. The Guyanan Plant Collections of Robert and Richard Schomburgk*. Kew Publishing, Kew, Richmond.

APPENDIX 1. Numbered collections of *Bonyunia* examined. Species in boldface in the List of Species represent new species. The numbers in brackets indicate identifications following the List of Species. Collections are arranged by collector's last name. Type collections are indicated by asterisks.

LIST OF SPECIES

1. *B. antoniifolia* Progel
 2. *B. aquatica* Ducke
 3. ***B. excelsa*** J. R. Grant
 4. ***B. magnifica*** J. R. Grant
 5. *B. minor* N. E. Br.
 6. ***B. nobilis*** J. R. Grant
 7. ***B. pulchra*** Ricketson, J. R. Grant & Liesner
 8. ***B. spectabilis*** J. R. Grant
 9. *B. superba* M. R. Schomb. ex Progel
 10. ***B. venusta*** J. R. Grant
- Agostini, G.* 358 (US [5]). *Amaral, B. L.* 44 (RB [1]). *Amaral, I. L.* 112495 (NY [1]). *Benítez, C.* 5202 (MO [5]). *Bernardi, A. L.* 852 (NY [5]), 2624 (NY [5]). *Berry, P. E.* 5522 (MO, NY [5]), 5525 (MO, NY [5]), 5530 (MO, NY [5]), 5771 (F, K, MO, NY [2]), 5973 (MO, NY [2]), 6559 (MO [5]). *Bogner, J.* 1080 (K, M [5]). *Cárdenas, D.* 6788 (COAH, MO [3]). *Cardona, F.* 1914 (NY, US [5]), 1946 (NY, US, WAG [5]), 2243 (US [5]). *Cavalcanti, G. P.* 2377 (K [1]). *Chacon, L.* 595 (MO [5]), 624 (MO [5]), 679 (MO [5]). *Clarke, H. D.* 913 (NY, US [5]), 1238 (MO, NY, US [5]). *Colonnello-Aznar, G.* 845 (MO [5]). *Dambrós, L. A.* 356 (US [1]). *Davidse, G.* 16912 (MO [2]), 22948 (MO, NY [5]), 23067 (NY [5]), 27650 (WAG [2]), 27767 (MO, WAG [2]). *Ducke, A.* 224 (NY [2]), 354 (F, GH, MO, NY, S, US [2]), 379 (S [1]), 680 (F, MG, MO, NY, UC, US [1]), 738 (F [1]), 5738 (S [1]), 11184 (BM, G, RB, S, U [1]), 11534 (G [1]), 12197 (BM, G, P, US [1]), 12384 (BM, G, RB, US [1]), 23760* (G, K, P, RB, S, U, US [2]). *Fernandez, A.* 3186 (MO [5]). *Ferreira, C. A. C.* 5603 (MO, NY, WAG [1]), 5688 (MO, NY, WAG [1]), 6540 (MO, NY, WAG [1]). *Foldats, E. & J. Velazco* 9423 (NY [2]). *Forest Dept. of British Guiana* 7921 (K, NY [5]), 7993 (NY [9]). *Fróes, R. L.* 22260 (IAN, U [2]), 22278 (IAN, U [2]).

Gentry, A. 10511 (MO, NY, US [9]). *Guánchez, F.* 881 (MO [2]), 2641 (MO [2]), 3633 (WAG [5]). *Guillén, R.* 2315 (MA, NY, USZ [1]), 2513 (G, MA, MO, NY, USZ [1]), 4161 (F, MA, NY, USZ [1]). *Gutiérrez, E.* 1323 (G, MO, NY, USZ [1]), 1444 (MO, USZ [1]).

Hahn, W. & D. Gopaul 5420* (CAY, F, MO, NY, U, US [8]). *Henkel, T. W.* 5699 (US [5]). *Holmquist* 15 (GH [5]). *Huber, O.* 1932 (COL, K, NY, US, WAG [2]), 3440 (NY [2]), 3470 (B, NY, WAG [2]), 6122 (WAG [2]), 6680 (K, NY, US, WAG [5]), 7562 (NY, U, US, WAG [5]), 7696 (NY [5]), 9130 (NY [5]), 9163 (AAU [5]), 9767 (NY [5]), 9873 (NY [5]), 10815 (NY, WAG [2]), 12382 (AAU, NY, US [5]), 11748 (US [5]), 11954 (AAU, NY [5]).

Janssen, A. 640 (M). *Janssen & Gemtchujnicov* 306 (M).

Killeen, T. 2749 (NY [1]), 6501 (F, MO, NY, USZ [1]), 7080 (MO, NY, USZ [1]). *Koyama, T.* 7521 (NY [5]). *Kral, R.* 72137 (NY [5]). *Kubitzki, K.* 79-47 (MG, NY [1]), 79-198 (M, NY, US [2]). *Kuhlmann, J. G.* 2233 (SP [1]).

Lasser, T. 1472 (NY, US [5]), 1478 (NY [5]). *Liesner, R. L.* 19300 (MO [5]), 19463 (NY [5]), 20485 (MO, NY [5]), 23930 (MO [5]), 24014 (MO [5]), 24016 (MO [5]), 24028 (MO, NY [5]), 24101 (MO [5]), 24438 (MO [5]). *Lleras, E.* P19452 (U, WAG [1]). *Luetzelburg, Ph.* 21503 (M [5]), 21514 (M [5]).

Maguire, B. 30525 (NY, WAG [5]), 30857 (NY [5]), 31012 (COL, F, NY, S, US [2], WAG), 32528 (K, NY, P, UC [5]), 33296 (NY, W [5]), 33591 (NY, US [5]), 33685 (NY [5]), 33994 (G, NY, U [5]), 40281 (IAN, NY, RB [5]), 40374 (NY, RB [5]), 40482 (NY [5]), 46143A (F, NY, US, WAG [5]), 46149A (NY, US, WAG [5]). *Marin, E.* 1126 (MO [2]), 1188 (MO [2]). *Mendoza, H.* 9456* (FMB [3]), 9558 (FMB [6]), 15691 (FMB [2]). *Moore, H. E.* 9618 (NY [5]). *Morawetz, W.* 15-10288 (W [7]), V30-13888 (W [7]), V79-13888 (W [7]). *Mostacedo, B.* 1815 (G, NY, USZ [1]), 1861 (G, MO, NY, USZ [1]).

Nelson, B. 1388 (MO, WAG [1]).

Palacios, P. 2393* (COL, MA, MO [6]). *Paula, J. E. de* 1907 (Z [1]). *Pena, B.* 2005 (MG, RB [1]). *Peña, M.* 170 (NY [1]). *Picón Nava, G.* 1191 (US [5]). *Pinkus, A. S.* 270 (F, G, NY, S, US [9]). *Pires, J. M.* 14155 (IAN, RB [2]). *Prance, G. T.* 5758 (COL, F, GH, K, MG, NY, R, S, U, US, Z [1]), 13796 (K, MG, MO, NY, RB, U, US, WAG [1]), 22804* (INPA, K, MG, MO, NY, U, US, WAG [4]), 28457 (MO, NY, WAG [5]), 28501 (MO, NY, US, WAG [5]), 30033 (MO, NY, WAG [1]). *Pruski, J.* 1405 (MO, NY [5]).

Quelch, J. J. 161* (K [5]), 331 (K [5]). *Quevedo, R.* 973 (G, MO, NY, USZ [1]).

Restrepo, D. 387 (MO [3]). *Ribeiro, J. E. L. S.* 1103* (IAN, INPA, K, MO, NY, SP, U [10]). *Riedel, L.* 1149* (BR, LE, MO, R, NY [1]). *Rodrigues, W.* 8547 (US [1]). *Rojas, R.* 478* (F, G, HUT, MO, NY, US, USM [7]).

Sastre, C. 8502 (MO [5]). *Schomburgk, R.* 614* (BM, BR, F, G, GH, K, P, U, W [9]), 939 (F [9]), 966 (BM, P [5]). *Schultes, R. E.* 18240 (GH, US [2]). *Silva, M. N.* 28 (MO, NY, WAG [1]). *Steyermark, J. A.* 68 (NY, US [5]), 58291 (F, NY [5]), 60919 (NY [5]), 104146 (NY, US [5]), 105489 (NY [5]), 115510 (MO [5]), 117557 (MO [5]), 117819 (F, MO [5]), 127575 (MO, NY [5]), 131853 (MO [5]).

Tamayo, F. 3132 (US [5]). *Tate, G. H. H.* 770 (F, NY [5]). *Teixeira, L. O. A.* 266 (NY, WAG [1]), 1268 (MG, MO, NY, RB, US, WAG [1]).

Ule, E. 8469 (K, MG [5]).

Vargas, L. 830 (WAG [1]). *Vásquez, R.* 19847 (MO [7]), 20312 (MO, WAG [7]), 23812 (G, HUT, MO [7]), 24694 (DLF, F, G, HUT, MO, USM [7]). *Vieira, G.* 149 (K, NY, US, WAG [1]).

Wallnöfer, B. 14-41088* (K, W [7]), V62-121088 (K, W [7]). *Wurdack, J. J.* 42814 (COL, F, NY, S, US, WAG [2]), 43261 (NY, WAG [2]).

PHYLOGENETIC POSITION AND
TAXONOMIC CLASSIFICATION OF
AETHIONEMA TRINERVIUM
(BRASSICACEAE): A
MORPHOLOGICALLY VARIABLE
SUBSHRUB FROM
SOUTHWESTERN ASIA¹

Ahmad Reza Khosravi,^{2*} Fernand Jacquemoud,³
Sasan Mohsenzadeh,² Marck Menke,⁴
and Klaus Mummenhoff⁵

ABSTRACT

Due in part to its distinctive and variable morphology, traditional taxonomy has not resolved the systematic position of *Aethionema trinervium* Boiss., which has been previously placed in several different genera including *Aethionema* R. Br., *Eunomia* DC., *Hutchinsia* R. Br., and *Thlaspi* L. Using sequence data from the ITS-1 and ITS-2 regions of ribosomal DNA, *A. trinervium* has been added to a previously published data set composed of proposed congeners and related taxa in order to clarify its phylogenetic relationships. Our molecular analysis indicates that *A. trinervium* is not a member of *Aethionema*, but is instead highly nested within *Vania* F. K. Mey., a segregate lineage of the nonmonophyletic *Thlaspi* s.l. Based on these results and subsequent taxonomic recommendations, we transfer *A. trinervium* to *Vania*, described from Iran, as the new combination *V. trinervia* (DC.) Khosravi, Jacquemoud, Menke, Mumm. & Mohsenz. Furthermore, we have lectotypified the species.

Key words: *Aethionema*, Brassicaceae, ITS sequence analysis, *Noccaea*, phylogenetic relationships, Southwest Asia, *Thlaspi*, *Vania*.

Returning to previously analyzed molecular data sets with additional data is a valid and efficient method for increasing our overall phylogenetic knowledge and for giving additional emphasis to more narrowly focused questions, such as clarifying the taxonomic placement of a single problematic species (Mummenhoff et al., 1997a, b, 2001; Crawford et al., 2001; Warwick et al., 2006a).

In the present study, we demonstrate the utility of sequences from the ITS region of nuclear ribosomal DNA to resolve the generic affinities of a problematic species in the Brassicaceae, i.e., *Aethionema trinervium* Boiss., a perennial subshrub. It is distributed in Afghanistan, Turkmenistan, Iran, Transcaucasia, Turkey, and northern Iraq (Hedge, 1965, 1968). The plants are essentially glabrous and woody at the base,

with the ascending stems remaining herbaceous (Hedge, 1965). Leaves are strongly palmately veined, amplexicaul, mostly 10–20 mm in length, and variously shaped from lanceolate to ovate to oblong with the basal auricles varying from almost absent to sagittately elongate. Leaf shape may vary dramatically on a single individual between the proximal and distal leaves of the same shoot. The inflorescence is racemose, starting as a condensed head but elongating in fruit (Hedge, 1965, 1968). Sepals are erect, petals are white and 1-nerved at the base, filaments are free, and anthers are apiculate (Hedge, 1965). Silicles are angustiseptate and 4–10 mm in length, and they vary from lanceolate to oblong. Furthermore, fruit valve wings may be present or absent. If present, the wings vary in shape from broadly obovate or squarely

¹ We thank Shahin Zarre for critically reading the draft manuscript and Seid Mansoore Mirtadzadini for kindly providing leaf material from his collection. Gérard Aymonin (P) kindly provided information about the collections of Michaux and Olivier and Bruguière and two digital images of *Hutchinsia trinervia* DC. Patrick Perret, curator of the library at G, permitted the reproduction of the illustration of *Hutchinsia trinervia* DC. from *Icones selectae plantarum*, and Patricia Riedy (G) scanned the image. We also thank Victoria C. Hollowell for editorial advice and Beth Parada and Allison Brock for assistance preparing the manuscript for publication.

² Department of Biology, Faculty of Science, Shiraz University, Shiraz 71454, Iran.

³ Conservatoire botanique de la Ville de Genève, Case postale 60, CH-1292 Chambésy, Switzerland.

⁴ Department of Biology, Washington University, St. Louis, Missouri 63130, U.S.A.; Missouri Botanical Garden, P.O. Box 299, St. Louis, Missouri 63166-0299, U.S.A.

⁵ Department of Biology, Systematic Botany, University of Osnabrück, Barbarastrasse 11, 49076 Osnabrück, Germany.

* Author for correspondence: khosravi@biology.susc.ac.ir.

doi: 10.3417/2007004

oblong or reduced to a narrow margin (Hedge, 1965, 1968). The seed surface is smooth (Hedge, 1965). Individuals collected at higher elevations (above 3000 m) tend to have markedly smaller leaves and display a subplicate habit (Hedge, 1965, 1968).

Morphologically, the evidence for placing the species in *Aethionema* R. Br. is equivocal, with many vegetative features of *A. trinervium* being atypical for the genus. However, there are examples in which some unusual morphological states are approached in at least one other species of *Aethionema*. For example, the prominent palmate leaf venation in the annual *A. arabicum* (L.) Andr. ex DC. resembles that of *A. trinervium*. Also, while no other *Aethionema* species possesses auriculate or amplexicaul leaves, the cordate and short petiolate leaves of *A. cordatum* Boiss. approach such a condition. Fructal morphology is quite variable within *Aethionema*, as it is throughout much of Brassicaceae, but all core taxa within *Aethionema* possess fruit with membranously winged valves. As stated before, the presence of wings is a variable trait in *A. trinervium*, which has been a principal reason for classification problems.

Taxonomists who did not accept that *Aethionema trinervium* belongs to the genus *Aethionema* placed the species in a number of other genera. Originally described as *Hutchinsia trinervia* DC. by de Candolle (1821), it was also later placed in the genera *Iberidella* Boiss. (Boissier, 1841), *Aethionema* DC. (Boissier, 1867), *Eunomia* DC. (Prantl, 1891), and *Thlaspi* L. (Mozaffarian, 1996). *Eunomia trinervia* (DC.) Prantl was recombined on the basis of the presence of median nectary glands. Schulz (1933) also later recognized *E. trinervia* in his own familial classification. This conclusion is not easy to follow because in *A. trinervium*, as in *A. salmasium* Boiss., median nectary glands are absent. However, the lateral nectaries are somewhat connected, thus possibly giving the impression of median glands. Based on some morphological and cytological characters, Mozaffarian (1996) included *A. trinervium* in *Thlaspi* as *T. trinervium* (DC.) Mozaff., and this species was also treated as *T. trinervium* in the recent species checklist of the Brassicaceae (Warwick et al., 2006b). Apparently, Mozaffarian did not recognize the main phylogenetic lineages within *Thlaspi* s.l. suggested by Meyer (1973, 1979, 1991), which are based on the analysis of seed coat anatomy and later generally supported by molecular studies (Mummenhoff & Koch, 1994; Mummenhoff et al., 1997a, b; Koch et al., 2001). Thus, it is unclear to which *Thlaspi* s.l. segregate *A. trinervium* should be assigned. Recent broadly sampled molecular studies of Brassicaceae (Khosravi, 2001; Koch et al., 2001; Beilstein et al., 2006) also proved that *Thlaspi* s.l. is a polyphyletic

taxon and that the members of *Thlaspi* s. str. are distantly related to the other *Thlaspi* s.l. lineages. In the most recent systematic treatment of the family, Al-Shehbaz et al. (2006) placed members of *Thlaspi* s. str., along with other genera (e.g., *Alliaria* Heist. ex Fabr., *Pachyphragma* Rehb., *Peltaria* Jacq.), in tribe Thlaspidaceae and remaining *Thlaspi* s.l. segregates in the tribe Noccaeeae. In summing up its taxonomic history, it is clear that *A. trinervium* has long been a poorly understood species for which previous taxonomic classification attempts have proven both vague and unstable.

Furthermore, the morphology within *Aethionema trinervium* is exceptionally variable, and some of this variation appears to show geographic structure (Davis et al., 1965). Herbarium specimens may suggest a gradual reduction in fruit valve wing size and an increase in leaf auricle size as the species ranges from west to east. In addition, four separately described taxa are often either reduced to synonymy with *A. trinervium* or treated as a variety thereof. Two of the synonymous names, *Iberidella ovalifolia* Boiss. and *I. sagittata* Boiss. (later *A. sagittatum* (Boiss.) Boiss.), were described by Boissier in 1842. They apparently differ from each other in the relative prominence of the leaf auricles. Such variation has been treated within the scope of *A. trinervium* in some floras (Hedge, 1965, 1968; Hedge & Lamond, 1980), although others distinguish between *A. trinervium* and *A. sagittatum* (Shishkin & Vasilchenko, 1948; Karjagin, 1953; Avetisian, 1966).

Furthermore, Boissier (1867) separated *Aethionema salmasium* from *A. trinervium* on the basis of fruit wing differences. However, *A. salmasium* was not accepted by Hedge (1965, 1968), apparently due to overlapping patterns of morphological variation. However, other national floras do recognize both species as distinct (Karjagin, 1953; Avetisian, 1966; Khintibidze, 1979).

Perhaps most different from typical *Aethionema trinervium* is *A. apterocarpum* Rech. f. & Aellen, which is described from material in the Iranian provinces of North Khorasan, South Khorasan, and Razavi Khorasan, where the taxon is endemic (Hedge, 1968). It was reclassified as *A. trinervium* var. *apterocarpum* (Rech. f. & Aellen) Hedge by Hedge (1968). It is characterized by wingless fruit valves that are further distinguished by the fruit shape itself being shorter and more ovate than in typical *A. trinervium*. Also, the inflorescence peduncle usually elongates earlier in floral development than typical *A. trinervium*, with each flower's pedicel separated by approximately a centimeter of peduncle length at the time of anthesis. In contrast, typical *A. trinervium* inflorescences remain as compacted racemes at

anthesis but elongate later during fruit development. The biogeographic and genetic relationships between the morphological variants of *A. trinervium* remain unclear. The problem is introduced here, but clear answers await completion of a more comprehensive population-level genetic analysis of what may potentially be a multispecies complex. Thus, the goal of this present study is to use sequence variation of the nuclear ITS of ribosomal DNA (ITS-1 and ITS-2) of *A. trinervium* and representatives of putative related genera, especially *Aethionema* and *Thlaspi* s.l. segregates, advocated generic rank by Meyer (1973, 1979, 1991), to clarify the phylogenetic position of *A. trinervium*.

MATERIALS AND METHODS

SAMPLING

In the current study, we have included representatives of *Aethionema* and *Thlaspi* s.l. along with other taxa previously shown to be closely related to *Thlaspi* s.l. (Zunk et al., 1996; Mummenhoff et al., 1997a, b; Koch & Mummenhoff, 2001). Because *Aethionema* is sister to all remaining Brassicaceae (Zunk et al., 1996, 1999; Galloway et al., 1998; Koch et al., 2001, 2003) and *A. trinervium* might be nested in *Aethionema*, *Cleome lutea* Hook., a member of the Cleomaceae (sensu Hall et al., 2002), the sister family of the Brassicaceae, was selected as the outgroup. The final data set comprised 39 taxa. ITS sequences were generated for *A. trinervium*. Other sequences were obtained from GenBank (Table 1).

DNA EXTRACTION, AMPLIFICATION, AND SEQUENCING

Total DNA was isolated from dried leaf material of *Aethionema trinervium* (IRAN. **Kerman Province:** Ravar, Sood Kuh, 5 Sep. 2004, *Mirtadzadini 24985*, voucher in Herbarium of Shiraz University) using a modified CTAB method (Aras et al., 2003). Double-stranded DNA of the complete ITS region, including the 5.8S ribosomal DNA (rDNA) gene, was amplified by 35 cycles of symmetric polymerase chain reaction (PCR) using ITS primers initially designed by White et al. (1990) and modified by Mummenhoff et al. (1997a). The PCR profile was a hot start with 5 min. at 94°C, and 35 cycles of amplification (1 min. 94°C, 1 min. 50°C, 1 min. 72°C), with final elongation for 10 min. at 72°C. PCR products were purified using the High Pure PCR Product Purification Kit (Roche Diagnostics—Applied Science, Mannheim, Germany). Sequencing reactions were run on an ABI 377XL automated sequencer (Applied Biosystems, Weiterstadt, Germany).

DATA ANALYSIS

DNA sequences were aligned with those obtained from GenBank using Clustal W version 1.8 (Thompson et al., 1994). Multiple alignment parameters were set to 12 for gap opening penalty and 0.1 for gap extensions penalty. Alignments were confirmed manually using sequential pairwise comparisons. Regions with ambiguous alignment were eliminated from phylogenetic analyses. The alignment is available from the first author. Maximum parsimony analyses of the aligned sequences of the ITS data set were conducted using the computer program PAUP*, version 4.0b10 (Swofford, 2000). The most parsimonious trees were generated using the heuristic search method, with tree bisection-reconnection (TBR) branch swapping, equal-weighted characters, 1000 random additions of the sampled taxa, and 100 trees saved per replicate. Sets of equally most parsimonious trees were summarized by a strict consensus tree. Bootstrap tests (Felsenstein, 1985) were performed using 500 replicates with heuristic search settings identical to those of the original search. Pairwise distance sequence divergence of ITS was calculated for each accession pair in PAUP* using the Kimura two-parameter model (Kimura, 1980).

RESULTS

The aligned data matrix contained 403 positions after removing regions with alignment ambiguities. Of these, 188 (46.6%) were potentially phylogenetically informative, 126 (31.3%) were invariant, and 89 sites (22.1%) were autapomorphic. The heuristic search resulted in 126 most parsimonious trees of 718 steps with a consistency index of 0.5615. The results of the phylogenetic analysis are shown in Figure 1. Two major clades can be recognized on the strict consensus tree (Fig. 1). The first lineage (referred to here as *Thlaspi* clade) comprises all the species traditionally subsumed under *Thlaspi* s.l. along with other genera recently shown to be closely related to *Thlaspi* s.l. (Mummenhoff & Koch, 1994; Mummenhoff et al., 1997a, b; Koch & Mummenhoff, 2001; Koch & Al-Shehbaz, 2004). Most representatives of this lineage belong to tribes Noccaeeae and Thlaspi-deae. Also, *Aethionema trinervium* clearly belongs here, and it is found in a strongly supported clade (100% bootstrap support) along with *Vania campylophylla* F. K. Mey. and *V. kurdica* (Hedge) F. K. Mey. in the tribe Noccaeeae. The second lineage represents the genus *Aethionema* and is referred to here as the *Aethionema* clade (tribe Aethionemeae). The genetic divergence between these two main clades is

Table 1. List of taxa used for the current study.

Taxon	Source	GenBank accession number
<i>Aethionema arabicum</i> (L.) Andr. ex DC.	Hong et al., 2003	AY254539
<i>A. elongatum</i> Boiss.	Koch et al., unpublished	DQ518386
<i>A. grandiflorum</i> Boiss. & Hohen.	Bailey et al., 2006	DQ452067
<i>A. saxatile</i> (L.) R. Br.	Mummenhoff et al., 2005	AJ862697
<i>A. trinervium</i> Boiss.	Present study	FM180111
<i>Alliaria petiolata</i> (M. Bieb.) Cavara & Grande	Mummenhoff et al., 2005	AJ862703/AJ862704
<i>Cleome lutea</i> Hook.	O'Kane & Al-Shehbaz, 2003	AF137588
<i>Cochlearia aucheri</i> Boiss.	Koch & Mummenhoff, 2001	AF336202/AF336203
<i>C. megalosperma</i> (Maire) R. Vogt	Koch & Mummenhoff, 2001	AF336208/AF336209
<i>C. sempervivum</i> Boiss. & Balansa	Peer et al., 2003	AY261529
<i>C. sintenisii</i> Hausskn. ex Bornm.	Koch & Mummenhoff, 2001	AF336204/AF336205
<i>Peltaria turkmena</i> Lipsky	Koch & Mummenhoff, 2001	AF336212/AF336213
<i>Teesdalia nudicaulis</i> (L.) R. Br.	Koch & Mummenhoff, 2001	AF336214/AF336215
<i>Thlaspi alliaceum</i> L.	Koch & Mummenhoff, 2001	AF336156/AF336157
<i>T. alpinum</i> Crantz	Koch & Al-Shehbaz, 2004	AY154812
<i>T. arvense</i> L.	Koch & Mummenhoff, 2001	AF336152/AF336153
<i>T. bulbosum</i> Boiss.	Koch & Mummenhoff, 2001	AF336200/AF336201
<i>T. caerulescens</i> J. Presl & C. Presl	Koch & Mummenhoff, 2001	AF336188/AF336189
<i>T. calaminare</i> Lej. & Courtois	Koch & Mummenhoff, 2001	AF336192/AF336193
<i>T. cepaeifolium</i> (Wulfen) W. D. J. Koch	Koch & Al-Shehbaz, 2004	AF336198/AF336199
<i>T. ceratocarpum</i> N. Busch	Koch & Mummenhoff, 2001	AF336154/AF336155
<i>T. cilicicum</i> (Schott & Kotschy) Hayek	Koch & Mummenhoff, 2001	AF336166/AF336167
<i>T. crassiusculum</i> (F. K. Mey.) Greuter & Burdet	Koch & Mummenhoff, 2001	AF336206/AF336207
<i>T. densiflorum</i> Boiss. & Kotschy	Koch & Al-Shehbaz, 2004	AY154816
<i>T. elegans</i> Boiss.	Koch & Mummenhoff, 2001	AF336160/AF336161
<i>T. goesingense</i> Halácsy	Peer et al., 2003	AY261528
<i>T. granatense</i> Boiss. & Reut.	Koch & Mummenhoff, 2001	AF336176/AF336177
<i>T. hastulatum</i> Steven ex DC.	Koch & Mummenhoff, 2001	AF336164/AF336165
<i>T. jankae</i> A. Kern.	Koch & Al-Shehbaz, 2004	AY154817
<i>T. lilacinum</i> Boiss. & A. Huet	Koch & Mummenhoff, 2001	AF336162/AF336163
<i>T. macranthum</i> N. Busch	Koch & Mummenhoff, 2001	AF336194 /AF336195
<i>T. montanum</i> L.	Koch & Mummenhoff, 2001	AF336196/AF336197
<i>T. natolicum</i> Boiss.	Koch & Mummenhoff, 2001	AF336184/AF336185
<i>T. orbiculatum</i> Steven ex DC.	Koch & Mummenhoff, 2001	AF336172/AF336173
<i>T. oxyceras</i> (Boiss.) Hedge	Koch & Mummenhoff, 2001	AF336158/AF336159
<i>T. perfoliatum</i> L.	Koch & Mummenhoff, 2001	AF336180/AF336181
<i>T. szowitsianum</i> Boiss.	Koch & Mummenhoff, 2001	AF336174/AF336175
<i>T. umbellatum</i> Steven ex DC.	Koch & Mummenhoff, 2001	AF336186/AF336187
<i>Vania campylophylla</i> F. K. Mey.	Koch & Mummenhoff, 2001	AF336168/AF336169
<i>V. kurdica</i> (Hedge) F. K. Mey.	Koch & Mummenhoff, 2001	AF336170/AF336171

considerably high. ITS sequence divergence between *A. trinervium* and other *Aethionema* species ranges between 34.5% (*A. trinervium* vs. *A. elongatum* Boiss.) and 39.5% (*A. trinervium* vs. *A. grandiflorum* Boiss. & Hohen.). On the other hand, the sequence divergence between *A. trinervium* and *Thlaspi* s.l. species is significantly lower and ranges between 2% (*A. trinervium* vs. *V. campylophylla*) and 21.5% (*A. trinervium* vs. *T. hastulatum* (Steven ex DC.) Hedge). This is additional evidence that *A. trinervium* is more closely related to *Thlaspi* s.l. taxa than to *Aethionema*.

DISCUSSION

In the current study, we used evidence from nuclear ITS sequences to clarify the generic status and phylogenetic relationships of *Aethionema trinervium*, a species variously assigned to different genera in different traditional classifications (e.g., *Hutchinsia* R. Br., de Candolle, 1821; *Iberidella*, Boissier, 1841; *Aethionema*, Boissier, 1867; *Eunomia*, Prantl, 1891; *Thlaspi* s.l., Mozaffarian, 1996). These genera are all taxonomically critical, but for a better understanding

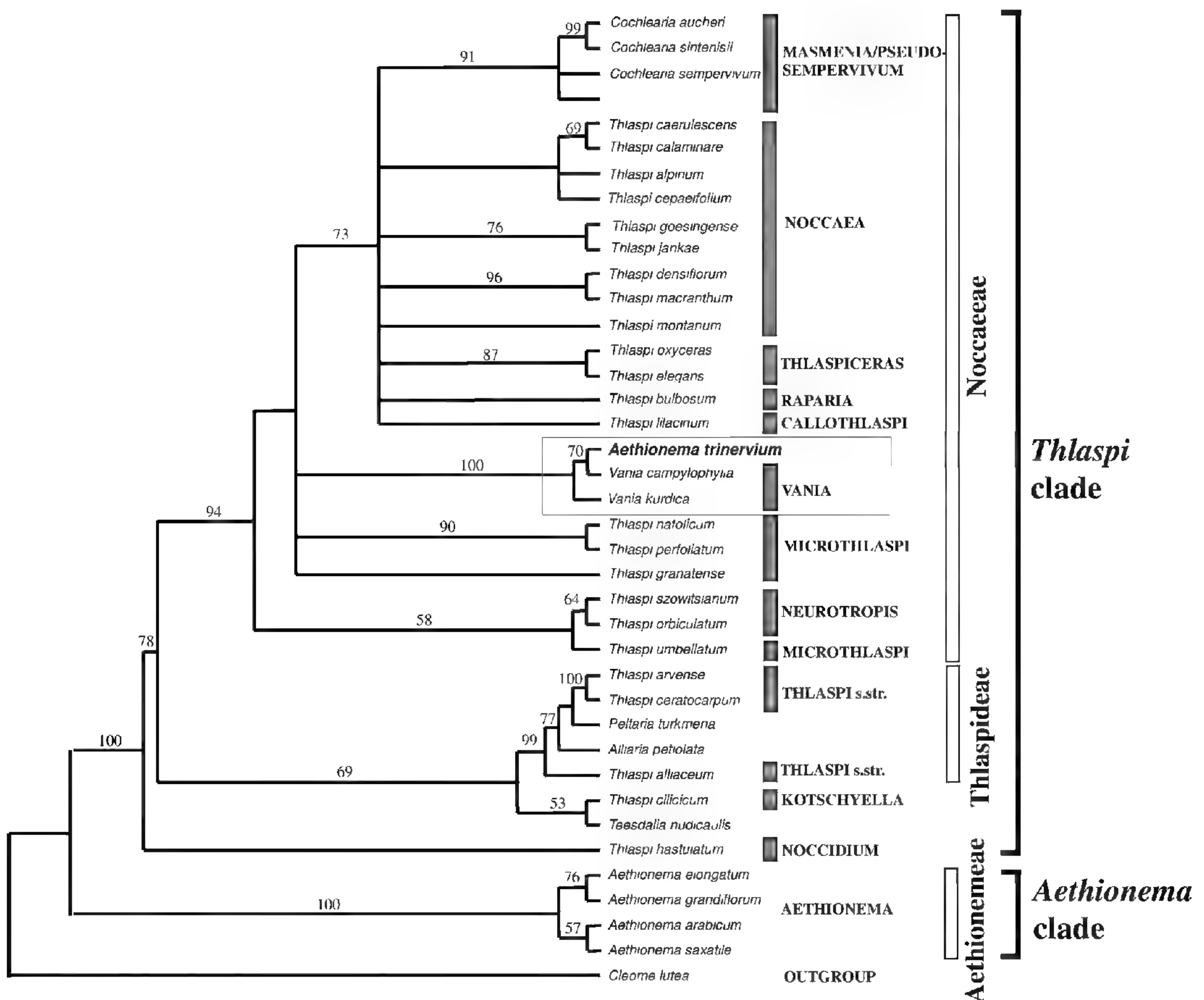

Figure 1. Strict consensus tree of 126 most parsimonious Fitch trees (tree length – 718 steps). Bootstrap values more than 50% are indicated above branches. Generic grouping by Meyer (1973, 1979, 1991) is indicated by grey vertical bars. *Alliaria petiolata* (M. Bieb.) Cavara & Grande and *Peltaria turkmena* Lipsky were not recognized by Meyer as *Thlaspi* s. str. (Koch et al., 2001; Mummenhoff et al., 2001). Tribal grouping by Al-Shehbaz et al. (2006) is indicated by white bars.

of the phylogenetic discussion, these taxa need some closer inspection.

Meyer (1973, 1979) divided *Thlaspi* s.l. into 12 segregate genera based primarily on differences in seed sculpture and seed-coat anatomy in contrast to morphological fruit characters prone to homoplasy and used in traditional treatments (see Meyer, 1991; Mummenhoff et al., 1997b; Koch & Mummenhoff, 2001; Meyer et al., 2001a). The status of these segregates varied from complete rejection (Greuter et al., 1986) to partial acceptance (Al-Shehbaz, 2002) to complete acceptance (Czerepanov, 1995). *Thlaspi* s.l. has been subjected to extensive molecular studies to test the validity of Meyer's (1973, 1979, 1991, 2001a, b) segregates. Recently, Koch and Mummenhoff (2001) summarized a decade of phylogenetic studies on *Thlaspi* and pointed out that, with the exception of certain segregates (e.g., *Microthlaspi* F. K. Mey.), most of Meyer's segregates represent monophyletic groups supported by molecular data. Furthermore, species

previously placed in *Cochlearia* L. sect. *Pseudosempervivum* Boiss. (e.g., *C. sempervivum* Boiss. & Balansa, *C. aucheri* Boiss., *C. sintenisii* Hausskn. ex Bornm.) are nested within *Thlaspi* s.l. and are better treated either as *Masmenia* F. K. Mey. or *Pseudosempervivum* (Boiss.) Grossh. (Fig. 1). Finally, *Thlaspi* s. str. is more closely related to *Peltaria*, *Alliaria*, and *Thlaspi* s.l. segregates *Noccidium* F. K. Mey. and *Kotschyella* F. K. Mey. than to any other of Meyer's segregates of *Thlaspi* s.l. (Fig. 1). Except for *Thlaspi* s. str., *Noccidium*, and *Kotschyella*, the other *Thlaspi* s.l. segregates of Meyer (1973, 1979) group with *Noocaea* Moench in a well-supported clade. It was suggested by Al-Shehbaz et al. (2006) that only a few of Meyer's segregates might deserve recognition (Fig. 1); these include *Thlaspi* s. str., *Neurotropis* (DC.) F. K. Mey., and only part of *Microthlaspi*, and the remaining segregates should perhaps best be treated as synonyms of *Noocaea* (Al-Shehbaz et al., 2006). However, our data also indicate that *Vania* F. K. Mey. might

Table 2. Distribution of morphological and cytological data in *Aethionema*, *A. trinervium*, *Thlaspi* s. str., *Vania*, and *Noccaea*.

Character	<i>Aethionema</i>	<i>A. trinervium</i>	<i>Thlaspi</i> s. str.	<i>Vania</i>	<i>Noccaea</i>
Habit	annual or perennial	perennial	annual	perennial	perennial
Basal leaves	not rosulate	subrosulate	not rosulate	subrosulate	rosulate or subrosulate
Basal leaf shape	sessile, linear or oblong	oblong or subulate	spatulate or oblanceolate	oblong or subulate	spatulate
Stem leaf shape	linear, oblong, or ovate	oblong, ovate, or linear-lanceolate	oblong or lanceolate	oblong, ovate, or linear-lanceolate	broad ovate, ovate, or oblong
Base of stem leaf blades	very rarely auriculate	exauriculate or + auriculate	auriculate	exauriculate or + auriculate	auriculate or exauriculate
Leaf attachment to stem	very rarely amplexicaul	amplexicaul	amplexicaul or sagittate	amplexicaul	amplexicaul or sagittate
Sepals	+ bisaccate	not saccate	not saccate	not saccate	not saccate
No. of veins on petal claws	3	1	1	1	1
Anthers	apiculate or not apiculate	apiculate	not apiculate	apiculate	not apiculate
Shape of lateral nectaries	semiglobose	crescent	crescent	crescent	crescent
Seed surface	smooth or minutely papillose	smooth	striate or reticulate	smooth	smooth
Seed mucilage	present or absent	absent	absent	absent	absent or slightly present
Base chromosome number	mostly x = 11, 12	x = 7	x = 7	x = 7	x = 7

deserve recognition because this lineage is well separated from the core *Noccaea* group consisting of *Masmenia/Pseudosempervivum*, *Noccaea* s. str., *Thlaspiceras* F. K. Mey., *Raparia* F. K. Mey., and *Callothlaspi* F. K. Mey. (Fig. 1). In the most recent systematic treatment of the family, Al-Shehbaz et al. (2006) placed the members of *Thlaspi* s. str. in tribe Thlaspideae and the remaining *Thlaspi* s.l. lineages in tribe Noccaeeae. The primary difference between the Thlaspideae and Noccaeeae is the presence of striate or coarsely reticulate seeds and often palmately veined basal leaves in the former tribe.

The genus *Aethionema* comprises approximately 60 species and shows tremendous variation in habit (annual herbs to shrubs), floral structure (filaments with or without appendages), floral color, fruit morphology, and base chromosome numbers ($n = 7, 8, 11, 12, 14, 16, 18, 21, 22, 24, 30$; Appel & Al-Shehbaz, 2003). *Aethionema* was long thought to be closely related to *Thlaspi* s.l. (Schulz, 1936; Al-Shehbaz, 1986), but molecular data clearly demonstrate that *Aethionema* is distantly related to *Thlaspi* s.l. and instead is sister to the rest of the Brassicaceae (Koch et al., 2003; Al-Shehbaz et al., 2006, and references therein). Khosravi (1989) recognized two unrelated groups of *Aethionema* species, one group with one nerve on the petal's claw, half moon-like lateral nectar glands, and a base chromosome number of $x = 7$. These taxa were previously assigned to *Eunomia* (e.g., *Aethionema iberidium* (Boiss.) Boiss. – *Eunomia iberidea* Boiss., *A. oppositifolium* Boiss. – *E. oppositifolia* DC., *A. rotundifolium* Boiss. = *E. rotundifolia* C. A. Mey., *A. caespitosum* (Boiss.) Boiss. – *E. caespitosa* (Boiss.) O. E. Schulz, and *A. trinervium* (DC.) Boiss. = *E. trinervia* (DC.) Prantl). The second group, the *Aethionema* core group (including remaining *Aethionema* species and *Moriera* Boiss.), is characterized by three nerves on the claw, semiglobose lateral nectaries, and a base chromosome number of $x = 11, 12$ (Table 2). This group belongs to tribe Aethionemeae. An in-depth phylogenetic analysis of the tribe Aethionemeae is currently being investigated by one of the authors (M.M.).

The genus *Eunomia* has been most recently treated as a synonym of *Aethionema* (Appel & Al-Shehbaz, 2003) or *Iberis* L. (Hall et al., 2002), but the latter phylogenetic analysis demonstrated that *I. oppositifolia* Pers. (= *Eunomia oppositifolia*) is neither related to *Aethionema grandiflorum* nor *I. amara* L. Therefore, it remains unclear if *Eunomia* should be recognized as an independent genus. Recent *ndhF* and *trnL-F* data (Khosravi, unpublished data; Menke, unpublished data) provided evidence that *E. oppositifolia* is a close relative of *Noccaea*. Summing up, the systematic position of *Eunomia* needs to be resolved,

as does the taxonomic placement of the ca. 16 species previously assigned to it.

Our molecular study clearly shows that *Aethionema trinervium* is outside the *Aethionema* clade and is instead well nested in the *Thlaspi* clade (Fig. 1). *Aethionema trinervium* is placed with 100% bootstrap support into a lineage along with *Vania kurdica* and *V. campylophylla*. *Vania* is one of the 12 segregate genera defined by Meyer (1991). Members of the *Vania* lineage are xeromorphic, cushion-forming plants growing at altitudes between 3000 and 4000 m. Detailed morphological examination of *A. trinervium* demonstrates that it is very similar to the typical representatives of the *Vania* lineage (for a description, see Meyer, 2006). *Vania* species have a pulvinate or subpulvinate habit and simple glabrous stems. The basal leaves are spatulate, entire, and show a firm texture, while the stem leaves are amplexicaul or sessile, oblong or oblong-lanceolate, the flowers have white petals and apiculate anthers, the fruits are oblong or obcordate, wingless or almost wingless, and the seeds are smooth and not mucilaginous. The base chromosome number is $x = 7$. Meyer (1973) described three species of *Vania*: *V. campylophylla*, *V. kurdica*, and *V. pulvinata* F. K. Mey. All *Vania* species and *A. trinervium* have a connective tooth at the top of the anther never seen in *Noccaea*.

NOMENCLATURE AND TYPIFICATION

Morphological and molecular data strongly support the transfer of *Aethionema trinervium* to *Vania*, and we propose the following new combination:

Vania trinervia (DC.) Khosravi, Jacquemoud, Menke, Mumm. & Mohsenz., comb. nov. Basionym: *Hutchinsia trinervia* DC., Reg. Veg. Syst. Nat. 2: 387. 1821. TYPE: [Iran. Alwand Kuh:] "Hab. in Persiae monte Elwind. Michaux. Olivier," *herb. Olivier 1822* (lectotype, designated here, G-DC!). Figure 2.

There is a handwritten label on the lectotype, with the following detail: "*Hutchinsia trinervia* [scripsit A.-P. DC.] / *Mont evlind* [sic, scripsit Olivier?] / *herb. Olivier 1822* [scripsit x, non A.-P. DC.]" The lectotype is the plant specimen attached to that label, on the right side of the sheet (see Fig. 2, barcode G00131229). It should be noted that the "1822" annotation represents the year of accession by de Candolle, not a date of gathering. Additionally, there is an isoelectotype, a single sheet and single specimen, at Paris (P 00633350 photo!) with the following handwritten label: "*Hutchinsia trinervia* DC. [scripsit A.-P. DC.] / *Iberidella trinervia* Boiss. / *Aethionema*—*Bss. Fl. Or.* [scripsit x] / *Amadan.* / *Mont Elvind.* /

Olivier et Bruguère [scripsit y]." An annotation label by A.-P. de Candolle, "*Hutchinsia trinervia* DC.," also appears on the isoelectotype sheet.

Three syntypes were also known to us for consideration. The first specimen (G-DC!, 1: 178, n.6; barcode G 00131230, one sheet with one specimen) carries a handwritten label: "*Iberis* / *Perse* [scripsit x]." A small envelope containing a dissected flower is attached to this sheet and is annotated by de Candolle "*petala aequalia* / *an Lepia?*" This was part of the original collection by Michaux, and this syntype is mounted on the same physical sheet as our designated lectotype, on the left part (see Fig. 2). The second candidate syntype at P (P 006633349, P photo!, one sheet with two specimens) bears a handwritten label: "*Hutchinsia trinervia* DC. [scripsit A.-P. DC.] / *Iberidella trinervia* Boiss. / *Aethionem*—*Bss. Fl. Or.* [scripsit x] / *Perse. Michaux* [scripsit y]." Finally, a third candidate syntype was examined (G!, ex hb. Delessert, one sheet with one specimen), which is represented by plate 2, tab. 53, in Delessert's *Icones selectae plantarum* (Delessert, 1824: 16). This third syntype has the handwritten label: "*Hutchinsia trinervia* DC. [scripsit x] / *Aethionema trinervium* Boiss. / *J. Briquet 1912* [scripsit Briquet] / *Michaux (Herb. De Perse)* [scripsit y]." The G syntype has an annotation label glued on the first, which states "*Thlaspi* / *trinervatum* [scripsit ?] / *Hutchinsia trinervia* DC. [scripsit A.-P. DC.]"

There is no doubt that Michaux was the first botanist who collected *Hutchinsia trinervia*. However, the taxon was already considered morphologically variable by Boissier (1842: 188–189), who regarded it as a representative of the genus *Aethionema* in his treatment of Cruciferae (Boissier, 1867: 341–343). Therefore, because further taxonomic research may perhaps lead to division of *A. trinervium* s.l. into different taxa, the exact geographic origin of the lectotype needs special attention. Thus, preference was given to the collections by Olivier and Bruguère where the label indications clearly fit the protologue locality (de Candolle, 1821: 387). Moreover, the Olivier and Bruguère specimens not only bear flowers, but also young fruits. Although immature, these fruits enabled de Candolle to resolve the unsatisfactory floral dissection made on a Michaux collection ("an *Lepia?*" written on the envelope, see above) and to describe a new species of the genus *Hutchinsia*. Further, the iconograph of *Hutchinsia trinervia* by the French illustrator J. F. Turpin was one of the many (ca. 500) engravings published in *Icones selectae plantarum* (Delessert, 1824: 16, tab. 53) (Fig. 3) with descriptions by de Candolle.

Nevertheless, we attempted to find more information about the Persian travels of Michaux, as well as of his

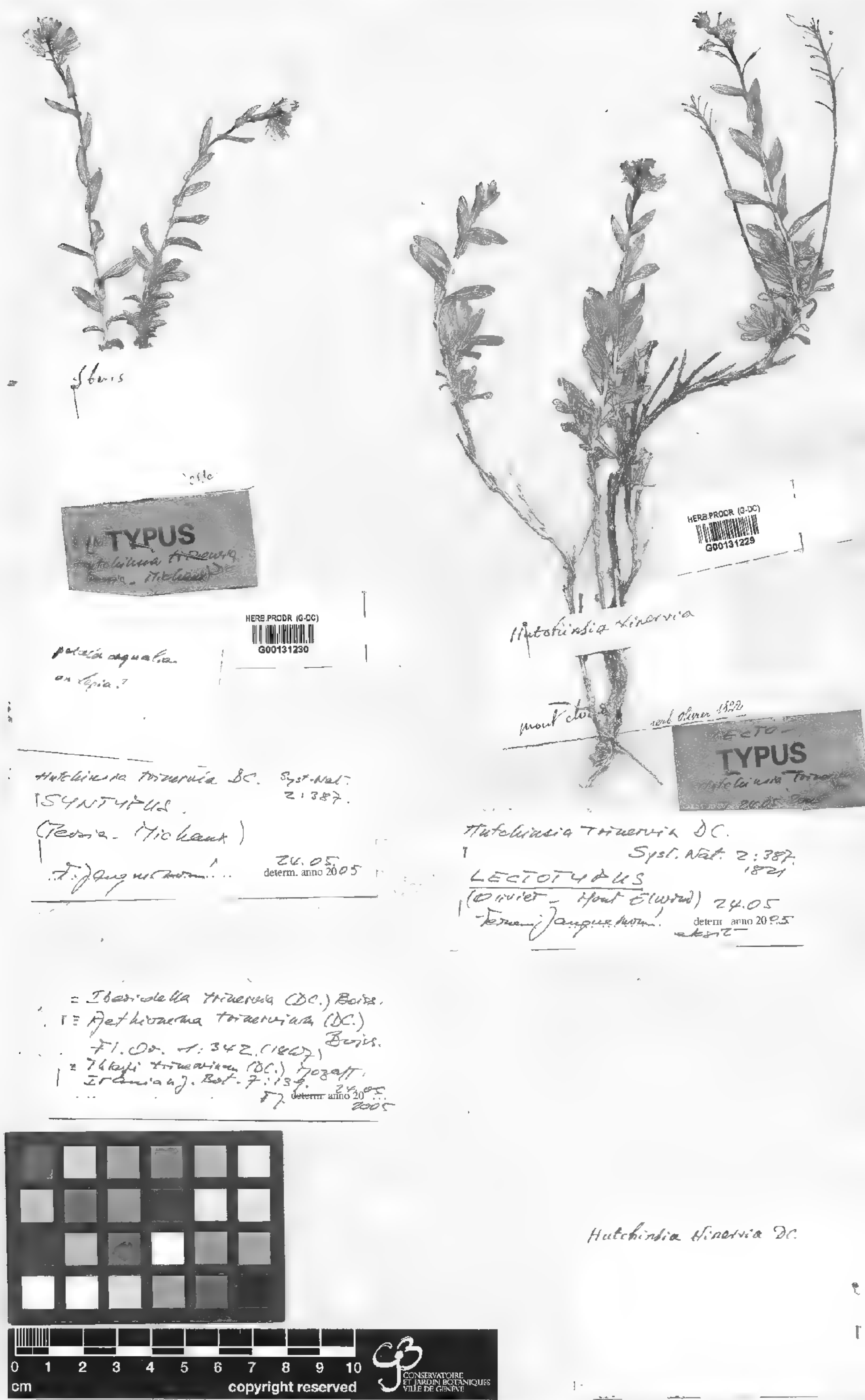
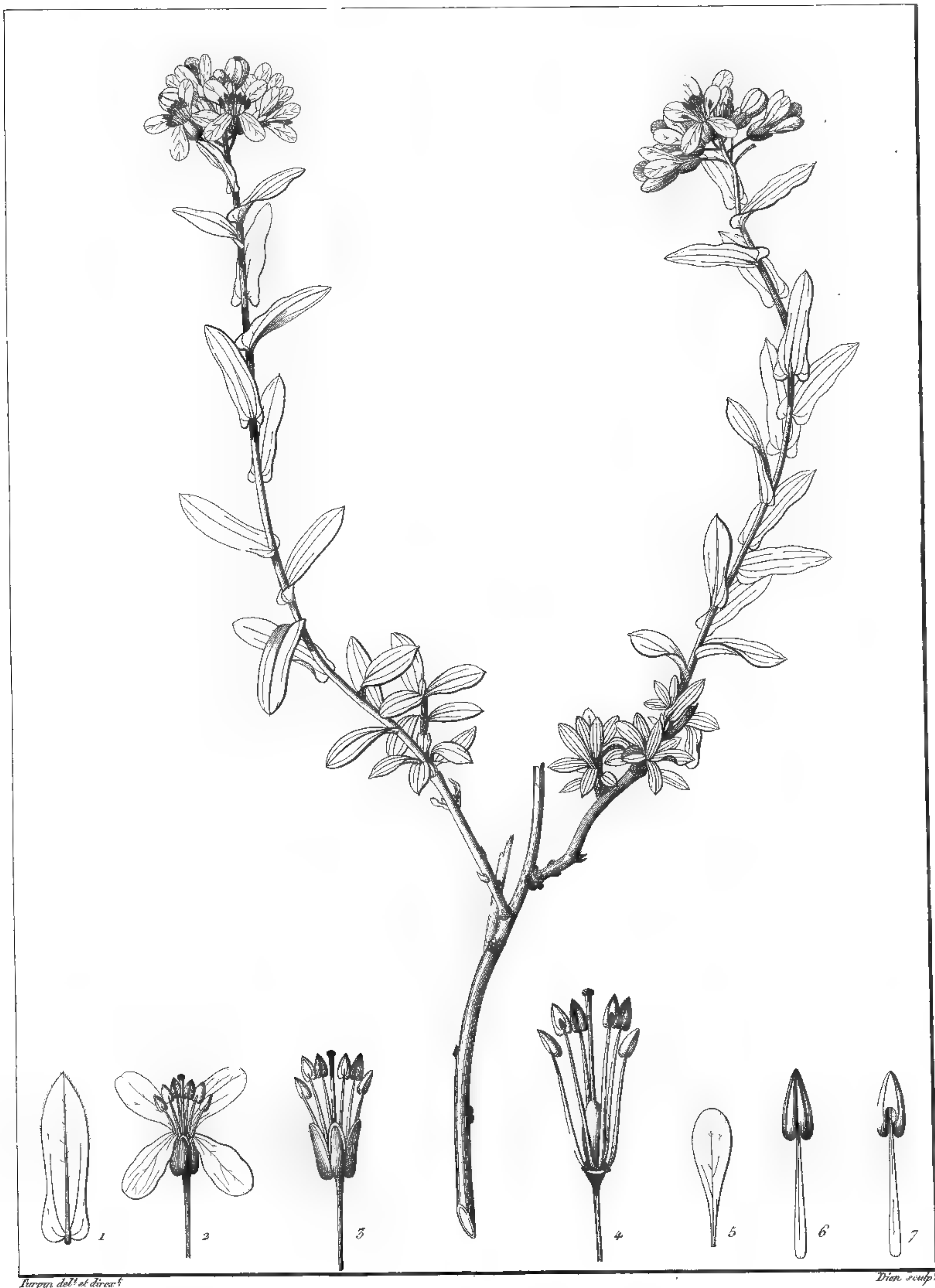

Figure 2. Lectotype specimen for *Vania trinervia* (DC.) Khosravi, Jacquemoud, Menke, Mumm. & Mohsenz. (herb. Olivier 1822, G-DC). Photo courtesy of Conservatoire botanique de la Ville de Genève.

DICOTYLEDONEÆ.

Cruciferae.

Tab. 55.



HUTCHINSIA trinervia. (DC.)
(DC. *Regn. veg.* vol. 2. pag. 387.)

Figure 3. Engraving of the analytic illustration of *Hutchinsia trinervia* DC. by Turpin, in *Icones selectae plantarum* edited by Benjamin Delessert, with descriptions by A.-P. de Candolle. —1. Cauline leaf. —2. Flower. —3. Calyx with ovary and stamens. —4. Ovary and stamens. —5. Petal. —6. Stamen (internal view). —7. Stamen (external view). Courtesy of the Library, Conservatoire botanique de la Ville de Genève.

journey at Hamadan and collecting foray on "Mont Elvind" [Alwand Kuh]. However, neither Deleuze (1804: 198), the first biographer of Michaux, Sargent (1889: 3), or Boissier (1867: xxvi) provide any relevant

information. More accurate data are found in Jaubert and Spach (1842–1843), since the book includes a map with the itineraries of the first botanical collectors in the Middle East. Particularly interesting are details of

Michaux's Persian itinerary, which were found in handwritten notes held by Delessert. It is unclear why no further information is available in Jaubert and Spach's discussion of Michaux. Furthermore, the absolute lack of reference to these notes by Lasègue (1845: 61), whose close familiarity with Delessert's herbarium, library, and archives is well known, is difficult to understand. Consequently, it is only known that Michaux traveled in Iran from 1783 to 1785 and went to Hamadan (according to the map in Jaubert & Spach [1842–1843]), certainly crossing part of the Alwand Kuh, likely on a similar route followed by Olivier and Bruguère about 10 years later in 1796–1797 (Boissier, 1867: xxvi). Finally, it should be noted that although Aucher-Eloy (1843) botanized twice on "Elwend" (25 and 29 May 1835) and provided a detailed report of his expedition, he does not refer to his compatriots Michaux, Olivier, or Bruguère, nor does he mention *Hutchinsia trinervia* (or *Aethionema trinervium*).

Literature Cited

- Al-Shehbaz, I. A. 1986. The genera of Lepidieae (Cruciferae, Brassicaceae) in the southeastern United States. *J. Arnold Arbor.* 67: 265–311.
- . 2002. *Noccaea nepalensis*, a new species from Nepal, and four new combinations in *Noccaea* (Brassicaceae). *Adansonia* 24: 89–92.
- , M. A. Beilstein & E. A. Kellogg. 2006. Systematics and phylogeny of the Brassicaceae (Cruciferae): An overview. *Pl. Syst. Evol.* 259: 89–120.
- Appel, O. & I. A. Al-Shehbaz. 2003. Cruciferae. Pp. 75–174 in K. Kubitzki (editor), *Families and Genera of Vascular Plants*. Springer-Verlag, Berlin.
- Aras, S., A. Duran & G. Yenilmez. 2003. Isolation of DNA for RAPD analysis from dry leaf material of some *Hesperis* L. specimens. *Pl. Molec. Biol. Rep.* 21: 461a–461f.
- Aucher-Eloy, P. M. R. 1843. *Relations de Voyages en Orient de 1830 à 1838*. Première partie. Roret, Paris.
- Avetisian, V. 1966. Brassicaceae (*Aethionema*). Pp. 255–269 in A. Takhtajan (editor), *Flora of Armenia*, Vol. V. Nauka, Moscow.
- Bailey, C. D., M. A. Koch, M. Mayer, K. Mummenhoff, S. L. O'Kane, S. I. Warwick, M. D. Windham & I. A. Al-Shehbaz. 2006. Towards a global nrDNA ITS phylogeny of the Brassicaceae. *Mol. Biol. Evol.* 23: 2142–2160.
- Beilstein, M. A., I. A. Al-Shehbaz & E. A. Kellogg. 2006. Brassicaceae phylogeny and trichome evolution. *Amer. J. Bot.* 93: 607–619.
- Boissier, E. 1841. *Nova Genera Cruciferarum*. *Ann. Sci. Nat., Bot. sér.* 2 16: 378–382.
- . 1842. *Plantae Aucherianae Orientales*. *Ann. Sci. Nat. Bot., sér.* 2 17: 150–205.
- . 1867. *Flora Orientalis*, Vol. 1. H. Georg, Basel.
- Candolle, A.-P. de. 1821. *Regni Vegetabilis Systema Naturale*, Vol. 2. Treuttel & Würtz, Paris.
- Crawford, D. J., R. T. Kimball & M. Tadesse. 2001. The generic placement of a morphologically enigmatic species in Asteraceae: Evidence from ITS sequences. *Pl. Syst. Evol.* 228: 63–69.
- Czerepanov, S. K. 1995. *Vascular Plants of Russia and Adjacent States (the Former USSR)*. Oxford University Press, Oxford.
- Davis, P. H., J. Cullen, M. J. E. Coode & I. C. Hedge. 1965. Materials for a flora of Turkey: X. *Notes Roy. Bot. Gard. Edinburgh* 26: 165–201.
- Delessert, B. 1824 [1823]. *Icones Selectae Plantarum*, Vol. 2. Paris.
- Deleuze, J. P. F. 1804. Notice historique sur André Michaux. *Ann. Mus. Natl. Hist. Nat.* 3: 191–227.
- Felsenstein, J. 1985. Confidence limits on phylogenies: An approach using the bootstrap. *Evolution* 39: 783–791.
- Galloway, G. L., R. L. Malmberg & R. A. Price. 1998. Phylogenetic utility of the nuclear gene arginine decarboxylase: An example from Brassicaceae. *Molec. Biol. Evol.* 15: 1312–1320.
- Greuter, W., H. M. Burdet & G. Long (editors). 1986. *Med-checklist, Dicotyledones*. Conservatoire et Jardin Botaniques de la Ville de Genève, Genève.
- Hall, J. C., K. J. Sytsma & H. H. Iltis. 2002. Phylogeny of Capparaceae and Brassicaceae based on chloroplast sequence data. *Amer. J. Bot.* 89: 1826–1842.
- Hedge, I. C. 1965. *Aethionema*. Pp. 314–330 in P. H. Davis, I. Cullen & M. J. E. Coode (editors), *Flora of Turkey and the East Aegean Islands*, Vol. 1. Edinburgh University Press, Edinburgh.
- . 1968. *Aethionema*. Pp. 102–110 in K. H. Rechinger (editor), *Flora Iranica* No. 57. Akademische Druck- u. Verlagsanstalt Graz, Graz.
- & J. M. Lamond. 1980. Cruciferae (*Aethionema*). Pp. 915–922 in C. C. Townsend & E. Guest (editors), *Flora of Iraq*, Vol. 4, Part 2. Ministry of Agriculture & Agrarian Reform, Baghdad.
- Hong, R. L., L. Hamaguchi, M. A. Busch & D. Weigel. 2003. Regulatory elements of the floral homeotic gene AGAMOUS by phylogenetic footprinting and shadowing. *Pl. Cell.* 15: 1296–1309.
- Jaubert, H. F. & E. Spach. 1842–1843. *Illustrationes Plantarum Orientalium*, Vol. 1. Roret, Paris.
- Karjagin, J. J. 1953. *Aethionema*. Pp. 169–182 in J. J. Karjagin (editor), *Flora Azerbaijan*, Vol. IV. Ministry of Culture, Baku, Azerbaijan.
- Khintibidze, L. 1979. *Aethionema*. Pp. 204–209 in N. N. Ketskhoveli (editor), *Flora of Georgia*, Vol. V. Metsnier-eba, Tbilisi, Georgia.
- Khosravi, A. R. 1989. *Cytotaxonomy and Phylogeny of the Cruciferae*. MSc. Dissertation, Tarbiat Modarres University, Tehran.
- . 2001. Comparative Restriction Site Mapping of Chloroplast Genome Implies New and Novel Phylogenetic Relationships Within Cruciferae. Ph.D. Dissertation, Delhi University, New Delhi.
- Kimura, M. 1980. A simple method for estimating evolutionary rates of base substitutions through comparative studies of nucleotide sequences. *J. Molec. Evol.* 16: 111–120.
- Koch, M. & K. Mummenhoff. 2001. *Thlaspi* s.str. (Brassicaceae) versus *Thlaspi* s.l.: Morphological and anatomical characters in the light of ITS nrDNA sequence data. *Pl. Syst. Evol.* 227: 209–225.
- & I. A. Al-Shehbaz. 2004. Taxonomic and phylogenetic evaluation of the American '*Thlaspi*' species: Identity and relationship to the Eurasian genus *Noccaea* (Brassicaceae). *Syst. Bot.* 29: 375–384.
- , B. Haubold & T. Mitchell-Olds. 2001. Molecular systematics of the Cruciferae: Evidence from coding plastidic *matK* and nuclear *Chs* sequences. *Amer. J. Bot.* 88: 534–544.

- , I. A. Al-Shehbaz & K. Mummenhoff. 2003. Molecular systematics, evolution, and population biology in the mustard family (Brassicaceae). *Ann. Missouri Bot. Gard.* 90: 151–171.
- Lasègue, A. 1845. *Musée botanique de M. Benjamin Delessert*. Fortin, Masson & Cie, Paris.
- Meyer, F. K. 1973. *Conspectus der "Thlaspi"—Arten Europas, Afrikas und Vorderasiens*. Feddes Repert. 84: 449–470.
- . 1979. *Kritische Revision der "Thlaspi"—Arten Europas, Afrikas und Vorderasiens*. Feddes Repert. 90: 129–154.
- . 1991. Seed-coat anatomy as a character for a new classification of *Thlaspi*. *Flora Veg. Mundi* 9: 9–15.
- . 2001a. *Kritische Revision der "Thlaspi"—Arten Europas, Afrikas und Vorderasiens*. Spezieller Teil. 1. *Thlaspi* L. *Haussknechtia* 8: 3–42.
- . 2001b. *Kritische Revision der "Thlaspi"—Arten Europas, Afrikas und Vorderasiens*. Spezieller Teil. 2. *Neurotropis* (DC.) F. K. Mey. *Haussknechtia* 8: 43–58.
- . 2006. *Kritische Revision der "Thlaspi"—Arten Europas, Afrikas und Vorderasiens*, Teil 11. *Haussknechtia* 11: 217–228.
- Mozaffarian, V. 1996. Studies of the flora of Iran, new species, new combination and new records. *Iranian J. Bot.* 1: 127–142.
- Mummenhoff, K. & M. Koch. 1994. Chloroplast DNA restriction site variation and phylogenetic relationships in the genus *Thlaspi* sensu lato (Brassicaceae). *Syst. Bot.* 19: 73–88.
- , A. Franzke & M. Koch. 1997a. Molecular phylogenetics of *Thlaspi* s.l. (Brassicaceae) based on chloroplast DNA restriction site variation and sequences of the internal transcribed spacers of nuclear ribosomal DNA. *Canad. J. Bot.* 75: 469–482.
- , ——— & ———. 1997b. Molecular data reveal convergence in fruit characters used in the classification of *Thlaspi* s.l. (Brassicaceae). *Bot. J. Linn. Soc.* 125: 183–199.
- , U. Coja & H. Brüggemann. 2001. *Pachyphragma* and *Gagria* (Brassicaceae) revisited: Molecular data indicate close relationship to *Thlaspi* s.str. *Folia Geobot.* 36: 293–302.
- , I. A. Al-Shehbaz, F. T. Bakker, H. P. Linder & A. Mühlhausen. 2005. Phylogeny, morphological evolution, and speciation of endemic Brassicaceae genera in the Cape Flora of southern Africa. *Ann. Missouri Bot. Gard.* 92: 400–424.
- O'Kane, S. L. & I. A. Al-Shehbaz. 2003. Phylogenetic position and generic limits of *Arabidopsis* (Brassicaceae) based on sequences of nuclear ribosomal DNA. *Ann. Missouri Bot. Gard.* 90: 603–612.
- Peer, W. A., M. Mamoudian, B. Lahner, R. D. Reeves, A. S. Murphy & D. E. Salt. 2003. Identifying model metal hyperaccumulating plants: Germplasm analysis of 20 Brassicaceae accessions from a wide geographical area. *New Phytol.* 159: 421–430.
- Prantl, K. 1891. *Eunomia*. P. 165 in A. Engler & K. Prantl (editors), *Die natürlichen Pflanzenfamilien*, 3(2). Engelmann, Leipzig.
- Sargent, C. S. 1889. Portions of the journal of André Michaux, botanist, written during his travels in the United States and Canada, 1785 to 1796. *Proc. Amer. Philos. Soc.* 26(129): 1–145.
- Schulz, O. E. 1933. Kurze Notizen über neue Gattungen, Sektionen und Arten der Cruciferen. *Bot. Jahrb.* 66: 91–102.
- . 1936. Cruciferae. Pp. 227–658 in A. Engler & K. Prantl (editors), *Die natürlichen Pflanzenfamilien*, 2nd ed., 17B. Engelmann, Leipzig.
- Shishkin, B. K. & I. T. Vasilchenko (editors). 1948. *Flora Turkmenistan*, Vol. 3. Academy of Sciences, Ashkhabad, Turkmenistan.
- Swofford, D. L. 2000. PAUP*. *Phylogenetic Analysis Using Parsimony (*and other methods)*, Vers. 4. Sinauer, Sunderland, Massachusetts.
- Thompson, J. D., D. G. Higgins & T. J. Gibson. 1994. CLUSTAL W: Improving the sensitivity of progressive multiple sequence alignment through sequence weighting, positions-specific gap penalties and weight matrix choice. *Nucl. Acids Res.* 22: 4673–4680.
- Warwick, S. I., I. A. Al-Shehbaz & C. Sauder. 2006a. Phylogenetic position of *Arabidopsis arenicola* and generic limits of *Eutrema* and *Aphragmus* (Brassicaceae) based on sequences of nuclear ribosomal DNA. *Canad. J. Bot.* 84: 269–281.
- , A. Francis & I. A. Al-Shehbaz. 2006b. Brassicaceae: Species Checklist and database on CD-Rom. *Pl. Syst. Evol.* 259: 249–258.
- White, T. J., T. Burns, S. Lee & J. Taylor. 1990. Amplification and direct sequencing of fungal ribosomal RNA genes for phylogenetics. Pp. 315–322 in M. Innis, D. Gelfand, J. J. Sninsky & T. J. White (editors), *PCR Protocols: A Guide to Methods and Applications*. Academic Press, San Diego.
- Zunk, K., K. Mummenhoff, M. Koch & H. Hurka. 1996. Phylogenetic relationships of *Thlaspi* s.l. (subtribe Thlaspidinae, Lepidieae) and allied genera based on chloroplast DNA restriction-site variation. *Theor. Appl. Genet.* 92: 375–381.
- , ——— & H. Hurka. 1999. Phylogenetic relationships in tribe Lepidieae (Brassicaceae) based on chloroplast DNA restriction site variation. *Canad. J. Bot.* 77: 1504–1512.

A SYSTEMATIC REVISION OF *GAERTNERA* (RUBIACEAE, GAERTNEREAE)¹

Simon T. Malcomber² and Charlotte M. Taylor³

ABSTRACT

The Paleotropical genus *Gaertnera* Lam. (nom. cons.) comprises 69 species, plus one presumed natural hybrid, of shrubs and small trees found from West Africa to Sulawesi in southeastern Asia, with 13 of them newly described here. *Gaertnera* is characterized in the Rubiaceae by its tubular stipules of various forms, secondarily superior ovaries, and drupaceous fruits. Molecular phylogenetic analyses support *Gaertnera* as monophyletic and sister to the Neotropical genus *Pagamea* Aubl., but do not support infrageneric classification of *Gaertnera*. The morphology of *Gaertnera* is notably variable; molecular analyses indicate that most diversification is within regions, and that much of it is autapomorphic or homoplasious. *Gaertnera* species of Africa, Madagascar, the Mascarene Islands, and Sri Lanka are hermaphroditic and usually demonstrably distylous, while those of Southeast Asia for which information is available are dioecious, sometimes cryptically so, and apparently derived within the genus. All species recognized here are regional endemics, and accordingly regional keys are included here. In Africa, 12 species and two subspecies are recognized in this present work; *G. paniculata* Benth. is the most widespread of these; *G. aurea* Malcomber, *G. gabonensis* Malcomber, and *G. letouzeyi* Malcomber are newly described here; and the new combination *G. longivaginalis* (Schweinf. ex Hiern) E. M. A. Petit var. *bracteata* (E. M. A. Petit) Malcomber is made based on *G. bracteata* E. M. A. Petit. In Sri Lanka, six species plus the presumed natural hybrid *G. ×gardneri* Thwaites are recognized; all of these have been previously described; *G. vaginans* (DC.) Merr. is the most commonly collected. In Southeast Asia, 14 species are recognized here; *G. junghuhniana* Miq. is the most commonly collected and widespread; *G. alstonii* Malcomber, *G. aphanodioica* Malcomber, *G. belumutensis* Malcomber, *G. capitulata* Malcomber, and *G. kochummenii* Malcomber are newly described here. *Gaertnera* has its center of diversity in Madagascar and the Mascarene Islands, with 36 species and two subspecies recognized in this present work; *G. obovata* Baker of Madagascar is the most widespread and common; *G. ianthina* Malcomber, *G. lowryi* Malcomber, *G. monstrosa* Malcomber, *G. raphaelii* Malcomber, and *G. schatzii* Malcomber are newly described here; and the new combination *G. obovata* var. *sphaerocarpa* (Baker) Malcomber is made based on *G. sphaerocarpa* Baker. Here, *G. vaginans* is treated as a morphologically well-defined species of Sri Lanka, and the remaining plants included in this species by some previous authors are treated here in 10 additional species, four of them newly described. The following names are newly lectotypified: *G. crinita* Drake, *G. dinklagei* K. Schum., *G. fissistipula* (K. Schum. & K. Krause) E. M. A. Petit, *G. hispida* Aug. DC., *G. inflexa* Baill., *G. macrostipula* Baker, *G. oblanceolata* King & Gamble, *G. paniculata*, *G. phanerophlebia* Baker, *G. phyllostachya* Baker, *G. plagiocalyx* K. Schum., *G. sphaerocarpa* Baker, and *G. spicata* K. Schum. Original figures illustrate 24 species here, and an Index to Numbered Collections compiles the identifications of most of the ca. 3500 specimens studied.

Key words: *Aetheonoma*, Africa, Angola, Benin, Borneo, Brunei, Burkina Faso, Cambodia, Cameroon, Central African Republic, Côte d'Ivoire, Democratic Republic of the Congo, dioecy, floristics, *Fructesca*, Gabon, *Gaertnera*, Gaertnereae, Ghana, Guinea, heterodistyly, *Hymenocnemis*, Indonesia, IUCN Red List, Liberia, Madagascar, Mali, Mascarene Islands, Mauritius, Nigeria, *Pagamea*, phylogenetic analysis, *Pristidia*, Republic of the Congo, Réunion, Rubiaceae, Senegal, Sierra Leone, Southeast Asia, Sri Lanka, Sulawesi, Sumatra, *Sykesia*, taxonomy, Thailand, Togo, Vietnam, Zambia.

¹ S.T.M. gratefully acknowledges the following institutions, agencies, and societies for funding: National Science Foundation (NSF 9701008), Missouri Botanical Garden, American Society of Plant Taxonomists, Andrew Mellon Foundation, and Washington University in Saint Louis Division of Biology and Biomedical Sciences; the following herbaria for loaning material and/or providing access to collections: A, BM, BR, BRUN, CGE, E, FHO, G, G-DC, GH, K, KEP, L, MARS, MAU, MO, P, PDA, PRE, SAN, SAR, SING, TAN, TEF, University of Brunei Darussalam, W, WAG, and WU (acronyms according to Holmgren et al., 1990); L. Roger and J. Myers for artwork; and R. Gereau for preparation of Latin diagnoses. We acknowledge useful advice, comments, and assistance from J. Andriantiana, P. Ashton, A. P. Davis, C. Ewango, D. Florens, R. E. Gereau, D. Gower, D. Harder, C. Hemingway, A. Ibrahim, L. Jayratna, E. Kellogg, A. Larson, D. H. Lorence, J. Losos, P. P. Lowry III, M. Moïse, Y. Mongroo, M. Olson, T. Pailler, Peregrine Fund, P. Phillipson, A. Randrianasolo, P. H. Raven, S. G. Razafimandimbison, P. M. Richardson, Z. Rogers, Saw Leng Guan, G. Schatz, Solo, P. Stevens, J. Sugau, B. Sumithraarachichi, S. Teo Ping, J. Thompson, R. Thorstrom, G. Walters, and Wong Khoo Meng. S.T.M. acknowledges the following governmental agencies for granting or aid in obtaining field research permits: Association Nationale pour la Gestion des Aires Protégées (ANGAP); Ministère des Eaux et Forêts (MEF); Ministère de la Recherche Scientifique Centre National de Recherche Appliquée au Développement Rural (FOFIFA); National Botanical Garden, Peradeniya (Sri Lanka); Singapore Botanical Garden, National Parks Department, Singapore; Mauritius Wildlife Foundation, National Parks and Conservation Service, Mauritius; Brunei Darussalam Forestry Department, Universiti Brunei Darussalam; Economic Planning Unit (Malaysia), Forest Research Institute, Malaysia; Forest Research Centre, Sandakan; and Sarawak Herbarium.

² Program of Evolutionary and Population Biology, Washington University, St. Louis, Missouri, U.S.A.; and Missouri Botanical Garden, P.O. Box 299, St. Louis, Missouri 63166-0299, U.S.A. Current address: Department of Biological Sciences, California State University—Long Beach, 1250 Bellflower Blvd., Long Beach, California 90840-3702, U.S.A.

³ Missouri Botanical Garden, P.O. Box 299, St. Louis, Missouri 63166-0299, U.S.A. charlotte.taylor@mobot.org.
doi: 10.3417/2002161

Gaertnera Lam. (Rubiaceae) is a widespread and morphologically variable genus of small trees and shrubs found throughout the moist tropics of Africa, Madagascar, the Mascarene islands of Réunion and Mauritius, Sri Lanka, continental Southeast Asia, Borneo, and Sulawesi (Fig. 1). The genus is found from sea level to over 2000 m in evergreen forests, and grows in a variety of habitats from upland vegetation on clay and loam soils, to low-altitude swamps and littoral forests on laterite, white sand, or other substrates, to high-altitude moss forests in Sri Lanka. This is one of two genera of the tribe Gaertnereae, of the subfamily Rubioideae (Bremer & Manen, 2000; Robbrecht & Manen, 2006); the other is *Pagamea* Aubl. of South America. *Gaertnera* can be recognized by its woody habit; opposite or rarely ternate leaves; generally well-developed tubular stipules; distinctive ridges or wings that encircle the sides and bottom of the petiole and often extend upward onto the stipule sheath; cymose, few- to many-flowered, bracteate inflorescences borne in a terminal, pseudoaxillary, axillary, and/or supra-axillary position; calyx limb with a well-developed tube; salverform to funnellform, usually white to pink corollas with four or five valvate lobes; the ovary superior in flower; and also in the fleshy, purple-black drupaceous fruit (Fig. 2). The superior position of the ovary is unusual in the Rubiaceae and apparently secondarily derived (Igersheim et al., 1994). A few other Rubiaceae genera, mostly Neotropical, also have ovaries that are partially to fully superior at least in fruit (Robbrecht, 1988). *Gaertnera* is very similar to *Pagamea*, and these appear to be allopatric sister genera as discussed further below. *Gaertnera* is also similar in general aspect to species of *Chassalia* Comm. ex Poir. in some regions; however, *Chassalia* has smooth stipules and petiole bases and a fully inferior ovary in flower and fruit. *Gaertnera* is also notable for the variation in its breeding biology, with the species of Africa, Madagascar, the Mascarene Islands, and Sri Lanka for which the biology is known all distylous but the species of southeastern Asia apparently all dioecious, with this latter condition apparently derived (Malcomber, 2002). *Gaertnera* is additionally notable for its wide variation in morphological features but limited variation in the nucleotide sequences that are phylogenetically informative in many other plants (Malcomber, 2002), with similar characters evolved in parallel in geographically local radiations.

Gaertnera has not been monographed comprehensively since A. P. de Candolle's work (1845), but several regional treatments have been published. Baker (1877), Drake (1899), and Verdcourt (1983, 1989) treated the Mascarene species, which are by far

the most intensively studied. Drake (1899) also treated the Madagascar species. Petit (1959a, b, 1962) studied the African species, with a focus on those of the Congo region. Van Beusekom (1967) revised the Sri Lankan and Southeast Asian species, along with some taxa from Africa, Madagascar, and the Mascarene Islands that he considered related. Malcomber and Davis (2005) recently described several new species from Madagascar in a review of the *Gaertnera* species with 1- to few-flowered inflorescences found in that region.

We present a comprehensive revision of the species of *Gaertnera* here, based primarily on study of herbarium specimens, molecular analyses, and field-work by S.T.M. The species circumscriptions are based on Malcomber (2000) and should be credited solely to S.T.M. This present work will be supplemented by some additional materials presented online (<<http://www.tropicos.org/Project/Rubiaceae>>).

As with other tropical Rubiaceae, many species of *Gaertnera* are geographically restricted and/or poorly known. In fact, the Mascarene species *G. calycina* Bojer and *G. crassiflora* Bojer are considered extinct, and other *Gaertnera* species must be considered on the verge of extinction given the current knowledge of their geographic range. However, the Mascarene species *G. longifolia* Bojer was also considered extinct at one time (Walter & Gillett, 1998) but has been rediscovered in an area dominated by introduced species (Anonymous, 1997). Similarly, before this present study, *G. fractiflexa* Beusekom, *G. globigera* Beusekom, and *G. schizocalyx* Bremek., all from Malaysia, as well as *G. microphylla* Capuron ex Malcomber & A. P. Davis from Madagascar had not been collected for 35 to 100 years, but all were located again by S.T.M. in 1997–1998. With the current rate of deforestation in the tropics, additional research on the population size and ecological requirements of many species are desperately required if there is to be any long-term conservation of many of these species.

METHODS

DESCRIPTIVE DATA

This revision of *Gaertnera* is based on the study of more than 3500 herbarium specimens from throughout its range, and on field studies conducted by S.T.M. over 12 months in Brunei, Madagascar, Malaysia, Mauritius, Singapore, and Sri Lanka, during which 230 collections were made. Specimens were studied from the collections cited in the acknowledgments. Flower and fruit measurements are based on collections preserved in alcohol or rehydrated herbarium

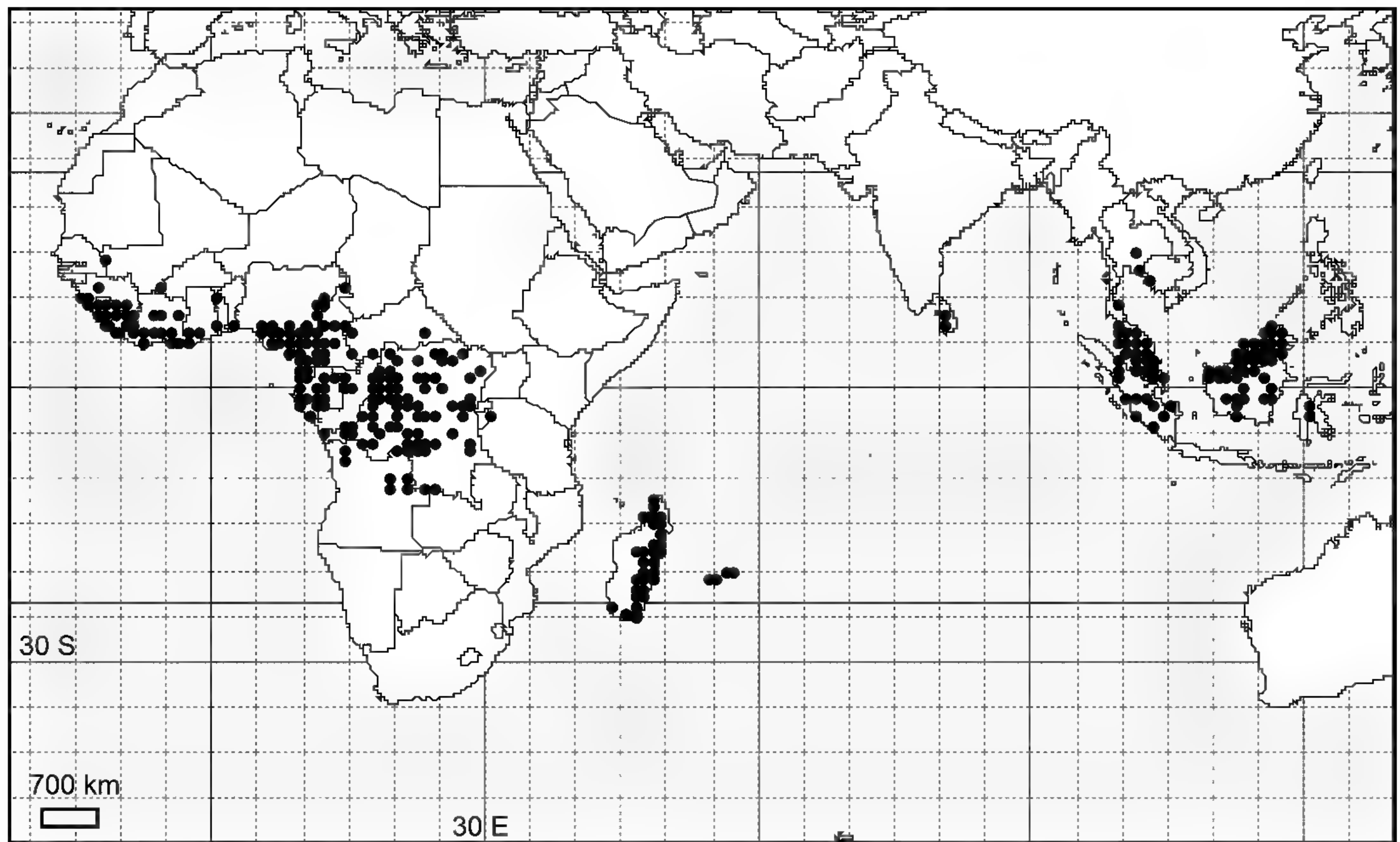

Figure 1. Geographic range of *Gaertnera*. Points represent individual herbarium specimens.

specimens. All other measurements (e.g., leaf length, leaf width, stipule length, cyme length and width) were taken from dried specimens. The species descriptions were initially generated using DELTA software (Dallwitz et al., 1999) and then edited.

In the treatment below, the morphological characters of the genus are summarized in the genus description. In the individual species descriptions for several characters, only the uncommon conditions are described, e.g., the fenestrate corolla of one species and the pendulous inflorescences of a few species. Only selected specimens are provided as broad geographic vouchers except in a few cases in which the species are poorly known or newly described here; a complete list of the numbered collections and their identifications is included as Appendix 1. All collectors are identified there by initials of first names where possible; only collectors of unnumbered specimens are thus identified in the specimens cited in the text. However, some collectors only use one name (e.g., Dorr, 1997), while a few first names have not been traced. For some relatively small areas (e.g., Réunion, Mauritius), internal political units are not separated.

An index of all taxa treated in the current revision is provided in Appendix 2, with accepted names in *Gaertnera* presented in boldface.

In a few cases, holotype specimens deposited at P were not located. The searching done for these specimens at that institution was extensive but not

exhaustive, and did locate some materials. Thus, we are reluctant to conclude that the remaining missing specimens are lost and therefore have not yet lectotypified several names pending further searching, although lectotypification may ultimately be necessary.

SPECIES CIRCUMSCRIPTION

What constitutes a species is controversial, and at least 22 different species concepts have now been published (Mishler, 1999). However, most concepts equate species with population lineages and only differ in the phenomena emphasized to diagnose inclusion within the category (De Queiroz, 1998). The diagnosable morphological units classified here as species are hypotheses recognized by non-overlapping character distributions. Units that are diagnosable at the limits of their morphological range but not diagnosable otherwise and overlapping geographically are classified here as varieties. The units recognized in this revision satisfy the criteria imposed by the general lineage concept of species, and therefore represent segments of population-level evolutionary lineages (De Queiroz, 1998, 1999). Preliminary phylogenetic analyses of separate and combined nuclear DNA (nDNA) data sets for *Gaertnera* species using the nDNA markers ITS, *PepC*-Large (*PepC*-L), *PepC*-Small (*PepC*-S), and *Tpi* found that multiple accessions of the same species all formed a single

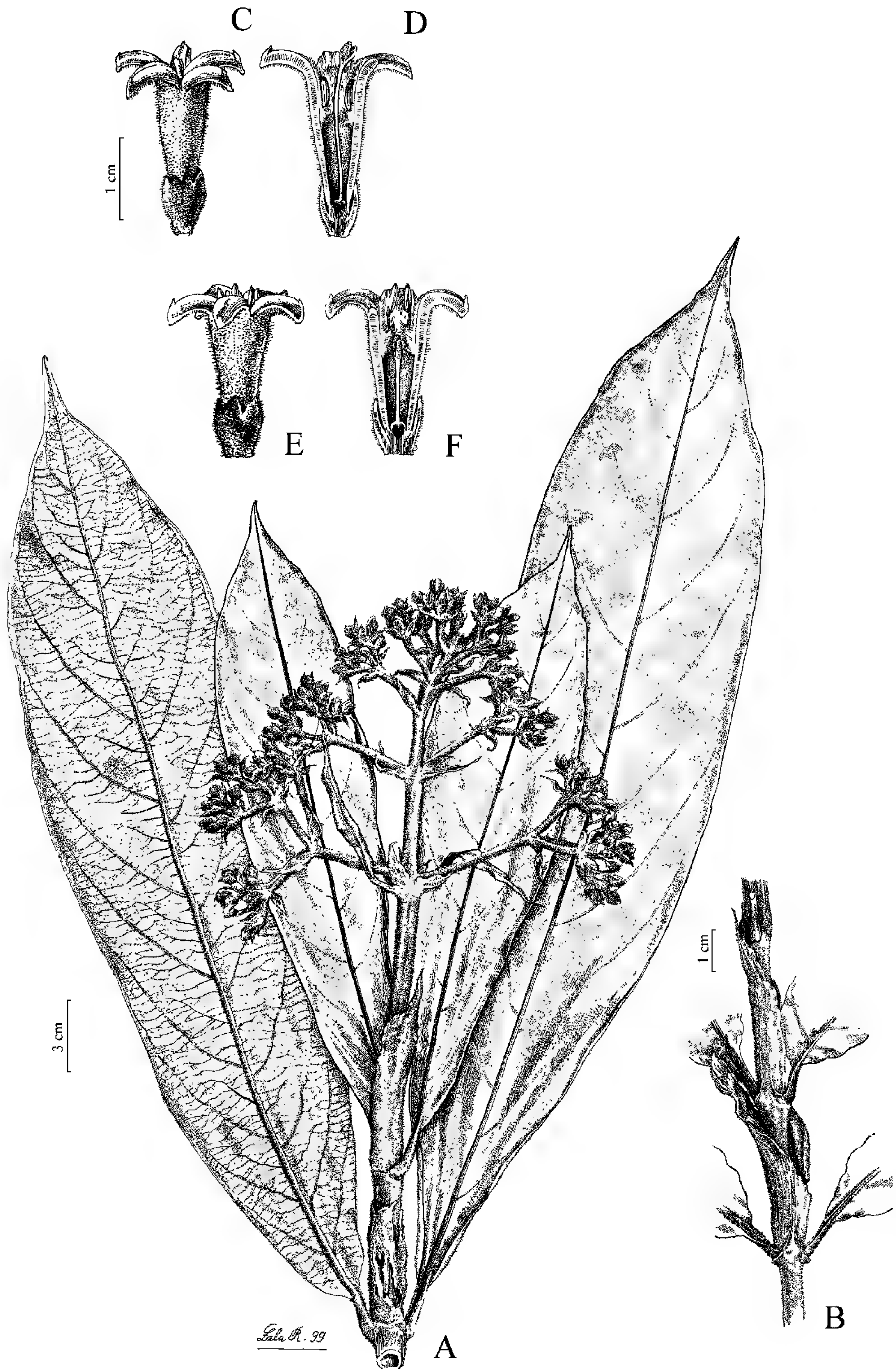

Figure 2. *Gaertnera schatzii* Malcomber. —A. Flowering branch. —B. Portion of stem with leaf bases and stipules. —C. Long-styled flower. —D. Long-styled flower in cross section. —E. Short-styled flower. —F. Short-styled flower in cross section. C–F to same 1-cm scale. A, B based on *Malcomber 2829*; C–F based on *Moise 9*.

Table 1. List of sequences included in the molecular analyses. Herbarium voucher information is included within the GenBank accession number.

Taxon	ITS	<i>PepC</i> -Large	<i>PepC</i> -Small
<i>Gaertnera aphanodioica</i> Malcomber	AF333817	AY046371	AF333876
<i>G. arenaria</i> Baker	AY185543	AY185544	AY185545
<i>G. belumutensis</i> Malcomber	AF333818	AF333849	AF333877
<i>G. brevipedicellata</i> Malcomber & A. P. Davis	AF333819	AY046374	AY046344
<i>G. capitulata</i> Malcomber	AY185546	AY185547	AY185548
<i>G. cooperi</i> Hutch. & M. B. Moss	AF333820	AF333851	AF333879
<i>G. cuneifolia</i> Bojer	AF333821	AY046376	AY046346
<i>G. drakeana</i> Aug. DC.	AF333822	AF333853	AY046348
<i>G. edentata</i> Bojer	AF333823	AF333854	AF333882
<i>G. fractiflexa</i> Beusekom	AF333824	AF333855	AY046357
<i>G. globigera</i> Beusekom	AF333825	AF333856	AY046333
<i>G. hispida</i> Aug. DC.	AF333826	AF333857	AF333885
<i>G. inflexa</i> Baill.	AF333827	AF333858	AY046335
<i>G. junghuhniana</i> Miq.	AY046326	AY046377	AY046365
<i>G. longivaginalis</i> (Schweinf. ex Hiern) E. M. A. Petit	AY185549	AY185550	AY185551
<i>G. longifolia</i> Bojer	AF333829	AF333860	AY046337
<i>G. lowryi</i> Malcomber	AF333830	AY046379	AY046341
<i>G. macrostipula</i> Baker	AF333831	AF333862	AY046343
<i>G. madagascariensis</i> (Hook. f.) Malcomber & A. P. Davis	AF333832	AF333863	AF333891
<i>G. oblanceolata</i> King & Gamble	AF333833	AF333864	AF333892
<i>G. paniculata</i> Benth.	AY046329	AF333865	AF333893
<i>G. pauciflora</i> Malcomber & A. P. Davis	AF333835	AF333866	AF333894
<i>G. psychotrioides</i> (DC.) Baker	AF333835	AF333867	AY046362
<i>G. ramosa</i> Ridl.	AF333816	AF33384	AY046338
<i>G. rosea</i> Thwaites ex Benth.	AF333837	—	AF333896
<i>G. schatzii</i> Malcomber	AF333838	AF333868	AF333897
<i>G. schizocalyx</i> Bremek.	AF333839	AF333869	AY046355
<i>G. ternifolia</i> Thwaites	AY046331	AF333870	AY046361
<i>G. vaginans</i> (DC.) Merr.	AF333841	—	AY046350
<i>G. viminea</i> Hook. f. ex C. B. Clarke	AF333842	AF333871	AY046354
<i>G. walkeri</i> (Arn.) Blume	AF333843	AF333872	AY046356
<i>Morinda citrifolia</i> L.	AF333844	AF333873	AF333903
<i>M. royoc</i> L.	AF333845	AF333874	AY046370
<i>Pagamea guianensis</i> Aubl.	AF333846	—	AF333905

cluster, and thus represent phylogenetic species (Malcomber, 2002, unpublished data).

MOLECULAR PHYLOGENETICS

ITS, *PepC*-L, and *PepC*-S sequences for 29 *Gaertnera* species, *Pagamea guianensis* Aubl. as a representative of the sister genus, and the outgroups *Morinda citrifolia* L. and *M. royoc* L. (i.e., the sequences previously analyzed by Malcomber & Davis, 2005) were supplemented with ITS, *PepC*-L, and *PepC*-S sequences for *G. arenaria* Baker and *G. capitulata* Malcomber (Table 1). The 31 *Gaertnera* species included in this analysis sample the entire geographic range of the genus (Gabon, Democratic Republic of the Congo, Madagascar, Mauritius, Sri Lanka, Malaysia, and Brunei) and include nine of the 12 species recognized here within the *G. vaginans* complex (discussed below).

Total genomic DNA was extracted from silica-dried leaves using the CTAB miniprep protocol of Doyle and Doyle (1987). Double-stranded polymerase chain reaction (PCR) products of the ITS region were amplified using the primers ITSLEU1 and ITS4, and the two copies of the fourth intron of *PepC* were amplified using the primers PEPCX4F and PEPCX5R in 50 µl PCR reactions as described in Malcomber (2002). The ITS PCR reactions produced a single product of approximately 650 bp, whereas the *PepC* PCR reactions amplified two distinct products of approximately 450 bp and 900 bp. PCR products were gel purified using Qiaquick columns (Qiagen Inc., Valencia, California, U.S.A.) and sub-cloned using pGEM-T easy vector systems (Promega Corp., Madison, Wisconsin, U.S.A.). Plasmid DNA was cleaned using an alkaline lysis/PEG precipitation protocol (Sambrook et al., 1989) prior to sequencing. ITS clones were sequenced using plasmid primers T7

and SP6 and internal primers ITS2 (White et al., 1990) and ITS3B (Baum et al., 1994). To check for intra-individual variation among ITS paralogs, two to four clones were sequenced and dimethyl sulfoxide was used in both the PCR and sequencing reactions, following the recommendations of Buckler et al. (1997). *PepC* clones were sequenced in both directions using plasmid primers T7 and SP6 for the 450 bp (*PepC-S*) product and primers T7, PEPCINTF, PEPCINTR, and SP6 for the 900 bp (*PepC-L*) product as described in Malcomber (2002). Dideoxy sequencing was conducted using the BigDye dye terminator cycle sequencing protocol (from Applied Biosystems, Foster City, California, U.S.A.), and sequencing reactions were analyzed on an ABI3100 (Applied Biosystems) automated DNA sequencer.

Preliminary alignment of the ITS, *PepC-L*, and *PepC-S* sequences was performed using Clustal W (Thompson et al., 1994), before being manually edited using MacClade 4.0 (Maddison & Maddison, 2003). Sequences were analyzed using Bayesian phylogenetic methods as implemented in MrBayes 3.2 (Huelsenbeck & Ronquist, 2001) using the general time reversible (GTR) model of evolution and Gamma distributed rates (GTR + G), as estimated by Modeltest 3.06 (Posada & Crandall, 1998). Each Markov chain was started from a random tree and run twice for 5,000,000 cycles each, sampling every 100th cycle from the chain. Four chains were run simultaneously with the initial 2000 cycles discarded as burn-in. To verify that stationarity had been reached, the fluctuating value of the likelihood was monitored graphically. Default settings for the priors were used on the rate matrix, branch lengths, gamma shape parameter, and proportion of invariable sites. Posterior probabilities were used to evaluate the support of specific nodes.

TAXONOMIC HISTORY AND GENERIC RELATIONSHIPS

Gaertnera was described by Lamarck (1792) as a genus of Rubiaceae based on a Commerson collection labeled as coming from Île de France, today called Mauritius. Verdcourt (1989) noted that the Commerson collection was undoubtedly made on Réunion (then called Bourbon) instead. *Gaertnera* was named in honor of German botanist Joseph Gaertner (1732–1791), who researched the seed and fruit structures of angiosperms. Lamarck subsequently described one species, *G. vaginata* Lam. The places of publication, dates, and authorship of these names have been widely (and variously) cited incorrectly. Several of Lamarck's contemporary authors also described genera named for Gaertner, thus complicating the

nomenclature of this genus. The name *Gaertnera* is formally conserved in the usage detailed here; the list of excluded names is relatively long here because several of these *Gaertnera* species were described in other, homonymic genera. As an earlier solution to the problem of the duplicated genus names, Kuntze (1891) replaced *Gaertnera* as the name used for the plants treated here with the name *Sykesia* Arn., as discussed below. Petit (1959a) has summarized much of the nomenclatural history of *Gaertnera*.

Although Gaertner (1806) remarked that this genus clearly belonged in the Rubiaceae despite its superior ovary, Jussieu (1807) contemporaneously first concluded that *Gaertnera* did not belong in the Rubiaceae. He noted that although the opposite leaves, fused stipules, flowers arranged in a corymb, and opposite branching pattern all suggested affinities between *Gaertnera* and members of the Rubiaceae, the superior ovary of the fruit instead suggested affinities with the Apocynaceae. He concluded that *Gaertnera* was better included in a new family transitional between the Apocynaceae and Rubiaceae. Brown (1814) implemented this, describing the family "Loganeae" (i.e., Loganiaceae) to include *Logania* R. Br., *Geniostoma* J. R. Forst. & G. Forst., *Usteria* Willd., *Gaertnera*, *Pagamea*, and provisionally *Fagraea* Thunb., although he later (1818) regarded this family as not completely natural. *Gaertnera* was retained in the Loganiaceae by de Candolle (1845) and Bentham and Hooker (1876). Baillon (1879) then returned *Gaertnera* to the Rubiaceae, noting that *Pagamea* and *Gaertnera* did not differ significantly from *Psychotria* L. and *Chassalia* because *Gaertnera*'s ovary was not completely free, as in other Loganiaceae, but fused to the calyx at the base. Solereder (1890) agreed that *Gaertnera* belonged in the Rubiaceae based on the presence of raphides and the absence of intraxylary phloem, and concluded that it was related to *Psychotria* and *Chassalia*. *Gaertnera* was subsequently usually included within the Rubiaceae (Schumann, 1891; Klett, 1924; Bremekamp, 1954, 1966; Verdcourt, 1958; Robbrecht, 1988) but was still sometimes included in Loganiaceae (De Cordonoy, 1893; Ridley, 1908, 1915, 1934; Fischer, 1927, 1928; Hutchinson & Dalziel, 1931). Recent molecular analyses have all confirmed the placement of *Gaertnera* and *Pagamea* in the Rubiaceae and agreed on a close relationship between these two genera, *Psychotria*, and *Morinda* L. (Bremer, 1996; Andersson & Rova, 1999; Nepokroeff et al., 1999).

A close relationship between *Gaertnera* and the South American genus *Pagamea* has been hypothesized since the early 19th century, based on their shared sheathing stipules and secondarily derived superior ovaries, and more recently based also on

their xylem with parenchyma bands and compound pollen apertures with crescent-shaped “costae” (Igershiem et al., 1994; Jansen et al., 1996a, b, 1997). Molecular phylogenetic analyses of chloroplast DNA (cpDNA) (Andersson & Rova, 1999) found *Gaertnera* and *Pagamea* to form a well-supported clade related to the Morindeae and Psychotrieae, and subsequent authors have treated this clade as a tribe (Bremer & Manen, 2000; Robbrecht & Manen, 2006).

Although molecular phylogenetic analyses of multiple nDNA (Malcomber, 2002) and cpDNA (Vicentini, 2007) regions suggest that *Gaertnera* and *Pagamea* are both monophyletic, few morphological synapomorphies distinguish the genera. The only consistent one is the presence of indumentum on the inside (i.e., adaxial face) of the corolla lobes in *Pagamea* (Taylor et al., 2004) versus glabrous in *Gaertnera*. Another morphological difference may be the development of the distinctive ridge or wing surrounding the base of the petiole in *Gaertnera*, which is apparently absent in *Pagamea*; however, this structure is reduced and difficult to detect in some species of *Gaertnera*. Some characters that have been used to separate the two genera cannot be interpreted as synapomorphies. *Gaertnera* cannot be differentiated from *Pagamea* based on the position of the inflorescence: in *Pagamea* the inflorescence is axillary, while in *Gaertnera* it is usually terminal but may be supra-axillary (e.g., *G. diversifolia* Ridl.) or axillary (e.g., *G. ob lanceolata* King & Gamble). Schumann (1891) reported that these genera also differ in the ruminant endosperm of *Pagamea* (Piesschaert, 2001) versus entire in *Gaertnera*, but a few species of *Gaertnera* (e.g., *G. cooperi* Hutch. & M. B. Moss, *G. aurea* Malcomber) also have ruminant endosperm. Wood anatomy and pollen morphology may provide additional synapomorphies to support the monophyly of the two genera: Jansen et al. (1996b) demonstrated that eight *Gaertnera* species from Africa and the Mascarene Islands differ from four *Pagamea* species in wood anatomy and in pollen morphology. In particular, they documented wood differences in vessel outline, diameter, and density, and number of cells in the parenchyma bands and the distance between the bands, and that *Pagamea* pollen is smaller than *Gaertnera* pollen, has a more rounded outline in polar view, and has a less-developed margo. However, these conclusions are based on a partial sampling of both genera and remain to be confirmed globally.

GENERIC CIRCUMSCRIPTION AND INFRAGENERIC CLASSIFICATION

Arnott (1836) accepted the placement of *Gaertnera* in the Loganiaceae and established the tribe Gaert-

nereae for this and *Sykesia*, which was separated from *Gaertnera* based on the presence of hairs in the corolla throat and comprised three species from Sri Lanka. Endlicher (1838) subsequently included *Sykesia* in *Gaertnera* but did not publish nomenclatural combinations for the species.

De Candolle (1845) recognized two genera again, with *Gaertnera* comprising only Mascarene species. He also recognized two sections of *Gaertnera*, section *Aetheonoma* A. DC. with the single species *G. calycina*, and section “*Eugaertnera*” (i.e., section *Gaertnera* according to current rules of nomenclature) with the remaining 13 species. Section *Aetheonoma* was distinguished by its bracteoles paired and borne well below the base of the calyx, its broad calyx, and its anthers arranged with three alternate to the petals and two opposite them; this last condition has not been found by others (S.T.M., pers. obs.; Verdcourt, 1983). Section *Gaertnera* was characterized by having bracts borne at the base of the calyx and the anthers all alternate to the corolla lobes, with no calyx condition specified. The name “*Aethonoma*” apparently was taken from an unpublished manuscript name, “*Gaertnera aetheonoma* Steud.,” cited in synonymy with *G. calycina* by de Candolle. No valid publication of that name, as a genus or species, has been found.

As de Candolle also noted (1845: 32), Meisner had previously published the name *Fructesca mauritiana* DC. ex Meisn. for a plant that was probably a *Gaertnera*, but no description accompanied the name, thus it was not validly published and he reported that its specimen was so incomplete that its identity could not be confirmed further. There was, however, a limited description presented by Meisner for the new genus *Fructesca* DC. ex Meisn. with only one species listed in that genus, thus it can be considered validly published under our current rules. The only distinguishing characters given were a 5-lobed calyx with the lobes linear, a stipule sheath entire or usually with two incisions, and a contracted inflorescence. The calyx and inflorescence characters suggest this name might apply to *G. cuneifolia* Bojer, but the stipules of that are calyptrate and deciduous; thus, the identity of this name is still unknown.

De Candolle’s (1845) circumscription of *Gaertnera* was formally expanded first by Blume (1850), who synonymized *Sykesia* and provided names for its species in *Gaertnera*. Subsequently, Bentham (1857) also synonymized *Sykesia* and recognized three sections of *Gaertnera*: sections *Aetheonoma*, “*Eugaertnera* DC.,” and *Sykesia* (Arn.) Benth. These sections were separated by calyx size and presence versus absence of villous hairs inside the corolla tube. Bentham and Hooker (1876) later reduced these to

two sections separated only by corolla size: sections “*Eugaertnera*” and *Sykesia*; the classification of section *Aetheonoma* was not explained.

Schumann (1891) was the last author to recognize an infrageneric classification of *Gaertnera*, comprising sections *Aetheonoma* and “*Eugaertnera*” (i.e., section *Gaertnera*). Within section *Gaertnera* he also described two series: series *Densiflorae* K. Schum. comprised the Mascarene species with sessile flowers in congested to capitate inflorescences, and series *Laxiflorae* K. Schum. comprised species of various regions with sessile to pedicellate flowers in branched cymes. Schumann listed *G. vaginata*, the type of the genus, as a member of series *Laxiflorae*; thus, under current rules of nomenclature this is correctly called series *Gaertnera*.

The genus “*Andersonia* Willd.” was mentioned (Roemer & Schultes, 1819) only in a note to the treatment of the Neotropical genus *Exostema* (Pers.) Bonpl. This note discussed a manuscript description of one species, “*A. vaginata* Willd.,” written by Willdenow based on a plant collected by Dupetit-Thouars in Madagascar and did not mention a superior ovary. Roemer and Schultes noted that this manuscript description had been assigned a position between *Exostema* and *Solena* Willd. (hom. illeg., non *Solena* Lour.; *Solena* Willd. is equivalent to *Posoqueria* Aubl.) but that its identity was not clear; thus, those authors were not treating it as either a synonym or a recognized genus and thus were not accepting it. They also noted that this genus name had previously been used, as *Andersonia* R. Br. (Epacridaceae). Thus, Willdenow’s name cannot be considered validly published and must be regarded as a nomen nudum at best.

The monotypic Madagascar genus *Hymenocnemis* Hook. f. was described based on its combination of bilocular ovaries, calyptrate stipules, 4-merous flowers, usually 1-flowered inflorescences, unequal calyx lobes, and anthers with prominent appendages. Baker (1877) also recognized *Hymenocnemis* and suggested it was closely related to *Gaertnera*. Schumann (1891) also recognized both genera and placed them both in the tribe Psychotrieae, but did not suggest any particularly close relationships for them. The genera were also separated by Drake (1899). Recently, Malcomber and Davis (2005) reevaluated their relationship with molecular data and found *H. madagascariensis* Hook. f. deeply nested within *Gaertnera* and formally synonymized it.

Kuntze (1891) noted in his review of flowering plant nomenclature that the name *Gaertnera* had been published for other plants before the Rubiaceae genus was described and used the next available Rubiaceae name for the genus *Sykesia*. Kuntze provided

combinations for all of the then-recognized *Gaertnera* species; some of these have been noted by previous authors (van Beusekom, 1967), but others have been overlooked.

The genus *Tsiangia* But, H. H. Hsue & P. T. Li has been associated with *Gaertnera* in some lists because its sole species was originally described in this genus, *G. hongkongensis* Seem. However, Bentham (1857) noted that this name was based on a teratologically malformed specimen, and Bridson (2000) agreed and formally synonymized this name with *Ixora chinensis* Lam.

No infrageneric classifications have been accepted by recent authors and none are presented here, because despite *Gaertnera*’s broad geographic range, morphological variability, and the partial correlation of some characters with biogeographic distribution, no species groups can be clearly delimited within *Gaertnera* by either morphological or molecular characters (Fig. 3).

MORPHOLOGY

Plants of *Gaertnera* are terrestrial, usually shrubs or small trees up to 15 m tall, although a few species (e.g., *G. ternifolia* Thwaites, *G. microphylla*) are subshrubs growing to only ca. 1 m tall or the plants may be rarely clambering (e.g., *G. brevipedicellata* Malcomber & A. P. Davis, *G. cardiocarpa* Boivin ex Baill., *G. darcyana* Malcomber & A. P. Davis). Most species are found in forest understory, although several species, notably *G. obovata* Baker and some members of the *G. vaginans* complex (*G. aphanodioica* Malcomber, *G. arenaria*, *G. junghuhniana* Miq., *G. paniculata* Benth., and *G. vaginans* (DC.) Merr.) are often found in open disturbed sites such as forest edges. The plants are generally well branched, although few species (*G. obesa* Hook. f. ex C. B. Clarke, *G. monstrosa* Malcomber) are typically monocaulous. A few species produce differentiated reproductive branches with flexuous to pendulous stems and reduced leaves, often from a supra-axillary position (*G. diversifolia*, *G. inflexa* Baill.). The developmental origin of these branches is not clear from observation of whole plants and has not been investigated here. These reproductive branches vary widely in length and are not found on all plants of a species; they appear to have evolved in parallel within *Gaertnera* in Madagascar and in Southeast Asia. The bark is smooth in all species except *G. eketensis* Wernham, which has distinctive striated or fissured bark.

Plants of *Gaertnera* vary from glabrous throughout the vegetative structures and sometimes also the reproductive structures, to densely pubescent with

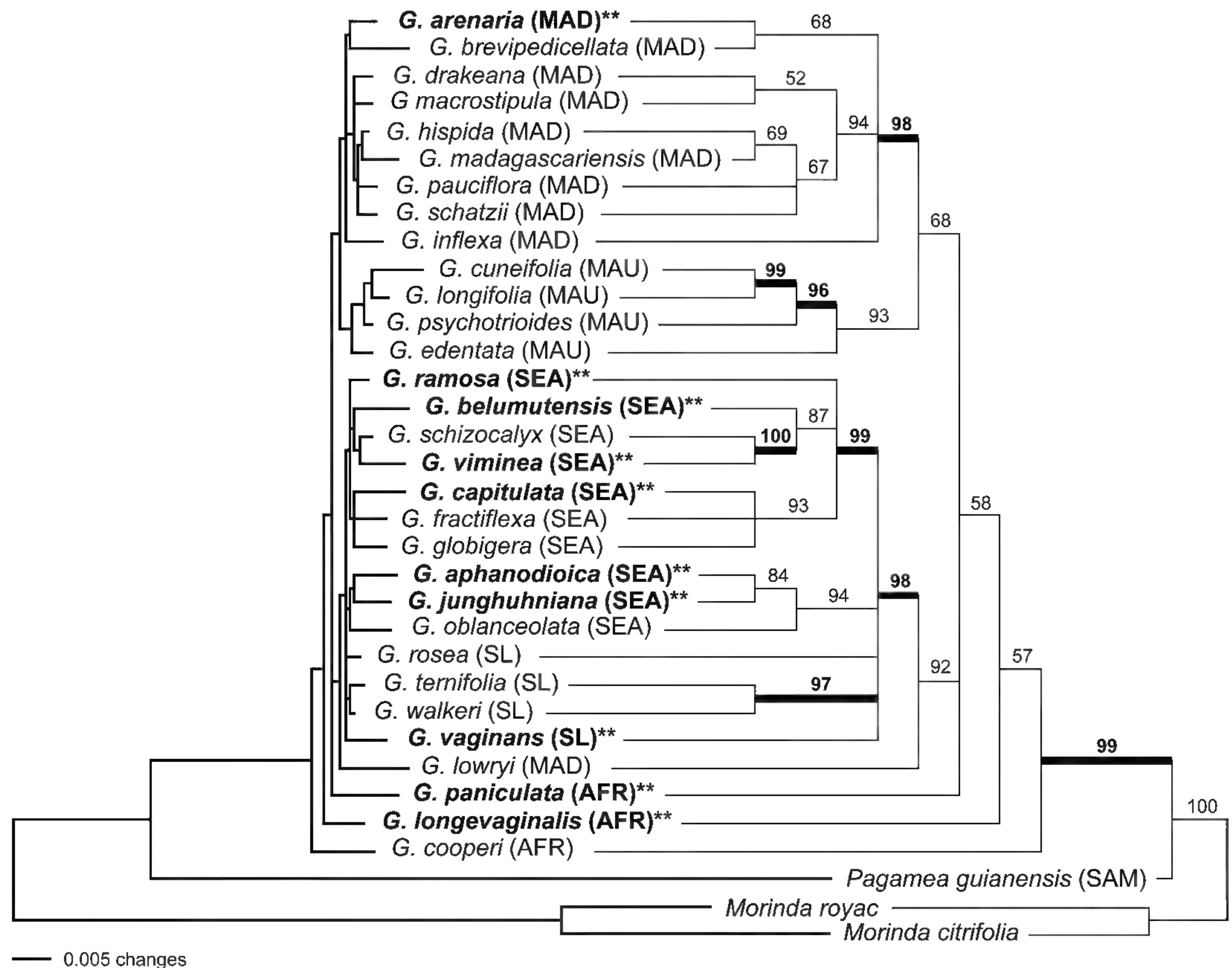

Figure 3. Bayesian consensus phylogram (left-hand side) and Bayesian consensus cladogram (right-hand side) for 31 species of *Gaertnera*, *Pagamea guianensis*, and two outgroup taxa (*Morinda citrifolia*, *M. royoc*), based on combined sequence data for ITS, *PepC-L*, and *PepC-S* using the general time reversible model and gamma-distributed rates (GTR + G); taxa analyzed and sequence information are listed in Table 1. Numbers above branches in the Bayesian consensus cladogram represent clade credibility percentages. Branches shown in bold there are considered well supported (≥ 0.95 clade credibility). Species names shown in bold with double asterisks were included in van Beusekom's (1968) broad circumscription of *G. vaginans*; see discussion in text. AFR, Africa; MAD, Madagascar; MAU, Mauritius; SEA, Southeast Asia; SL, Sri Lanka.

various types of indumentum including shortly puberulent, tomentose, pilosulose, scabrous, hirtellous, hirsute, and velutinous (sensu Lawrence, 1951). The pubescence of the petioles is not described separately here but is generally similar to that of the underside of the leaf midrib. The stems of many plants are pubescent when young but lose their vesture to become glabrescent with age. The presence, density, and type of pubescence may vary within a species (e.g., *G. trachystyla* (Hiern) E. M. A. Petit, *G. phanerophlebia* Baker), but it sometimes appears to distinguish species (e.g., *G. bieleri* (De Wild.) E. M. A. Petit vs. *G. leucothyrsa* (K. Krause) E. M. A. Petit). The pubescence colors described here are those of dried specimens; in life, the trichomes are clear or whitened. This dried color is often consistent and distinctive for individual species.

No chemical studies of *Gaertnera* have been seen, but some variation in secondary compounds is suggested by the colors and patterns found on dried specimens. In addition to the dried trichomes, in many species the entire specimen of *Gaertnera* has a characteristic brown or chestnut brown color, similar to that found in *Psychotria* subg. *Psychotria* (Hamilton, 1989). A few *Gaertnera* species have a characteristic orange drying color (*G. belumutensis* Malcomber, *G. kochummenii* Malcomber, *G. schatzii* Malcomber) that presumably is not an artifact of the specimen preparation; similar coloration is seen in individual species of other genera (e.g., *P. stenostachya* Standl.). These distinctive dried colors have been assumed to be due to characteristic secondary compounds, but no actual chemical cause is known. When the drying color is not detailed here, it is green,

dull green, brownish green, or gray-green. Many specimens of *Gaertnera* also show small inclusions, visible under $7.5\times$ magnification, in the epidermal cells of the leaves. These inclusions have a dark drying color that contrasts with the rest of the cell (or other cells); the character of these inclusions is unknown. As with other members of Rubioideae, *Gaertnera* has raphides, composed of calcium oxalate crystals, as inclusions in its tissues (Robbrecht, 1988). The wood anatomy was studied in detail by Jansen et al. (1996b).

The stems are variously terete to quadrangular or flattened, with the angled or flattened shape of the young internodes usually filling out to become cylindrical with age. Several species have distinctive longitudinal ridges or ribs that extend from the middle of the interpetiolar base of the stipule down the middle of the internode, called "interpetiolar ridges" here. This feature appears to be generally consistent within a species, although it seems to vary within a few species (e.g., *Gaertnera paniculata*). Van Beusekom (1967) noted that the data for several collections of *G. obesa* mention that the plants harbored ants, presumably in the stems. An association with ants was also noted in some populations of *G. aphanodioica* in Brunei and a population of *G. oblanceolata* in Sarawak, Malaysia, during field studies by S.T.M., with the ants accessing the stem via holes left by the removal of old branches.

The leaves are decussate and opposite or occasionally ternate (*Gaertnera ternifolia*). The arrangement seems to be consistent within a species, and the variation in this feature found in some Sri Lankan plants is considered indicative here of their hybrid origin (*G. \times gardneri* Thwaites). The leaves are subsessile to usually petiolate with a well-developed blade that varies from small and narrowly elliptic (*G. ternifolia*, $0.5\text{--}2.5 \times 0.1\text{--}0.3$ cm) to relatively large and obovate or broadly elliptic (to 55×19 cm, *G. monstrosa*, *G. obesa*). In a few species, the leaves aid in distinguishing species, but in general, as noted by van Beusekom (1967), the leaves are so similar between species that they do not present many taxonomically informative characters.

The leaf margins are entire and generally flat but may be markedly crisped (e.g., *Gaertnera ianthina* Malcomber), thinly revolute (e.g., *G. cuneifolia*), or thickened (e.g., *G. diversifolia*). The blades range from papery in texture to stiffly leathery. This character distinguishes some species; the texture described here is that of the dried leaves, which is generally correlated with the living texture. The secondary veins are generally eucamptodromous and broadly arching. Most species bear acarodomatia on the undersides of the leaves, in the axils of the secondary

veins with the costa (Robbrecht, 1988). These structures comprise small to well-developed tufts of hirtellous pubescence on the surface of the blade and sometimes also the surrounding veins ("tuft-domatia" of Robbrecht, 1988), usually situated within a shallow concavity, and additionally may be enclosed by an outgrowth of tissue of the veins ("hairy pocket-domatia") or deeply concave and surrounded by an outgrowth of tissue of the leaves ("ciliate pit-domatia" to "crypt-domatia"). *Gaertnera* species frequently have several of these forms (e.g., *G. phyllostachya* Baker); in the descriptions below, only quite uncommon domatia types are described. The presence of domatia on an individual plant (or individual specimen, at least) appears to be variable in many *Gaertnera* species.

The form of stipules of *Gaertnera* is rather unusual within the Rubiaceae and distinctive for the genus and often for a species. In all species of *Gaertnera*, the stipules are fused around the stem into a well-developed tube or sheath that is usually subtruncate except with two or four lobes. Generally, similar stipules are found in the closely related genus *Pagamea*, but as noted above, *Gaertnera* differs from *Pagamea* in the wing or rib that extends down from the stipule to encircle the base of the petiole (e.g., Figs. 4–6); the stem distal to the petiole is smooth in *Pagamea*. These ridges vary from only a little elevated (e.g., *G. sralensis* (Pierre ex Pit.) Kerr) to well-developed ridges or thin to broad wings. In a few *Gaertnera* species with relatively small stature (e.g., *G. ternifolia*, *G. walkeri* (Arn.) Blume), the stipules are persistent and relatively small and similar to those of a number of other Rubiaceae genera. However, in most *Gaertnera* species, the stipules have relatively well-developed tubular sheaths (5–75 mm long) that are caducous or quickly deciduous through fragmentation, breaking apart irregularly or occasionally leaving a persistent truncate base. Two different stipule forms are found in *Gaertnera*: tubular stipules are cylindrical with an open top in bud, so the leaves push through without damaging the sheath, which widens as the stem increases in diameter; calyptrate stipules are fully fused to form a cap covering the bud, so the expanding young stem and leaves split this structure as they push through it. Vegetative stem apices are needed to confirm the calyptrate stipule form. Both tubular and calyptrate stipules may be caducous or deciduous through fragmentation, with little evident correlation between persistence and form; only tubular stipules have been seen to regularly persist on most of the stem nodes.

In most species, the stipule sheath is cylindrical or tubular, but a few species have an inflated stipule sheath or tube that often widens toward the top to form

a funnellform or vase-like structure (*Gaertnera obesa*, *G. macrostipula* Baker). The dried texture of the stipule tube varies from membranous to leathery and is considered characteristic of individual species here. The stipule tube or sheath remains entire, or often splits along one side to form a spathaceous structure, or sometimes splits along two sides to form two segments; the pattern of splitting is described below in some detail, although as more collections of *Gaertnera* become available, this character appears to be less consistent within some species than previously thought. The top of the stipule sheath may be truncate, asymmetrically 1-lobed, or bilobed and may have variously two interpetiolar lobes or filaments, four such lobes, or no lobes. Additionally, some species bear numerous setae or short filamentous appendages (e.g., *G. bieleri*, *G. liberiensis* E. M. A. Petit, *G. hirtiflora* Verdc.); the development of these setae varies within some species, so some individual plants may have these but others not (e.g., *G. bieleri*). And, many species of *Gaertnera* have the stipules further ornamented by ridges or wings. The stipule ridges are usually four and extend or arise from the ridges or wings that encircle the petiole. In many species, these stipule ridges or ribs extend upward along the sheath to the bases of the stipule lobes, either straight up from base to apex to form corners for the somewhat quadrate sheath (e.g., *G. obovata*), or angling to fuse in the middle of the sheath and outline an ornamented triangle in the basal portion of the stipule, sometimes then extending to the top of the sheath as one rib or sometimes separating again (e.g., *G. psychotrioides* (DC.) Baker). Some species have six longitudinal ribs on the stipule sheath (*G. brevipedicellata*).

The inflorescences are usually terminal on vegetative stems but may be displaced to pseudoaxillary (Robbrecht, 1988) by subsequent growth, or they are sometimes axillary and paired (e.g., *Gaertnera ob lanceolata*), terminal on relatively short branches arising from a well-developed main stem ("terminal on axillary branches"; e.g., *G. obovata*, *G. divaricata* (Thwaites) Thwaites), or terminal on flexuous, supra-axillary reproductive branches with reduced leaves (*G. diversifolia*; see discussion above). Van Beusekom (1967) diagrammed these various arrangements and postulated routes of developmental change that link them, although he posited no explanation for the supra-axillary inflorescence position. Following Robbrecht (1988), the inflorescences are considered terminal here when they are borne at the stem apex on one peduncle arising from the apical bud and also when additional inflorescence sections arise from the two axillary buds subtending the terminal bud. This latter arrangement has sometimes been called in Rubiaceae "tripartite" or "terminal and sessile." It

has also been referred to as "terminal and axillary" but is not here considered truly axillary in the sense of Robbrecht. The inflorescence position may vary within a species (e.g., *G. divaricata*), and the range of variation in this feature within a demonstrably monophyletic genus is notable.

The inflorescences are cymose or thyriform (Weberling, 1977) in arrangement, erect or sometimes pendulous (e.g., *Gaertnera trachystyla*, *G. diversifolia*, *G. pendula* Bojer), and generally dichasial in branching or, rarely, the higher-order axes may be scorpioid (*G. divaricata*). The inflorescence is usually multiflowered but may be reduced to a single flower (e.g., *G. ternifolia*, *G. madagascariensis* (Hook. f.) Malcomber & A. P. Davis) or few-flowered fascicle (e.g., *G. rosea* Thwaites ex Benth., *G. pauciflora* Malcomber & A. P. Davis), or contracted into a subcapitate head (e.g., *G. globigera*, *G. rotundifolia* Bojer) or spike (*G. spicata* K. Schum.). Van Beusekom (1967) diagrammed the various arrangements and postulated routes of development that link them. It is noteworthy that inflorescence morphology in general is homoplastic, and the hypothesized series of steps leading to the different forms is not supported by our best phylogenetic estimate for the genus. The general shape of the branched portion is usually characterized below species as corymbiform (i.e., rounded in outline), pyramidal (i.e., thyriform or paniculiform, generally conical in outline), or subglobose (i.e., congested-cymose to subcapitate). This range of variation in inflorescence arrangement is notable but similar to that found in some other Rubiaceae genera.

The inflorescences are sessile to usually pedunculate and bracteate with the bracts generally relatively small (0.1–5 mm long) but sometimes well developed (e.g., *Gaertnera cuneifolia*) and showy (e.g., *G. phyllostachya*). As in many Rubiaceae, there is often variation in the development and form of the bracts from the lower to upper nodes of the inflorescence, with the bracts "normally" shaped (i.e., reduced structures with generally elliptic to triangular shape) at the distalmost nodes but frequently resembling reduced subsessile leaves and/or reduced stipules at the basal nodes. Van Beusekom (1967) illustrated several distinctive bract forms and postulated the developmental changes that link them. The position of the bracteoles, at the base of the calyx and/or borne on the pedicel, does not appear to be taxonomically informative in *Gaertnera*, although it has been cited by some previous authors. The inflorescence axes and bracts are usually green but are attractive and bright white in a few species (e.g., *G. phyllosepala* Baker, *G. phyllostachya*). The flowers range from sessile or subsessile to usually at least shortly pedicellate.

The flowers are similar in general aspect and most details to many other Rubiaceae, except they are notable in their superior ovaries and their unusual variation in reproductive biology, which is either bisexual and heterodistylous or dioecious with the flower forms quite similar (e.g., *Gaertnera aphanodioica*) to distinctly different (e.g., *G. junghuhniana*). Van Beusekom (1967) illustrated much of the range of variation in corolla size, pubescence, and shape, anther position, and stigma and style shape and position. The breeding biology is discussed in more detail below. The flowers vary with unusual frequency among Rubiaceae within species, between populations, and on individual plants in the number of corolla lobes and stamens. The most common condition is used here to characterize most species, as done by previous authors. Detailed measurements are provided separately here for long-styled and short-styled flowers, or pistillate and staminate flowers. These usually are combined into a single measurement in Rubiaceae treatments, on the assumption that the flowers are generally similar. However, that assumption is rarely tested in general and the variation in floral form is unusually broad in *Gaertnera*, so these measurements seem useful to present here. In most species, the flowers do seem essentially similar in the two forms, but in some species there is a small difference that may be found in future studies to be significant.

The gamosepalous calyx is generally cup-shaped and varies from relatively short and truncate or 4- to 5-denticulate or shortly 4- to 5-lobed, to well developed with relatively large, sometimes bright white, sometimes fewer lobes (*Gaertnera phyllosepala*, *G. phyllostachya*). The measurements given here for width of the calyx describe the diameter of its top at anthesis, except for species with relatively large calyx lobes that are narrowed at the base, in which the diameter given is that of the top of the unlobed portion of the calyx. The relatively well-developed calyx lobes of some species (*G. phyllosepala*, *G. phyllostachya*) correspond to the "enlarged calyx lobes" of Robbrecht (1988). They have sometimes been called "calycophylls" (Delprete, 1996), "petaloid calyx lobes," or "semaphylls" but lack the differentiated stipe, broad blade, and relatively very large size of most such structures in Rubiaceae flowers. When present, the relatively well-developed calyx lobes may be generally equal to markedly unequal, with sometimes only one or few lobes developed on an individual flower. These enlarged calyx lobes may be developed on all the flowers of an inflorescence or only on a few flowers, and their number may vary on an individual plant (e.g., *G. phyllostachya*). The exterior of the calyx may be glabrous or variously pubescent and often is

similar in pubescence to the inflorescence axes. Its interior is usually glabrous but sometimes bears a ring of well-developed, uniform pubescence, or "hair-ring"; this structure was studied and is described for all species but does not seem to be taxonomically informative.

The corollas are salverform to funnellform at anthesis, with four or five lobes that are valvate in bud. The corollas are usually white but may be pink (e.g., *Gaertnera brevipedicellata*, *G. macrostipula*), red to orange (*G. spicata*), or blue (*G. pendula*). Corolla size in *Gaertnera* ranges from 2–30 mm long. The corollas may be glabrous (e.g., *G. pauciflora*, *G. phyllosepala*) or variously pubescent externally, and internally are usually either glabrous (e.g., *G. pauciflora*, *G. phyllosepala*) or densely villous in the upper half or third, with this pubescence sometimes extending onto the basal part of the internal or adaxial face of the lobes (e.g., van Beusekom, 1967: fig. 4). However, most of the internal faces of the corolla lobes are glabrous or, in a few species, glaucous. In most *Gaertnera* species, the corolla lobes are generally triangular to ligulate and flat, but in a few species they are thickened at the apex and prolonged into a hooked adaxial protuberance, and sometimes these apices are thickened abaxially enough to produce a sharply angled, pyramidal top to the flower bud instead of the smooth-sided, rounded to obtuse buds found in most species. *Gaertnera cooperi* is unique in its corolla lobes that are enlarged and cucullate at the apex and form a markedly enlarged and angled top on the flower bud. The corollas of *G. cooperi* are also unique within the genus in being fenestrate in the upper part of the tube. Fenestrate corolla tubes are known in several other Rubiaceae genera of various tribes and continents (Robbrecht, 1988; Piesschaert et al., 2001; but they have not been reported from *Pagamea*). The function of this corolla form is unknown.

The stamens are alternipetalous and inserted in the middle or upper part of the corolla tube, or rarely in the lower part in some small-flowered species. *Gaertnera calycina* was said (de Candolle, 1845) to have three alternipetalous anthers and the other two anthers borne opposite to the petals, but this has not been seen by us or remarked on by Verdcourt (1983), and perhaps was an artifact of the dried specimens studied. The anthers are bithecal, dorsifixed near the middle or sometimes the base, and open via lateral slits. No appendages on the connective or anthers have been seen by C.M.T., although Malcomber and Davis (2005) reported that these are found in the genus but did not mention any particular species. The size of the anthers ranges from 1.5–4 mm and is not described in detail here because it was not found to be

variable between floral forms of distylous species or to be informative for separating closely related species. The anthers may be exerted or included, and either position may be found in either flower form depending on the species. The long-styled and short-styled forms of distylous *Gaertnera* species do differ in the length of the filaments, often also in the position of the anthers (included vs. exerted), and rarely in the point of filament insertion on the corolla. The position of the anthers in each flower form of distylous species is similar to the position of the stigmas in the other form of that species. The staminodes of pistillate flowers may be reduced or similar to the stamens of the staminate flowers. The pollen was studied by Jansen et al. (1996a).

The ovary of *Gaertnera* is bilocular and secondarily superior as recently shown by Igersheim et al. (1994), with this superior position arising early in the development of the flower bud through upward intercalary growth of the ovary tissue. No *Gaertnera* species has an inferior ovary position. Igersheim et al. suggested that other Rubiaceae with superior or semi-inferior ovaries follow the same developmental pathway, but this appears not to be the case at least in another genus of Rubiaceae that was also previously placed in Loganiaceae, *Mitrasacmopsis* Jovet (Groeninckx et al., 2007). As noted above in the historical summary of the classification of this genus, the homology of this unusual ovary position has not always been interpreted correctly. The ovary is subglobose to ellipsoid and surrounded by a ring-shaped nectary. Each locule of the ovary has one erect basal ovule. The style is slender and glabrous or sometimes pubescent in the upper portion. The two stigmas are short to well developed and linear to clavate; they are sometimes reduced in staminate flowers. The long-styled and short-styled flowers differ also in the length of the style; as noted above, the position of the anthers in each floral form of distylous species is similar to the position of the stigmas in the other form of that species. The pistillodes of staminate flowers may be reduced or similar to the stigmas and style of the pistillate flowers.

The fruits of *Gaertnera* are succulent, drupaceous, globose to ellipsoid or rather didymous, and so far as observed, all black or violet-black at maturity. In a few species from Mauritius, the fruits have been reported to be whitened (Bojer, 1837), but this has not been seen by others (D. H. Lorence, pers. comm.). The fruits range in size from 4–20 × 3–16 mm, with size varying to some extent between species and also depending on the number of pyrenes produced, but as noted by van Beusekom (1967) the fruits do not show much infrageneric variation. The fruits contain one generally subglobose or two generally plano-convex

pyrenes; the number of pyrenes per fruit varies among individual flowers and is assumed to depend on pollination and other developmental factors affecting the number of ovules that develop in the individual fruits. The shape of the fruit also depends on the number of pyrenes that develop, as well as pyrene shape. The pyrene wall is elastic and “parenchyma-like” (Piesschaert, 2001), and the pyrene overall is smooth to ribbed, rugose, or deeply fissured. This form is usually visible on dried specimens because the fleshy fruit wall shrinks to the pyrene shape. Two marginal preformed germination slits and a third, median slit on the ventral surface have been seen in several *Gaertnera* species (S.T.M., pers. obs.); this is a common pattern in Rubiaceae (Piesschaert, 2001). The seed is generally elliptic to subglobose and is smooth to sometimes rugose or invaginated with ruminations that follow the shape of the pyrene wall (e.g., *G. aurea*, *G. cooperi*). These ruminations are shared with *Pagamea*, and thus considered plesiomorphic in *Gaertnera*. The endosperm is starchy.

REPRODUCTIVE BIOLOGY

The flowers of *Gaertnera* are insect pollinated, apparently mostly by bees and/or other generalist pollinators. There is apparently wide variation in pollination mode within the genus as shown by the wide range of flower size (e.g., *G. edentata* Bojer with corollas 17–35 mm long, *G. crassiflora* Bojer with corollas 38–40 mm long, *G. divaricata* with corollas 6.5–8 mm long), the variation in flower color (e.g., *G. spicata* with corollas red to orange-red, *G. edentata* with corollas white), and other aspects such as pendulous versus erect inflorescences, fenestrate versus entire corolla tubes, and truncate to large-lobed calyx limbs. The plants flower diurnally and last for a few days with usually only a few flowers open at one time on a particular inflorescence. Several species from Mauritius with relatively large, fleshy, white flowers and reportedly sweet odors (e.g., *G. edentata*, *G. hirtiflora*, *G. rotundifolia*) resemble flowers of other Rubiaceae that are nocturnal or crepuscular and may be moth pollinated; however, they are odoriferous in the middle of the day (D. H. Lorence, pers. comm.). The distylous species are protandrous.

The fleshy, drupaceous fruits of *Gaertnera* are presumably similar to those of other Rubiaceae in being bird dispersed; however, no active dispersal of *Gaertnera* fruits was observed during this study, and no published dispersal observations have been found.

Gaertnera is either distylous (Fig. 2) or dioecious (Fig. 4; Malcomber, 2000, 2002). Van Beusekom (1967) suggested that some plants of *G. vaginans* are homostylous and bisexual, but this has not been

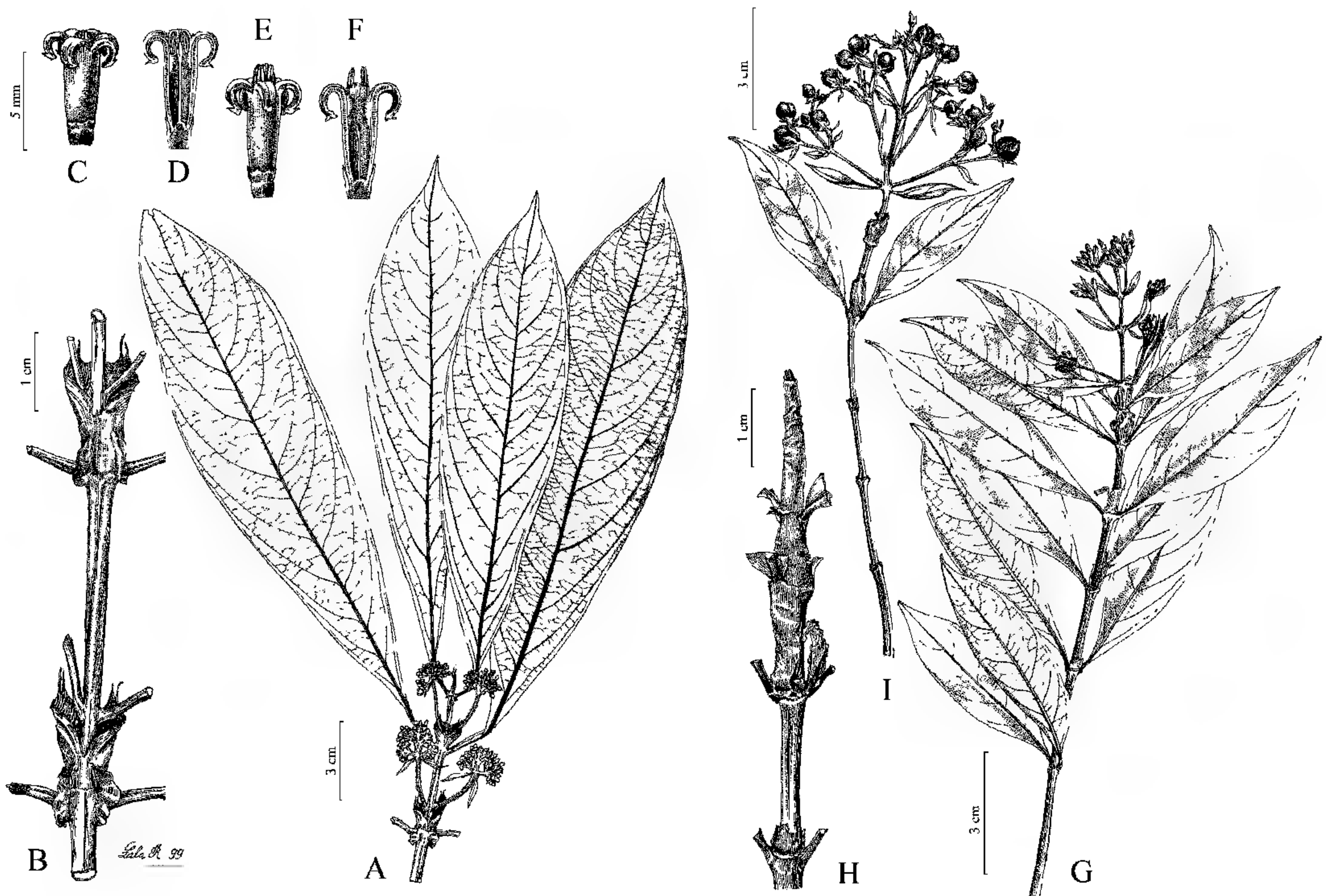

Figure 4. A–F. *Gaertnera oblanceolata* King & Gamble. —A. Flowering branch. —B. Portion of stem with petiole bases and stipules. —C. Pistillate flower. —D. Pistillate flower in cross section. —E. Staminate flower. —F. Staminate flower in cross section. G–I. *Gaertnera raphaelii* Malcomber. —G. Flowering branch. —H. Portion of stem with petiole bases, stipules, and stem apex. —I. Fruiting branch. C–F to same 5-mm scale. A–F based on *Malcomber 3039*; G–I based on *Malcomber 2875*.

confirmed by us. *Gaertnera aphanodioica* (Fig. 5A–F) is notable in being morphologically apparently homostylous, but functionally dioecious based on pollination studies by S.T.M. in Berakas Forest Reserve, Brunei, in 1998; collections from this population were regarded by van Beusekom (1967) as hermaphroditic and homostylous forms of *G. vaginans*. All the other species for which breeding biology is known are either evidently dioecious or distylous. The breeding biology of several species cannot be determined from the information available; such species from Africa, Madagascar, the Mascarene Islands, and Sri Lanka are presumed to be probably distylous, and the unknown species from southeastern Asia are expected to be eventually demonstrated to be dioecious. The evolutionary aspects of the breeding biology of *Gaertnera* are discussed further below.

BIOGEOGRAPHY, HABITAT, AND DISTRIBUTION

As circumscribed here, species of *Gaertnera* are regional endemics in Sri Lanka (five species and one hybrid), southeastern Asia (16 species), Africa (12 species), Madagascar (26 species), and the Mascarene Islands (nine species in Mauritius, one species in Réunion). Accordingly, regional keys are presented to

the species of the genus. The relationships among the species are not entirely clear (Malcomber, 2002), but the geographic patterns suggest the genus has a history of radiation within newly colonized regions, especially on islands such as Madagascar, Mauritius, Sri Lanka, and Borneo. Robbrecht (1996), in his survey of African Rubiaceae biogeography, characterized *Gaertnera* in the category of “12 Palearctic Genera, 122 mainly present in Africa and/or Madagascar,” apparently based in large part on the work of Petit (1959a) and van Beusekom (1967). More species are recognized here in all of these regions but particularly in Asia.

Within a particular biogeographic region, the *Gaertnera* species for which information is available show a consistent breeding biology, distylous through most of the range of the genus and dioecious in Southeast Asia. Van Beusekom (1967) recognized species of broad geographic range with mixed distylous-dioecious breeding biology, but these circumscriptions are not supported by the data or the species descriptions on which this treatment is based, as discussed in detail below for the *G. vaginans* complex.

The 12 African species of *Gaertnera* are found from Senegal in the northwestern part of the continent to

Zambia in its central southeastern region, from sea level to 1720 m (Fig. 1). The most widespread species is *G. paniculata*, which is found throughout this range. Most of the species are restricted to West or Central Africa, and most are found below 1000 m elevation. Presumably, the apparently disjunct distributions of species that appear to “jump over” some countries are artifacts of limited specimen representation rather than the actual range (e.g., *G. longivaginalis* (Schweinf. ex Hiern) E. M. A. Petit documented in the Democratic Republic of the Congo, Cameroon, and Angola but not Gabon). In the phytogeographic classification of Takhtajan (1986), *Gaertnera* is found in the Guineo-Congolian and Sudano-Zambesian regions, with all of its African species found in the first region and two additionally ranging into the second. In the more detailed phytogeographic classification of White (1993), all 12 of the African species of *Gaertnera* are found in the “Guineo-Congolian regional centre of endemism,” with 10 species restricted to this region, while the other two species also range into the “Guineo-Congolia/Sudania regional transition zone” (*G. longivaginalis*, *G. paniculata*) and the “Guineo-Congolia/Zambesia regional transition zone” (*G. longivaginalis*, *G. paniculata*), and only *G. paniculata* further ranges into the “Sudanian” and “Zambeian regional centres of endemism.” The species that are only found in the “Guineo-Congolian regional centre of endemism” are all further restricted to the west (*G. aurea*, *G. cooperi*, *G. liberiensis*) or east (*G. bieleri*, *G. eketensis*, *G. gabonensis* Malcomber, *G. letouzeyi* Malcomber, *G. leucothyrsa*, *G. spicata*, *G. trachystyla*) of the Dahomey Gap. Some changes to White’s phytogeographic classification have subsequently been proposed, but as detailed by Friis (1998), these affect mainly the Afromontane regions and do not touch on the African range of *Gaertnera*. Robbrecht (1996) recognized several generic distribution patterns of African Rubiaceae; *Gaertnera* generally agrees with his “Africa-wide” distribution except it is not present in East Africa.

In Asia, six species of *Gaertnera* and one presumed natural hybrid are restricted to Sri Lanka, while 16 species are found in southeastern continental Asia, Borneo, and Sumatra (Fig. 1). On Sri Lanka, *Gaertnera* is found at 50–2000 m elevation in wet evergreen forests, generally in the southwestern and central part of the island; *G. vaginans* is the most commonly collected species. Sri Lanka was classified phytogeographically by Takhtajan (1986) in the Indian region, which he considered a separate region from southeastern Asia. In southeastern Asia, *Gaertnera* ranges from sea level to 2750 m elevation, and 14 species are restricted to the region of Peninsular Malaysia,

Borneo, and Sumatra, classified by Takhtajan in the Malesian region. *Gaertnera junghuhniana*, the most commonly collected species in this region, is mainly distributed in the Malesian region but is also found in peninsular Thailand, which Takhtajan classified as part of the adjacent Indochinese region; in contrast, *G. sralensis* is mainly distributed in the Indochinese region but is also found in Peninsular Malaysia in the Malesian region.

Gaertnera has its center of species richness (as well as morphological diversity) in Madagascar and the Mascarene Islands (Fig. 1), which phytogeographically comprise most of the Madagascan region of Takhtajan (1986). Here, *Gaertnera* is found mainly on Madagascar (26 or possibly 27 species) but is also well represented on Mauritius (nine species) and Réunion (one common species), with all the species currently each known from a single one of these islands. Several species of *Gaertnera* of Mauritius may have grown in Madagascar in historical times (e.g., *G. crassiflora*), or these reports may be labeling errors. On Mauritius, *Gaertnera* species are found in wet forests and heathlike, “groundwater laterite” vegetation at 50–800 m, with *G. psychotrioides* the most commonly collected species. *Gaertnera vaginata* is the only species known from Réunion, where it grows in wet forests at 50–1800 m.

The geological substrates of Madagascar were mapped and included in vegetation analyses by Du Puy and Moat (1998, 2003); *Gaertnera* species in Madagascar are generally found on metamorphic and igneous basement rocks, except a few species that grow additionally to exclusively on sedimentary substrates such as alluvial deposits (e.g., *G. mada-gascariensis*) or unconsolidated sands (e.g., *G. guillotii* Hochr.). Du Puy and Moat also classified the vegetation types of Madagascar; *Gaertnera* is found here in evergreen humid forests, which are distributed along the entire eastern part of the island, through the east-central highlands region (although very little natural vegetation remains here) and westward through the mountainous northern region. *Gaertnera* grows in Madagascar at 0–2000 m, in Du Puy and Moat’s “coastal forest (eastern),” “evergreen, humid forest: low altitude,” “evergreen humid forest: mid altitude,” and “evergreen humid forest: lower montane” zones. A few *Gaertnera* species here are found only at ca. 300 m elevation or below (*G. cardiocarpa*, *G. drakeana* Aug. DC., *G. hispida* Aug. DC., *G. schatzii*), but most of the species are found at higher elevations. By far, the most commonly encountered species is the widespread, morphologically variable *G. obovata*, in particular its variety *sphaerocarpa* (Baker) Malcomber. As noted by Davis and Bridson (2003), *Gaertnera* is one of the most commonly encountered

genera of Rubiaceae in mature, well-preserved forests, although it is not often found in secondary vegetation and this is not a relatively species-rich Rubiaceae genus in Madagascar. Gautier and Goodman (2003) recently reviewed the phytogeography of Madagascar and noted that although the island's flora is known for its high degree of endemism, Paleotropical genera such as *Gaertnera* as well as pantropical genera also comprise an important part of the flora. Gautier and Goodman recognized five phytogeographic regions; *Gaertnera* is found in three of these: the Eastern region, the Central region, and the Sambirano region. Several *Gaertnera* species are restricted to only one of these regions and are known from only a small range here within the respective region (e.g., *G. schatzii*, *G. brevipedicellata*, *G. bambusifolia* Malcomber & A. P. Davis), while a few species are found in all three of these regions (e.g., *G. obovata*).

DIVERSIFICATION AND EVOLUTION IN THE GENUS

PHYLOGENETIC RELATIONSHIPS AND ORIGIN OF *GAERTNERA*

The Bayesian phylogenetic analysis of 31 *Gaertnera* species with *Pagamea guianensis* and two *Morinda* species as outgroups estimated a well-supported (99% posterior probability [PP]) *Gaertnera* clade, but only seven well-supported (> 95% PP) clades within the genus because of limited nucleotide sequence divergence among sampled species in the ITS, *PepC-L*, and *PepC-S* data sets. *Gaertnera cooperi* is estimated as sister to all other sampled species, followed by another African species, *G. longivaginalis*. The position of the remaining sampled African species, *G. paniculata*, is unresolved in a clade containing sampled species from Madagascar, Mauritius, Southeast Asia, and Sri Lanka. A well-supported clade of Malagasy species (98% PP), excluding *G. lowryi* Malcomber, is found to be sister to a clade of sampled Mauritian species. *Gaertnera lowryi* is found to be sister to a well-supported clade of all the sampled Southeast Asian and Sri Lankan species, suggesting that the progenitor of the Sri Lankan and Southeast Asian species originated in northeastern Madagascar (e.g., the Masoala Peninsula). However, this sister relationship is not well supported (92% PP), so additional characters and *Gaertnera* species will need to be included to test this hypothesis. Sampled Southeast Asian species from Peninsular Malaysia, Singapore, and western Sarawak form a well-supported clade (99% PP) that is unresolved relative to the other Sri Lankan and Southeast Asian species. Sampled Sri Lankan species do not form a single clade, although a well-supported (97% PP) sister relationship is estimated between *G. ternifolia* and *G. walkeri*.

Similar to the results of Malcomber (2002) and Malcomber and Davis (2005) with data sets with common nucleotide sequence data, our phylogenetic analysis estimated an African origin for *Gaertnera* followed by a limited number of dispersal events from Africa to Madagascar, Madagascar to Mauritius, and Madagascar to Sri Lanka/Southeast Asia. Molecular clock analyses estimated that these dispersal events and radiation of the genus occurred within the last 5–5.5 million years (Malcomber, 2002).

MORPHOLOGICAL AND REPRODUCTIVE DIVERSIFICATION

Gaertnera is notable in Rubiaceae and also in the higher plants in the plasticity of morphology and breeding systems within a group of closely related, relatively recently derived species. The phenological plasticity and the varied directions in which selection has pushed it are remarkable for both the range and number of novelties (e.g., the fenestrate corollas of *G. cooperi*, the spiciform inflorescence of *G. spicata*, the enlarged calyx lobes of *G. phyllostachya*) and the repeated derivation of unusual morphological features in species of different regions (e.g., the relatively large campanulate stipules of *G. obesa* and *G. monstrosa*; the pendulous supra-axillary inflorescences bearing reduced leaves of *G. inflexa* and *G. diversifolia*). It should also be noted that several morphological features do not vary in *Gaertnera* as much as in some other Rubiaceae genera of comparable size, in particular number of ovary locules and stigmas, corolla and fruit colors, and the size of the plants (all *Gaertnera* species are small trees or shrubs up to 15 m tall).

Notable morphological variation in *Gaertnera* includes leaf size, which ranges from 0.5–60 cm long, and stipule form. The stipules are always united into at least a short sheath, but are variously membranous to coriaceous, calyptrate to tubular or funnellform, and caducous to persistent, with only the basal portion to the entire stipule persisting. The stipule tube is variously ridged, ornamented with ribs and/or well-developed wings, or smooth, and the stipule apex is entire, lobed, possessing a combination of lobes and setae, or with only setae. Most *Gaertnera* species have terminal inflorescences borne on principal branches, but *G. inflexa*, *G. diversifolia*, *G. oblanceolata*, and *G. divaricata* have inflorescences on axillary or supra-axillary branches. Inflorescence arrangement varies from corymbiform-cymose to lax and thyrsiform, capitate, or reduced to a few-flowered cyme or solitary flowers. Calyx lobes are usually relatively small and deltate to linear, but are sometimes filiform or expanded into petaloid white structures that function to attract pollinators. The corollas are generally white

in all but one species, and range in size from 2–30 mm long.

Species of *Gaertnera* appear to hybridize, in some cases perhaps frequently, as in some other Rubiaceae genera (e.g., *Cinchona* L.; Andersson, 1998). In particular, a distinctive group of plants that have long been regarded as a separate species are considered a hybrid here, *G. ×gardneri*, which is intermediate but somewhat variable in characters and grows in the contact zone of its two presumed parents, *G. ternifolia* and *G. walkeri*, on Adam's Peak. Several species from Madagascar also appear to hybridize (e.g., *G. phanerophlebia*, *G. humblotii* Drake). Whether these hybrids are fertile is unknown; if so, this process may be part of the reason for the diversification and close species relationships seen in *Gaertnera*.

As discussed above and elsewhere (Malcomber, 2002), species of *Gaertnera* may be either dioecious or distylous, and the genus is also one of only nine reported cases in which dioecy has apparently followed a predicted pathway and evolved from distylous ancestors (Muenchow & Grebus, 1989).

The available evidence—biogeography, molecular sequence data, and morphology—shows that this notable morphological diversity has evolved relatively rapidly and also that several unusual features of individual *Gaertnera* species have evolved more than once, in parallel, within the genus, in different regions presumably in response to similar selection pressures. Thus, *Gaertnera* provides an example of the ways in which tropical Rubiaceae have diversified, shows the dynamic environment in which tropical plants live, and provides an object lesson for systematists about the nature and “informativeness” of both morphological and molecular characters.

THE *GAERTNERA VAGINANS* COMPLEX

Van Beusekom (1967), in his revision of Asian *Gaertnera*, adopted a broad species concept. In particular, he circumscribed *G. vaginans* as one widespread, morphologically and biologically variable species with two subspecies and included in it plants of Africa, Madagascar, Sri Lanka, and Southeast Asia with cylindrical stipules that closely encircle the stems, subcapitate to diffusely cymose inflorescences, 5-merous flowers, reduced calyx lobes, and variously distylous, homostylous, and dioecious breeding systems. His subspecies *vaginans* comprised all the distylous plants of this group and all the plants of Africa, Madagascar, and Sri Lanka; his subspecies *junghuhniana* (Miq.) Beusekom comprised all the dioecious plants of this group and all the plants of Southeast Asia including Borneo and the Indonesian archipelago. Thus, van Beusekom's circumscription of

G. vaginans resulted in a single species that was distinguished by a set of characters that are widespread and perhaps ancestral within the genus. His *G. vaginans* additionally was distributed across several broad biogeographic regions and notably polymorphic in breeding system, and thus questionable as to the reproductive cohesion of the regional populations.

Such broadly diagnosed widespread taxa that are morphologically similar in a general way yet polymorphic in several features are recognized in most taxonomic studies of plant groups. Such polymorphic taxa are sometimes recognized when the observed morphological variation is not considered significant (e.g., Vink [1970] grouped 39 local “entities” into a broadly circumscribed *Drimys piperita* Hook. f. [Winteraceae]), and sometimes they result from a lack of data adequate to support further subdivision within the group (e.g., Maldonado [2005] reduced half the previously described species of *Elaeagia* Wedd. [Rubiaceae] to synonymy based on a principal coordinates analysis of characters of individual specimens that failed to distinguish diagnosable groups; Andersson [1998] recognized several broadly circumscribed, variable species of *Cinchona* diagnosed by a unique combination of common characters of the genus). Alternatively, such morphologically variable sets of plants are sometimes treated as numerous narrowly circumscribed species, in some cases linked by intermediate or presumed hybrid specimens (e.g., Andersson [1998] also recognized several morphologically well-marked, geographically restricted *Cinchona* species among populations previously included in other species, and listed intermediate specimens).

White (1998) addressed this situation and described such widespread polymorphic taxa as ochlo-species, a term he defined as: “A very variable (polymorphic) species, whose variation, though partly correlated with ecology and geography, is of such complex pattern that it cannot be satisfactorily accommodated within a formal classification.” Cronk (1998) reviewed several cases that can be considered ochlo-species, compiled a list of 10 traits that characterize and help recognize ochlo-species, and concluded that it is not always clear which are phenotypically plastic species and which result from the synthesis of inadequate data.

Gaertnera vaginans as circumscribed by van Beusekom (1967) has several of the traits of ochlo-species identified by Cronk; in particular, it is geographically and ecologically widespread; its character states seem to be only partially correlated with geography; similar variants appear to be found in widely separated localities; and it has a long taxonomic synonymy. Characterizing van Beusekom's

G. vaginans as an ochlopecies suggests that it deserves reconsideration and that additional data are needed for this. Here, this is reviewed using molecular data incorporated with newly compiled morphological data based on additional collections made since 1968, and a different, more closely defined species concept (outlined in the Methods section).

The molecular sequence data indicate that plants of van Beusekom's "*Gaertnera vaginans*" do not form a single clade, but instead are a polyphyletic group with members distributed among several of the clades within *Gaertnera* (Fig. 3). This supports the classification based on morphology, which separates van Beusekom's "*G. vaginans*" into 12 species, each with more limited geographic distribution and morphological variation (Table 2), with five of these newly described here: *G. alstonii* Malcomber, *G. aphanodioica*, *G. arenaria*, *G. belumutensis*, *G. capitulata*, *G. junghuhniana*, *G. kochummenii*, *G. longivaginalis*, *G.*

paniculata, *G. ramosa* Ridl., *G. sralensis*, and *G. vaginans*. A key to the species recognized within this group is presented below.

The majority of these species are found in Southeast Asia, where van Beusekom's study was focused; thus, the morphological variation that was problematic for this classification is indeed greatest in this region, although *Gaertnera arenaria* of Madagascar as circumscribed here is also widely variable and perhaps represents an ochlopecies on a smaller scale (resolution of this is beyond the scope of the present work). Thus, in this case the addition of more data leads to the segregation of this polymorphic taxon into more numerous and more narrowly delimited species that are more comparable in their distinguishing features and variability to other species of *Gaertnera*, and thus more broadly testable across the genus. This new classification better elucidates some of the evolutionary radiation within *Gaertnera*.

KEY TO SPECIES OF THE *GAERTNERA VAGINANS* COMPLEX

- 1a. Stems and stipules pilosulose to hirtellous, tomentulose, and villous or stipules sometimes puberulent; plants dioecious.
 2a. Leaves elliptic-oblong to oblanceolate or elliptic; inflorescence corymbiform; peduncles 3–5 cm long; Borneo 2. *G. alstonii*
 2b. Leaves elliptic to oblanceolate; inflorescence subglobose, sessile or with peduncles to 1.4 cm long; Borneo 11. *G. capitulata*
- 1b. Stems and stipules glabrous or puberulent, or stipules sometimes pilosulose in *G. longivaginalis*; plants distylous or dioecious.
 3a. Inflorescences subglobose, sessile or with peduncles to 3.5 cm long.
 4a. Plants drying with green to grayish green cast; continental Southeast Asia 64. *G. sralensis*
 4b. Plants drying with orange cast.
 5a. Calyx truncate or with lobes to 0.3 mm long; continental Southeast Asia 7. *G. belumutensis*
 5b. Calyx lobes 1–3.5 mm long; continental Southeast Asia 35. *G. kochummenii*
- 3b. Inflorescences corymbiform to pyramidal, sessile or with peduncles to 6 cm long.
 6a. Plants dioecious, with unisexual flowers (flowers appearing homostylous in *G. aphanodioica*).
 7a. Stipules drying membranous, with lobes 1–2.5 mm long; inflorescences several-flowered, with ca. 5 to 10 flowers; continental Southeast Asia 57. *G. ramosa*
 7b. Stipules drying chartaceous, with lobes 1–7 mm long; inflorescences many-flowered, with more than 10 flowers.
 8a. Corolla white, tube 6–9 mm long; Borneo 3. *G. aphanodioica*
 8b. Corolla pale green to white, tube 2.5–5 mm long; continental Southeast Asia . . . 34. *G. junghuhniana*
- 6b. Plants distylous, with bisexual flowers.
 9a. Stipules drying membranous, with lobes 1–8 mm long; corolla tube 4–6 mm long; West and Central Africa 40. *G. longivaginalis*
 9b. Stipules drying chartaceous, with lobes 0.5–5 mm long.
 10a. Corolla tube 3–4 mm long, externally densely puberulent or tomentose; stipule lobes 0.5–1.2 mm long; West and Central Africa 50. *G. paniculata*
 10b. Corolla tube 4–16 mm long, externally glabrous, scabrous, or sparsely puberulent; stipule lobes 0.5–5 mm long.
 11a. Corolla tube 10–16 mm long; stipule lobes 2.5–5 mm long; Madagascar . . . 4. *G. arenaria*
 11b. Corolla tube 4–6 mm long; stipule lobes 0.5–2.5 mm long; Sri Lanka 67. *G. vaginans*

TAXONOMIC TREATMENT

Gaertnera Lam., Tabl. Encycl. 1: 379, t. 167, 13 Feb. 1792, nom. cons., non *Gaertnera* Schreb., 1789, nom. rej., Malpighiaceae; nor *Gaertneria* Medik., 1798, nom. rej., Asteraceae; nor *Gaertneria* Neck., 1789, nom. inval., Gentianaceae; nor *Gaertnera* Retz., 1791, nom.

rej., Campanulaceae. TYPE: *Gaertnera vaginata* Lam.

Sykesia Arn., Nova Acta Phys.-Med. Acad. Caes. Leop.-Carol. Nat. Cur. 18: 351. 1836. *Gaertnera* subg. *Sykesia* (Arn.) Benth., J. Proc. Linn. Soc. 1: 112. 1857. TYPE: *Sykesia koenigii* Arn., nom. illeg. superfl. — *Gaertnera vaginans* (DC.) Merr.

Fructesca DC. ex Meisn., Pl. Vasc. Gen. 1: 259, 2: 168. 1840. TYPE: *Fructesca mauritiana* DC. ex Meisn.

Table 2. Contrasting taxonomic treatments of *Gaertnera vaginans* (DC.) Merr. s.l.

Breeding system	Character states of Malcomber										Taxonomic treatments	
	Plant drying orange or yellow?	Leaf shape	Leaf pubescent or glabrous?	Stipule wings prominent?	No. of flowers per inflorescence and shape	Calyx lobe shape	Corolla length	Anthers and stigma equal?	Malcomber (2004)	van Beusekom (1967)		
Dioecious	yes	oblong	pubescent	yes	many, domed	triangular, small	mature corolla unknown		<i>Gaertnera alstonii</i>	<i>G. vaginans</i> subsp. <i>junghuhniana</i>		
Dioecious	no	elliptic-oblancoelate	glabrous	no	many, domed	+ truncate	6–8 mm long	yes	<i>G. aphanodioica</i>	<i>G. vaginans</i> subsp. <i>junghuhniana</i>		
Dioecious	yes	elliptic	glabrous	no	many, globose	+ truncate	mature corolla unknown		<i>G. belumutensis</i>	<i>G. vaginans</i> subsp. <i>junghuhniana</i>		
Dioecious	no	elliptic to oblancoelate	pubescent	yes	many, globose	triangular, small	7.5–8.5 mm long	no	<i>G. capitulata</i>	<i>G. vaginans</i> subsp. <i>junghuhniana</i>		
Dioecious	no	linear, lanceolate-oblancoelate	usually glabrous	no	few or many, domed	+ truncate	2.5–5 mm long	no	<i>G. junghuhniana</i>	<i>G. vaginans</i> subsp. <i>junghuhniana</i>		
Unknown	yes	elliptic	pubescent	no	many, domed	ovate, prominent	mature corolla unknown		<i>G. kochummenii</i>	<i>G. vaginans</i> subsp. <i>junghuhniana</i>		
Dioecious	no	elliptic-oblancoelate	glabrous	no	few, domed	+ truncate	5–10 mm long	no	<i>G. ramosa</i>	<i>G. vaginans</i> subsp. <i>junghuhniana</i>		
Dioecious	no	elliptic	glabrous	no	few to many, globose	triangular	3–4 mm long	no	<i>G. stalensis</i>	<i>G. vaginans</i> subsp. <i>junghuhniana</i>		
Distylous	no	elliptic to oblong	glabrous	no	many, conical	+ truncate	10–16 mm long	no	<i>G. arenaria</i>	<i>G. vaginans</i> subsp. <i>vaginans</i>		
Distylous	no	elliptic to oblancoelate	glabrous	no	few or many, domed	linear, up to 5 mm long	4–6 mm long	no	<i>G. longivaginalis</i>	<i>G. vaginans</i> subsp. <i>vaginans</i>		
Distylous	no	oblong to elliptic	glabrous	no	many, domed	+ truncate	2.5–4 mm long	no	<i>G. paniculata</i>	<i>G. vaginans</i> subsp. <i>vaginans</i>		
Distylous	no	elliptic to obovate	glabrous	no	many, conical or domed	+ truncate	4–5.5 mm long	no	<i>G. vaginans</i>	<i>G. vaginans</i> subsp. <i>vaginans</i>		

Gaertnera sect. *Aetheonoma* A. DC., Prodr. 9: 34. 1845.
Aetheonoma Meisn. ex Steud., Nomencl. Bot., ed. 2,
651. 1841, nom. nud., pro syn. TYPE: *Gaertnera*
calycina Bojer.

Pristidia Thwaites, Enum. Pl. Zeyl. 2: 149. 1859. TYPE:
Pristidia divaricata Thwaites — *Gaertnera divaricata*
(Thwaites) Thwaites.

Hymenocnemis Hook. f., in Benth. & Hook. f., Gen. Pl. 2:
132. 1873. TYPE: *Hymenocnemis madagascariensis*
Hook. f. — *Gaertnera madagascariensis* (Hook. f.)
Malcomber & A. P. Davis.

Gaertnera ser. *Densiflorae* K. Schum., Nat. Pflanzenfam. 4(4):
124. 1891. TYPE: *Gaertnera crassiflora* Bojer.

Gaertnera ser. *Laxiflorae* K. Schum., Nat. Pflanzenfam. 4(4):
124. 1891, nom. illeg. TYPE: not designated. (This
series explicitly included the type species of the genus,
and thus is correctly called *Gaertnera* ser. *Gaertnera*.)

Trees or shrubs, up to 15(–20) m tall, glabrous to variously pubescent, sometimes drying grayish green, brown, gray, chestnut, reddish brown, or with a distinctive orange cast. Branches flattened to terete or quadrangular, 0.5–15 mm diam.; internodes 0.1–26 cm, smooth or with 2 to 4 longitudinal ribs, sometimes corky (*Gaertnera alata* Bremek. ex Malcomber & A. P. Davis). Leaves sessile to petiolate, decussate, paired or rarely ternate, isophyllous to slightly anisophyllous; blade 0.5–55 × 0.1–20 cm, linear-lanceolate to elliptic, elliptic-oblong, or cuneiform, margins flat or infrequently crisped; secondary veins visible or sometimes not visible abaxially, eucamptodromous, spreading and arched or infrequently nearly straight and ascending at an acute angle; domatia absent or present as pilosulose or hirtellous, tuft- or crypt-domatia in axils of secondary veins; petioles 0.2–10 cm, smooth to occasionally furrowed or rarely winged, smooth or usually encircled on sides and below by ridges or wings, these often extending onto stipules. Stipules 0.1–75 mm, tubular and open at top in bud to fused at top and calyprate, cylindrical to infrequently funnel-shaped, entire or splitting along 1 side to form a spathaceous structure, splitting on 2 sides to form 2 usually intrapetiolar segments, or rarely splitting on 4 sides into 4 spatulate parts (*G. furcellata* (Baill. ex Vatke) Malcomber & A. P. Davis, *G. microphylla*), drying membranous to coriaceous, variously caducous, deciduous through fragmentation, or persistent, usually with 4 longitudinal ribs or wings arising below petioles and extending along sheath to lobes, sometimes with 2 additional ribs or wings; apex entire or with the 1 to 4 incisions described above, marcescent (i.e., becoming hardened) to fragmenting or infrequently persistent; lobes none or 4, up to 20 mm, deltate to filiform; additional setae none or several to numerous, to 20 mm. Inflorescences terminal on developed stems, sometimes borne on short axillary stems, or rarely axillary or terminal on supra-axillary stems, cymose to compound-cymose, paniculi-

form, subcapitate, reduced to 1 or a few flowers, or rarely spiciform, erect to occasionally pendulous, sessile to pedunculate, green, white, or pink, bracteate or rarely ebracteate (*G. alata*); peduncle to 15 cm; branched portion up to 25 × 30 cm, pyramidal to corymbiform-rounded, subglobose, or rarely cylindrical, branched to as many as 6 orders, lax to congested; axes dichasial or rarely scorpioid (*G. divaricata*); bracts subtending basalmost axes triangular to linear or sometimes resembling reduced leaves or stipules (*G. microphylla*), rarely grouped into an involucre (*G. cuneifolia*, *G. microphylla*); bracts subtending higher-order axes up to 30 mm, deltate to linear, ovate, or trifid, usually grading in size and shape between basalmost bracts and bracteoles; bracteoles reduced to developed, inserted on pedicel and/or at base of calyx, rarely enlarged and bright white (*G. phyllosepala*, *G. phyllostachya*). Supra-axillary reproductive branches rarely present (*G. diversifolia*, *G. inflexa*), paired, flexuous, with leaves well developed to reduced. Flowers sessile to pedicellate, 4- to 5(6)-merous, dioecious or bisexual and heterodistylous. Calyx limb cup-shaped, urceolate, or campanulate, 1–20 mm wide, outside glabrous or variously pubescent, inside sometimes with a distinct ring of trichomes, truncate to denticulate or lobed, lobes rounded to triangular or linear, equal to markedly unequal, up to 30 mm, sometimes petaloid in color and texture (*G. phyllosepala*, *G. phyllostachya*); corolla white or infrequently pink, red, orange, or blue, clavate to rhomboidal or obclavate in bud, at anthesis salverform, infundibuliform, or campanulate, 2–30 mm, outside glabrous or variously pubescent, inside glabrous or villous inside tube, tube entire or rarely fenestrate (*G. cooperi*), lobes 1–10 mm, narrowly triangular to ovate-oblong, glabrous adaxially, apically rounded to acute or rarely expanded and cucullate (*G. cooperi*), abaxially smooth or rarely with a thickened subapical appendage (*G. edentata*); stamens inserted in corolla tube, anthers 1.5–4 mm, narrowly oblong, dithecal, dehiscent by longitudinal slits, sessile or with developed filaments to 8 mm, in long-styled flowers positioned below the stigmas and included to partially exerted, in short-styled flowers positioned above the stigmas and included to exerted, in staminate flowers positioned near middle of corolla tube to exerted, in pistillate flowers staminodes present or absent, positioned in lower part of corolla to corolla throat. Ovary superior, 2-locular, 2-celled, with 1 erect basal ovule in each cell; style filiform, glabrous or pubescent, stigmas 2, linear-clavate, often flattened, in long-styled flowers these positioned above the anthers and exerted, in short-styled flowers these positioned below the anthers and included, in staminate flowers pistillodes developed or reduced and positioned in lower part to middle

of corolla tube, in pistillate flowers these developed and positioned in lower to upper part of corolla tube. *Fruit* a drupe, blue to violet-black or reportedly sometimes whitened, globose to ellipsoid, obovoid, or didymous, smooth or infrequently ridged, 5–28 × 5–16 mm, glabrous or rarely pubescent; pyrenes 2 per drupe or sometimes 1 apparently by abortion or incomplete pollination, spherical or hemispherical to wedge-shaped, ± smooth to finely fissured, rugose, and/or deeply fissured, endosperm entire to invaginated or ruminated.

Distribution. Sixty-nine species and one presumed hybrid in evergreen moist vegetation, usually in forest understory, at 0–2000 m in Africa (Senegal, Sierra Leone, Guinea, Benin, Mali, Liberia, Côte d'Ivoire, Burkina Faso, Ghana, Togo, Nigeria, Cameroon, Central African Republic, Democratic Republic of the Congo, Republic of the Congo, Equatorial Guinea, Gabon, Angola, Zambia), Madagascar, the Mascarene Islands (Mauritius, Réunion), Sri Lanka, and continental Southeast Asia (Thailand, Cambodia, Vietnam, Malaysia), Sumatra (Indonesia), and Borneo (Brunei, Malaysia, Indonesia).

REGIONAL KEYS TO *GAERTNERA* SPECIES

KEY TO *GAERTNERA* SPECIES IN AFRICA

- 1a. Inflorescence spiciform to narrowly pyramidal, unbranched or branched to 1 to 2 orders with axes short and congested; flowers sessile to subsessile; corolla red to orange-red outside; stipule lobes 5–15 mm long; Gabon, in coastal forests 63. *G. spicata*
- 1b. Inflorescence cymose to paniculiform, pyramidal, or corymbiform, with axes and/or pedicels developed, branched to 1 to 6 orders; flowers sessile to pedicellate; corolla white; stipule lobes 0–10 mm long; widespread in Africa.
 - 2a. Stipules with several to numerous setae 0.5–9 mm long at apex, in addition to the 4 stipule lobes.
 - 3a. Calyx limb lobed, lobes 0.8–4.5 mm long; stems pilosulose and/or hirtellous at least when young 8. *G. bieleri* p.p.
 - 3b. Calyx limb truncate to shortly lobed, lobes to 0.6 mm long; stems puberulent to glabrous.
 - 4a. Bark with longitudinal fissure or striations; stipules glabrous; inflorescence corymbiform, with branched portion 3–5.5 × 3–7 cm 21. *G. eketensis*
 - 4b. Bark apparently smooth; stipules pilosulose; inflorescence narrowly pyramidal, with branched portion 1.8–5 × 1.2–3 cm 38. *G. liberiensis*
 - 2b. Stipules without setae at apex, without lobes or with 2 or 4 developed lobes.
 - 5a. Stipules with ridges or wings not extending below the petioles, the stems merging smoothly into the petiole base or the base encircled by a thin, ciliolate, skirt-like flap.
 - 6a. Pedicels 1–9 mm long; inflorescences deflexed to pendulous, with axes mostly spreading at ca. 90 degrees 66. *G. trachystyla* p.p.
 - 6b. Pedicels 0–1 mm long; inflorescences ascending, with axes mostly ascending.
 - 7a. Corolla tube 4–6 mm long, lobes 2.5–5 mm long; stipules drying membranous . . . 40. *G. longivaginalis*
 - 7b. Corolla tube 2.5–4 mm long, lobes 1.5–2.5 mm long; stipules drying chartaceous . . . 50. *G. paniculata*
 - 5b. Stipules with wings or ribs extending below petiole as a thickened, well-developed wing or flange encircling petiole base.
 - 8a. Corolla tube 8–11 mm long, lobes 3.5–6 mm long, the lobes inflated and cucullate at apex, in bud the lobes forming an urceolate cap; leaves 9–25 × 3–10 cm, with the tertiary venation usually regularly sublineolate and evident abaxially 13. *G. cooperi*
 - 8b. Corolla tube 1.8–9 mm long, lobes 0.8–5 mm long (corolla size unknown in *G. letouzeyi*), the lobes flattened at apex or with an adaxial hook or flange, in bud the lobes forming a smoothly tapered, acute apex; leaves 2.2–33 × 0.8–13.5 cm, with the tertiary venation not evident abaxially or evident and irregularly to regularly areolate.
 - 9a. Leaves 16–33 × 7.5–13.5 cm, consistently large, with petioles rather thickened.
 - 10a. Calyx limb densely puberulent to pilosulose outside; inflorescences 4.5–10 × 4–8 cm 24. *G. gabonensis*
 - 10b. Calyx limb densely puberulent outside; inflorescences 7–23 × 6.5–22 cm . . . 36. *G. letouzeyi*
 - 9b. Leaves 2.2–23 × 0.8–8 cm, at least some of the leaves smaller than in the alternative lead, with petioles generally slender.
 - 11a. Calyx limb truncate or with lobes to 0.4 mm long.
 - 12a. Inflorescences, axes, and pedicels generally ascending; corolla tube 1.8–3.3 mm long, lobes 1.8–2.7 mm long; pedicels 0–2 mm long 5. *G. aurea*
 - 12b. Inflorescences deflexed to pendulous, axes and pedicels spreading to ca. 90 degrees; corolla tube 2.4–4.5 mm long, lobes 2.5–4 mm long; pedicels 1–9 mm long 66. *G. trachystyla* p.p.
 - 11b. Calyx limb lobed, lobes 0.8–4.5 mm long.
 - 13a. Stems pilosulose or hirtellous 8. *G. bieleri* p.p.
 - 13b. Stems glabrous 37. *G. leucothyrsa*

KEY TO *GAERTNERA* SPECIES IN ASIA (INCLUDING SRI LANKA)

- 1a. Leaves ternate, 0.1–0.3 cm wide; Sri Lanka 65. *G. ternifolia*
- 1b. Leaves opposite and/or ternate, 0.4–15 cm wide; widespread.

- 2a. Stipules, young stems, and/or undersides of leaves moderately to densely hirtellous, pilosulose, hispid, velutinous, and/or villous.
- 3a. Stipules with relatively narrow wings encircling base of petiole; peduncles 3–5.5 cm long; inflorescences with branched portion rather lax, corymbiform, 5–12.5 × 5–10 cm.
- 4a. Stipule wings well developed below petioles and extending into ribs along the stipule tube; leaves 2.2–5 cm wide; Borneo 2. *G. alstonii*
- 4b. Stipule wings restricted to area near petiole, the stipule tube generally smooth at least in upper portion; leaves 4–12 cm wide; Singapore and nearby islands 27. *G. grisea*
- 3b. Stipules with relatively broad wings encircling base of petiole; peduncles none or up to 2.5 cm long; inflorescences with branched portion congested-cymose to subcapitate, subglobose, 1.2–3 × 1.2–3 cm.
- 5a. Flowers 4-merous; calyx limb truncate or with lobes up to 1 mm long; corolla tube 7.8–8.5 mm long; Borneo 11. *G. capitulata*
- 5b. Flowers 5-merous; calyx limb lobed, lobes 0.5–4 mm long; corolla tube 4–5 mm long; continental Southeast Asia, Borneo 62. *G. schizocalyx*
- 2b. Stipules, young stems, and undersides of leaves glabrous to puberulent, or stems sparsely hirtellous to pilosulose becoming glabrescent.
- 6a. Inflorescences pendulous on well-developed axillary or supra-axillary reproductive branches with usually reduced leaves.
- 7a. Plants distylous; calyx 1–2 mm wide; fruits 14–17 mm long; Sri Lanka 17. *G. divaricata* p.p.
- 7b. Plants dioecious; calyx 1.5–3.5 mm wide; fruits 7–8 mm long; continental Southeast Asia, Borneo 18. *G. diversifolia*
- 6b. Inflorescences erect to pendulous on principal and/or axillary vegetative branches, or paired on leafless supra-axillary peduncles.
- 8a. Stipules with tubular portion 20–75 mm long, drying chartaceous to leathery, funnellform (i.e., upper part spreading); leaves 20–55 × 7–19 cm, with well-developed cartilaginous margins . . . 47. *G. obesa*
- 8b. Stipules with tubular portion 1–27 mm long, drying membranous to coriaceous, cylindrical (i.e., tubular, not spreading at apex); leaves 1–31 × 0.4–11 cm, with margins not to thinly cartilaginous.
- 9a. Inflorescences regularly paired on axillary or supra-axillary peduncles.
- 10a. Inflorescences lax, with axes dichasial at basal nodes then markedly scorpioid at more distal nodes; secondary leaf veins flat and hardly visible abaxially 17. *G. divaricata*
- 10b. Inflorescences congested to subcapitate, with axes reduced or all dichasial; secondary leaf veins prominulous abaxially 48. *G. oblanceolata*
- 9b. Inflorescences terminal on principal and/or axillary branches, or sometimes pseudoaxillary.
- 11a. Inflorescences few-flowered (i.e., with 1 to 4 flowers), unbranched or branched to 1 order; leaves 1–9.4 × 0.4–4 cm; Sri Lanka.
- 12a. Stipule lobes 1.5–5.5 mm long; flowers sessile or subsessile, with pedicels to 0.6 mm long; corolla tube 12–23 mm long 59. *G. rosea*
- 12b. Stipule lobes 0.1–1 mm long; flowers sessile or with pedicels to 22 mm long; corolla tube 8–12 mm long.
- 13a. Stipule tube 1.2–3 mm long, with narrow wings encircling petioles and extending onto tube; calyx lobes 0.8–2 mm long 25. *G. ×gardneri*
- 13b. Stipule tubes 3–10 mm long, without wings around petioles or on tube; calyx lobes 0.3–0.5 mm long 70. *G. walkeri* p.p.
- 11b. Inflorescences several- to many-flowered (i.e., with 5 to numerous flowers), subcapitate or branched to 1 to 6 orders; leaves 1.5–25 × 0.4–9 cm; widespread.
- 14a. Inflorescences subcapitate to congested-cymose, in shape subglobose to corymbiform, sessile or with peduncle to 3.5 cm long, branched portion 0.5–3.5 × 0.5–3.5 cm; leaves oblanceolate to elliptic or lanceolate, usually narrowly so.
- 15a. Plants drying with orange cast.
- 16a. Calyx truncate or with lobes to 0.3 mm long; Asia 7. *G. belumutensis*
- 16b. Calyx lobes 1–3.5 mm long; Asia 35. *G. kochummenii*
- 15b. Plants drying green or with gray cast.
- 17a. Stipule ribs narrowly winged; inflorescences 0.5–1.5 × 0.5–2 cm 64. *G. sralensis*
- 17b. Stipule ribs broadly winged; inflorescences 1–3.5 × 1–3.5 cm.
- 18a. Leaves 4.3–20 cm long; stipule lobes 7–10 mm long 11. *G. capitulata* p.p.
- 18b. Leaves 15–25 cm long; stipules truncate or with lobes up to 0.3 mm long 26. *G. globigera*
- 14b. Inflorescences rather to very laxly cymose, in shape corymbiform to pyramidal, sessile or usually at least some inflorescences with peduncles 0.9–7.5 cm long, branched portion 0.8–24 × 1.5–22 cm; leaves narrowly to broadly elliptic, lanceolate, ovate, obovate, elliptic-oblong, or oblanceolate.
- 19a. Inflorescences with axes dichasial at lowest nodes then markedly scorpioid at more distal nodes; leaves with secondary veins flat and generally not evident abaxially; Sri Lanka 17. *G. divaricata* p.p.

- 19b. Inflorescences with axes regularly dichasial; leaves with secondary veins evident and usually raised abaxially; widespread.
- 20a. Flowers 4-merous; Peninsular Malaysia, Sarawak, Singapore.
 - 21a. Inflorescences pyramidal, deflexed to pendulous, with branched portion 3–11 × 3–9 cm; stipule lobes ca. 3 mm long 22. *G. fractiflexa*
 - 21b. Inflorescences rounded-corymbiform, erect, with branched portion 0.8–7 × 2.5–6 cm; stipule lobes 0.5–1.5 mm long . . . 69. *G. viminea*
- 20b. Flowers 5-merous; widespread.
 - 22a. Plants distylous, with flowers bisexual; Sri Lanka.
 - 23a. Corolla tubes 4–6 mm long; inflorescences many-flowered, with branched portion 2.5–24 × 1.1–17 cm; leaves 3–20 × 1.5–9 cm 67. *G. vaginans*
 - 23b. Corolla tubes 8.5–12 mm long; inflorescences several- to few-flowered, with branched portion 1.5–5 × 1.5–4.5 cm; leaves 1.5–9.4 × 0.4–4 cm . . . 70. *G. walkeri* p.p.
 - 22b. Plants dioecious, with flowers unisexual (often apparently homostylous in *G. aphanodioica*); continental Southeast Asia, Sumatra, Borneo.
 - 24a. Stipules drying membranous, with tube 7–15 mm long and lobes 1–2.5 mm long; leaves 3–14.5 × 0.8–5 cm; Peninsular Malaysia? 57. *G. ramosa*
 - 24b. Stipules drying chartaceous, with tube 3–25 mm long and lobes 1–7 mm long; leaves 3.5–24 × 0.7–9.5 cm.
 - 25a. Corolla white, with tube 6–8 mm long; stipule lobes 1–4 mm long; growing at 12–60 m above sea level in Borneo 3. *G. aphanodioica*
 - 25b. Corolla pale green to white, with tube 2.5–5 mm long; stipule lobes 1.5–7 mm long; growing at 0–1500 m, Thailand through Peninsular Malaysia and in Sumatra and Borneo 34. *G. junghuhniana*

KEY TO *GAERTNERA* SPECIES IN MADAGASCAR AND THE MASCARENE ISLANDS

- 1a. Stipules persistent as four spatulate to linear segments, these often overlapping due to shortened stem internodes; leaves 0.3–1.5 × 0.3–0.8 cm.
 - 2a. Leaves elliptic; calyx lobes 0.5–2.5 mm long; corolla tube 2.5–3 mm long 23. *G. furcellata*
 - 2b. Leaves cuneiform to spatulate or obovate; calyx lobes 2.4–3 mm long; corolla tube 4–4.5 mm long 45. *G. microphylla*
- 1b. Stipules caducous, deciduous often by fragmentation, or persistent, spathiform to tubular, calyptrate, funnellform, or splitting into 2 segments, overlapping or separated by well-developed stem internodes; leaves 0.3–51 × 0.3–14.5 cm.
 - 3a. Young stems, stipules, and leaves densely hirsute or hispid to pilose, hirtellous, pilosulose, velutinous, or tomentose with spreading, very evident pubescence.
 - 4a. At least the longest calyx lobes 3–14 mm long (do not confuse these with bracts).
 - 5a. Calyx lobes linear to narrowly triangular, pale green to green; secondary leaf veins 6 to 14 pairs; stipules with tube 11–30 mm long 53. *G. phanerophlebia* p.p.
 - 5b. Calyx lobes narrowly lanceolate to elliptic or ovate, white; secondary leaf veins 9 to 12 pairs; stipules with tube 8–21 mm long 54. *G. phyllosepala*
 - 4b. Calyx truncate or with lobes to 2.5 mm long.
 - 6a. Stipules with tube 22–68 mm long; corolla tube 10–13 mm long; plants drying with an orange cast 61. *G. schatzii*
 - 6b. Stipules with tube 7–40 mm long; corolla tube 3–11 mm long; plants not drying as above.
 - 7a. Corolla pale pink to purple; calyx lobes 0.5–2.5 mm long; pubescence drying gray-white 32. *G. ianthina*
 - 7b. Corolla white; calyx truncate or with lobes to 1.5 mm long; pubescence drying reddish brown to brown or gray.
 - 8a. Leaves 1.1–3.1 cm wide, with apex acute to shortly acuminate; corolla tube 6.5–11 mm long 30. *G. hispida*
 - 8b. Leaves 1.9–8.5 cm wide, with apex acute to rounded then sometimes abruptly very shortly cuspidate; corolla tube 3–6 mm long 49b. *G. obovata* var. *sphaerocarpa* p.p.
 - 3b. Young stems, stipules, and leaves glabrous or sparsely to densely puberulent, villosulous, strigillose, strigose, or sericeous with pubescence mostly appressed and not strongly evident.
 - 9a. Flowers solitary or 2 to 4 and fasciculate to shortly cymose; leaves 0.3–7 × 0.3–3.2 cm.
 - 10a. Stem internodes longitudinally ridged, ribbed, or winged; leaves 0.3–3.8 × 0.3–2 cm.
 - 11a. Flowers pedicellate, with pedicels 2.5–19 mm long; corolla tube 4–7.5 mm long.
 - 12a. Calyx lobes 0.4–4 mm long; stems 2-winged with corky bark 1. *G. alata*
 - 12b. Calyx truncate or with lobes to 0.4 mm long; stems with rounded ridges and appressed, non-corky bark 51. *G. pauciflora* p.p.

- 11b. Flowers sessile or subsessile, with pedicels to 1 mm long; corolla tube 2.5–5.5 mm long.
 13a. Stipules caducous; calyx lobes 1.1–4.2 mm long 9. *G. brevipedicellata*
 13b. Stipules persistent or splitting into several segments; calyx lobes 0.5–2.5 mm long. . .
 23. *G. furcellata* p.p.
- 10b. Stems with internodes smooth; leaves 0.5–7 × 0.3–3.2 cm.
 14a. Calyx limb truncate or with lobes to 0.4 mm long; stems glabrous.
 15a. Stipules tubular, with 3 to 4 filiform lobes; inflorescences sessile or with peduncles 9–
 30 mm long 6. *G. bambusifolia*
 15b. Stipules calyptrate, with 2 or 4 triangular to filiform lobes; inflorescences pedunculate,
 with peduncles 2.5–9.1 mm long 51. *G. pauciflora* p.p.
- 14b. Calyx with lobes 0.4–4 mm long; stems glabrous to pilosulose, villosulous, strigose, or sericeous.
 16a. Stipules tubular; leaves 4–6.5 cm long; stems glabrous 16. *G. darcyana* p.p.
 16b. Stipules calyptrate; leaves 0.5–4 cm long; stems pubescent 44. *G. madagascariensis*
- 9b. Flowers several to numerous, 5 or more, in heads or cymes; leaves 3–51 × 1.4–14.6 cm.
 17a. Calyx lobes 1.5–15 mm long, at least some lobes 1.5 mm long or longer.
 18a. Calyx lobes elliptic to narrowly elliptic or elliptic-oblong, markedly narrowed at base, 6–15 mm
 long; flowers mostly or all subtended by 2 white bracteoles 8–16 mm long 55. *G. phyllostachya*
 18b. Calyx lobes triangular to ligulate, spatulate, linear, elliptic-oblong, ovate, or lanceolate,
 broadest or a little narrowed at base, 1.5–8 mm long; bracteoles when present green to pale
 green and 8 mm long or shorter.
 19a. Calyx funnelform to campanulate or tubular, 7–20 mm wide at mouth.
 20a. Calyx lobes ligulate to linear, 6–8 mm long; leaves elliptic-oblong to obovate or
 cuneiform, 3–5.5 × 1.4–4 cm; flowers subsessile 15. *G. cuneifolia*
 20b. Calyx lobes broadly triangular to ligulate, 1.5–5 mm long; leaves elliptic to
 oblanceolate, elliptic-oblong, or obovate, 8–17.5 × 3.5–9 cm; flowers
 pedicellate, with pedicels 5–18 mm long.
 21a. Inflorescence axes and leaves glabrous 10. *G. calycina*
 21b. Inflorescence axes and leaves pubescent
 *Gaertnera* sp. A of Verdcourt (see discussion under *G. calycina*)
- 19b. Calyx limb tubular to campanulate, 1–4.2 mm wide at mouth.
 22a. Flowering stems and peduncles flexuous, with inflorescence pendulous; corollas
 white to pale blue 52. *G. pendula*
 22b. Flowering stems and peduncles not flexuous, with inflorescences ascending;
 corollas white.
 23a. Flowers 3 to 9 in lax fascicles or cymes 0.8–2 × 0.4–2.5 cm 16. *G. darcyana* p.p.
 23b. Flowers 10 or more in lax cymes to subcapitate heads 0.7–19 × 1–20 cm.
 24a. Calyx lobes narrowly spatulate to elliptic-oblong, unequal on an
 individual flower, 5–7 mm long with at least some lobes more than
 5 mm long 31. *G. humblotii*
 24b. Calyx lobes broadly triangular or ovate to linear or narrowly
 spatulate, 1.5–5 mm long.
 25a. Leaves broadly elliptic to obovate or ovate, drying thickly
 coriaceous, 1.5–12 × 0.8–5.5 cm; inflorescences subcapitate
 to congested 60. *G. rotundifolia* p.p.
 25b. Leaves elliptic to elliptic-oblong, oblanceolate, or obovate,
 drying chartaceous to coriaceous, 2.5–24 × 1–14.5 cm;
 inflorescences subcapitate to laxly cymose.
 26a. Stipules calyptrate, caducous or fragmenting quickly,
 with tube 11–55 mm long, drying membranous.
 27a. Inflorescences subcapitate to congested-cymose,
 subsessile or with peduncle to 4.3 cm long, with
 branched portion 0.7–4.5 cm long
 53. *G. phanerophlebia* p.p.
 27b. Inflorescences laxly cymose to somewhat congest-
 ed, pedunculate with peduncle 0.5–4 cm long,
 with branched portion 1.4–7.5 cm long
 58. *G. raphaelii*
- 26b. Stipules tubular, usually regularly persistent at least
 on distalmost nodes or slowly deciduous by fragmen-
 tation, with tube 4–33 mm long, drying chartaceous.
 28a. Stipules 10–33 mm long, cylindrical or usually
 inflated to funnelform 43. *G. macrostipula* p.p.
 28b. Stipules 4–12 mm long, cylindrical.
 29a. Corolla tube ca. 13 mm long
 29. *G. hirtiflora* p.p.
 29b. Corolla tube 16–25 mm long
 68. *G. vaginata*

- 17b. Calyx lobes all less than 1.5 mm long.
- 30a. Stipules tubular, cylindrical to funnellform or inflated, persistent at least on distalmost several nodes, with tubes 10–80 mm long with at least some stipules 25 mm long or longer.
- 31a. Inflorescences pendulous, with branched portion pyramidal 41. *G. lowryi*
- 31b. Inflorescences generally ascending, with branched portion rounded-corymbiform.
- 32a. Stipules entire (i.e., not cleft); corolla white or pink 43. *G. macrostipula*
- 32b. Stipules deeply cleft into two segments; corolla white 46. *G. monstrosa*
- 30b. Stipules calyptrate or tubular, cylindrical and rather closely enclosing the stem or caducous, with tubes 2–50 mm long, if 25 mm long or longer then calyptrate.
- 33a. Plants generally slender; inflorescences ascending or deflexed to pendulous, subsessile or on stiff to flexuous peduncles or stems, sometimes with supra-axillary reproductive branches; corolla tubes 3–8 mm long.
- 34a. Inflorescences subsessile to shortly pedunculate, peduncle to 2.7 cm long, without developed secondary axes or these 1 to 2 pairs and up to 1 cm long; flowers 5-merous 19. *G. drakeana*
- 34b. Inflorescences pedunculate, peduncle 1.5–6 cm long, with 2 to 5 pairs of developed secondary axes, these 0.5–2 cm long; flowers 4-merous.
- 35a. Stipules with tubes 4–10 mm long; leaves usually elliptic-oblong, to elliptic-lanceolate or obovate 12. *G. cardiocarpa*
- 35b. Stipules with tubes 2.3–4.5 mm long; leaves narrowly elliptic to elliptic or oblanceolate 33. *G. inflexa*
- 33b. Plants generally robust; inflorescences ascending on generally straight peduncles or vegetative stems; corolla tubes 3–32 mm long.
- 36a. Stipules tubular and with 4 to 10 setae at apex in addition to 4 linear lobes.
- 37a. Calyx truncate or with lobes to 0.6 mm long; stipules with tubular portion 2–5 mm long; corolla glabrous externally 20. *G. edentata* p.p.
- 37b. Calyx lobed, with lobes 1–2.5 mm long; stipules with tubular portion 5–12 mm long; corolla densely puberulent to velutinous externally 29. *G. hirtiflora* p.p.
- 36b. Stipules calyptrate or tubular, without setae, with lobes none or 1 to 4.
- 38a. Stipules tubular, tubular portion 2–5 mm long. (This measurement arbitrary, species with overlap also listed in next couplet.)
- 39a. Inflorescences with branched portion 2–6 cm wide, with 1 to 2 pairs of developed secondary axes; corolla tube 10–25 mm long 20. *G. edentata* p.p.
- 39b. Inflorescences with branched portion 3–15 cm wide, with 2 to 5 pairs of developed secondary axes; corolla tube 10–14 mm long 56. *G. psychotrioides* p.p.
- 38b. Stipules tubular or calyptrate, with tubular portion more than 5 mm long.
- 40a. Inflorescences subcapitate to congested-cymose, without developed secondary axes or with 1 pair shortly developed and unbranched 60. *G. rotundifolia* p.p.
- 40b. Inflorescences branched with 2 or more pairs of developed, branched secondary axes.
- 41a. Stipules tubular and regularly persistent or sometimes fragmenting when old.
- 42a. Stipules with tubular portion 8–17 mm long; fruit subglobose, 8–11 × 7.5–9 mm 4. *G. arenaria* p.p.
- 42b. Stipules with tubular portion 2–12 mm long; fruit ellipsoid, 7–10 × 6–8 mm 56. *G. psychotrioides* p.p.
- 41b. Stipules tubular or calyptrate, caducous or quickly fragmenting.
- 43a. Corolla with tube 17–32 mm long and lobes 8–12 mm long.
- 44a. Corolla tube 7–9 mm diam. 14. *G. crassiflora*
- 44b. Corolla tube 3–4 mm diam. 39. *G. longifolia*
- 43b. Corolla with tube 3–16 mm long and lobes 2–5.5 mm long.
- 45a. Corolla with tube 10–16 mm long and lobes 3.5–5.5 mm long 4. *G. arenaria* p.p.
- 45b. Corolla with tube 3–10 mm long and lobes 2–4 mm long, if corolla tube 10 mm long then lobes 2–3 mm long.
- 46a. Leaves with base rounded to truncate and secondary veins 8 to 10 pairs; corolla tube 6.5–10 mm long 42. *G. macrobotrys*
- 46b. Leaves with base acute to obtuse and secondary veins 5 to 16 pairs; corolla tube 3–9 mm long.
- 47a. Stipules with tubular portion 11–49 mm long; corolla white; in littoral forests on white sand substrates 28. *G. guillotii*
- 47b. Stipules with tubular portion 8–32 mm long; corolla white to pink or lilac; in various habitats on various substrates 49. *G. obovata* p.p.

1. ***Gaertnera alata*** Bremek. ex Malcomber & A. P. Davis, Monogr. Syst. Bot. Missouri Bot. Gard. 104: 379, fig. 2. 2005. TYPE: Madagascar. Toamasina: Forêt d'Andisibe, bassin de l'Onive, 19°50'S, 47°51'E, Feb. 1925, *H. Perrier de la Bâthie 17098* (holotype, P!).

Shrubs 1–2 m tall; *branchlets* terete, 0.5–2 mm diam., glabrous, usually \pm 2-winged, \pm corky, pale beige to gray or whitish; internodes 0.3–2.7 cm, with 2 or 3 longitudinal ribs. *Leaf* blades 0.6–3.6 \times 0.3–1.8 cm, elliptic to elliptic-oblong or \pm elliptic-obovate, apex acute to shortly abruptly acuminate, base cuneate to rounded, drying chartaceous, glabrous; secondary veins prominulous abaxially, 3 to 5(to 8) pairs; domatia present; petioles 0.9–3 cm. *Stipules* calyptrate, drying membranous, puberulent, caducous or persisting on a few nodes, tube 2–6.6 mm, with ribs 6, narrowly winged, 4 arising below petioles, 1 additional rib on each interpetiolar side, all these extending to apex, apex with 2 clefts, marcescent, lobes 2, 0.7–1.2 mm, deltate. *Inflorescences* terminal on principal and/or axillary branches, 1-flowered or 2- to 3(4)-flowered and subfasciculate, sessile, glabrous or puberulent, ebracteolate; pedicels 2.5–19 mm. *Flowers* 4-merous, presumably heterodistylous. *Long-styled flowers*: unknown. *Short-styled flowers*: calyx cup-shaped to \pm urceolate, 1.5–2.6 mm wide, glabrous except inside with sparse hair-ring, lobes 0.4–4 mm, triangular to narrowly triangular or linear; corolla pale pink to pink, clavate in bud, at anthesis salverform, outside glabrous, tube 5–6 mm, 1.8–2.2 mm diam., glabrous inside, lobes 2.6–6.1 mm, triangular to narrowly triangular, acute; anthers included, filaments inserted just below middle of corolla tube, ca. 0.5 mm; style 2.7–5.4 mm, glabrous, stigma ca. 0.8 mm. *Drupes* unknown.

Distribution and habitat. This species grows in Madagascar, in the provinces of Antananarivo and Toamasina, where it is known from humid evergreen escarpment forest south of Tsinjoarivo and southeast of Ambatolampy, at elevations of 1400–1550 m. Here, it grows on rocks in zones of metamorphic and igneous basement rock.

Phenology. This species has been collected with flowers in the months of January and February.

Discussion. *Gaertnera alata* can be recognized by its combination of few-flowered or solitary-flowered inflorescences, 2-winged rather corky branchlets, pubescent leaf domatia, calyptrate 6-ribbed stipules, relatively long pedicels, and relatively large pink flowers. The measurement for the corolla width given in the protologue, 4.2–12 mm wide, is the width across the corolla lobes at anthesis. This species is

similar in general aspect to some plants of *G. microphylla*, and perhaps closely related to that species. This species is so far known from few collections, and Malcomber and Davis (2005) provisionally considered the conservation status of this species to be Endangered (IUCN, 2001) based primarily on its limited known range. The type was attributed to Antananarivo Province by Malcomber and Davis (2005), but this locality is actually in Toamasina Province as cited here.

Additional specimens examined. MADAGASCAR. **Antananarivo**: 16.2 km SE de Tsinjoarivo, le long de la rivière d'Andrindrimbola, *Messmer & Andriatsiferana NM 690* (G, K), *NM 692* (G, K).

2. ***Gaertnera alstonii*** Malcomber, sp. nov. TYPE: Malaysia. Sabah: Tongod, Kinabatangan, Melian Basin, Gunong Lotung, 830 m, 30 Mar. 1982, *G. Amin SAN 95125* (holotype, SAN!; isotypes, K!, L!, SAR!).

Haec species *Gaertnerae junghuhniana* Miq. similis, sed ab ea foliis oblongis atque stipulis pubescentibus in quoque latere tubi ac sub petiolo alis duabus longitudinalibus prominentibus munitis distinguitur.

Trees, 6–12 m tall; *branches* terete to quadrangular, when young pilosulose with indumentum drying yellow, becoming glabrescent, 2–5 mm diam.; internodes 3.2–5 cm, smooth. *Leaf* blades 6–15 \times 2.2–5 cm, elliptic-oblong or oblanceolate to elliptic, apex shortly cuspidate or acuminate, base cuneate to obtuse, drying chartaceous, adaxially glabrous, abaxially glabrous except pilosulose on principal veins with indumentum drying yellow to brown; secondary veins visible abaxially, 8 to 12 pairs; domatia usually present; petioles 3–10 mm. *Stipules* tubular, pilosulose, drying membranous, deciduous through fragmentation, tube ca. 20 mm, with ribs 4, narrowly winged, arising and well developed below petiole, apex entire or usually with 2 incisions, marcescent, lobes 4, 3–11 mm, deltate to linear. *Inflorescences* terminal on principal and/or axillary branches, cymose, many-flowered, pilosulose; peduncle 3–5 cm; branched portion corymbiform, 5–11 \times 5–17 cm, branched to 4 to 5 orders, lax; bracts 1–6 mm; bracteoles reduced; pedicels 1–3.5 mm. *Flowers* 5-merous, biology unknown, sessile to pedicellate. *Calyx* cup-shaped, 2–3 mm wide, outside pilosulose, inside glabrous, truncate or with lobes to 0.4 mm long, triangular; corolla, anthers, and stigmas unknown. *Drupes* violet-black, subglobose or didymous, 5–7 \times 5–6 mm; pyrenes spherical or hemispherical, rugose, finely fissured, endosperm entire.

Distribution and habitat. *Gaertnera alstonii* grows in Southeast Asia, where it is known from Borneo,

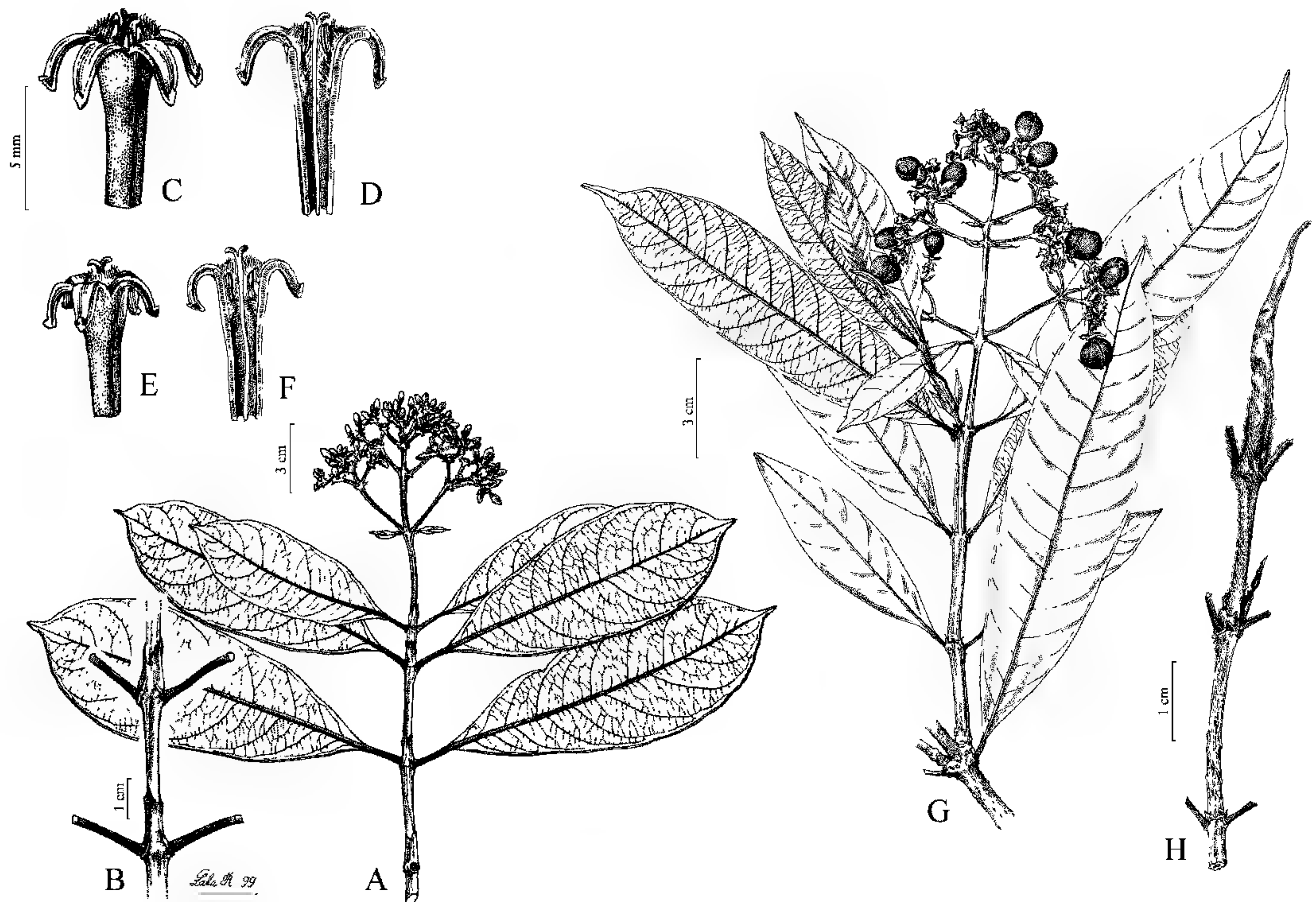

Figure 5. A–F. *Gaertnera aphanodioica* Malcomber. —A. Flowering branch. —B. Portion of stem with petiole bases and stipules. —C. Pistillate flower. —D. Pistillate flower in cross section. —E. Staminate flower. —F. Staminate flower in cross section. G, H. *Gaertnera ianthina* Malcomber. —G. Fruiting branch. —H. Portion of stem with petiole bases, stipules, and stem apex. C–F to same 5-mm scale. A–F based on *Malcomber 2995*; G, H based on *Malcomber 2773*.

specifically in its Kalimantan (Indonesia) and Sabah (Malaysia) sections. Here, it has been found in wet forests, at elevations of 50–2750 m.

Phenology. This species has been collected in fruit in January and March through December.

Discussion. This is a poorly known species represented only by fruiting collections, but it is easily recognized by its often elliptic-oblong leaves, dense short pubescence, and prominent longitudinal wings on the stipule tube that extend downward and encircle the petiole. *Gaertnera alstonii* is named in honor of Arthur Hugh Garfit Alston (1902–1958) who made the first collections of this species. This species belongs to the *G. vaginans* complex; see also the discussion of that group for related species and their distinctions.

Paratypes. INDONESIA. **Kalimantan:** Kwala Kwajan, Permantang, *Alston 13252* (A, L). MALAYSIA. **Sabah:** Kalabakan Forest Reserve, *Sumbing SAN 101357* (SAN); Tawau, Luasong Camp, *Madani SAN 107944* (K, KEP, L, SAN).

3. *Gaertnera aphanodioica* Malcomber, sp. nov.
Gaertnera vaginans subsp. *junghuhniana* f.

hermaphroditica Beusekom, *Blumea* 15(2): 390, fig. 4E. 1967. TYPE: Brunei Darussalam. Belait: Seria, 18 Apr. 1957, *S. Smythies, G. Wood & P. Ashton S 5909* (holotype, L!; isotypes, BRUN!, K!, KEP!, SING!). Figure 5A–F.

Haec species *Gaertnerae junghuhnianae* Miq. similis, sed ab ea tubo corollino 6–8 mm longo atque floribus ut videtur homostylis autem in effectu dioicis distinguitur.

Trees or shrubs, 2–12 m tall; *branches* terete or quadrangular, glabrous, 2–7 mm diam.; internodes 1.5–9 cm, smooth. *Leaf* blades 6–24 × 2–9 cm, elliptic to oblanceolate or ovate, apex shortly acuminate or acute, base cuneate, drying chartaceous, glabrous; secondary veins prominulous abaxially, 3 to 10 pairs; domatia usually present, hirtellous; petioles 5–35 mm. *Stipules* tubular, glabrous, drying chartaceous, caducous or deciduous through fragmentation, tube 10–25 mm, with ribs 4, narrowly winged, arising below petiole and sometimes extending to lobes, apex entire or usually with 2 incisions, marcescent, lobes 4, 1–4 mm, deltate. *Inflorescences* cymose, terminal on axillary branches, many-flowered, puberulent to pilosulose, sessile to pedunculate; peduncle to 6 cm; branched portion corymbiform, 4.5–11 × 4–18 cm,

branched to 3 to 5 orders, lax; bracts 6–20 mm; bracteoles reduced; pedicels to 1 mm. *Flowers* 5-merous, unisexual (but apparently homostylous), sessile to pedicellate. *Pistillate flowers*: calyx cup-shaped, 2–3 mm wide, outside glabrous or puberulent, inside glabrous, truncate or lobes to 0.3 mm, triangular; corolla white, clavate in bud, when open salverform, outside glabrous or puberulent, tube 6–9 mm, 2–4 mm diam., inside villous in upper third, lobes 2–4 mm, ligulate, ovate-oblong, or lanceolate, acute; staminodia included to partly exerted, filaments inserted in upper third of corolla tube, ca. 3 mm; style 7–8.5 mm, glabrous or often pubescent in upper part, stigmas 0.5–1 mm. *Staminate flowers*: similar to pistillate except corolla with tube 2.5–4.5 mm diam., lobes 3.5–4.5 mm; anthers included or shortly exerted, filaments ca. 2 mm; pistillode with style portion 7–8 mm, glabrous, stigmatic portion 1.5–2.5 mm. *Drupe*s violet-black, didymous or subglobose, 5–7 × 5–7 mm; pyrenes spherical or hemispherical, rugose, finely fissured, endosperm entire.

Distribution and habitat. This species grows in Southeast Asia, where it is known from Borneo, specifically its Brunei and western Sabah (Malaysia) sections. It has been found in humid forests at elevations of 12–60 m.

Phenology. This species has been collected with flowers from April through August, and with fruits in August and September.

Discussion. *Gaertnera aphanodioica* as circumscribed here was previously treated by van Beusekom (1967) as a homostylous, bisexual form of *G. vaginans* subsp. *junghuhniana*. However, van Beusekom acknowledged that his form *hermaphroditica* Beusekom was heterogeneous and comprised several recognizable populations that he considered to have evolved in isolation. *Gaertnera aphanodioica* represents one of these populations from Brunei and western Sabah, which includes the type specimen of van Beusekom's form. Pollination studies in Berakas Forest Reserve in Brunei indicate that the plants are not bisexual as van Beusekom suggested, but functionally dioecious with the two flower forms almost indistinguishable (Malcomber, unpublished data). The epithet *aphanodioica* refers to the cryptic dioecy of the species. *Gaertnera aphanodioica* can often be found in the same vicinity as *G. junghuhniana* but differs in the flowers with stigmas or the stigmatic part of the pistillode and stamens or staminodia positioned at the same height within the corolla tube. This species belongs to the *G. vaginans* complex; see also the discussion of that group for related species and their distinctions.

Paratypes. BRUNEI DARUSSALAM. **Belait:** Andulau Forest Reserve, Compartment 5, *Malcomber 2998* (MO), 2999 (MO), 3000 (MO). **Brunei-Muara:** Berakas Forest Reserve, *Hassan S2200* (K, SAR, SING), *Hassan S4928* (BRUN, SAR), *Malcomber 2971* (MO), 2986 (MO), 2987 (MO), 2988 (MO), 2989 (MO), 2990 (MO), 2991 (MO), 2992 (MO), 2993 (MO), 2994 (MO), 2995 (MO), 2996 (MO), 2997 (MO); Universiti Brunei Darussalam campus, *Malcomber 2966* (MO). MALAYSIA. **Sipitang:** Menggalong FR, *Meijer SAN 21809* (K, L, SAN).

4. *Gaertnera arenaria* Baker, J. Linn. Soc., Bot. 20: 209. 1883. *Sykesia arenaria* (Baker) Kuntze, Revis. Gen. Pl. 2: 425. 1891. TYPE: Madagascar. Tranomaro near Tamatave, July 1862, C. J. Meller s.n. (holotype, K!). Figure 6H–N.

Gaertnera spathacea Drake, in Grandid., Hist. Phys. Madagascar 36 (6, Atlas 6): t. 433. 1897 [1898]. *Gaertnera spathacea* Boivin ex Drake, Bull. Soc. Bot. France 45: 353. 1898 [1899], syn. nov. TYPE: Madagascar. Nosy-bé, *Boivin 2074* (holotype, P not located).

Trees or shrubs, 3–10 m tall; *branches* terete to subquadrangular, glabrous, 2–5 mm diam.; internodes 2–5 cm, smooth to shallowly sulcate. *Leaf* blades 5.5–19.5(–26) × 2–8(–11.5) cm, elliptic to oblong or obovate, apex shortly cuspidate, base cuneate or obtuse, drying chartaceous, glabrous; secondary veins prominulous abaxially, 6 to 9(to 11) pairs; domatia absent or present; petioles 2–11 mm. *Stipules* tubular, glabrous, drying chartaceous, persistent or occasionally deciduous after distalmost 1 to 3 nodes, tube 8–17 mm, with ribs 4, narrowly winged, arising below petiole and extending to lobes, apex entire or with 1 or 2 incisions, marcescent, lobes 4, 2.5–5 mm. *Inflorescences* cymose, many-flowered, terminal on principal and/or axillary stems, puberulent to glabrous, sessile or peduncle to 9 cm; branched portion corymbiform to broadly pyramidal, 3.5–18.5 × 5–16 cm, branched to 3 to 5 orders, lax; bracts 1–28(–65) mm; bracteoles triangular to ovate, 1–2 mm; pedicels to 5 mm long. *Flowers* 5-merous, heterodistylous, sessile to pedicellate. *Long-styled flowers*: calyx cup-shaped, 2.5–4 mm wide, outside puberulent at base to glabrous at apex, inside with hair-ring, truncate or lobes 0.2–0.5 mm, triangular; corolla white, rhomboidal in bud, at anthesis salverform, outside glabrous or scabrous, tube 10–16 mm, 1.8–4.5 mm diam., inside villous in upper third, lobes 3.5–5.3 mm, ligulate or oblong, acute; anthers included, filaments inserted in upper third of corolla tube, 1.2–1.5 mm; style 13–15 mm, glabrous, stigma 2–2.5 mm. *Short-styled flowers*: similar to long styled except calyx 2–3.5 mm wide, lobes 0.1–0.3 mm; corolla tube 10–15 mm, 1.5–4 mm diam., lobes 3.5–5.5 mm; anthers shortly exerted, filaments 2–3.5 mm; style 6–6.2 mm, stigma 1.7–1.9 mm. *Drupe*s violet-black, subglobose or globose to



Figure 6. A–G. *Gaertnera junghuhniana* Miq. —A. Flowering branch. —B. Portion of stem with petiole bases, bases of young leaves, stipule, and stem apex. —C. Portion of stem with petiole bases and stipule. —D. Staminate flower. —E. Staminate flower in cross section. —F. Pistillate flower. —G. Pistillate flower in cross section. H–N. *Gaertnera arenaria* Baker. —H. Flowering branch. —I. Fruiting branch. —J. Portion of stem with petiole bases and stipules. —K. Short-styled flower. —L. Short-styled flower in cross section. —M. Long-styled flower. —N. Long-styled flower in cross section. D, E to same 5-mm scale; F, G to same 5-mm scale; K, L to same 1-cm scale; M, N to same 5-mm scale. A–G based on *Malcomber 2028*; H–N based on *Moise 5*.

didymous, 8–11 × 7.5–9 mm; pyrenes spherical to ellipsoid or hemispherical, rugose, finely fissured, endosperm entire.

Distribution and habitat. This species grows in Madagascar, where it is known from the provinces of Antsiranana, Fianarantsoa, Toamasina, and Toliara. Here, it is observed to be widespread in humid forests, at elevations of 0–1400 m, often near oceans.

Phenology. This species has been collected with flowers February through October, and with fruits January through March and September through December.

Discussion. *Gaertnera arenaria* is a member of the *G. vaginans* complex of species; see also the discussion of that group for related species and their distinctions. It is one of the most commonly collected species of *Gaertnera* in Madagascar. *Gaertnera arenaria* differs from other species in this group in its relatively long corolla tube, 10–16 mm long. *Gaertnera arenaria* is also similar to *G. macrobotrys* Baker; see the discussion under this latter species. The holotype collection of *G. spathacea*, *Boivin 2074*,

was not located, but based on its description and several other specimens annotated with this name by Drake, it appears to be synonymous with *G. arenaria*.

Representative specimens examined. MADAGASCAR. **Antsiranana:** Nosy-be, Lokobe, *Birkinshaw 117* (K, MO, TAN); Manongarivo Reserve, Ansatrotro, *Gautier 2807* (G, MO); Bekolosy, *Malcomber 1946* (K, MO, P, TAN); near Ambalafary, *Malcomber 2229* (K, MO, P, TAN); Jardin Botanique, *Malcomber 930* (BR, G, MO, TAN, WAG); Montagne d'Ambre National Park, *Malcomber 1275* (MO, TAN), *1799* (K, MO, P, TAN); Marojejy Nature Reserve, *Schatz 1542* (BR, G, P, TAN, WAG); Sambava, Maroambihy, Anomadiobe, *Silasy RN 9512* (MO, TEF); Ambilobe, *Waterlot 335* (P). **Fianarantsoa:** Mananjary, *Geay 7370* (P). **Toamasina:** Foulpointe, *Decary 16982* (P); Masoala National Park, Andranobe, *Malcomber 2812* (MO), *2815* (MO); Maroantsetra, *Mocquerys 197* (G-DC); Fenerive, Mahambo, *Peltier 2457* (P); Antetezana Forestry Station, *Razafimanantsoa RN 1563* (P). **Toliara:** Tolanaro near airport, *Gereau et al. 3236* (BR, MO, P, TAN, TEF, WAG); Andohahela Nature Reserve, *Malcomber 1152* (K, MO, P, TAN); Eminiminy, Itroky River, *Malcomber 2173* (MO, P, TAN); N of Isaka Ivondry, *Malcomber 2637* (K, MO, P, TAN); NW Manantenina, Ambalavoanio, *Cours 3203* (P, TAN).

5. *Gaertnera aurea* Malcomber, sp. nov. TYPE: Ivory Coast [Côte d'Ivoire]. Left bank of La Mé

River, near bridge to Mérépé, 5°37'N, 3°39'W, 0–50 m, 1962, A. J. M. Leeuwenberg 4154 (holotype, WAG!; isotypes, BR!, K!, L!, MO!, P!).

Haec species *Gaertnerae cooperi* Hutch. & M. B. Moss similis, sed ab ea ramis gracilibus in juventute scabropubescentibus trichomatibus pallide fuscis atque tubo corollino brevior (1.8–3.3 mm longo) apice integro distinguitur.

Trees or shrubs, 2.5–4 m tall; *branches* flattened near apex, otherwise terete, young branches densely puberulent to short-pilosulose with indumentum drying yellow to brown, becoming glabrescent, 1.5–2.5(–6) mm diam.; internodes 0.8–5.5 cm, smooth. *Leaf* blades 6.5–19 × 3–6.5 cm, elliptic to elliptic-oblong or obovate, apex cuspidate to acuminate, base cuneate to obtuse, drying chartaceous, adaxially glabrous, abaxially glabrous or puberulent to pilosulose and sometimes hirtellous on costa and principal veins; secondary veins prominent abaxially, 4 to 7 pairs; domatia present; petioles 4–9 mm. *Stipules* calyptrate, glabrous to densely puberulent or pilosulose, drying chartaceous or membranous, caducous, often leaving a persistent base 1–3 mm, tube 10–54 mm, with ribs 4, low and rounded to narrowly winged, arising beneath petiole and sometimes extending to lobes, apex with a 1-interpetiolar incision, marcescent, lobes 4, 4–5 mm, deltate to linear. *Inflorescences* cymose, many-flowered, terminal on principal and/or axillary branches, densely puberulent to pilosulose; peduncle 1–5 cm; branched portion corymbiform, 1–7 × 1.5–9 cm, branched to 3 to 4 orders, congested to lax; bracts deltate or linear, 1–4 mm; bracteoles reduced; pedicels to 2 mm. *Flowers* 5-merous, heterodistylous, sessile to pedicellate. *Long-styled flowers*: calyx cup-shaped, 1.5–2.5 mm wide, glabrous outside, with hair-ring inside, truncate or lobes to 0.2 mm, triangular; corolla white, clavate in bud, when open salverform, outside puberulent to glabrous, tube 1.8–3.3 mm, 1.7–2.2 mm diam., inside villous in upper third, lobes 1.8–2.3 mm, ligulate or oblong, acute; anthers included, filaments inserted at ca. middle of corolla tube, 0.3–0.6 mm; style 2.8–3.4 mm, glabrous, stigmas 1.8–2.2 mm. *Short-styled flowers*: similar to long styled except calyx lobes up to 0.3 mm; corolla tube 2.3–3.2 mm, 1.7–2.2 mm diam., lobes 2–2.7 mm; anthers fully exerted, filaments inserted in upper third of corolla tube, 0.3–0.7 mm; style 0.8–1.2 mm, stigma 0.9–1.2 mm. *Drupes* violet-black, subglobose to ellipsoid, 5–10 × 5–8 mm; pyrenes ellipsoid or plano-convex to hemi-ellipsoid, rugose, deeply fissured, endosperm ruminated.

Distribution and habitat. This species grows in West Africa, where it is known from Ghana and Côte

d'Ivoire. Here, it has been found in wet forests at elevations of 0–100 m.

Phenology. This species has been collected with flowers throughout the year, and with fruits January through October.

Discussion. *Gaertnera aurea* has been confused with *G. cooperi* but is a more slender plant with a shorter, entire corolla tube, 2.3–3.2 mm long and not fenestrate versus 8–11 mm long and fenestrate in *G. cooperi*. *Gaertnera aurea* and *G. cooperi* share deeply fissured, ruminated pyrenes, an unusual condition. The specific epithet refers to the dense pale beige to brown drying color of the indumentum on the young branches.

Paratypes. GHANA. Bimpong FR, Foso, *Enti SP 599* (BR, MO); Tarkwa Distr., Benso, *Duah 5823* (BR, FHO); Kade Agricultural Station, *Enti SP258* (MO); Benso, Subiri Forest Reserve, *Enti SP346* (MO); Ankasa Forest Reserve, *Enti CG42670* (MO). IVORY COAST [CÔTE D'IVOIRE]. 25 km SW of Guéyo, *Leeuwenberg 3798* (BR, K, MO, P, WAG); 33 km along Abidjan–Adsopé rd., *Leeuwenberg 7992* (K, MO, WAG); Abidjan University garden, *Aké Assi 673* (G, P); Abou-abou forest, betw. Abidjan & Grand Bassam, *Oldeman 240* (K, MO, P, WAG), *F. Hallé 409* (MO, P), *J. de Wilde 3161* (K, WAG), *Leeuwenberg 2366* (BR, FHO, K, L, WAG); betw. Grand Bassam & Azuretti, *C. Geerling 422* (BR, MO, WAG); IRHO, 20 km W of Grand Bassam, *W. de Wilde 348* (BR, K, P, WAG); Yapo forest, 40 km N of Abidjan, *Leeuwenberg 1814* (WAG), *Chatelain 538* (G); Anyama-Aouabo, 25 km N of Abidjan, *Versteegh & Widen Outer 50* (MO, WAG); Assinie, *R. Nozeran s.n.* (P); Abidjan, Banco Arboretum, *Aké Assi 654* (G), *Béjué 2971* (P), *Chatelain 2* (G), *F. Hallé 217* (P), 284 (P), 296 (MO, P), *J. de Wilde 135* (WAG), *F. Hallé 4* (MO); Banco National Park, *W. de Wilde 26* (BR, K, P, WAG), *Poilecot 3447* (G); Gnaou Forest, *Aké Assi 15881* (BR); Malamalesso, Le Bas Comoé, *Chevalier 17542* (P); Pays Adioukrou, Dabou, *Chevalier 17250* (P); Téké Forest, 12 km N of Anyama, *Beentje 568* (WAG); Toumanguié Forest, Aboisso–Grand Bassam rd., *Bamps 2041* (BR).

6. *Gaertnera bambusifolia* Malcomber & A. P. Davis, Monogr. Syst. Bot. Missouri Bot. Gard. 104: 380, fig. 2. 2005. TYPE: Madagascar. Antsiranana: Reserve Naturelle de Marojejy, along trail to the summit of Marojejy Est, NW of Mandena, wet, evergreen forest above second camp, 14°26'S, 49°15'E, 850–1000 m, 11 Feb. 1989, *J. M. Miller & P. P. Lowry II 3978* (holotype, MO-5714849!; isotypes, K!, P!, TAN!).

Trees, to 3 m tall; *branches* terete to flattened, glabrous, 0.5–2 mm diam.; internodes 0.8–4 cm, smooth. *Leaf* blades 2.5–7 × 0.5–1.5 cm, linear-lanceolate to lanceolate, apex acuminate to long acuminate, base cuneate to obtuse, drying chartaceous, glabrous; secondary veins flat to thinly prominulous abaxially, 4 to 6 pairs; domatia absent; petioles 1.3–4.5 mm. *Stipules* tubular, glabrous, drying membranous, caducous, tube 3–5.5 mm, with

ribs none or forming thin ridges under petioles, apex entire, marcescent, lobes 3 or 4, 0.3–2 mm, filiform. *Inflorescences* reduced to a single flower, terminal on principal and/or axillary branches, pendulous, sessile or pedunculate; peduncles 9–30 mm, glabrous; bracteoles reduced. *Flowers* 5-merous, biology unknown. *Calyx* cup-shaped, 1.9–2.5 mm wide, glabrous, truncate or lobes to 0.4 mm, triangular; corolla, anthers, and stigmas unknown. *Immature drupes* subglobose or didymous, 5.5–6 × 5–6 mm.

Distribution and habitat. This species grows in Madagascar, where it is known from the province of Antsiranana. Here, it has been found in humid evergreen forests of the Marojejy National Park and Anjanaharibe-Sud Wildlife Reserve, growing on metamorphic and igneous rocks at elevations of 850–1235 m.

Phenology. This species has been collected with immature fruits in February and March.

Discussion. *Gaertnera bambusifolia* is only known from two immature fruiting collections. The species is named for its distinctive lanceolate leaves and can also be recognized by its relatively short tubular stipules and its inflorescences reduced to a single, often long-pedicellate flower. Malcomber and Davis (2005) considered the conservation status of this species to be Endangered (IUCN, 2001) based primarily on its small known range.

Representative specimens examined. MADAGASCAR. **Antsiranana:** Andapa, Ambodiangezoka, Ambodisatrana, Anjanaharibe-Sud Special Reserve, *Ravelonarivo 680* (K, MO, P, TAN).

7. *Gaertnera belumutensis* Malcomber, sp. nov.

TYPE: Malaysia. Johor: Kluang, Kluang Forest Reserve, Gunung Belumut, summit trail, 2°03'N, 103°33'E, 1000 m, 25 May 1998, *S. T. Malcomber 3024* (holotype, MO!; isotypes, A!, AAU!, BO!, K!, KEP!, L!, QRS!, SAN!, SAR!, SING!).

Haec species *Gaertnerae acuminatae* Benth. similis, sed ab ea planta in sicco aurantiaca atque inflorescentia congesta capituliformi distinguitur.

Trees or shrubs, 1–6 m tall, drying with orange cast; *branches* terete, glabrous, 2–3 mm diam.; internodes 2.5–7 cm, smooth. *Leaf* blades 3.5–14 × 1.2–3.5 cm, elliptic or elliptic-lanceolate, apex shortly cuspidate or acuminate, base attenuate or cuneate, drying chartaceous, glabrous; secondary veins evident abaxially, 5 to 8 pairs; domatia absent or present; petioles 3–14 mm. *Stipules* tubular, glabrous, drying chartaceous, caducous or deciduous through fragmentation, tube 6–13 mm, with ribs 4, narrowly winged, arising below petiole and extending to lobes, apex

entire or with 2 opposite incisions, marcescent, lobes 4, 2–5 mm, deltate to linear. *Inflorescences* congested-cymose, terminal on axillary branches, several- to many-flowered, glabrous, subsessile or peduncle to 3.5 cm; branched portion subglobose or corymbiform, 1.1–3 × 1.5–3 cm, branched to 1 to 3 orders, congested; bracts deltate or trifid, 1–4 mm; bracteoles reduced; pedicels to 2 mm. *Flowers* 5-merous, floral biology unknown, sessile to pedicellate. *Calyx* cup-shaped, 3–5 mm wide, outside glabrous or puberulent, with hair-ring inside, truncate or lobes to 0.3 mm, triangular; corolla, anthers, and stigmas unknown. *Drupes* violet-black, didymous or globose, 6–8 × 7–8 mm; pyrenes spherical or hemispherical, rugose, finely fissured, endosperm entire.

Distribution and habitat. This species grows in southeastern Asia, where it is known from Peninsular Malaysia. Here it has been found in humid forests at elevations of 170–1000 m.

Phenology. This species has been collected with flowers February through May, and with fruits April through September.

Discussion. *Gaertnera belumutensis* is a poorly known species endemic to southern Johor State of Malaysia, with most of the collections from Gunung Belumut. In this region, only *G. belumutensis* and *G. kochummenii* are known to dry with a distinctive orange cast; *G. belumutensis* differs from the latter species in its glabrous stems, leaves, and stipules, and its generally truncate calyx. This species belongs to the *G. vaginans* complex; see also the discussion of that group for related species and their distinctions. The specific epithet refers to the type locality.

Paratypes. MALAYSIA. **Johor:** Endau, South Plateau, *Kiew 2192* (KEP); Gunung Blumut [Gunung Belumut], *Jumali 3004* (SING); Gunung Belumut, summit trail, E of Keluang, *Malcomber 3023* (MO), *Holtum 53* (L), *Shah 2204* (A, L), *Suppiah FRI 17830* (KEP, L, SING), *Whitmore FRI 8726* (K, KEP, L), *Suppiah FRI 17806* (KEP, SING), *FRI 17844* (KEP), *Walker F. S. KEP 33831* (KEP), *Holtum 10687* (K); Gunung Pulai, *Mat 3723* (SING); Kluang, Gunung Gua Riman, *Jumali 3054* (SING); Labis Forest Reserve, *Khairuddin FRI 32848* (KEP).

8. *Gaertnera bieleri* (De Wild.) E. M. A. Petit, Bull. Jard. Bot. État Bruxelles 29: 51. 1959. Basionym: *Psychotria bieleri* De Wild., Ann. Mus. Congo Belge, Bot., sér. 5, 2: 179, t. 64. 1907. TYPE: Belgian Congo [Democratic Republic of the Congo]. Distr. Forestier Central [Equateur-Orientale-Maniema], Haut Lopor, 1904, *R. Bieler s.n.* (holotype, BR!).

Grumilea fissistipula K. Schum. & K. Krause, Bot. Jahrb. Syst. 39: 563. 1907. *Gaertnera fissistipula* (K. Schum. &

K. Krause) E. M. A. Petit, Bull. Jard. Bot. État Bruxelles 29: 39. 1959. TYPE: Cameroon: bei Bipende im Umwald der Ngabilandschaff, Mar. 1900, G. Zenker 2252 ([holotype, B†]; lectotype, designated here, K!; isotypes, BM!, K! [labeled as 2252a]).

Trees or shrubs, 0.5–8 m tall; *branches* terete, when young pilosulose and/or hirtellous with indumentum drying brown or yellow, often becoming glabrescent, 1–4 mm diam.; internodes 0.8–5.5 cm, smooth. *Leaf* blades 2.2–17.5 × 1.1–7.8 cm, elliptic to oblong, oblanceolate, or obovate, apex cuspidate or acuminate, base acute to cuneate, drying chartaceous, adaxially glabrous or pilosulose on principal veins, abaxially glabrous or usually hirtellous to pilosulose or puberulent at least on principal veins with indumentum drying brown; secondary veins prominulous abaxially, 3 to 10 pairs; domatia absent or present; petioles 2–11 mm. *Stipules* tubular, densely hirtellous to pilosulose, drying chartaceous, caducous, tube 2–12 mm, with ribs 4, narrowly winged, arising below petiole and extending to lobes, apex entire or sometimes with 2 opposite incisions, marcescent, lobes 4, 1–10 mm, deltate to filiform, setae none or numerous, to 2 mm. *Inflorescences* cymose, several- to many-flowered, terminal on principal and/or axillary branches, densely pilosulose to hirtellous, sessile or peduncle to 5.4 cm; branched portion subglobose, corymbiform, or narrowly pyramidal, 0.7–6.7 × 1.2–7.4 cm, rather congested, branched to 3 to 4 orders; bracts linear to filiform, 3–21 mm; bracteoles 1–2 mm; pedicels to 3 mm. *Flowers* 5-merous, heterodistylous, sessile to pedicellate. *Long-styled flowers*: calyx cup-shaped, 1–2 mm wide, outside glabrous to puberulent or pilosulose, with hair-ring inside, lobes (0.8–)2–4.5 mm, linear to narrowly triangular or lanceolate; corolla white, clavate in bud, when open infundibuliform or salverform, outside glabrous, tube 4–5 mm, 0.9–2.5 mm diam., inside villous in upper third, lobes 2–3 mm, ligulate or ovate-oblong to lanceolate, acute; anthers included, filaments inserted in upper third of corolla tube, 0.2–0.6 mm; style 4.5–7 mm, glabrous or pubescent, stigmas 0.3–1 mm. *Short-styled flowers*: similar to long styled except calyx lobes 0.9–3 mm; corolla tube 3–4.5 mm, 0.8–3 mm diam., lobes 1.4–3.5 mm; anthers fully exerted, filaments 2.2–3.6 mm; style 2–3.8 mm, glabrous, stigmas 1–1.4 mm. *Drupe*s violet-black, globose or subglobose, 5–12 × 5–12 mm; pyrenes spherical or hemispherical, rugose, finely fissured, endosperm entire.

Distribution and habitat. This species grows in Central Africa, and also in West Africa east of the Dahomey Gap. It has been found in Cameroon, the Democratic Republic of the Congo, and Nigeria, in humid forests at elevations of 50–1270 m.

Phenology. This species has been collected with flowers throughout the year, and with fruits February through July.

Discussion. *Gaertnera bieleri* is a morphologically variable species, particularly in inflorescence shape, which may be subglobose, corymbiform, or pyramidal, although the inflorescence axes are usually relatively short and congested in all of these. This species is recognizable by its puberulent to hirtellous indumentum, well-developed linear-filiform calyx lobes, and stipule tubes with longitudinal ridges and four lobes plus sometimes numerous setae at the top. *Gaertnera bieleri* is similar to *G. longivaginalis* var. *bracteata* (E. M. A. Petit) Malcomber; see comments under that section of the paper as well.

The type of *Gaertnera fissistipula* was destroyed with the general Rubiaceae collection in the Berlin herbarium; the isotype specimen at K is selected here as lectotype because a digital image is available on the Aluka web site: <<http://www.aluka.org/page/content/plants.jsp>>.

Representative specimens examined. CAMEROON. 55 km SE of Eséka, S of Nyong River, 5 km W of Songhong, *Leeuwenberg 5074* (K, MO, P, WAG); Bipende, *Zenker 4419* (BM, BR, K, L, P); Korup National Park, *Thomas 4398* (K, MO, WAG), *D. Thomas 6856* (MO). DEMOCRATIC REPUBLIC OF THE CONGO. 60 km N of Kisangani, Bengamiea, *Lisowski 18904* (BR, K); Eala, *Lebrun 331* (BR, FHO, G, P), *Pynaert 1788* (BR); Kiou, Shabunda, Bulumba, *J. Léonard 3743* (BR, FHO, G, K); Leopoldville, Inongo, betw. Selenge & Lukolela, *Goossens 5017* (K). GABON. **Woleu Ntem**: 20 km E of Mitzié, *Jeffrey 231* (K, P). NIGERIA. Stubbs Creek Forest Reserve, 30 km E of Eket, *Van Meer 1185* (WAG).

9. *Gaertnera brevipedicellata* Malcomber & A. P. Davis, Monogr. Syst. Bot. Missouri Bot. Gard. 104: 382, fig. 3. 2005. TYPE: Madagascar. Fianarantsoa: Ranomafana National Park, Talatakely, 21°16'S, 47°25'E, 800–900 m, 5 Nov. 1997, S. Malcomber, A. Davis, D. Gower, J. Andriantiana & A. Katozafy 2877 (holotype, MO!; isotypes, BR!, G!, K!, P!, PRE!, TEF!, WAG!).

Shrubs, 2–6 m tall, sometimes clambering; *branches* terete, glabrous, 0.5–3 mm diam., with bark corky, pale gray; internodes 0.4–4.5 cm, with 2 longitudinal ribs or wings. *Leaf* blades 0.8–3.8 × 0.4–2 cm, elliptic or ovate to elliptic-oblong, apex shortly acuminate, base obtuse to acute, drying chartaceous, glabrous; secondary veins thinly prominulous abaxially, 3 to 5 pairs; domatia absent; petioles 1.2–2.8 mm. *Stipules* calyptrate, glabrous, drying membranous, caducous, tube 1.6–7.5 mm, with ribs 4, narrowly winged, arising beneath petiole extending to lobes, additionally 1 rib on each side extending along middle of interpetiolar side, with wings under petioles

becoming indurated and somewhat enlarged with age, apex with 1 or 2 incisions, marcescent, lobes 4, 0.4–1 mm, linear. *Inflorescences* reduced to a single flower, terminal on axillary branches; bracteoles reduced. *Flowers* 5-merous, heterodistylous, subsessile. *Long-styled flowers*: calyx cup-shaped, 1.5–2 mm wide, glabrous, lobes 1.1–4.2 mm, narrowly triangular to linear; corolla pink, clavate in bud, when open salverform, outside glabrous, tube 3–3.5 mm, 1.4–2.5 mm diam., inside villous at ca. middle, lobes 3.5–4.8 mm, triangular or ligulate, acute; anthers included, filaments inserted at ca. middle of corolla tube, ca. 0.2 mm; style 4.5–5.5 mm, glabrous, stigma 1–1.2 mm. *Short-styled flowers*: similar to long styled except calyx lobes 1–4.5 mm; corolla tube 4–5.5 mm, 1–2.5 mm diam., lobes 4–5 mm; anthers shortly exerted, filaments 2.5–3.5 mm; style 1.5–2 mm, stigma 1.5–1.6 mm. *Drupes* violet-black, subglobose or didymous, 4.5–5.5 × 4.5–7 mm; pyrenes spherical or hemispherical, rugose, finely fissured, endosperm entire.

Distribution and habitat. This species grows in Madagascar, where it has been found in the province of Fianarantsoa in humid evergreen forests in the Ranomafana National Park. Here, it grows on metamorphic and igneous rocks at elevations of 800–1000 m.

Phenology. This species has been collected with flowers in November and once with fruits, but the month of that collection was not noted.

Discussion. *Gaertnera brevipedicellata* is similar to *G. madagascariensis* in the inflorescence reduced to a single flower, but differs from that species in lack of indumentum, internodes and stipules with prominent longitudinal ridges or wings, and pink subsessile flowers. The well-developed internode ridges or wings are distinctive; these do not extend onto the stipule sheath. Malcomber and Davis (2005) considered the conservation status of this species to be Endangered (IUCN, 2001) primarily due to its limited known range.

Representative specimens examined. MADAGASCAR. **Fianarantsoa:** Ranomafana National Park, Talatakely, *Kotozafy 1073* (MO, TEF), *Malcomber 2876* (MO, TEF); Ranomafana National Park, Vatoharanana, *Malcomber 2867* (MO, TEF).

10. *Gaertnera calycina* Bojer, Hortus Maurit. 217. 1837. *Sykesia calycina* (Bojer) Kuntze, Revis. Gen. Pl. 2: 425. 1891. TYPE: Mauritius. Grand Bassin and Chamarel, *W. Bojer s.n.* (holotype, P not located; isotypes, BM!, MAU!).

Gaertnera calycina var. *variegata* Bojer, Hortus Maurit. 217. 1837. TYPE: Mauritius. Trois Ilots, *Bojer s.n.* (holotype, P not located).

Gaertnera aetheonoma Steud., Nomencl. Bot. [Steudel], ed. 2, 1: 651. 1840, nom. nud. *Gaertnera vaginata* Sieber ex A. DC., Prodr. (DC.) 9: 35 (1845), nom. nud., pro syn. TYPE: Mauritius. s. loc., *Sieber s.n.* (holotype, P not located).

Gaertnera sieberi C. Presl, Abh. Königl. Böhm. Ges. Wiss. 5, Bd. 3: 507. 1845, nom. nud. TYPE: Mauritius. s. loc., *Sieber 55* (holotype, PR? not located).

Trees or shrubs, 0.9–1.2 m tall; *branches* terete to subquadrate, glabrous, 4–7 mm diam.; internodes 0.5–3.5 cm, smooth. *Leaf* blades 8–17.5 × 3.5–9 cm, elliptic to oblanceolate or elliptic-oblong, apex obtuse then shortly cuspidate or rounded, base acute or cuneate, drying chartaceous, glabrous; secondary veins prominulous abaxially, 10 to 13 pairs; domatia absent or present; petioles 17–30(–40) mm. *Stipules* incompletely known, caducous or fragmenting leaving truncate basal portion 2–5 mm, glabrous, marcescent. *Inflorescences* cymose, many-flowered, terminal on principal and/or axillary branches, glabrous; peduncle 3–4 cm long; branched portion corymbiform, 5–12 × 7–24 cm, branched to 2 to 3 orders, lax; bracts ligulate to ovate, deltate, or trifid, 12–30 mm, glabrous; bracteoles 3–8 mm; pedicels 5–18 mm, sometimes articulated above middle. *Flowers* 5-merous, presumably heterodistylous. *Long-styled flowers*: calyx campanulate, 9–20 mm wide, glabrous, lobes 2–5 mm, broadly triangular to rounded; corolla apparently white, clavate in bud, when open salverform, outside glabrous, tube 15–20 mm, 3.5–4 mm diam., inside villous in upper third, lobes 10–14 mm, ligulate to oblong, acute; anthers included, filaments inserted in upper third of corolla tube, ca. 1.5 mm; style 20–25 mm, glabrous, stigma 2.5–3 mm. *Short-styled flowers*: unknown. *Drupes* black (Bojer, 1837) or violet-black, ellipsoid to fusiform, 15–20 × 5–8 mm; pyrenes plano-convex or ellipsoid, rugose, finely fissured, endosperm entire.

Distribution and habitat. *Gaertnera calycina* grows in Mauritius and perhaps also in Madagascar. The localities, habitat, and elevation have not been recorded.

Phenology. This species was collected with flowers in March and has been collected in fruit, but the months of those collections were not noted.

Discussion. This unusual, probably showy and certainly striking species is notable for its relatively large calyx and is incompletely known and probably extinct (Walter & Gillett, 1998). The report of its distribution in Madagascar is based on one collection that is probably labeled erroneously. The most recent collection of this species was made by Bouton in the early 20th century (exact date unknown).

A similar but apparently distinct taxon, "*Gaertnera* sp. A" of Verdcourt (1983, 1989), was collected on Mauritius by Edgerley (as MAU 13414) in 1969. These plants differ from *G. calycina* in the pubescent inflorescence axes, smaller calyx, and larger pubescent leaves. Verdcourt (1989) noted that this collection is intermediate morphologically between *G. calycina* and a pubescent-leaved form of *G. longifolia* and could represent a hybrid between these two species, or could be equivalent to *G. calycina* var. *variegata*. Numerous researchers including S.T.M. have revisited Bassin Blanc attempting to re-collect both *G. calycina* and "*G. sp. A*" without success. Rare or extinct *Gaertnera* species have recently been rediscovered in Mauritius (e.g., *G. longifolia* var. *pubescens*; Anonymous, 1997), even in areas now dominated by introduced species, so "*G. sp. A*" and *G. calycina* might be rediscovered with continued exploration.

One variety of *Gaertnera calycina* has been described, based on the calyx white rather than green. Because this species has not been seen recently, the status of this variety is difficult to evaluate, but some other *Gaertnera* species show similar within-population variation in calyx color (e.g., *G. phyllostachya*) that does not seem taxonomically informative; consequently, variety *variegata* is not recognized here.

In the protologue for *Gaertnera calycina*, Bojer suggested tentatively that the name *Chassalia divaricata* DC. might also apply to this species, but he did not clearly accept the synonymy; thus, his name is treated here as validly published. *Chassalia divaricata* was more recently treated as a synonym of *C. lanceolata* (Poir.) A. Chev. (Verdcourt, 1989). As discussed above, de Candolle (1845) placed *G. calycina* into its own group, section *Aetheonoma*, based on several characters including an irregular arrangement of the anthers, with three alternipetalous and the other two opposite the corolla lobes. This condition has not been confirmed (cf. Verdcourt, 1989; S.T.M., pers. obs.) and may be an artifact of the preparation of some specimens. Steudel's name *G. aetheonoma* was apparently based on a specimen of Sieber's that was previously identified as *G. vaginata*.

Representative specimens examined. MADAGASCAR. s. loc., L. A. Chapelier s.n. (P). MAURITIUS. Grand Bassin Nouvelle Decouverte, L. S. Bouton s.n. (K); s. loc., Sieber 52 (E, G, L, MO, P, W), 188 (E, L, P).

11. *Gaertnera capitulata* Malcomber, sp. nov.

TYPE: Malaysia. Sarawak: Sri Aman, Selepong Barangan, 15 Aug. 1991, Y. P. C. Runi S 59673 (holotype, SAN!; isotypes, K!, KEP!, L!, MO!).

Haec species *Gaertnerae junghuhnianae* Miq. similis, sed ab ea stipulis in quoque latere tubi ac sub petiolo alis duabus

longitudinalibus prominentibus munitis atque inflorescentia congesta capituliformi distinguitur.

Shrubs, up to 1.5 m tall; *branches* terete, when young hirtellous to puberulent with indumentum drying reddish yellow, white, or brown, becoming glabrescent, 1–4 mm diam.; internodes 2–6 cm, smooth. *Leaf* blades 4.3–20 × 1.3–5.8 cm, elliptic to oblanceolate, apex acute to acuminate, base acute to cuneate, drying chartaceous, adaxially glabrous, abaxially hirtellous to villous or tomentulose with indumentum drying brown or reddened; secondary veins prominulous abaxially, 4 to 10 pairs; domatia absent; petioles 3–20 mm. *Stipules* tubular, hirtellous to villous, drying chartaceous, persistent on distalmost nodes or deciduous leaving a truncate persistent base 1–4 mm, tube 6.5–13 mm, with ribs 4, broadly winged, arising below petiole and extending to lobes, apex entire or with 2 incisions, marcescent, lobes 4, 7–10 mm, deltate to linear. *Inflorescences* congested-cymose to subcapitate, many-flowered, terminal on principal and/or axillary branches, puberulent to hirtellous or villous, sessile or peduncle to 1.4 cm; branched portion subglobose, 1.2–3 × 1.2–3 cm, branched to 1 to 2 orders; bracts deltate, 1–10 mm; bracteoles reduced; pedicels to 1.5 mm. *Flowers* 4-merous, unisexual, sessile to pedicellate. *Pistillate flowers*: unknown. *Staminate flowers*: calyx cup-shaped, 2.5–3 mm wide, outside pilosulose or tomentulose, glabrous inside, truncate or lobes to 1 mm, triangular; corolla white, clavate in bud, when open salverform, outside puberulent, tube 7.5–8.5 mm, 0.7–2.5 mm diam., inside villous in upper third, lobes 2.5–3.5 mm, ligulate, apex acute; anthers shortly exerted, filaments inserted in upper third of corolla tube, ca. 0.3 mm; pistillode reduced. *Drupe*s unknown.

Distribution and habitat. This species grows in Southeast Asia, where it is known from Borneo, in both its Sarawak (Malaysia) and Kalimantan (Indonesia) sections. Here, it has been found in humid forests at elevations of 45–700 m.

Phenology. This species has been collected with flowers April through November.

Discussion. *Gaertnera capitulata* differs from most other Southeast Asian *Gaertnera* species by its prominent longitudinal wings arising beneath the petioles and extending along the stipule tube, generally elliptic leaves, and congested, subglobose inflorescences. It is similar to *G. schizocalyx*; see additional comments under that species. Most collections are densely pubescent but *Lee S 45386* is puberulent. This species belongs to the *G. vaginans* complex; see also the discussion of that group for related species and

their distinctions. The specific epithet refers to the often subcapitate inflorescences.

Paratypes. INDONESIA. **Kalimantan:** Upper Katingan River, 50–100 km WNW of Tumbang Samba, *Mogea 3457* (K, KEP, L). MALAYSIA. **Sarawak:** Belaga, Linau, Sungei Iban, *Lee S 45386* (K, KEP, SAN, SAR); Bukit Mersing, *Sibat ak Luang S 21999* (K, SAN, SING); Sri Aman Distr., Selepong Barangan, *Malcomber 3037* (MO), *Rena George S 58327* (K, L, SAR).

12. *Gaertnera cardiocarpa* Boivin ex Baill., *Adansonia* 12: 238. 1879. TYPE: Madagascar. Toamasina: Sainte Marie, Tanambo, Apr. 1851, *L.-H. Boivin s.n.* (holotype, P!; isotype, G!).

Trees, 3–6 m tall, or sometimes climbing; *branches* flattened to terete, glabrous, 0.5–2.5 mm diam.; internodes 1.2–6 cm, smooth. *Leaf* blades 4.5–8 (–13.5) × 1.4–4(–6) cm, elliptic-lanceolate, elliptic-oblong, or elliptic to obovate, apex cuspidate or acuminate, base acute to cuneate, drying coriaceous or chartaceous, glabrous; secondary veins prominent abaxially, (5 to) 7 to 11 pairs; domatia absent or present; petioles (2–) 4–11 mm. *Stipules* tubular, glabrous, drying chartaceous, caducous or rarely persistent on distalmost 1 or 2 nodes, tube 4–10 mm, with ribs 4, narrowly winged, arising below petiole and extending to lobes, apex entire or with 1 incision, marcescent, lobes 4, 0.3–1.5 mm, deltate to linear. *Inflorescences* cymose, many-flowered, terminal on principal and/or axillary branches, glabrous; peduncle 2.5–6 cm; branched portion narrowly pyramidal, 1.8–11.5 × 1.5–7 cm, pendulous, branched to 2 to 3 orders, lax; bracts deltate, 1.5–7 mm; bracteoles triangular to lanceolate, 0.5–1.5 mm; pedicels absent or to 3 mm. *Flowers* 4-merous, heterodistylous. *Long-styled flowers:* calyx cup-shaped, 1.5–3 mm wide, glabrous, truncate or lobes to 0.3 mm, triangular; corolla white, clavate in bud, when open salverform, outside glabrous, tube 5–6 mm, 1.3–2.5 mm diam., inside villous at ca. middle, lobes 3.5–5 mm, triangular to ligulate, acute; anthers included, filaments inserted at ca. middle of corolla tube, ca. 0.4 mm long; style 5.5–7 mm, glabrous, stigma 1.5–2 mm. *Short-styled flowers:* similar to long styled except calyx 1.8–3 mm wide, lobes to 0.2 mm; corolla tube 1.2–2.5 mm diam.; filaments 0.9–1.5 mm; style 1.3–2 long, stigmas 1–1.5 mm. *Drupes* violet-black, globose to subglobose or didymous, 5.5–6 × 7–7.5 mm; pyrenes spherical or hemispherical, rugose, finely fissured, endosperm entire.

Distribution and habitat. This species grows in Madagascar, where it is known from the province of Toamasina. Here, it has been found in the Île Sainte Marie, Mananara-Nord National Park, and the

Masoala Peninsula, growing in humid forests at elevations of 0–300 m.

Phenology. This species has been collected with flowers May through November, and with fruits April through October.

Discussion. *Gaertnera cardiocarpa* can be recognized by its chartaceous to coriaceous leaves, narrowly pyramidal inflorescences, and 4-merous distylous flowers. It is generally similar to *G. inflexa*, but differs in its inflorescences usually borne terminally on axillary branches and its reduced stipule lobes. *Gaertnera cardiocarpa* often dries blue-gray when the collections are not preserved in alcohol prior to drying. A climbing habit is reported in the notes of *Dumetz 914*, but other specimens are reported as trees.

Representative specimens examined. MADAGASCAR. **Toamasina:** Mananara-Nord, Ivontaka-Sud, *Dumetz 914* (MO); Masoala Peninsula, *Schatz 2705* (MO, P, TAN), *Lowry et al. 4471* (MO, P), *Lowry 4486A* (MO, P), *4127* (MO, P), *Malcomber 2803* (MO, TEF), *Malcomber 2820* (MO, TEF).

13. *Gaertnera cooperi* Hutch. & M. B. Moss, *Fl. W. Trop. Afr.* 2: 21. 1931. TYPE: Liberia. Dukwia River, *G. P. Cooper 287* (holotype, K!; isotype, A!).

Trees or shrubs, 4–8 m tall; *branches* flattened to quadrangular or terete, when young puberulent to pilosulose with indumentum drying reddish to brown, becoming glabrescent to pilosulose with indumentum drying pale brown, 1.5–8 mm diam.; internodes 1.5–8 cm, smooth. *Leaf* blades 9–25 × 3–10 cm, elliptic to oblong or ovate, apex shortly cuspidate to acute, base cuneate to obtuse, drying coriaceous to stiffly chartaceous, adaxially glabrous, abaxially glabrous or puberulent on principal veins to throughout with indumentum drying reddish to brown; secondary veins prominent abaxially, 5 to 10 pairs; domatia absent; petioles 8–22 mm. *Stipules* calyprate, densely puberulent to pilosulose, drying membranous, soon deciduous, tube 9–22.5 mm, with ribs 4, narrowly winged, encircling petiole base and extending to lobes, after falling leaving a persistent tubular base 1.5–2 mm high, apex with 1 or 2 incisions, marcescent, lobes 4, 0.5–3 mm, deltate. *Inflorescences* cymose, many-flowered, terminal on principal and/or axillary branches, densely puberulent to pilosulose or strigillose; peduncle 0.5–9 cm long; branched portion corymbiform, 2–8 × 1.5–16 cm, branched to 3 to 5 orders, rather congested; bracts deltate or linear to lanceolate, 1–9(–40) mm; bracteoles reduced; pedicels absent or to 2.8 mm. *Flowers* 5-merous, heterodistylous. *Long-styled flowers:* calyx cup-shaped, 3.5–4.5 mm wide, glabrous to densely puberulent outside,

glabrous inside, lobes 0.3–4 mm, triangular to narrowly triangular; corolla white, clavate-urceolate in bud, when open salverform, outside glabrous to densely puberulent, tube 8–11 mm, 2–3 mm diam., fenestrate in upper part, inside villous in upper third, lobes 3.5–6 mm, spatulate to oblanceolate, apex inflated and cucullate; anthers shortly exerted, filaments inserted in upper third of corolla tube, 2–3.5 mm; style 12–15 mm, glabrous, stigma 1–1.5 mm. *Short-styled flowers*: similar to long styled except calyx 4.5–5 mm wide, lobes 0.1–0.5 mm; corolla 8–10.5 mm, 1.5–3 mm diam., lobes 3.5–6 mm; anthers well exerted, filaments 3–4 mm; style 2.5–3 mm, stigma 1.8–2.5 mm. *Drupes* violet-black, globose to subglobose or didymous, 5–10 × 5–8 mm; pyrenes spherical to ellipsoid or hemispherical to hemi-ellipsoid, rugose, deeply fissured, endosperm ruminate.

Distribution and habitat. This species grows in West Africa, where it has been found in Ghana, Côte d'Ivoire, and Liberia. Here, it has been found growing in humid forests at elevations of 80–90 m.

Phenology. This species has been collected with flowers January, February, and May through December, and with fruits January through May and October through December.

Discussion. *Gaertnera cooperi* is similar to *G. aurea*, also of Ghana and Côte d'Ivoire; *G. cooperi* differs in its leaves drying coriaceous to stiffly chartaceous, its larger flowers with corolla tubes 8–11 mm long, and its corolla that is fenestrate in the upper part of the tube. This last character is unique in *Gaertnera*. On dried specimens of this species, the tertiary leaf venation is usually regularly sublineolate and well marked, in contrast to this venation being not evident or irregularly areolate in most *Gaertnera* species.

Gaertnera cooperi was first published with an English description and then was republished with a Latin description by the same authors in Kew Bull. 1937: 62, 1937, which is sometimes cited as its place of publication. However, a Latin description is not required by the *International Code of Botanical Nomenclature* (ICBN; McNeil et al., 2006) for valid publication of a name before 1 January 1935, so the first publication was adequate. As noted by Petit (1959a), the paratype specimens *Chevalier 12420*, *Chevalier 12664*, and *Chevalier 12936* do not belong to the same species as holotype; these specimens are included here in *G. longivaginalis* var. *bracteata*.

Representative specimens examined. GHANA. Ateiku, *Vigne 1948* (K). IVORY COAST [CÔTE D'IVOIRE]. Tai National Park, beside Gala trail, *Gautier-Beguin 1032* (G),

Aké Assi 17797 (G, MO). LIBERIA. Grand Bassa Co., Barclayville, *Baldwin 11121* (K, MO); Bodji Town, *Adam 16307* (K, MO); Monrovia, 16 mi. N of University Forest, *Jansen 1650* (K, MO, WAG); near Firestone Plantations, Dukwai River, *Cooper 465* (BM, FHO, GH, K).

14. *Gaertnera crassiflora* Bojer, Hortus Maurit. 216. 1837. *Gaertnera crassifolia*, orth. var. *Sykesia crassiflora* (Bojer) Kuntze, Revis. Gen. Pl. 2: 425. 1891. TYPE: Mauritius. Trois Ilots et autour de Grand Bassin, *W. Bojer s.n.* (holotype, P not located; isotype, G-DC!).

Trees, height not noted; branches terete, glabrous, 3–5 mm diam.; internodes 1.5–2 cm, smooth. *Leaf* blades 12–19 × 5.8–7.5 cm, oblong to elliptic, apex rounded then abruptly contracted into a short tip, base cuneate, drying coriaceous, glabrous; secondary veins visible abaxially, ca. 7 pairs; domatia absent; petioles 10–15 mm. *Stipules* incompletely known, calyptrate, glabrous, caducous, tube length unknown, with ribs 4, narrowly winged, arising below petiole and extending to lobes, apex marcescent, lobes unknown. *Inflorescences* cymose, few-flowered, terminal on principal stems, glabrous; peduncle 1.5–2.5 cm; branched portion subglobose or corymbiform, 2.8–8.5 × 2–7 cm, branched to 1 to 2 orders, rather congested; bracts ligulate to ovate or trifid, 1–6 mm; bracteoles 1–5 mm. *Flowers* 5-merous, heterodistylous, subsessile. *Long-styled flowers*: calyx cup-shaped, 6–7 mm wide, outside glabrous, with hair-ring inside, truncate or lobes to 0.4 mm, triangular; corolla color unknown, clavate in bud, when open infundibuliform to salverform, glabrous outside, tube 28–32 mm, 7–9 mm diam., inside glabrous, lobes 10–12 mm, ligulate or elliptic-oblong, acute to obtuse; anthers included, filaments inserted in upper third of corolla tube, 0.2–0.3 mm; style 20–21 mm, glabrous, stigma 0.6–1.3 mm. *Short-styled flowers*: similar to long styled except corolla tube 17–19 mm, 3–5 mm diam.; anthers shortly exerted, filaments ca. 1.5 mm; style 15–16 mm, stigma 6.5–7 mm. *Drupes* unknown, said to be ellipsoid to fusiform or pyramidal and white at maturity (Bojer, 1837).

Distribution and habitat. This species grows in Mauritius and has been reported also to grow in Madagascar, but this report seems doubtful, as discussed below. The habitat and elevational range have not been recorded.

Phenology. The collection dates for the specimens of this species have not been noted.

Discussion. This species is poorly known and probably extinct (Walter & Gillett, 1998). *Gaertnera crassiflora* can be recognized by its deciduous calyptrate stipules leaving persistent bases with

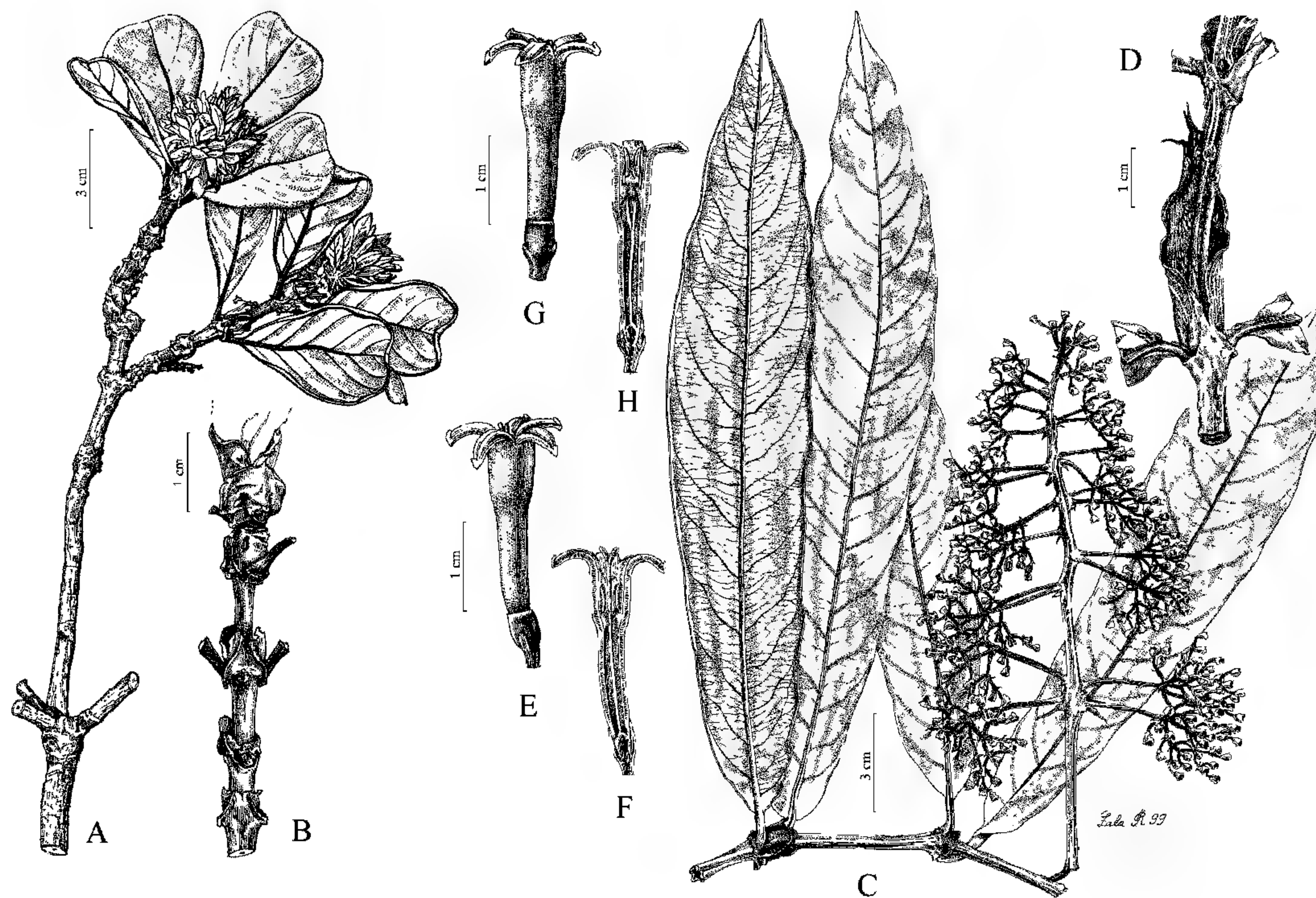

Figure 7. A, B. *Gaertnera cuneifolia* Bojer. —A. Flowering branch. —B. Portion of stem with petiole bases, stipules, and stem apex (young leaves not fully detailed). C–H. *Gaertnera lowryi* Malcomber. —C. Flowering branch (peduncle broken). —D. Portion of stem with leaf bases and stipules. —E. Long-styled flower. —F. Long-styled flower in cross section. —G. Short-styled flower. —H. Short-styled flower in cross section. E, F to same 1-cm scale; G, H to same 1-cm scale. A, B based on Malcomber 2940; C–H based on Malcomber 2888.

well-developed longitudinal wings and its subglobose to congested-corymbiform inflorescences. The collection locality of one specimen of this species, *Goudot s.n.* (G), is not from Mauritius and is given as near Tananarive (— Antananarivo), Madagascar. This species has not been found again in this region, and the distributional record seems most likely a labeling error.

Additional specimens examined. MADAGASCAR. **Antananarivo:** Near Tananarive [i.e., Antananarivo], *J. P. Goudot s.n.* (G). MAURITIUS. s. loc., *Bélanger 101* (P); received 1840, *J. P. Goudot s.n.* (G); received Nov. 1875, *Herb. Horne s.n.* (K); *Herb. Roxburgh s.n.* (BM).

15. *Gaertnera cuneifolia* Bojer, Hortus Maurit. 216. 1837. *Sykesia cuneifolia* (Bojer) Kuntze, Revis. Gen. Pl. 2: 425. 1891. TYPE: Mauritius. Forests of Flacq, at Nouvelle Decouverte and on the peak in the middle of the island, *W. Bojer s.n.* (holotype, P not located; isotype, G-DC!). Figure 7A, B.

Trees or shrubs, 1–2 m tall; *branches* terete to flattened, glabrous, 3–5 mm diam.; internodes 0.5–1 cm, smooth. *Leaf* blades 3–5.5 × 1.4–4 cm, elliptic-oblong or obovate to cuneiform, apex rounded

to truncate and sometimes abruptly shortly cuspidate, base acute to obtuse, margins often thinly revolute, drying stiffly coriaceous, glabrous; secondary veins prominulous abaxially, 5 to 7 pairs; domatia usually present; petioles 2–5 mm. *Stipules* calyptrate, glabrous or pilosulose at least in upper part, drying membranous, caducous or deciduous through fragmentation, tube 14–20 mm, with ribs 4, arising below petioles, not extending onto tube or uniting in basal part of interpetiolar side of tube, apex with 1 incision, marcescent, lobes 2 or 4, 2–2.5 mm, deltate to linear. *Inflorescences* subcapitate, many-flowered, terminal on principal and/or axillary branches, glabrous, subsessile, subglobose, 2–4 × 2–4 cm, densely congested; basalmost (i.e., outermost) bracts often foliaceous, sometimes aggregated into an involucre; remaining bracts linear, 6–18 mm; bracteoles triangular, 2–3 mm. *Flowers* 5-merous, heterodistylous, subsessile. *Long-styled flowers:* calyx campanulate, 7–8 mm wide, glabrous, lobes 6–8 mm, linear to ligulate; corolla white, clavate in bud, when open salverform, outside glabrous or pubescent, tube to ca. 6 mm, to ca. 4 mm diam., pubescence condition inside unknown, lobes 7–10 mm, linear or ligulate, acute. *Short-styled flowers:* similar to long styled except corolla lobes

linear to ovate-oblong. *Drupes* white (Bojer, 1837) or violet-black, ellipsoid, ca. 15×10 mm; pyrenes plano-convex or ellipsoid, smooth or rugose, finely fissured, endosperm entire.

Distribution and habitat. This species grows in Mauritius. Here, it is known from heathlike vegetation on lava flows ("groundwater laterite") at elevations of 550–650 m.

Phenology. This species has been collected with flowers May through August, and with fruits January through May and in December.

Discussion. Baker (1877) treated *Gaertnera cuneifolia* as a synonym of *G. rotundifolia*, but Verdcourt (1983, 1989) recognized these as distinct species. Both species are only known from the distinctive heathlike vegetation found on local lava flows, and, unlike most *Gaertnera*, species grow there exposed to full sun (D. Lorence, pers. comm.). *Gaertnera cuneifolia* differs from *G. rotundifolia* in its elliptic-oblong, obovate, or cuneiform leaves with the tertiary venation flattened and invisible adaxially, its inflorescences with well-developed, usually involucre bracts, and its calyx lobes 6–8 mm long. In contrast, *G. rotundifolia* has broadly elliptic to obovate or ovate leaves with the tertiary venation sometimes elevated and evident adaxially, reduced bracts, and calyx lobes 1–2 mm long. The basalmost inflorescence bracts do not appear to be fused on most specimens, but do overlap widely and largely enclose the inflorescences. Field studies indicate that the two species also differ in phenology: *G. cuneifolia* flowers May through August, whereas *G. rotundifolia* flowers November through January. *Gaertnera cuneifolia* was listed as rare by Walter and Gillett (1998) and is apparently restricted to Black River Gorges National Park near Le Pétrin and environs.

Bojer suggested tentatively in the protologue that this species may be the same as *Chassalia coffeoides* DC., but did not positively accept that synonymy. Thus, this name seems validly published; *C. coffeoides* is treated here as a synonym of *Gaertnera psychotrioides*.

Representative specimens examined. MAURITIUS. Black River Gorges National Park, Lorence M 278 (MO), Malcomber 2940 (MO), Vaughan MAU 11894 (K, MAU); Plaine Champagne, Tirvengadam 969 (K).

16. *Gaertnera darcyana* Malcomber & A. P. Davis, *Monogr. Syst. Bot. Missouri Bot. Gard.* 104: 384, fig. 2. 2005. TYPE: Madagascar. Toamasina: 11.9 km N of Andasibe, Mantadia National Park, $18^{\circ}49'S$, $48^{\circ}26'E$, 930 m, 21 Nov. 1997, S. T. Malcomber 2921 (holotype, MO-5714898!; isotypes, BR!, K!, P!, TEF!, WAG!).

Shrubs, to 5 m tall, sometimes clambering; *branches* terete to flattened, glabrous, 2–4 mm diam.; internodes 1.4–6.5 cm, smooth or with a longitudinal furrow. *Leaf* blades 4–6.5 \times 0.7–3.2 cm, linear-lanceolate to elliptic or lanceolate-elliptic, apex cuspidate or acuminate, base cuneate to rounded, drying chartaceous, glabrous; secondary veins flat to prominulous abaxially, 4 to 7 pairs; domatia absent; petioles 0.1–1.1 mm. *Stipules* tubular, glabrous, chartaceous, caducous or deciduous through fragmentation, tube 1.7–12 mm, with ribs 4, narrowly winged, arising beneath petiole and sometimes extending to apex, apex entire or with 1 or 2 incisions, marcescent, lobes 4, 1.4–2.2 mm, linear. *Inflorescences* cymose, 3- to 9-flowered, terminal on axillary branches, glabrous, sessile or peduncle 1.2–2.1 cm; branched portion when present corymbiform, 0.8–2 \times 0.4–2.5 cm, branched to 1 to 2 orders, lax; bracts deltate to linear or trifid, 2.5–8.6 mm; bracteoles reduced; pedicels 2–6 mm. *Flowers* 5-merous, presumably heterodistylous. *Long-styled flowers*: not seen. *Short-styled flowers*: calyx cup-shaped, 2–3.2 mm wide, glabrous, lobes unequal, 0.4–3.1 mm, triangular to narrowly spatulate or linear; corolla white, in bud clavate, when open tubular-funnelform, outside glabrous; tube ca. 4 mm, ca. 1.5 mm diam., villous in upper part, lobes ca. 2.2 mm, triangular, acute; anthers exerted, filaments inserted in upper part of tube, ca. 1.5 mm; style ca. 2.5 mm, stigmas ca. 1.2 mm. *Drupes* violet-black, subglobose to didymous, 6.5–7.5 \times 5.2–8.2 mm; pyrenes spherical to hemispherical, rugose, finely fissured, endosperm ruminant.

Distribution and habitat. This species grows in Madagascar, where it is known from the provinces of Toamasina and Fianarantsoa. It is so far known only as a rare species found in humid evergreen forests on metamorphic and igneous rocks, at elevations of 700–1400 m.

Phenology. This species has been collected with flowers in November and December and has been collected with fruits, but the months of those collections have not been recorded.

Discussion. *Gaertnera darcyana* differs from other *Gaertnera* species in its few-flowered inflorescences, calyptrate stipules, and rather well-developed, narrow calyx lobes. Malcomber and Davis (2005) considered the conservation status of this species to be Vulnerable (IUCN, 2001).

Representative specimens examined. MADAGASCAR. **Fianarantsoa:** Haute vallée de la Rienana, Bassin du Matitanana, Humbert 3566 (P). **Toamasina:** Ambodiniana, Cours 1926 (P).

17. *Gaertnera divaricata* (Thwaites) Thwaites, *Enum. Pl. Zeyl.* 425. 1864. Basionym: *Pristidia*

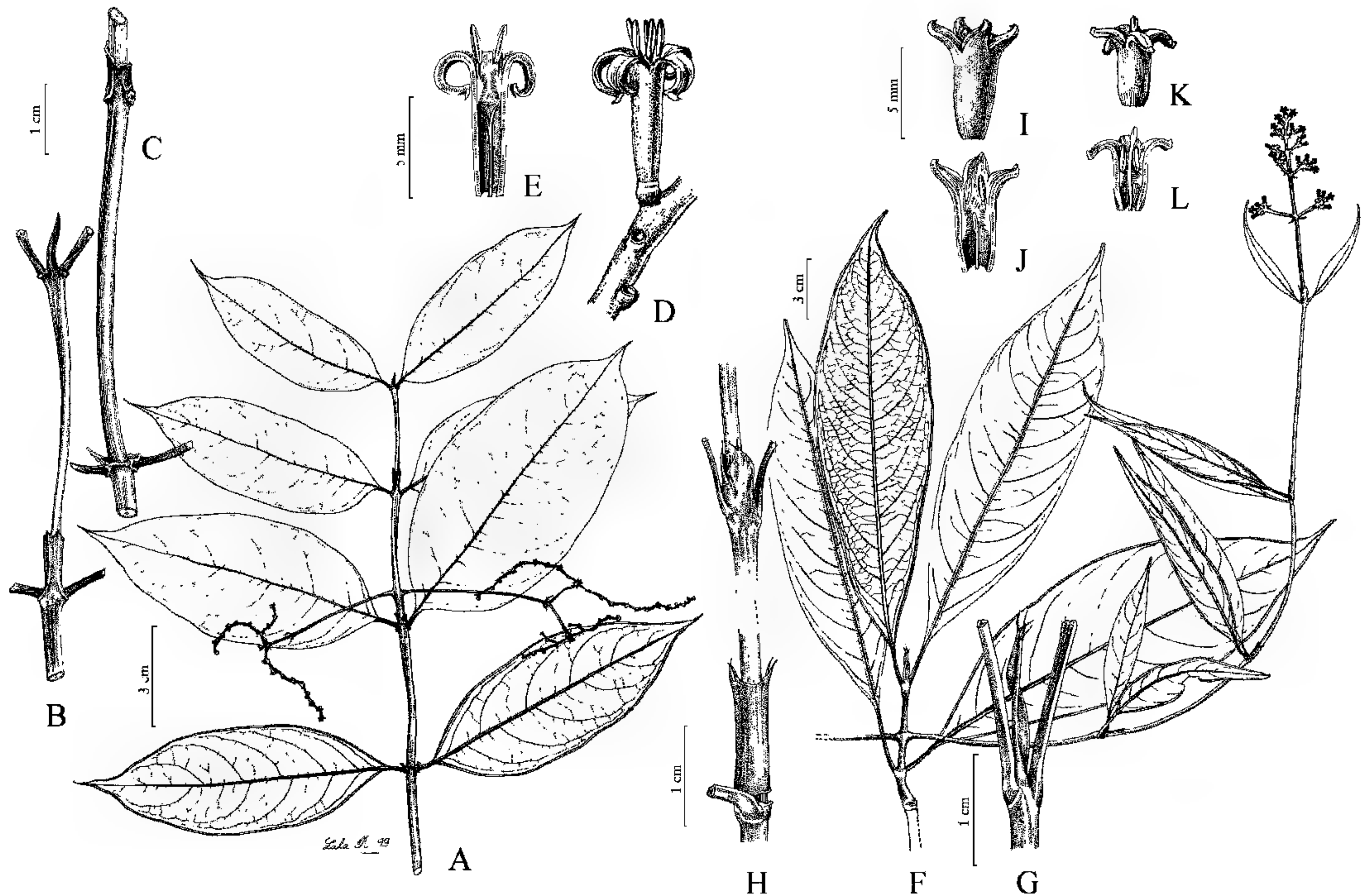

Figure 8. A–E. *Gaertnera divaricata* (Thwaites) Thwaites. —A. Young fruiting branch. —B. Portion of stem with petiole bases, stipules, and stem apex. —C. Portion of stem with petiole bases and old stipules. —D. Portion of inflorescence axis with short-styled flower. —E. Short-styled flower in cross section. F–L. *Gaertnera inflexa* Baill. —F. Flowering branch (to 3-cm scale). —G. Stem apex with petiole bases and stipules. —H. Portion of stem with petiole bases and stipules. —I. Short-styled flower. —J. Short-styled flower in cross section. —K. Long-styled flower. —L. Long-styled flower in cross section. B, C to same 1-cm scale; D, E to same 5-mm scale; I–L to same 5-mm scale. A–E based on *Malcomber 2762*; F–L based on *Malcomber 2900*.

divaricata Thwaites, Enum. Pl. Zeyl. 149. 1859.
Gaertnera koenigii var. *divaricata* (Thwaites) C.
B. Clarke, in Hook. f., Fl. Brit. India 4: 91. 1883.
TYPE: Sri Lanka. Near Galle, G. H. K. Thwaites
CP 2991 (holotype, K!; isotypes, BM!, BR!,
CGE!, G!, K!, P!, PDA!, W!, WU!). Figure 8A–E.

Trees, 1.5–3 m tall; branches flattened at apex, otherwise terete, glabrous, 1.5–3 mm diam.; internodes 3–10.5 cm, smooth. Leaf blades (4–)7.5–16 × (2–)2.8–8.5 cm, lanceolate to elliptic, elliptic-obovate, or obovate, apex acuminate to cuspidate, base cuneate or obtuse, drying chartaceous, glabrous; secondary veins flat and hardly or not visible abaxially, 4 to 6 pairs; domatia absent; petioles 3–12 mm. Stipules tubular, glabrous, drying chartaceous, caducous, tube (3–)6–9 mm, with ribs none or 4, narrowly winged, encircling base of petiole but not extending up tube, apex entire, marcescent, lobes 4, 0.5–1 mm, deltate. Inflorescences cymose, many-flowered, axillary or supra-axillary on principal branches, pendulous, glabrous; peduncle 3–7 cm; branched portion corymbiform to pyramidal, 1.3–9 × 2–9(–12) cm, lax, branched to 3 to 6 orders; axes

dichasial at basal nodes becoming scorpioid at distal nodes; bracts deltate to linear, 0.5–4 mm; bracteoles reduced; pedicels absent or to 1 mm. Flowers 4-merous, heterodistylous. Long-styled flowers: calyx cup-shaped, 1–2 mm wide, glabrous outside, with hair-ring inside, truncate to denticulate with teeth to 0.2 mm; corolla white, clavate in bud, when open salverform, outside glabrous, tube 4–5.1 mm, 1–2.5 mm diam., inside villous in upper third, lobes 2.5–4 mm, ligulate or triangular, acute; anthers shortly exserted, filaments inserted in upper third of corolla tube, ca. 0.5 mm; style 5–5.5 mm, glabrous, stigmas 0.5–1 mm. Short-styled flowers: similar to long styled except corolla tube 4.5–5.5 mm, 1–2 mm diam., lobes 2–3.5 mm; filaments 0.5–1.5 mm; style 2.5–3.5 mm, stigmas 1–1.5 mm. Drupes violet-black, subglobose or obovoid, 14–17 × 10–12 mm; pyrenes spherical or hemispherical, rugose, finely fissured, endosperm entire.

Distribution and habitat. This species grows in Sri Lanka, where it is known from the district of Galle. Here, it has been found in humid forests at elevations of ca. 900 m.

Phenology. This species has been collected with flowers September through November, and with fruits January through August.

Discussion. *Gaertnera divaricata* is a distinctive species with axillary or supra-axillary inflorescences with scorpioid axes and 4-merous flowers. The species is locally common around Hiniduma, particularly in Kanneliya Forest Reserve.

Representative specimens examined. SRI LANKA. **Galle:** Halwitigala, *Waas 1316* (K, MO, PDA); Hiniduma, Kanneliya Forest Reserve, *Faden 76/503* (PDA), *Huber 582* (E, PDA), *Jayasuriya 1509* (K, MO, PDA), *Kostermans 27135* (G, L).

18. *Gaertnera diversifolia* Ridl., J. Fed. Malay States Mus. 6: 163. 1915. *Gaertnera oblanceolata* var. *diversifolia* (Ridl.) Beusekom, Blumea 15: 384. 1967. TYPE: Malaysia. Selangor: Bukit Etam, 1891, *H. J. Kelsall 1995* (lectotype, designated by van Beusekom, 1967 [1968]: 383, SING!). [SYNTYPE: Malaysia, *H. N. Ridley 7429* (SING!).]

Gaertnera intermedia Ridl., J. Fed. Malay States Mus. 6: 163. 1915. TYPE: Malaysia. Selangor: Hulu Semangko, Aug. 1904, *H. N. Ridley 12080* (holotype, SING!).

Gaertnera lanceolata Ridl., J. Fed. Malay States Mus. 6: 162. 1915, hom. illeg., non *Gaertnera lanceolata* Bouton ex A. DC., 1845. *Gaertnera oblanceolata* Ridl., J. Linn. Soc., Bot. 38: 317. 1908, hom. illeg., non *Gaertnera oblanceolata* King & Gamble, 1907. TYPE: Malaysia. Pahang: Gunong Tahan, June 1905, *L. Wray, Jr. and H. G. Robinson 5343* (lectotype, designated by van Beusekom, 1967 [1968]: 383, SING!). [SYNTYPE: Malaysia, *H. N. Ridley 16255* (syntype, SING!).]

Gaertnera ovata Ridl., J. Straits Branch Roy. Asiat. Soc. 86: 301. 1922. TYPE: Malaysia. Selangor: Semangkok Pass, *H. N. Ridley s.n.* (holotype, K!).

Gaertnera rigida Ridl., J. Straits Branch Roy. Asiat. Soc. 86: 301. 1922. TYPE: Malaysia. Negeri Sembilan: Bukit Tangga, *H. N. Ridley s.n.* (holotype, K!).

Gaertnera latifolia Ridl., J. Bot. 62: 299. 1924. TYPE: Malaysia. Selangor: Fraser's Hill, Sep. 1922, *I. Burkill & R. E. Holttum 8608* (holotype, SING!).

Trees or shrubs, 0.5–3 m tall; *branches* terete to quadrangular, glabrous, 1–6 mm diam.; internodes 3–5.5 cm, smooth. *Leaf* blades 10–30 × 2–11 cm, oblanceolate to obovate, apex shortly acuminate or acute, base acute to attenuate to cuneate, drying coriaceous, glabrous; secondary veins prominent abaxially, 5 to 15 pairs; domatia absent; petioles 12–40 mm. *Stipules* tubular, glabrous, variously persistent, caducous, or deciduous through fragmentation sometimes leaving a truncate base 1–8 mm, tube 8–18 mm, with ribs 4, narrowly to broadly winged, arising below petiole and extending along tube to lobes, apex with 2 incisions, marcescent, lobes 2 or 4, 1–4 mm, narrowly triangular to deltate. *Inflorescences* cymose, many-flowered, terminal on

axillary and/or supra-axillary branches, puberulent to pilosulose, pendulous; peduncle 1.3–5 cm; branched portion narrowly pyramidal, 2–7.5 × 4.6–6.5 cm, lax, branched to 3 or 4 orders; bracts and bracteoles reduced; pedicel 1–2 mm. *Supra-axillary* branches when present pendulous, up to 45 cm, 1–2 mm diam., with reduced leaves (0.2–)4–8(–15) × (0.1–)0.9–2 (–2.5) cm, linear to narrowly elliptic or oblanceolate, drying chartaceous; secondary veins prominulous abaxially, 4 to 8 pairs; petiole 1–10 mm. *Flowers* 5-merous, unisexual. *Pistillate flowers:* calyx cup-shaped, 1.5–3.5 mm wide, outside glabrous or puberulent, with hair-ring inside, truncate or lobes to 0.2 mm, broadly triangular; corolla white, in bud clavate, outside glabrous or puberulent, mature corolla, staminodes, and stigmas unknown. *Staminate flowers:* similar to pistillate as far as known, corolla villous inside in upper third. *Drupes* violet-black, didymous or globose, 7–8 × 7–9 mm; pyrenes spherical or hemispherical, rugose, finely fissured, endosperm entire.

Distribution and habitat. This species grows in Southeast Asia, where it is known in Peninsular Malaysia and Borneo; in Borneo it is known from the Brunei, Kalimantan (Malaysia), and Sarawak (Indonesia) sectors. Here, it has been found in humid forests at elevations of 130–1450 m.

Phenology. This species has been collected with flowers January through September, and with fruits January through May and July through December.

Discussion. *Gaertnera diversifolia* is a widespread, locally common species within Peninsular Malaysia and Borneo and is recognized by its narrowly pyramidal inflorescences often borne on pendulous supra-axillary branches and its 5-merous flowers. It is similar to *G. inflexa* of Madagascar, but differs from that by its 5-merous unisexual flowers. *Gaertnera diversifolia* was treated by van Beusekom (1967) as a variety of *G. oblanceolata*, but these are treated as two species here.

Representative specimens examined. BRUNEI DARUS-SALAM. **Belait:** Batu Patam, *Wong 1088* (A, BRUN, K, KEP, L, SAN). INDONESIA. **Kalimantan:** Bukit Raya, *Nooteboom 4324* (L). MALAYSIA. **Johor:** Buaya Sangkut, *Saw FRI 34247* (A, K, L, SAN, SING). **Negeri Sembilan:** Gunong Angsi, *Nur 11613* (L, SING). **Pahang:** Pine Tree Hill, *Malcomber 3018* (MO), *3019* (MO), *Ng FRI 1935* (K, KEP). **Sabah:** Ranau Distr., Tenompok Ridge, park headquarters, *Beaman 8215* (L). **Sarawak:** Miri, Suai, *Ilias S. 39183* (K, L, SAN, SAR). **Selangor:** Ulu Terengganu, *Ng FRI 22056* (KEP).

19. *Gaertnera drakeana* Aug. DC., Bull. Herb. Boissier, Sér. 2, 1: 586. 1901. TYPE: Madagascar. Toamasina: Maroa [Maroantsetra], in forest,

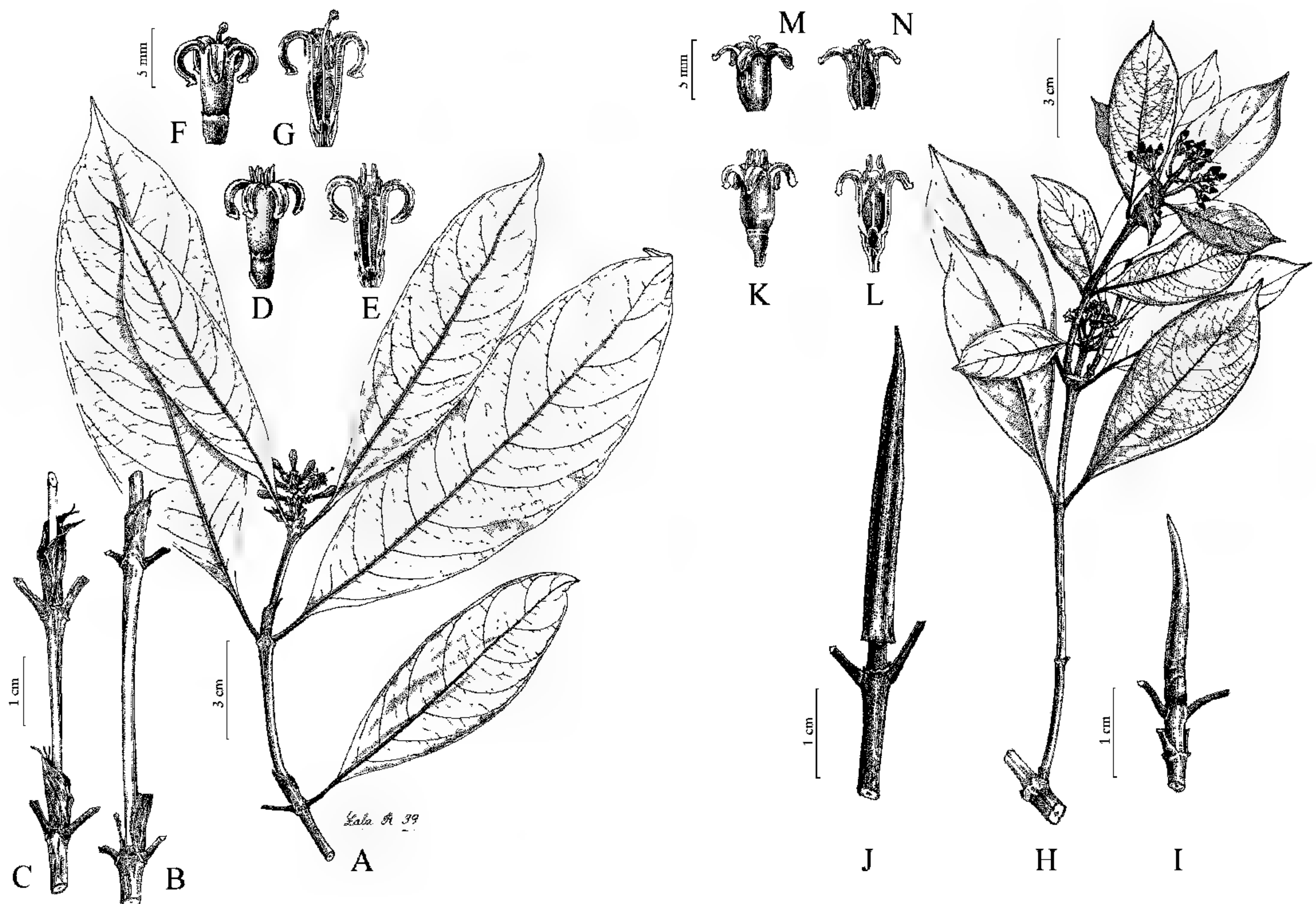

Figure 9. A–G. *Gaertnera drakeana* Aug. DC. —A. Flowering branch. —B, C. Portions of stems with petiole bases and stipules. —D. Short-styled flower. —E. Short-styled flower in cross section. —F. Long-styled flower. —G. Long-styled flower in cross section. H–N. *Gaertnera guillotii* Hochr. —H. Flowering branch (to 3-cm scale). —I, J. Portions of stems with petiole and apical stipules. —K. Short-styled flower. —L. Short-styled flower in cross section. —M. Long-styled flower. —N. Long-styled flower in cross section. B, C to same 1-cm scale; D–G to same 5-mm scale; K–N to same 5-mm scale. A–G based on *Moise 2*; H–N based on *Malcomber 2913*.

1897, *A. Mocquerys* 273 (holotype, G-DC!).
Figure 9A–G.

Trees, 0.3–6 m tall; *branches* flattened to terete, glabrous, 1.5–4 mm diam.; internodes (0.3–)2.8–7 (–11.3) cm, smooth. *Leaf* blades 5.5–16 × 1.5–4.8 cm, narrowly elliptic to oblanceolate, apex acuminate or cuspidate, base acute or cuneate, drying chartaceous, glabrous; secondary veins prominulous abaxially, 9 to 12 pairs; domatia absent; petioles 5–11 mm. *Stipules* tubular, glabrous, drying membranous, caducous or deciduous through fragmentation, tube 4.7–18 mm, with ribs 4, rounded to narrowly winged, arising below petiole and extending to lobes, apex with 1 or 2 shallow to deep incisions, marcescent, lobes 4, 2.1–5 mm, deltate or linear. *Inflorescences* subcapitate to cymose, several-flowered, terminal on principal and/or axillary branches, deflexed to pendulous, glabrous, sessile or peduncle to 2.7 cm; branched portion subglobose, 1.2–2.5 × 1.1–2.1 cm, branched to 2 to 3 orders, congested; bracts deltate, 0.5–1 mm; bracteoles ovate to triangular, 0.5–1 mm. *Flowers* 5-merous, heterodistylous, subsessile. *Long-styled flowers*: calyx cup-shaped, 2–

3.5 mm wide, glabrous, lobes 0.3–0.6 mm, triangular; corolla white, clavate in bud, when open salverform, outside glabrous, tube 6–7 mm, 1.5–4 mm diam., inside villous at ca. middle, lobes 4–7 mm, triangular or ligulate, acute; anthers included, filaments inserted in upper third of corolla tube, 0.2–0.5 mm; style 9–10 mm, glabrous, stigma 1–1.5 mm. *Short-styled flowers*: similar to long styled except calyx 2.2–3.5 mm wide, lobes 0.3–0.7 mm; corolla tube 6.5–8 mm, 2–4.5 mm diam., lobes 5.5–7 mm; anthers shortly exserted, filaments 3–4 mm; style 4–5 mm, stigma 1.5–1.8 mm. *Drupes* violet-black or blue, globose to subglobose or didymous, 7–10 × 7–10 mm; pyrenes spherical or hemispherical, rugose, finely fissured, endosperm entire.

Distribution and habitat. This species grows in Madagascar, where it has been found in the province of Toamasina in the Mananara-Nord and Masoala National Parks. Here, it grows in humid forest at 0–300 m.

Phenology. This species has been collected with flowers August through December and has been collected in fruit, but the dates of those collections were not noted.

Discussion. *Gaertnera drakeana* is an infrequently collected but locally common species that is apparently restricted to Mananara-Nord and Masoala National Parks in northeastern Madagascar. The species is diagnosed by its stipules drying membranous and its relatively small subglobose inflorescences. The species is similar to *G. sralensis* of southeastern Asia, but differs from that in the absence of a hair-ring in the calyx tube and its larger flowers.

Representative specimens examined. MADAGASCAR. **Toamasina:** Mananara-Nord Nature Reserve, *Raharimalala 1502* (P); Masoala National Park, *Malcomber 2802* (MO), *2822* (MO).

20. *Gaertnera edentata* Bojer, Hortus Maurit. 216. 1837. *Sykesia edentata* (Bojer) Kuntze, Revis. Gen. Pl. 2: 425. 1891. TYPE: Mauritius. Forêts de la Nouvelle Découverte au Quartier-Militaire & montagnes du Grand-Port, *W. Bojer s.n.* (holotype, P not located; isotypes, G!, MAU!). Figure 10C–I.

Gaertnera petrinensis Verdc., Kew Bull. 37: 538. 1983, syn. nov. TYPE: Mauritius. Petrin, *L. Bernardi 14794* (holotype, K!; isotypes, G!, P!).

Trees or shrubs, (1–)1.5–3 m tall; branches flattened to terete, glabrous, 2–7.5 mm diam.; internodes (0.4–)0.9–2.8 cm, smooth. Leaf blades 2–10 × (1.1–)1.7–5 cm, elliptic to oblong, apex acuminate or acute, base acute to obtuse or rarely subcordate, drying coriaceous, glabrous; secondary veins visible and flat to prominulous abaxially, 4 to 9 pairs; domatia absent; petioles 2.5–20(–30) mm. Stipules tubular, glabrous to puberulent, drying chartaceous, caducous or persistent on distalmost 1 to 4 nodes, tube 2–5 mm, with ribs 4, narrowly winged, arising below petiole and sometimes extending to lobes, apex entire, marcescent, lobes 4, 3–4(–8) mm, linear; setae absent or 2 to 6, 1–3 mm. Inflorescences cymose to subcapitate, (few-to) many-flowered, terminal on principal and/or axillary branches, glabrous; peduncle 0.7–3.5 cm; branched portion corymbiform, (1–)2–4 × (2–)3–6 cm, branched to 2 to 3 orders, congested; bracts deltate or trifid, 2–15 mm, glabrous; bracteoles inserted at base of calyx, ovate to triangular, 1–2 mm; pedicels absent or to 1 mm. Flowers 5-merous, heterodistylous. Long-styled flowers: calyx cup-shaped, 3–5 mm wide, glabrous, truncate or lobes to 0.6 mm, triangular; corolla white, in bud clavate, lobed apically with linear to elliptic appendages 1–2 mm, when open infundibuliform or salverform, outside glabrous, tube 10–25 mm, 4–6 mm diam., inside glabrous or villous in upper third, lobes 7–10 mm, ligulate to linear, acute; anthers included, filaments inserted in upper third of corolla tube, ca. 1 mm; style 9–25 mm, glabrous, stigma 1–4 mm.

Short-styled flowers: similar to long styled except corolla tube 11–25 mm, 3–5 mm diam., lobes 8–10 mm; anthers shortly exerted, filaments inserted in upper third of corolla tube, ca. 2 mm; style 5–9 mm, glabrous, stigma 1–2.5 mm. Drupes white (Bojer, 1837) or violet-black to blue, ellipsoid, 6–10 × 5–7 mm; pyrenes ellipsoid or hemispherical to plano-convex, rugose, finely fissured, endosperm ruminant.

Distribution and habitat. This species grows in Mauritius, where it is found in evergreen wet forests and in the heathlike vegetation found on lava (“groundwater laterite”) at elevations of 300–700 m.

Phenology. This species has been collected with flowers January through May and October through December, and with fruits May through September.

Discussion. *Gaertnera edentata* is an attractive species with the largest flowers in the genus. The apex of the stipule may or may not have setae, but four lobes are consistently present. This species differs from *G. hirtiflora* in its externally glabrous corolla, and from *G. psychotrioides* in its congested rather than lax inflorescences and larger flowers. The label data of *Lorence 1554* and *2201* note that the flowers are fragrant; these were collected in the middle of the day (D. H. Lorence, pers. comm.).

Verdcourt (1989) separated *Gaertnera petrinensis* as a relatively localized species or form found in the heathlike vegetation that grows on lava flora on Mauritius. He separated this based on its calyx 3–4 mm long and undulate to shortly lobed, with the lobes up to 1 mm long versus 4–5 mm long and truncate to undulate in his circumscription of *G. edentata*. However, the variation in these features on the species studied appears to be continuous and not correlated with habitat. At least one other *Gaertnera* species as circumscribed by Verdcourt and in this treatment is found in both wet forests and the low heathlike vegetation (*G. psychotrioides*), and this name is considered a synonym here.

Representative specimens examined. MAURITIUS. Curepipe, *Vaughan MAU 1636* (MAU); Perrier Nature Reserve, *Tirvengadam 28* (P), *Vaughan MAU 14222* (MAU); Plaine Champagne, *Lorence 2201* (MAU, MO, P), *4423* (MO); Black River Gorges National Park, *Malcomber 2941* (MO), *2942* (MO), *2943* (MO), *2944* (MO), *2945* (MO), *2948* (MO), *2950* (MO), *2954* (MO), *2960* (MO), *2961* (MO), *2962* (MO), *2963* (MO); Petrin Reserve, *Lorence 131* (MO), *1554* (MO), *2376* (MO), *2613* (MO), *Tirvengadam 394/44* (MAU, US).

21. *Gaertnera eketensis* Wernham, J. Bot. 52: 30. 1914. TYPE: Nigeria. South Eastern State [Akwa Ibom]: Eket Distr., 1912–1913, *P. A. Talbot 3391* (holotype, BM! isotype, K!).

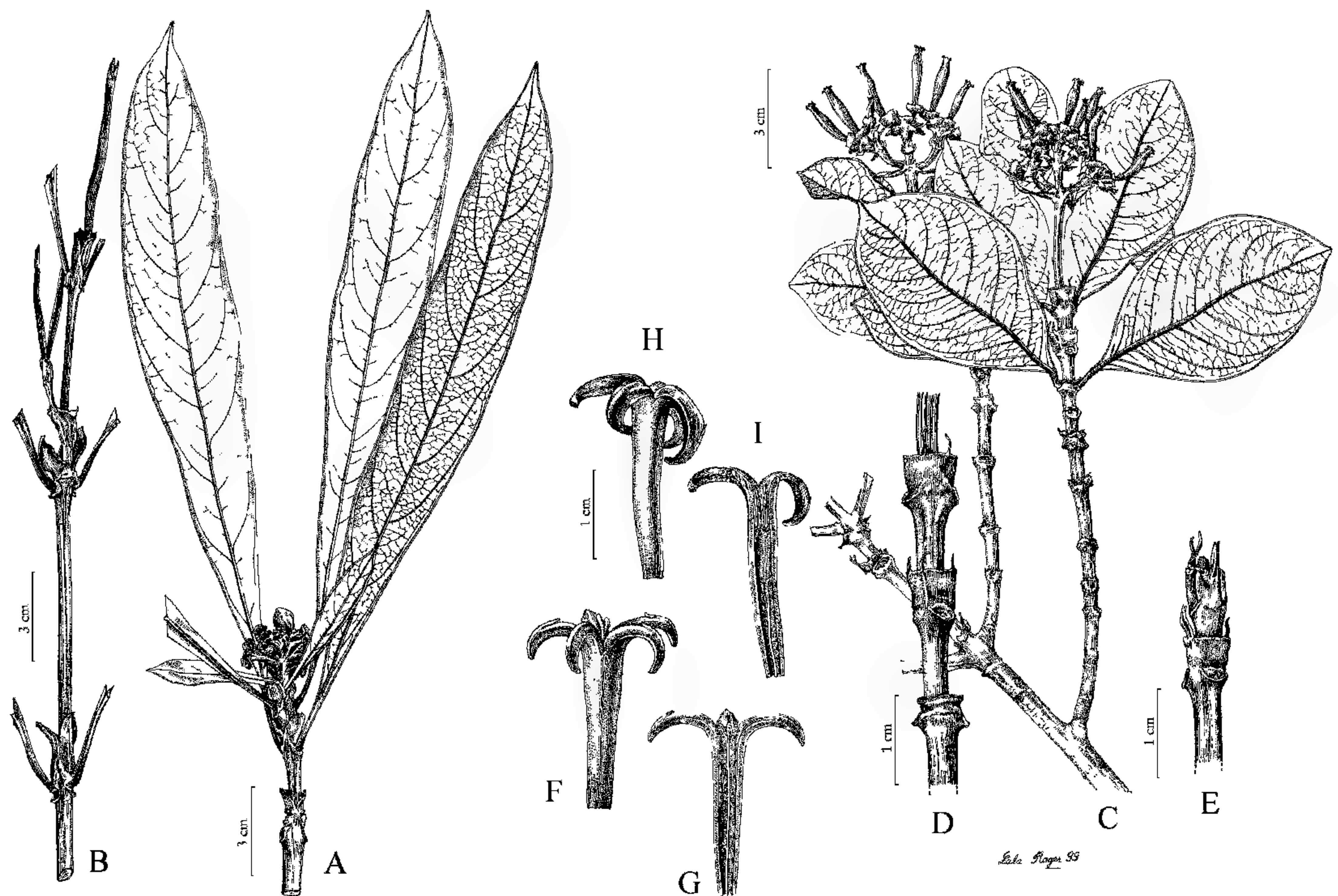

Figure 10. A, B. *Gaertnera globigera* Beusekom. —A. Fruiting branch. —B. Portion of stem with petiole bases, stipules, and stem apex with young leaves. C–I. *Gaertnera edentata* Bojer. —C. Flowering branch (to 3-cm scale). —D, E. Portions of stems with stipules. —F. Long-styled flower. —G. Long-styled flower in cross section. —H. Short-styled flower. —I. Short-styled flower in cross section. F–I to same 1-cm scale. A, B based on *Malcomber 3038*; C–I based on *Malcomber 2954*.

Trees, height not noted; bark with longitudinal striations or fissures; *branches* terete, glabrous, 1.5–3 mm diam.; internodes 1.6–5 cm, smooth to shortly ridged. *Leaf* blades 8–12 × 3–4 cm, elliptic to obovate, apex cuspidate or acuminate, base cuneate, drying chartaceous, glabrous; secondary veins visible abaxially, 4 to 6 pairs; domatia present; petioles 3–6 mm. *Stipules* tubular, glabrous, drying membranous, caducous, tube 4–10 mm, with ribs 6, 4 of them narrowly winged, arising below petiole and extending to lobes, 2 ribs extending from longitudinal ribs of internodes to apex between lobes, apex entire, marcescent, lobes 4, 4–6 mm, linear to filiform; setae numerous, 0.5–2 mm. *Inflorescences* cymose, many-flowered, terminal on principal and/or axillary branches, sparsely puberulent to glabrescent, sessile or peduncle to 4.2 cm; branched portion corymbiform, 3–5.5 × 3–7 cm, branched to 3 to 4 orders, lax; bracts deltate or trifid, 1–4.5 mm; bracteoles reduced; pedicels absent or to 0.8 mm. *Flowers* 5-merous, heterodistylous. *Long-styled flowers*: calyx cup-shaped, 1.1–2 mm wide, glabrous, truncate or lobes to 0.6 mm, triangular; corolla white, clavate in bud, when open salverform, externally glabrous, tube ca. 3.5 mm, 0.8–2 mm diam., inside villous in upper

third, lobes 2.5–3 mm, triangular to ligulate, acute; anthers shortly exerted, filaments inserted in upper third of corolla tube, 0.1–0.3 mm; style 2.7–3 mm, glabrous, stigma 0.6–1 mm. *Short-styled flowers*: unknown. *Drupes* unknown.

Distribution and habitat. This species grows in West Africa, where it is found to the east of the Dahomey Gap in Nigeria. Here, it can be found in humid lowland forests, but the elevations at which it has been found have not been recorded.

Phenology. This species has been collected with flowers in April and May but has not yet been found with fruits.

Discussion. This poorly known species is so far documented in three collections. Hutchinson and Dalziel (1937) considered *Gaertnera eketensis* a synonym of *G. paniculata*, but, as noted by Petit (1959b), these are distinct. The stipules with numerous setae and the brown-black bark with prominent longitudinal fissures distinguish this species from *G. paniculata*, which lacks both of those features. *Gaertnera eketensis* is similar to *G. liberiensis*, as also noted by Petit (1959b); see comments about their separation under this latter species. Petit also considered *G. eketensis* similar to *G.*

stictophylla (Hiern) E. M. A. Petit; however, the identity of the latter has not been established here, and that name is treated here as doubtful as to application.

Additional specimens examined. NIGERIA. **South Eastern State [Akwa Ibom]:** 30 km E of Eket, Stubbs Creek Forest Reserve, *van Meer 1174* (WAG), *Onochie FIH 33168* (WAG).

22. *Gaertnera fractiflexa* Beusekom, *Blumea* 15: 375, fig. 8A–C. 1968. TYPE: Malaysia. Sarawak: Matang, Peakes Tea Plantation, 18 July 1890, *M. R. Haviland s.n.* (holotype, SING!).

Shrubs, 2–5 m tall; *branches* terete, glabrous, 1.5–3 mm diam.; internodes 0.5–5 cm, smooth. *Leaf* blades 4–16 × 1–4 cm, lanceolate to elliptic or narrowly elliptic-oblong, apex cuspidate or acuminate, base cuneate, drying chartaceous, glabrous; secondary veins prominulous abaxially, 4 to 8 pairs; domatia absent; petioles 3–13 mm. *Stipules* tubular, glabrous to puberulent, drying membranous, deciduous through fragmentation, tube 7–15 mm, with ribs 4, narrowly winged, arising below petiole and sometimes extending to lobes; apex with 2 incisions, marcescent, lobes 4, ca. 3 mm, deltate. *Inflorescences* cymose, many-flowered, terminal on axillary branches, glabrous, pendulous; peduncle 2.5–7 cm; branched portion broadly pyramidal, 3–11 × 3–9 cm, lax, branched to 3 to 4 orders, bracts deltate or linear, 3–30 mm; bracteoles reduced; pedicels absent or to 3 mm. *Flowers* 4-merous, unisexual. *Pistillate flowers:* calyx cup-shaped, 1.5–2.5 mm wide, outside glabrous, with hair-ring inside, truncate or lobes to 0.3 mm, triangular; corolla, staminodes, and stigmas unknown. *Staminate flowers:* calyx similar to pistillate as far as known; corolla white, clavate in bud, when open salverform, externally glabrous, tube 2–4 mm, 0.75–1.5 mm diam., inside villous in upper third, lobes 2–3 mm, ligulate, acute; anthers included, filaments inserted in upper third of corolla tube, ca. 2.5 mm; pistillode poorly developed. *Drupes* violet-black, globose or subglobose, 5–7 × 5–8 mm; pyrenes spherical or hemispherical, rugose, finely fissured, endosperm entire.

Distribution and habitat. This species grows in Southeast Asia, where it is known from Borneo, in the Sarawak (Malaysia) sector. Here, it can be found in humid forests at an elevation of ca. 145 m.

Phenology. This species has been collected with flowers, but the date of that collection was not noted; it has been collected with fruits in June.

Discussion. *Gaertnera fractiflexa* is similar to *G. junghuhniana* but differs in its pendulous, pyramidal inflorescence and 4-merous flowers. *Gaertnera fracti-*

flexa was described by van Beusekom (1967) based on only one collection, suggesting that the species might be rare and possibly now extinct, but recent fieldwork shows that *G. fractiflexa* is still extant at the type locality, although the population was limited in size and scattered.

Additional specimens examined. MALAYSIA. **Sarawak:** Matang, water catchment area, trail to Sri Maha Mariamman temple, *Malcomber 3033* (MO).

23. *Gaertnera furcellata* (Baill. ex Vatke) Malcomber & A. P. Davis, *Monogr. Syst. Bot. Missouri Bot. Gard.* 104: 386, fig. 2. 2005. Basionym: *Psychotria furcellata* Baill. ex Vatke, *Abh. Naturwiss. Vereine Bremen* 9: 118. 1885. TYPE: Madagascar. s. loc., 24 Nov. 1877, *D. C. Rutenberg s.n.* (holotype, P!).

Shrubs, to 2 m tall; *branches* terete, glabrous, 1–2 mm diam.; internodes 0.5–1.2 cm, with 2 longitudinal ribs. *Leaf* blades 0.5–1.2 × 0.3–0.5 cm, elliptic, apex acute to shortly cuspidate, base cuneate, drying membranous or chartaceous, glabrous; secondary veins not or poorly visible abaxially, 3 to 4 pairs; domatia absent; petioles absent or to 0.3 mm. *Stipules* tubular, glabrous, drying membranous, persistent whole or as 4 spatulate shreds, tube absent or up to 1 mm, with ribs 4, narrowly winged, arising below petiole and extending to lobes, apex with 4 incisions, lobes 4, 3–4 mm, linear to filiform. *Inflorescences* reduced to a single flower, terminal on axillary branches, sessile or with peduncles to 1 mm; bracteoles reduced. *Flowers* 4-merous, heterodistylous. *Long-styled flowers:* calyx campanulate, 1.5–2 mm wide, outside glabrous, with hair-ring inside, lobes 0.5–2.5 mm, triangular to linear; corolla white, clavate in bud, when open salverform, outside glabrous, tube 2.5–3 mm, 1.2–1.7 mm diam., inside villous in upper third, lobes 2.2–2.8 mm, ligulate to linear, acute or rounded; anthers included, filaments inserted in upper third of corolla tube, ca. 0.3 mm; style ca. 5 mm, glabrous, stigma 0.5–0.7 mm. *Short-styled flowers:* unknown. *Drupes* unknown.

Distribution and habitat. This species grows in Madagascar, where it is known from Toamasina Province. Here, it can be found in evergreen humid forests on metamorphic and igneous rocks at an elevation of ca. 900 m.

Phenology. This species has been collected with flowers in November, but has not yet been collected with fruits.

Discussion. *Gaertnera furcellata* is similar to *G. microphylla*. These poorly known species share calyptrate stipules that usually persist as four mem-

branous shreds at the leaf nodes and inflorescences reduced to a single flower; for further discussion, see the section for this latter species. This species was treated under the unpublished name “*Gaertnera lacerata*” by Malcomber (2000). Malcomber and Davis (2005) considered the conservation status of this species to be Critically Endangered (IUCN, 2001).

Additional specimens examined. MADAGASCAR. **Toamasina:** Samalahaza, Ambatondrazaka, *Cours 1203* (P), *Dequaire 27977* (K, P).

24. *Gaertnera gabonensis* Malcomber, sp. nov.
TYPE: Gabon. Iwateki, 15 Dec. 1930, *G. Le Testu 8575* (holotype, P!; isotypes, BM!, BR!, MO!).

Haec species *Gaertnerae spicatae* K. Schum. similis, sed ab ea inflorescentia thyrsiformi atque calyce dense puberulo vel pilosulo distinguitur.

Trees or shrubs; *branches* terete to \pm tetragonal, hollow, densely puberulent or pilosulose to glabrescent, 3–6 mm diam.; internodes 7–9 cm, smooth. *Leaf* blades 21–30 \times 8–11 cm, oblanceolate to elliptic-oblong, apex rounded then abruptly shortly cuspidate, base cuneate to obtuse, drying stiffly chartaceous, glabrous; secondary veins prominulous abaxially, 8 to 10 pairs; domatia absent; petioles 15–25 mm. *Stipules* tubular, densely hirtellous or pilosulose to glabrous, drying chartaceous, deciduous through fragmentation, tube 15–25 mm, with ribs 4, broadly winged, arising below petiole and extending to lobes, apex with 2 incisions, marcescent, lobes 4, 4–8 mm, deltate to linear. *Inflorescences* cymose, many-flowered, terminal on principal branches, puberulent to pilosulose; peduncle 5–9 cm; branched portion corymbiform to broadly pyramidal, 4.5–10 \times 4–8 cm, branched to 3 to 5 orders, rather congested; bracts deltate or trifid, 5–12 mm; bracteoles reduced. *Flowers* 5-merous, bisexual, heterodistylous, subsessile. *Long-styled flowers:* calyx cup-shaped, 2–3.5 mm wide, outside densely puberulent to pilosulose, glabrous inside, truncate or lobes to 1.2 mm, triangular to linear; corolla white, clavate in bud, when open salverform, outside densely puberulent to pilosulose, tube 6–9 mm, 1.4–2.1 mm diam., inside villous in upper third, lobes 3.5–4.5 mm, elliptic-oblong, acute; anthers included, filaments inserted in upper third of corolla tube, ca. 0.3 mm; style 7–9 mm, glabrous, stigma 1.5–2.5 mm. *Short-styled flowers:* similar to long styled except corolla glabrous outside, tube 7–8.5 mm, 1.1–2 mm diam., inside villous in upper third, lobes 2–3 mm, ligulate; anthers fully exerted, filaments 3–4 mm; style 7–8 mm, stigma 1–1.5 mm. *Drupes* unknown.

Distribution and habitat. This species grows in Central Africa, where it is known from Gabon. Here, it

can be found in humid forests at elevations of 30–700 m.

Phenology. This species has been collected with flowers September through December, and with fruits in January, November, and December.

Discussion. *Gaertnera gabonensis* is often confused with *G. spicata*, but differs in the absence of stipule setae, its corymbiform to broadly pyramidal inflorescences, and its densely puberulent to pilosulose calyx tubes. The specific epithet refers to the geographic distribution, which is apparently restricted to Gabon.

Paratypes. GABON. **Ngounié:** Betw. Mouila & Yeno, 60 km from Mouila, *Breteler 8029* (K, WAG). **Nyanga:** Mayombe bayaka, Issala, *Le Testu 1642* (BM, BR, P); Near Rabi, *Van Nek 569* (WAG). **Ogooué Maritime:** Rabi-Kounga, *Breteler 10214* (WAG), 9 Nov. 1991, *Schoenmaker 117* (WAG), 4 km N of Shell camp, *Wieringa 1654* (WAG).

25. *Gaertnera* \times *gardneri* Thwaites, Enum. Pl. Zeyl. 202. 1864. *Gaertnera walkeri* var. *gardneri* (Thwaites) C. B. Clarke, in Hook. f., Fl. Brit. India 4: 92. 1883. TYPE: Sri Lanka. Central Province: Adam’s Peak, *G. H. K. Thwaites CP 346* (lectotype, designated by van Beusekom, 1967 [1968]: 380, BM!; isotypes, G!, PDA!, W!). [SYNTYPE: Sri Lanka, *G. H. K. Thwaites CP 363* (K!).]

Trees, 2–4 m tall; *branches* terete to flattened or trigonous, when young puberulent or hirtellous to glabrous with indumentum drying yellow or gray-white, becoming glabrescent, 1–5 mm diam.; internodes 0.6–1.5(–2.4) cm, smooth or with 2 or 3 longitudinal ribs. *Leaves* paired or ternate; blades 1.5–3.7(–4.7) \times 0.4–0.8(–1.2) cm, narrowly elliptic to linear-lanceolate, apex cuspidate, base attenuate to cuneate, drying chartaceous, glabrous, margin flat to thinly revolute; secondary veins invisible or visible but flat abaxially, 3 to 6 pairs; domatia absent; petioles 1–3 mm. *Stipules* tubular, glabrous to puberulent, drying chartaceous, caducous or infrequently slowly deciduous, tube 1.2–3 mm, with ribs 2 or 3 with 1 rib on each side extending from internode rib to stipule lobe, sometimes also with narrow wings arising from base of petiole, apex with 2 or 3 incisions, marcescent, lobes 2(4) or 3(6), 0.2–1 mm, deltate to linear. *Inflorescences* cymose and few-flowered or reduced to 1 flower, terminal on axillary branches, puberulent to hirtellous or glabrescent, pendulous, sessile or peduncle to 7 mm; branched portion when present corymbiform, 0.5–2.5 \times 0.5–4.8 cm, lax, branched to 1 to 2 orders; bracts deltate or linear, 1–5 mm; bracteoles reduced; pedicels 2–6.5 mm. *Flowers* 5-merous, heterodistylous. *Long-styled flowers:*

calyx cup-shaped, 3–3.5 mm wide, outside glabrous or puberulent, sometimes with hair-ring inside, lobes 0.8–2 mm, triangular to linear; corolla white, clavate in bud, when open salverform, outside glabrous, tube 8–10 mm, 1.3–3.5 mm diam., inside villous at ca. middle, lobes 3–4 mm, triangular or ligulate, acute; anthers included, filaments inserted at ca. middle of corolla tube, ca. 0.1 mm; style 9–11 mm, glabrous or pubescent, stigma 0.5–1 mm. *Short-styled flowers*: similar to long styled except calyx 2.5–3.5 mm wide, lobes 1–2 mm; corolla tube 9.5–10.5 mm, 3.5–4.5 mm diam., lobes 3.5–4 mm; anthers shortly exerted, filaments 1.5–2 mm; style 5.5–6.5 mm, glabrous, stigma 1.5–2 mm. *Drupes* violet-black, globose to subglobose or didymous, 6–7 × 6–9 mm; pyrenes spherical to hemispherical, rugose, finely fissured, endosperm entire.

Distribution and habitat. This natural hybrid is known only from Sri Lanka. Here, it can be found in wet montane forests at elevations of 1400–1630 m.

Phenology. This natural hybrid has been collected with flowers April through August and has been collected with fruits, but the months of those collections were not noted.

Discussion. Although this has previously been treated as either a biological species or a synonymous name, *Gaertnera* × *gardneri* is here considered a natural hybrid between *G. walkeri* and *G. ternifolia*. Van Beusekom (1967) discussed the numerous morphologically irregular, apparently intermediate forms that link these two species and concluded that these are hybrids, but he did not formally recognize or circumscribe them. These hybrids can be recognized by their usually variable leaf arrangement, opposite and ternate on the same plants and often on the same stems, and their leaves and stipules of intermediate form. Whether these apparent hybrids are fertile is unknown. *Gaertnera* × *gardneri* is most often confused with *G. ternifolia*, but differs from that in the presence of both opposite and ternate leaves on a single stem, broader leaf blades, and salverform corollas.

Representative specimens examined. SRI LANKA. **Kandy:** Fairlawn Estate, Meriyakota, Peak Wilderness, *Jayasuriya 2841* (A, PDA). **Nuwara Eliya:** Peak Wilderness National Park, lower slopes of Adam's Peak (Sri Pada), *Malcomber 2768* (MO, PDA), *2769* (MO, PDA).

26. *Gaertnera globigera* Beusekom, *Blumea* 15: 379, fig. 8L. 1968. TYPE: Malaysia. Sarawak: Sibul Distr., path from Agricultural Station Rantau Panjang to Teku, *J. A. R. Anderson S. 9863* (holotype, SAR!). Figure 10A, B.

Trees, 2–6 m tall; branches flattened near stem apex, otherwise terete, when young glabrous or

puberulent or pilosulose with indumentum drying yellow to white, becoming glabrescent, 3–6 mm diam.; internodes 2.5–9 cm, smooth or with 2 longitudinal ribs. *Leaf* blades 15–25 × 2.5–5 cm, lanceolate, narrowly elliptic, or narrowly elliptic-lanceolate, apex acuminate or acute, base acute, drying coriaceous, glabrous, margin flat to thinly revolute; secondary veins prominulous abaxially, 6 to 10 pairs; domatia absent; petioles 15–30 mm. *Stipules* tubular, glabrous, drying chartaceous, persistent, tube 5–25 mm, with ribs 4, broadly winged, arising below petiole and extending to apex; apex with 1 or 2 incisions, persistent or sometimes fragmenting, lobes absent or 4, ca. 0.3 mm, deltate. *Inflorescences* congested-cymose, many-flowered, terminal on principal branches, glabrous to densely hirtellous, sessile or subsessile, subglobose, 1–3.5 × 1–3.5 cm, branched to 3 to 4 orders; bracts deltate, 0.5–2 mm; bracteoles reduced. *Flowers* 5-merous, subsessile, floral biology unknown. *Calyx* cup-shaped, 2.2–3.5 mm wide, outside pilosulose to glabrous, glabrous inside, truncate or lobes to 0.5 mm long, triangular; corolla, stamens, and stigmas unknown. *Drupes* unknown.

Distribution and habitat. This species grows in Southeast Asia, where it is known from Borneo in the Sarawak (Malaysia) sector. Here, it can be found in humid forests at an elevation of ca. 30 m.

Phenology. This species has been collected with flowers in June and has not been collected with fruits.

Discussion. Van Beusekom (1967) reported that *Gaertnera globigera* was found in both laterite forest and “kerangas” forests on white sand substrates in Bako National Park, Sarawak, Malaysia, on Borneo, based on a note on the type label. However, despite intensive documentation of the plants of this park, *G. globigera* has not been rediscovered there and overall is still only known from the type locality in Rantau Panjang Forest Reserve. Both collections seen of *G. globigera* lack mature flowers and fruit, but the species can be easily recognized by its relatively long, lanceolate to narrowly elliptic or narrowly lanceolate-elliptic leaves, its distinctive broadly winged stipules, and its subglobose inflorescences.

In the protologue, the collector of the type specimen was not listed but cited as “? collector, Sarawak 9863”; the name of this collector is J. A. R. Anderson based on records from SAR.

Additional specimen examined. MALAYSIA. **Sarawak:** Sibul Distr., 1.43 km ENE of Rantau Panjang Forest Reserve, *Malcomber 3038* (MO).

27. *Gaertnera grisea* Hook. f. ex C. B. Clarke, in Hook. f., *Fl. Brit. India* 4: 92. 1855. *Sykesia grisea* (C. B. Clarke) Kuntze, *Revis. Gen. Pl.* 2:

425. 1891. TYPE: Singapore, *N. Wallich 8389* (holotype, K!; isotypes, BM!, K!).

Trees or shrubs, 2–8 m tall; *branches* flattened near stem apex, otherwise terete to quadrangular, when young densely velutinous to pilosulose with indumentum drying pale yellow or gray-white becoming glabrescent, 3–5 mm diam.; internodes 2–10 cm, smooth. *Leaf* blades 9–30 × 4–12 cm, elliptic to oblanceolate or obovate, apex cuspidate or acuminate, base cuneate to obtuse, drying coriaceous, adaxially glabrous, abaxially densely velutinous to hirtellous with indumentum drying pale yellow or gray-white; secondary veins prominent abaxially, 7 to 11 pairs; domatia absent or present; petioles 7–18 mm. *Stipules* tubular, densely velutinous to pilosulose, drying chartaceous, persistent at least on distalmost nodes, tube 12–22 mm, with ribs 4, narrowly winged, arising below petiole and sometimes extending partway along sheath to lobes, apex entire, marcescent or fragmenting, lobes 4, 3–7 mm, deltate to linear. *Inflorescences* cymose, many-flowered, terminal on axillary branches, densely velutinous; peduncle 3.5–5.5 cm; branched portion corymbiform, 5–12.5 × 5–10 cm, lax to congested, branched to 3 to 4 orders; bracts narrowly deltate or linear, 4–6 mm; bracteoles reduced. *Flowers* 5-merous, unisexual, sessile. *Pistillate flowers*: calyx cup-shaped, 3–4 mm wide, outside densely puberulent to velutinous, with hairing inside, truncate or lobes to 0.5 mm, broadly triangular; corolla white, clavate in bud, when open salverform, outside densely puberulent, tube 5–7 mm, 1.5–2.5 mm diam., inside villous in upper third, lobes 2.5–4 mm, ligulate to ovate-oblong, acute; staminodia shortly exerted, filaments inserted in upper third of corolla tube, ca. 0.5 mm; style 6–6.5 mm, glabrous, stigma 2–2.5 mm. *Staminate flowers*: similar to pistillate except corolla tube 6.5–8.5 mm, 2–3 mm diam., lobes 3–4 mm; anthers shortly exerted, filaments 0.5–1 mm; style rudimentary. *Drapes* violet-black, globose or didymous, 5–7 × 5–7 mm; pyrenes spherical or hemispherical, rugose, finely fissured, endosperm entire.

Distribution and habitat. This species grows in Southeast Asia, where it is known from Peninsular Malaysia, Singapore, and the Riau Archipelago of Indonesia, near Singapore. Here, it is found in humid forests at elevations of 0–150 m.

Phenology. This species has been collected with flowers January through July and in November and December, and with fruits January through August.

Discussion. *Gaertnera grisea* is a locally common species. Most of the collections are from Bukit Timah

in Singapore. *Gaertnera grisea* can be recognized by its pale yellow or gray-white dried pubescence, tubular stipules with narrow stipule wings encircling the petiole that do not extend through to the top of the tube, and truncate to very shortly lobed calyx.

Additional specimens examined. INDONESIA. **Rioux** [Riau] **Archipelago**: Geliga, *Bünnemeyer 6512* (K, L, SING). MALAYSIA. **Negeri Sembilan**: Passir Panjang, *Ridley 13337* (BM, SING). SINGAPORE. Bukit Panjang, *Ridley 12528* (BM, K, SING).

28. *Gaertnera guillotii* Hochr., *Annuaire Conserv. Jard. Bot. Genève*, 11–12: 115. 1908, non *Gaertnera guillotii* (Hochr.) Bremek., 1963. TYPE: Madagascar. Toamasina: Distr. de Vatomandry près d'Analatsara, 3 Oct. 1903, *J. Guillot 36* (holotype, G!; isotype, K!). Figure 9H–N.

Trees, 2–8(–15) m tall; *branches* terete to quadrangular, when dry usually dark purple-black, glabrous, 1.5–4 mm diam.; internodes 0.5–8.5 cm, smooth. *Leaf* blades 1.7–13.2 × 0.7–4.6 cm, elliptic to oblanceolate or elliptic-oblong, apex rounded then shortly cuspidate to acuminate, base cuneate to obtuse, drying chartaceous, glabrous; secondary veins visible and flat to prominulous abaxially, 5 to 8(9) pairs; domatia present; petioles 5–9 mm. *Stipules* calyptrate, often becoming inflated prior to rupturing as tip elongates, glabrous outside, strigillose to sericeous inside, drying membranous, caducous, tube 11–49 mm, with ribs 4, rounded, arising above petiole and sometimes extending to top of sheath, wings under petiole base usually tardily developing after stipule tube falls and without connection to stipule ridges, apex with 1 incision, lobes 2, 1.2–3.7 mm, deltate. *Inflorescences* cymose, many-flowered, terminal on axillary branches, glabrous to puberulent or pilosulose with pubescence sometimes in lines; peduncle 0.5–2.2 cm; branched portion corymbiform, 0.6–7 × 0.8–6.2 cm, branched to 3 to 4 orders, lax to congested; bracts deltate or linear, 0.8–2 mm; bracteoles triangular to rounded, 0.5–1.5 mm, often lacinate; pedicels absent or up to 1.8 mm. *Flowers* 5-merous, heterodistylous. *Long-styled flowers*: calyx cup-shaped, 1.5–2.5 mm wide, glabrous, lobes 0.1–0.2 mm, triangular; corolla white, clavate in bud, when open salverform, outside glabrous, tube 3.5–4.5 mm, 1.5–3 mm diam., inside villous in upper third, lobes 2.5–3 mm, triangular or ligulate, acute; anthers included, filaments inserted in upper third of corolla tube, 0.3–0.7 mm; style 4.5–5.5 mm, glabrous, stigma 0.5–0.7 mm. *Short-styled flowers*: similar to long styled except corolla tube 1.3–3 mm diam., lobes 2–3 mm; anthers shortly exerted, filaments 2–2.5 mm; style 2.4–3 mm, stigma 0.8–1 mm. *Drapes* violet-black, subglobose or didymous, 4.5–5.5 × 4.5–

5.5 mm; pyrenes spherical or hemispherical, rugose, finely fissured, endosperm entire.

Distribution and habitat. This species grows in Madagascar, where it is known from Antsiranana, Fianarantsoa, Toamasina, and Toliara provinces. Here, it is widespread along the east coast of this island continent in humid forests at elevations of 0–25 m but occasionally up to elevations of 750 m; it usually can be found in littoral forests on white sand.

Phenology. This species has been collected with flowers May through December, and with fruits January through April and in November and December.

Discussion. *Gaertnera guillotii* is similar to *G. obovata*, but can be separated by its combination of elliptic to oblanceolate or elliptic-oblong leaves with flat margins, inflorescences with often pubescent axes, white flowers, and a habitat on white sand substrates and usually in littoral vegetation. The young branches usually drying dark purple-black are distinctive and helpful to recognize this species but are not exclusive to it; similarly colored dry branches are found in several other taxa, notably *G. obovata* var. *sphaerocarpha* (e.g., Malcomber et al. 2916, MO).

A group of specimens from the littoral forests in the northern part of Madagascar (Antsiranana and Toamasina) generally matches *Gaertnera guillotii*, but lacks domatia on the undersides of the leaves and has larger calyx lobes, to 1 mm long (e.g., Rabevohitra et al. 4195). These specimens are provisionally included here in *G. guillotii* pending further study.

Representative specimens examined. MADAGASCAR. **Antsiranana:** Near Antalaha, Imbert 94 (MO, P), Ranjokiny RN 8860 (MO, TAN), Unknown Collector RN 8898 (TAN); Sambava, Humbert 24378 (P). **Fianarantsoa:** Farafangana, Tohakandro, Capuron SF 23658 bis (MO, P, TEF); Mananjary, Geay 7719 (P). **Toamasina:** Ambila Lemaintso, Malcomber 2913 (MO, TEF), Ralarivohita SF 1103 (P, TAN, TEF); Ambodiriana, Cours 1943 (P, TAN); Mananara-Nord National Park, Raharimalala 317 (MO), Dumetz 858 (MO). **Toliara:** Betw. Antandrainiminty & Ambodisakona, Randraianasolo 288 (K, MO, TAN); Fort Dauphin, Decary 11066 (P), Humbert 5999 (P), Rabevohitra 2159 (MO, P, TAN), McPherson 14146 (MO, P, TAN, TEF).

29. *Gaertnera hirtiflora* Verdc., Kew Bull. 37: 535. 1983. TYPE: Mauritius. Plaines Wilhems Distr.: Macabé, 540 m, Aug. 1980, C. Puff 800825-1/10 (holotype, WU!; isotype, K!).

Trees, 5–7.5 m tall; branches flattened to terete, glabrous, 3–5 mm diam.; internodes 1.5–3.5 cm, smooth. Leaf blades 4–11 × 1.5–4.5 cm, elliptic or oblanceolate to obovate, apex obtuse and shortly cuspidate or acuminate, base acute to cuneate, drying

coriaceous or chartaceous, glabrous; secondary veins prominulous abaxially, 4 to 8 pairs; domatia present; petioles 2–12 mm. Stipules tubular, glabrous to densely puberulent, drying chartaceous, persistent at least on distalmost 3 to 6 nodes, tube 5–12 mm, with ribs 4, narrowly winged, arising below petiole, angling toward middle of interpetiolar side of tube then extending to lobes, apex entire, lobes 4, 4–6 mm, filiform; setae 4 to 10, linear, 3–7 mm. Inflorescences cymose, many-flowered, terminal, puberulent to glabrescent; peduncle 1–4 cm; branched portion corymbiform, 2.5–6 × 1.5–6 cm, branched to 2 to 4 orders, generally congested; bracts ovate, linear, or fused and trifold, 2–6 mm; bracteoles triangular to ovate, 1–2 mm; pedicel absent or to 3 mm. Flowers 5-merous, heterodistylous. Long-styled flowers: calyx cup-shaped or campanulate, 2.5–4 mm wide, puberulent outside, inside glabrous, lobes 1–2.5 mm, triangular to ovate; corolla white, clavate in bud, outside puberulent, tubular-salverform when open, externally densely puberulent to velutinous, tube ca. 13 mm, 1–1.5 mm diam., inside villous in throat, lobes narrowly elliptic-oblong, ca. 5.5 mm; stamens inserted in upper part of corolla tube, anthers subsessile, included or partially exerted; style ca. 13 mm, stigmas ca. 2 mm, exerted. Short-styled flowers: unknown. Drupes unknown.

Distribution and habitat. This species grows in Mauritius, where it is found in medium to tall wet evergreen forests (D. H. Lorence, pers. comm.) at elevations of 500–700 m.

Phenology. This species has been collected with flowers August through December, but has not been collected with fruits.

Discussion. *Gaertnera hirtiflora* is similar to both *G. edentata* and *G. psychotrioides*, but can be separated by its tubular stipules with four well-developed linear lobes and several smaller but similar setae and its densely puberulent corolla tubes. The fleshy, white, relatively long flowers were reported on the label of Lorence 1541 to have a fragrance similar to the cultivated gardenia; these were collected at midday (D. Lorence, pers. comm.), but the flowers with these characteristics of nocturnal Rubiaceae flowers may be nocturnal or crepuscular as well.

Representative specimens examined. MAURITIUS. Black River Gorge National Park, S. Malcomber 2937 (MO), 2934 (MO), Vaughan MAU 13042 (MAU); Plaine Champagne, Lorence 1541 (MO).

30. *Gaertnera hispida* Aug. DC., Bull. Herb. Boissier, sér. 2, 1: 585. 1901. TYPE: Madagascar. Toamasina: Maroa [Maroantsetra], A. Moc-

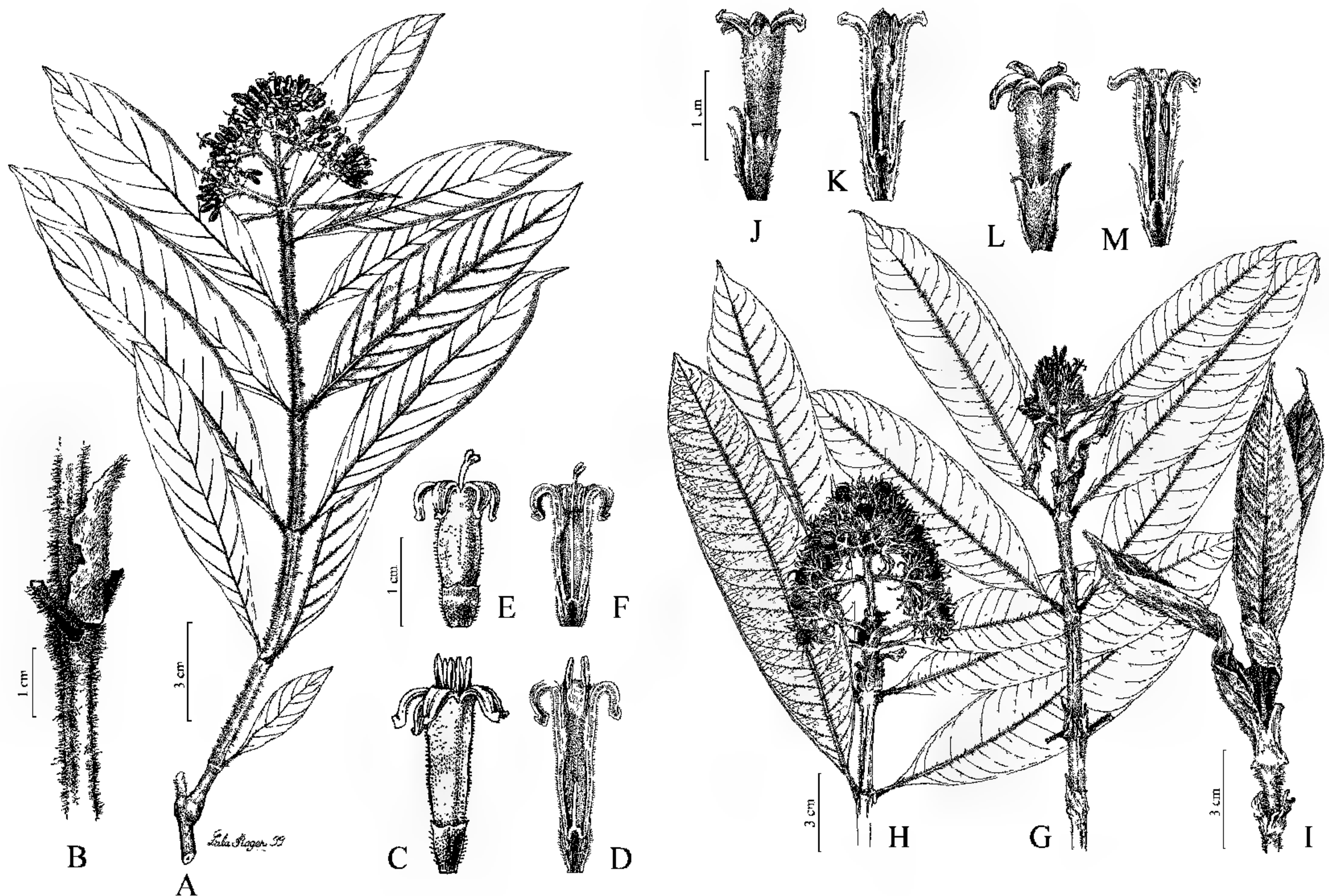

Figure 11. A–F. *Gaertnera hispida* Aug. DC. —A. Flowering branch. —B. Portion of stem with petiole bases and stipules. —C. Short-styled flower. —D. Short-styled flower in cross section. —E. Long-styled flower. —F. Long-styled flower in cross section. G–M. *Gaertnera phanerophlebia* Baker. —G. Flowering branch. —H. Fruiting branch. —I. Portion of stem with stipules and stem apex with young leaves. —J. Short-styled flower. —K. Short-styled flower in cross section. —L. Long-styled flower. —M. Long-styled flower in cross section. C–F to same 1-cm scale; G, H to same 3-cm scale; J–M to same 1-cm scale. A–F based on *Moise 11*; G, I–M based on *Moise 10*; H based on *Malcomber 2830*.

quercus 155 (lectotype, designated here, G-DC!).
Figure 11A–F.

Trees, 2.5–12 m tall; *branches* terete, hispid with indumentum drying red-brown to brown, 2–5 mm diam.; internodes 1.2–8.5 cm, smooth. *Leaf* blades 6.1–16.1 × 1.1–3.1 cm, narrowly elliptic to elliptic-oblong or oblanceolate, apex acute to shortly acuminate, base acute or cuneate, drying chartaceous, adaxially glabrous or sparsely hispid to hirsute on costa and sometimes secondary veins and lamina, abaxially hispid to hirsute with indumentum denser on veins and drying reddish brown to brown; secondary veins prominulous abaxially, 9 to 16 pairs; domatia absent; petioles 2–10 mm. *Stipules* calyprate, densely hispid to strigose, drying membranous, caducous, tube 11–32 mm, without ribs, apex with 1 incision, lobes 2 or 4, 0.5–2(–4) mm, deltate or linear. *Inflorescences* cymose, many-flowered, terminal on axillary branches, densely villous to villosulous or pilosulose, sessile or peduncle to 5 cm; branched portion corymbiform, 1.8–8.5 × 1.4–8.5 cm, branched to 3 to 5 orders, lax to rather congested; bracts linear to ligulate or deltate, 1.1–6 mm, sometimes glabrous above; bracteoles

reduced; pedicels absent or to 2.5 mm. *Flowers* 5-merous, heterodistylous. *Long-styled flowers*: calyx cup-shaped, 1.7–4 mm wide, puberulent outside, glabrous inside, truncate or lobes to 0.9(–1.5) mm, triangular; corolla white, clavate in bud, when open salverform, outside glabrous to puberulent, tube 8–9.5 mm, 2–3.5 mm diam., inside villous at ca. middle, lobes 2–3.5 mm, triangular or ligulate, acute; anthers included, filaments inserted in upper third of corolla tube, ca. 0.4 mm; style 9–11 mm, glabrous, stigma 0.7–2 mm. *Short-styled flowers*: similar to long styled except calyx 1.5–3.5 mm wide; corolla puberulent outside, tube 6.5–11 mm, 1.5–3 mm diam., lobes 1.5–4 mm; anthers shortly exerted, filaments 3–4.5 mm; style 3–6 mm, stigma 1.5–2.5 mm. *Drupes* violet-black, globose to subglobose or didymous, 8–14 × 7–14 mm; pyrenes spherical or hemispherical, rugose, finely fissured, endosperm entire.

Distribution and habitat. This species grows in Madagascar, where it has been found in the province of Toamasina in Mananara-Nord and Masoala National Parks. Here, it can be found in humid forests at elevations of 0–300 m.

Phenology. This species has been collected with flowers in October, and with fruits January through April and in December.

Discussion. *Gaertnera hispida* can be recognized by its calyprate stipules that dry membranous, its hispid indumentum drying reddish brown to brown, and its generally lax corymbiform inflorescence. This species is similar to *G. phanerophlebia*, which differs in its well-developed calyx lobes 2–5 mm long.

Two syntypes were cited in the protologue of *Gaertnera hispida*, A. Mocquerys 155 (G-DC!) and A. Mocquerys 167 (G-DC!). The former is selected here as lectotype because it is a more complete and exemplary specimen.

Representative specimens examined. MADAGASCAR. **Toamasina:** Mananara National Park, 6.4 km W of Antanambe, Malcomber 2897 (MO, TEF), Morat et al. 858 (P), 8613 (MO, P); Masoala National Park, Malcomber 2824 (MO, TEF), 2817 (MO, TEF), 2818 (MO, TEF), Schatz 3314 (K, MO, P, TAN), 3346 (K, MO, P, QRS, TAN).

31. *Gaertnera humblotii* Drake, Bull. Soc. Bot. France 45: 352. 1899. TYPE: Madagascar. NE Madagascar, H. Humblot 655 (holotype, P!; isotypes, MO!, P!, WU!).

Trees or shrubs, 2–10 m tall; *branches* flattened near stem apex, otherwise terete, glabrous, 1.5–4 mm diam.; internodes 1.5–7.5 cm, smooth. *Leaf* blades 4–16.5 × 1–5.5 cm, elliptic-lanceolate or oblanceolate to elliptic, apex cuspidate to acute, base attenuate or cuneate, drying coriaceous, glabrous; secondary veins barely visible and flat to prominulous abaxially, 7 to 10 pairs; domatia absent; petioles 3–20 mm. *Stipules* tubular, glabrous, drying chartaceous, deciduous or usually persistent on at least distalmost 2 to 5 nodes, tube 3–10 mm, with ribs 4, rounded to narrowly winged, arising below petiole and sometimes extending to lobes, apex entire, marcescent, lobes 4, 0.5–1.5 mm, filiform. *Inflorescences* cymose, many-flowered, terminal on axillary branches, glabrous or puberulent; peduncle 1.5–8.8 cm; branched portion corymbiform, 2.5–9(–14.5) × 3–11 cm, branched to 3 to 5 orders, lax to somewhat congested; bracts deltate to narrowly spatulate or trifid, 5–35 mm, white; bracteoles triangular, 1–2 mm, white; pedicels absent or up to 5 mm. *Flowers* 5-merous, heterodistylous. *Long-styled flowers:* calyx campanulate, 2–3 mm wide, glabrous, lobes unequal, 5–7 mm, narrowly spatulate to narrowly elliptic-oblong, white; corolla white, clavate in bud, when open infundibuliform to salverform, outside glabrous; tube 10–17 mm, 1.5–3 mm diam., inside villous in upper third, lobes 3.5–4 mm, ligulate to linear, acute or rounded; anthers included, filaments inserted in upper third of corolla tube, 0.2–1 mm; style 10–18 mm, glabrous, stigma

1.4–2 mm. *Short-styled flowers:* similar to long styled except calyx 2.2–3 mm wide, lobes 5–6 mm, linear; corolla tube 3–4.5 mm diam., lobes 3.7–5 mm; anthers shortly exerted, filaments 2–4 mm; style 5–7 mm, stigma 4–5 mm. *Drupe*s violet-black, subglobose or didymous, 6–8 × 6.5–8 mm; pyrenes spherical or hemispherical, ± rugose, finely fissured, endosperm entire.

Distribution and habitat. This species grows in Madagascar, where it is known from the province of Toamasina. Here, it is found in humid forests at elevations of 0–600 m.

Phenology. This species has been collected with flowers in February and with fruits February through April.

Discussion. *Gaertnera humblotii* is an attractive species with distinctive tubular stipules and relatively large, showy, white, mostly narrowly spatulate to narrowly elliptic-oblong inflorescence bracts and calyx lobes. It is similar in general aspect and many details to *G. raphaelii* Malcomber; see additional comments under that species. *Gaertnera humblotii* may hybridize with *G. phanerophlebia*; see comments under that species.

Representative specimens examined. MADAGASCAR. **Toamasina:** Masoala Peninsula, Schatz 2620 (MO, P, TAN); Brickavelle, Peak of Ambalarondra of Andrambolahykely, Andranampony, Cours 4509 (P, TAN); Marojejy Integral Reserve, Randrianasolo 320 (K, MO); Maroantsetra, Schatz 1875 (MO, P, TAN).

32. *Gaertnera ianthina* Malcomber, sp. nov. TYPE: Madagascar. Antsiranana: Marojejy Nature Reserve, near camp 2 on summit trail, 14°26'S, 49°45'E, 800–1000 m, 17 Sep. 1997, S. T. Malcomber 2773 (holotype, MO!; isotypes, A!, BR!, G!, K!, P!, PRE!, TEF!, WAG!). Figure 5G, H.

Haec species *Gaertnerae phanerophlebiae* Baker similis, sed ab ea caule in sectione transversali quadrangulari, indumento in sicco griseoalbo atque corolla pallide roseo-purpurea distinguitur.

Trees or shrubs, 3–10 m tall; *branches* terete to quadrangular, when young densely strigose to pilosulose with indumentum drying gray-white, becoming glabrescent, 1.5–5 mm diam.; internodes 2.5–4 cm, smooth. *Leaf* blades 6–20 × 2–7 cm, elliptic to elliptic-oblong or obovate, apex cuspidate or shortly acuminate, margins crisped, base obtuse to usually cuneate or acute, drying chartaceous, adaxially glabrous or densely pilosulose on costa and sometimes secondary veins, abaxially strigose or hispidulous to hispid on principal veins or throughout with indumentum drying gray-white; secondary veins prominu-

lous abaxially, (8 to)14 to 20 pairs; domatia absent; petioles 4–9 mm, furrowed and with 2 lateral ridges. *Stipules* calyptrate, densely pilosulose to villosulous, drying membranous, caducous, tube 7–40 mm, with ribs 4, narrowly winged, arising beneath petiole and sometimes extending to lobes, apex with 1 or 2 incisions, lobes 4, 2–3 mm, deltate or linear. *Inflorescences* cymose, many-flowered, terminal on principal and/or axillary branches, villous or pilosulose to strigose or glabrous, sessile or peduncle to 4 cm; branched portion corymbiform, 2.5–6(–8) × 2–7(–9) cm, branched to 3 to 4 orders, lax to congested; bracts ligulate, linear, or trifid, 2–30 mm; bracteoles ligulate, 0.1–2 mm; pedicels absent or to 2.5 mm. *Flowers* 5-merous, heterodistylous. *Long-styled flowers*: calyx cup-shaped, 1.5–2.5 mm wide, outside glabrous or strigillose, with hair-ring inside, lobes 0.5–2.5 mm, triangular, ciliate; corolla pale pink to purple, clavate in bud, when open salverform, outside glabrous, tube 7–9 mm, 2–2.5 mm diam., inside villous in upper third, lobes 3–4 mm, triangular to ligulate, acute; anthers included, filaments inserted in upper third of corolla tube, ca. 0.4 mm; style 7.5–8 mm, glabrous, stigmas 0.8–1 mm. *Short-styled flowers*: similar to long styled except lobes linear; corolla tube 9–10 mm, 1.5–3 mm diam.; anthers shortly exerted, filaments 0.8–1 mm; style 5–6 mm, stigmas 1–1.5 mm. *Drupes* violet-black or blue, globose or didymous, 6–7.5 × 7–10 mm; pyrenes spherical or hemispherical, faintly rugose, deeply fissured, endosperm entire.

Distribution and habitat. This species grows in northern Madagascar, where it is known from the provinces of Antsiranana and Mahajanga. Here, it grows near Manongarivo, Tsaratanana, and Marojejy in humid forests at elevations of 300–2000 m.

Phenology. This species has been collected with flowers January through May and in December, and with fruits January through June and in November and December.

Discussion. *Gaertnera ianthina* is similar in general aspect to some plants of *G. phanerophlebia*, but differs in its generally quadrangular stems, indumentum drying grayish white, generally lax inflorescences, pink to purple flowers, and shorter calyx lobes.

Paratypes. MADAGASCAR. **Antsiranana:** Andapa, *Christophe RN 8044* (P, TAN); Andapa, Ambodiharina, *Cours 3615* (P, TAN); Andapa, Lokoho, Ankobahina Peak, *Humbert 22024* (P), *21997* (P), *22045* (P); Andapa, Marovato, Antsahamarotoko, *Unknown Collector SF 21632* (TEF); Anjanaharibe Massif, Andramonta, Lokoho Basin, *Humbert 24504* (P); Anjanaharibe-Sud Nature Reserve, *Lewis 1318* (MO, P, TAN); Ankaizina, *Decary 1949* (P); Lokoho, near Ambalavoniho, *Humbert 22796* (P), *22817* (P); Manongarivo Nature Reserve, *Perrier de la Bâthie 3836* (P), *Malcomber*

2710 (MO, P, TAN), *Miller & Lowry 4050* (MO), *Nicoll 616* (MO, P, TAN), *Miller 4189* (MO, P), *Humbert 23106* (P), *Lewis 1253* (K, MO, P, TAN), *Malcomber 2795* (MO), *Miller & Randrianasolo 4667* (MO), *Humbert 22429* (P); Massif du Tsaratanana, haut bassin de la Maevarano, crete dans le bassin superieur du ruisseau de Befosa, *Capuron SF 24978* (P, TEF); Sambava, *Zamanivato RN 8252* (P, TAN); Tsaratanana Nature Reserve, *Unknown Collector RN 4719* (P, TAN). **Mahajanga:** Tsaratanana Massif, Magindrano up S ridge of Mayomokotro, *Gentry 11575* (TAN).

33. *Gaertnera inflexa* Baill., *Adansonia* 12: 237. 1879. TYPE: Madagascar. Toamasina: S Mariam, Tafondrou, Jan. 1848, *L.-H. Boivin 1778* (lectotype, designated here, P!; isotype, G!). Figure 8F–L.

Psychotria guillotii Hochr., *Annuaire Conserv. Jard. Bot. Genève* 11–12: 111. 1908. *Gaertnera guillotii* (Hochr.) Bremek., *Verh. Kon. Ned. Akad. Wetensch., Afd. Naturk., section 2*, 54: 148. 1963, hom. illeg., non *G. guillotii* Hochr., 1908. TYPE: Madagascar. Toamasina: Vatomaniry, 2 Oct. 1908, *J. Guillot 27* (holotype, G!; isotype, K!).

Trees, 1–6 m tall; *branches* flattened to terete, glabrous, 1.5–5.5 mm diam.; internodes 1.7–10.5 cm, smooth. *Leaf* blades 4.5–24 × 1.2–8 cm, narrowly elliptic, elliptic, or oblanceolate, apex acuminate, base acute or cuneate, drying chartaceous, glabrous; secondary veins prominulous abaxially, 7 to 13 pairs; domatia absent; petioles 4–55 mm. *Stipules* tubular, glabrous, drying chartaceous or membranous, caducous or sometimes persistent on distalmost 1 to 3 nodes, tube 2.3–4.5 mm, with ribs 4, narrowly winged, arising below or sometimes above petiole, often angling to connect in middle of interpetiolar side, then diverging and extending to lobes, apex entire, marcescent, lobes 4, 0.5–11 mm, deltate or filiform. *Inflorescences* cymose, several- to many-flowered, terminal on axillary and/or supra-axillary branches, pendulous, glabrous or puberulent; peduncle 1.5–6 cm; branched portion narrowly cylindrical or narrowly pyramidal, 3.5–7 × 1.1–3(–6) cm, branched to 2 to 3 orders, lax; bracts deltate to linear, 1–14 mm; bracteoles triangular to ligulate, 0.5–1 mm. *Supra-axillary branches* pendulous, up to 40 cm long, 0.8–1.4 mm diam., glabrous; leaves 2–10 × 0.3–2.5 cm, narrowly elliptic or linear, base attenuate; secondary veins 3 to 9 pairs; petiole 4–12 mm. *Flowers* 4-merous, heterodistylous, subsessile. *Long-styled flowers*: calyx cup-shaped, 1.2–1.5 mm wide, outside glabrous or puberulent, glabrous inside, truncate or lobes to 0.3 mm, triangular; corolla white, clavate in bud, when open salverform, outside glabrous, tube 3–3.5 mm, 0.9–2 mm diam., inside villous in upper third, lobes 1.5–2 mm, triangular or ligulate, acute; anthers included, filaments inserted at ca. middle of corolla tube, ca. 0.5 mm; style 2.5–3 mm, glabrous,

stigma 0.5–0.7 mm. *Short-styled flowers*: similar to long styled except calyx 1–1.5 mm wide; corolla tube 3.5–4.5 mm, 1–2.5 mm diam., inside villous at ca. middle, lobes 1.5–2.5 mm; anthers included, filaments inserted in upper third of corolla tube, 1.5–2 mm; style 0.8–1.3 mm, stigma 0.8–1.3 mm. *Drupes* violet-black, subglobose or didymous, 6–6.5 × 5–7 mm; pyrenes spherical to hemispherical, rugose, finely fissured, endosperm entire.

Distribution and habitat. This species grows in Madagascar, where it is known from the provinces of Antsiranana and Toamasina. Here, it can be found in humid forests at elevations of 150–500 m.

Phenology. This species has been collected with flowers July through November and with fruits February through March.

Discussion. With narrowly cylindrical or pyramidal inflorescences often borne at the apex of long, pendent supra-axillary branches, *Gaertnera inflexa* is a distinctive species within Madagascar. It is similar to *G. diversifolia* of southeastern Asia, but differs from that in its bisexual 4-merous flowers. *Gaertnera inflexa* is also similar to *G. cardiocarpa*; see comments under that species.

The plants included in this species here exhibit considerable variation in length of the stipule lobes and inflorescence shape and size. Collections from the southern part of its range (e.g., *Guillot 27*, type of *Psychotria guillotii*) might be better considered a distinct subspecies or species, but these populations are provisionally included here in *Gaertnera inflexa* due to the current paucity of available collections.

Two syntypes were cited in the protologue of *Gaertnera inflexa*, *L.-H. Boivin 1778* (G!, P!) and *J. M. C. Richard 5* (Madagascar, Bay of Antongil, 1837, P!). The former is selected as lectotype here because it has a duplicate at another herbarium. The duplicate at P is chosen as the lectotype because it is deposited in the herbarium where the author of the name worked.

Representative specimens examined. MADAGASCAR. **Antsiranana:** Antalaha, *Rakotozafy 521* (TAN). **Toamasina:** Ivontaka, *Decary 111* (P); Mananara National Park, *Malcomber 2886* (MO), *2900* (MO, TEF), *2901* (MO, TEF), *Rafamantanantsoa OUEM 31* (K, MO); Mananara-Nord, *Raharimalala 1502* (P), *2151* (P); Nosy Mangabe, *Schatz 1661* (MO); Sahavolamena, Soanierana-Ivongo, *Unknown Collector SF 11060* (MO, TEF), *Capuron SF 23805* (P, TEF).

34. *Gaertnera junghuhniana* Miq., *Fl. Ned. Ind.* 2: 383. 1856. *Sykesia junghuhniana* (Miq.) Kuntze, *Revis. Gen. Pl.* 2: 425. 1891. *Gaertnera vaginans* subsp. *junghuhniana* (Miq.) Beusekom, *Blumea* 15: 388. 1967 [1968]. TYPE: Indonesia. Sumatra, *F. W. Junghuhn s.n.* (lectotype, designated by van Beusekom, 1967 [1968]: 385, L!; isotype,

U not seen). [SYNTYPE: *J. E. Teijsmann s.n.* (syntype, BO not seen, GH!)] Figure 6A–F.

Gaertnera zollingeriana Miq., *Fl. Ned. Ind.* 2: 382. 1857. *Sykesia zollingeriana* (Miq.) Kuntze, *Revis. Gen. Pl.* 2: 426. 1891. TYPE: Indonesia. Java, *H. Zollinger 3051* (holotype, G!; isotypes, A!, G!).

Gaertnera oxyphylla Benth., *J. Proc. Linn. Soc., Bot.* 1: 112. 1857, non *Gaertnera oxyphylla* Drake, 1899. *Psychotria oxyphylla* Wall., *Cat. n.* 8374. 1847, nom. nud. *Gaertnera koenigii* var. *oxyphylla* (Benth.) C. B. Clarke, in *Hook. f., Fl. Brit. India* 4: 91. 1883. *Sykesia oxyphylla* (Benth.) Kuntze, *Revis. Gen. Pl.* 2: 425. 1891. *Gaertnera acuminata* var. *oxyphylla* (Benth.) Ridl., *Fl. Malay. Penin.* 2: 428. 1923. TYPE: Singapore, *N. Wallich 8374* (holotype, K!; isotypes, BM!, K!).

Gaertnera acuminata Benth., *J. Proc. Linn. Soc., Bot.* 1: 112. 1857. *Sykesia acuminata* (Benth.) Kuntze, *Revis. Gen. Pl.* 2: 425. 1891. TYPE: Singapore, *N. Wallich 8342* (holotype, K!; isotypes, BM!, K!).

Gaertnera oxyphylla var. *angustifolia* Ridl., *Fl. Malay. Penin.* 2: 428. 1932. TYPE: Malaysia. Kedah: Kedah Peak, Dec. 1915, *C. B. Kloss & H. C. Robinson 5963* (holotype, SING!).

Gaertnera brevistylis Ridl., *Bull. Misc. Inform. Kew* 1934: 124. 1934. TYPE: Malaysia. Sabah: Sandakan, *C. V. Creagh s.n.* (holotype, K!; isotype, K!).

Gaertnera taiensis Kerr, *Bull. Misc. Inform. Kew* 1940: 180. 1940. TYPE: Thailand. Trang: Kao Soi Dao, 300 m, *A. Kerr 19137* (holotype, K!; isotypes, BM!, L!).

Trees or shrubs, 1–10(–15) m tall; *branches* terete to flattened or quadrangular, glabrous to puberulent, 1–6 mm diam.; internodes (0.5–)1.3–7(–10) cm, smooth. *Leaf* blades 3–24 × (0.7–)1–9.5 cm, lanceolate to narrowly lanceolate, elliptic-oblong, elliptic, or oblanceolate, apex acuminate or cuspidate, base cuneate to acute (rounded), drying chartaceous, adaxially glabrous, abaxially glabrous to puberulent or pilosulose on principal veins with indumentum drying gray-white; secondary veins prominulous abaxially, 3 to 9(to 11) pairs; domatia absent or present; petioles 2–25 mm. *Stipules* tubular, glabrous to puberulent, drying chartaceous, caducous or fragmenting, tube (3–)8–23 mm, with ribs none or 4, narrowly to broadly winged, arising below petiole and sometimes extending to lobes, apex entire or with 1 or 2 incisions, marcescent, lobes 4, 1.5–7 mm long, deltate. *Inflorescences* cymose, several- to many-flowered, terminal on axillary branches, glabrous to densely puberulent or pilosulose, sessile or peduncle to 6.5 cm; branched portion corymbiform to pyramidal, 1.5–15(–18) × 1.5–17(–22) cm, lax, branched to 2 to 6 orders; bracts deltate or trifid, 3–10 mm; bracteoles reduced; pedicels absent or to 3.5 mm. *Flowers* 5-merous, unisexual. *Pistillate flowers*: calyx cup-shaped, 2–3 mm wide, outside glabrous or puberulent, with hair-ring inside, truncate or lobes to 0.4(–0.7) mm, triangular; corolla pale green or

white, clavate in bud, when open salverform, outside glabrous or puberulent, tube 2.5–5 mm, 1.5–2.2 mm diam., inside villous in upper third, lobes 1.5–3 mm, triangular to ligulate, acute; staminodia included, filaments inserted in upper third of corolla tube, ca. 0.2 mm; style 3–6 mm, glabrous, stigma 2–2.5 mm. *Staminate flowers*: similar to pistillate except corolla tube 2–5 mm, 1.8–2.5 mm diam.; anthers shortly exerted, filaments 0.5–2 mm long; pistillode with style portion absent or ca. 1 mm, glabrous, stigma absent or ca. 0.5 mm. *Drapes* violet-black, didymous or globose, 5–7 × 5–8 mm; pyrenes spherical or hemispherical, rugose, finely fissured, endosperm entire.

Distribution and habitat. This species grows in southeastern Asia, where it is known from Thailand, Peninsular Malaysia, Sumatra (part of Indonesia), Borneo in the Brunei, Kalimantan (Indonesia), and Sarawak (Malaysia) sectors, and Sulawesi (part of Indonesia). Here, it is found in humid forests at elevations of 0–1500 m.

Phenology. This species has been collected with flowers and fruits throughout the year.

Discussion. This species belongs to the *Gaertnera vaginans* complex; see also the discussion of that group for related species and their distinctions. This species was included by van Beusekom (1967) in his broad circumscription of *G. vaginans*, as *G. vaginans* subsp. *junghuhniana*, but these species are considered separate here as discussed in the introduction. Some specimens included by him in *G. vaginans* subsp. *junghuhniana* are treated here in *G. alstonii*, *G. aphanodioica*, *G. belumutensis*, *G. capitulata*, *G. kochummenii*, *G. ramosa*, and *G. sralensis*. *Gaertnera junghuhniana* as circumscribed here can be distinguished by its tubular stipules that dry chartaceous and closely surround the stem, its several- to many-flowered cymes, and its pale green or white flowers with either a well-developed androecium and relictual gynoecium (staminate) or well-developed gynoecium and relictual androecium (pistillate).

Representative specimens examined. BRUNEI [DARUS-SALAM]. **Belait**: Badas Reserve, *Malcomber 3001* (MO), *3002* (MO), *3003* (MO), *3004* (MO), *3005* (MO), *3006* (MO). **Brunei-Muara**: Rimba Kumpul Meragang, *Suhaili Hj. Zinin BRUN 15022* (SAN). **Temburong**: Wong Ngaun Gorge, *Wong 1724* (A, BRUN, KEP, L, SAR, SAN, SING). INDONESIA. **Borneo**. Kalimantan: Sg. Sebakis, Bulungan, *Kostermans 9252* (K, L, SING). Kalimantan Timur [East Kalimantan]: Wanariset-Handil II, *Van Balgooy 6062* (K); Malili, Larona, 2°40'S, 121°10'E, *Meijer 11241* (L). **Celebes**. Sulawesi: betw. Soroaka & Wawondula, *Van Balgooy 4052* (A, K, L). **Sumatra**. Aceh: Asahan, Poelock, *Rahmat Si Boeea 5722* (A, G, K, L). Bangka: Lobok-besar, *Kostermans 238* (A, BM, K, KEP, L, SING). Riau: Bukit

Karampal, 0°46'S, 102°32'E, 100 m, *Burley 1157* (A, E, K, KEP, L, SING). Riouw [Riau] Archipelago: Batang Belobang, 40 m, *Bünnemeyer 7686* (L). **Selantin [South Sumatra]**: Palembang, Bigin Telok, *Forbes 3214* (BM, K, L, SING, WU). MALAYSIA. **Sabah**: Sandakan, Sepilok Reserve 5, *Nawas A. 834* (A, K, KEP, SING). **Sarawak**: Bako Park, *Ashton 17970* (K, L, SAR), *Malcomber 2028* (MO); Lambir Park, *Rena George S. 40507* (E, K, KEP, L, SAN, SAR). **Selangor**: Ulu Gombak Reserve, *Kochummen FRI 32515* (A, K, KEP, L, SAN). **Terengganu**: Bukit Bauk, *Malcomber 2027* (MO). THAILAND. **Trang**: Kao Soi Dao, *Kerr 19137* (K, L).

35. *Gaertnera kochummenii* Malcomber, sp. nov.

TYPE: Malaysia. Terengganu: 10th Mile, Dungan-Bukit Besi Rd., Compt. 12, Bukit Bauak Forest Reserve, 4°46'N, 103°10'E, 18 June 1967, *K. M. Kochummen FRI 2387* (holotype, KEP!; isotype, L!).

Haec species *Gaertnerae junghuhnianae* Miq. similis, sed ab ea planta in sicco aurantiaca, inflorescentia congesta capituliformi atque lobulis calycinis bene evolutis usque ad 3.5 mm longis distinguitur.

Shrubs, to 1 m tall; plants drying with orange cast; branches terete, when young puberulent with indumentum drying brown, becoming glabrescent, 2–3 mm diam.; internodes 3.2–7 cm, smooth. *Leaf* blades 6.5–17 × 1.5–5 cm, (narrowly) elliptic, apex acuminate, base attenuate, drying chartaceous, adaxially glabrous, abaxially puberulent with indumentum drying reddish to orange; secondary veins distinct abaxially, 7 to 9 pairs; domatia absent; petioles 3–5 mm. *Stipules* tubular, puberulent, drying chartaceous, tube 6–12 mm, with ribs 4, narrowly winged, arising below petiole and extending to lobes; apex with 2 incisions, marcescent, lobes 4, ca. 5 mm, deltate to linear. *Inflorescences* congested-cymose, many-flowered, terminal on axillary branches, pilosulose, sessile, subglobose, 1.5–2.5 × 2–3 cm, congested, branched to 1 to 2 orders; bracts deltate, 0.5–2 mm, sometimes glabrous; bracteoles reduced; pedicels absent or to 2 mm. *Flowers* 5-merous, floral biology unknown. *Calyx* campanulate, 2.5–3.5 mm wide, outside puberulent or pubescent, glabrous inside, lobes 1–3.5 mm, ovate; corolla, stamens, and stigmas unknown. *Immature drupes* globose or subglobose, 5–7 × 5–7 mm.

Distribution and habitat. This species grows in southeastern Asia, where it has been found in Peninsular Malaysia. The habitat and elevations where it grows have not been recorded.

Phenology. This species has been collected with flower buds in June; it has not been collected with mature flowers or fruits.

Discussion. This is a poorly known but distinctive species. *Gaertnera kochummenii* can be recognized by

the distinctive orange color of dried specimens; its pubescent branches, leaves, and stipules; its congested subglobose inflorescence; and its well-developed calyx lobes. The mature flowers and fruits are unknown. This species is named in honor of K. M. Kochummen (1931–1999), who collected the type specimen and produced many important contributions to Malesian botany. This species belongs to the *G. vaginans* complex; see also the discussion of that group for related species and their distinctions.

36. *Gaertnera letouzeyi* Malcomber, sp. nov.
TYPE: Cameroon. Betw. Tabo & Akoumayip River, 20 km W of Mamfe, 2 June 1975, R. Letouzey 13702 (holotype, MO!; isotypes, BR!, K!, MO!, P!, WAG!).

Haec species *Gaertnerae paniculatae* Benth. similis, sed ab ea foliis oblongo-ovatis atque stipulis manifeste quadrangularibus apice semel fissis in quoque latere tubi ac sub petiolo alis duabus longitudinalibus prominentibus munitis distinguitur.

Shrubs, 4–5 m tall; *branches* flattened near stem apex, otherwise terete to subquadrangular, when young branches glabrous or puberulent with indumentum drying yellow, becoming glabrescent, 5–9 mm diam.; internodes 4.5–16 cm, smooth. *Leaf* blades 16–33 × 7.5–13.5 cm, elliptic-oblong to ovate, apex rounded then abruptly shortly cuspidate or acuminate, base cuneate or obtuse, drying coriaceous or chartaceous, glabrous; secondary veins prominulous abaxially, 7 to 12 pairs; domatia absent; petioles 10–45 mm. *Stipules* tubular, glabrous or puberulent, drying chartaceous, persistent on distal-most nodes or fragmenting, tube 30–45 mm, with ribs 4, narrowly winged, arising below petiole and extending to lobes, apex with 1 incision, lobes 2, 1–7 mm, deltate. *Inflorescences* cymose, many-flowered, terminal on principal and/or axillary branches, densely pilosulose to glabrous; peduncle 2.5–13.5 cm; branched portion corymbiform, 7–23 × 6.5–22 cm, branched to 3 to 5 orders, lax; bracts deltate or trifid, 3–10 mm; bracteoles reduced; pedicels absent or up to 3.5 mm. *Flowers* 5-merous, floral biology unknown. *Calyx* cup-shaped, 2.5–3.5 mm wide, pale pinkish green, outside glabrous or puberulent, with hair-ring inside, lobes 0.3–2 mm, triangular to oblong or rounded; corolla in bud white, clavate and densely puberulent outside with tube to 5 mm and lobes to 3 mm, mature corollas, stamens, and stigmas unknown. *Drupes* violet-black, globose or subglobose or didymous, 6–9 × 6–9 mm; pyrenes spherical or hemispherical, rugose, finely fissured or with pale brown striations, endosperm entire.

Distribution and habitat. This species grows in Central Africa, where it has been found in Cameroon.

Here, it is found in lowland humid forests, but the elevation where it grows has not been noted.

Phenology. This species has been collected with flowers in May and June and with fruits in July.

Discussion. *Gaertnera letouzeyi* is similar to *G. lowryi* of Madagascar, but differs in its elliptic-oblong to ovate leaves with seven to 12 pairs of secondary veins and its pale pinkish green calyx tubes. This species is named in honor of the botanist René Letouzey (1918–1989), who collected the type specimen in addition to numerous other notable plants from Cameroon.

Paratypes. CAMEROON. Akwaya-Mamfe rd., betw. Nyang & Mabeme river, 20 km NNE of Mamfe, 31 July 1975, Letouzey 14153 (P); Korup National Park, Kenfack 763 (MO).

37. *Gaertnera leucothyrsa* (K. Krause) E. M. A. Petit, Bull. Jard. Bot. État Bruxelles 32: 186. 1962. Basionym: *Psychotria leucothyrsa* K. Krause, Bot. Jahrb. Syst. 57: 47. 1920. TYPE: Belgian Congo [Democratic Republic of the Congo]. Orientale: Betw. Yangambi & Patabongo, May 1908, G. W. J. Mildbraed 3287 (lectotype, designated by Petit, 1962: 186, HBG not seen; isotypes, B†, HB not seen). [SYNTYPE: G. W. J. Mildbraed 3206 (B†).]

Gaertnera parvipaniculata E. M. A. Petit, Bull. Jard. Bot. État Bruxelles 29: 52. 1959. TYPE: Belgian Congo [Democratic Republic of the Congo]. Orientale: Yangambi, ca. 470 m, 25 June 1938, J. Louis 9979 (holotype, BR!).

Trees or shrubs, 0.8–2.5 m tall; *branches* terete, glabrous, 1.5–5 mm diam.; internodes 0.4–6.5 cm, smooth. *Leaf* blades 3.2–17 × 1.3–5.5 cm, elliptic to oblanceolate or obovate, apex cuspidate or acuminate, base attenuate or cuneate, drying chartaceous, glabrous; secondary veins prominulous abaxially, 4 to 7 pairs; domatia absent; petioles 5–10 mm. *Stipules* tubular, glabrous, drying membranous, caducous, tube 10–30 mm, with ribs 4, narrowly winged, arising below petiole and sometimes extending to lobes, apex with 1 incision, marcescent, lobes 4, 1–4 mm, linear to filiform. *Inflorescences* cymose, several- to many-flowered, on principal and/or axillary branches, pilosulose or puberulent, sessile or peduncle to 4 cm; branched portion subglobose or corymbiform 0.9–5 × 1–4 cm, branched to 1 to 4 orders, congested; bracts linear to lanceolate, 1–6.5 mm, glabrous; bracteoles reduced; pedicels absent or to 1.5 mm. *Flowers* 5-merous, heterodistylous. *Long-styled flowers:* calyx cup-shaped, 1.5–3 mm wide, glabrous or puberulent outside, with hair-ring inside, lobes 1–4 mm, linear to triangular or lanceolate; corolla white, clavate in bud, when open infundibu-

liform or salverform, outside glabrous, tube 3.5–5.5 mm, 1.5–2.5 mm diam., inside villous in upper third, lobes 2.5–4 mm, lanceolate or linear, obtuse or rounded; anthers included, filaments inserted in upper third of corolla tube, ca. 0.3 mm; style 4.5–5.5 mm, glabrous below and pubescent near apex, stigmas 0.5–1.2 mm. *Short-styled flowers*: similar to long styled except corolla tube 4–5 mm, 2.2–2.6 mm diam., lobes 3–4 mm, ligulate or ovate-oblong, acute; anthers fully exerted, filaments 1.5–2.5 mm; style 2.8–3.2 mm, glabrous, stigmas 1–1.4 mm. *Drupes* violet-black, globose or subglobose, 6–10 × 6–10 mm; pyrenes spherical or hemispherical, smooth, endosperm entire.

Distribution and habitat. This species grows in Central Africa, where it has been collected in the Democratic Republic of the Congo and Gabon. Here, it is found in humid forests at elevations of 470–1150 m.

Phenology. This species has been collected with flowers June through October and with fruits January through April and July through December.

Discussion. *Gaertnera leucothyrsa* is similar to and may be confused with *G. bieleri* in Central Africa, but *G. leucothyrsa* differs from that species in its glabrous stems and stipules and its caducous stipules with one incision. *Gaertnera leucothyrsa* is also similar in general aspect to *G. longivaginalis* var. *bracteata*; see comments under that species.

As noted by Petit (1959b), the stipules of this species are distinctive but rarely observed on herbarium collections. Petit described *Gaertnera parvipaniculata* in his review of African *Gaertnera* (1959a) and then discovered an older name for this species during a review of African *Psychotria* (Petit, 1962). He selected as lectotype the only specimen he located of Krause's original materials.

Additional specimens examined. DEMOCRATIC REPUBLIC OF THE CONGO. Befale, Ifale River, *Evrard* 2893 (BR, P, WAG); Epulu, Mambasa, Ituri Forest, *Hart* 319 (BR), *Liengola* 157 (WAG); Iwama (Monkoto Territory), *Evrard* 2827 (BR, K, WAG); Kole (Sankuru), *Lebrun* 6332 (BR, K), 6414 (BR, FHO); Okoka Village (Lodja-Sankuru Territory), *Germain* 7551 (BR); Yangambi, *J. Louis* 2252 (BR), 2305 (BM, BR), 11211 (BR, MO), 11586 (BR). GABON. Ngoumié: Chaillu Massif, *A. M. Louis et al.* 909 (K, WAG).

38. *Gaertnera liberiensis* E. M. A. Petit, Bull. Jard. Bot. État Bruxelles 29: 40. 1959, nom. nov. *Gaertnera salicifolia* Hutch. & Gillett, Fl. W. Trop. Afr. 2: 21. 1931, hom. illeg., non *Gaertnera salicifolia* C. H. Wright ex Baker, 1903. TYPE: Liberia. Monrovia, Dukwai River, 1928, *G. P. Cooper* 277 (holotype, K!; isotypes, A!, BM!, FHO!).

Trees, up to 7 m tall; bark smooth; *branches* terete, puberulent with indumentum drying yellow or gray-white, 1–2 mm diam.; internodes 2.5–5.2 cm, smooth. *Leaf* blades 6–12 × 1.5–3 cm, elliptic to oblong or lanceolate, apex acuminate, base cuneate, drying chartaceous, adaxially glabrous, abaxially glabrous except pubescent on principal veins with indumentum drying reddish brown to brown; secondary veins distinct abaxially, 4 to 7 pairs; domatia present; petioles 2–8 mm. *Stipules* tubular, pubescent, drying chartaceous, caducous, tube 7–10 mm, with ribs 4, narrowly winged, arising beneath petiole and extending to the apex, apex entire, marcescent, lobes 4, ca. 9 mm, linear to filiform, setae numerous, 1–9 mm. *Inflorescences* cymose, many-flowered, terminal on principal and/or axillary branches, puberulent; peduncle 2–3.5 cm; branched portion narrowly pyramidal, 1.8–5 × 1.2–3 cm, lax to congested, branched to 3 or 4 orders; bracts deltate or trifid, 3–8 mm, sometimes glabrous; bracteoles reduced; pedicels absent or to 0.5 mm. *Flowers* 5-merous, presumably heterodistylous. *Calyx* cup-shaped, 1–2 mm wide, outside puberulent, glabrous inside, truncate or lobes to 0.3 mm, triangular; corolla in bud white, clavate and glabrous outside, mature corollas, stamens, and stigmas unknown. *Drupes* unknown.

Distribution and habitat. This species grows in West Africa, where it has been collected in Liberia. The habitat and elevations where it grows have not been recorded.

Phenology. This species has been collected with flowers, but the collection months have not been recorded; it has not been collected with fruits.

Discussion. *Gaertnera liberiensis* is so far only known from the type specimen. It is similar to *G. eketensis*, but *G. liberiensis* lacks the diagnostic longitudinally striated or fissured bark of *G. eketensis* and has pubescent rather than glabrous stipules and a pyramidal rather than corymbiform inflorescence. Although Hutchinson and Gillett later provided a Latin diagnosis for their name *G. salicifolia* (Bull. Misc. Inform. Kew 1937: 62), this name was validly published in their 1931 work with an English diagnosis; the ICBN requirement (McNeil et al., 2006) for a Latin diagnosis only applies to names published during or after 1935.

39. *Gaertnera longifolia* Bojer, Hortus Maurit. 216. 1837. *Sykesia longifolia* (Bojer) Kuntze, Revis. Gen. Pl. 1: 425. 1891. TYPE: Mauritius. Nouvelle Découverte and Quartier Militaire, *W. Bojer* s.n. (holotype, P not located; isotype, W!).

Gaertnera longifolia var. *pubescens* Verdc., Kew Bull. 37: 542. 1983, syn. nov. TYPE: Mauritius. Nouvelle Découverte and Forêts de Grand Bassin, L. S. Bouton s.n. (holotype, K!).

Trees, 1.5–3 m tall; *branches* terete to quadrangular, when young glabrous or puberulent with indumentum drying yellow, becoming glabrescent, 8–9 mm diam.; internodes 0.7–2 cm, smooth. *Leaf* blades 12.5–42 × 3.5–11.5 cm, elliptic to elliptic-oblong or oblanceolate, apex shortly acuminate or acute, base cuneate, drying coriaceous, adaxially glabrous, abaxially glabrous or puberulent with indumentum drying brown or yellow; secondary veins prominulous abaxially, 8 to 16(to 20) pairs; domatia absent; petioles 20–40 mm. *Stipules* calyptrate, puberulent or glabrous, drying chartaceous, caducous, tube 20–25 mm, with ribs 4, broadly winged, arising below petiole and extending to lobes, apex with 2 incisions, marcescent, lobes 2, 2–3 mm, deltate to linear. *Inflorescences* cymose, many-flowered, terminal on principal and/or axillary branches, glabrous to densely puberulent; peduncle 1–4 cm; branched portion corymbiform, 8–10 × 12–13.5 cm, branched to 4 to 5 orders, lax; bracts deltate or trifid, 3–12 mm; bracteoles triangular to ovate, 1–2 mm; pedicels 1.5–3 mm. *Flowers* 5-merous, heterodistylous. *Long-styled flowers*: calyx cup-shaped, 3–4 mm wide, outside glabrous or puberulent, with hair-ring inside, truncate or lobes to 0.5 mm, rounded; corolla white, clavate in bud, when open salverform, glabrous throughout, tube 17–18 mm, 3–4 mm diam., lobes 8–9 mm, elliptic-oblong, obtuse; anthers included, filaments inserted in upper third of corolla tube, 0.5–1 mm; style 18–19 mm, glabrous or often pubescent in upper part, stigma ca. 1.5 mm. *Short-styled flowers*: mature corolla, stamens, and stigmas not seen. *Drupes* whitened to blue, obovoid to ellipsoid, 23–28 × 12–16 mm, ribbed; pyrenes plano-convex, rugose, finely fissured, endosperm entire.

Distribution and habitat. This species grows in Mauritius, where it can be found in wet forests and lower montane forests at elevations of 500–700 m.

Phenology. This species has been collected with flowers in June and December and with fruits in May.

Discussion. *Gaertnera longifolia* is a distinctive species with relatively large, elliptic-oblong or oblanceolate leaves that dry coriaceous and relatively large, obovoid to ellipsoid fruits. The label data of *Lorence 2224* note a “slight” fragrance. Verdcourt (1983) separated the pubescent-leaved plants as *G. longifolia* var. *pubescens* Verdc. This variety was only known from an early 19th-century Bojer collection and was considered extinct until Page and D’Argent rediscovered three individual trees growing in an area

in Black River Gorges National Park dominated by invasive species (Anonymous, 1997). These varieties are not separated here; the variation in pubescence is the only character that distinguished them, and this feature seems to show continuous variation rather than separating two distinct populations.

Representative specimens examined. MAURITIUS. Perrier Nature Reserve, *Lorence 2224* (MO), *Vaughan MAU 10387* (MAU), *Vaughan MAU 14123* (MAU); Black River Gorges National Park, *Malcomber 2935* (MO), *Page MAU 22729* (MAU).

40. *Gaertnera longivaginalis* (Schweinf. ex Hiern) E. M. A. Petit, Bull. Jard. Bot. État Bruxelles 29: 45. 1959, as “*longevaginalis*.” Basionym: *Psychotria longivaginalis* Schweinf. ex Hiern, Fl. Trop. Afr. 3: 201. 1877, as “*longevaginalis*.” TYPE: Belgian Congo [Democratic Republic of the Congo]. Forestier Central Distr. [Équateur?]; Kapili River, Apr. 1870, *G. A. Schweinfurth 3552* (holotype, K!; isotypes, BM!, P!).

Trees or shrubs, 1–6(–8) m tall; *branches* terete, glabrous to puberulent, 2–3(–6) mm diam.; internodes 1.5–6.5 cm, smooth. *Leaf* blades (3–)5.5–18.5 × (0.7–)2.3–8 cm, elliptic to oblanceolate, elliptic-oblong, or oblong, apex cuspidate or acuminate, base acute to obtuse, drying chartaceous, adaxially glabrous, abaxially glabrous or sparsely hirtellous on principal veins; secondary veins prominulous abaxially, 5 to 8 pairs; domatia absent or present; petioles 5–15 mm. *Stipules* tubular, glabrous to puberulent or pilosulose, drying membranous, caducous or with persistent base 1–2 mm, tube 8–28 mm, with ribs absent or 3 or 4, narrowly winged, arising above to below petiole and sometimes extending to lobes, apex entire or with 1 incision, marcescent, lobes 4, 1–8 mm, deltate to filiform. *Inflorescences* cymose, several- to many-flowered, terminal on principal and/or axillary branches, puberulent to pilosulose or hirtellous, sessile or peduncle to 6.5 cm; branched portion corymbiform, 1–10 × 1.2–15 cm, lax to congested, branched to 3 or 4 orders; bracts deltate or trifid, 3–18 mm, entire or ciliate; bracteoles 0.5–2 mm; pedicels absent or to 1 mm. *Flowers* 5-merous, heterodistylous. *Long-styled flowers*: calyx cup-shaped, 2–3.5 mm wide, glabrous outside, with hair-ring inside, lobes 0.2–4.5 mm, triangular to lanceolate; corolla white, clavate in bud, when open infundibuliform or salverform, outside glabrous, tube 4–6 mm, 1–3.5 mm diam., inside villous in upper third; lobes 2.5–5 mm, linear to ligulate; anthers shortly exerted, filaments inserted in upper third of corolla tube, ca. 0.5 mm; style 5–7 mm, glabrous or pubescent in upper portion, stigmas 0.8–2 mm. *Short-styled flowers*: similar to long styled except calyx 1–

3.5 mm wide, lobes 0.5–2.9 mm, triangular to lanceolate; corolla tube 1–4 mm diam., lobes 3–5 mm, triangular to ligulate or ovate-oblong; anthers fully exerted, filaments 3–6 mm; style 3.5–5 mm, stigmas 0.5–2 mm. *Drupes* violet-black, globose to subglobose or didymous, 5–10 × 5–12 mm; pyrenes spherical or hemispherical, rugose, finely fissured, endosperm entire.

Distribution and habitat. This species grows in West and Central Africa, where it is known from Angola, Cameroon, the Democratic Republic of the Congo, the Republic of the Congo, Gabon, Guinea, Côte d'Ivoire, Liberia, and Sierra Leone. Here, it is found in humid forests at elevations of 150–1600 m.

Phenology. This species has been collected with flowers and fruits throughout the year.

Discussion. This species belongs to the *Gaertnera vaginans* complex; see also the discussion of that group for related species and their distinctions. This name was originally published as “*longevaginalis*,” but the ICBN mandates a spelling correction for this variant (McNeil et al., 2006). Van Beusekom (1967) included *G. longivaginalis* in *G. vaginans* subsp. *vaginans*, but that is circumscribed more narrowly here; consequently, several taxa included by van Beusekom are separated here. *Gaertnera longivaginalis* differs from *G. vaginans* in its tubular stipules that dry membranous, closely envelop the stem, and have prominent filiform lobes at the apex.

Petit (1959a) recognized *Gaertnera longivaginalis* and *G. bracteata* as separate species, but with more specimens available now, these are not completely distinct morphologically and are treated here as varieties. These differ morphologically as outlined in the key below and also in elevational and geographic ranges, with variety *longivaginalis* documented widely from West through Central Africa at 150–1000 m versus variety *bracteata* documented from West Africa through the Republic of the Congo at 1100–1600 m.

- 1a. Calyx with tube 1–1.75 mm long, lobes 1.2–4.5 mm long; inflorescence bracts deltate to usually linear-lanceolate 40a. variety *bracteata*
1b. Calyx with tube 1.5–2.5 mm long, truncate or with lobes to 1 mm long; inflorescence bracts deltate to usually elliptic 40b. variety *longivaginalis*

40a. *Gaertnera longivaginalis* var. *bracteata* (E. M. A. Petit) Malcomber, comb. et stat. nov.
Basionym: *Gaertnera bracteata* E. M. A. Petit, Bull. Jard. Bot. État Bruxelles 29: 49. 1959.
TYPE: Congo [Republic of the Congo]. Kasai Distr.: Butala, Nov. 1903, *E. Laurent & M. Laurent s.n.* (holotype, P!).

Gaertnera bracteata var. *glabrifolia* E. M. A. Petit, Bull. Jard. Bot. État Bruxelles 29: 50. 1959, syn. nov. TYPE: Belgian Congo [Democratic Republic of the Congo]: Distr. Forestier Central [Equateur], Ilenge, Nov. 1921, *V. G. Goossens 2688* (holotype, BR!; isotypes, G!, P!).

Trees, 1–4 m tall; *branches* 2–3 mm diam. *Leaf* blades 3–15 × 0.7–6 cm, elliptic to elliptic-oblong; petioles 5–10 mm. *Stipules* with tube 8–24 mm, with ribs none or 4, lobes 3–8 mm, filiform to narrowly triangular. *Inflorescences* densely pilosulose to hirtellous; peduncle 1–6 cm; branched portion 1.2–15 cm wide; bracts deltate to linear-lanceolate, 3–18 mm, ciliolate; pedicels absent or to 0.3 mm. *Long-styled flowers*: calyx 2–3 mm wide, with tubular part 1–1.75 mm, lobes 1.2–4.5 mm, triangular to lanceolate; corolla tube 4–5 mm, 1–2.5 mm diam; lobes 3–5 mm, linear to ligular or elliptic-oblong. *Short-styled flowers*: similar to long styled except calyx 1–2.5 mm wide, lobes 1.2–2.9 mm; corolla tube 4–6 mm; filaments 4–6 mm; style 4–5 mm, stigmas 0.5–1 mm. *Drupes* 5–10 × 5–12 mm.

Distribution and habitat. This variety grows in Central and West Africa, where it has been found in the Democratic Republic of the Congo, the Republic of the Congo, Guinea, Côte d'Ivoire, Liberia, and Sierra Leone. Here, it can be found in humid forests at elevations of 1100–1600 m.

Phenology. This variety has been collected with flowers and fruits throughout the year.

Discussion. *Gaertnera longivaginalis* var. *bracteata* has been confused with *G. cooperi*, and some specimens cited in the original description of that species are not conspecific with its type and are included here (Petit, 1959a). This variety is similar to *G. bieleri* and *G. leucothyrsa*; those can be distinguished by the well-developed stipular ridges or wings that surround the base of the petiole, and *G. bieleri* additionally by its pilosulose to hirtellous stems and stipules.

Petit (1959a) separated *Gaertnera bracteata* var. *glabrifolia* E. M. A. Petit based on its abaxial leaf surfaces completely glabrous rather than sparsely hirtellous along the principal veins. However, the criteria applied in this current revision for distinguishing taxa are different, and here this variation in pubescence is considered to be a character that varies among local populations or among individual plants, and thus is not indicative of distinct, separately evolving evolutionary lineages. Accordingly, this variety is not considered to describe a distinct taxonomic lineage and is synonymized here.

Representative specimens examined. DEMOCRATIC REPUBLIC OF THE CONGO. Ligasa, Lokombe River (T. Isangi), *Germain 8501* (BR). GUINEA [GUINEA-CONAKRY]. Crête, *Adam 28771* (MO, WAG); Mt. Nimba, *Adam*

4697 (P). IVORY COAST [CÔTE D'IVOIRE]. Mt. Nimba, *Gautier-Beguín & Gautier-Beguín 1263* (G, MO); Tonkoui Massif, *Hallé 380* (P). LIBERIA. Bomi Hills, *Jansen 1515* (K, MO, WAG); Nimba, *Breteler 5458* (MO, P, WAG). REPUBLIC OF THE CONGO. Alima-Likouala Basin, Fort Rousset, *Descoings 8539* (P, WAG). SIERRA LEONE. Mt. Loma, *Jaeger 7158* (K, MO, P, WAG); Nongowa, Kambui Hills, *Bakshi 184* (K, P).

40b. *Gaertnera longivaginalis* (Schweinf. ex Hiern) E. M. A. Petit var. ***longivaginalis***.

Gaertnera plagiocalyx K. Schum. ex Thonn. & H. Durand, Syll. Fl. Congol. 373. 1909. [West Afr. Kautschuk-Exped. 322. 1900, nom. nud.]. TYPE: Belgian Congo [Democratic Republic of the Congo]. Kinshasa: Leopoldville [Kinshasa], Stanley Pool, June 1899, *R. Schlechter 12586* ([holotype, B†]; lectotype, designated here, BM!; isotypes, BR!, G!, K!, L!, P!).

Gaertnera longivaginalis var. *louisii* E. M. A. Petit, Bull. Jard. Bot. État Bruxelles 29: 48. 1959, syn. nov. TYPE: Belgian Congo [Democratic Republic of the Congo]. Distr. Forestier Central, Orientale, Yangambi et environs, ca. 460 m, *J. Louis 12577* (holotype, BR!).

Trees or shrubs, 1–6(–8) m tall; *branches* 2–3(–6) mm diam. *Leaf* blades (3–)5.5–18.5 × (0.8–)2.3–8 cm, elliptic to elliptic-oblong or oblanceolate; petioles 10–15 mm. *Stipules* with tube 10–28 mm, with ribs 3 or 4, lobes 1–5.5 mm, deltate to filiform. *Inflorescences* densely puberulent to pilosulose, sessile or peduncle to 6.5 cm; branched portion 1.5–15 cm wide; bracts elliptic to deltate, 3–10 mm, entire; pedicels absent or to 1 mm. *Long-styled flowers*: calyx 2–3.5 mm wide, lobes 0.1–1 mm, triangular to broadly triangular; corolla tube 4–6 mm, 1.5–3.5 mm diam.; lobes 2.5–3.5 mm, ligulate. *Short-styled flowers*: similar to long styled except calyx lobes 0.5–1 mm; corolla tube 4–5.5 mm, 1.4–4 mm diam.; filaments 3–3.5 mm; style 3.5–4.5 mm, stigmas 1.5–2 mm. *Drupes* 5–8 × 5–8 mm.

Distribution and habitat. This variety grows in West and Central Africa, Angola, Cameroon, the Democratic Republic of the Congo, the Republic of the Congo, Gabon, Guinea, Côte d'Ivoire, Liberia, and Sierra Leone. Here, it can be found in humid forests at elevations of 150–1000 m.

Phenology. This species has been collected with flowers and fruits throughout the year.

Discussion. Petit (1959a) separated *Gaertnera longivaginalis* var. *louisii* based on its inflorescence with the branched portion 1–6 cm long with two or three pairs of secondary axes and its abaxial leaf surfaces sparsely pubescent along the principal veins or less often glabrous, versus inflorescences with the branched portion 1.5–9 cm long with two to five pairs of secondary axes and the abaxial leaf surfaces glabrous or less often pubescent along the costa.

The conditions that characterized each of Petit's variety are thus similar and do not separate two clearly distinguishable groups of plants. Thus, the criteria applied in this current revision to distinguish taxa, the clear separation of distinct groups, are not met and so this variety is not recognized here and is synonymized accordingly.

The holotype of *Gaertnera plagiocalyx* was destroyed with the general Rubiaceae collection in the Berlin herbarium; the isotype at BM is selected as the lectotype here because it has a digital image available on the Aluka web site and is the best representative of this species among the digitally imaged isotypes there.

Representative specimens examined. ANGOLA. Rio Luachimo, near Vila Henrique de Carvalho, *Exell 708* (BM). CAMEROON. Awout River, 42 km SE of Mbalmayo, *Asonganyi 34* (BR, P); Dja, betw. Meu & Edjune rivers, *Letouzey 3780* (MO, P, WAG); M'Balmayo, ca. 50 km S of Yaoundé, *Mpom 334* (BR, P); Membe & Guervoum, *Letouzey 2116* (BR, MO, P). DEMOCRATIC REPUBLIC OF THE CONGO. Api, *Robyns 1237* (BR, FHO, G); Eala, *Corbisier 1120* (BM, BR, FHO); Imbonga (Territory Ingende), *Evrard 6083* (BR, FHO); Léopoldville, *Goossens 6197* (BR, FHO); Liaka (Basankusu Territory), Yangambi, Tutuku Island, Isalowe Plateau, *Louis 9169* (BR, K, MO). GABON. **Ogooué-Ivindo:** Ivindo River, L bank, 11 km SSW of Makokou, *Leeuwenberg 11508* (BR, K, MO, P); Lope Reserve, bank of Ogooué River, *J. de Wilde 11449* (WAG). **Ogooué-Lolo:** Lastoursville, *Le Testu 7622* (BM, BR, MO, P). GUINEA [GUINEA-CONAKRY]. Nzo-Nimba, *Adam 27518* (BR, MO, WAG). IVORY COAST [CÔTE D'IVOIRE]. Mont Tonkoui, *Bamps 2263* (BR, P). LIBERIA. Mt. Wolagisi, near Pandamai, *Bequaert 106* (K). REPUBLIC OF THE CONGO. Alima-Likouala Basin, Fort Rousset, *Descoings 8282* (P, WAG), *8664* (WAG); Brazzaville, *Chevalier 27743* (P), *Harder 3751* (MO). SIERRA LEONE. Mt. Loma, *Jaeger 1166* (MO, P, WAG).

41. *Gaertnera lowryi* Malcomber, sp. nov. TYPE: Madagascar. Toamasina: Masoala National Park, West Coast, near Antalavia, 0.8 km NE of village, lowland forest beside Antalavia River, 15°47'S, 50°02'E, 50–150 m, 12 Oct. 1997, *S. T. Malcomber 2827* (holotype, MO!; isotypes, BR!, G!, K!, P!, PRE!, TEF!, WAG!). Figure 7C–H.

Haec species *Gaertnerae vaginanti* (DC.) Merr. similis, sed ab ea foliorum anguste ellipticorum vel oblanceolatorum venis secundariis 13- ad 18-jugatis atque stipulis manifeste quadrangularibus apice semel fassis in quoque latere tubi ac sub petiolo alis duabus prominentibus munitis distinguitur.

Trees, 2–8 m tall; *branches* ± tetragonal, glabrous, 4–8 mm diam.; internodes 5.8–12.5 cm, smooth. *Leaf* blades 29–40 × 5.3–8.4 cm, elliptic or oblanceolate, apex acuminate or acute, base cuneate to rounded, drying coriaceous, glabrous; secondary veins prominent abaxially, 13 to 18 pairs; domatia absent; petioles 5–30 mm. *Stipules* tubular, glabrous, drying chartaceous, deciduous after distalmost 1 to 3 nodes,

often by fragmentation, tube 29–80 mm, with ribs 4, broadly winged, arising below petiole and extending to lobes, apex with 1 deep incision, marcescent, lobes 4, 4–10 mm, deltate. *Inflorescence* cymose, many-flowered, terminal on axillary branches, pendulous, densely puberulent; peduncle 5–16 cm; branched portion corymbiform or broadly pyramidal, 9–21 × 6–17 cm, branched to 3 to 4 orders, lax to congested; bracts deltate or linear to ligulate, 2.3–18 mm; bracteoles triangular to ligulate or lanceolate, 0.5–2 mm; pedicels absent or to 2.5 mm. *Flowers* 5-merous, heterodistylous. *Long-styled flowers*: calyx cup-shaped, 2–3 mm wide, outside glabrous or puberulent, glabrous inside, lobes 0.1–0.3 mm, triangular; corolla white, clavate in bud, when open salverform or infundibuliform, outside glabrous, tube 18–21 mm, 1.5–4 mm diam., inside villous at ca. middle, lobes 4–5 mm, triangular to ligulate, acute; anthers included, filaments inserted at ca. middle of corolla tube, 0.3–1 mm; style 18–21 mm, glabrous, stigmas 2.5–3 mm. *Short-styled flowers*: similar to long styled except calyx urceolate or cup-shaped, truncate or lobes to 0.3 mm; corolla outside glabrous or puberulent; tube 17.5–20 mm, 1.5–5.5 mm diam., lobes 4.5–5 mm; anthers shortly exerted, filaments inserted in upper third of corolla tube, 2.4–3 mm; style 8.5–10 mm, stigmas 3–3.5 mm. *Drapes* unknown.

Distribution and habitat. This species grows in Madagascar, where it is known from the province of Toamasina in the Mananara area and on the Masoala Peninsula. Here, it can be found in humid forests at elevations of 0–600 m.

Phenology. This species has been collected with flowers January through August and October through December, and with fruits in October.

Discussion. *Gaertnera lowryi* is similar to *G. letouzeyi* of Central Africa, but can be distinguished by its elliptic or oblanceolate leaves, 13 to 18 pairs of secondary veins, and pale greenish white calyx tube. In the field, *G. lowryi* is an impressive species with a pendulous inflorescence and reflexed uppermost leaves. *Gaertnera lowryi* is named for Porter Prescott “Pete” Lowry II (1956–), who made some of the first collections of the species and has made a number of important botanical collections from the Masoala Peninsula of Madagascar.

Paratypes. MADAGASCAR. **Toamasina:** Mananara-Nord National Park, *Malcomber et al.* 2888 (MO, TEF); Maroantsetra, Andranofotsy, Sahavary, *Schatz et al.* 1866 (MO), Hiaraka toward the rock, *Lowry et al.* 4036 (MO, TAN); Masoala Peninsula, Ambanizana, *Lowry et al.* 4155 (MO, P, TAN), *Malcomber et al.* 2742 (MO, TAN); Andranobe, *Malcomber* 2800 (MO, TEF), *Zjhra & Hutcheon* 392 (MO).

42. *Gaertnera macrobotrys* Baker, J. Linn. Soc., Bot. 20: 208. 1883. *Sykesia macrobotrys* (Baker) Kuntze, Revis. Gen. Pl. 2: 425. 1891. TYPE: Madagascar. Central Madagascar, *R. Baron* 1945 (holotype, K!; isotype, P!).

Trees or shrubs, 3–10 m tall; *branches* quadrangular, glabrous, 5–7 mm diam.; internodes 1.4–9.5 cm, smooth. *Leaf* blades 7.5–26 × 3.8–13 cm, elliptic-oblong to ovate or occasionally oblanceolate, apex rounded then sometimes abruptly cuspidate, base rounded to truncate, drying coriaceous or chartaceous, glabrous; secondary veins prominulous abaxially, 8 to 10 pairs; domatia absent; petioles 10–25 mm. *Stipules* tubular, inflated to funnel-shaped, glabrous, drying chartaceous, persistent on distalmost 1 to 2 nodes to deciduous often through fragmentation, often leaving a well-developed annular scar, tube 7–20 mm, with ribs none or 4, rounded to narrowly winged, arising beneath petiole and extending to base of tube, apex with 2 incisions, marcescent, lobes 4, 0.5–1 mm, deltate. *Inflorescences* cymose, many-flowered, terminal on principal and/or axillary branches or axillary, glabrous or puberulent; peduncle 1.5–10 cm; branched portion corymbiform, 5–15 × 4–22 cm, branched to 4 to 6 orders, lax to congested; bracts deltate or trifid, 1–10 mm; bracteoles triangular to lanceolate, 0.5–1.5 mm; pedicels absent or to 1.8 mm. *Flowers* 5-merous, heterodistylous. *Long-styled flowers*: calyx cup-shaped, 2–3 mm wide, outside glabrous, inside glabrous or usually with hair-ring, truncate or rarely with lobes to 0.3 mm, triangular; corolla white or pink, clavate in bud, when open salverform, outside glabrous, tube 7–10 mm, 2–3.5 mm diam., inside villous in upper third, lobes 2–2.5 mm, triangular to ligulate, acute; anthers included, filaments inserted at ca. middle of corolla tube, 0.8–1 mm; style 7–9 mm, glabrous or often pubescent near apex, stigmas 0.5–1.1 mm. *Short-styled flowers*: similar to long styled except calyx 1.5–3 mm wide, glabrous inside; corolla tube 6.5–10 mm, 1.5–3.5 mm diam., lobes ca. 3 mm; anthers shortly exerted, filaments inserted in upper third of corolla tube, 2–3 mm; style 4.5–5 mm long, stigmas 1.5–2 mm. *Drapes* violet-black, globose or subglobose, 8–9 × 8–10 mm; pyrenes spherical or hemispherical, rugose, finely fissured, endosperm entire.

Distribution and habitat. This species grows in Madagascar, where it is known from the provinces of Fianarantsoa and Toamasina. Here, it can be found in humid forests at elevations of 660–1100 m.

Phenology. This species has been collected with flowers January through March and October through

December, and with fruits January through August and October through December.

Discussion. *Gaertnera macrobotrys* is similar to *G. arenaria*, *G. monstrosa*, and some plants of *G. obovata* var. *sphaerocarpa* with relatively large leaves (*G. macrobotrys* is easily separated from the remaining plants of *G. obovata* var. *sphaerocarpa* by its much larger leaves). However, *G. macrobotrys* can be distinguished from these by its elliptic-oblong to ovate or oblanceolate leaves, its inflated to funnel-shaped, shortly persistent to deciduous stipules that are partially split into two large, ovate lobes, and its usually terminal inflorescences. *Gaertnera macrobotrys* is also similar to *G. macrostipula*, but differs from it in its stipules usually deciduous after the top one or two nodes and usually elliptic-oblong or ovate leaves.

Representative specimens examined. MADAGASCAR. **Fianarantsoa:** Ranomafana National Park, *Malcomber* 2585 (K, MO, P, TAN), *Kotozafy* 267 (MO, P); Vohipeno, *Beaujard* 183 (K), 387 (K). **Toamasina:** Andasibe, Perinet, *Benoist* 1520 (P, TAN), *Dorr* 3222 (TAN), *Lowry* 4272 (P, TAN), *Miller* 3818 (MO, P, TAN), *Unknown Collector SF* 4250 (P, TEF); Mananara National Park, near Antanambe, *Morat* 8576 (P).

43. *Gaertnera macrostipula* Baker, J. Linn. Soc., Bot. 20: 207. 1883. *Sykesia macrostipula* (Baker) Kuntze, Revis. Gen. Pl. 2: 425. 1891. TYPE: Madagascar. Central Madagascar, *R. Baron* 1922 (lectotype, designated here, K!; isotypes, K!, P!).

Trees or shrubs, 2–7 m tall; branches flattened or terete or quadrangular, glabrous or puberulent with indumentum drying brown, 4–7 mm diam.; internodes 1.8–7 cm, smooth. Leaf blades 3.5–24 × 1.8–14.5 cm, oblanceolate to obovate, elliptic, or ovate, apex rounded then shortly cuspidate or acute, base acute and often decurrent, drying chartaceous, adaxially glabrous, abaxially glabrous or hirtellous along principal veins; secondary veins prominulous abaxially, 7 to 11(to 13) pairs; domatia absent or rarely present; petioles 18–20 mm. Stipules tubular, cylindrical or often inflated to funnel-shaped, glabrous or rarely puberulent, drying chartaceous, persistent, tube 10–33 mm, with ribs 4, rounded to narrowly winged, arising below petiole and sometimes extending along tube to lobes, apex entire or with 2 incisions, marcescent, lobes absent or 4, 1–2 mm, deltate. Inflorescences cymose, many-flowered, terminal on principal and/or axillary branches, sparsely to densely puberulent, pilosulose, or rarely glabrous; peduncle 2.5–11 cm; branched portion corymbiform, (1–)3–19 × (1–)4–16(–20) cm, branched to 3 to 5 orders, lax to congested; bracts deltate or trifid, 3–15 mm; bracteoles triangular, 1–3.5 mm; pedicels absent or to 2 mm. Flowers 5-merous, heterodistylous.

Long-styled flowers: calyx campanulate, 2–3.5 mm wide, outside sparsely to densely puberulent or glabrous, glabrous inside, truncate or lobes 1–3.5 mm, equal to markedly unequal, linear to spatulate; corolla white to dark pink, clavate in bud, when open infundibuliform or salverform, outside puberulent (glabrous), tube 7.5–8.5 mm, 2–3.5 mm diam., inside villous in upper third; lobes 2.5–3 mm, ligulate, acute; anthers included, filaments inserted in upper third of corolla tube, 0.5–1 mm; style 9–10 mm, glabrous, stigmas 0.5–1 mm. *Short-styled flowers:* similar to long styled except calyx lobes absent or 1.5–3.5 mm; corolla tube 6.5–9 mm, 1.3–3.5 mm diam., inside glabrous, lobes 2–3 mm, ligulate or linear; anthers shortly exerted, filaments 1–4 mm; style 2.5–3 mm, glabrous or pubescent, stigmas (0.2–)0.8–2 mm. Drupes violet-black, globose to subglobose or didymous, 7–9 × 7–9.5 mm; pyrenes spherical or hemispherical, rugose, finely fissured, endosperm entire.

Distribution and habitat. This species grows in Madagascar, where it is widespread. It lives in humid forests at elevations of 0–1800 m.

Phenology. This species has been collected with flowers January through March and August through December, and with fruits January through May and in November and December.

Discussion. This common species can be recognized by its well-developed, often funnel-shaped stipules that loosely surround the stem; additionally, on many stems the stipules are almost as long as the internodes and thus mostly cover the entire stem. The calyx lobes are usually linear to spatulate and well developed but rarely are absent. The flowers are usually dark pink but often bleach white in the sun. *Gaertnera macrostipula* is one of the most commonly collected *Gaertnera* species in Madagascar, growing in a variety of forest types from littoral forest near sea level to moss forest at 1800 m. It is similar to *G. macrobotrys*; see also comments under that species.

Two syntypes were cited in the protologue, *R. Baron* 1922 (K!, P!) and *W. T. Gerrard* 54 (K!). The former is selected here as lectotype because it is a more complete and exemplary specimen and has duplicates; the lectotype specimen is selected because it is the most complete specimen of the set.

Representative specimens examined. MADAGASCAR. **Antsiranana:** Anjanaharimbe Massif, *Humbert* 24621 (P); Anjanaharimbe-sud Nature Reserve, *Malcomber* 2676 (MO); Besinkara, *Gautier* 2514 (G, MO, P); Marojejy Nature Reserve, *Morat* 4150 (TAN), *S. Malcomber* 2705 (MO), 2709 (MO), 2774 (MO), 2777 (MO), 2778 (MO), 2782 (MO). **Fianarantsoa:** Ambodiamontana, Ranomafana, *Seigler* 12802 (MO); Matitanana Basin, Rienana Valley, *Humbert*

3450 (MO, P). **Toamasina:** Mantadia National Park, *Malcomber 2920* (MO), *McPherson 16553* (MO); Ambodiriana, *Perrier de la Bâthie 17449* (MO, P); Andavikimenarana, *Dorr 4484* (MO); Didy, Brickaville, *Cours 4879* (P); Masoala National Park, *Malcomber 2807* (MO), *2834* (MO); Masoala Peninsula, *Perrier de la Bâthie 3649* (P).

44. *Gaertnera madagascariensis* (Hook. f.) Malcomber & A. P. Davis, *Monogr. Syst. Bot. Missouri Bot. Gard.* 104: 388, figs. 4, 5. 2005. Basionym: *Hymenocnemis madagascariensis* Hook. f., *Gen. Pl.* 2: 132. 1873. TYPE: Madagascar. s. loc., *W. Bojer s.n.* (holotype, K!).

Trees, 2–5 m tall; *branches* terete, when young densely pilosulose to villosulous, strigose, or sericeous with indumentum drying gray-white or brown to orange, sometimes becoming glabrescent, 0.4–3 mm diam.; internodes 0.4–2.5 cm, smooth. *Leaf* blades 0.5–4 × 0.3–2.5 cm, ovate to elliptic or obovate, apex acute to shortly acuminate (obtuse), base cuneate to rounded, drying chartaceous, glabrous; secondary veins visible and flat to prominulous abaxially, 3 to 5(6) pairs; domatia present; petioles 0.5–2.5 mm. *Stipules* calyptrate, densely villosulous to pilosulose or strigillose, drying membranous, caducous, persistent on distalmost 3 to 4 nodes, or deciduous through fragmentation, tube 3.5–23 mm, with ribs 4, narrowly winged, arising beneath petiole and sometimes extending along tube, apex with 1 incision, lobes 2, 0.3–0.6 mm, deltate. *Inflorescences* 1- to 3-flowered, fasciculate, terminal on principal and/or axillary branches; peduncles 2.5–12 mm, strigose to sericeous; bracts deltate, to 5 mm, glabrous or puberulent; bracteoles absent. *Flowers* 5-merous, heterodistylous. *Long-styled flowers:* calyx campanulate, 1.2–2.5 mm wide, glabrous, lobes 0.5–4 mm, triangular to linear; corolla white, clavate in bud, when open salverform, throughout glabrous, tube 5–10 mm, 2–4 mm diam.; lobes 3–5 mm, ligulate to elliptic-oblong, acute; anthers included, filaments inserted in upper third of corolla tube, 0.1–0.4 mm; style 7–10 mm, glabrous, stigmas 0.3–0.7 mm. *Short-styled flowers:* unknown. *Drupes* violet-black, globose or subglobose, 5–6 × 5–6 mm; pyrenes spherical to hemispherical, rugose, finely fissured, endosperm entire.

Distribution and habitat. This species grows in Madagascar, where it is widespread in the eastern escarpment. Here, it is found in humid evergreen forests on metamorphic and igneous rocks and rarely on alluvial deposits, at elevations of 800–1400 m.

Phenology. This species has been collected January through March and in November and December, and with fruits March through May.

Discussion. This species was originally separated in a monotypic genus, but molecular analyses indicate that *Hymenocnemis madagascariensis* is nested within the *Gaertnera* clade (Malcomber, 2002; Malcomber & Davis, 2005) and support its inclusion within *Gaertnera*. *Hymenocnemis* was originally circumscribed based on its superior ovary in the fruit, “sheathing” stipules, and inflorescence reduced to a single flower. All of these characters are found within *Gaertnera*, and this species also has *Gaertnera*’s characteristic stipular wings encircling the petiole. *Gaertnera madagascariensis* can be recognized by its densely appressed-pubescent young branches and stipules, its membranous calyptrate stipules, and its inflorescence reduced to one or a few flowers. This is the most commonly collected species in Madagascar of the group of *Gaertnera* species with solitary or few flowers discussed by Malcomber and Davis (2005). *Gaertnera madagascariensis* is similar to *G. brevipedicellata*; see additional comments under that species. Malcomber and Davis (2005) considered the conservation status of this species to be Least Concern (IUCN).

Representative specimens examined. MADAGASCAR. **Antananarivo:** Anjozorabe, *Bosser 12839* (K, P, TAN), 8200 (TAN); Ankeramadranka, Ambatolaona, 65 km E of Antananarivo, *Leandri 3204* (P). **Fianarantsoa:** Andringitra Massif, Ambodipaiso Forest, *Cours 2286* (P), *Homolle 2286* (P, TAN); Ranomafana National Park, Vatoharanana, *Malcomber 2865* (MO), *2870* (MO). **Toamasina:** Analamazoatra, *Perrier de la Bâthie 6892* (K, P); Bemainty Massif, Rahobeava, *Cours 4177* (P, TAN).

45. *Gaertnera microphylla* Capuron ex Malcomber & A. P. Davis, *Monogr. Syst. Bot. Missouri Bot. Gard.* 104: 390, figs. 2, 6. 2005. TYPE: Madagascar. Toamasina: 6.6 km SE of Andasibe, small ridge beside RN2 at base of Andriandavibe, 18°56’S, 48°29’E, 23 Nov. 1997, *S. T. Malcomber, A. P. Davis, D. Gower & J. Andriantiana 2925* (holotype, MO!; isotypes, A!, BR!, G!, K!, LE!, MAL!, MAU!, P!, PRE!, TEF!, UPS!, WAG!).

Trees or shrubs, 2–4 m tall; *branches* flattened to terete, glabrous, 0.4–3.4 mm diam.; internodes 0.1–0.6 cm, with 2 longitudinal ribs. *Leaf* blades 0.3–1.5 × 0.3–0.8 cm, cuneiform to spatulate or obovate, apex obtuse to acute or shortly acuminate or mucronulate, base acute to attenuate, drying membranous, glabrous; secondary veins hardly visible to prominulous abaxially, 3 to 4 pairs; domatia absent or present and foveolate; petioles 0.5–1.2 mm. *Stipules* calyptrate, glabrous, drying membranous, persistent, quickly splitting into 4 narrowly spatulate to linear segments, tube 4–5 mm, with ribs 4, narrowly to broadly winged, arising beneath petiole and extending

along each persistent segment; apex with 2 or 4 incisions, lobes 4, 1–1.5 mm, linear. *Inflorescences* reduced to 1 flower, terminal on axillary branches; bracts stipuliform, involucrel; bracteoles absent. *Flowers* 4-merous, heterodistylous, subsessile. *Long-styled flowers*: calyx cup-shaped, 1.5–2 mm wide, glabrous, lobes 2.4–3 mm, linear to oblanceolate or ligulate; corolla white, clavate in bud, when open salverform, outside glabrous, tube 4–4.5 mm, 1.5–3 mm diam., inside villous at ca. middle, lobes 2–2.5 mm, triangular to ligulate, obtuse; anthers included, filaments inserted in upper third of corolla tube, 0.2–0.4 mm; style 4.5–5 mm, glabrous, stigmas 0.9–1.3 mm. *Short-styled flowers*: unknown. *Drupes* blue, didymous, 5–6.2 × 6.5–7 mm; pyrenes hemispherical, rugose, finely fissured, endosperm entire.

Distribution and habitat. This species grows in Madagascar, where it is known from the province of Toamasina. Here, it can be found in wet evergreen forests on metamorphic and igneous rocks at elevations of 790–1050 m.

Phenology. This species has been collected with flowers in November and December and with fruits in March through May.

Discussion. This species is distinctive in its relatively small leaves that are broadest near the apex and its stipules that quickly split into four narrow, persistent segments. The stipules or stipule segments cover the stem and overlap due to the reduced internodes. The calyx with its well-developed narrow lobes resembles the stipules. This species is only known from around Andasibe and Analamazotra; it was given a conservation status of Critically Endangered (IUCN, 2001) by Malcomber and Davis (2005). *Gaertnera microphylla* and *G. furcellata* are similar and in particular share the unusual stipules and inflorescences reduced to a single flower; they differ primarily in their respective distinctive leaf shapes.

Additional specimens examined. MADAGASCAR. **Toamasina:** Betw. Perinet & Anevoka, base de rocher de l'Andriandavibe, *Capuron SF 24355* (MO, P, TEF), *SF 24770* (MO, P, TEF); region of Saharanga mountain pass, NE of Perinet, *Capuron SF 24022* (MO, P, TEF); Andasibe (Perinet), N of rd. from Antananarivo to Tametave, *Lowry & Schatz 4283* (MO).

46. *Gaertnera monstrosa* Malcomber, sp. nov.

TYPE: Madagascar. Toamasina: 6.4 km W of Antanambe, Mananara National Park, lowland rainforest, 16°27'S, 49°48'E (WGS 84 map datum), 180 m, 16 Nov. 1997, *S. T. Malcomber 2887* (holotype, MO!; isotypes, BR!, K!, P!, TEF!, WAG!). Figure 12A–D.

Haec species *Gaertnerae obesae* Hook. f. ex C. B. Clarke similis, sed ab ea caule in sectione transversali subquadrangulari, floribus hermaphroditis distylis atque tubo corollino 15–20 mm longo distinguitur.

Trees or shrubs, 1–5 m tall; *branches* quadrangular, glabrous, 2–15 mm diam.; internodes 3.5–26 cm, smooth. *Leaf* blades 35–51 × 10.5–14.6 cm, elliptic to oblanceolate or obovate, apex acuminate, base acute to cuneate, drying chartaceous to coriaceous, glabrous; secondary veins prominulous abaxially, 12 to 16 pairs; domatia absent; petioles 15–25 mm. *Stipules* tubular, funnel-shaped, glabrous, drying coriaceous, persistent at least on distalmost 3 or 4 nodes, tube 18–51 mm, with ribs 4, broadly winged, arising below petiole and extending to lobes, apex with 2 deep incisions producing 2 broadly oblong to elliptic segments, apices acute or sometimes tardily splitting, without lobes. *Inflorescences* cymose, many-flowered, terminal on principal and/or axillary branches or sometimes on reduced axillary branches and appearing axillary, puberulent, sessile or peduncle to 11 cm; branched portion corymbiform, 3.8–18.5 × 6–26 cm, branched to 3 to 4 orders, lax to congested; bracts deltate or trifid, 0.5–2.2 mm, sometimes glabrous; bracteoles triangular to rounded, 0.1–0.5 mm; pedicels absent or to 0.5 mm. *Flowers* 5-merous, heterodistylous. *Long-styled flowers*: calyx cup-shaped, 1.8–3 mm wide, outside puberulent, with hair-ring inside, truncate; corolla white, clavate in bud, when open salverform, glabrous throughout, tube 15–20 mm, 1.5–2.5 mm diam., lobes 3–4.5 mm, ligulate or elliptic-oblong, acute; anthers included, filaments inserted at middle to upper third of corolla tube, 1–2 mm; style 16–20 mm, glabrous, stigmas 2–3 mm. *Short-styled flowers*: similar to long styled except calyx 1.5–2.5 mm wide; corolla tube 12–13.5 mm, 1.8–2.5 mm diam., lobes 4–5 mm, ligulate; anthers included, filaments 1.2–1.4 mm; style 3.5–4 mm, stigmas 1.5–2 mm. *Drupes* unknown.

Distribution and habitat. This species grows in Madagascar, where it is known from the province of Toamasina, in the Soanierana-Ivongo and Mananara Nord National Parks. Here, it can be found in humid forests at elevations of 180–400 m.

Phenology. This species has been collected with flowers August through November but has not been collected with fruits.

Discussion. *Gaertnera monstrosa* is similar to *G. obesa* of Southeast Asia, but differs from that species in its more squared stems, larger flowers, and stamens inserted in the middle or upper third of the corolla tube. Additionally, *G. monstrosa* has bisexual distylous flowers, whereas *G. obesa* is dioecious. Within Madagascar, *G. monstrosa* is similar to *G. macrobotrys*, but can be separated from it by its

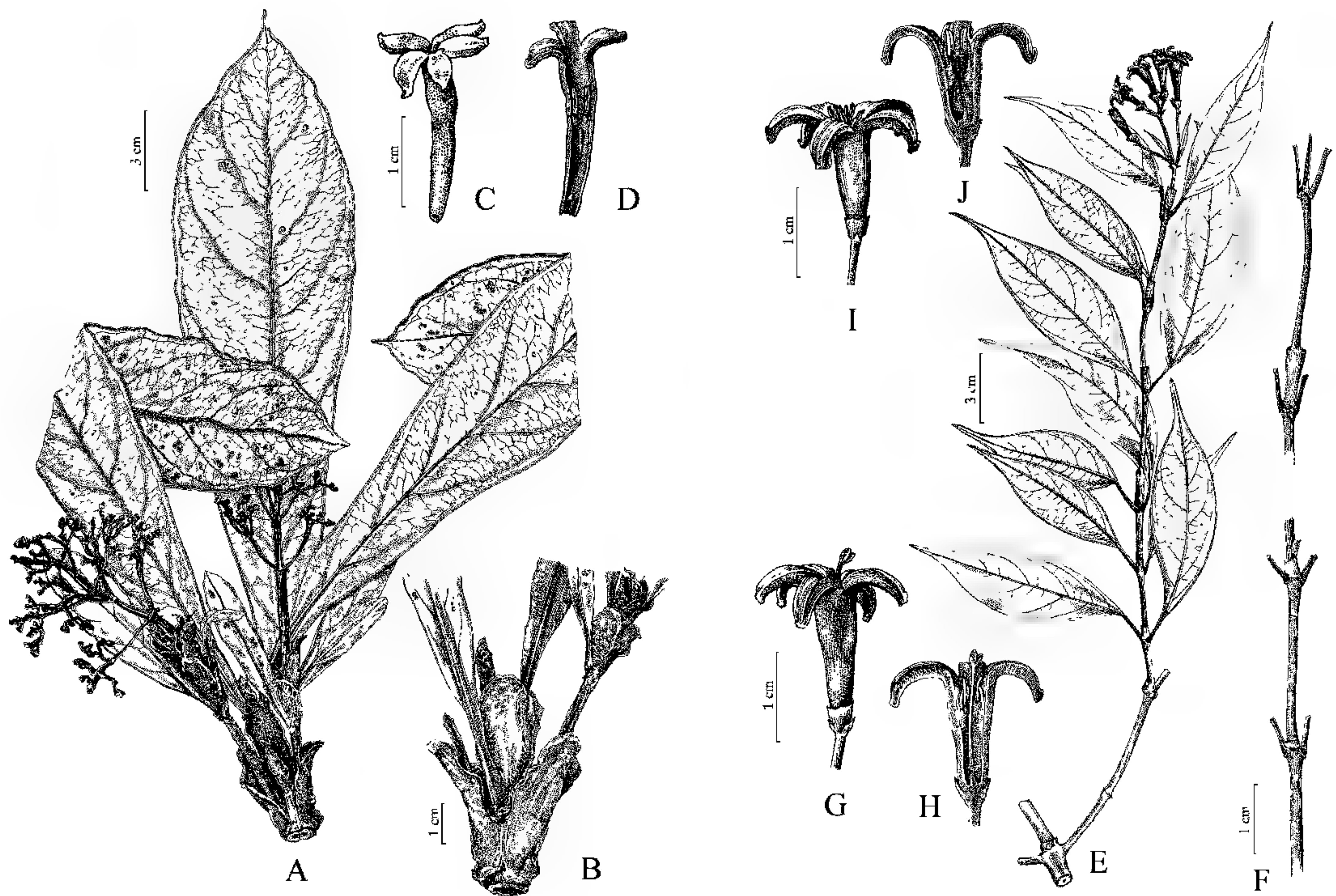

Figure 12. A–D. *Gaertnera monstrosa* Malcomber. —A. Fruiting branch. —B. Portion of stem with leaf bases and stipules. —C. Short-styled flower. —D. Short-styled flower in cross section. E–J. *Gaertnera walkeri* (Arn.) Blume. —E. Flowering branch. —F. Portion of stem with petiole bases, stipules, and stem apex. —G. Long-styled flower. —H. Long-styled flower in cross section. —I. Short-styled flower. —J. Short-styled flower in cross section. C, D to same 1-cm scale; G, H to same 1-cm scale; I, J to same 1-cm scale. A–D based on *Malcomber 2887*; E–J based on *Malcomber 2771*.

relatively large, elliptic to obovate or oblanceolate leaves, often apparently axillary inflorescences, and larger flowers. The specific epithet refers to the proportionally large size of the leaf blades, stipules, and stem.

Paratypes. MADAGASCAR. **Toamasina:** Mananara-Nord National Park, Ibanda, *Malcomber et al. 2909* (MO); S of Soanierana-Ivongo, Sahavolamena, *Capuron SF 23800* (TEF); Sahafotra, N of Navana (Bay of Antongil), *Capuron SF 28396* (TEF).

47. *Gaertnera obesa* Hook. f. ex C. B. Clarke, in Hook. f., *Fl. Brit. India* 4: 92. 1885. *Psychotria obesa* Wall., *Cat. n.* 8328. 1847, nom. nud. *Uragoga stipulacea* Kuntze, *Revis. Gen. Pl.* 2: 426. 1891, nom. superfl. TYPE: Singapore. *N. Wallich 8328* (holotype, K!; isotype, K!).

Shrubs or trees, 2–5 m tall; branches terete to quadrate, glabrous, 5–10 mm diam.; internodes 4–11 cm, smooth. Leaf blades 20–55 × (7–)9–19 cm, obovate to oblong, apex acuminate to acute, base attenuate to cuneate or sometimes attenuate, drying coriaceous, glabrous, margin flat and with cartilaginous thickening; secondary veins prominulous abaxially, 9 to 13 pairs; domatia absent; petioles 1–10 cm,

furrowed and sometimes with 2 lateral ridges formed by attenuate leaf base. Stipules tubular, funnel-shaped, glabrous to puberulent, drying chartaceous to coriaceous, deciduous via fragmentation, tube 20–50(–75) mm, with ribs 4, broadly winged, arising below petiole and extending to lobes, apex with 2 deep incisions producing 2 broadly oblong sections with acute to rounded apices, lobes 4, 3–4 mm, deltate to narrowly triangular, ciliolate. Inflorescences cymose, many-flowered, terminal on axillary branches or rarely axillary, puberulent; peduncle 2–11 cm; branched portion corymbiform, 2–8 × 3–10 cm, branched to 3 to 5 orders, rather congested; bracts linear to ovate, 0.5–12 mm, glabrous; bracteoles reduced; pedicels absent or to 1 mm. Flowers 5-merous, unisexual. Pistillate flowers: calyx cup-shaped, 2–3 mm wide, outside glabrous or puberulent, with hair-ring inside, truncate; corolla white, clavate in bud, when open salverform, outside glabrous, tube 7–9 mm, 1.5–2 mm diam., inside villous in upper third, lobes 1.8–2.5 mm, ligulate, acute; staminodia included, filaments inserted in lower third of corolla tube, ca. 0.3 mm; style 3–3.5 mm, glabrous, stigmas 1.3–1.5 mm. Staminate flowers: similar to pistillate except corolla tube 7–10 mm, 2–3 mm diam., lobes

2–2.5 mm; anthers included, filaments ca. 0.5 mm; pistillode reduced or absent. *Drupes* violet-black, globose to didymous, 8–10 × 10–12 mm; pyrenes hemispherical or spherical, faintly rugose, deeply fissured, endosperm entire.

Distribution and habitat. This species grows in southeastern Asia, where it is known from Peninsular Malaysia, Singapore, and the Sarawak (Malaysia) sector of Borneo. Here, it can be found in humid forests at elevations of 10–300 m.

Phenology. This species has been collected with flowers January through March and August through December, and with fruits in April.

Discussion. *Gaertnera obesa* is similar to *G. monstrosa* of Madagascar, but can be distinguished by its cylindrical stems, smaller flowers, and stamens and staminodes inserted in the lower third of the corolla tube. Additionally, *G. obesa* is dioecious, whereas *G. monstrosa* is bisexual and distylous. Van Beusekom (1967) noted that the field notes of several collections of *G. obesa* mention that the plants harbored ants. One collection, *Cantley's Collector 3008* (SING), is intermediate between *G. obesa* and *G. grisea* and presumably a natural hybrid.

Representative specimens examined. MALAYSIA. **Johor:** N of Mawai, Panti Forest Reserve, *Malcomber 3025* (MO), *Suppiah KEP 98992* (KEP); Sungai Kayu, *Kiah SING 32110* (BM, K, KEP, SING). **Pahang:** path to Gunong Lesong, Rompin, *Shah 3090* (SING). **Perak:** s. loc., *Ridley 1440* (K). **Sarawak:** Sibui, Ulu Sg. Pasai, Bukit Tanggi, *Yii S 64422* (SAR). SINGAPORE. Singapore Botanic Gardens, Garden Jungle, 7 Mar. 1926, *C. X. D. R. Furtado s.n.* (SING); Upper Peirce Reservoir Nature Reserve, *Malcomber 3007* (MO, SING).

48. *Gaertnera oblanceolata* King & Gamble, J. *Asiat. Soc. Bengal*, Pt. 2, Nat. Hist. 4: 92. 1907. TYPE: Malaysia. Perak: Sungai Luat, *L. Wray, Jr. 2283* (lectotype, designated here, SING!; isotype, G!). Figure 4A–F.

Trees, 1–2.5 m tall, often monocaulous; *branches* terete or quadrangular, glabrous, 2–6 mm diam.; internodes 1.1–7 cm, smooth. *Leaf* blades 11–31 × 4–10 cm, oblanceolate or obovate, apex cuspidate to acuminate, base attenuate to cuneate, drying coriaceous, glabrous or puberulent abaxially on principal veins, margin flat and sometimes thinly cartilaginous; secondary veins prominulous abaxially, 6 to 15 pairs; domatia absent or present; petioles 3–40 mm. *Stipules* tubular, glabrous, drying chartaceous, deciduous, persistent on distalmost nodes or deciduous leaving a persistent base 5–10 mm, tube 11–20 mm, with ribs 4, broadly winged, arising below petiole and extending to lobes, apex entire or with 1 incision, marcescent, lobes 4, 1–3 mm, deltate to linear.

Inflorescences congested-cymose to subcapitate, many-flowered, axillary or paired and supra-axillary, densely puberulent to pilosulose; peduncle 1.5–8 cm; branched portion subglobose or narrowly pyramidal, 2.5–11.5 × 1–6 cm, branched to 2 to 4 orders; bracts deltate or linear, 3–10 mm, sometimes glabrous; bracteoles reduced; pedicels absent or up to 3 mm. *Flowers* 5-merous, unisexual. *Pistillate flowers:* calyx cup-shaped, 1.5–3 mm wide, outside puberulent, with hair-ring inside, truncate or lobes to 0.2 mm, triangular; corolla white, clavate in bud, when open salverform, outside glabrous, tube 4–5 mm, 1.5–2.5 mm diam., inside villous in upper third, lobes 1–1.4 mm, triangular to ligulate, acute; staminodia included, filaments inserted in upper third of corolla tube, ca. 0.3 mm; style 3.5–4 mm, glabrous, stigmas 0.5–0.8 mm. *Staminate flowers:* similar to pistillate except calyx 1.5–2.5 mm wide, outside glabrous or puberulent; lobes ca. 0.3 mm; corolla tube 2.5–4.5 mm, 1–2 mm diam., lobes 1.3–1.7 mm; anthers shortly exerted, filaments 0.2–0.4 mm; pistillode with style portion 2–3.5 mm, stigmatic portions 1–1.5 mm. *Drupes* violet-black, globose or subglobose, 4–6 × 4–8 mm; pyrenes spherical or hemispherical, ± rugose, finely fissured, endosperm entire.

Distribution and habitat. This species grows in southeastern Asia, where it has most commonly been collected in Peninsular Malaysia and is also known from the Sarawak (Malaysia) sector of Borneo. Here, it is found in humid forests at elevations of 30–1500 m.

Phenology. This species has been collected with flowers April through August and in November, and with fruits in August.

Discussion. *Gaertnera oblanceolata* is similar to *G. diversifolia*, but *G. oblanceolata* differs in its subglobose, axillary and supra-axillary inflorescences, versus lax pyramidal inflorescences that are terminal on axillary and supra-axillary branches. *Gaertnera diversifolia* was treated as a variety of *G. oblanceolata* by van Beusekom (1967), one of several species circumscribed more broadly by him than here.

Four syntypes were cited in the protologue: *L. Wray, Jr. 2283* (G!, SING!), *L. Wray, Jr. 1948* (G!), *Scortechini 253* (not located), and *King's Collector 8449* (not located). The first collection is here selected as lectotype because it is more complete and exemplary, and because it has two specimens deposited in different herbaria. The specimen at SING is selected as the lectotype because it is more complete.

Representative specimens examined. MALAYSIA. **Negeri Sembilan:** Pasoh Forest Reserve, *Wong FRI 28905* (KEP), *Wong FRI 2891* (KEP), *Malcomber 3021* (MO), *3022* (MO).

Perak: Bukit Blakang Parang, *Hanift SING 21055* (K, L, SING). **Sarawak:** Miri Distr., Niah National Park, *Malcomber 3039* (MO), *3040* (MO), June 1894, *M. R. Haviland s.n.* (K). **Selangor:** Kanching, Bukit Batu Berdinging, *Nur SING 34357* (A, K, KEP, L, SING).

49. *Gaertnera obovata* Baker, J. Bot. 20: 218. 1882. *Sykesia obovata* (Baker) Kuntze, Revis. Gen. Pl. 2: 425. 1891. TYPE: Madagascar. Chiefly from Betsileo-land, *R. Baron 149* (holotype, K!; isotype, P!). Figure 13A–L.

Trees or shrubs, 1.5–5(–12) m tall; *branches* flattened to quadrangular or terete, glabrous or puberulent, 2–9 mm diam.; internodes 0.3–6.5 cm, smooth or with 2 longitudinal ribs at least when young. *Leaf* blades 1.2–7(–23) × 0.7–8.5 cm, elliptic to oblanceolate, elliptic-obovate, elliptic-oblong, or ovate, apex acute to rounded then abruptly short-acuminate or cuspidate, base acute to obtuse, drying chartaceous, adaxially glabrous, abaxially glabrous or puberulent, margin flat or crisped; secondary veins visible and flat to prominulous, 5 to 16 pairs; domatia absent or present; petioles 2–25 mm. *Stipules* calyptrate, glabrous, drying membranous or chartaceous, caducous or deciduous after distalmost 1 or 2 nodes, tube 8–32 mm, with ribs 4, narrowly winged, arising below petiole and sometimes extending to lobes, apex entire or with 1 incision, lobes 2, 2–3.5 mm, deltate to linear. *Inflorescences* cymose, several- to many-flowered, terminal on principal and/or axillary branches, glabrous or puberulent to pilosulose, sessile or peduncle 0.8–3 cm; branched portion corymbiform to pyramidal, 1.1–12.5 × 1.3–15.5 cm, branched to 3 to 5 orders, lax to congested; bracts deltate to ligulate or trifold, 0.8–40 mm; bracteoles lanceolate to triangular, 1–2 mm; pedicels absent or to 3 mm. *Flowers* 5-merous, heterodistylous. *Long-styled flowers:* calyx cup-shaped, 1.5–3.5 mm wide, outside glabrous or puberulent, sometimes with hair-ring inside, truncate or with lobes 0.1–1.1 mm, triangular; corolla white, pink, or lilac, clavate in bud, when open salverform, outside glabrous, tube 3–7 mm, 1.5–2.5 mm diam., inside villous in upper third, lobes 2–3.5 mm, ligulate to elliptic-oblong, acute; anthers included or shortly exerted, filaments inserted in upper third of corolla tube, 0.3–1 mm; style 3.3–8.2 mm, glabrous, stigmas 0.8–1.6 mm. *Short-styled flowers:* similar to long styled except corolla tube 4–9 mm, 1.7–3.5 mm diam., lobes 2.3–4 mm; anthers shortly exerted, filaments 1.3–3.5 mm; style 2.7–5.2 mm, glabrous, stigmas 1.3–3 mm. *Drupes* violet-black, globose or didymous, 4–10 × 5–10 mm; pyrenes spherical or hemispherical, rugose, finely fissured, endosperm entire.

Distribution and habitat. This species grows in Madagascar, where it is known from the provinces of

Antananarivo, Antsiranana, Fianarantsoa, Mahajanga, Toamasina, and Toliara. Here, it is found in moist forests at elevations of 0–2000 m.

Phenology. This species has been collected with flowers January through March and May through December, and with fruits January through April and October through December.

Discussion. *Gaertnera obovata* is the most commonly encountered *Gaertnera* species within Madagascar, in particular its variety *sphaerocarpa*. The species is distinguished by its generally squared stem; caducous calyptrate stipules; generally elliptic-obovate, obovate, or oblanceolate, acuminate to cuspidate leaves; and terminal cymose inflorescences. This species is similar to *G. guillotii*, but lacks the inflorescence axes often pubescent in lines that are characteristic of that species.

Gaertnera obovata var. *obovata* and variety *sphaerocarpa* are easily distinguished at the extremes of their morphological ranges, but are linked by continuous morphological variation in several characters and thus are not completely distinct. The well-marked, most distinct morphological forms differ markedly in leaf shape, leaf margin, and flower color: variety *obovata* typically has elliptic-oblong to obovate leaves with flat margins and pink to lilac flowers, whereas variety *sphaerocarpa* usually has elliptic-oblong to oblanceolate leaves with crisped margins and white flowers. The current circumscription of these varieties is not entirely satisfactory; these are separated here as outlined below pending additional research.

- 1a. Leaves elliptic to elliptic-oblong, oblanceolate, obovate, or ovate, 1.2–8.5 × 0.7–5.2 cm, with margins flat; corolla pink to lilac or white; long-styled flowers with anthers included; drupes 4–5 × 5–6 mm 49a. variety *obovata*
- 1b. Leaves elliptic-oblong to oblanceolate, 4.5–23 × 1.9–8.5 cm, with margins flat or crisped; corolla white; long-styled flowers with anthers shortly exerted; drupes 6–10 × 5–10 mm
. 49b. variety *sphaerocarpa*

49a. *Gaertnera obovata* Baker var. **obovata.**
Figure 13A–F.

Trees or shrubs 1.5–5(–12) m tall; *branches* flattened to terete, glabrous, 2–3 mm diam.; internodes 0.3–4.5 cm, smooth or with 2 longitudinal ribs at least when young. *Leaf* blades 1.2–7(–8.5) × 0.7–5.2 cm, elliptic to elliptic-oblong, oblanceolate, obovate, or ovate, apex rounded then abruptly shortly acuminate, base acute to obtuse, drying chartaceous, glabrous, margins flat; secondary veins 5 to 8 pairs; petioles 2–10 mm. *Stipules* drying membranous to chartaceous, tube 12–20 mm, lobes 3.2–3.5 mm. *Inflorescences* with peduncle 0.8–3 cm; branched

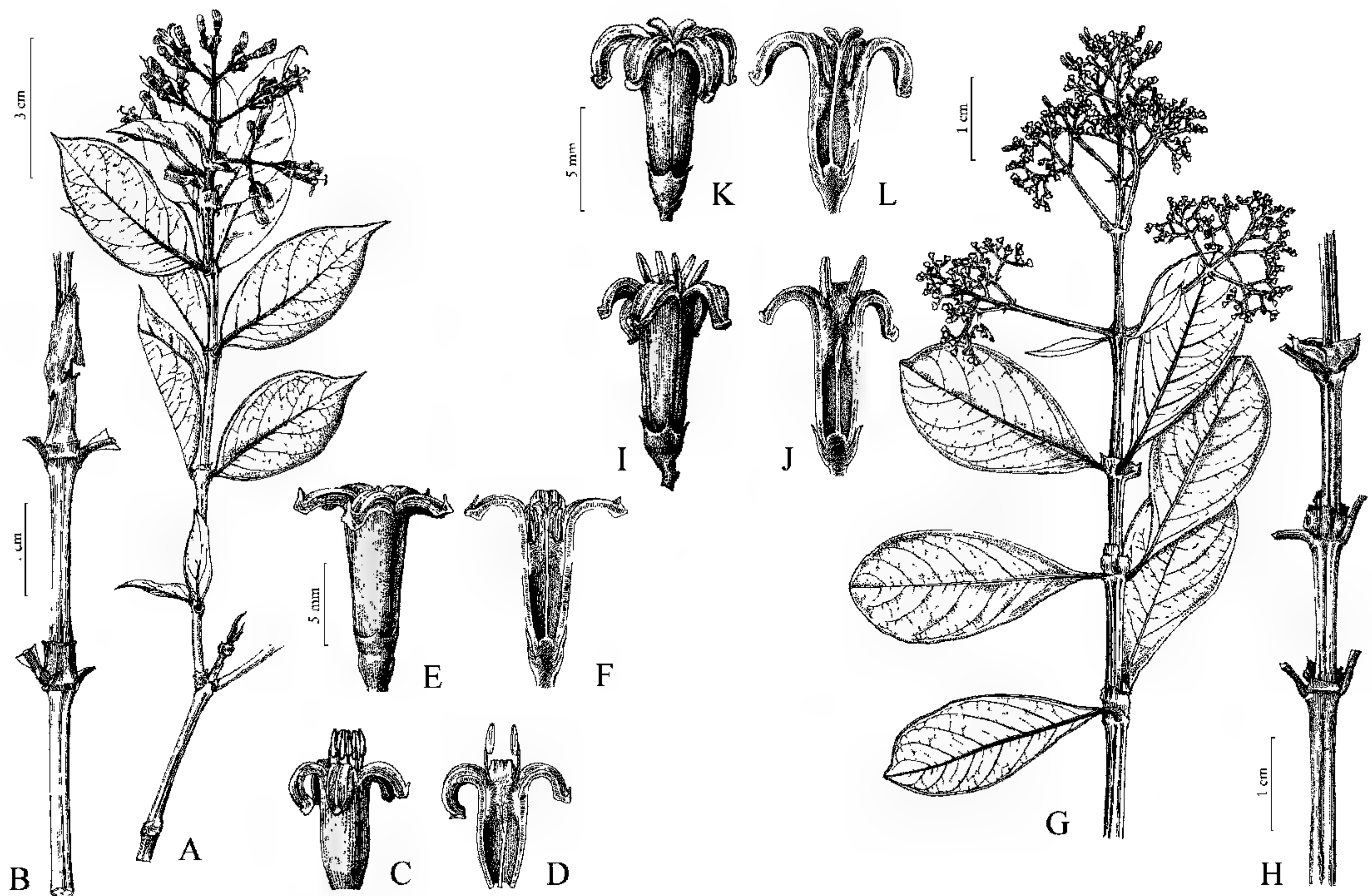

Figure 13. A–F. *Gaertnera obovata* Baker var. *obovata*. —A. Flowering branch (to 3-cm scale). —B. Portion of stem with leaf bases and stipules. —C. Short-styled flower. —D. Short-styled flower in cross section. —E. Long-styled flower. —F. Long-styled flower in cross section. G–L. *Gaertnera obovata* var. *sphaerocarpa* (Baker) Malcomber. —G. Flowering branch. —H. Portion of stem with petiole bases and stipules. —I. Short-styled flower. —J. Short-styled flower in cross section. —K. Long-styled flower. —L. Long-styled flower in cross section. C–F to same 5-mm scale; I–L to same 5-mm scale. A–F based on Malcomber 2882; G–L based on Malcomber 2916.

portion corymbiform, 1.1–5 × 1.3–4.5 cm; bracts 8–27 mm; pedicels absent or to 3 mm. *Long-styled flowers*: calyx 1.5–3.5 mm wide, with hair-ring inside, lobes 0.1–1.1 mm; corolla white to pink or lilac, tube 3.5–7 mm, 1.5–2.5 mm diam., lobes 2–3.5 mm, ligulate to elliptic-oblong; anthers included, filaments 0.3–1 mm; style 5.5–8.2 mm, stigmas 1–1.6 mm. *Short-styled flowers*: corolla tube 4–9 mm, 1.7–3.5 mm diam., lobes 2.5–4 mm, ligulate; filaments 1.3–1.7 mm; style 2.8–5.2 mm, stigmas 1.7–3 mm. *Drupes* 4–5 × 5–6 mm; pyrenes hemispherical.

Distribution and habitat. This variety grows in Madagascar, where it is known from the provinces of Antananarivo, Antsiranana, Fianarantsoa, Mahajanga, and Toamasina. Here, it is found in moist forests at elevations of 10–2000 m.

Phenology. This variety has been collected with flowers January through March and May through December, and with fruits January through March and October through December.

Representative specimens examined. MADAGASCAR. **Antananarivo:** 5.7 km ESE of Anjozorobe, Malcomber 2838 (MO, TEF); Ambohitantely Special Reserve, Bernardi

11097 (A, BR, G, P); Manjakandriana, Ambatolaona, Rakoto RN 1487 (P). **Antsiranana:** Anjanaharibe-Sud Special Reserve, Lewis 1306 (K, MO, P, TAN); Marojejy Nature Reserve, Malcomber 2776 (MO), 2793 (MO), 2799 (MO); lower valley of Androranga River, near Antongondriha, Mt. Anjenabe, Humbert 24117 (P); Manongarivo Nature Reserve, Schatz 3211 (MO, P, TAN), Malcomber 1460 (K, MO, TAN), 2786 (MO); Tsaratanana Nature Reserve, Humbert 18201 (P). **Fianarantsoa:** Andrambovato, Capuron SF 255 (MO); Andringitra Integral Reserve, Lewis 1030 (K, MO, P, TAN); Antoetra, Jongkind 878 (K, MO, P, TAN); Ranomafana National Park, Malcomber 106 (BR, G, K, MO, P, PRE, TAN, WAG), 2869 (MO, TEF), 2881 (MO), 2882 (MO, TEF). **Mahajanga:** Bealanana, R.-J. Dufournet s.n. (P). **Toamasina:** Ambatoloana, Benoist 297 (P, TAN); 6.6 km SE of Andasibe, Andriandavibe, Malcomber 2926 (MO, TEF); Lac Aloatra, Mt. Ankaraka, Humbert 17480 (P); Mantadia National Park, Nicoll 170 (MO); Masoala National Park, Andranobe, Malcomber 2819 (MO).

49b. *Gaertnera obovata* var. *sphaerocarpa* (Baker) Malcomber, comb. et stat. nov. Basionym: *Gaertnera sphaerocarpa* Baker, J. Linn. Soc., Bot. 20: 208. 1883. *Sykesia sphaerocarpa* (Baker) Kuntze, Revis. Gen. Pl. 2: 425. 1891. TYPE: Madagascar. Central Madagascar, R. Baron 1243 (lectotype, designated here, K!; isotype, P!). Figure 13G–L.

Trees 1.5–12 m tall; *branches* flattened or quadrangular to terete, glabrous or puberulent, 3–9 mm diam.; internodes 1.8–6.5 cm, smooth. *Leaf* blades 4.5–23 × 1.9–8.5 cm, oblanceolate to elliptic-oblong, apex acute to rounded then abruptly shortly cuspidate, base acute to cuneate, drying chartaceous, adaxially glabrous, abaxially glabrous or puberulent, margin flat or crisped; secondary veins 5 to 10(to 16) pairs; petioles 3–25 mm. *Stipules* drying membranous, tube 8–25(–32) mm, lobes 2–3 mm. *Inflorescences* sessile or peduncle to 2.5 cm; branched portion corymbiform to pyramidal, 3.5–8.5(–12.5) × 6.5–12(–15.5) cm; bracts 0.8–40 mm; pedicels absent or to 2 mm. *Long-styled flowers*: calyx 1.5–2.5 mm wide, glabrous or with hair-ring inside, truncate or with lobes to 0.5 mm, triangular; corolla white, tube 3–5.5 mm, 2–2.5 mm diam., lobes 2.1–2.4 mm, ligulate; anthers shortly exerted, filaments 0.3–0.5 mm; style 3.3–5.8 mm, stigmas 0.8–1.4 mm. *Short-styled flowers*: similar to long styled except calyx 1.7–2.2 mm; corolla tube 4–6 mm, 1.7–2.5 mm diam., lobes 2.3–2.6 mm; filaments 1.4–3.5 mm; style 2.7–3.5 mm, stigmas 1.3–2.5 mm. *Drupes* 6–10 × 5–10 mm; pyrenes spherical or hemispherical.

Distribution and habitat. This variety grows in Madagascar, where it is known from the provinces of Antananarivo, Antsiranana, Fianarantsoa, Toamasina, and Toliara. Here, it grows in moist forests at elevations of 0–1600 m.

Phenology. This variety has been collected with flowers in January and July through December, and with fruits January through April and in December.

Discussion. This variety is similar to *Gaertnera macrobotrys*; see additional comments under that species.

Two syntypes were cited in the protologue: *R. Baron 1233* (K!, P!) and *R. Baron 1243* (K!, P!). The latter is selected as lectotype here because it is a more complete and exemplary specimen. The specimen at K is selected as the lectotype because the author of the name worked there.

Representative specimens examined. MADAGASCAR. **Antananarivo:** 5.7 km ESE of Anjozorobe, *Malcomber 2836* (MO, TEF), *2837* (MO, TEF). **Antsiranana:** Andapa, Lokoho Basin, Ankobahina Hills, *Humbert 22019* (MO, P); Marojejy Nature Reserve, *Malcomber 2783* (MO, TEF), *2788* (MO, TEF), *2789* (MO). **Fianarantsoa:** Andrambovato, *Humbert 28500* (MO, P); Farafangana, Ivongo, *Rakotovao 593* (TEF), *607* (TEF); Ranomafana National Park, Vohiparara, *Malcomber 2857* (MO, TEF), *2859* (MO, TEF); W of Ambositra, Itremo Massif, *Malcomber 2839* (MO, TEF), *2840* (MO, TEF). **Toamasina:** near Andasibe, Mantadia National Park, *Birkinshaw 296* (MO), *Malcomber 2917* (MO), *2918* (MO, TEF), *2919* (MO, TEF), *2928* (MO, TEF), *2929* (MO, TEF); Analamay rd., *Rakotomalaza 1317* (MO, TAN); Didy, Brickaville, *Cours 4790* (MO, P). **Toliara:** Andohahela Massif, Ranohela Valley, *Humbert 6250* (MO, P); Beampin-

gartra Massif, Maloto Valley, *Humbert 6322* (MO, P); Fort Dauphin, Mandena, *Bosser 14413* (TAN).

50. *Gaertnera paniculata* Benth., Niger Fl. 459. 1849. *Sykesia paniculata* (Benth.) Kuntze, Revis. Gen. Pl. 2: 425. 1891. TYPE: Nigeria. Grand Bassa, *S. Vogel 71* (lectotype, designated here, K!).

Gaertnera occidentalis Baill., Bull. Mens. Soc. Linn. Paris 1: 235. 1880. TYPE: Gabon. s. loc., *G. du Bellay et al. 232* (holotype, P!).

Trees or shrubs, (1.2–)2–9 m tall; *branches* flattened to terete, when young glabrous or puberulent, becoming glabrescent, 2–6 mm diam.; internodes 2–8 cm, smooth or with a low ridge. *Leaf* blades 8–18 × 3–9 cm, elliptic to elliptic-oblong or oblanceolate, apex shortly cuspidate or acuminate, base cuneate to obtuse, drying chartaceous, adaxially glabrous, abaxially glabrous or sparsely pilosulose to hirtellous on principal veins; secondary veins prominent abaxially, 3 to 8 pairs; domatia absent or present; petioles 5–17 mm. *Stipules* tubular, glabrous, drying chartaceous, caducous, persisting on distalmost 1 to 3 nodes or deciduous leaving persistent base 1–5 mm, tube 8–20 mm, with ribs 4, narrowly winged, arising below petiole and extending to lobes, apex entire, marcescent, lobes 4, 0.5–1.2 mm, deltate to narrowly triangular. *Inflorescences* cymose to paniculiform, many-flowered, terminal on principal and/or axillary branches, densely puberulent to glabrescent or pilosulose, sessile or peduncle to 8 cm; branched portion corymbiform or narrowly pyramidal, 7–20 × 4–25 cm, branched to 4 to 6 orders, lax; bracts deltate or trifid, 1–2.2 mm, sometimes glabrous; bracteoles reduced; pedicels absent or to 0.3 mm. *Flowers* 5-merous, heterodistylous. *Long-styled flowers*: calyx cup-shaped, 1.2–2 mm wide, glabrous or puberulent outside, with hair-ring inside, truncate or lobes to 1 mm, triangular; corolla white, clavate in bud, when open salverform, outside densely puberulent, tube 3–4 mm, 1–2.5 mm diam., inside villous in upper third, lobes 1.5–2.5 mm, ligulate to linear, acute; anthers shortly exerted, filaments inserted in upper third of corolla tube, ca. 0.3 mm; style 6–7 mm, glabrous or pubescent in upper part, stigmas 0.5–1.5 mm. *Short-styled flowers*: similar to long styled except corolla outside tomentulose or puberulent, tube 2.5–4 mm, lobes 1.5–2 mm, ligulate; anthers fully exerted, filaments 2–2.5 mm; style 1.5–2 mm, stigmas 0.7–1 mm. *Drupes* violet-black, globose or subglobose, 7–9 × 6–9 mm; pyrenes spherical or hemispherical, ± rugose, finely fissured, endosperm entire.

Distribution and habitat. This species grows in West and Central Africa, where it is widespread and

known from Angola, Benin, Burkina Faso, Cameroon, the Central African Republic, the Democratic Republic of the Congo, Gabon, Ghana, Guinea, Côte d'Ivoire, Liberia, Mali, Nigeria, the Republic of the Congo, Senegal, Sierra Leone, Togo, and Zambia. Here, it is found in humid forests at elevations of 0–1720 m.

Phenology. This species has been collected with flowers and fruits throughout the year.

Discussion. *Gaertnera paniculata* is similar to *G. vaginans* and *G. longivaginalis*, but differs in its externally densely puberulent or tomentulose corolla tubes. This is the most commonly collected species of *Gaertnera* in Africa.

Two syntypes were cited in the protologue of *Gaertnera paniculata*, *S. Vogel* 70 (K!) and *S. Vogel* 71 (K!). The latter is selected as lectotype here because it is a more complete and exemplary specimen.

Representative specimens examined. ANGOLA. Dundo, *Gossweiler* 14108 (K); Estrada, *Raimundo* 2846 (BR). BENIN. Natitingau, *Aubréville* 81 (P); Tohoué, Porto-Novo, *Chevalier* 22774 (P). BURKINA FASO. Guenako, *Toutain* 2408 (P). CAMEROON. 17 km S of Meiganga, *W. de Wilde* 3945 (WAG); Rocher du Loup, *Lowe* 3623 (FHO, K, P). CENTRAL AFRICAN REPUBLIC. Bouar, *Audru* 29996 (P); near Mbanza, Km 15 Nola-Salo rd., *Leeuwenberg* 7106 (BR, K, P, WAG). DEMOCRATIC REPUBLIC OF THE CONGO. Eala, *Corbisier* 1266 (FHO, K, P, WAG); Kiri, Lac Leopold, *Goossens* 6208 (BR); Madimba, Mpese, *Germain* 2067 (P, WAG). GABON. **Haut-Ogooué:** Km 23 Moanda-Franceville rd., *Breteler* 6275 (BR, MO, P, WAG). **Ogooué-Lolo:** Lastoursville, Boucimbi, *Le Testu* 8642 (BM, MO, P). GHANA. Hahoe, Togo Plateau FR, *St. Clair-Thompson* 3586 (E, FHO, MO). GUINEA [GUINEA-CONAKRY]. Friguiaigbé, Mayou-Dowie, *Chillou* 800 (MO, P); Mt. Nimba, *Schnell* 1123 (P). IVORY COAST [CÔTE D'IVOIRE]. Aplati, Boudoukou, *Aubréville* 733 (P); near Grand Bassam, Aboisso, *Breteler* 5974 (MO, P, WAG, WU). LIBERIA. 5 mi. Monrovia, Monrovia-Bopulu rd., *Van Meer* 121 (MO, WAG); Sinoe to port, *Jansen* 1119 (MO, WAG). MALI. Ngolokounadougou, Farako, *Raynal* 21012 (MO, P). NIGERIA. Akpaka Reserve, Onitsha, *Okeke* FHI 38440 (FHO, P, WAG); Eket, Aron-Eket rd., *Talbot* 3005 (BM); Gongola, Mambilla, Akwaijantan, *Chapman* 5247 (FHO, K). REPUBLIC OF THE CONGO. Brazzaville, *Chevalier* 11206 (P); La Lifoula, *de Néré* 1355 (P, WAG); Stanley Pool, *Schlechter* 12549 (BR, G, G-DC, L, P). SENEGAL. s. loc., *Perrottet* 413 (G-DC). SIERRA LEONE. Mt. Loma, *Jaeger* 7688 (G, WAG); Sherbro Island, *Hunter* 28 (BM). TOGO. Kloto, *Pisch* 7692 (MO, WAG). ZAMBIA. Mwinilunga, *White* 3311 (BM, BR, FHO, K, WAG).

51. *Gaertnera pauciflora* Malcomber & A. P. Davis, *Monogr. Syst. Bot. Missouri Bot. Gard.* 104: 392, figs. 5, 7. 2005. TYPE: Madagascar. Antsiranana: Marojejy Nature Reserve, 1300–1500 m, 19 Sep. 1997, *S. T. Malcomber* 2781 (holotype, MO-5714904!; isotypes, A!, BR!, G!, K!, LE!, MAL!, MAU!, MO-5714903!, P!, PRE!, TEF!, WAG!).

Trees or shrubs, 1.5–6 m tall; *branches* flattened to terete, glabrous, 1–3 mm diam., with bark becoming gray-white; internodes 0.4–2.6 cm, smooth or with 2 low longitudinal ridges. *Leaf* blades 1–3 × 0.4–1.5 cm, elliptic to elliptic-oblong or oblanceolate, apex shortly cuspidate or acute, base acute to usually cuneate, drying chartaceous, glabrous; secondary veins visible and flat to prominulous abaxially, 4 to 6 pairs; domatia absent or present; petioles 1.5–3 mm. *Stipules* calyptrate, glabrous, drying membranous, caducous, tube 7–21 mm, with ribs 4, narrowly winged only beneath petiole, apex with 1 or 2 incisions, lobes 2 or 4, ca. 0.5 mm, deltoid to filiform. *Inflorescences* reduced to 1 flower or 2-flowered and fasciculate, terminal on axillary branches or axillary, glabrous; peduncle 2.5–9.1 mm, often articulated in upper half; bracteoles elliptic to ovate, 1–4 mm. *Flowers* 4(5)-merous, heterodistylous. *Long-styled flowers:* calyx cup-shaped, 1–2 mm wide, glabrous, truncate or lobes 0.2–0.4 mm, broadly triangular; corolla white, clavate in bud, when open salverform, outside glabrous, tube 4–7.5 mm, 2.5–3 mm diam., inside glabrous, lobes 6–8 mm, ligulate to linear, acute; anthers included, filaments inserted in lower third of corolla tube, 0.2–1 mm; style 5–6 mm, glabrous, stigmas 0.5–1 mm. *Short-styled flowers:* similar to long styled except calyx 2.2–2.8 mm wide, lobes 0.1–0.3 mm; corolla tube 5–7.5 mm, 2.5–3 mm diam., lobes 6–7 mm; filaments 1.5–2.5 mm; style 1.8–2.5 mm, stigmas 0.5–1.2 mm. *Drupes* violet-black, subglobose to didymous, 6–7 × 5–7.5 mm; pyrenes spherical or hemispherical, ± rugose, finely fissured, endosperm entire.

Distribution and habitat. This species grows in Madagascar, where it is known from the provinces of Antsiranana and Fianarantsoa. Here, it is found in humid evergreen forests on metamorphic and igneous rocks at elevations of 750–1800 m.

Phenology. This species has been collected with flowers January through March and September through December, and with fruits January through March and October through December.

Discussion. *Gaertnera pauciflora* can be separated from the other few-flowered *Gaertnera* species in Madagascar by its smooth or only slightly ridged internodes, lack of pubescence, calyptrate stipules, and subtruncate to denticulate calyx. Malcomber and Davis (2005) considered the conservation status of this species to be Endangered (IUCN, 2001).

Representative specimens examined. MADAGASCAR. **Antsiranana:** E of Andapa, Marojejy Nature Reserve (RNI #12), above camp 3 summit trail, *Malcomber* 2779 (MO,

TEF), 2780 (MO, TEF). **Fianarantsoa:** Ifanadiana–Tolon-goina, Mangalanihelatra, Namorona River, *Capuron SF 23220* (P).

52. *Gaertnera pendula* Bojer, Hortus Maurit. 217. 1837. *Sykesia pendula* (Bojer) Kuntze, Revis. Gen. Pl. 2: 425. 1891. TYPE: Mauritius. Montagne de Pouce, *W. Bojer s.n.* (holotype, P not located; isotype, G-DC!).

Gaertnera lanceolata Bouton ex A. DC., Prodr. 9: 33. 1845, non *Gaertnera lanceolata* Ridl., 1915. TYPE: Mauritius. La Nouvelle Decouverte, *L. S. Bouton s.n.* (holotype, G-DC!; isotype, K!).

Gaertnera oxyphylla Drake, Bull. Soc. Bot. France 45: 354. 1899, hom. illeg., non *Gaertnera oxyphylla* Benth., 1857. TYPE: Madagascar. s. loc., *L. A. Chapelier s.n.* (holotype, P!).

Trees or shrubs, 1.5–4.5 m tall; *branches* flattened to terete, glabrous, 2–4 mm diam.; internodes 0.8–8 cm, smooth. *Leaf* blades 4.5–17 × 2–8 cm, elliptic to ovate or oblanceolate, apex shortly cuspidate or acuminate, base acute to obtuse or rounded, drying chartaceous to subcoriaceous, glabrous; secondary veins prominulous abaxially, 5 to 10 pairs; domatia absent or present, often crypt-type; petioles 3–45 mm. *Stipules* tubular, glabrous, drying chartaceous, caducous or quickly deciduous through fragmentation, tube 18–20 mm, with ribs 4, narrowly winged, arising below petiole and extending to lobes, apex with 1 or 2 incisions, marcescent, lobes 4, 1–3.3 mm, deltoid or filiform. *Inflorescences* cymose, many-flowered, terminal on flexuous axillary branches, glabrous or puberulent; peduncle 3.5–9(–13) cm, flexuous; branched portion corymbiform, 1.8–3.5 × 1.5–3.3 cm, branched to 2 to 3 orders, lax to somewhat congested; bracts trifold, 3–12 mm; bracteoles triangular, 1–2 mm; pedicels absent or to 1.5 mm. *Flowers* 5-merous, heterodistylous. *Long-styled flowers:* calyx campanulate, 1.5–3 mm wide, puberulent to glabrous outside, glabrous inside, lobes 1.5–3.5 mm, narrowly triangular or oblong-spatulate; corolla white or pale blue, clavate in bud, when open salverform, outside glabrous, tube 16–24 mm, 2–3.5 mm diam., inside glabrous, lobes 8–9 mm, ligulate or elliptic-oblong, acute; anthers included, filaments inserted in upper third of corolla tube, to 0.5 mm; style 18–19 mm, glabrous, stigmas 2.5–3 mm. *Short-styled flowers:* similar to long styled except calyx sparsely pubescent outside; corolla tube 20–25 mm, 3.5–4 mm diam., lobes 8–10 mm, ligulate or ovate-oblong; anthers shortly exerted, filaments 0.5–1 mm; style 9–10 mm, stigmas 3.5–3.7 mm. *Drupes* black (Bojer, 1837) or violet-black, ellipsoid or fusiform, 20–25 × ca. 10 mm; pyrenes plano-convex, rugose, finely fissured, endosperm entire.

Distribution and habitat. This species grows in Mauritius and may also grow in Madagascar, but that report is based on an old, poorly documented specimen and seems doubtful. On Mauritius, this species is found in wet to very wet forests at elevations of 50–650 m.

Phenology. This species has been collected with flowers in January, February, and October through December, and with fruits in June.

Discussion. The collections of *Gaertnera pendula* attributed to Madagascar appear to have inaccurate labels. This species can be recognized by its pendulous inflorescences borne at the ends of long flexuous branches, white or pale blue flowers, and ellipsoid or fusiform fruits. This is the only *Gaertnera* species reported to have blue flowers.

Representative specimens examined. MADAGASCAR. s. loc., *L. S. Bouton s.n.* (K). MAURITIUS. Mt. Cocotte, *Coode 4824* (K), *Page 226* (MAU); Mt. Pouce, *Bojer 68* (W); Mt. Savanne, *Friedmann 2984* (P); Black River Gorges National Park, *Malcomber 2933* (MO), *2936* (MO); in Pidgeon wood opposite Les Mares, *Page 94* (MAU).

53. *Gaertnera phanerophlebia* Baker, J. Linn. Soc., Bot. 21: 425. 1885. *Sykesia phanerophlebia* (Baker) Kuntze, Revis. Gen. Pl. 2: 425. 1891. TYPE: Madagascar. Central Madagascar, *R. Baron 2982* (lectotype, designated here, K!; isotypes, BM!, P!). Figure 11G–M.

Gaertnera crinita Drake, in Grandid., Hist. Phys. Madagascar 36(6), Atlas 4: t. 432. 1897 [1898], syn. nov. TYPE: Madagascar. [Île] Sainte Marie, 1850 (fl.), *L.-H. Boivin 1780* (lectotype, designated here, P!; isotype, MO!).

Shrubs and trees, 3–8 m tall; *branches* flattened to terete, pilose to hirsute (glabrous) with indumentum drying red-brown, 1.5–5 mm diam.; internodes 1.7–8.5 cm, smooth. *Leaf* blades 2.5–12.5 × 1–3.5 cm, elliptic-oblong to oblanceolate, apex acute to acuminate, base obtuse to truncate, drying chartaceous, adaxially glabrous or densely strigose on costa and sometimes secondary veins and occasionally sparsely hispid on blade, abaxially densely strigose to hirsute (glabrous) on principal veins to throughout; secondary veins prominulous abaxially, 6 to 14 pairs; domatia absent; petioles 1–7 mm. *Stipules* calyptrate, densely hirsute or strigose (glabrous), drying membranous, caducous, tube 11–30 mm, without ribs, with narrow wings only developed below petiole, apex with 1 or 2 incisions, marcescent, lobes 2, 0.5–2 mm, deltate. *Inflorescences* subcapitate to congested-cymose, many-flowered, terminal on principal and/or axillary branches, densely pilose to strigose (glabrous), sessile or peduncle to 4.3 cm; branched portion subglobose or corymbiform, 0.7–4.5 × 1–8.5 cm, branched to 2 to

4 orders, congested; bracts deltate to linear, 4–20 mm; bracteoles 1–2 mm; pedicels absent or to 3 mm. *Flowers* 5-merous, heterodistylous. *Long-styled flowers*: calyx cup-shaped, 1.5–4.2 mm wide, outside glabrous or pilosulose to strigose, glabrous inside, lobes equal to unequal, 2–5 mm, linear to narrowly triangular; corolla white, clavate in bud, when open salverform, outside pilose to pilosulose (glabrous), tube 9.5–17 mm, 2–4.5 mm diam., inside villous at ca. middle or in upper third, lobes 1.5–6 mm, triangular or ligulate, acute; anthers included, filaments inserted at ca. middle of corolla tube, ca. 0.4 mm; style 9.5–16.5 mm, glabrous, stigmas 1.4–3 mm. *Short-styled flowers*: similar to long styled except calyx 1.5–3.5 mm wide, outside pubescent to pilose or glabrous, lobes 5–13.9 mm, triangular to linear; corolla tube 1.8–4.5 mm diam., lobes 1.7–5 mm, filaments inserted in upper third of corolla tube, 1.2–3.5 mm; style 4.4–7.2 mm, stigmas 1.5–3.6 mm. *Drupes* violet-black, subglobose or didymous, 6–9 × 6–9 mm; pyrenes spherical or hemispherical, rugose, finely fissured, endosperm entire.

Distribution and habitat. This species grows in Madagascar, where it is known widely through the northeastern region. Here, it is frequent in wet forests at elevations of 50–1650 m.

Phenology. This species has been collected with flowers January through March and June through December, and with fruits January through March and August through December.

Discussion. *Gaertnera phanerophlebia* is a distinctive species that can be recognized by its subglobose to corymbiform, congested-cymose to subcapitate inflorescences, well-developed narrow calyx lobes, reddish brown to chestnut drying color, and usually dense indumentum. Occasionally, plants are glabrous but otherwise match this species (e.g., *McPherson & van der Werff 16360*, MO) and are included here; such variation in pubescence is found in some other species of Rubiaceae. This species is similar to *G. hispida*; see additional comments under that section of this paper.

The protologue of *Gaertnera crinita* does not discuss the comparison or contrast of this species with the similar species *G. phanerophlebia*, so it is unknown if Grandidier was familiar with *G. phanerophlebia*. The figure in the protologue of *G. crinita* shows both flowers and fruits, and matches plants included here in *G. phanerophlebia* in all details; accordingly, these names are synonymized here. No specimen was mentioned in *G. crinita*'s protologue, but several specimens are annotated with this name at P. These generally match the figure and are all identified as

Boivin 1780 with the flowering collections recorded as collected in 1850 and the fruiting collections in 1849. No other collections were found annotated with this name. Because the fruits of most *Gaertnera* species are similar, the flowering specimens that show all the features that distinguish this species and are dated 1850 are chosen as the lectotype. The specimen at P is chosen as the lectotype because the author of the name worked at that institution, and the specimen deposited at MO was distributed only recently.

Two syntypes were cited in the protologue of *Gaertnera phanerophlebia*, *R. Baron 2372* (K!, P!) and *R. Baron 2982* (BM!, K!, P!). The latter is selected here as lectotype because it is a more complete and exemplary specimen with more duplicates. The specimen at K is chosen as the lectotype because the author of the name worked at that institution.

Gaertnera phanerophlebia apparently hybridizes with some other *Gaertnera* species. In particular, one specimen, *P. J. Rakotomalaza et al. 2068* (Madagascar, Majunga, 1200 m, MO), seems to represent a hybrid between *G. phanerophlebia* and either *G. humblotii* or *G. raphaelii*.

Representative specimens examined. MADAGASCAR. **Antsiranana:** Manongarivo Nature Reserve, Ansatroto, *Gautier & Chatelain 2817* (G, MO, P); Ambodisakoano, *G. McPherson & van der Werff 16360* (MO, TAN); Massif Bekolosy, *Gachet SF 7531* (TEF); Marojejy Nature Reserve, *Humbert 22283* (P), *31467* (MO, P), *31669* (MO, P), *Miller & Randrianasolo 4488* (MO). **Toamasina:** Analalva, W of Foulpointe, *Capuron SF 23845* (P); Anjanaharimbe-Sud Reserve, Antsavokabe, *Ravelonarivo 903* (MO, P, TAN); Didy, Brickaville, *Cours 4893* (P); Île Saint-Marie, *Boivin 1780* (G-DC, MO, P); Vohimarongitra Reserve, *Rakotoniaina RN 2448* (MO); Zahamena National Park, *Humbert 17618* (P), *Botoalina RN 3192* (MO, TAN).

54. *Gaertnera phyllosepala* Baker, J. Linn. Soc., Bot. 20: 207. 1883. *Sykesia phyllosepala* (Baker) Kuntze, Revis. Gen. Pl. 2: 425. 1891. TYPE: Madagascar. Central Madagascar, *R. Baron 1920* (holotype, K!; isotype, P!). Figure 14A–F.

Trees, 1.5–8 m tall; *branches* flattened to terete or subquadrate, when young densely hispidulous to strigose or pilose with indumentum drying yellow to gray, when older, trichomes often breaking off leaving prominent persistent basal portions, 3–7 mm diam.; internodes 2–8.5 cm, smooth. *Leaf* blades 6.5–20.5 × 2.5–7.5 cm, lanceolate to elliptic, oblanceolate, or elliptic-oblong, apex shortly acuminate, base rounded to truncate or cordulate, drying chartaceous, adaxially glabrous except pilosulose to pilose on costa and sometimes secondary veins, abaxially pilose or pilosulose with indumentum denser on principal veins; secondary veins prominent abaxially, 9 to 12 pairs; domatia absent; petioles 3–11 mm. *Stipules*

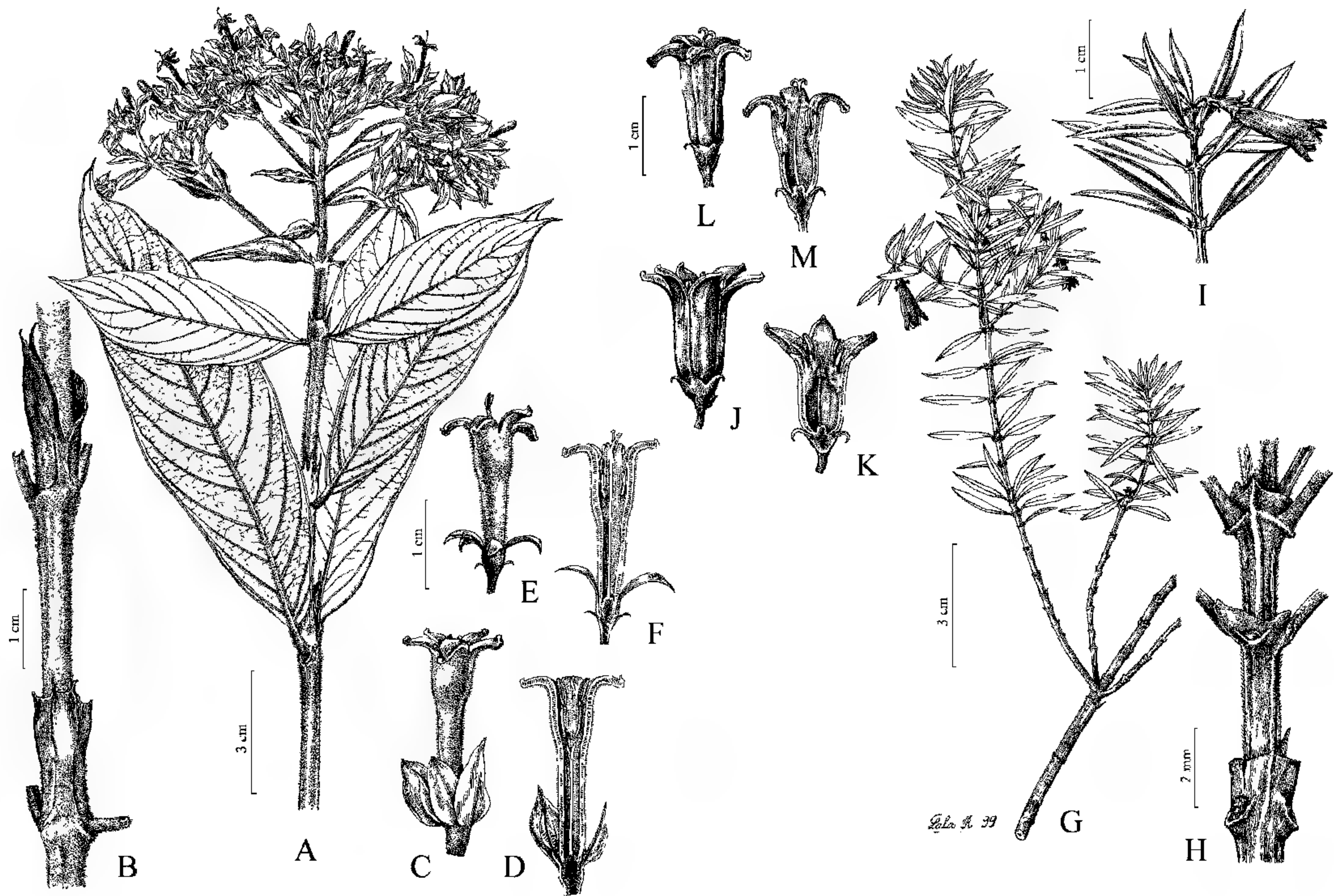

Figure 14. A–F. *Gaertnera phyllosepala* Baker. —A. Flowering branch. —B. Portion of stem with petiole bases and stipules. —C. Short-styled flower. —D. Short-styled flower in cross section. —E. Long-styled flower. —F. Long-styled flower in cross section. G–M. *Gaertnera ternifolia* Thwaites. —G. Flowering branch. —H. Portion of stem with petiole bases and stipules. —I. Portion of flowering branch. —J. Short-styled flower. —K. Short-styled flower in cross section. —L. Long-styled flower. —M. Long-styled flower in cross section. C–F to same 1-cm scale; J–M to same 1-cm scale. A–F based on *Moise 6*; G–M based on *Malcomber 2767*.

tubular, pilose to hirsute or strigose, drying chartaceous, persistent at least on distalmost several nodes, tube 8–21 mm, with ribs 4, narrowly winged, arising below petiole and sometimes extending to lobes; apex with 1 or 2 incisions, marcescent, lobes 4, 2–6 mm, deltate to linear. *Inflorescences* cymose, many-flowered, terminal on axillary branches, pilosulose to pilose; peduncle 1.8–8 cm; branched portion corymbiform, 4.5–14 × 3–19 cm, branched to 3 to 5 orders, lax or somewhat congested; bracts lanceolate to elliptic or ovate, 5–30 mm, white, sometimes glabrous; bracteoles 5–10 mm, white; pedicels absent or to 3 mm. *Flowers* 5-merous, heterodistylous. *Long-styled flowers*: calyx cup-shaped or campanulate, 2.4–3 mm wide, outside densely pilosulose or puberulent, glabrous inside, lobes ca. equal in size or 1 lobe larger, 5–9.4 mm, narrowly lanceolate to elliptic or ovate, white; corolla white, clavate in bud, when open infundibuliform or salverform, outside densely pilosulose or puberulent, tube 14–16 mm, 1.5–4 mm diam., inside glabrous, lobes 4–6 mm, triangular to ligulate, acute; anthers included, filaments inserted in upper third of corolla tube, 0.3–0.7 mm; style 14–

16.5 mm, glabrous, stigmas 1.5–2.5 mm. *Short-styled flowers*: similar to long styled except calyx 2–3 mm wide, lobes 6.5–13 mm, lanceolate or elliptic; corolla tube 15–22 mm, 1.5–4.5 mm diam., lobes 2.5–6 mm, acute; filaments 2–3.5 mm; style 8.5–11 mm, stigmas 2.5–3.5 mm. *Drupes* violet-black, subglobose or didymous, 6–7 × 7–8 mm; pyrenes spherical or hemispherical, rugose, finely fissured, endosperm entire.

Distribution and habitat. This species grows in Madagascar, where it is known from the provinces of Antsiranana, Fianarantsoa, and Toamasina. Here, it is found in humid forests at elevations of 0–1200 m.

Phenology. This species has been collected with flowers in January, February, and October through December, and with fruits January through May and in December.

Discussion. *Gaertnera phyllosepala* is an attractive and commonly encountered species with showy, well-developed white calyx lobes and bracts. This species is similar to *G. phyllostachya*; *G. phyllosepala* can be recognized by its densely hispidulous to strigose or

pilose branches, tubular stipules, shorter calyx lobes and bracteoles, 5–10 mm long, and regularly lobed calyx limbs with the lobes rounded to obtuse or shortly acuminate, versus glabrous to puberulent branches, calyptrate stipules, calyx lobes and bracteoles 6–16 mm long, and truncate or 1- to 3-lobed calyx limbs with the lobes sharply acute in *G. phyllostachya*.

Representative specimens examined. MADAGASCAR. **Antsiranana:** Antalaha, Ampanavoana, *Ranjokiny RN-10845* (P). **Fianarantsoa:** Anosy-Manakara, *Unknown Collector SF 13604* (P, TEF). **Toamasina:** Brickaville, *Croat 32613* (MO, TAN), *D'Arcy 15273* (MO, P); Mananara-Nord National Park, *Malcomber 2910* (MO, TEF), *Raharimalala 193* (P); Masoala National Park, Andranobe, *Malcomber 2814* (MO, TEF), *Schatz 1348* (MO, P, TAN, WAG), *3080* (MO, P, TAN), *Van Nek 2107* (TAN), *Zjhra 133* (MO, P, TAN); Soanierana-Ivongo, Fenerive, *Unknown Collector SF 1058* (P, TAN, TEF); Zahamena (RNI 3), *Botoalina RN 607* (MO), *Decary 16786* (P).

55. *Gaertnera phyllostachya* Baker, J. Linn. Soc., Bot. 21: 425. 1885. *Sykesia phyllostachya* (Baker) Kuntze, Revis. Gen. Pl. 2: 425. 1891. TYPE: Madagascar. s. loc., *R. Baron 2327* (lectotype, designated here, K!).

Trees, 5–10 m tall; branches terete to flattened or subquadrangular, when young glabrous or puberulent at least near nodes with indumentum drying yellow, becoming glabrescent, 2–4 mm diam.; internodes 2–7 cm, smooth. Leaf blades 3.5–15(–17) × 1–5.5(–8) cm, elliptic to oblanceolate or oblong, apex obtuse then shortly cuspidate or acuminate, base attenuate or cuneate (truncate), drying chartaceous to subcoriaceous, glabrous or pilosulose along midrib abaxially; secondary veins prominulous abaxially, 5 to 7(to 12) pairs; domatia absent or present, pilosulose to deep crypt-type; petioles 4–8 mm. Stipules calyptrate, glabrous to densely pilosulose or puberulent, drying membranous, caducous, deciduous through fragmentation, or occasionally persistent, tube 10–35(–55) mm, with ribs 4, narrowly winged, arising beneath petiole and sometimes extending to apex, apex with 1 incision, lobes 1 or 2, 1–2 mm, deltate to linear. Inflorescences cymose, many-flowered, terminal on axillary branches, puberulent; peduncle 1.4–4.5 cm; branched portion corymbiform, 2–10(–20) × 2.7–18.5 cm, branched to 3 to 4 orders, lax or somewhat congested; bracts lanceolate to ovate or trifid, 15–20 mm, white, adaxially glabrous, abaxially glabrous or puberulent; bracteoles lanceolate to ovate, 8–16 mm, white; pedicels absent or to 2.3 mm. Flowers 5-merous, heterodistylous. Long-styled flowers: calyx campanulate, 1–2.5 mm wide, outside puberulent, glabrous inside, truncate or some flowers with 1 to 3 lobes, lobes equal to unequal, 6–15 mm, elliptic to narrowly elliptic or elliptic-oblong, white; corolla

white, clavate in bud, when open salverform or infundibuliform, outside glabrous, tube 9–11.5 mm, 1–2.5 mm diam., inside glabrous, lobes 3.5–4 mm, ligulate or elliptic-oblong, acute; anthers included, filaments inserted in upper third of corolla tube, 0.5–1 mm; style 11–13 mm, glabrous, stigmas 0.7–2 mm. Short-styled flowers: similar to long styled except calyx 0.7–2.5 mm; corolla tube 10–16 mm, 2–4.5 mm diam., lobes 3–4 mm; anthers shortly exerted, 2.5–3 mm; style 9–10 mm, stigmas 3–3.5 mm. Drupes violet-black or blue, globose, 4–8 × 5–7 mm; pyrenes spherical or hemispherical, ± rugose, finely fissured, endosperm entire.

Distribution and habitat. This species grows in Madagascar, where it is known from the provinces of Antananarivo, Antsiranana, Fianarantsoa, Mahajanga, and Toamasina. Here, it grows in humid forests at elevations of 100–1200 m.

Phenology. This species has been collected with flowers in January, February, November, and December, and with fruits January through May and in November and December.

Discussion. The calyx of *Gaertnera phyllostachya* appears at first glance to be regularly lobed, but the top of the limb is actually truncate or denticulate in most flowers; in a minority of the flowers it is truncate with one to three well-developed lobes. The flowers are also regularly subtended by two showy bracts that are fused to the base of the calyx and seem to have been confused with calyx lobes by some authors, but these clearly arise well below the top of the calyx limb. Similarly, though, smaller bracts are borne at the top of the pedicel in several other species of *Gaertnera*, thus these structures are interpreted here as bracts. This species is morphologically quite variable, from slender plants with relatively small leaves and deciduous stipules (e.g., *Miller & Miller 3821* [MO]; *Rasoavimbahoka et al. 69* [MO]) to robust plants with relatively large leaves and larger persistent stipules (e.g., *Schatz & Miller 2432* [MO]; *Nicoll 202* [MO]). The presence, number, and form of the leaf domatia also vary notably, apparently without correlation to these other characters.

This species is largely restricted to eastern forests of Madagascar at 100–1200 m altitude; however, it has also been collected in western forests near Mahajunga, at an elevation not recorded (*D'Alleizette 1477*, P). *Gaertnera phyllostachya* is similar to *G. phyllosepala*; see additional comments under that species.

Three syntypes were cited in the protologue, *R. Baron 2327* (K!), *R. Baron 2683* (K), and *L. Humblot 510* (K!, P!). The first specimen is selected here as

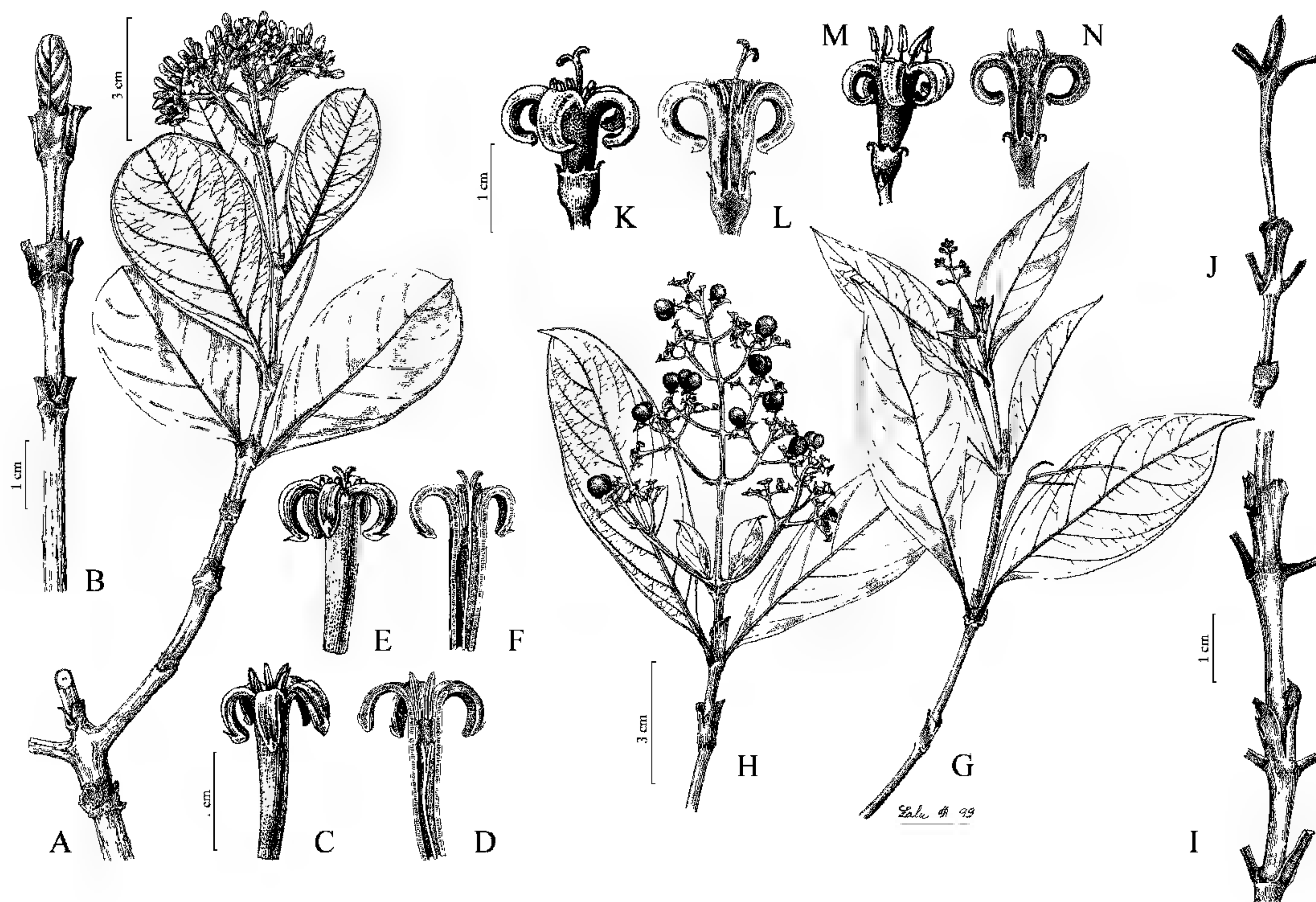

Figure 15. A–F. *Gaertnera psychotrioides* (DC.) Baker. —A. Flowering branch. —B. Portion of stem with stipules and stem apex with young leaves. —C. Short-styled flower. —D. Short-styled flower in cross section. —E. Long-styled flower. —F. Long-styled flower in cross section. G–N. *Gaertnera vaginans* (DC.) Merr. —G. Flowering branch. —H. Fruiting branch. —I. Portion of stem with petiole bases and stipules. —J. Portion of stem with petiole bases, stipules, and stem apex. —K. Long-styled flower. —L. Long-styled flower in cross section. —M. Short-styled flower. —N. Short-styled flower in cross section. C–F to same 1-cm scale; G, H to same 3-cm scale; I, J to same 1-cm scale; K–N to same 1-cm scale. A–F based on *Malcomber 2931*; G, I–N based on *Malcomber 2760*; H based on *Malcomber 2761*.

lectotype because it is a more complete and exemplary specimen.

Representative specimens examined. MADAGASCAR. **Antananarivo:** Ankeramadrinka, *Scott-Elliot 1774* (K). **Antsiranana:** Marojejy Nature Reserve, *Miller 3918* (MO, P), *Randrianasolo 70* (MO, TAN), *Humbert 22106* (P). **Fianarantsoa:** Andringitra Nature Reserve, *Lewis 786* (MO, P); Ranomafana National Park, *Nicoll 202* (MO, P, TAN), *Malcomber 2589* (K, MO, P, TAN), *2866* (MO), *Overdorff 24* (MO), *Schatz & Miller 2432* (MO, P, WAG). **Mahajanga:** near Mahajanga, *D'Alleizette 1477* (P). **Toamasina:** Ambodivoangy, *Cours 1843* (P, TAN); Analamazaotra, *Capuron SF 568* (P, TEF), *C. D'Alleizette s.n.* (P), *Perrier de la Bâthie 4014* (MO, P); Andasibe (Perinet), *Cours 4414* (P), 830 m, *Croat 32246* (MO, TAN, WAG), *Dorr 3080* (MO, P, WAG), *Evrard 11243* (BR), *Lowry 4262* (MO, P, TAN, WAG), *Miller & Miller 3821* (MO, P, TAN); Betampona Nature Reserve, Vohimarangitra, *Cours 2543* (P); Didy, Brickaville, *Cours 4804* (P); Masoala Peninsula, *Malcomber 2733* (MO), *2821* (MO); Moramanga, *Decary 15297* (MO, P), *6907* (P), *7085* (P), *Rabevohitra 2578* (TEF), *6907* (P), *7085* (P); Zahamena Nature Reserve, *Ramanatsoavina RN 2814* (MO, TAN).

56. *Gaertnera psychotrioides* (DC.) Baker, *Fl. Mauritius* 231. 1877. Basionym: *Chassalia psychotrioides* DC., *Prodr.* 4: 531. 1830. *Sykesia*

psychotrioides (DC.) Kuntze, *Revis. Gen. Pl.* 2: 425. 1891. TYPE: Mauritius. s. loc., *F. W. Sieber 57* (holotype, G!; isotypes, E!, K!, MO!, OXF!, P!, W!, WU!). Figure 15A–F.

Chassalia coffeoides DC., *Prodr.* 4, 531. 1830. *Coffea chasaloides* D. Dietr., *Syn. Pl.* 1: 777. 1839, nom. superfl. illeg. TYPE: Mauritius. s. loc., *F. W. Sieber 335* (holotype, G–DC not located).

Gaertnera bifida Bojer, *Hortus Maurit.* 217. 1837. TYPE: Mauritius. Quartier Militaire and Moka, *W. Bojer s.n.* (holotype, P not located; isotype, BM!).

Gaertnera parviflora Bojer, *Hortus Maurit.* 217. 1837. TYPE: Mauritius. Savanne and Trois Ilots, *W. Bojer s.n.* (holotype, P not located).

Gaertnera quadriseta A. DC., *Prodr.* 9: 34. 1845, syn. nov. TYPE: Mauritius. s. loc., *W. Bojer s.n.* (holotype, G–DC microfiche!).

Gaertnera quadriseta var. α *brevipes* A. DC., *Prodr.* 9: 34. 1845, syn. nov. TYPE: Mauritius. s. loc., *F. W. Sieber 272* (holotype, G–DC!; isotypes, BM!, E!).

Gaertnera quadriseta var. β *platypoda* A. DC., *Prodr.* 9: 34. 1845, syn. nov. TYPE: Mauritius. s. loc., *W. Bojer s.n.* (syntypes, G–DC microfiche!).

Gaertnera quadriseta var. γ *hebeopoda* A. DC., *Prodr.* 9: 34. 1845, syn. nov. TYPE: Mauritius. s. loc., *F. W. Sieber 332* (holotype, G–DC!; isotypes, E!, P!).

Gaertnera quadriseta var. *δ petiolaris* A. DC., Prodr. 9: 34. 1845, syn. nov. TYPE: "Ile de France ou Bourbon," s. coll., "ex Paris 1821" (holotype, G-DC!).

Gaertnera truncata A. DC., Prodr. 9: 34. 1845, syn. nov. TYPE: Mauritius. s. loc., *F. W. Sieber 54* (holotype, G-DC!; isotypes, E!, G!, K!, L!, P!, W!).

Trees or shrubs, (0.6–)1.8–12 m tall; *branches* terete, glabrous, 2–8 mm diam.; internodes 1–5.5 cm, smooth. *Leaf* blades 2.5–17.5 × 1.1–8.3 cm, oblanceolate to elliptic-oblong, elliptic-lanceolate, or elliptic, apex rounded or acute to acuminate, base cuneate to acute, drying coriaceous, glabrous; secondary veins visible and flat to prominent abaxially, 5 to 8 pairs; domatia present; petioles 5–35 mm. *Stipules* tubular, glabrous or puberulent to pubescent, drying chartaceous, persistent or sometimes fragmenting, tube 2–12 mm, with ribs 4, narrowly winged, arising beneath petiole, angling to meet in middle of interpetiolar side and sometimes extending to lobes, apex entire or with 2 incisions, marcescent, lobes 4, 1–5 mm, linear. *Inflorescences* cymose, many-flowered, terminal on axillary branches, puberulent or glabrous; peduncle 3.5–6 cm; branched portion corymbiform, 1.5–10 × 3–15 cm, branched to 3 to 4 orders, lax or usually rather congested; bracts deltate to linear or trifid, 3–9 mm; bracteoles triangular to ovate, 1–2 mm; pedicels absent or to 1.5 mm. *Flowers* 5-merous, heterodistylous. *Long-styled flowers*: calyx cup-shaped, 2–4 mm wide, glabrous, truncate or lobes to 0.2 mm, triangular; corolla white, clavate in bud, when open salverform, outside puberulent or glabrous, tube 10–12.5 mm, 2–2.5 mm diam., inside villous in upper third, lobes 4.5–5.5 mm, ligulate to linear, acute; anthers shortly exerted, filaments inserted in upper third of corolla tube, 1–1.5 mm; style 15–17 mm, glabrous (pubescent near apex), stigmas 1–1.5 mm. *Short-styled flowers*: similar to long styled except corolla tube 11–14 mm, 2.5–3 mm diam., lobes 4–5 mm; filaments ca. 2 mm; style 9–10 mm, stigmas ca. 1 mm. *Drupes* violet-black or blue, ellipsoid, 7–10 × 6–8 mm; pyrenes plano-convex, rugose, finely fissured, endosperm entire.

Distribution and habitat. This species grows in Mauritius, where it is found in wet evergreen forests and in the heathlike vegetation on lava flows ("groundwater laterite"), at elevations of 200–812 m.

Phenology. This species has been collected with flowers in January, May, November, and December, and with fruits February through June.

Discussion. *Gaertnera psychotrioides* is frequently encountered within the forests of Mauritius. Unlike the similar species *G. hirtiflora*, *G. psychotrioides* lacks setae at the top of the stipule tube and has

externally glabrous corollas. *Gaertnera psychotrioides* might also be confused with *G. edentata*, but can be distinguished by its lax corymbiform inflorescences 3–15 cm wide and its smaller flowers.

Verdcourt (1989) separated *Gaertnera quadriseta*, noting that it is imperfectly known and distinguishing it by its corolla tube ca. 3 mm in diameter, versus what he characterized only as a narrow corolla tube in *G. psychotrioides*, and also in having relatively larger though overlapping conditions of several characters such as leaves and bracts. According to the species circumscription used here, these are not distinct taxa and are not separated here. Verdcourt (1989) also separated *G. truncata*, noting that this species was imperfectly known and separating it by its "truncate to very lightly lobed" calyx, in contrast to subtruncate or with lobes 0.5–0.8 mm long in *G. psychotrioides* of Verdcourt's description. The characters of *G. truncata* thus fall within the variation found in *G. psychotrioides*, and this species is not separated here.

Representative specimens examined. MAURITIUS. Bel Ombre, *D'Argent MAU 22454* (MAU), *Lorence 2209* (MO), *4449* (MO), *4490* (MO); Mt. Le Pouce, *Bernardi 14714* (BM, G, K, MO, P), *G. Gardner s.n.* (K), *Lorence 1956* (MO), *Tirvengadam 379/29* (MAU); Black River Gorges National Park, *Malcomber 2938* (MO), *2939* (MO), *Bernardi 14778* (G, P); Macabé, *Bernardi 14714* (K), *14794B* (K), *Vaughan MAU 13761* (MAU), *Lorence M 281* (MO), *1495* (MAU, MO), *2125* (MO), *Malcomber 2946* (MO), *2947* (MO), *Tirvengadam 396/46* (MAU); Plaine Champagne, *Lorence 1541* (MAU, MO), *Coode 4765* (K, MAU, P), *Malcomber 2930* (MO), *2931* (MO).

57. *Gaertnera ramosa* Ridl., J. Linn. Soc., Bot. 38: 317. 1908. TYPE: Malaysia. Gunong Tahan, 3 July 1905, *H. G. Robinson & L. Wray, Jr. 5488* (holotype, SING!; isotypes, BM!, K!, SING!).

Gaertnera pedicellata Ridl., J. Straits Branch Roy. Asiat. Soc. 79: 99. 1918. TYPE: Malaysia. Selangor: Gunong Minghuan, 6 Feb. 1913, *H. G. Robinson s.n.* (holotype, K!; isotype, SING!).

Gaertnera sessiliflora Ridl., J. Straits Branch Roy. Asiat. Soc. 79: 99. 1918. TYPE: Malaysia. *H. G. Robinson s.n.* (holotype, K!; isotype, SING!).

Gaertnera caudata Ridl., J. Fed. Malay States Mus. 6: 51. 1915. *Gaertnera acuminata* var. *montana* Ridl., Fl. Malay Penins. 2: 428. 1923. TYPE: Malaysia. Perak: Gunong Kerbau, 14 Mar. 1913, *H. G. Robinson s.n.* (holotype, K!).

Trees or shrubs, 3–5(–8) m tall; *branches* terete to flattened, glabrous, 1–4 mm diam.; internodes 0.6–7.5 cm, smooth. *Leaf* blades 3–14.5 × 0.8–5 cm, elliptic-lanceolate to elliptic, oblanceolate, or linear-lanceolate, apex cuspidate to acuminate, base acute to cuneate, drying chartaceous, glabrous; secondary veins distinct abaxially, 3 to 9 pairs; domatia absent or present, hirtellous and sometimes foveolate; petioles 3–25 mm. *Stipules* tubular, glabrous, drying

membranous, marcescent or caducous, tube 7–15 mm, with ribs 4, narrowly winged, arising below petiole and sometimes extending to lobes, apex usually entire or with 1 incision, marcescent, lobes 4, up to 2.5 mm, deltate to filiform. *Inflorescences* cymose, several-flowered, terminal on axillary branches, glabrous, sessile or peduncle to 4.5 cm; branched portion corymbiform, 1–7.5 × 1–6 cm, branched to 2 to 3 orders, lax (congested in apical part); bracts linear or deltate, 1–5 mm; bracteoles reduced; pedicels absent or to 5 mm. *Flowers* 5-merous, unisexual. *Pistillate flowers*: calyx cup-shaped, 2.5–3.5 mm wide, glabrous, truncate or lobes to 0.8 mm, triangular; corolla white, clavate in bud, when open salverform, outside glabrous or puberulent, tube 5–10 mm, 1.5–4 mm diam., inside villous in upper third, lobes 2–4 mm, ligulate or ovate-oblong, acute; staminodia included, filaments inserted in upper third of corolla tube, ca. 0.5 mm; style 6–10 mm, glabrous, stigmas 2–2.5 mm. *Staminate flowers*: similar to pistillate except anthers shortly exerted, filaments 1–8 mm; pistillodes with style portion 4–6 mm, stigmatic portions 0.8–1.5 mm. *Drapes* violet-black or blue, globose or didymous, 7–8 × 7–11 mm; pyrenes spherical or hemispherical, rugose, finely fissured, endosperm entire.

Distribution and habitat. This species grows in southeastern Asia, where it is known from Peninsular Malaysia at elevations of 450–2100 m and is particularly frequently encountered in the Cameron and Genting highlands. Here, it is found in humid forests at elevations of 1300–1600 m.

Phenology. This species has been collected with flowers January through April and May through December, and with fruits April through October.

Discussion. This species belongs to the *Gaertnera vaginans* complex; see also the discussion of that group for related species and their distinctions. Van Beusekom (1967) considered *G. ramosa* a synonym of *G. vaginans* subsp. *junghuhniana*. Although *G. ramosa* is phenotypically similar to some of the fewer-flowered forms of *G. junghuhniana*, it is recognized here as a separate species based on its larger, often pedicellate flowers. *Gaertnera ramosa* might be confused with *G. belumutensis*, but differs in the lax inflorescence and in not drying with an orange cast.

Representative specimens examined. MALAYSIA. **Pa-hang:** Cameron Highlands, Bukit Jasar, *Wong FRI 32350* (A, K, KEP, L, SAN, SING), *Henderson SING 23390* (BM, FHO, SING); Fraser's Hill, *Purseglove 4227* (A, K, L); Pine Tree Hill, *Nickille 4816* (K).

58. *Gaertnera raphaelii* Malcomber, sp. nov.
TYPE: Madagascar. Fianarantsoa: Ranomafana National Park, 21°13'S, 47°27'E, 900 m, Nov.

1991, *S. T. Malcomber et al. 1018* (holotype, MO-4570509!; isotypes, BR!, G!, TAN!, WAG!). Figure 4G–I.

Haec species *Gaertnerae obovatae* Baker similis, sed ab ea inflorescentiae bracteis albis prominentibus atque in quoque flore lobulis calycinis uno duobusve in calycophylla alba petaloidea expansis distinguitur.

Trees or shrubs, 2–10 m tall; *branches* flattened or terete or quadrangular, glabrous, 2–4 mm diam.; internodes 1.5–4 cm, smooth. *Leaf* blades 3.2–11 (–14) × 1–4 (–5.5) cm, elliptic to oblanceolate or elliptic-oblong, apex shortly cuspidate or acuminate, base cuneate to obtuse, drying chartaceous, glabrous; secondary veins distinct, thinly prominulous, 5 to 8 pairs; domatia usually present; petioles 3–11 (–14) mm. *Stipules* calyptrate, glabrous, drying membranous, caducous or quickly fragmenting, tube 11–30 (–55) mm, with ribs 4, rounded to narrowly winged, arising beneath petiole and sometimes extending to apex, apex with 1 incision, marcescent, lobes 2, 0.5–0.7 mm, deltate or linear. *Inflorescences* cymose, many-flowered, terminal on axillary branches, puberulent to glabrescent; peduncle 0.5–4 cm; branched portion corymbiform, 1.4–7.5 × 1.4–7.5 (–9) cm, branched to 3 to 4 orders, lax or sometimes congested near apex; bracts linear to ligulate or trifid, 5–15 mm, white; bracteoles triangular to ovate, 1–2.5 mm, white; pedicels absent or to 2 mm. *Flowers* 5-merous, heterodistylous. *Long-styled flowers*: calyx cup-shaped or campanulate, 1.7–2.5 mm wide, outside glabrous, with hair-ring inside, lobes unequal with 1 or 2 larger, 1–5 mm, linear to triangular or elliptic-oblong, white; corolla white, clavate with thickened abaxial appendages at apex in bud, when open salverform, outside glabrous, tube 8–10 mm, 2–3 mm diam., inside villous in upper third, lobes 2–3 mm, triangular to ligulate, acute; anthers included, filaments inserted in upper third of corolla tube, 0.3–0.5 mm; style 6–8 mm, glabrous, stigmas 1–4 mm. *Short-styled flowers*: similar to long styled except calyx 1.5–3 mm wide; corolla tube 6.5–10 mm; anthers shortly exerted, 1.5–2 mm; style 4–5 mm, stigmas 2–2.5 mm. *Drapes* violet-black, globose or didymous, 4–8 × 5–8 mm; pyrenes spherical or hemispherical, rugose, finely fissured, endosperm entire.

Distribution and habitat. This species grows in Madagascar, where it is known from the provinces of Fianarantsoa and Toliara, in the Ranomafana, Andringitra, and Andohahela Nature Reserves. Here, it is found in humid forests at elevations of 150–1150 m.

Phenology. This species has been collected with flowers September through December and with fruits January through April and in December.

Discussion. *Gaertnera raphaelii* is similar to *G. obovata*, *G. humblotii*, and *G. phyllostachya*, but can be distinguished by its elliptic unequal calyx lobes and inflorescence bracts, with only one or two enlarged calyx lobes per flower. *Gaertnera humblotii* is similar to *G. raphaelii*, in particular in the distinctive bracts and calyx lobes, but differs in its longer calyx lobes, 5–7 mm long, larger leaves, and tubular stipules. *Gaertnera raphaelii* may hybridize with *G. phanerophlebia*; see additional comments under that species.

Gaertnera raphaelii is named in honor of Malagasy botanist Raphael Rakoto, who made some of the early collections of this species from Ranomafana National Park before his untimely death in 1995.

Paratypes. MADAGASCAR. Manampanihy Valley, *Humbert 6056* (MO, P); Sakaleona Valley, *Decary 14342* (MO, P); *Bernardi 11535* (K); *Nicoll 106* (P, TAN). **Fianarantsoa:** Ambalavao, Mahazory, Vohimary, *Rakotovoao 537* (TEF); Andranomanaraka, Tolongoina, *Unknown Collector SF 5231* (TAN); Andringitra Nature Reserve, *Lewis 819* (MO, P), camp 1, ca. 45 km S of Ambalavao, *Lewis 756* (MO, P), camp 2, Ivongo, Ambahatsy, *Rakotovoao 108* (MO); Anolatsiky-Tolongoina, Fort Carnot, *Unknown Collector SF 7130* (P); Farafangana, Ankazomaneno, *Ratsirahonana F-15372* (TEF, MO); Fort Carnot, Andrianonianaraka, *Unknown Collector SF 5232* (TEF); Iantara, Manampatra Basin, *Humbert 3366* (P); Ivongo, Farafangana, *Rakotovoao RN 6841* (P), *RN 8509* (P); Marovaky, Ivohibe Bara, *Armand 26* (P); Midongy-Sud, *Akondrovao SF 26415* (TEF); Ranomafana National Park, *Malcomber 999* (BR, G, MO, TAN, WAG), Parcel 3, Talatakely, *Turk 421* (MO), *Malcomber 2875* (MO), *2878* (MO), *Schatz & Miller 2425* (K, MO, P, WAG), *Nicoll 105* (MO, TAN); Valley of Ianlara, Ivohibe-Farafangana, *Unknown Collector SF 1458* (P, TAN, TEF), *SF 1472* (P, TAN, TEF). **Toliara:** Andohahela Reserve, *Leeuwenberg 14017* (WAG), *Malcomber 1172* (MO, TAN), *Schatz & Miller 1228* (MO, P, TAN); NW of Eminiminy, Itrotroky River, *Malcomber 2155* (MO, P), parcel 1, Eminiminy, *Randrianampiona 45* (MO, P); Fort Dauphin, Ivondro, *Decary 10814* (P); Tsitongabarika, *Decary 11018* (P).

59. *Gaertnera rosea* Thwaites ex Benth., J. Proc. Linn. Soc., Bot. 1: 111. 1857. *Sykesia rosea* (Thwaites ex Benth.) Kuntze, Revis. Gen. Pl. 2: 425. 1891. TYPE: Sri Lanka. *G. H. K. Thwaites CP 2673* (lectotype, designated by van Beusekom, 1967 [1968]: 377, K!; isotypes, BM!, BO not seen, BR!, CGE!, G!, GH!, L!, P not seen, PDA!, W!, WU!). [SYNTYPE: Sri Lanka. *G. W. Walker s.n.* (K not seen).]

Treelets or trees, 2–5 m tall; *branches* terete, glabrous, 0.5–2(–3) mm diam.; internodes 0.3–4.5 cm, with 2 longitudinal ribs. *Leaf* blades 1–7 × 0.5–3 cm, elliptic-lanceolate, elliptic-oblong, or elliptic, apex cuspidate or acuminate, base cuneate, drying chartaceous, glabrous; secondary veins evident and flat to prominulous abaxially, 3 to 6 pairs;

domatia present, foveolate with hirtellous pubescence inside; petioles 0.5–5 mm. *Stipules* tubular, glabrous to densely pilosulose, drying membranous, persistent, tube 1–5 mm, with ribs 4, narrowly ridged, arising above or beneath petiole and extending onto tube, fusing into 1 rib on each interpetiolar side, these extending to lobes, apex entire, marcescent, lobes 2 and deeply bifid or 4, 1.5–5.5 mm, filiform. *Inflorescences* 3-flowered, congested-fasciculate to subcapitate, terminal on axillary branches, glabrous, 0.2–2.3 × 0.4–2.6 cm, sessile or peduncle to 4 cm; bracts deltate or stipuliform, 1.2–2.5 mm; bracteoles reduced; pedicels absent or to 0.6 mm. *Flowers* 4-merous, heterodistylous. *Long-styled flowers:* calyx cup-shaped, 1.5–4 mm wide, glabrous, truncate or lobes to 0.9 mm, triangular; corolla pink on tube and white on lobes, clavate in bud, when open salverform, outside glabrous, tube 12–20 mm, 1–3 mm diam., inside villous in upper third, lobes 7–10.5 mm, ligulate, acute; anthers included, filaments inserted in upper third of corolla tube, 0.2–0.5 mm; style 13–17 mm, glabrous, stigmas 2–5 mm. *Short-styled flowers:* similar to long styled except corolla tube 16–23 mm, 1.5–4 mm diam., lobes 5–11.5 mm; filaments 1.8–4 mm; style 6.5–9 mm, stigmas 2.5–4.5 mm. *Drupes* violet-black, globose or subglobose, 7–10 × 7–10 mm; pyrenes spherical or hemispherical, rugose, finely fissured, endosperm entire.

Distribution and habitat. This species grows in Sri Lanka, where it can be found in humid forests at elevations of 250–1300 m.

Phenology. This species has been collected with flowers May through August and with fruits June through October.

Discussion. *Gaertnera rosea* can be recognized by its ridged internodes, inflorescences reduced to a 3-flowered, congested cyme, and 4-merous flowers with pink corolla tubes and white corolla lobes. Yellow flowers are reported on several specimens (e.g., *Kostermans 23597*); from field observations, it appears that the flowers open with a pink corolla tube and white lobes and then turn yellow as they age as in some other species of Rubiaceae.

Representative specimens examined. SRI LANKA. Galle, Kanneliya, *Waas 1335* (K, MO, PDA). **Ratnapura Distr.:** Mannikkawatta, *Waas 1768* (E, GH, K, L, MO, PDA).

60. *Gaertnera rotundifolia* Bojer, Hortus Maurit. 216. 1837. *Sykesia rotundifolia* (Bojer) Kuntze, Revis. Gen. Pl. 2: 425. 1891. TYPE: Mauritius. Forests of Grand Port and Savanne and around Grand Bassin, *W. Bojer s.n.* (holotype, P not located; isotype, G-DC!).

Trees or shrubs, 1–6 m tall; *branches* flattened, terete, or quadrangular, glabrous, 3–6 mm diam.; internodes 1.3–4 cm, smooth. *Leaf* blades 1.5–12 × 0.8–5.5 cm, broadly elliptic to obovate or ovate, apex obtuse and shortly acuminate to rounded, base cuneate to subcordate, drying thickly coriaceous, glabrous, margins often thinly revolute; secondary veins flat and visible to prominulous abaxially, 6 to 8 pairs; domatia absent; petioles 7–15 mm. *Stipules* calyptrate, glabrous or puberulent, drying membranous, marcescent, tube 15–20 mm, with ribs 4, narrowly winged, arising beneath petiole but not extending to top, sometimes uniting in basal part of interpetiolar portion, apex with 1 incision, marcescent, lobes 2, 1–2 mm, deltate or linear. *Inflorescences* congested-cymose to subcapitate, many-flowered, terminal on axillary branches, puberulent or glabrous; peduncle 0.5–2 cm; branched portion subglobose or corymbiform, 1.3–4 × 1.5–4 cm, branched to 2 to 3 orders, congested; bracts deltate to linear or trifid, 8–10 mm; bracteoles triangular to lanceolate, 2–4 mm; pedicels absent or to 2 mm. *Flowers* 5-merous, heterodistylous. *Long-styled flowers*: calyx cup-shaped or campanulate, 2.5–4 mm wide, outside glabrous, with hair-ring inside, lobes 1–2 mm, triangular to ovate; corolla white, clavate in bud, when open salverform, outside glabrous, tube 15–25 mm, 2–3.5 mm diam., glabrous inside, lobes 5–7 mm, narrowly triangular or ligulate, acute; anthers included, filaments inserted in upper third of corolla tube, ca. 0.5 mm; style 15–25 mm, glabrous, stigmas 2–3 mm. *Short-styled flowers*: similar to long styled except calyx ± campanulate, 2–3.5 mm wide, outside puberulent or glabrous, lobes 1–1.5 mm, triangular to ovate or oblong; corolla clavate in bud or sometimes with appendages at apex, tube 2–4 mm diam., lobes 5–6 mm, narrowly triangular or ligulate to ovate-oblong; anthers shortly exerted, filaments 2–3 mm; style 9–12 mm, stigmas 3–5 mm. *Drupe*s violet-black, ellipsoid to obovoid, 15–17 × 6–8 mm; pyrenes plano-convex, rugose, finely fissured, endosperm entire.

Distribution and habitat. This species grows in Mauritius, where it is found in the heathlike vegetation on lava flows (“groundwater laterite”) at elevations of 500–700 m.

Phenology. This species has been collected with flowers in February and December and with fruits in January, February, and May through December.

Discussion. *Gaertnera rotundifolia* and *G. cuneifolia* are generally similar and were considered the same species by Baker (1877); see the discussion under *G. cuneifolia*. *Gaertnera rotundifolia* was treated

as an unnamed variety “β [beta]” of *Chassalia clusiifolia* DC. by de Candolle (Prodr. 4: 532. 1830), based on the specimen *J. B. G. Bory [de St. Vincent] s.n.* (G-DC!). This variety has been cited by some authors (e.g., Verdcourt, 1989), but because it was unnamed it is not validly published.

Representative specimens examined. MAURITIUS. Curepipe, *Vaughan MAU 1655* (MAU); Perrier Reserve, *Vaughan MAU 12271* (MAU); Black River Gorges National Park, *Petrin, Lorence 1548* (MAU, MO), *Malcomber 2949* (MO), *2955* (MO), *Richardson 4078* (K), *Tirvengadam 947* (K); Plaine Champagne, *Puff 800823–1/5* (K).

61. *Gaertnera schatzii* Malcomber, sp. nov. TYPE: Madagascar. Toamasina: Masoala National Park, Antalvia, 15°47'S, 50°02'E, Nov. 1989, *G. E. Schatz 2808* (holotype, MO-3769600!; isotypes, K!, P!, TAN!, WAG!). Figure 2.

Haec species *Gaertnerae griseae* Hook. f. ex C. B. Clarke similis, sed ab ea planta in sicco aurantiaca, stipulis brunneis semel fissis 22–68 mm longis atque tubo corollino extus dense tomentosum distinguitur.

Shrubs or trees, 3–9 m tall; plants drying with orange cast; *branches* terete, when young densely tomentulose to tomentose with indumentum drying reddened to orange, sometimes with indumentum drying brown or becoming glabrescent, 3–6 mm diam.; internodes 1.4–8 cm, smooth. *Leaf* blades 14–29 × 5–10 cm, elliptic to oblanceolate, apex cuspidate to acuminate, base cuneate to rounded, drying chartaceous, adaxially glabrous, abaxially densely pilosulose to tomentose with indumentum drying reddened to yellow-orange; secondary veins prominulous abaxially, 9 to 12 pairs; domatia absent; petioles 5–20 mm. *Stipules* tubular, densely tomentulose to tomentose, drying chartaceous, generally persisting on distalmost 2 to 5 nodes, tube 22–68 mm, with ribs 4, narrowly to broadly winged, arising below petiole and usually extending to lobes, apex with 1 incision, marcescent, lobes 4, 4.8–7.5 mm, deltate to linear. *Inflorescences* cymose, many-flowered, terminal on axillary branches, densely tomentose; peduncle (absent) 4.9–7.8 cm; branched portion corymbiform, 5–11 × 6–13 cm, branched to 4 to 5 orders, lax to congested; bracts deltate or linear, 3–14 mm, sometimes glabrous above; bracteoles reduced; pedicels absent or to 4 mm. *Flowers* 5-merous, heterodistylous. *Long-styled flowers*: calyx cup-shaped, 3.5–5.5 mm wide, outside densely tomentose, glabrous inside, truncate or lobes to 0.5 mm, triangular; corolla white, clavate in bud, when open infundibuliform or salverform, outside densely strigose to tomentose, tube 11–13 mm, 2–5 mm diam., inside villous in upper third, lobes 4–5 mm, triangular or ligulate, acute; anthers included, filaments inserted

in upper third of corolla tube, ca. 0.5 mm; style 10–12 mm, glabrous, stigmas 2–2.5 mm. *Short-styled flowers*: calyx 2.5–5.5 mm wide; corolla tube 10–12 mm, 2–5.5 mm diam.; anthers shortly exerted, filaments 2–3.5 mm; style 3.5–5 mm, stigmas 2–4 mm. *Drupes* unknown.

Distribution and habitat. This species grows in Madagascar, where it is known from the province of Toamasina in the Masoala National Park. Here, it is found in humid forests at elevations of 0–380 m.

Phenology. This species has been collected with flowers in October and November, but has not been collected with fruits.

Discussion. A localized species, this is only known from the Antalavia River Valley on the west coast of the Masoala Peninsula. *Gaertnera schatzii* can be recognized by its dense pubescence that becomes orange on dried specimens, once-cleft stipules that dry brown, and densely tomentose corolla tubes. This species is named after George Schatz, who collected the type specimen and has made significant contributions to our knowledge of the flora of Madagascar.

Paratypes. MADAGASCAR. **Toamasina:** Masoala National Park, Antalavia, *Rahajaso* 923 (K, MO, P, TAN), 1089 (MO, TAN), *Malcomber* 2825 (MO, P, TEF), 2829 (MO, P, TEF), [no initial] *Moise* 9 (MO).

62. *Gaertnera schizocalyx* Bremek., Bull. Misc. Inform. Kew 1940: 193. 1940. TYPE: Malaysia. Sarawak: Matang, Nov. 1871, *P. B. Beccari* 1799 (holotype, K!; isotype, K!).

Shrubs or small trees, 2–3 m tall; *branches* terete, when young densely hispid to villous with indumentum drying yellow to white, becoming glabrescent, 2.5–6 mm diam.; internodes 3–11 cm, smooth. *Leaf* blades 6–14 × 2–5 cm, elliptic to oblanceolate or obovate, apex cuspidate or acuminate, base obtuse to cuneate, drying chartaceous, adaxially glabrous or hirtellous on principal veins, abaxially densely hispid to villous or villosulous with indumentum drying yellow or gray-white; secondary veins prominulous abaxially, 3 to 7 pairs; domatia absent; petioles 3–7 mm. *Stipules* tubular, densely villous to hispid, drying chartaceous to membranous, persistent on distalmost nodes or deciduous leaving persistent wings, tube 10–15 mm, with ribs 4, broadly winged, arising below petiole and extending to lobes, apex entire or with 2 incisions, marcescent, lobes 4, 2–12 mm, linear to deltate. *Inflorescences* several- to many-flowered, congested to subcapitate, terminal on axillary branches, densely villous to villosulous or pilosulose, sessile or peduncle to 2.5 cm; branched portion subglobose, 1.2–3 × 1.2–3 cm, branched to 1

to 2 orders; bracts deltate or trifid, 1–10 mm; bracteoles reduced; pedicels absent or to 2 mm. *Flowers* 5-merous, unisexual. *Pistillate flowers*: unknown. *Staminate flowers*: calyx campanulate, 1.5–2 mm wide, outside pilosulose to hispidulous, glabrous inside, lobes 0.5–4 mm, narrowly triangular; corolla white, clavate in bud, when open salverform, outside glabrous, tube 4–5 mm, 1.5–2 mm diam., inside villous in upper third, lobes 1.5–2.5 mm, ligulate or ovate-oblong, acute; anthers shortly exerted, filaments inserted in upper third of corolla tube, ca. 0.2 mm; pistillode reduced or absent. *Drupes* violet-black, globose or didymous, 5–8 × 5–10 mm; pyrenes spherical or hemispherical, ± rugose, finely fissured, endosperm entire.

Distribution and habitat. This species grows in southeastern Asia, where it is known from Peninsular Malaysia and Borneo in the Sarawak (Malaysia) sector. Here, it can be found in humid forests, usually at the edges of swamps and riverbanks, at an elevation of ca. 10 m.

Phenology. This species has been collected with flowers May through July and with fruits in October and November.

Discussion. *Gaertnera schizocalyx* is not well known. In the Panti Forest Reserve, in Johor, Malaysia, it appears to be restricted to swamp forests. The species can be recognized by its subglobose, subcapitate, sessile or very shortly pedunculate inflorescences, dense hispid to villous indumentum, and well-developed, narrowly triangular calyx lobes. It is similar to *G. capitulata*, which differs in its smaller 4-merous flowers.

Additional specimens examined. MALAYSIA. **Johor:** Panti Forest Reserve, 1.7 km W of Rte. 3, *Malcomber* 3026 (MO); Sungai Kayu, *Kiah SFN* 32015 (A, L, SING); Sungai Kayu, Mawai-Jemaluang rd., *Corner SFN* 32507 (L), 7 July 1935, *E. Corner s.n.* (SING).

63. *Gaertnera spicata* K. Schum., Bot. Jahrb. Syst. 33: 372. 13 Mar. 1903. TYPE: Gabon. Estuaire: Munda [Mondah], Sibange Farm, 21 Aug. 1879, *H. Soyaux* 24 ([holotype, B†]; lectotype, designated here, K!; isotype, P!).

Gaertnera rhodantha Baker, in Oliver, Fl. Trop. Afr. 4 (1, pt. 3): 543. 30 Mar. 1903. TYPE: Gabon. Estuaire: Munda [Mondah], Sibange Farm, 21 Aug. 1879, *H. Soyaux* 24 (holotype, K!; isotype, P!).

Trees or shrubs, 1.5–8 m tall; *branches* terete or quadrangular, when young puberulent with indumentum drying reddish to brown, when older puberulent to glabrescent, 3–6 mm diam.; internodes 1.5–10.5 cm, smooth. *Leaf* blades 18–29 × 5–9 cm, oblanceolate to obovate, apex cuspidate to acute, base attenuate or

cuneate, drying chartaceous, adaxially glabrous, abaxially glabrous or puberulent on principal veins; secondary veins indistinct or prominulous abaxially, 8 to 12 pairs; domatia absent; petioles 15–32 mm. *Stipules* tubular, densely pilosulose or strigillose to glabrescent, drying chartaceous, persistent on distal-most nodes, tube 10–17 mm, with ribs 4, broadly winged, arising below petiole and extending to lobes, apex entire or with 1 or 2 incisions, marcescent, lobes 4, 5–15 mm, deltate to linear; setae numerous, 1.5–6 mm. *Inflorescences* many-flowered, terminal on principal and/or axillary branches, densely strigillose to puberulent; peduncle 2–3.5 cm; branched portion spiciform to narrowly pyramidal, 1.7–5.5 × 0.9–1.5 cm, unbranched or branched to 1 to 2 orders, densely congested; bracts deltate or linear to lanceolate, 1–10 mm, sometimes glabrous; bracteoles reduced. *Flowers* sessile or subsessile, 5-merous, heterodistylous. *Long-styled flowers*: calyx cup-shaped, 1.5–4.5 mm wide, glabrous or sometimes puberulent outside, truncate or lobes to 0.5 mm, triangular; corolla red to orange-red on tube and red or internally white on lobes, clavate in bud, when open salverform, outside puberulent or glabrous, tube 9–11 mm, 1.5–2.5 mm diam., inside villous in upper third, lobes 3.5–4.5 mm, ligulate to lanceolate, acute; anthers included, filaments inserted in upper third of corolla tube, ca. 0.3 mm; style 10–14 mm, glabrous, stigmas 0.8–1.5 mm. *Short-styled flowers*: similar to long styled except corolla tube 9–10 mm, 1.5–3 mm diam., lobes 4–6 mm; anthers fully exerted, filaments inserted in upper third of tube, 1.5–2 mm; style 5.5–6 mm, stigmas 1.5–2 mm. *Drupes* reddish brown (*Breteler & de Wilde 389*) or perhaps violet-black, subquadrangular to subglobose, flattened and ± caniculate at apex, 8–11 × 8–12 mm; pyrenes wedge-shaped, rugose, finely fissured.

Distribution and habitat. This species grows in Central Africa, where it is known from Gabon. Here, it is found in coastal forests on white sands, at elevations at sea level or very near it.

Phenology. This species has been collected with flowers August through October and with fruits in January, February, November, and December.

Discussion. *Gaertnera spicata* is a morphologically isolated and geographically restricted species that can be recognized by its narrow, usually cylindrical inflorescences and red to orange flowers. This species is apparently endemic to coastal white sand forests near Cap Esterias, Gabon. Petit (1959b) provided the publication date for *G. rhodantha* Baker, described almost simultaneously with *G. spicata* from a duplicate set of specimens.

Two syntypes were cited in the protologue of *Gaertnera spicata*, *H. Soyaux 24* (B destroyed, K!, P!) and *H. Soyaux 178* (B destroyed, P!). The former is selected here as lectotype because it is a more exemplary specimen and has more duplicates. The specimen deposited in the Berlin museum would logically be selected as the lectotype but was destroyed along with the general Rubiaceae collection there; the specimen at K is chosen here as the lectotype because it is a more complete specimen and the selection of it makes the synonymy of these two names indisputable.

The names *Gaertnera spicata* and *G. rhodantha* were described independently and simultaneously, and apparently neither author knew about the other name so the publication of these two names based on the same plants is a coincidence. Each author based his name on a different duplicate from the set of specimens of *Soyaux 24*, thus each of these names has a different holotype or lectotype. Presumably each author intended to include all the duplicate specimens of that set in his species, as is the custom today for designating isotypes and as done here.

Representative specimens examined. GABON. **Estuaire:** Cap Santa Clara & Cap Esterias, *Reitsma 1336* (WAG); Mondah Forest, 25 km along the rd. from Libreville to Cape Esterias, ca. 1 km from seashore, *Breteler & J. J. F. E. de Wilde 389* (K, MO, P, WAG); Mt. Bouet, *Leroy 8* (P).

64. *Gaertnera sralensis* (Pierre ex Pit.) Kerr, *Kew Bull.* 1940: 180. 1940. Basionym: *Psychotria sralensis* Pierre ex Pit., in Lecomte, *Fl. Indochine* 3(3): 344. 1924. *Uragoga sralensis* Pierre ex Pit., in Lecomte, *Fl. Indochine* 3(3): 344. 1924, nom. nud., pro syn. TYPE: Cambodia. “In montibus Sral, prov. de Samrong-tong,” Apr. 1870, *J. B. L. Pierre 1253* (lectotype, designated by van Beusekom, 1967 [1968]: 386, L!; isotypes, K!, P!).

Shrubs, to 3 m tall; *branches* terete, glabrous, 1.5–4 mm diam.; internodes 1–7 cm, smooth. *Leaf* blades 4–13 × 1–4.5 cm, elliptic-lanceolate to elliptic or oblanceolate, apex acuminate to cuspidate, base ± attenuate to cuneate, drying chartaceous, glabrous to variously pubescent, drying green or grayish green or infrequently brown, gray, chestnut, reddish brown, or with a distinctive orange cast; secondary veins distinct abaxially, 4 to 7 pairs; domatia absent; petioles 4–15 mm. *Stipules* tubular, glabrous, drying chartaceous, caducous or deciduous through fragmentation, tube ca. 16 mm, with ribs 4, narrowly winged, arising below petiole and extending to lobes, apex with 1 or 2 incisions, marcescent, lobes 4, ca. 1.6 mm, filiform. *Inflorescences* congested-cymose, several- to sometimes many-flowered, terminal on principal and/or

axillary branches, glabrous, sessile or peduncle to 0.3 cm; branched portion subglobose, 0.5–1.5 × 0.5–2 cm, branched to 1 to 2 orders; bracts deltate to linear or trifid, 1–2 mm; bracteoles reduced; pedicels absent or to 1.5 mm. *Flowers* 5-merous, unisexual. *Pistillate flowers*: unknown. *Staminate flowers*: calyx cup-shaped, 3–3.5 mm wide, outside glabrous, with hair-ring inside, truncate or lobes to 0.4 mm, triangular; corolla in bud white, outside glabrous, up to 3.5–4 mm, 1.5–2 mm diam., inside villous in upper third, lobes 2.5–3 mm, triangular to ligulate, acute; filaments inserted in upper third of corolla tube, ca. 0.5 mm; stamens not seen; pistillode reduced. *Drupes* violet-black, globose, 6–8 × 6–8 mm; pyrenes hemispherical or spherical, ± rugose, finely fissured, endosperm entire.

Distribution and habitat. This species grows in southeastern Asia, where it has been found in Cambodia, Peninsular Malaysia, Thailand, and Vietnam. Here, it grows in humid forests at elevations of 600–1800 m.

Phenology. This species has been collected with flowers January through July and with fruits January through April and October through December.

Discussion. Van Beusekom (1967) considered *Gaertnera sralensis* a synonym of his widely circumscribed *G. vaginans* subsp. *junghuhniana*. With the narrower circumscription of *G. junghuhniana* adopted here, *G. sralensis* is recognized as a separate species distinguished by its subglobose inflorescences, glabrous vegetative structures, and calyx with a hair-ring inside. This species belongs to the *G. vaginans* complex; see also the discussion of that group for related species and their distinctions.

In the protologue, several syntype specimens were cited but without number. These can now be detailed: *J. B. L. Pierre 1253* (the lectotype) (L!), *J. B. L. Pierre 3247* (P!), *E. Poilane 237* (BM!, P!), *274* (P!), [no initial; Vegter, 1988] *Talmy s.n.* (P!), and *C. Thorel 1165* (P!). Two names were published simultaneously for this species by Pitard in the protologue of *Psychotria sralensis*, *P. sralensis* which included *Uragoga sralensis*, which was listed there as a synonym and thus not validly published. The name *P. sralensis* was specifically cited as the basionym for *Gaertnera sralensis*, thus Kerr regarded it as the validly published name. Later, without explanation, van Beusekom (1968: 386) subsequently cited *U. sralensis* as the validly published name and *P. sralensis* as an invalid synonymous name. However, van Beusekom's usage is contrary to the presentation of these names in the protologue, where *P. sralensis* was clearly intended by Pitard to be the accepted

name for this species: he included this species in the treatment of the genus *Psychotria*; the name *P. sralensis* is placed at the beginning of this treatment in boldface type similar to all the other accepted names there, while the name *U. sralensis* is placed second and in italic type similar to other synonyms there; and this species is called *P. sralensis* in the key there.

Representative specimens examined. CAMBODIA. Mont de l'Éléphant, *Poilane 237* (BM, P). MALAYSIA. **Pahang:** Gunong Benom, 29 July 1925, *Federation of Malay States Museum Collector s.n.* (BM, K). THAILAND. **Central:** Kao Kuap, *Kerr 17764* (BM, K, L), *17798* (BM, K), *Put 2864* (BM, K, L), *2939* (BM, K, L). **South:** Khao Luang, *Van Beusekom 839* (K, L). VIETNAM. **Prov. Baria [Ba Ria]:** Mt. Dinh, *Pierre 3247* (P); Ti-tinh, *Thorel 1165* (P).

65. *Gaertnera ternifolia* Thwaites, Enum. Pl. Zeyl. 202. 1864. *Sykesia ternifolia* (Thwaites) Kuntze, Revis. Gen. Pl. 2: 426. 1891. TYPE: Sri Lanka. Near Adam's Peak, *G. H. K. Thwaites CP 440* (lectotype, designated by van Beusekom, 1967 [1968]: 381, P!; isotypes, BM!, BR!, CGE!, G!, GH!, K!, P!, W!, WU!). [SYNTYPE: *G. H. K. Thwaites CP 457* (K!).] Figure 14G–M.

Gaertnera walkeri var. *angustifolia* Benth., J. Proc. Linn. Soc., Bot. 1: 111. 1857. TYPE: Sri Lanka. s. loc., *G. H. K. Thwaites CP 440* (lectotype, designated by van Beusekom, 1967 [1968]: 381, P!; isotypes, BM!, BR!, CGE!, G!, GH!, K!, P!, W!, WU!).

Trees or shrubs, 1–5 m tall; *branches* terete, when young puberulent or glabrous with indumentum drying yellow or gray-white, becoming glabrescent, 1–5 mm diam.; internodes 0.1–1.2 mm, smooth or with 3 longitudinal ribs. *Leaf* blades 0.5–2.5 × 0.1–0.3 cm, narrowly oblong or linear-lanceolate, apex acuminate to acute, base acute to cuneate, drying coriaceous, glabrous to pustulose-scaberulose, margin flat to revolute; secondary veins not visible; domatia absent; petioles 0.2–0.7 mm. *Stipules* shortly tubular to subinterpetiolar, glabrous to densely puberulent, drying chartaceous or membranous, persistent, tube 0.1–0.3(–1) mm, with ribs 6, arising below petioles then uniting in the middle of each interpetiolar side and extending to lobes, apex with 3 incisions, marcescent, lobes 3, 0.1–3 mm, deltate. *Inflorescences* reduced to 1 flower or 2 to 3 fasciculate flowers, terminal, pendulous; peduncles (1–)2–7 mm, puberulent; bracts deltate to linear, 1.5–3 mm, glabrous or puberulent; bracteoles linear, ca. 1 mm, ciliolate. *Flowers* 5(6)-merous, heterodistylous. *Long-styled flowers*: calyx cup-shaped, 2–3.1 mm, outside glabrous to puberulent, glabrous inside, lobes 1.2–2 mm, triangular to linear; corolla white, clavate in bud, when open campanulate, outside glabrous, tube 8–11 mm, 1.5–6.5 mm diam., inside villous at ca.

middle, lobes 2–5 mm, triangular to ligulate, acute; anthers included, filaments inserted at ca. middle of corolla tube, 0.4–0.6 mm; style 7–12.5 mm, glabrous, stigmas 1–1.5 mm. *Short-styled flowers*: similar to long styled except corolla tube 8–12 mm, 1.4–6 mm diam., lobes 3–4 mm; anthers shortly exerted, filaments 3–4 mm; style 3.5–6.5 mm. *Drupes* violet-black, globose or subglobose or didymous, 6–8 × 6–8 mm; pyrenes spherical or hemispherical, rugose, finely fissured, endosperm entire.

Distribution and habitat. This species grows in Sri Lanka, where it lives in wet premontane and montane forests at elevations of 1350–2000 m.

Phenology. This species has been collected with flowers June through October and with fruits January through June and in November and December.

Discussion. *Gaertnera ternifolia* is an attractive and morphologically isolated species distinguished by its relatively small ternate leaves, short persistent stipules, few-flowered inflorescences, and campanulate flowers. There has been some confusion of *G. ternifolia* with *G. ×gardneri*, presumed here to be a natural hybrid between *G. ternifolia* and *G. walkeri*. *Gaertnera ×gardneri* differs from *G. ternifolia* in its mixed opposite and ternate leaves and salverform corolla.

Van Beusekom (1967) cited the *Thwaites CP 440* collection deposited at P as the “holotype” of this species, without explanation. In general, Thwaites’ first set and his (de facto) holotypes are assumed to be deposited at K (Staffleu & Cowan, 1986), and van Beusekom does cite an isotype of *Gaertnera ternifolia* at K so the basis for his selection of the P specimen is unclear; no one else seems to have previously specified any individual collection as the type of that species. In his next nomenclatural paragraph here, for *G. ternifolia* var. *angustifolia* he cites the type as “Lectotype: same as that of *G. ternifolia*.” Thus, these are both considered lectotypifications here, following what at least appears to be van Beusekom’s intent. The reason for his selection of the same lectotype specimen for both names is also not explained; these selections, if accepted by others, do definitively reduce these names to synonymy.

Representative specimens examined. SRI LANKA. **Kandy [Sabaragamuwa Province]**: Adam’s Peak, Moray Estate, *Kostermans 24210* (G, K, L), *24213* (G, K, L), *Sohmer 9884* (GH, K, PDA), *Burt 88* (K, MO, PDA), *Kostermans 27020* (G, K, L); Ratnapura, Pinnawala, *Balakrishnan 548* (K, PDA). **Central Province**: Nuwara Eliya, Peak Wilderness National Park, *Malcomber 2766* (MO, PDA), *2767* (MO, PDA), *Waas 1693* (E, GH, K, L, MO, PDA).

66. *Gaertnera trachystyla* (Hiern) E. M. A. Petit, *Bull. Jard. Bot. État Bruxelles* 29: 382. 1959.

Basionym: *Psychotria trachystyla* Hiern, *Fl. Trop. Afr.* 3: 213. 1877. TYPE: W tropical Africa, Mt. John River, 1°N, 1862, *G. Mann 1791* (holotype, K!).

Gaertnera dinklagei K. Schum., *Bot. Jahrb. Syst.* 28: 88. 1899, syn. nov. TYPE: Cameroon. Bipinde, 1898, *G. Zenker 1763* (lectotype, designated here, MO!; isotypes, BR!, E!, G!, K!, L!, P!, W!, WAG!, WU!).

Gaertnera salicifolia C. H. Wright ex Baker, *Fl. Trop. Afr.* 4: 543. 1903. TYPE: Gabon. Estuaire: Mfôa, *G. Bates 516* (holotype, K!; isotypes, BM!, BR!, G!, P!).

Trees or shrubs, 1.5–3.5 m tall; *branches* terete or flattened at apex, terete below, glabrous to puberulent, 1–4 mm diam.; internodes 0.6–9 cm, smooth. *Leaf* blades 5.4–23 × 1.8–7.6 cm, elliptic to obovate or ovate, apex cuspidate to acute, base acute to cuneate or obtuse, drying chartaceous, adaxially glabrous, abaxially glabrous or puberulent to pilosulose on principal veins; secondary veins prominulous abaxially, 4 to 10 pairs; domatia absent or present; petioles 2–15 mm. *Stipules* tubular, glabrous to densely puberulent or pilosulose, drying chartaceous, caducous or with persistent base 1–2 mm, tube 4–25 mm, with ribs 4, narrowly winged, arising above to below petiole and occasionally extending to lobes, apex entire or with 1 or 2 incisions, marcescent, lobes 4, 0.3–5 mm, deltate to linear. *Inflorescence* cymose to paniculiform, many-flowered, terminal on principal and/or axillary branches, densely puberulent to pilosulose, deflexed to pendulous; peduncle 1.2–8.5 cm long; branched portion narrowly pyramidal or corymbiform, 2–23.5 × 3–19 cm, branched to 1 to 4 orders, lax; axes usually divergent at ca. 90 degrees; bracts deltate or trifid, 1–4 mm, glabrous or pubescent; bracteoles reduced; pedicels 1–9 mm. *Flowers* 4- or 5-merous, heterodistylous. *Long-styled flowers*: calyx cup-shaped, 1.5–2.5 mm wide, outside glabrous to densely puberulent, with hair-ring inside, truncate or lobes to 0.4 mm, triangular; corolla white, clavate in bud, when open salverform, outside glabrous, tube 2.4–3.5 mm, 1–1.7 mm diam., inside villous in upper third, lobes 2.5–3.5 mm, ligulate to elliptic-oblong, acute; anthers included, filaments inserted in upper third of corolla tube, ca. 0.3 mm; style 5–6 mm, glabrous or pubescent near apex, stigmas 0.5–1.1 mm. *Short-styled flowers*: similar to long styled except corolla tube 3–4.5 mm, 1–2 mm diam., lobes 3–4 mm, ligulate to ovate-oblong; anthers fully exerted, filaments 2.5–4 mm; style 2–2.5 mm, glabrous, stigmas 1–1.5 mm. *Drupes* violet-black, globose or subglobose, 6–9 × 6–9 mm; pyrenes spherical or hemispherical, faintly rugose, deeply fissured, endosperm entire.

Distribution and habitat. This species grows in Central Africa, where it is known from Cameroon,

Equatorial Guinea, and Gabon. Here, it is found in wet forests at elevations of 100–300 m.

Phenology. This species has been collected with flowers January through May and September through December, and with fruits in January, February, November, and December.

Discussion. *Gaertnera trachystyla* is variable in leaf shape but can be recognized by its deflexed to pendulous, many-flowered, pyramidal cymes with the axes usually spreading at ca. 90 degrees, and its usually well-developed pedicels. Schumann described *G. dinklagei* as having 4-merous flowers, but close inspection of the type and paratype specimens studied by him reveals that both 4- and 5-merous flowers are borne in the same inflorescence. No morphological characters separate *G. trachystyla* from plants described as *G. dinklagei* and *G. salicifolia* C. H. Wright ex Baker and these are considered synonyms here.

The type collection of *Gaertnera dinklagei* has numerous duplicates that are all equally complete and exemplary specimens, as with most collections by Zenker. The holotype specimen was not explicitly designated in the protologue but would have been the one at B; however, it also would have been destroyed there along with the general Rubiaceae collection so it is presumably lost and a lectotype is needed. The MO specimen is selected as the lectotype here for its good condition and for convenience.

Representative specimens examined. CAMEROON. 2–8 km S of Kribi, *Bos* 3166 (K, MO, P, WAG), *Bos* 3982 (MO, P, WAG), *Bos* 4429 (P, WAG); Bipinde, *Zenker* 2393 (BM, BR, E, G, K, L, P, W, WAG, WU), 4760 (BM, BR, G, K, L, MO, P, W). EQUATORIAL GUINEA. Miton, *Sonké & Esono* 3106 (MO). GABON. **Estuaire:** Mondah Forest, 25 km Libreville–Cap Esterias rd., *Breteler & J. J. F. E. de Wilde* 382 (K, MO, P, WAG); Monts de Cristal, Kinguéle rapids, Mbei River, *N. Hallé* 4437 (P), *W. Hallé & Villiers* 4664 (MO, P). **Ngounié:** 2–15 km SE of forestry Camp Waka, *A. M. Louis* 1344 (WAG), 1309 (K, WAG).

67. *Gaertnera vaginans* (DC.) Merr., Enum. Born. Pl. 580. 1921. Basionym: *Psychotria vaginans* DC., Prodr. 4: 520. 1830. *Ophioxylon arboreum* J. Koenig ex DC., Prodr. 4: 520. 1830, nom. nud., pro syn. *Sykesia koenigii* Arn., Nova Acta Phys.-Med. Acad. Caes. Leop.-Carol. Nat. Cur. 353. 1836, nom. superfl. illeg. *Gaertnera koenigii* (Arn.) Wight, Icon. Pl. Ind. Orient. 4: 6, t. 1318. 1848, as “*konegii*,” nom. superfl. illeg. *Sykesia vaginans* (DC.) Kuntze, Revis. Gen. Pl. 2: 426. 1891. TYPE: Sri Lanka. s. loc., in herb. Van Royen 108, *J. G. Koenig s.n.* (holotype, L!; isotype, L!). Figure 15G–N.

Sykesia thyrsiflora Arn., Nova Acta Phys.-Med. Acad. Caes. Leop.-Carol. Nat. Cur. 18: 353. 1836. *Gaertnera thyrsiflora* (Arn.) Blume, Mus. Bot. 1: 174. 1850. *Gaertnera koenigii* var. *thyrsiflora* (Arn.) Thwaites, Enum. Pl. Zeyl. 202: 1860, nom. illeg. TYPE: Sri Lanka. s. loc., *G. W. Walker* 58 (lectotype, designated by van Beusekom, 1967 [1968]: 385, E!; isotype, E!).

Trees or shrubs, 1–6 m tall; branches terete to flattened, glabrous, 1–10 mm diam.; internodes 1–5.5(–10.5) cm, smooth. Leaf blades 3–20 × 1.5–9 cm, narrowly elliptic to obovate, broadly elliptic, or elliptic-oblong, apex acute to acuminate or rounded, base cuneate to acute, drying chartaceous, glabrous; secondary veins prominent abaxially, 4 to 9 pairs; domatia absent or present; petioles 0.5–32 mm. Stipules tubular, glabrous, drying chartaceous, deciduous through fragmentation, tube 7–22(–27) mm, with ribs none or 4, narrowly winged, arising below petiole and sometimes extending to lobes, apex with 1 or 2 incisions, marcescent, lobes 2 or 4, 0.5–2.5 mm, deltate. Inflorescences cymose, many-flowered, terminal on principal and/or axillary branches, puberulent or glabrous, sessile or peduncle 2–7.5 cm; branched portion corymbiform or pyramidal, (2.5–)10–24 × (1.1–)7–17 cm, branched to 2 to 5 orders, sometimes congested near apex; bracts deltate or linear, 1.5–10 mm; bracteoles reduced; pedicels absent or to 5 mm. Flowers 5-merous, heterodistylous. Long-styled flowers: calyx cup-shaped, 2.5–4 mm wide, outside glabrous or puberulent, glabrous or with hair-ring inside, lobes 0.4–0.9 mm, triangular; corolla white, clavate in bud, when open infundibuliform or salverform, outside glabrous to puberulent, tube 4–5.5 mm, 1.5–3.5 mm diam., inside villous in upper third, lobes 3–7 mm, ligulate to elliptic-oblong, acute; anthers included, filaments inserted in upper third of corolla tube, ca. 0.5 mm; style 6–10 mm, glabrous (pubescent near apex), stigmas 0.7–1.5 mm. Short-styled flowers: similar to long styled except calyx lobes 0.4–1 mm; corolla tube 4–6 mm, 1–3.5 mm diam., lobes ligulate; anthers shortly exerted, filaments 2–4 mm; style 2.5–4.5 mm, stigmas 1–2.5 mm. Drupes violet-black, subglobose or didymous, 4–8 × 4–9 mm; pyrenes spherical or hemispherical, faintly rugose, deeply fissured, endosperm entire.

Distribution and habitat. This species grows in Sri Lanka, where it can be found in wet and premontane forests at elevations of 50–900 m.

Phenology. This species has been collected with flowers January through May and August through December, and with fruits January through April and August through December.

Discussion. *Gaertnera vaginans* is a morphologically variable species, but can be recognized by its

chartaceous tubular stipules that closely surround the stem, its corymbiform to pyramidal, erect, cymose inflorescences, and its bisexual flowers with corolla tubes glabrous to puberulent outside. This and a number of closely related species form the *G. vaginans* complex; see also the discussion of that group for related species and their distinctions and see the discussion of *G. junghuhniana* for further discussion of *G. vaginans*.

Representative specimens examined. SRI LANKA. **Galle Distr.:** Hiniduma Pattuwa, Tawalama, *Hoogland 11406* (A, BR, E, K, L, PDA). **Kalutara Distr.:** Pahingala, *Sohmer 10231* (GH, K, MO, P, PDA, W). **Kandy Distr.:** Laxapana-Maskeliya, Doublecutting, *Kostermans 24101* (A, BM, G, K, L). **Ratnapura Distr.:** Carney, *Sohmer 8797* (BM, GH, MO); Kudawe, Weddagala, *Hoogland 11451* (BM, G, L, PDA).

68. *Gaertnera vaginata* Lam., *Tabl. Encycl.* 2: 273. 1797. *Sykesia vaginata* (Lam.) Kuntze, *Revis. Gen. Pl.* 2: 426. 1891. TYPE: "Île de France" [but surely mislabeled, Verdcourt, 1983], *Commerson s.n.* (holotype, FI not seen; isotypes, G!, P!, P-LA!).

Andersonia vaginata Willd. ex Roem. & Schult., *Syst. Veg.* 5: 21. 1819. TYPE: Madagascar. s. loc., *A. du Petit-Thouars s.n.* (holotype, B-WILLD not seen).

Gaertnera laxiflora Cordem., *Fl. Réunion* (E. J. de Cordemoy) 470. 1895. TYPE: La Réunion. Plaine des Caffres, Grand Tampon, *E. J. de Cordemoy s.n.* (holotype, MARS!).

Gaertnera godefroyana Cordem., *Fl. Réunion* (E. J. de Cordemoy) 469. 1895. TYPE: La Réunion. Petite Plaine des Palmistes, pres de la Grande Monteé, Propriété Godefroy, *E. J. de Cordemoy s.n.* (holotype, P not located; isotype, MARS!).

Trees or shrubs, 1–7 m tall; *branches* terete, glabrous, 2–5.5 mm diam.; internodes 1.5–4 cm, smooth. *Leaf* blades 2.5–15.5 × 1–5 cm, oblanceolate to obovate, elliptic-oblong, or elliptic, apex acuminate, base acute, drying chartaceous, adaxially glabrous, abaxially glabrous and often glaucous; secondary veins prominulous abaxially, 7 to 10 pairs; domatia present; petioles 5–23 mm. *Stipules* tubular, glabrous, drying chartaceous, deciduous or usually persistent at least on distalmost 2 to 4 nodes, tube 4–6 mm, with ribs 4, rounded to narrowly winged, arising beneath petiole and sometimes extending to lobes, apex entire, marcescent, lobes 4, 1–7 mm, linear or filiform, setae 4 to 8, 1–5 mm. *Inflorescences* cymose, many-flowered, terminal on principal and/or axillary branches, glabrous to densely puberulent; peduncle 1.5–6 cm; branched portion corymbiform, 1.5–5 × 2–5 cm, branched to 2 to 3 orders, congested; bracts deltate or fused and trifid, 2–10 mm; bracteoles ovate to elliptic or triangular, 2–4 mm; pedicels absent or to 3.5 mm. *Flowers* 5-

merous, heterodistylous. *Long-styled flowers:* calyx campanulate, 2–4 mm wide, outside glabrous or puberulent, with hair-ring inside, lobes 1–2 mm, ovate to oblong or triangular; corolla white, clavate in bud, when open salverform, outside glabrous (puberulent), tube 16–25 mm, 4–9 mm diam., inside glabrous, lobes 7–11 mm, triangular to ligulate or elliptic-oblong, acute; anthers included (shortly exerted), filaments inserted at ca. middle of corolla tube, 0.5–1.5 mm; style 15–21 mm, glabrous, stigmas 1–2.5 mm. *Short-styled flowers:* similar to long styled except corolla tube 18–20 mm, 4–6 mm diam.; anthers shortly exerted, filaments inserted in upper third of corolla tube, 4–5 mm; style 9–10 mm, stigmas 3.5–4 mm. *Drupe*s violet-black, ellipsoid to subglobose, 10–18 × 7–15 mm; pyrenes (1)2 per drupe, plano-convex, faintly rugose, deeply fissured, endosperm entire.

Distribution and habitat. This species grows in the Mascarene Islands, where it is known from the island of Réunion. Here, it can be found in wet lowland forests, humid middle-elevation forests, and cloud forests at elevations of 100–1800 m.

Phenology. This species has been collected with flowers January through May and August through December, and with fruits January through July and September through December.

Discussion. *Gaertnera vaginata* is widespread and frequently collected on Réunion and can be recognized by its acuminate leaves, stipules with numerous well-developed setae, relatively large white flowers, and ellipsoid or subglobose drupes. The type specimen was attributed to Mauritius, but Verdcourt (1983) noted that this specimen is undoubtedly mislabeled and comes instead from La Réunion. The fleshy, relatively large, white flowers are said to be fragrant (e.g., *Lorence 1425* [MO]); these were collected in the middle of the day (D. H. Lorence, pers. comm.). The authorship and place of publication of the name *G. vaginata* have been variously and usually incorrectly attributed. The name *Mussaenda borbonica* Lapeyrère (Rev. Agric. Île Maurice 2: 85. 1889, as to type based on a plant collected at Petit Brule de Saint Denis, La Réunion) has been cited as a synonym of *G. vaginata* (Verdcourt, 1983), but because of the lack of a physical type, may not be included in formal synonymy here.

Representative specimens examined. FRANCE, RÉUNION. Mare Longue, *Barclay 630* (K, MAU), *Bernardi 14503* (G, K, P), *Cadet 1179* (K), *Tirvengadum 11* (MAU, P); Plaine des Chicots, *Billiet 832* (BR, K), *Capuron SF 28160* (MAU, P); Plaine des Palmistes, *Cadet 592* (K), *Friedmann 2247* (G, MO, P), *Kramer 9220* (MO); Saint Philippe,

Bernardi 15035 (BM, K, P), *Boyer* 59 (P), *Schlieben* 10921 (BR, MAU, MO).

69. *Gaertnera viminea* Hook. f. ex C. B. Clarke, in Hook. f., *Fl. Brit. India* 4: 91. 1883. *Psychotria viminea* Wall., *Numer. List [Wallich] Cat. n.* 8354. 1847, nom. nud. *Sykesia viminea* (Hook. f. ex C. B. Clarke) Kuntze, *Revis. Gen. Pl.* 2: 425. 1891. TYPE: Singapore. *N. Wallich* 8354 (holotype, K!; isotypes, BM!, CGE!, K!).

Trees or shrubs, 3–6 m tall; *branches* terete to flattened, puberulent or glabrous with indumentum drying brown, 1–2 mm diam.; internodes 2–5 cm, smooth. *Leaf* blades (3–)4–10 × (0.75–)1–4 cm, linear-lanceolate to lanceolate or oblong, apex cuspidate or acuminate, base acute to cuneate, drying chartaceous, glabrous; secondary veins prominulous abaxially, 4 to 7 pairs; domatia absent; petioles 2–10 mm. *Stipules* tubular, glabrous, drying chartaceous, persistent or caducous, tube 4–10 mm, with ribs 4, narrowly winged, arising below petiole and sometimes extending to lobes, apex entire, marcescent, lobes (2 or)4, 0.5–1.5 mm, filiform. *Inflorescences* cymose, many-flowered, terminal on principal and/or axillary branches, puberulent to glabrous, sessile or peduncle 1.2–2 cm; branched portion corymbiform, 0.8–7 × 2.5–6 cm, branched to 2 to 4 orders, congested at least near apex; bracts deltate or linear to ligulate, 0.2–3 mm; bracteoles reduced; pedicels absent or to 2 mm. *Flowers* 4-merous, unisexual. *Pistillate flowers*: calyx cup-shaped, 1–2 mm wide, outside glabrous or puberulent, with hair-ring inside, lobes to 0.5 mm, triangular; corolla white, clavate in bud, when open salverform, outside glabrous, tube 3.5–6 mm, 0.75–1.5 mm diam., inside villous in upper third, lobes 0.5–1.5 mm, ligulate or ovate-oblong, acute or obtuse; staminodia included, filaments inserted in upper third of corolla tube, ca. 0.3 mm; style 3–4 mm, glabrous (pubescent near apex), stigmas ca. 1 mm long. *Staminate flowers*: similar to pistillate except corolla tube 3.5–4 mm, 0.8–1.2 mm diam., lobes ca. 1.5 mm, ligulate; anthers shortly exerted, filaments 0.3–0.4 mm; pistillode reduced or absent. *Drupes* violet-black, globose, 5–6 × 5–6 mm; pyrenes spherical or hemispherical, rugose, finely fissured, endosperm entire.

Distribution and habitat. This species grows in southeastern Asia, where it is known from Peninsular Malaysia and Singapore. Here, it is found in humid forests at elevations of 60–1290 m.

Phenology. This species has been collected with flowers January through June and in November and December and has been collected with fruits, but the collection dates have not been recorded.

Discussion. *Gaertnera viminea* is very similar to some plants of *G. junghuhniana*, but can be distinguished by its relatively slender branches, few-flowered cymes, and 4-merous flowers. Van Beusekom (1967) noted that a report of this species from Borneo by Merrill (1921) is apparently erroneous and based on misidentification, probably of a plant treated here as *G. junghuhniana*.

Representative specimens examined. MALAYSIA. **Johor:** Gunong Panti, *Corner* SING 29968 (KEP); Gunong Pulai, *Md. Nur* 7765 (K). **Selangor:** Gunong Lawit, Ulu Trengganu, *Ng FRI* 22075 (K, KEP). SINGAPORE. Bukit Timah, *Ridley* 4828b (BM, K, SING), 8923 (SING), *Sinclair* 5325 (E); National Botanic Gardens, Garden Jungle, *Malcomber* 3010 (MO), *Ridley* 13 (SING).

70. *Gaertnera walkeri* (Arn.) Blume, *Ill. Ind. Bot.* 2, t. 156b. 1850. Basionym: *Sykesia walkeri* Arn., *Pug. Pl. Ind. Or.* 354. 1836. TYPE: Sri Lanka. s. loc., *G. W. Walker* 102 (lectotype, designated by van Beusekom, 1967 [1968]: 380, E!). Figure 12E–J.

Trees, 1–4 m tall; *branches* terete, glabrous, 0.7–3.5 mm diam.; internodes 1.5–7 cm, smooth. *Leaf* blades (1.5–)2.8–7.2(–9.4) × 0.4–2.9(–4) cm, lanceolate or elliptic, apex cuspidate or acuminate, base cuneate to acute, drying chartaceous, glabrous; secondary veins prominulous abaxially, 2 to 6 pairs; domatia present; petioles 2–12 mm. *Stipules* tubular, glabrous, drying chartaceous or membranous, caducous or deciduous through fragmentation, tube 3–10 mm, smooth, apex entire, marcescent, truncate or with lobes 2 to 4, 0.1–0.5 mm, deltate. *Inflorescences* cymose, few- to several-flowered, terminal on principal and/or axillary branches, glabrous or puberulent; peduncle 0.9–1.4(–2) cm; branched portion corymbiform, 1.5–5 × 1.5–4.5 cm, branched to 1(2) orders, lax; bracts deltate or linear, 2–4.5 mm; bracteoles reduced; pedicels absent or 0.8–11(–22) mm. *Flowers* 5-merous, heterodistylous. *Long-styled flowers*: calyx cup-shaped, 2.5–3.5 mm wide, outside glabrous or puberulent, glabrous inside, lobes 0.3–0.5 mm, triangular; corolla white, clavate in bud, when open salverform, outside glabrous, tube 10–12 mm, 2–5 mm diam., inside villous at ca. middle, lobes 5–7.5 mm, ligulate to elliptic-oblong, acute; anthers included, filaments inserted at ca. middle of corolla tube, 0.3–0.8 mm; style 10–12 mm, glabrous to scabrous, stigmas 0.4–2.5 mm. *Short-styled flowers*: similar to long styled except corolla tube 8.5–12 mm, 1.9–5 mm diam., lobes 5–6.5 mm; anthers shortly exerted, filaments 1–2.5 mm; style 4–5 mm, glabrous, stigmas 1.5–2.5 mm. *Drupes* violet-black, globose to subglobose, 8–9 × 8–9 mm; pyrenes spherical or hemispherical, rugose, finely fissured, endosperm entire.

Distribution and habitat. This species grows in Sri Lanka, where it is found in premontane and montane forests at elevations of 750–1650 m.

Phenology. This species has been collected with flowers February through September and with fruits April through November.

Discussion. *Gaertnera walkeri* is generally similar to *G. ramosa* of western Malaysia and to *G. rosea*, also of Sri Lanka; *G. ramosa* differs in its unisexual flowers with shorter corolla lobes, and *G. rosea* differs in its 1- to 3-flowered and fasciculate inflorescences. In areas where *G. walkeri* and *G. ternifolia* grow sympatrically (e.g., Adam's Peak), the natural hybrid *G. ×gardneri* occasionally occurs. *Gaertnera ×gardneri* differs from *G. walkeri* in having mixed opposite and ternate leaves and ridged internodes.

The lectotype was originally designated as a specimen at GL in the G. A. Walker Arnott herbarium, but this collection has been moved to E.

Representative specimens examined. SRI LANKA. **Kandy Distr.:** Knuckles, Madulkelle, *Kostermans 25017* (A, BM, K, L, PDA). **Matara Distr.:** North Enselwatte, Sinharaja, *Sohmer 10461* (GH, K, MO), *Waas 1483* (K, MO, PDA). **Nuwara Eliya Distr.:** Peak Wilderness National Park, lower slopes Adam's Peak, *Malcomber 2764* (MO, PDA), *2765* (MO, PDA). **Ratnapura Distr.:** Dotalugala Forest, *Waas 1840* (E, L, MO).

NAMES OF UNKNOWN IDENTITY

Frutesca mauritiana DC. ex Meisn., Pl. Vasc. Gen. 1: 259, 2: 168. 1840. TYPE: Mauritius, not designated.

As discussed in the introduction, this name applies to a species of *Gaertnera* from Mauritius, but which species is unclear.

Gaertnera boivinii Drake, Bull. Soc. Bot. France, 45: 354. 1898 [1899]. TYPE: Mauritius. s. loc., *Boivin s.n.* (holotype, P not located).

Neither the Boivin specimen nor any other specimens annotated by Drake with this name have been located and the description is inadequate, thus the identity of this name is unknown.

Gaertnera borneensis Valetton, Bot. Jahrb. Syst. 44: 568. 1910. TYPE: Borneo. Betw. Buntok & Djihi, *Winkler 3321* (holotype, BO not seen).

This name was treated as a synonym of *Gaertnera vaginans* subsp. *junghuhniana* by van Beusekom (1967). However, no specimens identified with this name by Valetton have been seen, and *G. junghuhniana* is circumscribed much more narrowly here than by van Beusekom. The description suggests that this

species probably falls within *G. junghuhniana* as circumscribed here, but because of the complicated morphological patterns in this group, this placement needs to be confirmed with the study of specimens.

Gaertnera chapelieri Drake, Bull. Soc. Bot. France 45: 355. 1898 [1899]. TYPE: Madagascar. s. loc., *Chapelier s.n.* (holotype, P not located).

Neither the Chapelier specimen nor any other specimens annotated by Drake with this name have been located and the description is inadequate, thus the identity of this name is unknown.

Gaertnera longiflora C. F. Gaertn., Suppl. Carp. 59, t. 191, fig. 1. 1806. TYPE: Madagascar. s. loc., *Commerson s.n.* (holotype, TUB not seen).

This species is described and illustrated as having an irregularly, distinctly lobed calyx, ellipsoid-ovoid fruits, well-developed bracteoles, and flowers and fruits variously sessile to shortly pedicellate. No specimen has been seen that can be connected conclusively to this name, and its identity is unclear.

Gaertnera oxycarpa Drake, Bull. Soc. Bot. France 45: 354. 1898 [1899]. TYPE: probably Mauritius. s. loc., *Dupetit-Thouars s.n.* (holotype, P not located).

Neither the Dupetit-Thouars specimen nor any other specimens annotated by Drake with this name have been located and the description is inadequate, thus the identity of this name is unknown.

Gaertnera stictophylla (Hiern) E. M. A. Petit, Bull. Jard. Bot. État Bruxelles 29: 382. 1959. Basionym: *Psychotria stictophylla* Hiern, in Oliver, Fl. Trop. Afr. 3: 212. 1877. TYPE: Gabon. Estuaire: Sierra del Crystal Mtns., 1862, *Mann 1721* (holotype, K photo!).

Only a photograph of the type specimen at Kew has been seen. The identity of this species, including its generic placement, is difficult to confirm because the stipules on the type specimen are poorly conserved and the inflorescence is immature. Petit (1959b) was also unsure of the identity of this species, which he said seemed to him similar to *Gaertnera liberiensis* but apparently lacks the distinctive stipules of that species.

Gaertnera thouarsii Baill., Bull. Mens. Soc. Linn. Paris 1: 209. 1879, nom. nud. TYPE: Mauritius. *P. Dupetit-Thouars s.n.* (holotype, P not located).

This name was published with no description at all, simply the explicit citation of the name and Baillon's intent to name a species, and the comment that the name is based on a specimen of Dupetit-Thouars that is found in several herbaria and variously identified as

Psychotria in some and *Gaertnera* in others. No specimens with this name have been located, and its identity is unclear.

Sykesia lanceolata Kuntze, Revis. Gen. Pl. 2: 425. 1891, nom. nud.

This name was published in Kuntze's summary of *Sykesia*, the name he used to replace *Gaertnera*, which he knew to be a later homonym. This *Sykesia* name appears in a list of new nomenclatural combinations for species previously treated in *Gaertnera* and was said to be based on a *Gaertnera* name published by Bojer, but that previously published name has not been found. Kuntze may have intended to reference and make a new combination for *G. lanceolata* Bouton ex A. DC., which is otherwise not listed by him, but he did not identify the basionym well enough to exclude any names published in other genera with the same epithet by Bojer, so the identity of this is not clear.

EXCLUDED NAMES

Several names listed here were published in different, homonymic genera also named *Gaertnera*, which belong to other families as noted. Several names published in the essentially homonymic genus *Gaertneria* (Asteraceae) are not listed here, although they have sometimes been misspelled as "*Gaertnera*."

Gaertnera australiana C. T. White, Proc. Roy. Soc. Queensland 53: 223. 1942 [– *Psychotria* sp. (van Beusekom, 1967)].

Gaertnera capitata Bojer, Hortus Maurit. 216. 1837 [– *Chassalia capitata* DC. (Verdcourt, 1989; he considers these two different names, based on two different types)].

Gaertnera caerulea Bojer, Hortus Maurit. 217. 1837. *Gaertnera coerulea*, orth. var., cf. A. DC., Prodr. 9: 35. 1845 [– *Chassalia grandifolia* DC. (Verdcourt, 1989, as "*G. coerulea*")].

Gaertnera cymiflora Bojer, Hortus Maurit. 218. 1837 [– *Chassalia boryana* DC. (Verdcourt, 1989)].

Gaertnera ferruginea A. Chev., Explor. Bot. Afrique Occ. Franc. 1: 444. 1920, nom. nud. [– *Premna quadrifolia* Schumach. & Thonn., Verbenaceae (Petit, 1959a)].

Gaertnera hongkongensis Seem., Bot. Voy. Herald 384. 1857. *Sykesia hongkongensis* (Seem.) Kuntze, Revis. Gen. Pl. 2: 425. 1891. *Tsiangia hongkongensis* (Seem.) P. P. H. But, H. H. Hsue & P. T. Li, Blumea 31(2): 311. 1986 [– *Ixora chinensis* Lam. (Bridson, 2000)].

Gaertnera incarnata Bojer, Hortus Maurit. 217. 1837 [– *Chassalia lanceolata* (Poir.) A. Chev. subsp. *lanceolata* (Verdcourt, 1983)].

Gaertnera indica J. F. Gmel., Syst. Nat., ed. 13[bis], 2(1): 685. 1791 [– *Hiptage madablota* Gaertn., Malpighiaceae (Steudel, 1840)].

Gaertnera lasianthoides C. E. C. Fisch., Bull. Misc. Inform. Kew 1927: 209. 1927 [– *Psychotria rhinocerotis* Blume (van Beusekom, 1967)].

Gaertnera longipetiolata R. D. Good, J. Bot. 67(Suppl. 2): 105. 1929 [– *Psychotria gossweileri* E. M. A. Petit (Petit, 1959a, b)].

Gaertnera lushaiensis C. E. C. Fisch., Bull. Misc. Inform. Kew 1928: 411. 1928 [– *Chassalia lushaiensis* (C. E. C. Fisch.) C. E. C. Fisch., Bull. Misc. Inform. Kew 1931: 282. 1931].

Gaertnera morindoides Baker, Bull. Misc. Inform. Kew 1892: 83. 1892 [– *Morinda morindoides* (Baker) Milne-Redh. (Petit, 1959a)].

Gaertnera obtusifolia (DC.) Roxb., Fl. Ind., ed. 1832, 2: 369. 1832 [– *Hiptage obtusifolia* (Roxb.) DC. (Steudel, 1840)].

Gaertnera pangati Rheede ex Retz., Observ. Bot. 6: 24. 1791. *Gaertnera pongatii*, orth. var. [– *Sphenoclea zeylanica* Gaertn., Campanulaceae or Lobeliaceae (Steudel, 1840)].

Gaertnera racemosa (Cav.) Roxb., Pl. Coromandel 1: 19, t. 18. 1795. Basionym: *Molina racemosa* Cav., Diss. 9: 435, t. 263. 1790 [– *Hiptage benghalensis* (L.) Kurz, Malpighiaceae (Jacobs, 1955)].

Gaertnera richardii Drake, Bull. Soc. Bot. France 45: 355. 1898 [1899] [probably – *Psychotria* sp.].

No adequate material is available to confirm the identity of this species, but syntype specimens *J. M. C. Richard* 236 and *J. M. C. Richard* 657 (both P!) dry with a red-brown cast and have distinct marginal leaf veins that are characteristic of *Psychotria*.

Gaertnera rufinervis Stapf, Trans. Linn. Soc. London, Bot. 4: 183. 1894 [– *Psychotria* sp. (van Beusekom, 1967)].

Gaertnera violascens Ridl., J. Fed. Malay States Mus. 6: 164. 1915 [– *Psychotria* sp. (van Beusekom, 1967)].

Gaertnera zimmermannii K. Krause & Gilg, Bot. Jahrb. Syst. 48: 430. 1912 [– *Strychnos* sp., Loganiaceae (Petit, 1959a)].

Literature Cited

- Andersson, L. 1998. A revision of the genus *Cinchona* (Rubiaceae–Cinchoneae). Mem. New York Bot. Gard. 80: 1–75.
- & J. H. E. Rova. 1999. The *rps16* intron and the phylogeny of the *Rubioideae* (Rubiaceae). Pl. Syst. Evol. 214: 161–186.
- Anonymous. 1997. Mauritius endemic tree refound. Pl. Talk 8: 18.

- Arnott, G. A. W. 1836. *Pugillus Plantarum Indiae Orientalis*. Academia Caesararum Leopoldino-Carolinae, Breslau.
- Baillon, H. E. 1879. Sur les *Gaertnera* et la valeur du groupe des Gaertnerées. *Bull. Mens. Soc. Linn. Paris* 1: 209–210.
- Baker, J. G. 1877. Loganiaceae. *Flora of Mauritius and the Seychelles*. Lovell Reeve & Co., London.
- Baum, D. A., K. J. Sytsma & P. C. Hoch. 1994. A phylogenetic analysis of *Epilobium* (Onagraceae) based on nuclear ribosomal DNA sequences. *Syst. Biol.* 47: 181–207.
- Bentham, G. 1857. Notes on Loganiaceae. *J. Proc. Linn. Soc., Bot.* 1: 52–113.
- & J. D. Hooker. 1876. *Genera Plantarum*, Vol. 2, Part 2. Lovell Reeve & Co., London.
- Blume, C. L. 1850. *Museum Botanicum*. E. J. Brill, Leiden.
- Bojer, W. 1837. *Hortus Mauritanus*. Aimé Mamarot, Mauritius.
- Bremekamp, C. E. B. 1954. Les sous-familles et les tribus des Rubiacées. *Huitième Congrès International de Botanique, Paris, Rapports et Communications*, sect. 4: 113–114.
- . 1966. Remarks on the position, the delimitation and subdivision of the Rubiaceae. *Acta Bot. Neerl.* 15: 1–33.
- Bremer, B. 1996. Phylogenetic studies within Rubiaceae and relationships to other families based on molecular data. *Opera Bot. Belg.* 7: 33–50.
- & J. F. Manen. 2000. Phylogeny and classification of the subfamily Rubioideae (Rubiaceae). *Pl. Syst. Evol.* 225(1–4): 43–72.
- Bridson, D. M. 2000. The identity of *Tsiangia* (Rubiaceae). *Kew Bull.* 55(4): 1011–1012.
- Brown, R. 1814. General remarks, geographical and systematical, on the botany of Terra Australis. Pp. 533–613 in M. Flinders (editor), *A Voyage to Terra Australis*, Vol. I. G. & W. Nicol, London.
- . 1818. Observations, systematical and geographical, on Professor Christian Smith's Collection of Plants from the Vicinity of the River Congo. Pp. 420–485 in J. H. Tuckey (editor), *Narrative of an Expedition to Explore the River Zaire, Usually Called the Congo, in South Africa, in 1816, under the direction of Captain J.K. [sic] Tuckey*. John Murray, London.
- Buckler, E. S., A. Ippolito & T. P. Holtsford. 1997. The evolution of ribosomal DNA: Paralogues and phylogenetic implications. *Genetics* 145: 821–832.
- Candolle, A. de. 1830. *Prodromus Systematis Naturalis Regni Vegetabilis*, Vol. 4. Treuttel & Wertz, Paris.
- Candolle, A. P. de. 1845. *Prodromus Systematis Naturalis Regni Vegetabilis*, Vol. 9. Fortin, Masson & Soc., Paris.
- Cronk, Q. C. B. 1998. The ochlopecies concept. Pp. 155–170 in C. R. Huxley, J. M. Lock & D. F. Cutler (editors), *Chorology, Taxonomy and Ecology of the Floras of Africa and Madagascar*. Royal Botanical Gardens, Kew, Richmond.
- Dallwitz, M. J., T. A. Paine & E. J. Zurcher. 1999. *User's Guide to the DELTA System: A General System for Processing Taxonomic Descriptions*, 4th ed. <<http://delta-intkey.com>>, accessed 13 July 2009.
- Davis, A. P. & D. Bridson. 2003. Introduction to the Rubiaceae. Pp. 431–434 in S. M. Goodman & J. P. Benstead (editors), *The Natural History of Madagascar*. University of Chicago Press, Chicago.
- De Coudomoy, E. J. 1893. *Flore de l'Île de la Réunion*. Paul Klincksieck, Paris.
- Delprete, P. G. 1996. Notes on calycophyllous Rubiaceae. Part I. Morphological comparisons of the genera *Chimarrhis*, *Bathysa*, and *Calycophyllum*, with new combinations and a new species, *Chimarrhis gentryana*. *Brittonia* 48(1): 35–44.
- De Queiroz, K. 1998. The general lineage concept of species, species criteria, and the process of speciation: A conceptual unification and terminological recommendations. Pp. 57–75 in D. J. Howard & S. H. Berlocher (editors), *Endless Forms: Species and Speciation*. Oxford University Press, New York.
- . 1999. The general lineage concept of species, and the defining properties of the species concept. Pp. 49–89 in R. A. Wilson (editor), *Species: New Interdisciplinary Essays*. MIT Press, Cambridge, Massachusetts.
- Dorr, L. 1997. *Plant Collectors in Madagascar and the Comoro Islands*. Royal Botanical Gardens, Kew, Richmond.
- Doyle, J. J. & J. L. Doyle. 1987. A rapid isolation procedure for small quantities of fresh leaf tissue. *Phytochem. Bull.* 19: 11–15.
- Drake, E. 1899. Note sur deux genres de Rubiacées des Îles de l'Afrique orientale. *Bull. Soc. Bot. France* 45: 344–356.
- Du Puy, D. J. & J. Moat. 1998. Vegetation mapping of classification in Madagascar (using GIS): Implications and recommendations for the conservation of biodiversity. Pp. 97–177 in C. R. Huxley, J. M. Lock & D. F. Cutler (editors), *Chorology, Taxonomy and Ecology of the Floras of Africa and Madagascar*. Royal Botanical Gardens, Kew, Richmond.
- & ———. 2003. Using geological substrate to identify and map primary vegetation types in Madagascar and the implications for planning biodiversity conservation. Pp. 51–67 in S. M. Goodman & J. P. Benstead (editors), *The Natural History of Madagascar*. University of Chicago Press, Chicago.
- Endlicher, S. 1838. *Genera Plantarum Secundum Ordines Naturales*. Fr. Beck, Wien.
- Fischer, C. E. C. 1927. XXVII. Contributions to the Flora of Burma: III. *Bull. Misc. Inform. Kew* 1927: 203–212.
- . 1928. XXIII. Decades Kewenses, Plantarum Novarum in Herbario Horti Regii Conservatarum: Decas CXX. *Bull. Misc. Inform. Kew* 1928: 141–147.
- Friis, I. 1998. Frank White and the development of African chorology. Pp. 25–52 in C. R. Huxley, J. M. Lock & D. F. Cutler (editors), *Chorology, Taxonomy and Ecology of the Floras of Africa and Madagascar*. Royal Botanical Gardens, Kew, Richmond.
- Gaertner, C. F. 1806. *Supplementum carpologiae: Seu continuati operis Josephi Gaertner de Fructibus et seminibus plantarum*. C. F. E. Richter, Leipzig.
- Gautier, L. & S. M. Goodman. 2003. Introduction to the flora of Madagascar. Pp. 229–250 in S. M. Goodman & J. P. Benstead (editors), *The Natural History of Madagascar*. University of Chicago Press, Chicago.
- Groeninckx, I., A. Vrijdaghs, S. Huysmans, E. Smets & S. Desein. 2007. Floral ontogeny of the Afro-Madagascan genus *Mitrasacmopsis* with comments on the development of superior ovaries in Rubiaceae. *Ann. Bot.* 100: 41–49.
- Hamilton, C. W. 1989. A revision of Mesoamerican *Psychotria* subg. *Psychotria* (Rubiaceae). *Ann. Missouri Bot. Gard.* 76: 67–111, 386–429, 886–916.
- Huelsenbeck, J. P. & F. Ronquist. 2001. MrBayes: Bayesian inference of phylogeny. *Bioinformatics* 17: 754–755.
- Hutchinson, J. & J. M. Dalziel. 1931. *Flora of West Tropical Africa*. Crown Agents, London.
- & ———. 1937. Tropical African plants XV. *Kew Bull.* 1937: 62–63.
- Igersheim, A., C. Puff, P. Leins & C. Erbar. 1994. Gynoecial development of *Gaertnera* Lam. and of presumably allied taxa of the Psychotrieae (Rubiaceae): Secondarily “superior” vs. inferior ovaries. *Bot. Jahrb. Syst.* 116: 401–414.

- IUCN. 2001. IUCN Red List Categories and Criteria, Version 3.1. Prepared by the IUCN Species Survival Commission. IUCN, Gland, Switzerland, and Cambridge, United Kingdom.
- Jacobs, M. 1955. Malpighiaceae. Flora Malesiana, ser. 1, Spermatophyta 5: 125–143.
- Jansen, S., E. Robbrecht & E. Smets. 1996a. The systematic value of endexine ornamentation in some Psychotrieae pollen (Rubiaceae–Rubioidae). Grana 35: 129–137.
- , ———, H. Beeckman & E. Smets. 1996b. *Gaertnera* and *Pagamea*: Genera within the Psychotrieae or constituting the tribe Gaertnereae? A wood anatomical and palynological approach. Bot. Acta 109: 466–476.
- , ———, ——— & ———. 1997. Wood anatomy of the predominantly African representatives of the tribe Psychotrieae (Rubiaceae–Rubioidae). Int. Assoc. Wood Anat. J. 18: 169–196.
- Jussieu, A.-L. de. 1807. Sur les caractères généraux des familles, tirés des graines, et confirmés ou rectifiés par les observations de Gaertner. Ann. Mus. Hist. Nat. 10: 307–332.
- Klett, W. 1924. Umfang und Inhalt der Familie der Loganiaceen. Bot. Arch. 5: 312–338.
- Kuntze, O. 1891. Revisio generum plantarum: Vascularium omnium atque cellularium multarum secundum leges nomenclaturae internationales cum enumeratione plantarum exoticarum in itinere mundi collectarum, Vol. 2. A. Félix, Leipzig.
- Lamarck, J. B. A. P. M. de. 1792. Tableau Encyclopédique et Méthodique des Trois Règnes de la Nature, Vol. 1. Panckoucke, Paris.
- Lawrence, G. H. M. 1951. Taxonomy of Vascular Plants. Macmillan Co., New York.
- Maddison, D. R. & W. P. Maddison. 2003. MacClade: Analysis of Phylogeny and Character Evolution. Sinauer Associates, Sunderland, Massachusetts.
- Malcomber, S. T. 2000. Systematics and Evolution of Breeding Systems in *Gaertnera* (Rubiaceae). Ph.D. Dissertation, Washington University, St. Louis.
- . 2002. Phylogeny of *Gaertnera* Lam. (Rubiaceae) based on multiple DNA markers: Evidence of a rapid radiation in a widespread, morphologically diverse genus. Evolution 56(1): 42–57.
- & A. P. Davis. 2005. Six new species of *Gaertnera* (Rubiaceae) from Madagascar and phylogenetic analyses that support *Hymenocnemis* as a synonym of *Gaertnera*. Monogr. Syst. Bot. Missouri Bot. Gard. 104: 371–398.
- Maldonado, G. C. B. 2005. A Revision of the Genus *Elaeagia* (Rubiaceae). Thesis, Department of Systematic Botany, University of Aarhus, Aarhus.
- McNeil, J., F. R. Barrie, H. M. Burdet, V. Demoulin, D. L. Hawksworth, K. Marhold, D. H. Nicolson, J. Prado, P. C. Silva, J. E. Skog, J. H. Wiersema & N. J. Turland (editors). 2006. International Code of Botanical Nomenclature (Vienna Code). Regnum Veg. 146.
- Merrill, E. D. 1921. A bibliographic enumeration of Bornean plants. J. Straits Branch R. Asiat. Soc., special number, 1–637.
- Mishler, B. D. 1999. Getting rid of species? Pp. 307–315 in R. A. Wilson (editor), Species: New Interdisciplinary Essays. MIT Press, Cambridge, Massachusetts.
- Muenchow, G. E. & M. Grebus. 1989. The evolution of dioecy from distyly: Reevaluation of the hypothesis of the loss of long-tongued pollinators. Amer. Naturalist 133: 149–156.
- Nepokroeff, M., B. Bremer & K. Sytsma. 1999. Reorganization of the genus *Psychotria* and the tribe Psychotrieae (Rubiaceae) inferred from ITS and *rbcL* sequence data. Syst. Bot. 24: 5–27.
- Petit, E. 1959a. Les *Gaertnera* Lam. (Rubiaceae) de l'Afrique tropicale et spécialement du Congo belge. Bull. Jard. Bot. État Bruxelles 29: 37–53.
- . 1959b. Historique de la position systématique de *Gaertnera* Lam. et remarques sur quelque espèces Africaines du genre. Bull. Jard. Bot. État Bruxelles 29: 377–383.
- . 1962. Rubiaceae Africanae IX. Notes sur les genres *Aidia*, *Atractogyne*, *Aulacocalyx*, *Batopedina*, *Gaertnera*, *Morinda*, *Mussaenda*, *Nauclea*, *Sabicea*, *Schizocolea* et *Tricalysia*. Bull. Jard. Bot. État Bruxelles 32: 173–198.
- Piesschaert, F. 2001. Carpology and Pollen Morphology of the Psychotrieae (Rubiaceae–Rubioidae), Towards a New Tribal and Generic Delimitation. Dissertation, Catholic University of Leuven, Leuven, Belgium.
- , S. Jansen, I. James, E. Robbrecht & E. Smets. 2001. Morphology, anatomy, and taxonomic position of *Pagameopsis* (Rubiaceae–Rubioidae). Brittonia 33: 490–504.
- Posada, D. & K. A. Crandall. 1998. MODELTEST: Testing the model of DNA substitutions. Bioinformatics 14: 817–818.
- Ridley, H. N. 1908. On a collection of plants made by H. C. Robinson and L. Wray from Gunong Tahan, Pehang. J. Linn. Soc., Bot. 38: 301–336.
- . 1915. Plants from Gunong Kerbau, Perak. J. Fed. Malay States Mus. 4: 43–62.
- . 1934. Contributions towards a Flora of British North Borneo, IV. Kew Bull. 1934: 119–124.
- Robbrecht, E. 1988. Tropical woody Rubiaceae. Opera Bot. Belg. 1: 1–271.
- . 1996. Generic distribution patterns in Subsaharan African Rubiaceae (Angiospermaceae). J. Biogeogr. 23: 311–328.
- & J.-F. Manen. 2006. The major evolutionary lineages of the coffee family (Rubiaceae, angiosperms). Combined analysis (nDNA and cpDNA) to infer the position of *Coptosapelta* and *Luculia*, and supertree construction based on *rbcL*, *rps16*, *trnL-trnF* and *atpB-rbcL* data. A new classification in two subfamilies, Cinchonoideae and Rubioidae. Syst. Geogr. Pl. 76: 85–146.
- Roemer, J. J. & J. A. Schultes. 1819. Systema Vegetabilium, Vol. 5. J. G. Cott, Stuttgart.
- Sambrook, J. C., E. F. Fritsch & T. Maniatis. 1989. Molecular Cloning: A Laboratory Manual. Cold Spring Harbor Press, New York.
- Schumann, K. 1891. Rubiaceae. Pp. 1–156 in A. Engler & K. Prantl (editors), Die Natürlichen Pflanzenfamilien, IV, Teil, 4 Abteilung. W. Engelmann, Leipzig.
- Solereder, G. H. 1890. Studien über die Tribus Gaertnereen Benth. Hook. Ber. Deutsch. Bot. Ges. 8, Gen.-Versamml.: 70–100.
- Stafleu, F. A. & R. S. Cowan. 1986. Taxonomic Literature, 2nd ed., Vol. VI: Sti–Vuy. Regnum Veg. 115: 1–926. Bohn, Scheltema & Holkema, Utrecht.
- Steudel, E. G. 1840. Nomenclator botanicus, seu: Synonymia plantarum universalis... Vol. 1. J. G. Cott, Stuttgart.
- Takhtajan, A. 1986. Floristic Regions of the World. University of California Press, Berkeley.
- Taylor, C. M., J. A. Steyermark, P. G. Delprete, A. Vicentini, R. Cortés, D. Zappi, C. Persson, C. B. Costa & E. A. da Anunciação. 2004. Rubiaceae. Pp. 497–847 in J. A.

- Steyermark, P. E. Berry, K. Yatskievych & B. K. Holst (editors), *Flora of the Venezuelan Guayana*, Vol. 8. Missouri Botanical Garden Press, St. Louis.
- Thompson, J., T. Gibson & D. Higgins. 1994. Clustal W, Vers. 1.7: Improving the sensitivity of progressive multiple sequence alignment through sequence weighting, positions-specific gap penalties and weight matrix choice. *Nucl. Acids Res.* 22: 4673–4680.
- van Beusekom, C. F. 1967 [1968]. A revision of the Malesian and Ceylonese species of the genus *Gaertnera* Lamk. (Rubiaceae). *Blumea* 15: 359–391.
- Vegter, I. H. 1976. Index Herbariorum Part II(4), Collectors M. *Regnum Veg.* 93: 475–576. Bohn, Scheltema & Holkema, Utrecht.
- . 1983. Index Herbariorum Part II(5), Collectors N–R. *Regnum Veg.* 109: 577–803.
- . 1988. Index Herbariorum Part II(7), Collectors T/t/m. *Regnum Veg.* 117: 987–1213.
- Verdcourt, B. 1958. Remarks on the classification of the Rubiaceae. *Bull. Jard. Bot. État Bruxelles* 28: 209–290.
- . 1983. Notes on Mascarene Rubiaceae. *Kew Bull.* 37: 521–574.
- . 1989. 108. Rubiaceae. Pp. 1–133 in J. Bosser, T. Cadet, J. Guelho & W. Maras (editors), *Flore des Mascareignes, La Réunion, Maurice, Rodrigues*. Sugar Industry Research Institute, Port Louis, Mauritius.
- Vicentini, A. 2007. *Pagamea* Aubl. (Rubiaceae), from Species to Processes, Building the Bridge. Ph.D. Dissertation, University of Missouri–St. Louis, St. Louis.
- Vink, W. 1970. The Winteraceae of the Old World. I. *Pseudowintera* and *Drimys*—Morphology and taxonomy. *Blumea* 18: 225–354.
- Walter, K. S. & H. J. Gillett. 1998. 1997 IUCN Red List of Threatened Plants. IUCN, Gland, Switzerland.
- Weberling, F. 1977. Beiträge zur Morphologie der Rubiaceae-Infloreszenzen. *Ber. Deutsch. Bot. Ges.* 90: 191–209.
- White, F. 1993. The AETFAT chorological classification of Africa: History, methods and applications. *Bull. Jard. Bot. Nat. Belg.* 62: 225–281.
- . 1998. The vegetative structure of African Ebenaceae and the evolution of rheophytes and ring species. Pp. 95–113 in H. C. F. Hopkins, C. R. Huxley, C. M. Pannell, G. T. Prance & F. White (editors), *The Biological Monograph*. Royal Botanical Gardens, Kew, Richmond.
- White, T. J., T. Bruns, S. Lee & J. Taylor. 1990. Amplification and direct sequencing of fungal ribosomal RNA genes for phylogenetics. Pp. 315–322 in M. A. Innis, D. H. Gelfand, J. J. Sninsky & T. J. White (editors), *PCR Protocols: A Guide to Methods and Applications*. Academic Press, San Diego.
- Appendix 1. Index to numbered collections.
- Specimens are listed alphabetically according to the principal collector, with unknown collectors excluded. Numbers in parentheses correspond to the number of the species in the text and in the List of Species below. Asterisks indicate type collections. Dorr (1997) presented additional information on many collectors in Madagascar. Some collectors use only one name and therefore have no initials; others without initials here have not been traced.
- LIST OF *GAERTNERA* SPECIES AND VARIETIES RECOGNIZED IN THIS REVISION
1. *Gaertnera alata* Bremek. ex Malcomber & A. P. Davis
 2. *Gaertnera alstonii* Malcomber
 3. *Gaertnera aphanodioica* Malcomber
 4. *Gaertnera arenaria* Baker
 5. *Gaertnera aurea* Malcomber
 6. *Gaertnera bambusifolia* Malcomber & A. P. Davis
 7. *Gaertnera belumutensis* Malcomber
 8. *Gaertnera bieleri* (De Wild.) E. M. A. Petit
 9. *Gaertnera brevipedicellata* Malcomber & A. P. Davis
 10. *Gaertnera calycina* Bojer
 11. *Gaertnera capitulata* Malcomber
 12. *Gaertnera cardiocarpa* Boivin ex Baill.
 13. *Gaertnera cooperi* Hutch. & M. B. Moss
 14. *Gaertnera crassiflora* Bojer
 15. *Gaertnera cuneifolia* Bojer
 16. *Gaertnera darcyana* Malcomber & A. P. Davis
 17. *Gaertnera divaricata* (Thwaites) Thwaites
 18. *Gaertnera diversifolia* Ridl.
 19. *Gaertnera drakeana* Aug. DC.
 20. *Gaertnera edentata* Bojer
 21. *Gaertnera eketensis* Wernham
 22. *Gaertnera fractiflexa* Beusekom
 23. *Gaertnera furcellata* (Baill. ex Vatke) Malcomber & A. P. Davis
 24. *Gaertnera gabonensis* Malcomber
 25. *Gaertnera* × *gardneri* Thwaites
 26. *Gaertnera globigera* Beusekom
 27. *Gaertnera grisea* Hook. f. ex C. B. Clarke
 28. *Gaertnera guillotii* Hochr.
 29. *Gaertnera hirtiflora* Verdc.
 30. *Gaertnera hispida* Aug. DC.
 31. *Gaertnera humblotii* Drake
 32. *Gaertnera ianthina* Malcomber
 33. *Gaertnera inflexa* Baill.
 34. *Gaertnera junghuhniana* Miq.
 35. *Gaertnera kochummenii* Malcomber
 36. *Gaertnera letouzeyi* Malcomber
 37. *Gaertnera leucothyrsa* (K. Krause) E. M. A. Petit
 38. *Gaertnera liberiensis* E. M. A. Petit
 39. *Gaertnera longifolia* Bojer
 40. *Gaertnera longivaginalis* (Schweinf. ex Hiern) E. M. A. Petit
 - 40a. *Gaertnera longivaginalis* var. *bracteata* (E. M. A. Petit) Malcomber
 - 40b. *Gaertnera longivaginalis* (Schweinf. ex Hiern) E. M. A. Petit var. *longivaginalis*
 41. *Gaertnera lowryi* Malcomber
 42. *Gaertnera macrobotrys* Baker
 43. *Gaertnera macrostipula* Baker
 44. *Gaertnera madagascariensis* (Hook. f.) Malcomber & A. P. Davis
 45. *Gaertnera microphylla* Capuron ex Malcomber & A. P. Davis
 46. *Gaertnera monstrosa* Malcomber
 47. *Gaertnera obesa* Hook. f. ex C. B. Clarke
 48. *Gaertnera oblanceolata* King & Gamble
 49. *Gaertnera obovata* Baker
 - 49a. *Gaertnera obovata* Baker var. *obovata*
 - 49b. *Gaertnera obovata* var. *sphaerocarpa* (Baker) Malcomber
 50. *Gaertnera paniculata* Benth.
 51. *Gaertnera pauciflora* Malcomber & A. P. Davis
 52. *Gaertnera pendula* Bojer
 53. *Gaertnera phanerophlebia* Baker
 54. *Gaertnera phyllosepala* Baker
 55. *Gaertnera phyllostachya* Baker
 56. *Gaertnera psychotrioides* (DC.) Baker
 57. *Gaertnera ramosa* Ridl.
 58. *Gaertnera raphaelii* Malcomber

59. *Gaertnera rosea* Thwaites ex Benth.
60. *Gaertnera rotundifolia* Bojer
61. *Gaertnera schatzii* Malcomber
62. *Gaertnera schizocalyx* Bremek.
63. *Gaertnera spicata* K. Schum.
64. *Gaertnera sralensis* (Pierre ex Pit.) Kerr
65. *Gaertnera ternifolia* Thwaites
66. *Gaertnera trachystyla* (Hiern) E. M. A. Petit
67. *Gaertnera vaginans* (DC.) Merr.
68. *Gaertnera vaginata* Lam.
69. *Gaertnera viminea* Hook. f. ex C. B. Clarke
70. *Gaertnera walkeri* (Arn.) Blume

Abang Mohtar S 41768 (18), S 52719 (18); Abraham, J. P. SF25874 (49a), SF7811 (42), SF7997 (49b); Abu Nawas A 834 (34); Adam MAU 11606 (56); Adam, J.-G. 124 (40b), 3658 (40b), 4697 (40a), 5997 (50), 6043 (50), 16307 (13), 20579 (40b), 22252 (50), 22405 (50), 27518 (40b), 28771 (40a), 28815 (50), 29544 (50), 29749 (50), 29876 (50); Adames, P. 568 (50); Aké Assi, L. 654 (5), 673 (5), 15130 (50), 15881 (5), 17797 (13), 19063 (50); Akondrovao SF 26415 (58); Alphonse [no initial; Dorr, 1997] RN 8677 (49a); Alston, A. 13252 (2); Amin, G. 86356 (34), SAN 95125* (2), SAN 97444 (34); Anderson, J. A. R. 8356 (34), SAR 9863* (26); Anderson, J. W. 19 (48); Andrianansata 158 (31); Armand, W. 6 (49b), 26 (58); Armange [no initial] 15 (68); Ashton, P. S. BRUN 165 (34), 192 (18), 916 (65), 16599 (18), 17970 (34); Asonganyi 161 (66), 34 (40b); Attie 11 (68); Aubréville, D. 81 (50), 1134 (50), 733 (50); Audru, J. 29996 (50).

Badré, F. J. 763 (68); Bakshi 184 (40a); Balakrishnan, N. 528 (17), 548 (65), 969 (67); Baldwin, J. T. 9833 (50), 10797 (13), 10928 (13), 11121 (13), 11554 (50), 13057 (50); Bamps, P. 379 (40b), 2041 (5), 2263 (40b); Barker 1267 (13); Barkly 536 (68), 630 (68), 1156 (56), 1374 (56); Barnes, E. SING 10889 (57); Baron, R. 149* (49a), 158 (44), 366 (44), 400 (44), 800 (42), 1233* (49b), 1243* (49b), 1267 (44), 1290 (54), 1328 (44), 1352 (44), 1533 (55), 1920* (54), 1922* (43), 1945* (42), 2217 (44), 2327* (55), 2372* (53), 2406 (31), 2683 (55), 2982* (53), 5010 (31), 5956 (42), 5958 (42); Bates, G. 516* (66), B10584 (34); Beaman, J. 8215 (18), 8271 (18); Beaujard [initial unknown; Dorr, 1997] 183 (42), 184 (43), 387 (42); Beccari, P. B. 1799* (62); Beddome, R. H. 5309 (70), 5310 (70); Beentje, H. 568 (5); Béjué 2971 (5); Bélanger, C.-P. 5A (39), 101 (14); Bellay, G. du 232* (50); Benoist, R. 297 (49a), 1520 (42); Bequaert, J. 106 (40b), 176 (13), 186 (50), 6870 (8); Bernardi, A. L. 11097 (49a), 11535 (58), 14503 (68), 14536 (68), 14714 (56), 14740 (56), 14778 (56), 14794 (20), 14794B (56), 14977 (68), 15035 (68), 15989 (65); Best, G. A. 7850 (47); Bijoux, F. M. MAU 1094 (60), MAU 1627 (10), MAU 2734 (52), MAU 2753 (10); Billiet 437 (68), 452 (68), 479 (68), 563 (68), 832 (68); Birkill, SING 234 (47); Birkinshaw, C. 117 (4), 296 (49b); Blackburn, E. B. 3370 (10); Boivin, L.-H. 1219 (68), 1778* (33), 1779 (43), 1780* (53), 2074* (4); Bojer, W. 68 (52); Bos, J. J. 2026 (13), 2984 (13), 3166 (66), 3982 (66), 4429 (66), 5358 (66), 5766 (66), 6340 (8), 6570 (66); Bosser, J.-M. 182 (49b), 6722 (44), 8200 (44), 9453 (68), 11621 (68), 12839 (44), 14413 (49b), 20811 (68); Botoalina, M. RN 3192 (53), RN 3734 (31), RN 6077 (54); Bouet, Dr. 8 (63); Boukouko Station Team 330 (50), 1974 (50); Bouton, L. S. MAU 1080 (20), 1085 (52); Boyer, G. 59 (68); Bremer, B. 895 (59), 1006 (65), 1051 (70); Brenan, J. 8934 (50); Breteler, F. 344 (66), 382 (66), 389 (63), 1626 (40b), 5458 (40a), 5533 (50), 5974 (50), 6275 (50), 7651 (40b), 8029 (24), 10214 (24), 12496 (40b); Breyne 94 (50), 3081 (40a), 3417 (40a); Brown, R. C. 958 (50); Brummitt, R. 13918 (50); Bünnemeyer, H. A. B. 1995 (27), 6512 (27),

7686 (34); Burgess FRI 9100 (18); Burkill, I. 52 (18), 136 (69), 1895 (47), SING 7613 (27), 7823 (18), 8521 (18), 8608* (18), 12902 (48); Burley 1157 (34), 3066 (34); Burt, B. D. 88 (65); Buwalda, P. 6680 (34).

Cadet, L. J. T. 54 (68), 592 (68), 698 bis (68), 1179 (68), 3814 (68), 3859 (68); Cadinouche MAU 22552 (56); Caille, O. 14794 (50), 14992 (50); Callens, H. 3247 (8), 3409 (8); Cantley, N. 67 (47), 159 (27); Cantley's Collector 164 (27); Capuron, R. [P.R.] SF 255 (49a), SF 568 (55), 1641 (44), SF 20287 (44), SF 23220 (51), SF 23658 (53), SF 23658 bis (28), SF 23800 (46), SF 23805 (33), SF 23845 (53), SF 24022 (45), SF 24027 (44), SF 24065 bis (33), SF 24355 (45), SF 24413 (44), SF 24770 (45), SF 24978 (32), SF 28160 (68), SF 28204 (68), SF 28260 (20), SF 28266 (60), SF 28396 (46), SF 28774 (44); Carmichael, D. 12 (68); Catat, L. D. M. 2524 (33); Chalot, C. 29 (63); Chang SA 5 (27); Chapman, J. D. 3992 (50), 5247 (50); Chatelain, C. 2 (5), 538 (5); Chevalier, A. J. B. 11206 (50), 12420 (40a), 12664 (40a), 12936 (40a), 12984 (40a), 17142 (50), 17159 (40b), 17250 (5), 17542 (5), 22774 (50), 27743 (40b); Chew 735 (57); Chillou, J. 800 (50); Christiaensen 1790 (37); Christophe, R. RN 8044 (32); Church 1768 (18); Clayton 6101 (65); Clemens, J. 40466 (34); Comanor 1200 (67); Commerson, P. 371 (10); Coode, M. J. E. 4283 (56), 4765 (56), 4824 (52), 4892 (68); Cooper, G. P. 202 (13), 277* (38), 287* (13), 465 (13); Corbisier-Baland, A. 1120 (40b), 1266 (50), 1385 (40b), 1917 (40b), 1930 (50); Corner, E. J. H. SFN 32507 (62), SING 29968 (69); Coudreau, J. 84 (54), RN 50 (55); Cours, G. 1129 (53), 1203 (23), 1843 (55), 1870 (53), 1926 (16), 1943 (28), 1958 (54), 2286 (44), 2373 (55), 2405 (53), 2439 (54), 2543 (55), 2579 (53), 2772 (53), 2914 (42), 3167 (49b), 3203 (4), 3615 (32), 4177 (44), 4182 (55), 4363 (44), 4414 (55), 4425 (44), 4509 (31), 4790 (49b), 4804 (55), 4879 (43), 4893 (53); Coûteaux, G. 22 (50), 94 (50), 118 (40b); Cramer 4395 (65), 4506 (70), 4641 (70); Croat, T. B. 32246 (55), 32579 (28), 32604 (43), 32613 (54), 32647 (54).

D'Alleizette, C. 1353 (44), 1477 (55); D'Arcy, W. G. 15273 (54); D'Argent, G. MAU 21399 (56), MAU 22454 (56); Daramola, B. O. 451 (50), FHI 72488 (50); Debeaux, G. 412 (50); Decary, R. 111 (33), 1949 (32), 5200 (43), 6907 (55), 7085 (55), 10135 (49b), 10814 (58), 11018 (58), 11066 (28), 14342 (58), 14790 (49b), 15297 (55), 16786 (54), 16916 (28), 16917 (42), 16935 (54), 16952 (42), 16975 (42), 16976 (42), 16982 (4), 17694 (55), 17713 (28), 17770 (42), 17783 (55), 18428 (53); Dechamps, R. 13067 (50); De Giorgi, S. 258 (40b), 271 (50); De Graer, P. 348 (40a); Deighton, F. C. 1663 (40b); Demange, R. 3036 (50); de Néré [no initial] 1172 (50), 1355 (50); Dequaire 27657 (54), 27677 (55), 27726 (51), 27977 (23); Derleth 118 (43); Descoings, B. 180 (55), 1841 (55), 8282 (40b), 8539 (40a), 8664 (40b); Deshamel MAU 81 (56); de Silva, F. W. de 10 (70), 19 (25), 52 (70); Desvaux, A.-N. 36 (68); Dhetchuvi 964 B (40a); Dibata, J. 1097 (50); Dinklage, M. J. 2986 (13), 3056 (13); Dorr, L. 3080 (55), 3222 (42), 4484 (43); Doumenge 411 (8); Dowsett-Lemaire 1936 (50); Duah 5823 (4); Dumetz, N. 858 (28), 914 (12); Du Petit-Thouars, P. 100 (10).

Edgerley, L. F. REU 13371 (68); Ekwuno [no initial] 284 (50); Enti, A. A. GC 35586 (50), GC 42614 (50), GC 42670 (5), SP 258 (5), SP 346 (5), SP 599 (5); Evrard, C. M. 2827 (37), 2893 (37), 3901 (40a), 4932 (40b), 6083 (40b), 6223 (8), 6327 (50), 6448 (40b), 6618 (40b), 11243 (55); Exell, A. 708 (40b).

Faden, R. 76/503 (17), 77/42 (67); Fanja 539 (55); Fay, J. M. 8106 (50), 8111 (50); Fedilis SAN 94840 (34); Fleury, F. 26727 (50); Florens, D. MAU 22551 (56), MAU 22711 (56), MAU 22725 (15); Forbes 3214 (34); Forsyth-Major, C. I. 304 (49a), 317 (44), 401a (44); Fosberg, R. 56500 (59); Fotius

2690 (50); Friedmann, F. 555 (68), 933 (68), 2247 (68), 2845 (52), 2984 (52), 3023 (56), 3335 (68).

Gachet, C. SF 7531 (53); Gardner, G. 581 (70), MAU 19158 (56); Garnier, I.? 228 (68); Gautier, L. 2514 (43), 2807 (4), 2817 (53); Gautier-Beguin, D. 1032 (13), 1107 (50), 1263 (40a); Geay, [M.]F. 7370 (4), 7638 (42), 7719 (28); Geerling, C. 420 (50), 422 (5), 1689 (50); Gentry, A. H. 11575 (32); Gereau, R. E. 3236 (4); Germain, R. G. A. 2067 (50), 7551 (37), 8501 (40a); Gerrard, W. T. 37 (53), 54* (43); Gilbert, G. C. L. 14173 (50), 14813 (50); Gillet, J. 2809 (40a); Goodenough, J. S. 1630 (47), 4827a (69); Goossens, V. G. 2688* (40a), 5017 (8), 6197 (40b), 6208 (50); Gossweiler, J. 14108 (50); Gueho, J. MAU 15194 (56), MAU 17853 (52); Guillot, J. 27* (33), 36* (28), 38 (43).

Hallé, F. 4 (5), 146 (50), 217 (5), 284 (5), 296 (5), 380 (40a), 409 (4), 418 (13); Hallé, N. 2010 (18), 4437 (66), 4617 (66), 4664 (66); Hallé, W. 4664 (66); Haniff, M. SING 7947 (57), SING 21055 (48); Harder, D. K. 3751 (40b), 3753 (50); Hardial 628 (27); Harley, R. M. 1035 (40b); Harley, W. 1910 (40a); Harris, D. J. 3176 (40b); Hart, T. 319 (37); Hassan S 2200 (3), S 4928 (3); Haviland, G. D. 3460 (34); Henderson, M. R. 11476 (18), 17769 (57), SING 23390 (57); Hepper, F. N. 1514 (50), 4545 (67); Hill, H. C. 383 (27), 397 (27), 424 (27), 425 (27), 470 (27); Holttum, R. E. 53 (7), 10687 (7), SING 19944 (47); Homolle, A. M. 61 (42), 1843 (55), 1926 (16), 1958 (54), 2286 (44), 2373 (55), 2405 (53), 2543 (55); Hoogland, R. D. 11406 (67), 11451 (67); Hou 619 (48), 649 (48); Huber 582 (17), 825 (70); Hullett, R. W. 113 (47), 756 (57); Humbert, J. H. 3366 (58), 3450 (43), 3566 (16), 3578 (44), 3582 (49a), 5999 (28), 6056 (58), 6250 (49b), 6322 (49b), 17480 (49a), 17618 (53), 17829 (49a), 18201 (49a), 20600 (54), 21997 (32), 22019 (49b), 22024 (32), 22026 (55), 22045 (32), 22106 (55), 22114 (43), 22118 (49a), 22283 (53), 22429 (32), 22796 (32), 22817 (32), 23043 (55), 23106 (32), 23367 (31), 23506 (51), 24117 (49a), 24338 (43), 24378 (28), 24504 (32), 24621 (43), 28500 (49b), 31467 (53), 31669 (53), 31746 (43), 31885 (51); Humblot, [J.-H.]L. 503 (54), 504 (54), 510* (55), 655* (31); Hunter, K. L. 28 (50).

Ilias, B. P. S 39183 (18); Imbert, T. 94 (28).

Jaamal KEP 36172 (57); Jacques-Félix, H. 795 (40a), 2444 (50), 8799 (50); Jaeger, P. 1166 (40b), 1290 (50), 1665 (50), 7158 (40a), 7607 (50), 7688 (50), 7832 (50); Jansen, J. W. A. 754 (13), 1071 (13), 1119 (50), 1515 (40a), 1615 (13), 1650 (13), 2468 (13); Jaofety-Bosy [no initial; Dorr, 1997] RN 10096 (43); Jayasuriya 800 (17), 916 (70), 1509 (17), 2841 (25), 2961 (70), 2970 (70); Jeffrey, C. 231 (8); Jolly, A. 134 (63); Jongkind, C. 878 (49a), 2077 (4), 2085 (4), 4982 (13); Jumali, K. 3004 (7), 3054 (7).

Kahindo SF 116 (40b); Kalong, F. G. KEP 20457 (57); Kamarudin FRI 28767 (34); Kelsall, H. J. 1995* (17); Kenfack, D. 763 (36); Kerr, A. 15454 (64), 17764 (64), 17798 (64), 17996 (64), 19137* (34); Khairuddin, K.-D. FRI 32848 (7); Kiah, M. S. SFN 32015 (62), SING 32110 (47); Kiener, A. SF 5047 (28); Kiew 2192 (7), 2197 (18); King's Collector 8449* (48); Klaine, R. P. 52 (63), 149 (63), 202 (63), 203 (50), 393 (63), 421 (63), 516 (63), 872 (63), 1661 (63), 1769 (50); Kloss, C. B. 5963* (34); Kochummen, K. M. FRI 2311 (18), FRI 2387* (35), FRI 16671 (18), FRI 32515 (34); Kostermans, A. J. G. H. 238 (34), 1315 (34), 9252 (34), 23597 (59), 23659 A (70), 23662 B (70), 24101 (67), 24142 (65), 24210 (65), 24213 (65), 24713 (65), 25017 (70), 27020 (65), 27135 (17), 27527 (17), 27573 (65), 28274 (70); Kotozafy, A. 267 (42), 1073 (9); Kramer, [F. or W. H. de; which is unknown] 9220 (68).

Laibosaka, R. RN 10945 (31), RN 12597 (43), RN 10926 (55); Lalouette, J.-A. MAU 10010 (60); Lam, H. J. 5530 (33),

5220 (68), 5628 (54), 5628A (49b), 5720 (33); Langlassé, E. 198 (47); Larsen 58 (64); Leandri, J. D. 3204 (44); Lebrun, J. 331 (8), 739 (8), 1452 (50), 5688 (8), 5772 (8), 6271 (37), 6332 (37), 6414 (37); Lee, B. S 45386 (11); Leeuwenberg, A. J. M. 1814 (5), 2366 (5), 3798 (5), 4154* (5), 4840 (13), 5074 (8), 5350 (8), 5534 (66), 5687 (66), 5710 (50), 7106 (50), 7677 (50), 7992 (5), 8889 (50), 10352 (50), 11508 (40b), 14017 (58); Léonard, J. 84 (50), 137 (50), 2914 (37), 3743 (8); Leroy, J.-F.[P.] 8 (63); Lesmy FRI 35937 (47); Le Testu, G. 1642 (24), 7622 (40b), 8575* (24), 8642 (50), 9143 (40b), 9572 (40b); Letouzey, R. 2116 (40b), 2498 (50), 3780 (40b), 12457 (50), 12601 (40b), 12648 (66), 13702* (36), 14153 (36), 14907 (66), 15091 (50), 15223 (66); Lewis, B. 756 (58), 786 (55), 819 (58), 1030 (49a), 1253 (32), 1306 (49a), 1318 (32); Liengola 157 (37); Linder, D. H. 286 (13), 758 (40a), 1487A (13), 1487B (13); Lisowski, S. 16116 (8), 18904 (8), 45071 (8), 52450 (8), 90036 (8), 90039 (8); Lorence, D. H. 1495 (56), 1541 (56), 1548 (60), 1597 (56), 1956 (56), 2125 (56), 2201 (20), 2209 (56), 2224 (39), 2415 (68), 2674 (39), 4449 (56), 4490 (56), M 278 (15), M 281 (56); Louis, A. M. 909 (37), 1309 (50), 1344 (66), 1680 (63); Louis, J. 944 (40b), 1881 (40b), 1896 (50), 2006 (50), 2252 (37), 2305 (37), 9169 (40b), 9979* (37), 11211 (37), 11586 (37), 12577* (40b); Lourteig, A. 2459 (68); Lowe, J. 3623 (50); Lowry, P. P. 4036 (41), 4127 (12), 4155 (41), 4181 (30), 4262 (55), 4272 (42), 4283* (45), 4471 (12), 4486A (12); Lyall, R. 161 (55), 193 (55).

Macrae, J. 602 (70); Madani SAN 107944 (2); Maingay, A. C. 2701 (47), 925 (47); Malcomber, S. T. 930 (4), 999 (58), 1018* (58), 1065 (49a), 1152 (4), 1172 (58), 1275 (4), 1460 (49a), 1799 (4), 1946 (4), 2027 (34), 2028 (34), 2155 (58), 2173 (4), 2229 (4), 2585 (42), 2589 (55), 2594 (43), 2637 (4), 2676 (43), 2705 (43), 2709 (43), 2710 (32), 2733 (55), 2742 (41), 2758 (59), 2759 (59), 2760 (67), 2761 (67), 2762 (17), 2763 (67), 2764 (70), 2765 (70), 2766 (65), 2767 (65), 2768 (25), 2769 (25), 2770 (70), 2771 (70), 2772 (51), 2773* (32), 2774 (43), 2776 (49a), 2777 (43), 2778 (43), 2779 (51), 2780 (51), 2781* (51), 2782 (43), 2783 (49b), 2786 (49a), 2788 (49b), 2789 (49b), 2793 (49a), 2795 (32), 2799 (49a), 2800 (41), 2802 (19), 2803 (12), 2807 (43), 2812 (4), 2814 (54), 2815 (4), 2817 (30), 2818 (30), 2819 (49a), 2820 (12), 2821 (55), 2822 (19), 2824 (30), 2825 (61), 2827* (41), 2829 (61), 2830 (53), 2833 (53), 2834 (43), 2836 (49b), 2837 (49b), 2838 (49a), 2839 (49b), 2840 (49b), 2857 (49b), 2859 (49b), 2865 (44), 2866 (55), 2867 (9), 2869 (49a), 2870 (44), 2875 (58), 2876 (9), 2877* (9), 2878 (58), 2881 (49a), 2882 (49a), 2884 (28), 2885 (28), 2886 (33), 2887* (46), 2888 (41), 2897 (30), 2900 (33), 2901 (33), 2909 (46), 2910 (54), 2911 (43), 2912 (28), 2913 (28), 2914 (49a), 2915 (43), 2916 (49b), 2917 (49b), 2918 (49b), 2919 (49b), 2920 (43), 2921* (16), 2922 (16), 2925* (45), 2926 (49a), 2927 (55), 2928 (49b), 2929 (49b), 2930 (56), 2931 (56), 2932 (39), 2933 (52), 2934 (29), 2935 (39), 2936 (52), 2937 (29), 2938 (56), 2939 (56), 2940 (15), 2941 (20), 2942 (20), 2943 (20), 2944 (20), 2945 (20), 2946 (56), 2947 (56), 2948 (20), 2949 (60), 2950 (20), 2951 (20), 2953 (20), 2954 (20), 2955 (60), 2956 (20), 2957 (56), 2958 (56), 2959 (20), 2960 (20), 2961 (20), 2962 (20), 2963 (20), 2964 (49b), 2965 (34), 2966 (4), 2967 (34), 2968 (34), 2971 (3), 2977 (34), 2978 (34), 2979 (34), 2981 (34), 2983 (34), 2984 (34), 2985 (34), 2986 (3), 2987 (3), 2988 (3), 2989 (3), 2990 (3), 2991 (3), 2992 (3), 2993 (3), 2994 (3), 2995 (3), 2996 (3), 2997 (3), 2998 (3), 2999 (3), 3000 (3), 3001 (34), 3002 (34), 3003 (34), 3004 (34), 3005 (34), 3006 (34), 3007 (47), 3008 (27), 3009 (27), 3010 (69), 3011 (57), 3012 (57), 3013 (57), 3016 (57), 3017 (57), 3018 (18), 3019 (18), 3020 (18), 3021 (48), 3022 (48), 3023 (7), 3024* (7), 3025 (47), 3026 (62), 3031 (34), 3033 (22), 3037 (11), 3038

(26), 3039 (48), 3040 (48), 3044 (34), 3045 (34); Mann, G. 1791* (66); Manning, S. 1704 (8), 2200 (50); Manohiraza [no initial; Dorr, 1997] RN 8709 (55); Marmo, V. 18 (40a), 19 (40b); Martin, S. 38199 (34); Mat [no initial; Vegter, 1976] 3723 (7); Mat-Salleh, K. 3250 (34); Maxwell, J. F. 78-339 (27), 78-386 (27), 81-75 (27), 81-159 (27), 985 (67); McPherson, G. 14146 (28), 16334 (50), 16292 (50), 16360 (53), 16553 (43); Meijer, W. 982 (17), 11241 (34), SAN 21809 (3); Melville, F. A. 613 (50); Mengé, A. 38 (8); Merello, M. 1285 (4), 1412 (4); Messmer, N. 690 (1), 692 (1); Mildbraed, G. W. J. 3206* (37), 3287* (37); Miller, J. S. 3818 (42), 3821 (55), 3918 (55), 3978* (6), 4050 (32), 4189 (32), 4488 (53), 4667 (32), 4483 (51); Mocquerys, A. 155 (30), 167* (30), 197 (4), 221 (53), 273* (19), 349 (54); Mogeia 3457 (11); Moise [no initial] 2 (28), 5 (34), 6 (54), 9 (61), 10 (53), 11 (30); Morat, P. 2746 (68), 3215 (49a), 4150 (43), 8576 (42), 8587 (30), 8611 (42), 8613 (30); Morton, J. K. GC 8473 (13); Moureau, J. 14 (40b); Moysoy, L. SING 31022 (57); Mpom, B. 334 (40b); Muin Chai SAN 29840 (34); Murata B-668 (34); Muslim Plant Collector 19 (25).

Ndjele 731 (8), 735 (8); Ng, F. S. P. FRI 1935 (18), FRI 22056 (18), FRI 22075 (69), FRI 5233 (47), FRI 5893 (57), FRI 6081 (48); Nickille 4816 (57); Nicoll, M. F. 105 (58), 106 (58), 170 (49a), 202 (55), 464 (54), 616 (32); Nielson 1059 (34); Noor, M. 1504 (27); Nooteboom, H. P. 1526 (18), 3122 (65), 3123 (70), 3212 (17), 4324 (18); Nur, M. 7765 (69), 7807 (47), 11174 (18), 11613 (18), SING 34357 (48).

Okeke, R. FHI 38440 (50); Oldeman, R. 240 (5), 468 (50); Onochie, C. F. A. FIH 33168 (21); Othman, S. 19909 (34); Overdorff, D. 24 (55).

Page, W. 94 (52), 226 (52), 227 (52), MAU 22729 (39); Paivo Pierre RN 8866 (54); Pauwels, L. 4756 (40b), 5568 (37), 6656 (8); Peltier, J. 2457 (4); Perrier de la Bâthie, [J. M.] H. [A.] 3649 (43), 3661 (49b), 3744 (33), 3754 (33), 3806 (53), 3836 (32), 3943 (55), 4014 (55), 6892 (44), 6928 (49b), 17098* (1), 17449 (43), 18361 (55), 18527 (44), 19225 (54); Perrottet, G. 413 (50); Pierlot, R. 838 (8), 2408 (8), 2567 (40a); Pierre, [J. B.] L. 1253 (64); Pisch 7692 (50); Poilecot 3447 (5); Price 29 (34); Puff, C. 800823-1/5 (60), 800825-1/10* (29), 920503-1/1 (34); Purselove, J. W. 4190 (18), 4227 (57); Put, N. 2864 (64), 2939 (64); Pynaert, L. 119 (40b), 1788 (8).

Rabehohitra, A. R. 2159 (28), 2578 (55), 2587 (43), 4195 (28), SF 29307 (28), SF 29861 (43); Rafamantanantsoa, G. OUEM 31 (33); Rahajasoia, G. M. 1089 (61), 923 (61); Raharimalala, V. 145 (42), 193 (54), 317 (28), 1502 (19), 1502 (33), 2151 (33); Rahmat Si Boeea [or Rahmat Si Toroos, no initial; Vegter, 1983] 5418 (34), 5722 (34); Raimundo, A. R. F. 2846 (50); Rajanaparany [no initial; Dorr, 1997] RN 8162 (53); Rakoto, E. RN 1487 (49a); Rakotomalaza, P. J. 1317 (49b); Rakotoniaina RN 2426 (54), RN 2446 (54), RN 2448 (53), RN 2451 (54), RN 3218 (49b); Rakotovao RN 6841 (58), RN 8509 (58), RN 8518 (44), RN 9601 (49b), RN 9602 (53); Rakotovao, C. 108 (58); Rakotovao, G. 537 (58), 593 (49b), 607 (49b); Rakotozafy, A. 521 (33); Ralaikoto 197 (53); Ralarivohita SF 1103 (28); Ramanatsoavina, G. RN 2814 (55); Ramarokoto, M. RN 9469 (55); Randriamampionona, B. 45 (58); Randrianasolo, A. 70 (55), 288 (28), 320 (31); Ranjokiny, A. M. RN 8860 (28), RN 10845 (54); Rasoavimbahoka, F. 69 (52); Ratovoarison, F. D'A. RN 1317 (55), RN 1338 (55); Ratsirahonana, L. J. SF 15372 (58); Ravelonarivo, D. 680 (6), 903 (53); Raynal, J. 21012 (50); Razafimanantsoa, A. RN 1563 (4); Razali Salam 109 (18); Reitsma, J. 1336 (63), 2603 (66), 2645 (50), 3131 (66); Rena, R. S 60874 (34); Rena George S 40507 (34), S 58327 (11); Reygaert, F. J. 624 (37); Richard, J. M. C. 5* (33), 26 (33); Richards, P. W. 3249 (50); Richardson, I. B. K. 4046 (56),

4078 (60), 4090 B (68), 4102 (68), 4148 (68); Ridley, H. N. 13 (69), 179 (69), 1440 (47), 2679 (27), 2679a (27), 2680 (47), 3869 (69), 3892 (47), 4000 (69), 4828 (69), 4828a (69), 4828b (69), 7429* (18), 8565 (48), 8923 (69), 9500 (69), 10943 (69), 11123 (27), 12080* (18), 12528 (27), 13337 (27), 13666 (57), 16255* (18); Ridsdale, C. 1934 (70), 1935 (70), 1943 (70), 2041 (65); Roajanoparary SF2830 (42); Roberty, G. 12815 (50), 13611 (50), 15361 (13); Robinson, H. G. 5488* (57), 6275 (34); Robyns, F. H. E. A. W. 1237 (40b), 6904 (70); Runi, Y. P. C. S 59673* (11), S 62906 (34).

Sajy, C. RN 8841 (55); Saw FRI 34247 (18); Schatz, G. E. 1228 (58), 1335 (30), 1348 (54), 1542 (4), 1661 (33), 1866 (41), 1875 (31), 2425 (58), 2432 (55), 2620 (31), 2705 (12), 2808* (61), 2885 (54), 3080 (54), 3211 (49a), 3314 (30), 3346 (30), 3604 (42); Schlechter, R. 12549 (50), 12586* (40b); Schlieben, H.-J.E. 10921 (68), 8023 (43); Schnell, R. A. A. 1123 (50), 4093 (40a), 6291 (40b); Schoenmaker 117 (24); Schweinfurth, G. A. 3552* (40b); Scortechini 253* (48); Scott-Elliot, G. F. 1774 (55), 1781 (54), 2171 (55); Seigler, D. S. 12802 (43); Service Forestier de Cote Ivoire 381 (13); Shah, M. 2091 (27), 2204 (7), 2463 (27), 2789 (18), 3024 (57), 3090 (47), 3894 (27), 4208 (27); Sibat ak Luang S 21999 (11); Sieber, F. W. 52 (10), 54* (56), 55* (10), 57* (56), 188 (10), 272* (56), 332* (56), 335* (56); Silasy [i.e., Silizy, no initial; Dorr, 1997] RN 9501 (53), RN 9509 (55), RN 9512 (4); Simons, E. L. A. N. 408 (50), 547 (50); Simpson, D. A. 88/29 (53); Simpson, N. 9493 (67), 9883 (65); Sinclair, J. 4926 (27), 5125 (47), 5325 (69); Singh, J. SAN 20923 (34); Smythies, S. 5909* (3); Sohmer, S. 8677 (65), 8701 (65), 8769 (67), 8797 (67), 8930 (67), 9884 (65), 10231 (67), 10244 (67), 10288 (67), 10374 (17), 10461 (70), 10611 (70); Sonké, B. 2687 (50), 2918 (66), 2919 (40b), 2920 (66), 2921 (40b), 2923 (66), 2935 (66), 2946 (66), 3044 (50), 3106 (66), 3197 (66), 3251 (66), 3253 (66), 3293 (8), 3318 (66), 3663 (66), 3674 (66), 3934 (66), 3959 (66), 4013 (66), 4014 (66), 4179 (66), 4486 (8), 4541 (8); Soyaux, H. 24* (63), 28 (66), 178* (63); St. Clair-Thompson, G. 3586 (50); St. John, H. 26529 (68); Staub, F. MAU 11986 (56), REU 11107 (68); Stäuble 186 (13), 353 (13), 857 (13); Suhaili Hj. Zinin BRUN 15022 (34); Sumbing SAN 101357 (2); Sumithraarachichi 196 (65), 566 (70); Suppiah, T. FRI 17806 (7), FRI 17830 (7), FRI 17844 (7), KEP 98965 (69), KEP 98992 (47); Symington, C. F. 32250 (57), KEP 31454 (57), s.n. (57), SING 28865 (69).

Tachun bin Bara KEP 33613 (48); Talbot, P. A. 3005 (50), 3391* (21); Tan 8 (27); Tang 1170 (47), 1684 (34); Teijsmann, J. E. [also "Teysmann"] 10358 (27), 10732 (27), 19390 (27), 19428 (27); Theobald 2378 (17); Thollon, F.-R. 81 (40b); Thomas, D. 484 (66), 4398 (8), 6225 (40b), 6856 (8), 8117 (8), 8649 (50); Thomas, N. 1033 (40b), 2945 (50); Thwaites, G. H. K. CP 45* (65), CP 346* (25), CP 288 (70), CP 346 (25), CP 363* (25), CP 440* (65), CP 457* (65), CP 2673* (59), CP 2991* (17); Tirvengadam, D. D. 11 (68), 19 (68), 28 (20), 379/29 (56), 387/37 (56), 394/44 (20), 396/46 (56), 947 (60), 969 (15); Toutain, B. 2408 (50); Traub, Z. D. 334 (50); Troupin, G. 9165 (8), 9225 (8), 10931 (8); Turk, D. 421 (58).

Van Balgooy, M. M. J. 4052 (34), 6062 (34); van Beusekom, C. F. 839 (64), 1547 (70), 1552 (65), 1739 (64), 2666 (27); van der Maesen 5454 (63); van der Werff, H. 13526 (43); Vanderyst, H. J. R. 10337 (37); van Harten, A. M. 349 (13); van Meer, P. P. C. 110 (13), 121 (50), 1174 (21), 1185 (8); van Nek, I. 569 (24), 2107 (54); Vasey 32 (53); Vaughan, R. E. 3031 (60), MAU 1084 (52), MAU 1636 (20), MAU 1640 (20), MAU 1655 (60), MAU 3144 (15), MAU 10387 (39), MAU 11028 (52), MAU 11894 (15), MAU 12239 (20), MAU 12271 (60), MAU 12507 (20), MAU 13042 (29),

MAU 13163 (15), MAU 13751 (56), MAU 13761 (56), MAU 14123 (39), MAU 14191 (20), MAU 14222 (20); Vermeulen [J. or P., which is unknown] 794 (18); Versteegh, C. 50 (5); Vigne, C. 1948 (13); Vigreux, M. 15373 (49b); Villiers, J.-F. 247 (63); Vogel, S. 70* (50), 71* (50); Voorhoeve, A. 823 (13).

Waas, S. 52 (17), 888 (67), 1190 (67), 1316 (17), 1335 (59), 1465 (59), 1483 (70), 1511 (17), 1693 (65), 1768 (59), 1799 (59), 1840 (70), 2043 (59); Walker, F. S. KEP 33831 (7); Walker, G. W. 58* (67), 102* (70), 212 (47), 223 (70); Wallich, N. 8328* (47), 8342* (34), 8354* (69), 8374* (34), 8389* (27); Walters, G. 913 (50), 957 (50); Ward, C. 1841 (60); Waterlot, E. G. 335 (4); Watts, J. 1141 (8); White, F. 3311 (50); White, L. 1071 (50), ser. 2 335 (50); Whitmore, T. C. FRI 8726 (7), FRI 15457 (57), FRI 15503 (57), FRI 15584 (57), FRI 15585 (57); Wiehe, P. O. 1712 (68), 2746

(68); Wieringa, J. 1654 (24), 4040 (50); Wilde, J. de 135 (5), 572 (50), 637 (50), 3161 (5), 3618 (13), 8165 (40b), 8827 (66), 11449 (40b); Wilde, W. de 26 (5), 348 (5), 2917 (66), 3945 (50); Wilks, W. 72 (40b), 528 (40b); Wong, Y. K. 1088 (18), 1724 (34), FRI 28905 (48), FRI 28919 (48), FRI 28950 (48), FRI 30928 (18), FRI 32246 (18), FRI 32350 (57), FRI 32356 (18); Worthington, T. B. 1962 (70), 2287 (59), 3635 (59), 7183 (67); Wray, L. Jr. 25 (48), 1948* (48), 2283* (48), 4122 (57), 5343* (18).

Yii S 64422 (47).

Zamanivato [no initial; Dorr, 1997] RN 8252 (32), RN 8253 (55); Zenker, G. 1392 (40b), 1763* (66), 1838 (66), 2034 (66), 2252* (8), 2252a (8), 2393 (66), 3569 (66), 4207 (66), 4419 (8), 4547 (66), 4760 (66); Zjhra, M. 133 (54), 392 (41); Zollinger, H. 3051* (34).

Appendix 2. Index to names treated in this revision. Names in boldface are accepted for species of *Gaertnera* Lam.

Name	Taxonomic identity
<i>Andersonia vaginata</i> Willd. ex Roem. & Schult.	– <i>Gaertnera vaginata</i>
<i>Chassalia clusiifolia</i> var. β [beta] DC., nom. ined.	– <i>G. rotundifolia</i>
<i>C. coffeoides</i> DC.	– <i>G. psychotrioides</i>
<i>C. psychotrioides</i> DC.	– <i>G. psychotrioides</i>
<i>Coffea chasalioides</i> D. Dietr., nom. superfl. illeg.	– <i>G. psychotrioides</i>
<i>Frutesca mauritiana</i> DC. ex Meisn.	identity unclear
<i>Gaertnera acuminata</i> Benth.	– <i>G. junghuhniana</i>
<i>G. acuminata</i> var. <i>montana</i> Ridl.	– <i>G. ramosa</i>
<i>G. acuminata</i> var. <i>oxyphylla</i> (Benth.) Ridl.	– <i>G. junghuhniana</i>
<i>G. aetheonoma</i> Steud., nom. nud.	– <i>G. calycina</i>
<i>G. alata</i> Bremek. ex Malcomber & A. P. Davis	
<i>G. alstonii</i> Malcomber	
<i>G. aphanodioica</i> Malcomber	
<i>G. arenaria</i> Baker	
<i>G. aurea</i> Malcomber	
<i>G. australiana</i> C. T. White	– <i>Psychotria</i> L. sp.
<i>G. bambusifolia</i> Malcomber & A. P. Davis	
<i>G. belumutensis</i> Malcomber	
<i>G. bieleri</i> (De Wild.) E. M. A. Petit	
<i>G. bifida</i> Bojer	– <i>G. psychotrioides</i>
<i>G. boivinii</i> Drake	identity unclear
<i>G. borneensis</i> Valetton	identity unclear
<i>G. bracteata</i> E. M. A. Petit	– <i>G. longivaginalis</i> var. <i>bracteata</i>
<i>G. bracteata</i> var. <i>glabrifolia</i> E. M. A. Petit	– <i>G. longivaginalis</i> var. <i>bracteata</i>
<i>G. brevipedicellata</i> Malcomber & A. P. Davis	
<i>G. brevistylis</i> Ridl.	– <i>G. junghuhniana</i>
<i>G. caerulea</i> Bojer	– <i>Chassalia grandifolia</i> DC.
<i>G. calycina</i> Bojer	
<i>G. calycina</i> var. <i>variegata</i> Bojer	– <i>G. calycina</i>
<i>G. capitata</i> Bojer	– <i>C. capitata</i> DC.
<i>G. capitulata</i> Malcomber	
<i>G. cardiocarpa</i> Boivin ex Baill.	
<i>G. caudata</i> Ridl.	– <i>G. ramosa</i>
<i>G. chapelieri</i> Drake	identity unclear
<i>G. coerulea</i> , orth. var.	– <i>C. grandifolia</i>
<i>G. cooperi</i> Hutch. & M. B. Moss	
<i>G. crassiflora</i> Bojer	
<i>G. crassifolia</i> , orth. var.	– <i>G. crassiflora</i>
<i>G. crinita</i> Drake	= <i>G. phanerophlebia</i>

Appendix 2. Continued.

Name	Taxonomic identity
<i>G. cuneifolia</i> Bojer	
<i>G. cymiflora</i> Bojer	– <i>C. boryana</i> DC.
<i>G. darcyana</i> Malcomber & A. P. Davis	
<i>G. dinklagei</i> K. Schum.	– <i>G. trachystyla</i>
<i>G. divaricata</i> (Thwaites) Thwaites	
<i>G. diversifolia</i> Ridl.	
<i>G. drakeana</i> Aug. DC.	
<i>G. edentata</i> Bojer	
<i>G. eketensis</i> Wernham	
<i>G. ferruginea</i> A. Chev.	– <i>Premna quadrifolia</i> Schumach. & Thonn. (Verbenaceae)
<i>G. fissistipula</i> (K. Schum. & K. Krause) E. M. A. Petit	– <i>G. bieleri</i>
<i>G. fractiflexa</i> Beusekom	
<i>G. furcellata</i> (Baill. ex Vatke) Malcomber & A. P. Davis	
<i>G. gabonensis</i> Malcomber	
<i>G. ×gardneri</i> Thwaites	
<i>G. globigera</i> Beusekom	
<i>G. godefroyana</i> Cordem.	– <i>G. vaginata</i>
<i>G. grisea</i> Hook. f. ex C. B. Clarke	
<i>G. guillotii</i> (Hochr.) Bremek., hom. illeg.	– <i>G. inflexa</i>
<i>G. guillotii</i> Hochr.	
<i>G. hirtiflora</i> Verdc.	
<i>G. hispida</i> Aug. DC.	
<i>G. hongkongensis</i> Seem.	– <i>I. chinensis</i> Lam.
<i>G. humblotii</i> Drake	
<i>G. ianthina</i> Malcomber	
<i>G. incarnata</i> Bojer	– <i>C. lanceolata</i> (Poir.) A. Chev. subsp. <i>lanceolata</i>
<i>G. indica</i> J. F. Gmel.	– <i>Hiptage madablota</i> Gaertn. (Malpighiaceae)
<i>G. inflexa</i> Baill.	
<i>G. intermedia</i> Ridl.	– <i>G. diversifolia</i>
<i>G. junghuhniana</i> Miq.	
<i>G. kochummenii</i> Malcomber	
<i>G. koenigii</i> (Arn.) Wight, nom. illeg.	– <i>G. vaginans</i>
<i>G. koenigii</i> var. <i>divaricata</i> (Thwaites) C. B. Clarke	= <i>G. divaricata</i>
<i>G. koenigii</i> var. <i>oxyphylla</i> (Benth.) C. B. Clarke, nom. illeg.	= <i>G. junghuhniana</i>
<i>G. koenigii</i> var. <i>thyrsiflora</i> (Arn.) Thwaites, nom. illeg.	= <i>G. vaginans</i>
<i>G. lacerata</i> ined.	– <i>G. furcellata</i>
<i>G. lanceolata</i> Bouton ex A. DC.	– <i>G. pendula</i>
<i>G. lanceolata</i> Ridl., hom. illeg.	– <i>G. diversifolia</i>
<i>G. lasianthoides</i> C. E. C. Fisch.	– <i>Psychotria rhinocerotis</i> Blume
<i>G. latifolia</i> Ridl.	– <i>G. diversifolia</i>
<i>G. laxiflora</i> Cordem.	– <i>G. vaginata</i>
<i>G. letouzeyi</i> Malcomber	
<i>G. leucothyrsa</i> (K. Krause) E. M. A. Petit	
<i>G. liberiensis</i> E. M. A. Petit	
<i>G. longevaginalis</i> , orth. var.	– <i>G. longivaginalis</i>
<i>G. longiflora</i> C. F. Gaertn.	identity unclear
<i>G. longifolia</i> Bojer	
<i>G. longifolia</i> var. <i>pubescens</i> Verdc.	– <i>G. longifolia</i>
<i>G. longipetiolata</i> R. D. Good	– <i>Psychotria gossweileri</i> E. M. A. Petit
<i>G. longivaginalis</i> (Schweinf. ex Hiern) E. M. A. Petit	
<i>G. longivaginalis</i> var. <i>bracteata</i> (E. M. A. Petit) Malcomber	
<i>G. longivaginalis</i> (Schweinf. ex Hiern) E. M. A. Petit var. <i>longivaginalis</i>	
<i>G. longivaginalis</i> var. <i>louisii</i> E. M. A. Petit	– <i>G. longivaginalis</i> var. <i>longivaginalis</i>
<i>G. lowryi</i> Malcomber	
<i>G. lushaiensis</i> C. E. C. Fisch.	– <i>C. lushaiensis</i> (C. E. C. Fisch.) C. E. C. Fisch.

Appendix 2. Continued.

Name	Taxonomic identity
<i>G. macrobotrys</i> Baker	
<i>G. macrostipula</i> Baker	
<i>G. madagascariensis</i> (Hook. f.) Malcomber & A. P. Davis	
<i>G. microphylla</i> Capuron ex Malcomber & A. P. Davis	
<i>G. monstrosa</i> Malcomber	
<i>G. morindoides</i> Baker	– <i>Morinda morindoides</i> (Baker) Milne-Redh.
<i>G. obesa</i> Hook. f. ex C. B. Clarke	
<i>G. oblanceolata</i> King & Gamble	
<i>G. oblanceolata</i> Ridl., hom. illeg.	= <i>G. diversifolia</i>
<i>G. oblanceolata</i> var. <i>diversifolia</i> (Ridl.) Beusekom	= <i>G. diversifolia</i>
<i>G. obovata</i> Baker	
<i>G. obovata</i> Baker var. <i>obovata</i>	
<i>G. obovata</i> var. <i>sphaerocarpa</i> (Baker) Malcomber	
<i>G. obtusifolia</i> (DC.) Roxb.	– <i>H. obtusifolia</i> (Roxb.) DC. (Malpighiaceae)
<i>G. occidentalis</i> Baill.	– <i>G. paniculata</i>
<i>G. ovata</i> Ridl.	– <i>G. diversifolia</i>
<i>G. oxycarpa</i> Drake	identity unclear
<i>G. oxyphylla</i> Benth.	– <i>G. junghuhniana</i>
<i>G. oxyphylla</i> Drake, hom. illeg.	– <i>G. pendula</i>
<i>G. oxyphylla</i> var. <i>angustifolia</i> Ridl.	– <i>G. junghuhniana</i>
<i>G. pangati</i> Rheede ex Retz.	– <i>Sphenoclea zeylanica</i> Gaertn. (Lobeliaceae/Campanulaceae)
<i>G. paniculata</i> Benth.	
<i>G. parviflora</i> Bojer	– <i>G. psychotrioides</i>
<i>G. parvipaniculata</i> E. M. A. Petit	– <i>G. leucothyrsa</i>
<i>G. pauciflora</i> Malcomber & A. P. Davis	
<i>G. pedicellata</i> Ridl.	– <i>G. ramosa</i>
<i>G. pendula</i> Bojer	
<i>G. petrinensis</i> Verdc.	– <i>G. edentata</i>
<i>G. phanerophlebia</i> Baker	
<i>G. phyllosepala</i> Baker	
<i>G. phyllostachya</i> Baker	
<i>G. plagiocalyx</i> K. Schum.	– <i>G. longivaginalis</i> var. <i>longivaginalis</i>
<i>G. pongatii</i> , orth. var.	= <i>Sphenoclea zeylanica</i> Gaertn. (Lobeliaceae/Campanulaceae)
<i>G. psychotrioides</i> (DC.) Baker	
<i>G. quadriseta</i> A. DC.	= <i>G. psychotrioides</i>
<i>G. quadriseta</i> var. <i>brevipes</i> A. DC.	– <i>G. psychotrioides</i>
<i>G. quadriseta</i> var. <i>hebeoda</i> A. DC.	– <i>G. psychotrioides</i>
<i>G. quadriseta</i> var. <i>petiolaris</i> A. DC.	– <i>G. psychotrioides</i>
<i>G. quadriseta</i> var. <i>platypoda</i> A. DC.	– <i>G. psychotrioides</i>
<i>G. racemosa</i> (Cav.) Roxb.	– <i>H. benghalensis</i> (L.) Kurz (Malpighiaceae)
<i>G. ramosa</i> Ridl.	
<i>G. raphaelii</i> Malcomber	
<i>G. rhodantha</i> Baker	– <i>G. spicata</i>
<i>G. richardii</i> Drake	– <i>Psychotria</i> sp.
<i>G. rigida</i> Ridl.	– <i>G. diversifolia</i>
<i>G. rosea</i> Thwaites ex Benth.	
<i>G. rotundifolia</i> Bojer	
<i>G. rufinervis</i> Stapf	– <i>Psychotria</i> L. sp.
<i>G. salicifolia</i> C. H. Wright ex Baker	– <i>G. trachystyla</i>
<i>G. salicifolia</i> Hutch. & Gillett, hom. illeg.	– <i>G. liberiensis</i>
<i>G. schatzii</i> Malcomber	
<i>G. schizocalyx</i> Bremek.	
<i>G. sessiliflora</i> Ridl.	– <i>G. ramosa</i>
<i>G. sieberi</i> C. Presl	– <i>G. calycina</i>
<i>Gaertnera</i> sp. A Verdc.	probably – <i>G. calycina</i>
<i>G. spathacea</i> Boivin ex Drake	– <i>G. arenaria</i>

Appendix 2. Continued.

Name	Taxonomic identity
<i>G. sphaerocarpa</i> Baker	– <i>G. obovata</i> var. <i>sphaerocarpa</i>
<i>G. spicata</i> K. Schum.	
<i>G. sralensis</i> (Pierre ex Pit.) Kerr	
<i>G. stictophylla</i> (Hiern) E. M. A. Petit	identity unclear
<i>G. taiensis</i> Kerr	– <i>G. junghuhniana</i>
<i>G. ternifolia</i> Thwaites	
<i>G. thyrsiflora</i> (Arn.) Blume	– <i>G. vaginans</i>
<i>G. trachystyla</i> (Hiern) E. M. A. Petit	
<i>G. thouarsii</i> Baill.	identity unclear
<i>G. truncata</i> A. DC.	– <i>G. psychotrioides</i>
<i>G. vaginans</i> (DC.) Merr.	
<i>G. vaginans</i> subsp. <i>junghuhniana</i> (Miq.) Beusekom	– <i>G. junghuhniana</i>
<i>G. vaginans</i> subsp. <i>junghuhniana</i> f. <i>hermaphroditica</i> Beusekom	– <i>G. aphanodioica</i>
<i>G. vaginata</i> Lam.	
<i>G. viminea</i> Hook. f. ex C. B. Clarke	
<i>G. violascens</i> Ridl.	– <i>Psychotria</i> sp.
<i>G. walkeri</i> (Arn.) Blume	
<i>G. walkeri</i> var. <i>angustifolia</i> Benth.	– <i>G. ternifolia</i>
<i>G. walkeri</i> var. <i>gardneri</i> (Thwaites) C. B. Clarke	– <i>G. ×gardneri</i>
<i>G. zimmermannii</i> K. Krause & Gilg	– <i>Strychnos</i> L. sp. (Loganiaceae)
<i>G. zollingeriana</i> Miq.	= <i>G. junghuhniana</i>
<i>Grumilea fissistipula</i> K. Schum. & K. Krause	= <i>G. bieleri</i>
<i>Hymenocnemis madagascariensis</i> Hook. f.	– <i>G. madagascariensis</i>
<i>Mussaenda borbonica</i> Lapeyrère	– <i>G. vaginata</i>
<i>Ophioxylon arboreum</i> Koenig ex DC., nom. nud., pro syn.	– <i>G. vaginans</i>
<i>Pristidia divaricata</i> Thwaites	– <i>G. divaricata</i>
<i>Psychotria bieleri</i> De Wild.	– <i>G. bieleri</i>
<i>P. furcellata</i> Baill. ex Vatke	– <i>G. furcellata</i>
<i>P. guillotii</i> Hochr.	– <i>G. inflexa</i>
<i>P. leucothyrsa</i> K. Krause	– <i>G. leucothyrsa</i>
<i>P. longivaginalis</i> Schweinf. ex Hiern	– <i>G. longivaginalis</i>
<i>P. obesa</i> Wall., nom. nud.	– <i>G. obesa</i>
<i>P. oxyphylla</i> Wall., nom. nud.	= <i>G. junghuhniana</i>
<i>P. sralensis</i> Pierre ex Pit.	= <i>G. sralensis</i>
<i>P. stictophylla</i> Hiern	– <i>G. stictophylla</i>
<i>P. trachystyla</i> Hiern	– <i>G. trachystyla</i>
<i>P. vaginans</i> DC.	– <i>G. vaginans</i>
<i>P. viminea</i> Wall., nom. nud.	– <i>G. viminea</i>
<i>Sykesia acuminata</i> (Benth.) Kuntze	– <i>G. junghuhniana</i>
<i>S. arenaria</i> (Baker) Kuntze	– <i>G. arenaria</i>
<i>S. calycina</i> (Bojer) Kuntze	– <i>G. calycina</i>
<i>S. crassiflora</i> (Bojer) Kuntze	– <i>G. crassiflora</i>
<i>S. cuneifolia</i> (Bojer) Kuntze	– <i>G. cuneifolia</i>
<i>S. edentata</i> (Bojer) Kuntze	– <i>G. edentata</i>
<i>S. grisea</i> (C. B. Clarke) Kuntze	= <i>G. grisea</i>
<i>S. hongkongensis</i> (Seem.) Kuntze	= <i>I. chinensis</i> Lam.
<i>S. junghuhniana</i> (Miq.) Kuntze	– <i>G. junghuhniana</i>
<i>S. koenigii</i> Arn., nom. superfl. illeg.	– <i>G. vaginans</i>
<i>S. lanceolata</i> Kuntze, nom. nud.	identity unclear
<i>S. longifolia</i> (Bojer) Kuntze	– <i>G. longifolia</i>
<i>S. macrobotrys</i> (Baker) Kuntze	– <i>G. macrobotrys</i>
<i>S. macrostipula</i> (Baker) Kuntze	– <i>G. macrostipula</i>
<i>S. obovata</i> (Baker) Kuntze	– <i>G. obovata</i> var. <i>obovata</i>
<i>S. oxyphylla</i> (Benth.) Kuntze	– <i>G. junghuhniana</i>
<i>S. paniculata</i> (Benth.) Kuntze	– <i>G. paniculata</i>

Appendix 2. Continued.

Name	Taxonomic identity
<i>S. pendula</i> (Bojer) Kuntze	– <i>G. pendula</i>
<i>S. phanerophlebia</i> (Baker) Kuntze	– <i>G. phanerophlebia</i>
<i>S. phyllosepala</i> (Baker) Kuntze	– <i>G. phyllosepala</i>
<i>S. phyllostachya</i> (Baker) Kuntze	– <i>G. phyllostachya</i>
<i>S. psychotrioides</i> (DC.) Kuntze	– <i>G. psychotrioides</i>
<i>S. rosea</i> (Thwaites ex Benth.) Kuntze	– <i>G. rosea</i>
<i>S. rotundifolia</i> (Bojer) Kuntze	– <i>G. rotundifolia</i>
<i>S. sphaerocarpa</i> (Baker) Kuntze	– <i>G. obovata</i> var. <i>sphaerocarpa</i>
<i>S. ternifolia</i> (Thwaites) Kuntze	= <i>G. ternifolia</i>
<i>S. thyrsoflora</i> Arn.	= <i>G. vaginans</i>
<i>S. vaginans</i> (DC.) Kuntze	– <i>G. vaginans</i>
<i>S. vaginata</i> (Lam.) Kuntze	– <i>G. vaginata</i>
<i>S. viminea</i> (Hook. f. ex C. B. Clarke) Kuntze	– <i>G. viminea</i>
<i>S. walkeri</i> Arn.	– <i>G. walkeri</i>
<i>S. zollingeriana</i> (Miq.) Kuntze	– <i>G. junghuhniana</i>
<i>Tsiangia hongkongensis</i> (Seem.) P. P. H. But, H. H. Hsue & P. T. Li	– <i>I. chinensis</i> Lam.
<i>Uragoga sralensis</i> Pierre ex Pit.	– <i>G. sralensis</i>
<i>U. stipulacea</i> Kuntze	– <i>G. obesa</i>

CRYPTIC DIOECY IN *NYSSA*
YUNNANENSIS (NYSSACEAE), A
CRITICALLY ENDANGERED
SPECIES FROM TROPICAL
EASTERN ASIA¹

Bao-Ling Sun,^{2,3} Chang-Qin Zhang,²
Porter P. Lowry II,^{4,5} and Jun Wen⁶

ABSTRACT

Nyssa yunnanensis W. Q. Yin ex H. N. Qin & Phengklai (Nyssaceae) is a critically endangered range-restricted tree species known from only three small populations in a tropical forest area of southern Yunnan Province, southwestern China. Two types of individuals occur, one bearing staminate flowers and the other with morphologically perfect flowers that produce both pollen and fruit, suggesting an androdioecious breeding system. Field and laboratory studies conducted between 2004 and 2007 indicate, however, that *N. yunnanensis* is functionally dioecious: pollen from the morphologically perfect flowers is inaperturate and inviable, rendering the trees that bear these flowers functionally female. Field observations showed that the staminate flowers opened 10 to 15 days earlier than the protogynous female flowers but that flowering ceased at nearly the same time in both sexes. Thirty-six species of insects were observed and collected visiting the flowers of *N. yunnanensis*, four of which served as effective pollinators. Breeding system experiments demonstrated that the predominantly entomophilous pollination system is supplemented by anemophily and further indicated that *N. yunnanensis* is xenogamous and does not appear to exhibit parthenogenesis. The average sex ratio of individuals within the three populations was female-biased (0.57:1), but the ratio among flowers was male-biased (2.56:1) because flower production was higher in males. The 37 known trees of *N. yunnanensis* are likely the remnants of a once more widespread, abundant species that has been heavily impacted by human disturbance, a fate shared with many other threatened Southeast Asian taxa whose continued survival will require dedicated conservation efforts informed by a detailed understanding of population structure and reproductive biology.

Key words: Androdioecy, critically endangered, cryptic dioecy, floral phenology, IUCN Red List, *Nyssa*, *Nyssa yunnanensis*, Nyssaceae, pollen viability.

The existence of dioecism in flowering plants has been universally acknowledged since Darwin (1877), yet dioecy is still poorly understood from both an ecologic and evolutionary point of view (Bawa & Opler, 1975). The reason for this may be the relatively low proportion of dioecious taxa (Yamplosky & Yamplosky, 1922), although Ashton (1969) and Bawa and Opler (1975) reported a large number of dioecious tree species in tropical forest and dioecy appears to be favored in island environments (Baker & Cox, 1984; Sakai & Weller, 1999; Carpenter et al., 2003). So far, however, relatively few evolutionary studies have been

conducted on tropical forest trees from eastern Asia (e.g., Ashton, 1969, 1977).

The use of a functional perspective to study plant sexual systems has greatly advanced our understanding of sexual strategies in these organisms and has paved the way for testing relevant evolutionary hypotheses on the phenotypic distribution of sex allocations in populations (Lloyd, 1980; Mayer & Charlesworth, 1991; Sakai & Weller, 1999; Delph & Wolf, 2004; Dunthorn, 2004; Pannell, 2005). Dioecious species may vary in their sexual expression resulting in androdioecy, gynodioecy, trioecy, or

¹ We are grateful to J. R. Pannell, S. A. Cunningham, S. Q. Huang, and J. W. Zhang for helpful comments on earlier versions of this manuscript, X. K. Fan for help in the scanning electron microscopy, L. Z. Wang for identifying the insect specimens, F. L. Zhou for providing assistance and permission to work in the study populations, and F. Q. Shi and W. Tian for their support during our fieldwork. This study was funded by the National Natural Science Foundation of China (30770139, 30571137) and Natural Science Foundation of Yunnan, China (2005 C0051M).

² Kunming Institute of Botany, Chinese Academy of Sciences, 132 Lanhei Road, Kunming, Yunnan 650204, People's Republic of China. The first and second authors contributed equally to the work reported here. Author for correspondence: zhangchangqin@mail.kib.ac.cn.

³ Graduate School, Chinese Academy of Sciences, Beijing 100049, People's Republic of China.

⁴ Missouri Botanical Garden, P.O. Box 299, St. Louis, Missouri 63166-0299, U.S.A.

⁵ Département Systématique et Evolution, Muséum National d'Histoire Naturelle, C.P. 39, 57 rue Cuvier, 75231 Paris CEDEX 05, France.

⁶ Department of Botany, National Museum of Natural History, MRC166, Smithsonian Institution, Washington, D.C. 20013-7012, U.S.A. wenj@si.edu.

doi: 10.3417/2008015

subdioecy (Sakai & Weller, 1999). Mayer and Charlesworth (1991) defined cryptic or functional dioecy as a breeding system that has unisexual morphs, at least one of which appears to have perfect, hermaphrodite flowers. Flowers of such morphs in cryptically dioecious taxa retain nonfunctional organs, either as a gynoecium in functionally staminate flowers or an androecium in functionally pistillate ones. The sex ratio of functionally dioecious species is expected to be 1:1 in populations (Lloyd & Webb, 1977), although a biased sex ratio is in fact often observed (e.g., Melampy & Howe, 1977; Mayer & Charlesworth, 1991; María & Ramón, 1995; Queenborough et al., 2007).

Nyssa L. (Nyssaceae) comprises about 13 species, with four in North America, one in Costa Rica, one ranging from India to Indonesia, and seven in China (including six endemic species) (Qin & Phengklai, 2007). The genus exhibits a disjunct distribution between eastern Asia and North America (Eyde, 1966, 1988; Wu & Fan, 1977; Fang et al., 1983; Wen & Stuessy, 1993; Wu et al., 2003) and has a rich fossil record in the Tertiary of the Northern Hemisphere (Eyde, 1963). The reproductive system of *Nyssa* has often been described to be polygamodioecious (e.g., Wangerin, 1910; Eyde, 1963; Wu & Fan, 1977; Wen & Stuessy, 1993; Qin & Phengklai, 2007), although it has not been documented clearly for most species. Wangerin (1910) presumed that *Nyssa* species were pollinated by wind and insects. Cipollini and Stiles (1991) and Batra (1999) studied the cost of reproduction and the behavior of native flower-visiting bees in the North American species *N. sylvatica* Marshall. Both studies indicated that *N. sylvatica* is dioecious and documented native bees as its pollinators. *Nyssa aquatica* L., another North American species, is also dioecious and may be pollinated by both insects and wind (Shea et al., 1993), but the pollination biology and breeding systems of Asian members of the genus are still poorly known.

Nyssa yunnanensis W. Q. Yin ex H. N. Qin & Phengklai was originally (and invalidly) described by Wu and Fan (1977) based on two collections, one bearing only staminate flowers and the other in fruit. Wen and Stuessy (1993) reconstructed the phylogeny of *Nyssa* using 18 morphological characters and regarded *N. yunnanensis* and *N. javanica* (Blume) Wangerin as closely related taxa with the two species possessing capitate male inflorescences. Because the morphology of *N. yunnanensis* was poorly documented, Wen and Stuessy (1993) treated it as belonging to the *N. javanica* complex and used *N. javanica* to represent this presumed lineage in their phylogenetic analysis in an attempt to reduce the impact of missing data. Based on comparisons of herbarium specimens

and field observations, we found that *N. yunnanensis* differs from *N. javanica* in bearing thicker leathery leaves, but both appeared to be morphologically androdioecious, with structurally male and hermaphroditic flowers borne on different individuals coexisting in the same population (Sun & Zhang, 2007). Androdioecy is a rare breeding system in angiosperms (Darwin, 1877; Lloyd, 1975; Charlesworth & Charlesworth, 1978; Bawa & Beach, 1981; Ross, 1982; Charlesworth, 1984; Liston et al., 1990; Fritsch & Rieseberg, 1992; Pannell, 2002), and many reported instances have proven to be functionally dioecious when examined in detail, with the morphologically perfect flowers in fact being functionally female (e.g., Charlesworth, 1984; Anderson & Symon, 1989; Schlessman et al., 1990; Mayer & Charlesworth, 1991).

Nyssa yunnanensis is a canopy tree species whose range is located at the northern edge of the East Asian tropical zone. It is confined to mountainous bogs and marshes in southern Yunnan Province, China (Fu, 1989), and is seriously threatened (Fu, 1992), having been listed as Critically Endangered (CR) in 2004 based on the IUCN Red List criteria (IUCN, 2008) and proposed for transfer from Rank III to Rank I protection in China (Wang & Xie, 2004). Understanding the reproductive biology of highly threatened species such as *N. yunnanensis* is important for developing conservation strategies, especially when they are known only from very few populations (see Falk & Holsinger, 1991; Bernardello et al., 1999).

In this study, we documented the floral phenology, pollen morphology and germination, sex ratio, pollination biology, and mating system of *Nyssa yunnanensis* to address the following questions: (1) Is *N. yunnanensis* functionally dioecious? (2) If so, what is its sex ratio? (3) Is it pollinated by wind, insects, or both? (4) Can any relationships be detected among the breeding system, sex ratio, and the rarity of *N. yunnanensis*?

MATERIAL AND METHODS

STUDY SPECIES

Nyssa yunnanensis is a critically endangered wetland tree up to 30 m in height. It has small green-yellow sessile flowers (ca. 2 mm long) arranged in capitulae less than 5 mm wide (Sun & Zhang, 2007). Its flowers, which are of two types, structurally male and perfect, secrete abundant nectar with an applelike fragrance from the surface of the ovary disc. The single-seeded drupes have a low germination rate, and no seedlings have been observed in natural populations (Sun et al., 2007). *Nyssa yunnanensis*

often grows in association with species of *Quercus* L., *Juglans* L., *Persea* Mill., and *Laurus* L., particularly in riparian vegetation along rivers (Fang et al., 1983).

STUDY SITE

Nyssa yunnanensis is known from only three populations at Puwen Tropical Forest Station (101°06'E, 22°25'N) in southern Yunnan, one along a stream at 842 m (hereafter referred to as the Stream population), one around a well at 837 m (the Well population), and the third at ca. 900 m adjacent to an old dam (the Dam population). The size of these three populations is small, with 14, 9, and 14 individuals, respectively. Field investigations were conducted from 2004 to 2007. Experiments were carried out continuously on two trees bearing staminate flowers and three trees with morphologically perfect flowers (all others were so tall, reaching to almost 30 m in height, as to make it difficult or impossible to access flowers on a regular basis). In order to assess sex ratios, we did, however, have local people climb all trees in each of the three populations to collect specimens.

FLORAL PHENOLOGY

Floral phenology was studied in the wild populations of *Nyssa yunnanensis* in 2006. Two tagged male trees were monitored to record information of phenological phases, such as morphological changes, flowering period, flower life span, anther dehiscence, nectar production, odor, and fruiting. Data were recorded from a total of 40 fertile branches bearing 197 inflorescences and a total of 2811 flowers. The same types of information were collected from three trees bearing morphologically perfect flowers with a total of 40 branches bearing 82 inflorescences and 590 flowers. Flower longevity was assessed by daily observation of 30 flowers randomly sampled and tagged before anthesis. Information on other stages of flowering and fruiting was obtained by weekly observations.

POLLEN VIABILITY AND STIGMATIC RECEPTIVITY

Pollen from both male and morphologically perfect flowers was examined with a light microscope (10×) and a scanning electron microscope (KYKY-1000B; Science Apparatus Co. of the Chinese Academy of Sciences, Beijing, China). Pollen viability was estimated in vitro by recording pollen germination in a gradient series of sucrose solutions (0.5%, 1%, 2%, 5%, and 10%) with distilled water as the control (Hu, 1993). Mature anthers were identified by color

change, 10 of which were collected from male and from morphologically perfect flowers, respectively, and examined under the light microscope once per hour, with each experiment repeated five times. The inflorescences were collected, taken to the lab, and placed in a culture dish containing water to test pollen longevity. Observations were made every three hours. The data were analyzed using the software package SPSS 11.0 (SPSS Inc., Chicago, Illinois, U.S.A.). Stigmatic receptivity was checked by examining changes in style color and shape, and then verified by diaminobenzidine (DAB) (Dafni, 1992).

SEX RATIO WITHIN POPULATION AND AMONG FLOWERS

The within-population sex ratio of individual trees was determined for all 37 individuals at the three known sites based on observations made over the three years from 2005 to 2007. For each tree, a visual inspection of 30 to 100 flowers from approximately five inflorescences allowed us to determine its sexual status.

In order to determine whether *Nyssa yunnanensis* is functionally dioecious, consideration had to be given to the relative number of staminate and morphologically perfect flowers (the latter potentially being functionally female) in the populations (see Opler & Bawa, 1978; Webb & Lloyd, 1980). We therefore estimated the total within-population ratio of structurally staminate to perfect flowers (hereafter referred to as the population flower ratio [PFR]) according to a modified version of the method proposed by Opler and Bawa (1978). The PFR was calculated by multiplying the ratios of morphologically staminate and perfect flowers per inflorescence (the flowers per inflorescence ratio [FR]) by the ratios of inflorescences bearing structurally staminate and perfect flowers per branch (the inflorescence ratio [IR]), and then multiplying this in turn by the ratios of structurally staminate and perfect branches per tree (the branch ratio [BR]) and by the population sex ratios (PR). The resultant product, which can be expressed by the following formula, $PFR = FR \times IR \times BR \times PR$, provides an estimate of the ratio of total number of staminate to total morphologically perfect flowers in the three known populations of *N. yunnanensis*. For our estimate of the ratio of flowers per inflorescence, we examined all 37 individuals in the three populations and randomly selected 50 staminate inflorescences and 50 morphologically perfect ones to assess the FR, 40 branches from trees with staminate flowers and 40 branches from individuals with morphologically perfect flowers to determine the IR, and finally five trees with staminate flowers and five with morphologically perfect flowers to calculate

the BR. Sex ratios are consistently presented as male:female, with the second term always given as unity (1) such that ratios in which the first term is less than one indicate a female-biased sex ratio and those with the first term greater than one indicate a male-biased ratio.

FLORAL VISITORS

Floral visitors were recorded in the field at flowering time between 07:00 and 23:00 during 11 days between 15 and 25 March 2006, for a total of 176 hours of observation. Pollinator behavior and movement between the male and the morphologically perfect flowers were documented by photographs. Insect visitors were captured and brought to the laboratory of the Puwen Tropical Forest Station for identification and for further examination under the light microscope to detect any presence of pollen. Voucher insect specimens were deposited at the Kunming Institute of Botany.

MATING SYSTEM

To test whether individuals with morphologically perfect flowers produced viable pollen and were capable of both female and male function, an experimental protocol was used during the 2006 and 2007 flowering seasons involving a control and seven treatments, as follows: flowers were (1) untreated to serve as the control; (2) bagged to assess whether anthers on morphologically perfect flowers are capable of self-pollination in the absence of pollinators; (3) emasculated and bagged to investigate possible parthenogenesis; (4) emasculated and artificially self-pollinated to test for intra-flower self-compatibility; (5) emasculated and artificially pollinated with pollen from another morphologically perfect flower from the same individual to test for inter-flower self-compatibility; (6) emasculated and artificially cross-pollinated with pollen from a male flower to test xenogamy and to assess whether gene flow is possible between the plants with staminate flowers and those with morphologically perfect flowers; (7) emasculated and netted to test wind pollination; and (8) directly emasculated to test the function of pollen on the morphologically perfect flower by comparison with the results of the control group. Bags of MF tracing paper (approximately 20 × 20 cm in size and reinforced with nylon fiber), tested to make sure they did not allow the penetration of airborne pollen, were placed on immature inflorescences at the beginning of March and removed in mid-April when all flowers had withered. Artificial pollination was conducted by directly brushing the

stigmas of the recipient flowers with stamens from the donor. As indicated above, because many trees are too tall to carry out the various treatments, just three individuals with morphologically perfect flowers were used in 2006 and one in 2007 as the female parent, and two individuals were used as pollen donors. In general, we chose flowers from the highest part of these trees to serve as controls; flowers lower down were used to carry out the other treatments because they were easier to access and manipulate for artificial pollination. It should be noted that light intensity increases toward the top of these large trees. Mature fruits were collected from the control and the treated flowers in August.

RESULTS

FLOWER PHENOLOGY

Anthesis in *Nyssa yunnanensis* extended from February to April (Fig. 1). Staminate flowers opened 10 to 15 days earlier than the morphologically perfect ones, but flowering ceased at nearly the same time. The staminate flowers had five to seven petals, 10 to 14 stamens, and a central disc that secreted abundant nectar (Fig. 2A). The morphologically perfect flowers had four to six petals, five to seven stamens, a nectar disc that also produced abundant nectar, and a bifid style (Fig. 2B). The stamens in the staminate and the morphologically perfect flowers were similar in morphology, but they were more numerous in the staminate flowers and were arranged equidistant around the disc, forming two alternating whorls with filaments of different length (Fig. 3). Growth and the order of dehiscence of the anthers on the longer stamens were recorded on staminate flowers with five petals and 10 stamens. The order of dehiscence (shown on the left of Fig. 3) was sequentially from anthers number 1 to 5. By contrast, the short anthers in the staminate flowers did not develop and dehisce in a regular order. The stamens of the morphologically perfect flowers are equal in length, although they too can be divided into two groups. The first group includes most of the stamens, which develop early and are inserted around the disc. The second group, comprising just one or two stamens, is positioned directly on the disc and develops well after the flower opens. We refer to members of this second group as anaphase stamens (Fig. 3, right).

The life span of staminate flowers was 10 to 14 days, whereas that of the morphologically perfect flowers was slightly shorter, from 11 to 13 days. The anthers of the long stamens in staminate flowers dehisced and dispersed pollen four days after the opening of the flower; those on the short stamens

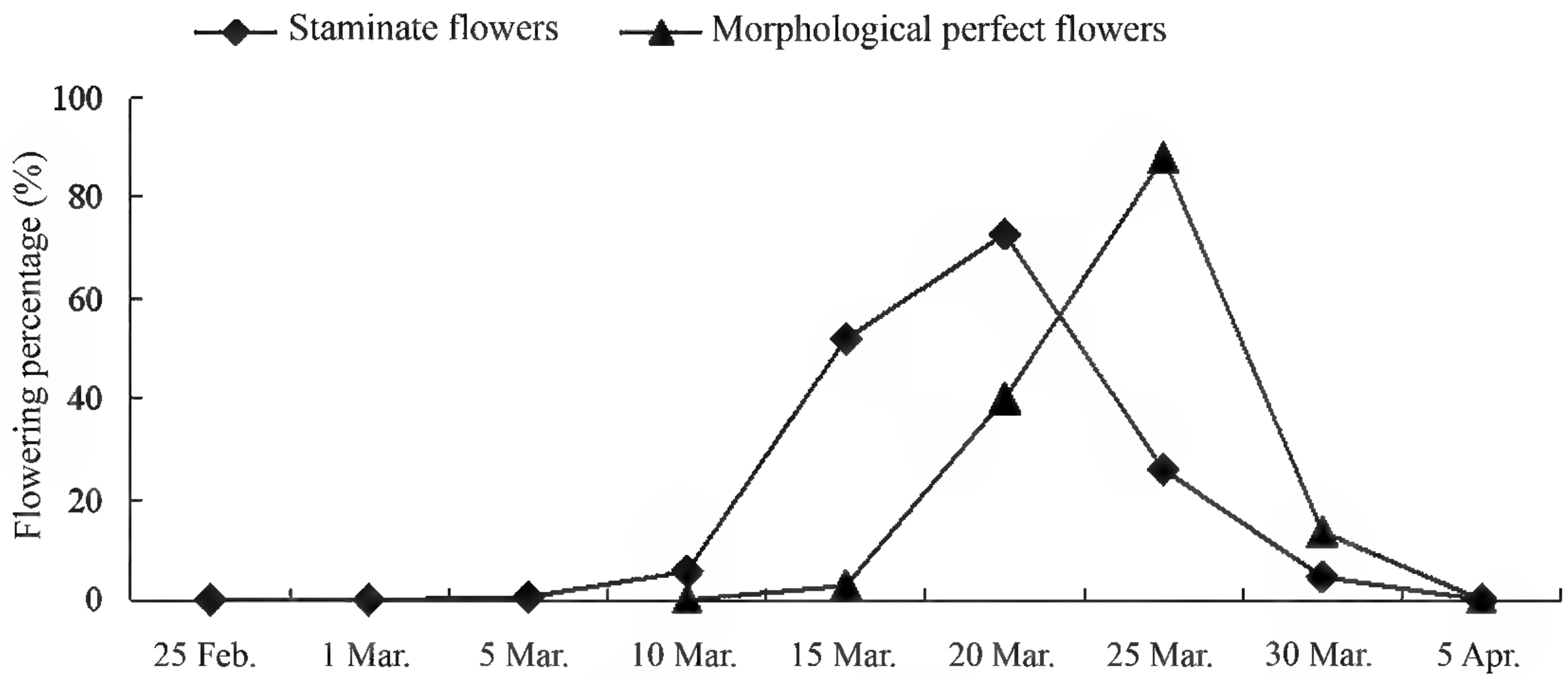

Figure 1. The flowering period of *Nyssa yunnanensis* W. Q. Yin ex H. N. Qin & Phengkklai in the studied population in 2006.

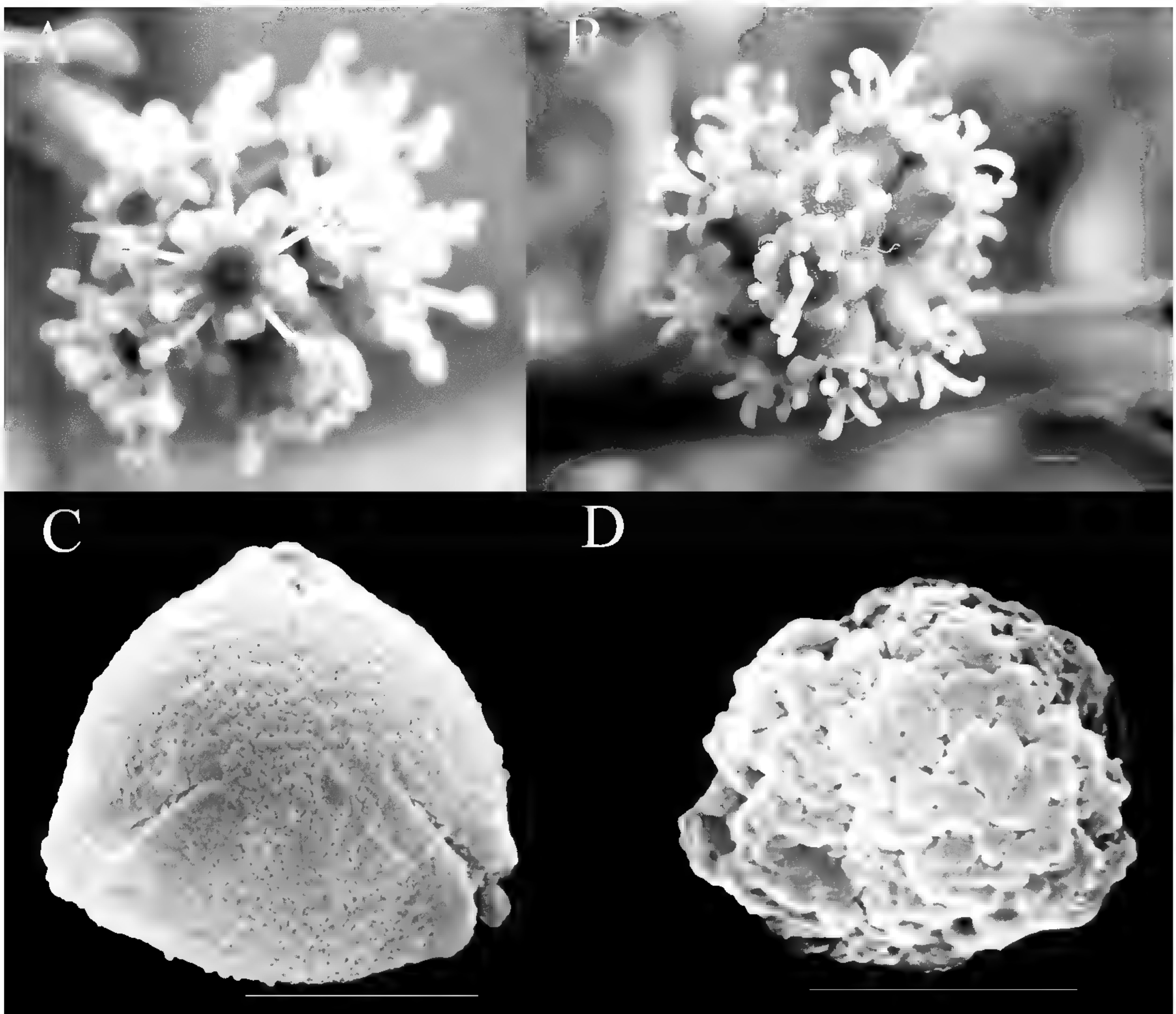

Figure 2. SEM images of flowers and pollen of *Nyssa yunnanensis* W. Q. Yin ex H. N. Qin & Phengkklai. —A. Staminate flowers. —B. Morphologically perfect flowers. —C. Pollen grain of staminate flower. —D. Pollen grain of morphologically perfect flower. Scale bars: A, B — 1 mm; C, D — 10 μ m.

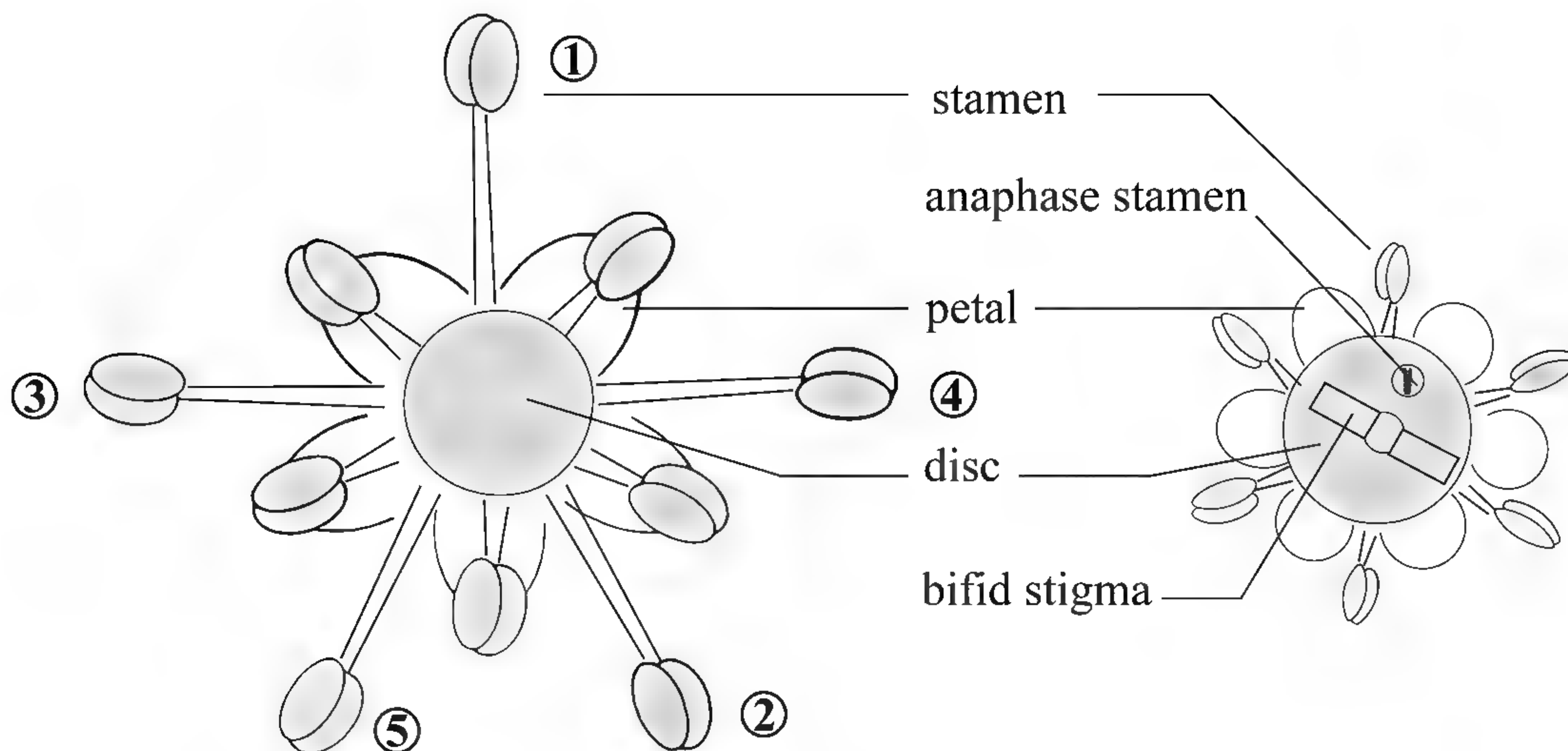

Figure 3. Flower structure of *Nyssa yunnanensis* W. Q. Yin ex H. N. Qin & Phengklai, showing staminate flower (left) and morphologically perfect flower (right) (the actual number of petals varies from five to seven in the male flower and four to six in the morphologically perfect flower).

released pollen one or two days later, after which the filaments of the short stamens elongated to reach the length of the long stamens. On the first day when the morphologically perfect flowers opened, the style was green and undivided, but after three or four days it began to become evidently bifid and the color changed from green to white, a process that took about five or six days to complete. The anthers of the morphologically perfect flowers dehisced seven or eight days after the opening of the flower. Nectar secretion began after the flower had been open two or three days and ceased when the stamens and style became brown.

POLLEN VIABILITY, STIGMATIC RECEPTIVITY, AND FLORAL SEXUAL FUNCTION

The diameter of the pollen grains from staminate flowers ranged from 25–30 μm . They were tricolporate and triangular in polar view, with scabrate and reticulate sculpturing (Fig. 2C). Morphologically perfect flowers produced only inaperturate pollen grains, which were circular in polar view (Fig. 2D). The pollen from staminate flowers germinated in a gradient series of sucrose solutions ranging from 0%–10% (Fig. 4), with the 0.5% sucrose solution yielding the best result (up to 97.4%, F5 [Levene F statistic of the

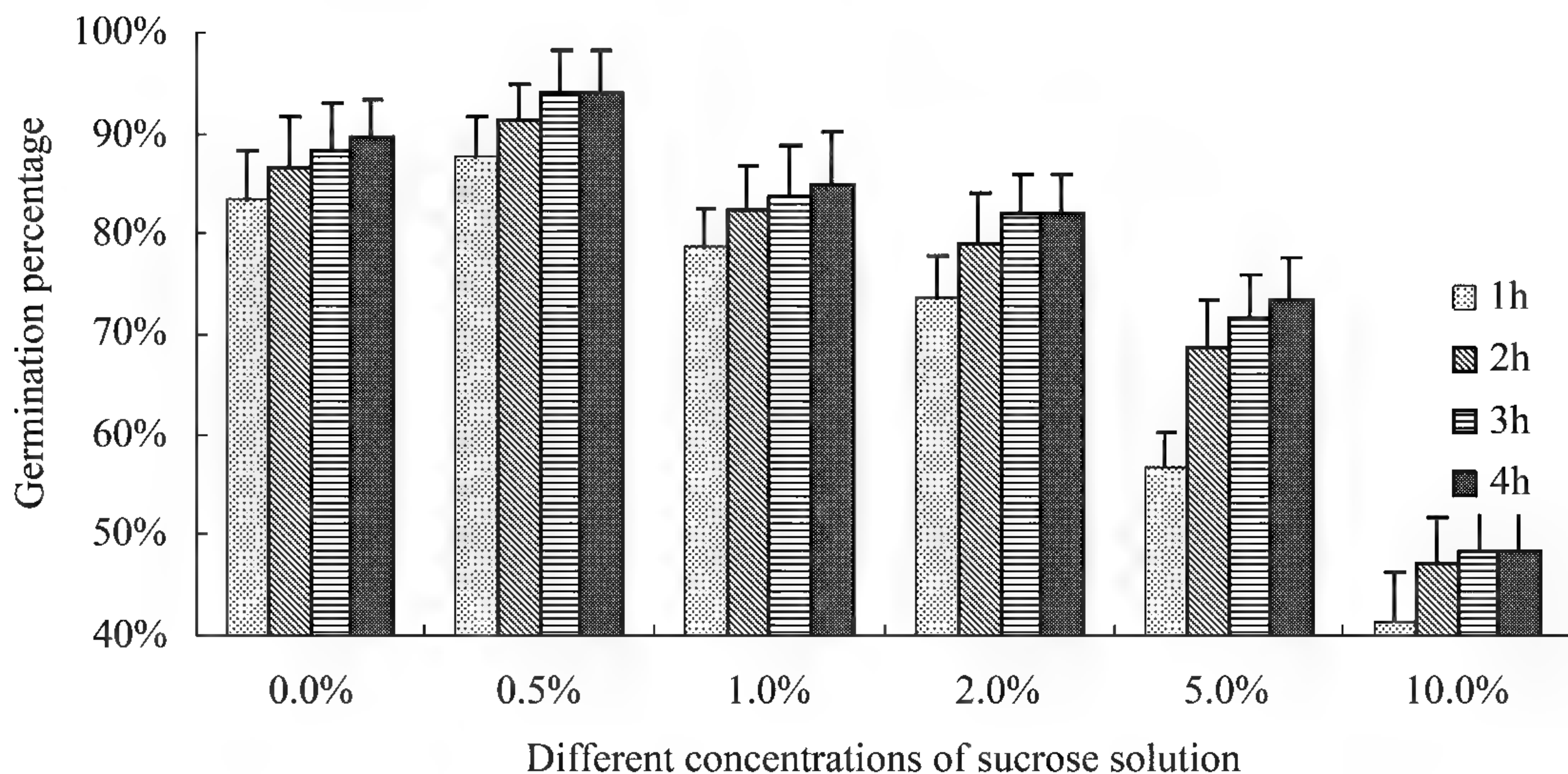

Figure 4. Pollen germination rate of *Nyssa yunnanensis* W. Q. Yin ex H. N. Qin & Phengklai in different concentrations of sucrose solution and different culture times.

Table 1. Sex ratio and flower sex ratio in three populations of *Nyssa yunnanensis*.

	Sex ratio (PR)			Flower sex ratio (PFR)		
	SP (M:H:J)	WP (M:H:J)	DP (M:H:J)	FR (n - 50)	IR (n - 40)	BR (n - 5)
Ratio	6:6:2	0:4:5	2:4:8	1.94:1	2.39:1	0.97:1
Average of three populations	0.57:1			2.56:1		

BR, branches per tree; DP, Dam population; FR, flowers per inflorescence ratios (staminate/morphologically perfect); H, morphologically perfect; IR, inflorescences per branches ratio (staminate/morphologically perfect); J, juvenile; M, staminate; PFR, population flower sex ratio (staminate/morphologically perfect) ($PFR = FR \times IR \times BR \times PR$); PR, sex ratio of plants in population; SP, Stream population; WP, Well population.

five samples] – 1.654, $P < 0.05$, using distilled water as the control). The pollen germination rate increased more or less regularly with increased cultivation time, although a slight change occurred after three hours. By contrast, no pollen from the morphologically perfect flowers germinated, regardless of sucrose concentration and culture time, indicating that these flowers are functionally female.

In morphologically perfect flowers, as indicated above, the style became receptive after changing color from green to white and then turned brown following receptivity. The stigma was receptive before dehiscence of the first group of anthers, so the morphologically perfect (and functionally female) flowers were thus protogynous.

SEX RATIO WITHIN POPULATIONS AND AMONG FLOWERS

Three populations of *Nyssa yunnanensis* are present at the Puwen Tropical Forest Station: the Stream population, the Well population, and the Dam population. When juvenile individuals were excluded, the ratio of adult male to female trees was 1:1 in the Stream population (six male, six female, and two juvenile trees), 0:1 in the Well population (zero males, four females, and five juveniles), and 1:2 in the Dam population (two males, four females, and eight juveniles) (Table 1). When all 37 individuals of *N. yunnanensis* known from the study area were considered, the overall sex ratio was 0.57:1, showing a clear female bias.

The FR – 1.94:1 (number of flowers per male inflorescence – 14.66 ± 3.27 , $n = 50$, $P \leq 0.05$; number of flowers per female inflorescence – 7.56 ± 1.34 , $n = 50$, $P < 0.01$). The IR – 2.39:1 (number of inflorescences per male branch – 4.90 ± 2.11 , $n = 40$, $P < 0.01$; number of inflorescences per female branch – 2.05 ± 1.01 , $n = 40$, $P < 0.01$). The BR – 0.97:1 (number of branches per male tree – 18.80 ± 2.86 , $n = 5$, $P < 0.01$; number of branches per female tree – 19.40 ± 2.51 , $n = 5$, $P \leq 0.05$). Finally, the overall PFR – $1.94:1 \times 2.39:1 \times 0.97:1 \times 0.57:1 = 2.56:1$, which suggests a male-biased flower sex ratio.

FLORAL VISITORS

Thirty-six insect species belonging to five families and 25 genera were collected as visitors of *Nyssa yunnanensis* flowers. Twenty species were observed on male and/or functionally female flowers (Appendix 1). Because male flowers opened before female flowers, insects were at first observed and captured visiting the former. Most insects visited flowers exclusively for nectar, and only four species were observed to carry pollen on their body and/or legs and could therefore be considered potential pollinators: *Chrysomya megacephala* Fabr. (a fly), *Apis cerana* Fabr. (a bee), Eurytomidae sp., and *Praestochrysis* Linsenmaier sp. (both chalcidoids). Pollen grains were also noted on the bodies of *Polistes* Latreille sp. and *Mutilla marginata* Baer, but these species only visited flowers occasionally and were thus not considered to be effective pollinators. Other visiting insects were observed, including syrphids, beetles, mosquitoes, and small moths, all apparently for nectar, but they neither carried pollen nor remained in the population of *Nyssa* for more than a short time, suggesting that they played little or no role in pollination.

MATING SYSTEMS

The results of the breeding experiments (Table 2) showed that fruit set from untreated flowers was higher than that from the other treatments in both of the years studied (49% in 2006 and 45% in 2007). Fruit set was zero for the following treatments: directly bagged, emasculated and bagged, emasculated and artificially self-pollinated with pollen from the same flower, and emasculated and artificially self-pollinated with pollen from another functionally female flower on the same tree. In functionally female flowers that were emasculated and artificially cross-pollinated with pollen from a staminate flower, fruit set at a rate only slightly lower than that in untreated flowers (47% in 2006 and 43% in 2007). Fruit set in functionally female flowers that were emasculated and netted was only 13% in 2006 and 15% in 2007, suggesting that

Table 2. Number of flowers and percentage fruit set in control and treated flowers of *Nyssa yunnanensis* over a two-year period (2006–2007).

Treatment	2006		2007	
	No. of flowers	Fruit set (%)	No. of flowers	Fruit set (%)
Untreated (control)	49	49	71	45
Directly bagged	27	0	24	0
Emasculated and bagged	13	0	32	0
Emasculated and artificially self-pollinated with pollen from the same flower	21	0	26	0
Emasculated and artificially self-pollinated with pollen from another morphologically perfect flower on the same tree	29	0	34	0
Emasculated and artificially cross-pollinated with pollen from a staminate flower	43	16	63	19
Emasculated and netted	15	13	46	15
Emasculated	21	47	28	43

some wind pollination can take place but that it is much less efficient than insect pollination. However, comparing fruit set between untreated (control) flowers and those that were emasculated and artificially cross-pollinated with pollen from male flowers, we found that the latter had lower fruit set (16% vs. 49% in 2006 and 19% vs. 45% in 2007).

DISCUSSION

FUNCTIONAL OR CRYPTIC DIOECY

Barrett (2002) pointed out that it is important to consider the quantitative nature of gender and adopt functional rather than morphological criteria when interpreting plant sexuality. Our study shows that *Nyssa yunnanensis* is characterized by two types of individuals, those producing staminate flowers and those with morphologically perfect flowers that produce sterile, inaperturate pollen. Such apparently androdioecious species are best interpreted as functionally dioecious. At least 78 species in 20 families were recognized by Mayer and Charlesworth (1991) to exhibit functional or cryptic dioecy, and particularly well-known examples include *Solanum appendiculatum* Dunal and *S. asymmetriphyllum* Specht (Levine & Anderson, 1986; Anderson & Symon, 1989).

Why do the morphologically perfect flowers of *Nyssa yunnanensis* bear five to seven stamens that produce inviable pollen? Perhaps to attract and deceive pollinators, as suggested by the fact that the anthers of these flowers are otherwise similar in overall morphology to those of staminate flowers, a

situation also reported in the New Caledonian species *Polyscias pancheri* (Baill.) Harms (Araliaceae) (Schlessman et al., 1990). Real (1981) reported that bees will visit artificial flowers that offer no reward of any kind, and this type of visual deception can be important to the success of some mating systems (Dafni, 1984). Batra (1999) thought the bright yellow anthers of *N. sylvatica* may be attractive to pollinators, and our results show that fruit set is higher in untreated flowers of *N. yunnanensis* than in emasculated flowers, which supports this hypothesis. Furthermore, the anthers of the functionally female flowers may also provide a landing structure for pollinators in species whose flowers have very small petals, as in *N. yunnanensis*. Thus, although the inaperturate pollen in functionally female flowers is not viable, the presence of anthers that produce pollen (albeit sterile) may nevertheless be important for the reproductive success of the species.

Our observations indicate that *Nyssa yunnanensis* is pollinated by generalist visitors such as bees and flies, and that both nectar and pollen appear to serve as rewards for them. Dioecy may be favored in forest species if pollinators are primarily generalists and if there is increased selection pressure for sex separation (Beach & Bawa, 1980). Batra (1999) reported that pollinators were attracted to the small, greenish, and odorless flowers of *N. sylvatica* by the sparkling nectar in addition to the pollen. Our field observations showed that the nectar of *N. yunnanensis* is fragrant, with an applelike smell, and that it serves as a reward for pollinators as well as other floral visitors. Hence, *N. yunnanensis* can be considered primarily a nectar-

rewarding species in which pollination relies on a system of unidirectional exploitation (Dafni, 1984), with pollen serving as a secondary reward.

PHENOLOGY

Bawa and Opler (1975) reported on the phenological patterns of dioecious trees in tropical forests and contrasted them with those of hermaphroditic taxa. A small number of dioecious species flowered during the dry season (which occurs from January to March in Yunnan), whereas the majority flowered at the dry-wet interface (April and May). *Nyssa yunnanensis* fits this pattern well. At the population level, male flowers opened earlier than functionally female flowers but completed flowering almost simultaneously. We suggest that the precocious opening of a small number of male flowers serves to attract a few early pollinators who may serve in turn to guide or attract others by virtue of their memory and learning ability (Cartwright & Collett, 1983), which may facilitate long-distance cross-pollination. Moreover, the 2-whorled androecium and the sequential dehiscence of anthers in male flowers of *N. yunnanensis* may prolong the functional life span of an individual flower and thereby increase the efficiency of out-crossing. It is possible, however, that pollen discounting may also be taking place (Harder & Wilson, 1998) because the sequence of anther maturation and dehiscence is such that the distance between a dehiscing anther and the one that will reach maturity next is maximized, while the length of time during which an anther bears pollen is shortened. This may be an effective way of making the best use of a limited resource for the plant.

In *Nyssa yunnanensis*, the number of flowers in an inflorescence differs between males and females. Anther size also differs strikingly; anthers of the male flowers are ca. 5×3 mm, whereas those of the female flowers are ca. 0.5×0.2 mm (Sun & Zhang, 2007). When differences in the total numbers of male and female flowers within an inflorescence and on an entire plant are also taken into consideration, it is clear that male individuals produce more pollen grains than female plants.

MATING SYSTEM

Because male flowers produce many more pollen grains than functionally female flowers and pollen from the latter is sterile, *Nyssa yunnanensis* can be regarded as xenogamous. Our experiments showed that fruit set was higher in untreated (control) flowers than in flowers subjected to the various treatments in our experimental protocol, especially when female flowers were emasculated and artificially pollinated

using stamens from male trees. This result may be explained by differences in the position of the flowers selected for the treatments. In general, flowers located high on a tree were left as controls and those lower down were treated because they were physically easier to access and manipulate. Because flowers positioned higher on a tree almost certainly received more light, this may have affected fruit set (Cipollini & Stiles, 1991). Parthenocarpic fruit development could, however, be ruled out in *N. yunnanensis* because no fruit was produced by flowers that were emasculated and bagged. Also, flowers that were emasculated and artificially pollinated from male individuals had lower fruit set than untreated flowers, possibly indicating out-crossing depression (see Fischer & Matthies, 1997), although this should be tested further to ensure that no errors occurred during the process of artificial pollination. Lastly, Whitehead (1969) considered that wind pollination is probably uncommon or even absent among tropical forest taxa. Our study suggests, however, that both wind and insect pollination occur in *N. yunnanensis* because fruits were produced in treatments where flowers were emasculated and netted, and fruit set was higher in emasculated flowers that were not netted. This may be related to the fact that adult trees of *N. yunnanensis* are very tall, extending above the denser parts of the forest canopy where wind speed is not significantly reduced.

SEX RATIO WITHIN POPULATION AND AMONG FLOWERS

In dioecious plant species, male and female individuals often show secondary intersexual differences that can be related to the differential constraints and selection pressures imposed on male and female functions (Lloyd & Webb, 1977). Several studies have shown that a 1:1 primary sex ratio often occurs in dioecious species (Fisher, 1930), and deviations from this have been the focus of many theoretical and empirical studies (e.g., Melampy & Howe, 1977; Shea et al., 1993; María & Ramón, 1995; Queenborough et al., 2007). Our results showed a female-biased sex ratio of 0.57:1 in *Nyssa yunnanensis*, adding to only a few previously reported cases in dioecious species (e.g., Melampy & Howe, 1977; Opler & Bawa, 1978; Sassaman, 1991). Opler and Bawa's (1978) study of tropical forest trees indicated that a female-biased sex ratio tends to occur in species whose population densities are high. However, the ratio of the total number of male to female flowers in *N. yunnanensis* shows a different pattern, with a male bias of 2.56:1. This may be explained by the fact that about twice as many flowers are produced per inflorescence on male trees, which also bear more than twice as many inflorescences per branch compared to female trees,

although the branch per tree ratio and the overall sex ratio are both less than 1:1. Differential resource allocation to reproductive function between males and females may translate into differences in trade-offs between vegetative and reproductive activities (María & Ramón, 1995). Males of *N. yunnanensis* produce more flowers than females, indirectly supporting the hypothesis that female plants incur a higher cost of sexual reproduction and that this higher cost is measurable as reduced vegetative growth (male trees bear fewer branches than females) and lower flowering frequency (also see Cipollini & Stiles, 1991).

One of the populations at the Puwen Tropical Forestry Station, the Well population, comprises only functionally female individuals and lacks male individuals altogether, yet no parthenogenesis was detected. Chase et al. (1996) reported that the longest intrapopulation gene-flow distance covered for tropical trees was approximately 350 m. If this is true for *Nyssa yunnanensis* then gene transmission must have taken place between the Stream population and the Well population, which are about 100 m from one another, although we cannot rule out the possibility that some pollen may also be transported from the Dam population located about 2.5 km away.

CONSERVATION IMPLICATIONS

Rarity in plants may be the result of intrinsic or extrinsic (environmental) factors and is mainly related to reproduction (Rabinowitz, 1981; Falk & Holsinger, 1991). Ashton (1977) indicated that apomixes or gene fixation in small populations of self-compatible individuals must be regarded as an evolutionary dead end and would preclude inevitable extinction in a continuously changing biotic environment. However, in our study, despite the very small population sizes observed in *Nyssa yunnanensis*, we found no evidence of apomixes.

Biological diversity is especially high in the humid tropics, but human interference in tropical ecosystems almost inevitably reduces species richness and is recognized as the major cause of the loss of global biodiversity (Turner et al., 1994). The highly restricted populations of *Nyssa yunnanensis* appear to have long suffered from various types of human disturbance such as the building of a dam to supply the water for people around the Puwen Tropical Forest Station and the conversion of large areas of forest to cultivate economically valuable species such as rubber, bananas, and pineapples. Moreover, although the species has been reported as valuable for construction, furniture, decoration, and as an ornamental for landscaping (Wu & Fan, 1977; Song et al., 1989), the local people regard its wood as too soft to be of much use, even as fuel, so

they simply fell the trees when clearing for agriculture. This suggests that the small population size of *N. yunnanensis* seen today may be relictual, i.e., that the 37 trees we studied may be all that remain of a once more widely distributed and abundant species whose range has been severely reduced as a result of human disturbance. If this is the case, the biased sex ratio among the remaining trees may exacerbate and further compound the extrinsic threats faced by *N. yunnanensis*, regardless of whether the observed sex ratio has always been a characteristic of the species or has resulted directly or indirectly from human-caused reduction in population size.

The long-term survival of critically endangered species such as *Nyssa yunnanensis* and hundreds of others in Yunnan Province (Gong et al., 2006) and elsewhere in China (Fu, 1989, 1992), as well as throughout eastern Asia (IUCN, 2008), is intimately dependent on developing and implementing sound in situ conservation policies (supplemented when necessary by ex situ measures such as seed banks and cultivation in botanical gardens) coupled with responsible management of natural resources and promoting improved environmental education and public awareness campaigns. In the case of *N. yunnanensis*, germination and recruitment in the three populations at the Puwen Tropical Forest Station appear to be hampered by an unnaturally dense herbaceous layer that prevents sufficient light from reaching the ground. In an effort to ensure the long-term survival of this rare local endemic, more than 200 individuals are now being grown at Puwen and at the Kunming Institute of Botany, which could be used for a coordinated program involving in situ reintroduction, reinforced local protection, and a simple program to monitor its survival and reproduction, coupled with ex situ efforts to maintain genetic diversity and promote the cultivation of trees in appropriate reserves and botanical gardens. As the present study shows, however, such efforts must be informed by research on the population structure and reproductive biology of individual species, which may also be of great importance and may become even more so as the impacts of projected global and regional climate change begin to alter many complex and often interrelated ecosystem attributes such as flowering and fruiting phenology, pollinator behavior, and microclimate.

Literature Cited

- Anderson, G. J. & D. E. Symon. 1989. Functional dioecy and andromonoecy in *Solanum*. *Evolution* 43: 204–219.
Ashton, P. S. 1969. Speciation among tropical forest trees: Some deductions in the light of recent evidence. *Biol. J. Linn. Soc.* 1: 155–196.

- . 1977. A contribution of rain forest research to evolutionary theory. *Ann. Missouri Bot. Gard.* 64: 694–705.
- Baker, H. G. & P. A. Cox. 1984. Further thoughts on dioecism and islands. *Ann. Missouri Bot. Gard.* 71: 244–253.
- Barrett, S. C. H. 2002. The evolution of plant sexual diversity. *Nat. Rev. Genet.* 3: 274–284.
- Batra, S. W. T. 1999. Native bees (Hymenoptera: Apoidea) in native trees: *Nyssa sylvatica* Marsh. (Cornaceae). *Proc. Entomol. Soc. Wash.* 101: 449–457.
- Bawa, K. S. 1980. Evolution of dioecy in flowering plants. *Annual Rev. Ecol. Syst.* 11: 15–39.
- & P. A. Opler. 1975. Dioecism in tropical forest trees. *Evolution* 29: 167–179.
- & J. H. Beach. 1981. Evolution of sexual systems in flowering plants. *Ann. Missouri Bot. Gard.* 68: 254–274.
- Beach, J. H. & K. S. Bawa. 1980. Role of pollinators in the evolution of dioecy from distyly. *Evolution* 34: 1138–1142.
- Bernardello, G. G., G. J. Anderson, L. S. Patricio, M. A. Cleland, T. F. Stuessy & D. J. Crawford. 1999. Reproductive biology of *Lactoris fernandeziana* (Lactoridaceae). *Amer. J. Bot.* 86: 829–840.
- Carpenter, R. J., J. Read & T. Jaffré. 2003. Reproductive traits of tropical rain-forest trees in New Caledonia. *J. Trop. Ecol.* 19: 351–365.
- Cartwright, B. A. & T. S. Collett. 1983. Landmark learning in bees. *J. Comp. Physiol.* 151: 521–543.
- Charlesworth, B. & D. Charlesworth. 1978. A model for the evolution of dioecy and gynodioecy. *Amer. Naturalist* 112: 975–997.
- Charlesworth, D. 1984. Androdioecy and the evolution of dioecy. *Biol. J. Linn. Soc.* 23: 333–348.
- Chase, M. R., C. Moller, R. Kesseli & K. S. Bawa. 1996. Distant gene flow in tropical trees. *Nature* 383: 398–399.
- Cipollini, M. L. & E. W. Stiles. 1991. Costs of reproduction in *Nyssa sylvatica*: Sexual dimorphism in reproductive frequency and nutrient flux. *Oecologia* 86: 585–593.
- Dafni, A. 1984. Mimicry and deception in pollination. *Ann. Rev. Ecol. Syst.* 15: 259–278.
- . 1992. *Pollination Ecology: A Practical Approach*. Oxford University Press, New York.
- Darwin, C. 1877. *The Different Forms of Flowers on Plants of the Same Species*. Appleton, New York.
- Delph, L. F. & D. E. Wolf. 2004. Evolutionary consequences of gender plasticity in genetically dimorphic breeding systems. *New Phytol.* 166: 119–128.
- Dunthorn, M. 2004. Cryptic dioecy in *Mammea* (Clusiaceae). *Plant Syst. Evol.* 249: 191–196.
- Eyde, R. H. 1963. Morphological and paleobotanical studies of the Nyssaceae. I. A survey of the modern species and their fruits. *J. Arnold Arbor.* 44: 1–59.
- . 1966. The Nyssaceae in the southeastern United States. *J. Arnold Arbor.* 47: 117–125.
- . 1988. Comprehending *Cornus*: Puzzles and progress in the systematics of the dogwoods. *Bot. Rev.* 54: 233–351.
- Falk, D. A. & K. E. Holsinger. 1991. *Genetics and Conservation of Rare Plants*. Oxford University Press, Oxford.
- Fang, W. P., Z. P. Soong & H. Y. Su. 1983. Nyssaceae. Pp. 147–157 in W. P. Fang & Z. R. Zhang (editors), *Flora Reipublicae Popularis Sinicae*, Vol. 52(2). Science Press, Beijing.
- Fischer, M. & D. Matthies. 1997. Mating structure and inbreeding and outbreeding depression in the rare plant *Gentianella germanica* (Gentianaceae). *Amer. J. Bot.* 84: 1685–1692.
- Fisher, R. A. 1930. *The Genetical Theory of Natural Selection*. Oxford University Press, Oxford.
- Fritsch, P. & L. H. Rieseberg. 1992. High outcrossing rates maintain male and hermaphrodite individuals in populations of the flowering plant *Datisca glomerata*. *Nature* 356: 633–636.
- Fu, L. G. 1989. *China Plant Red Data Book*, Vol. 1. Science Press, Beijing.
- . 1992. *China Plant Red Data Book*, Vol. 2. Science Press, Beijing.
- Gong, X., Q. T. Zhang, G. D. Tao, Z. Z. Feng, Z. H. Yang & Y. T. Liu. 2006. *Rare Plants of Yunnan in China I*. Yunnan Science and Technology Press, Kunming.
- Harder, L. D. & W. G. Wilson. 1998. A clarification of pollen discounting and its joint effects with inbreeding depression on mating system evolution. *Amer. Naturalist* 152: 684–695.
- Hu, S. Y. 1993. Experimental methods in plant embryology (I) determination of pollen viability. *Chin. Bull. Bot.* 10: 60–62.
- IUCN. 2008. *IUCN Red List of Threatened Species*. IUCN, Gland, Switzerland, and Cambridge, United Kingdom. <<http://www.iucnredlist.org>>, accessed 12 October 2008.
- Levine, D. A. & G. J. Anderson. 1986. Evolution of dioecy in an American *Solanum*. Pp. 264–273 in W. G. D'Arcy (editor), *Solanaceae: Biology and Systematics*. Columbia University Press, New York.
- Liston, A., L. H. Rieseberg & T. S. Elias. 1990. Functional androdioecy in the flowering plant *Datisca glomerata*. *Nature* 343: 641–642.
- Lloyd, D. G. 1980. Sexual strategies in plants. III. A quantitative method for describing the gender of plants. *New Zealand J. Bot.* 18: 103–108.
- & C. J. Webb. 1977. Secondary sex characters in plants. *Bot. Rev.* 43: 177–216.
- María, B. G. & J. A. Ramón. 1995. Sex ratio and sexual dimorphism in the dioecious *Borderea pyrenaica* (Dioscoreaceae). *Oecologia* 101: 59–67.
- Mayer, S. S. & D. Charlesworth. 1991. Cryptic dioecy in flowering plants. *Trends Ecol. Evol.* 6: 320–325.
- Melampy, M. & H. Howe. 1977. Sex ratio in the tropical tree *Triplaris americanus* (Polygonaceae). *Evolution* 31: 867–872.
- Opler, P. & K. Bawa. 1978. Sex ratios in tropical forest trees. *Evolution* 32: 812–821.
- Pannell, J. R. 2002. The evolution and maintenance of androdioecy. *Annual Rev. Ecol. Syst.* 33: 397–425.
- . 2005. Phenotypic plasticity and a functional vs. genetic perspective of plant gender. *New Phytol.* 168: 506–510.
- Qin, H. N. & C. Phengklai. 2007. Nyssaceae. Pp. 300–303 in Z. Y. Wu, P. H. Raven & D. Y. Hong (editors), *Flora of China*, Vol. 13 (Clusiaceae through Araliaceae). Science Press, Beijing, and Missouri Botanical Garden Press, St. Louis.
- Queenborough, S. A., D. F. R. P. Burslem, N. C. Garwood & R. Valencia. 2007. Determinants of biased sex ratios and inter-sex costs of reproduction in dioecious tropical forest trees. *Amer. J. Bot.* 94: 67–78.
- Rabinowitz, D. 1981. Seven forms of rarity. Pp. 205–217 in H. Synge (editor), *The Biological Aspects of Rare Plant Conservation*. Wiley, New York.
- Real, L. 1981. Uncertainty and pollinator-plant interactions: The foraging behavior of bees and wasps on artificial flowers. *Ecology* 62: 20–26.
- Ross, M. D. 1982. Five evolutionary pathways to subdioecy. *Amer. Naturalist* 119: 297–318.

- Sakai, A. K. & S. G. Weller. 1999. Gender and sexual dimorphism in flowering plants: A review of terminology, biogeographic patterns, ecological correlates, and phylogenetic approaches. Pp. 1–25 in M. A. Geber, T. E. Dawson & L. F. Delph (editors), *Gender and Sexual Dimorphism in Flowering Plants*. Springer, Berlin.
- Sassaman, C. 1991. Sex ratio variation in female-biased populations of Notostracans. *Hydrobiologia* 212: 169–179.
- Schlessman, M. A., P. P. Lowry II & D. G. Lloyd. 1990. Functional dioecism in the New Caledonian endemic *Polyscias pancheri* (Araliaceae). *Biotropica* 22: 133–139.
- Shea, M. M., P. M. Dixon & R. R. Sharitz. 1993. Size differences, sex ratio, and spatial distribution of male and female water tupelo, *Nyssa aquatica* (Nyssaceae). *Amer. J. Bot.* 80: 26–30.
- Song, C. S., R. Z. Xu & Q. H. Zhang. 1989. *Rare and Endangered Plants in China*. China Forestry Press, Beijing.
- Sun, B. L. & C. Q. Zhang. 2007. A revised description of *Nyssa yunnanensis* (Nyssaceae). *Acta Bot. Yunnan.* 29: 173–175.
- , ——, F. L. Zhou, F. Q. Shi & Z. K. Wu. 2007. Seed morphology and effects of different treatments on germination of the critically endangered *Nyssa yunnanensis* (Nyssaceae). *Acta Bot. Yunnan.* 29: 351–354.
- Turner, I. M., H. T. W. Tan, Y. C. Wee, A. B. Ibrahim, P. I. Chew & R. T. Corlett. 1994. A study of plant species extinction in Singapore: Lessons for the conservation of tropical biodiversity. *Conserv. Biol.* 8: 705–712.
- Wang, S. & Y. Xie. 2004. *China Species Red List, Vol. 1. Red List*. Higher Education Press, Beijing.
- Wangerin, W. 1910. Nyssaceae. Pp. 1–15 in A. Engler (editor), *Das Pflanzenreich*, Vol. 41. Wilhelm Engelmann, Leipzig.
- Webb, C. J. & D. G. Lloyd. 1980. Sex ratios in New Zealand apiooid Umbelliferae. *New Zealand J. Bot.* 18: 121–126.
- Wen, J. & T. F. Stuessy. 1993. The phylogeny and biogeography of *Nyssa* (Cornaceae). *Syst. Bot.* 18: 68–79.
- Whitehead, D. R. 1969. Wind pollination in the angiosperms: Evolutionary and environmental considerations. *Evolution* 23: 28–35.
- Wu, C. Y. & J. R. Fan. 1977. Nyssaceae. Pp. 288–293 in C. Y. Wu (editor), *Flora Yunnanica*, Vol. 1. Science Press, Beijing.
- , A. M. Lu, Y. C. Tang, Z. D. Chen & D. Z. Li. 2003. *The families and genera of angiosperms in China: A comprehensive analysis*. Science Press, Beijing.
- Yamplosky, C. & H. Yamplosky. 1922. Distribution of sex forms in the phanerogamic flora. *Biblioth. Genet.* 3: 1–62.

Appendix 1. Pollinators and visitors of *Nyssa yunnanensis*.

Species	Family	Voucher ¹	Observed on		Reward
			Male tree	Female tree	
<i>Nepitissnata adipala</i> Moore	Nymphalidae	Sun2006032806	+	+	nectar
<i>Cethosia bibles bibles</i> (Drury)	Nymphalidae	Sun2006031803	+	+	nectar
<i>Delias hyparete</i> L.	Pieridae	Sun2006031801	+	+	nectar
<i>Ypthima medusa</i> Leech	Satyridae	Sun20060315	+	+	nectar
<i>Lethe</i> Hübner sp.	Satyridae	Sun2006031601	+	+	nectar
<i>Polyhachis</i> Fr. Smith sp.	Formicidae	Sun2006032005	+	+	nectar
<i>Monomorium orientale</i> Mayr	Formicidae	Sun2006031301	+		nectar
<i>Monomoriam chinense</i> Santschi	Formicidae	Sun2006022901	+	+	nectar
<i>Apis cerana</i> Fabr.	Apidae	Sun2006030604	+	+	nectar, pollen
<i>Monomorium pharaonis</i> (L.)	Formicidae	Sun2006022805	+	+	nectar
<i>Polistes</i> Latreille sp.	Vespidae	Sun2006030601	+	+	nectar, pollen
<i>Myrmosa melanocephala</i> (Fabr.)	Tiphiidae	Sun2006031205	+		pollen
<i>Mutilla marginata</i> Baer	Tiphiidae	Sun2006031304	+	+	nectar, pollen
<i>Praestochrysis</i> Linsenmaier sp.	Chrysididae	Sun2006031603	+		nectar, pollen
Eurytomidae sp.	Eurytomidae	Sun2006030608	+		nectar, pollen
Curculionidae sp.	Curculionidae	Sun2006032801		+	nectar
<i>Dinoderus</i> Stephens sp.	Bostrichidae	Sun2006030603	+		nectar
<i>Donacia</i> Fabr. sp.	Chrysomelidae	Sun20060305	+	+	nectar
<i>Sphenocorynes</i> sp. Schönherr	Curculionidae	Sun2006031206	+		nectar
<i>Gibbium</i> Scopoli sp.	Ptinidae	Sun2006030503	+		nectar
<i>Tethina cinerea</i> Loew	Tethinidae	Sun2006031707	+	+	nectar, pollen
<i>Chrysomyia megacephala</i> Fabr.	Calliphoridae	Sun20060307	+	+	nectar, pollen
<i>Iphiaulax imposter</i> (Scopoli)	Braconidae	Sun2006032806		+	nectar
Syrphidae sp. (f)	Syrphidae	Sun2006031701	+	+	nectar
Syrphidae sp. (m)	Syrphidae	Sun2006031701	+	+	nectar
<i>Psorophory</i> sp1	Gulicidae	Sun2006030701	+		nectar
<i>Psorophory</i> sp2	Gulicidae	Sun2006030706	+		nectar
<i>Psorophory</i> sp3	Gulicidae	Sun2006030601	+		nectar
<i>Tipula</i> L. sp.	Tipulidae	Sun2006031901	+		nectar
<i>Fannia</i> Robineau-Desvoidy sp.	Fanniidae	Sun2006030702	+	+	nectar, pollen

Appendix 1. Continued.

Species	Family	Voucher ¹	Observed on		Reward
			Male tree	Female tree	
<i>Parasarcophaga</i> Johnston & Tiegs sp.	Sarcophagidae	Sun2006031204	+	+	nectar
<i>Euxesta</i> Loew. sp.	Ulidiidae	Sun2006030610	+		nectar
<i>Cobolidia fuscipes</i> (Meigen)	Scatopsidae	Sun2006030602	+	+	nectar
<i>Stratiomyia</i> sp1	Stratiomyidae	Sun2006030504	+	+	nectar
<i>Stratiomyia</i> sp2	Stratiomyidae	Sun20060301	+		nectar
<i>Blattella</i> Caudell sp.	Blattaria	Sun2006032004	+		nectar

+, visiting flower; , not visiting flower.

¹ Vouchers deposited at the Herbarium of the Kunming Institute of Botany (KUN).

SYSTEMATICS OF THE SOUTH
AMERICAN *HYPOCHAERIS*
SESSILIFLORA COMPLEX
(ASTERACEAE, CICHORIEAE)¹

Estrella Urtubey,² Tod F. Stuessy,³ and
Karin Tremetsberger⁴

ABSTRACT

The *Hypochaeris sessiliflora* complex (Asteraceae, Cichorieae) consists of nine species of the genus from South America (all in section *Achyrophorus* Scop.) that have sessile or nearly sessile flowering heads surrounded by a rosette of leaves. They occur at 1430–5100 m in elevation along the Andean chain from Venezuela to Chile and Argentina. Two species, *H. sessiliflora* Kunth and *H. meyeniana* (Walp.) Benth. & Hook. f. ex Griseb., are extremely polymorphic, and they vary conspicuously in the shape of the external phyllaries and presence or absence of different types of trichomes. They have the widest distributions (Venezuela to central Peru, and Peru to northern Chile and northwestern Argentina, respectively), they flower throughout the year, and they also are primarily associated with dry and sunny habitats. *Hypochaeris meyeniana* is characterized by retrorsely pinnatifid leaves (rarely lobate) and slightly narrower cypselar apices. *Hypochaeris hohenackeri* (Sch. Bip.) Domke and *H. taraxacoides* Ball are glabrous, whereas *H. acaulis* (J. Rémy) Britton has scattered shaggy trichomes on the leaves; all three occur in humid places, such as seeps or bogs. *Hypochaeris eriolaena* (Sch. Bip.) Reiche and *H. mucida* Domke are pubescent, with long whiplike trichomes on leaves and phyllaries, giving a niveous-tomentose appearance. *Hypochaeris echegarayi* Hieron. (white corollas) and *H. eremophila* Cabrera (yellow corollas) are two related species with shaggy trichomes on the abaxial surfaces of the phyllaries, both with considerable ecological tolerance, that grow in dry as well as humid sites. Morphological cladistic analyses suggest a hypothesis of relationships within the complex. Surprisingly, *H. acaulis* from Chile and Argentina, although fitting morphologically within the *H. sessiliflora* complex, based on amplified fragment length polymorphism (AFLP) data, clearly does not seem to belong to this group. Instead, the species ties to *H. palustris* (Phil.) De Wild. and *H. tenuifolia* (Hook. & Arn.) Griseb., also from the southern Andes. The acaulescent habit of *H. acaulis* seems best interpreted as a parallel adaptation to survival at high elevations.

RESUMEN

El complejo *Hypochaeris sessiliflora* comprende nueve especies de Sudamérica (sección *Achyrophorus* Scop.) con cabezuelas sésiles o cortamente pedunculadas y con una roseta de hojas basales. Habitan entre los 1430–5100 m a lo largo de los Andes desde Venezuela hasta el centro de Chile y el centro oeste de Argentina. Dos especies, *H. sessiliflora* Kunth e *H. meyeniana* (Walp.) Benth. & Hook. f. ex Griseb., son extremadamente polimórficas (forma de los filarios, hojas e indumento) y presentan una amplia distribución, desde Venezuela al centro de Perú, y desde Perú al norte de Chile y noroeste de Argentina, respectivamente; principalmente crecen en ambientes secos y soleados, y florecen todo el año. *Hypochaeris meyeniana* se caracteriza por las hojas pinnatífidas y retrorsas (raro lobadas) y los aquenios ligeramente adelgazados en el ápice. *Hypochaeris hohenackeri* (Sch. Bip.) Domke e *H. taraxacoides* Ball son glabras, mientras que *H. acaulis* (J. Rémy) Britton tiene hojas hispídas; estas tres especies están asociadas a ambientes húmedos (e.g., vegas y mallines). *Hypochaeris eriolaena* (Sch. Bip.) Reiche e *H. mucida* Domke son niveo-tomentosas. *Hypochaeris echegarayi* Hieron. (corolas blancas) e *H. eremophila* Cabrera (corolas amarillas) son especies afines con pubescencia hispídas, comúnmente con cabezuelas pedunculadas y con considerable tolerancia ecológica, creciendo en ambientes secos o húmedos. La hipótesis del análisis cladístico morfológico y los recientes estudios moleculares muestran al complejo *H. sessiliflora* monofilético mientras que la hipótesis basada en datos moleculares excluye a *H. acaulis* del complejo *H. sessiliflora*, donde el hábito acaule es considerado una adaptación paralela como respuesta a la sobrevivencia en la alta montaña.

Key words: *Achyrophorus*, Asteraceae, Cichorieae, *Hypochaeris*, South America.

¹ We express thanks to John McNeill and Werner Greuter for help with the nomenclature of *Hypochaeris taraxacoides*; A. Migoya and M. Theiller for illustrations of the species and H. Calveti for help with maps; the curators of BM, CONC, K, LP, LPB, M, MCNS, MO, NY, OS, P, SGO, SI, UC, US, W, and WU for loans or permission to consult herbarium material; M. Muñoz (SGO) and L. Willemse (L) for digital images of the types of *Distoecha taraxacoides* and *H. ornata* and *H. parvifolia*, respectively; F. Felbe and F. Jacquemoud for information on types at NEU and G, respectively; V. Noble, N. Hind, and S. Barrier for their assistance during visits to BM, K, and P; S. E. Freire and D. Giuliano for valuable comments on the manuscript; A. Luck for editorial help with various drafts of the manuscript; and financial support from the Consejo Nacional de Investigaciones Científicas y Técnicas (CONICET, PEI and PIP6510), Myndel Botanica Foundation, a small grant from the University of Vienna, and the Austrian National Science Foundation (FWF, grant numbers P15225-BIO and P18446-B03).

² Instituto de Botánica Darwinion, Labardén 200, San Isidro, B1642HYD, Casilla de Correo 22, Buenos Aires, Argentina. eurtubey@darwin.edu.ar.

³ Department of Systematic and Evolutionary Botany, Faculty Center Biodiversity, University of Vienna, Rennweg 14, A-1030 Vienna, Austria. tod.stuessy@univie.ac.at.

⁴ Institute of Botany, Department of Integrative Biology and Biodiversity Research, University of Natural Resources and Applied Life Sciences, Vienna, Gregor-Mendel-Straße 33, A-1180 Vienna, Austria. karin.tremetsberger@boku.ac.at.

doi: 10.3417/2006136

Hypochaeris L. consists of about 60 species of annual or perennial herbs in Asteraceae, tribe Cichorieae Lam. & DC., subtribe Hypochaeridinae Less., which are characterized by paleae on receptacles, a plumose pappus, and style branches papillose to well below the bifurcation (Fig. 1A–C). The genus has a disjunct distribution, with ca. 12 species scattered in the Mediterranean region, two in Central Europe, one in Asia, and the remainder (some 40 to 50 species) in South America. Hoffmann (1893) reduced the 10 sections of Bentham and Hooker (1873) to five, based on the number of rows of pappus bristles, shapes of heads, arrangements of phyllaries, and shapes of the cypselae. One of these sections, *Achyrophorus* Scop., is characterized primarily by having a uniseriate pappus; all species from South America fall into this group.

Previous evolutionary studies have been completed on species of *Hypochaeris* from South America. Chromosome counts from many species and populations have revealed most members of *Hypochaeris* to be diploid, with some infraspecific polyploidy, and with some species uniformly tetraploid (Baeza et al., 2000; Weiss et al., 2003; Weiss-Schneeweiss et al., 2007, 2008). Although all diploids uniformly have $2n = 8$, small karyotypic differences allow hypotheses regarding modes of cytogenetic evolution (Weiss-Schneeweiss et al., 2003). Sequences of nuclear ribosomal ITS (nrITS) and chloroplast DNA have revealed that the South American species are monophyletic and that they are closest to *H. angustifolia* Maire from Morocco (Samuel et al., 2003; Tremetsberger et al., 2005). Sequence variation within species from South America is minimal, and no clades can be recognized with high levels of confidence. Amplified fragment length polymorphism (AFLP) studies have helped reveal phyletic assemblages within the South American taxa (Tremetsberger et al., 2006), as well as indicate phylogeographic trends at the populational level in *H. acaulis* (J. Rémy) Britton, *H. palustris* (Phil.) De Willd., and *H. tenuifolia* (Hook. & Arn.) Griseb. (Tremetsberger et al., 2003a, b; Muellner et al., 2005).

Among the South American taxa, a morphologically distinctive group is formed by species that have single sessile or nearly sessile capitula nestled among a rosette of basal leaves, the so-called *Hypochaeris sessiliflora* complex. These taxa occur from Venezuela south into Chile and Argentina and occur at 1430–5100 m, usually in dry habitats or in seeps within these high Andean regions. This paper focuses on this complex as a beginning for understanding detailed morphological relationships within the South American species of *Hypochaeris*. A revision of all taxa is included plus a morphological cladistic analysis.

CLADISTIC ANALYSIS

MATERIALS AND METHODS

Morphological characters and states were obtained primarily from study of herbarium material from BM, CONC, K, LP, LPB, M, MCNS, MO, NY, OS, P, SGO, SI, UC, US, W, and WU, plus our additional collections and field observations. Trichomes and stomatal types and terminology are used according to Metcalfe and Chalk (1950, 1979), Uphof (1962), and Harris and Harris (1994). For study of vascularization of corollas and cypselae, the clearing and staining method of Fuchs (1963) was used. Information regarding color, habitat, and phenology of plants was taken from specimen labels, the literature, and our field observations. Chromosome numbers were obtained from the reviews of Weiss et al. (2003) and Weiss-Schneeweiss et al. (2007, 2008).

The ingroup consisted of all nine South American species of the *Hypochaeris sessiliflora* complex: *H. acaulis*, *H. echegarayi* Hieron., *H. eremophila* Cabrera, *H. eriolaena* (Sch. Bip.) Reiche, *H. hohenackeri* (Sch. Bip.) Domke, *H. meyeniana* (Walp.) Benth. & Hook. f. ex Griseb., *H. mucida* Domke, *H. sessiliflora* Kunth, and *H. taraxacoides* Ball. We included five additional South American species of *Hypochaeris* to serve as outgroup. These species were selected to represent morphological diversity within *Hypochaeris* on the continent, two of which (*H. hookeri* Phil. and *H. caespitosa* Cabrera) are believed to be close relatives of the *H. sessiliflora* complex. *Hypochaeris hookeri* is closely related morphologically to the complex (especially in its acaulescent habit). Its leaves are long, linear, and erect, the peduncle is shorter than the leaves, and the paleae have trichomes on the adaxial surface; it is distributed in central-western Argentina and central-eastern Chile. *Hypochaeris caespitosa* is also an acaulescent herb, the peduncle is longer than the leaves, and it inhabits the mountain ranges of central Argentina. We also examined three caulescent species, *H. argentina* Cabrera of central Argentina, and *H. chillensis* (Kunth) Hieron. and *H. elata* (Wedd.) Benth. & Hook. f. ex Griseb. from Peru, south into Argentina.

To provide a context for selection of characters and states in the cladistic analysis, and to better clarify the character data used in the descriptions of each taxon, a sketch of the morphology of the complex follows here (see also Fig. 1). All nine species of the *Hypochaeris sessiliflora* complex are dwarf perennial herbs, from only 1 cm (*H. mucida*) to 13 cm (in *H. sessiliflora*) tall. They are acaulescent plants with thick rhizomes and rosette leaves. The capitula are always solitary, and they can be sessile or shortly

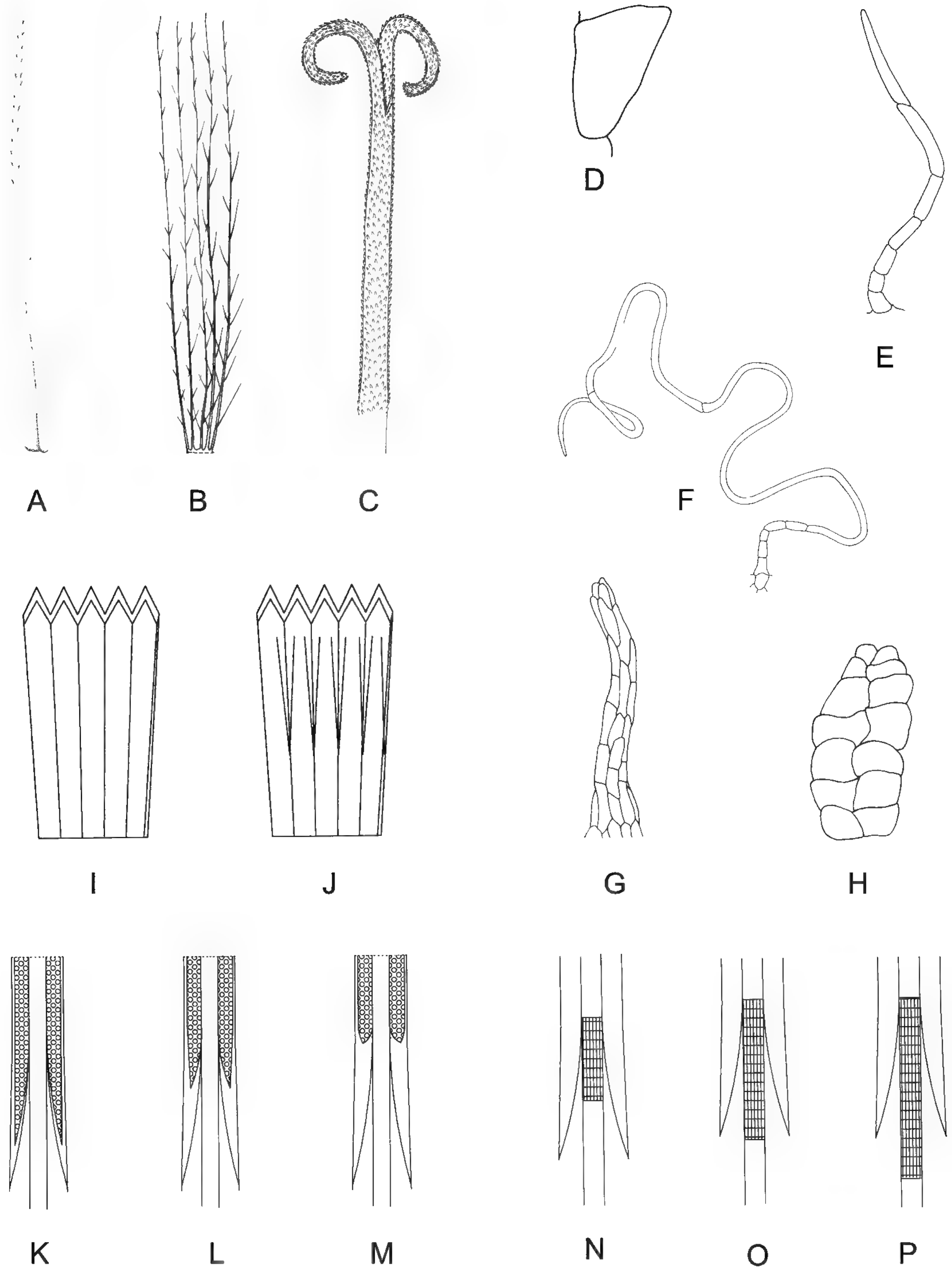

Figure 1. Selected morphological features of taxonomic efficacy in the *Hypochaeris sessiliflora* complex. —A. Palea. —B. Plumose pappus bristles. —C. Papillose style. D–H. Trichomes. —D. Papillate. —E. Conical (many-celled). —F. Whip. —G. Shaggy. —H. Glandular. I, J. Corolla vascularization. —I. Type 1. —J. Type 2. K–M. Anther tails. —K. Type 1. —L. Type 2. —M. Type 3. N–P. Basal appendages. —N. Type 1. —O. Type 2. —P. Type 3.

pedunculate (never longer than the leaves). The leaves are entire or pinnatisect, the leaf base is attenuate in a long petiole and tomentose, and the blades are commonly lanceolate or linear to elliptic. The leaf margin is entire or dentate. The epidermal cells are lightly undulate, and the stomata are anomocytic.

The involucre is commonly campanulate, campanulate-cylindrical (*Hypochaeris eremophila*), or cylindrical (*H. taraxacoides*), and sometimes hemispheric (*H. acaulis*, *H. meyeniana*, and *H. sessiliflora*). The phyllaries are in three to six series. The outer ones are lanceolate to broadly ovate, often becoming gradually lighter toward the hyaline margin. The maximum expression of this character state occurs in some populations of *H. sessiliflora* in which the apical margin is broadly expanded, called "cucullate" (hooded), and it can be entire or divided. The phyllaries are either glabrous or ciliate, sometimes lanuginous (whip trichomes) and/or setaceous (shaggy trichomes). The adaxial side of the paleae is glabrous.

The corolla is of typical Lactuceae-type, i.e., ligulate and 5-lobed, with epidermal cells lightly undulate and with epicuticular plated waxes (very conspicuous in *Hypochaeris mucida*), and it has short trichomes on the middle third. The vascularization of corollas is characterized by the adjacent marginal bundles united and fused at the apex of their lobes, and there are two different types of vascularization. The most common pattern has five marginal bundles united at the apex of the lobes (type 1, Fig. 1I); the other type comprises the same number of bundles, but these are repeatedly divided in the throat and ligule of the corolla (type 2, Fig. 1J). The color of the corolla varies: white in *H. echegarayi* and *H. taraxacoides*; yellow in *H. acaulis*, *H. eremophila*, and *H. hohenackeri*; or white, yellow, or orange in *H. eriolaena* and *H. sessiliflora*. Some plants with pink corollas in *H. hohenackeri* and *H. sessiliflora* have been collected. We have no information about the corolla color of *H. mucida*, because the available specimens are too faded, none of the herbarium labels mention the color, and we have not collected the taxon.

The five stamens have short anther tails, with basal appendages with pollen sacs extending almost to the end (1/2 to 3/4, Fig. 1K), into the middle or less (1/4 to 1/2, Fig. 1L), or basal appendages with only sterile cells (Fig. 1M). The antheropodium consists of epidermal cells that are axially elongated with thickened and lignified walls, and it can be shorter than, the same length as, or longer than the basal appendages (Fig. 1N–P).

The cypselae are commonly erostrate or narrowed toward the apex; in *Hypochaeris acaulis* they are rostrate. The cypselae are usually 5-ribbed (some-

times inconspicuous), and the surface is smooth or scaly and striate.

Five types of trichomes are present, three being uniseriate: (1) papilla-like (Fig. 1D), a small unicellular epidermal cell thickened at the apex, being present on lobes of the corolla; (2) conical (Fig. 1E), 2- to many-celled, e.g., on the margins of the palea or pappus bristles (2-celled), or comprising the cilia of the phyllaries (2- to many-celled); and (3) whip (Fig. 1F), many-celled, with a very long apical cell, present on the surfaces of leaves and phyllaries of *Hypochaeris eriolaena* and *H. mucida*. Other types of trichomes are multiseriate: (1) shaggy (Fig. 1G), many-celled, ending in one to few cells, forming a setaceous indumentum (these trichomes are often brown or red, i.e., on phyllaries of *H. echegarayi*, *H. eremophila*, and *H. sessiliflora*); and (2) biseriate-glandular (Fig. 1H), present on the leaf surface of some populations of *H. sessiliflora*. We have used the term glabrous when trichomes are relatively few or totally absent.

From this spectrum of morphological variation, 16 morphological characters (five vegetative and 11 floral) were selected for assessing evolutionary relationships among the taxa. These are listed in Appendix 1, and selected features are highlighted in Figure 1. Autapomorphic characters were not included in the analysis. The data matrix of the 14 species and 16 characters is given in Appendix 2; vouchers are listed in Appendix 3. A complete listing of specimens cited in this study is presented in Appendix 4. Polymorphisms represent nearly 20% of the data. Character 2 was uninformative within the complex, but it was included because it is important for circumscribing all the caulescent species of *Hypochaeris*.

Phylogenetic analyses were performed with PeeWee 3.0 (Goloboff, 1998). Initial PeeWee runs were conducted using sequence commands holding 10000: rseed 0, hold/40, poly-, amb-; mult*500; fit* – fit rescaled. All characters were weighted equally and character states were treated as unordered. Jackknife support values for nodes were calculated with 1000 replicates, two search replicates (mult*2), and two starting trees per replication (hold/2). Character distributions were studied and strict consensus trees were calculated using Winclada (Nixon, 1999).

RESULTS

The analyses resulted in one most parsimonious tree of 40 steps, with fit – 110 and fit* – 57%; synapomorphies and homoplasies are mapped onto the phylogeny (Fig. 2). All species except *Hypochaeris argentina* are supported by the presence of type 1

corolla vascularization (character 11, state 1). The pair *H. chillensis*–*H. elata* is supported by corollas with the same length as the involucre (character 10, state 1) and a jackknife value of 64. *Hypochaeris caespitosa* and the rest of the species are supported by possessing linear-lanceolate leaf laminae (character 3, state 4), whip trichomes on the abaxial surface of the phyllaries (character 9, state 1), and smooth cypselar walls (character 15, state 1). *Hypochaeris hookeri* is the sister species of the ingroup, a clade supported by acaulescent plants or plants with shortly pedunculate heads (character 1, state 1) and jackknife support of 56. The *H. sessiliflora* complex is supported as a monophyletic clade by glabrous phyllaries and paleae (character 9, state 3 and character 16, state 1) and with jackknife support of 59, and *H. sessiliflora* is the basal species. The clade of the remaining species is supported by linear leaves (character 3, state 1). *Hypochaeris hohenackeri* through *H. acaulis* are supported by lanceolate phyllaries (character 8, state 1). The clade of *H. mucida* and the rest of the species is supported by sessile heads (character 7, state 1). The remaining three groups are supported primarily by homoplasies, the first homoplasy being a reversal (scaly cypselar wall, character 15, state 0), followed by a parallelism (divided leaves, character 4, state 2). The unresolved complex consisting of *H. meyeniana*, *H. echegarayi*, and *H. eremophila* is supported by a reversal (lanceolate leaves, character 3, state 0) and one synapomorphy (shaggy phyllaries, character 9, state 2).

DISCUSSION

Hypochaeris hookeri appears as the sister species of the ingroup. Future studies, including the rest of the South American species, must evaluate whether *H. hookeri* should properly belong to the *H. sessiliflora* complex or not. The results tentatively support monophyly of the *H. sessiliflora* complex, but for a critical morphological assessment of this question, a cladistic analysis of all South American taxa must be completed.

The basic structure of relationships (Fig. 2) makes considerable sense. *Hypochaeris sessiliflora* is a large, acaulescent herb that contains conspicuous morphological variation (Fig. 3) and has a broad range in the northern Andes (Fig. 4A). *Hypochaeris taraxacoides* and *H. hohenackeri* are very close relatives morphologically (cf. Figs. 5, 6) and are found in similar seeps above 2600 m in the central Andes (Fig. 4B, squares and circles). Their evolutionary history must be closely entwined.

Hypochaeris mucida and *H. eriolaena* are both very tomentose with sessile heads (Figs. 7, 8). They are easily distinguished from each other in features of the

involucre, corolla vascularization, and cypselar wall. *Hypochaeris mucida* is a dwarf herb, up to only 1.5 cm tall, densely pubescent, with shaggy and whip trichomes on the backs of the phyllaries and leaves, and growing above 4500 m in grassy steppes associated with *Pycnophyllum* J. Rémy (Caryophyllaceae Juss.) in southeastern Peru and northwestern Bolivia on the eastern side of Lake Titicaca (Fig. 4B, triangles). *Hypochaeris eriolaena* has whip trichomes on the backs of the phyllaries and leaves (or glabrous), and it inhabits dry places (between 2200 and 5100 m) from Peru to Bolivia (Fig. 4C, squares).

The other rosette taxa with divided leaves, *Hypochaeris meyeniana*, *H. echegarayi*, and *H. eremophila*, are closely related. Morphologically, the last two are similar (Figs. 9, 10), both with relatively short peduncles, very divided leaves, phyllaries with long trichomes on the midribs (Figs. 10C, D; 11C–E), and plumose pappus bristles. They have different and consistent floral colors: white versus yellow, respectively. They are also both found in the junction between southern Peru, southwestern Bolivia, and northwestern Argentina. It is very likely that these two taxa share a common origin. *Hypochaeris meyeniana* is similar to the other two, but its heads are subsessile, leaves less divided, phyllaries nearly glabrous, and pappus bristles with very short side trichomes (Fig. 11).

Hypochaeris acaulis, which occurs only in the southern Andes (Figs. 12, 13), is geographically far removed from the other taxa of the *H. sessiliflora* complex. Although morphologically *H. acaulis* fits comfortably within this complex (it can be differentiated from the other species of this complex by its broader phyllaries and rostrate cypselae; Fig. 12; see also key), recent AFLP data do not support this inclusion. Based on a broad sampling of taxa of *Hypochaeris* within South America (but not including *H. mucida* due to lack of material), Tremetsberger et al. (2006) have shown that *H. acaulis* does not at all relate to the *H. sessiliflora* complex, but instead to *H. palustris* and *H. tenuifolia*, which are also found at high elevations along volcanoes of the southern Andes in Chile and Argentina (Tremetsberger et al., 2003a, b; Muellner et al., 2005). This makes sense geographically. *Hypochaeris acaulis* appears to represent a case of extreme morphological parallelism as adaptation for survival against the harsh environment (especially low temperatures and wind). *Hypochaeris acaulis* is included here for convenience; it will be separated in a future comprehensive treatment of the entire South American complex of the genus.

Considering the classical biogeographic division of the Andes into three portions (Morrain, 1984; Taylor, 1991), the northern Andes (10°N to 3°S), central

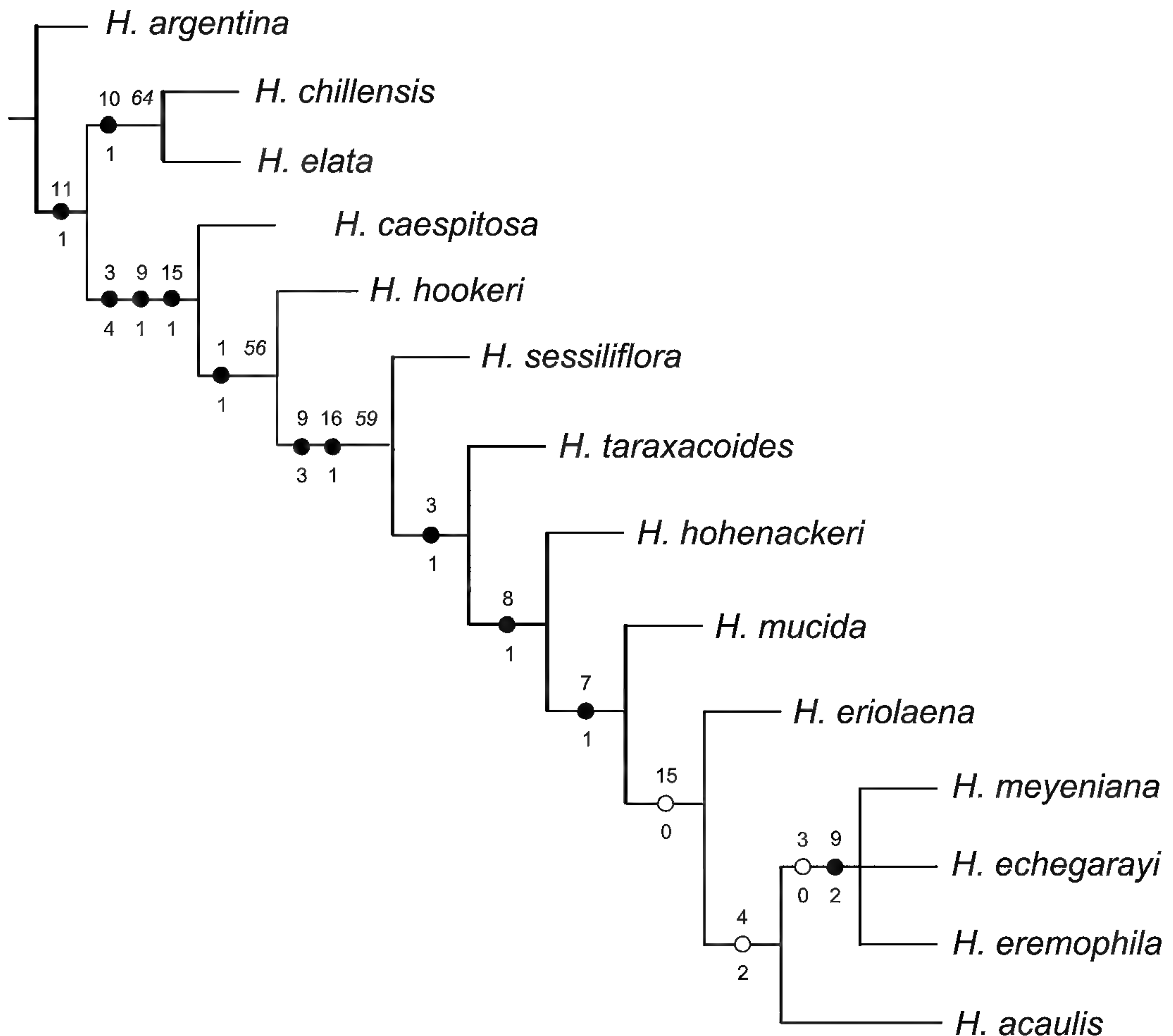

Figure 2. Most parsimonious tree of 40 steps (fit = 110; fit* = 57%), showing all characters (numbers above line) and states (numbers below line; see Appendix 1) for clades. Closed circles indicate synapomorphies; open circles indicate homoplasies (parallelisms or reversals). The numbers in italics are jackknife support values greater than 50% taken from a strict consensus tree.

Andes (3°S to 18°S), and southern Andes (18°S to 54°S), only *H. sessiliflora* is present in the northern Andes (Fig. 4A). *Hypochaeris acaulis* is the only taxon in the southern Andes; as discussed above, it appears to have had an independent evolutionary history. Most of the species of the complex occur in the central Andes; the major evolutionary and biogeographic differentiation must have occurred in this general region. Exactly what the mechanisms of speciation and biogeography have been in this subgroup remain to be determined; they likely have involved dispersal throughout the zone, isolation due to diverse topography, adaptation to local ecologic conditions, and eventual local speciation. Suspected hybridization between *H. echegarayi* and *H. meyeniana* (pers. field obs.) in western Bolivia emphasizes the evolutionary

closeness of this group and perhaps also its recent evolutionary origins.

TAXONOMIC TREATMENT

Hypochaeris L., Sp. Pl. 2: 810. 1753. TYPE:
Hypochaeris glabra L.

The genus *Hypochaeris* is characterized by the presence of latex, ligulate corollas, receptacular paleae, and a plumose pappus. It comprises approximately 60 species with an important center of diversification in South America (where more than 2/3 of the species occur). The rest of the taxa inhabit the Old World and Asia. All South American species fall under section *Achyrophorus*, characterized by the presence of a uniseriate pappus.

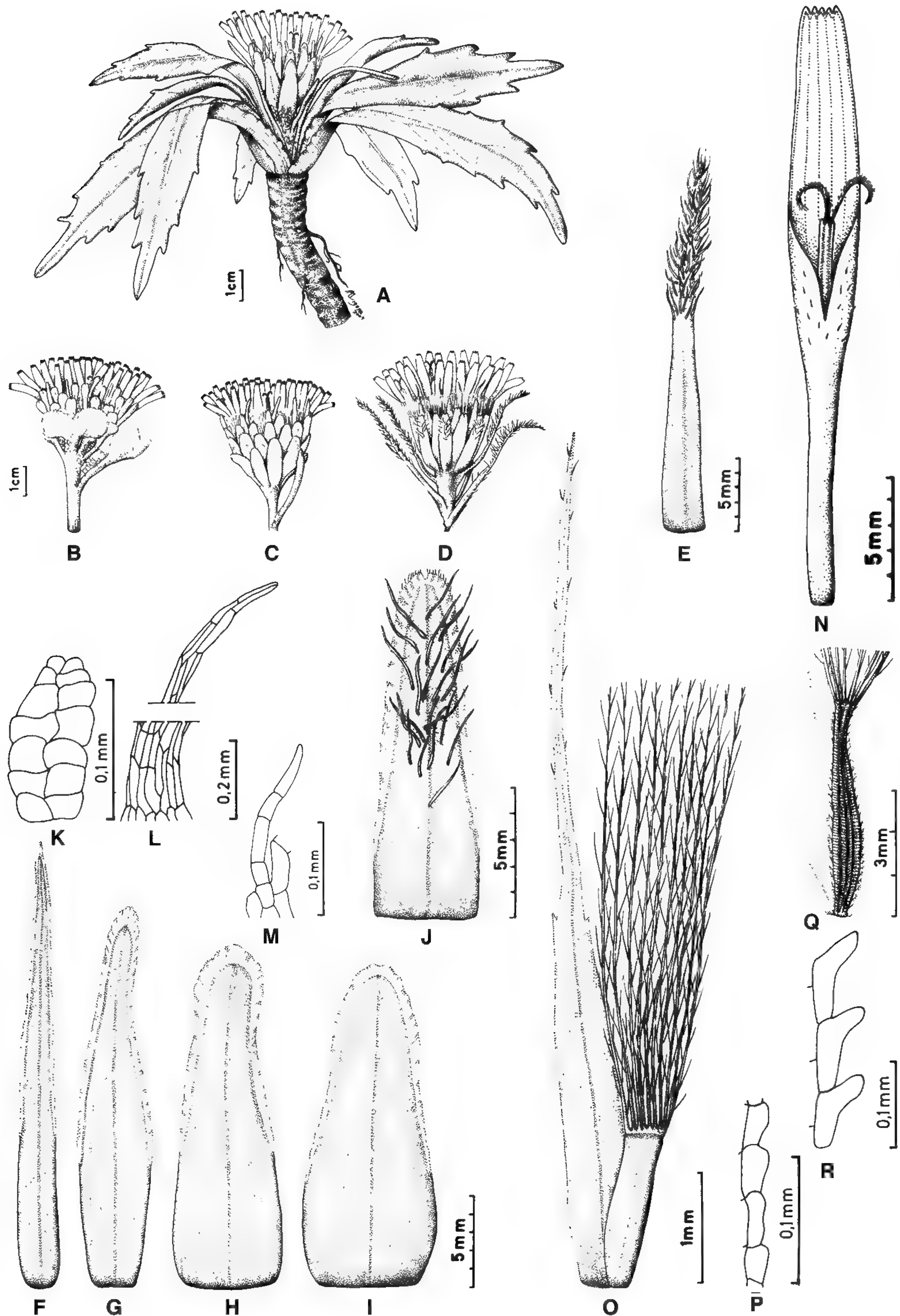

Figure 3. *Hypochaeris sessiliflora*. —A. Habit. —B–D. Variation in capitula and phyllaries. —E. Setaceous bract. —F–J. Phyllaries. K–M. Trichomes occurring on some phyllaries. —K. Glandular trichomes. —L. Shaggy trichomes. —M. Conical trichomes. —N. Corolla with anthers and style. —O. Palea, cypselae, and pappus. —P. Smooth achenial wall. —Q, R. Scaly cypselar wall. A, C, F–I, N–P from *Cuatrecasas et al.* 25599 (US); B from *Stuessy et al.* 18538 (LP); and D, E, J–M, Q, R from *Plowman* 1955 (US).

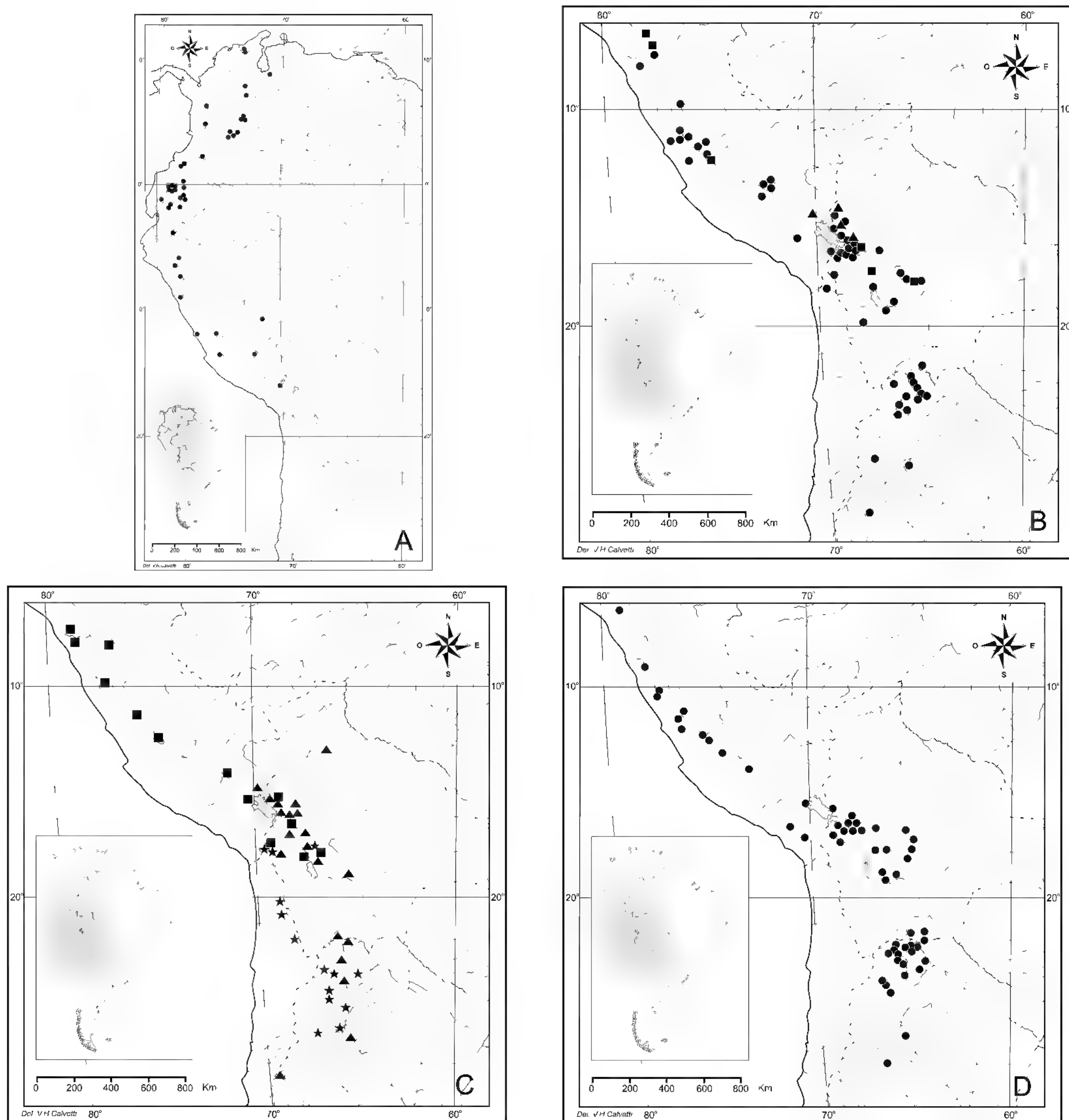

Figure 4. —A. Distribution of *Hypochaeris sessiliflora* in the northern and central Andes. —B. Distribution in the central and northern Andes of *H. hohenackeri* (■), *H. mucida* (▲), and *H. taraxacoides* (●). —C. Distribution in the central Andes of *H. echegarayi* (▲), *H. eremophila* (★), and *H. eriolaena* (■). —D. Distribution of *H. meyeniana* in the central Andes.

The *Hypochaeris sessiliflora* complex comprises nine South American species of dwarf (1–13 cm tall), perennial, acaulescent herbs, with solitary capitula that are sessile or pedunculate (shorter than the

leaves), which inhabit dry and humid places along the Andean mountains, from southern Venezuela to central-eastern Chile and northwestern Argentina, between 1430 and 5100 m.

KEY TO SPECIES OF THE *HYPOCHAERIS SESSILIFLORA* COMPLEX

- 1a. Outer phyllaries broadly ovate (as wide as long); cypselae rostrate, proximally scaly 9. *H. acaulis*
- 1b. Outer phyllaries usually longer than wide; cypselae erostrate or narrower near apices, scaly or smooth.
 - 2a. Involucre cylindrical; corollas white 2. *H. taraxacoides*
 - 2b. Involucre campanulate-cylindric, campanulate to hemispheric, corollas yellow (white in *H. echegarayi*, sometimes white in *H. sessiliflora*).
 - 3a. Plants to 1.5 cm tall; phyllaries with both whip and shaggy trichomes 4. *H. mucida*
 - 3b. Plants 3–13 cm tall; phyllaries glabrous or with only one type of trichome.
 - 4a. Leaves undivided (margins entire or dentate).

- 5a. Outer phyllaries lanuginous (whip trichomes) toward the apex 5. *H. eriolaena*
- 5b. Outer phyllaries glabrous or setulose (shaggy trichomes).
 - 6a. Leaves linear-lanceolate or elliptic-lanceolate 1. *H. sessiliflora*
 - 6b. Leaves oblong 3. *H. hohenackeri*
- 4b. Leaves pinnatipartite to pinnatisect.
 - 7a. Corollas white 7. *H. echegarayi*
 - 7b. Corollas yellow.
 - 8a. Heads usually sessile; involucre campanulate 6. *H. meyeniana*
 - 8b. Heads usually pedunculate; involucre cylindric-campanulate 8. *H. eremophila*

1. *Hypochaeris sessiliflora* Kunth, Nov. Gen. Sp. [HBK], folio ed. 4: 2. 1818, quarto ed. 4: 2. 1820. *Oreophila sessiliflora* (Kunth) D. Don, Trans. Linn. Soc. London 16: 178. 1830. *Achyrophorus sessiliflorus* (Kunth) DC., Prodr. (DC.) 7: 95. 1838. TYPE: Ecuador. Prov. Pichincha: "crescit in alta convalli Quitensi, juxta montem ignivomum Pichincha, alt. 1500 hex." [ca. 3000 m], 14 Apr. 1802 [Sandwith, 1926], *F. W. H. A. von Humboldt & A. J. G. Bonpland s.n.* (holotype, P!, P photo MO!). Figure 3.

Hypochaeris sonchoides Kunth, Nov. Gen. Sp. [HBK], quarto ed. 4: 2. 1818, quarto ed. 4: 2. 1820. *Achyrophorus sonchoides* (Kunth) DC., Prodr. (DC.) 7: 95. 1838. *Achyrophorus quitensis* Sch. Bip. var. *sonchoides* (Kunth) Wedd., Chlor. And. 1: 219. 1857. TYPE: Ecuador. Prov. Pichincha: "crescit cum praecedente," 14 Apr. 1802 [Sandwith, 1926], *F. W. H. A. von Humboldt & A. J. G. Bonpland s.n.* (holotype, P!, P photos LP!, MO!).

Achyrophorus barbatus Sch. Bip., Jahresber. Pollichia 16–17: 48. 1859. *Achyrophorus sessiliflorus* (Kunth) DC. var. *barbatus* (Sch. Bip.) A. Gray, Proc. Amer. Acad. Arts 5: 146. 1861. *Hypochaeris barbata* (Sch. Bip.) Reiche, Anales Univ. Chile 116: 589. 1905. TYPE: Colombia. Dept. Norte de Santander: "Nova Granada, prov. Pamplona in Paramo de San Urban," 11,000 ft., Dec. 1842, *J. J. Linden 746* (lectotype, designated here, P!; isotypes, BM [2]!, K [2]!, P!, W!, W photo MO!).

Hypochaeris stuebelii Hieron., Bot. Jahrb. Syst. 21: 373. 1896. TYPE: Ecuador. Prov. Napo: "crescit in Páramo montis Antisana," Oct. 1871, *M. A. Stübel 184b* (holotype, B [presumably destroyed], B photos LP!, MO!).

Herbs to 13 cm tall. Leaves linear-lanceolate or elliptic-lanceolate, 20–130 × 5–25 mm, attenuate in a broad petiole with conical trichomes, margins dentate to slightly dentate, both surfaces glabrous or with some glandular trichomes. Capitula sessile or pedunculate (to 10 cm); bracts on peduncle linear, with long shaggy trichomes to 6 mm or glabrous; involucre campanulate to hemispheric, 13–25 × 10–25 mm; phyllaries 3- to 4-seriate; outer and middle phyllaries oblong-lanceolate to lanceolate, 7–15 × 2–4 mm, with shaggy trichomes on midribs to near apex or glabrous, at margins ciliate; inner phyllaries linear-lanceolate to linear, 11–25 × 2–4 mm, glabrous or sparsely ciliate at margins, often divided at the apex; paleae 12–23 mm; florets ca. 25. Corollas usually

yellow or white, rarely orange or purple, 12–27 mm; tube 5.5–13 mm; ligule 6.5–14 mm; vascularization type 1; stamens 7–19 mm; anthers 2.5–9 mm; basal appendages types 2 and 3, 0.5–1 mm; filaments 5–14 mm; antheropodium types 1 and 2. Styles 9–22 mm with branches 1–2.5 mm. Cypselae 5-ribbed, semirostrate, rostrate, or erostrate, 2–7 mm; walls scaly or smooth; pappus 7–18 mm. Chromosome numbers $2n = 8, 16$ (Jansen & Stuessy, 1980; Olsen, 1980; Weiss et al., 2003; Weiss-Schneeweiss et al., 2007, 2008).

Habitat and distribution. *Hypochaeris sessiliflora* has been found from Venezuela to Bolivia, in drier places, between 2000 and 4500 m (Fig. 4A).

Phenology. *Hypochaeris sessiliflora* flowers throughout the year.

Common names. "Achicoria" (Ecuador, *Peñafiel et al. 382*); "cachu-cachu" (Peru, *Macbride & Featherstone 1791*); "chicorea" (Colombia, *Soejarto 494*); "chicoria" (Venezuela, *Jahn 146*); "chicoria blanca" (Venezuela, *Aristeguieta 2438*). The white latex is reported as being used for toothache (Ecuador, *Ellemann 91672*).

Morphological characters. *Hypochaeris sessiliflora* is distinguished from other species of the complex by having leaves that are linear-lanceolate (or less often elliptic-lanceolate), glabrous, and toothed or slightly toothed at the margin, and cypselae that are cylindrical.

Hypochaeris sessiliflora is the most polymorphic with respect to vegetative and reproductive characters (especially shape and pubescence of leaves and phyllaries, and variation in floral color) of all members of the *H. sessiliflora* complex (Fig. 3B–D). The heads can be pedunculate (to 10 cm) or sessile, the outer phyllaries can have the margin hyaline or opaque, and in some populations (described as *H. stuebelii* by Hieronymus, 1896) the phyllaries are inflated with the apex either divided or entire. Another variable character is the color of corollas, with white, yellow, or rarely purple often encountered in the same population. *Hypochaeris sessiliflora* var. *barbata* (described as *Achyrophorus barbatus*, Schultz Bipontinus, 1859) was characterized by having linear peduncular bracts with long shaggy trichomes to

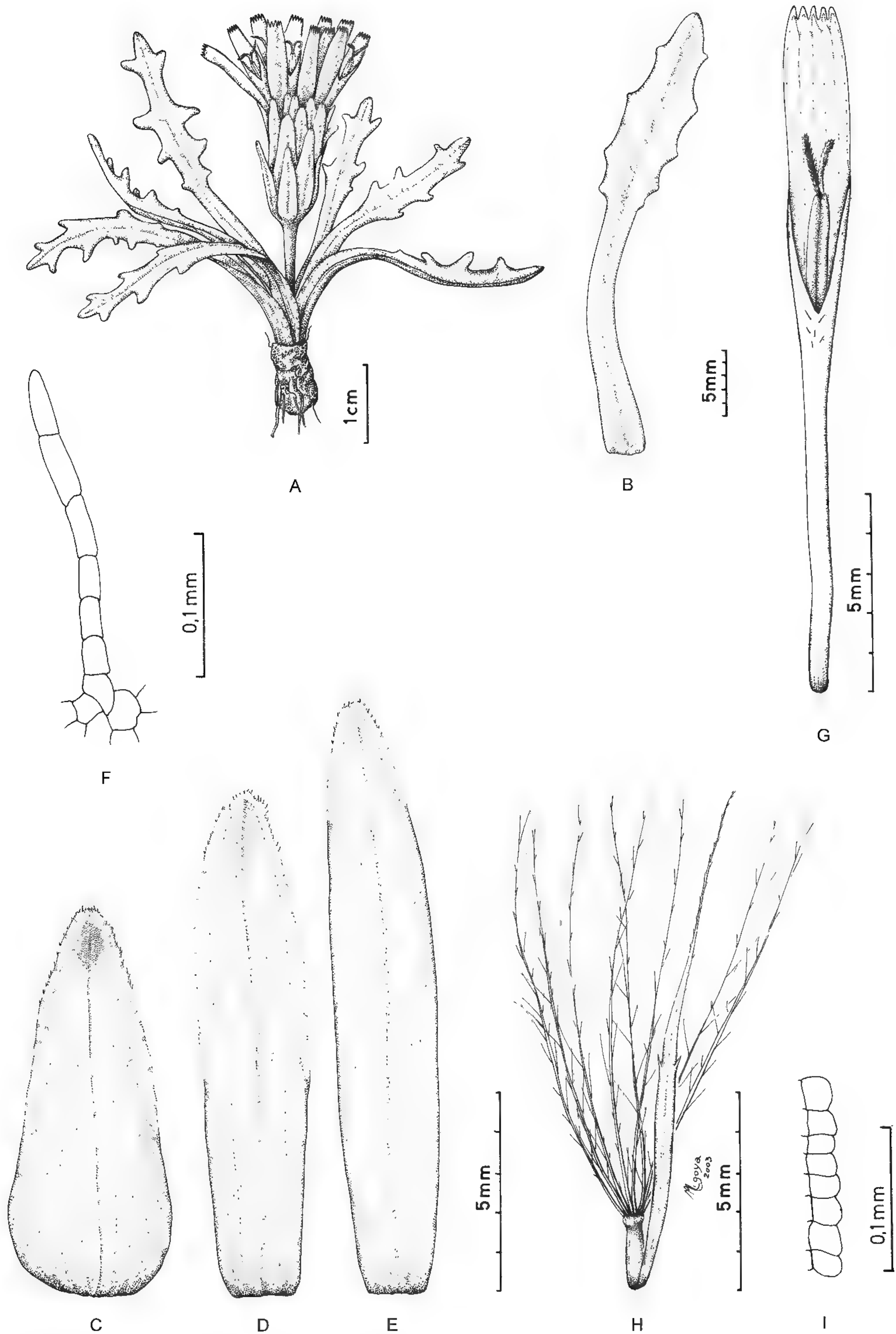

Figure 5. *Hypochaeris taraxacoides*. —A. Habit. —B. Leaf. —C–E. Phyllaries. —F. Trichomes (in cilia) on phyllaries. —G. Corolla with anthers and style. —H. Palea, cypselae, and pappus. —I. Smooth cypselar wall. From *Stuessy et al. 18074* (LP).

6 mm, setaceous phyllaries with yellow-green and purple trichomes, and outer and middle phyllaries that are divided at the apex (Fig. 3D). Despite these conspicuous morphological features, this form likewise seems to have no geographic integrity; we deem it not worthy of formal recognition. We have seen variation in capitula as represented in Figure 3B–D within a single population on Volcán Pichincha (*Stuessy et al. 18539*) in Ecuador. Schultz Bipontinus (1845: 120) also struggled with the morphological variation within this species (as *A. quitensis*, nom. illeg.). He recognized a set of unnamed “Formae” in the following manner: I, entire plant glabrous; IIa, heads large; IIb, heads half as small; IIIa, plants subacaulescent; IIIb, plants caulescent. This is a variable species. More populational sampling within its broad geographic range using morphometric and/or molecular analyses would be worthwhile.

Observations. *Hypochaeris sessiliflora* and *H. sonchoides* were published by Kunth (1818) in the same volume (even on the same page), and either could be selected for use (McNeill et al., 2006: Art. 11.5). The former is the much more widely used name, however, and therefore it has been retained.

Schultz Bipontinus (1845: 120) published the names *Achyrophorus quitensis* Sch. Bip., *Scorzonera quitensis* Humb., and *S. sessilis* Humb. under *Hypochaeris sessiliflora*. Because they were not accompanied by descriptions or specimens, they remain prosynonyms. *Hypochaeris sessiliflora* f. *caulescens* Hieron. (Bot. Jahrb. Syst. 28: 658. 1901) is another invalid name because it was published without description.

Schulz Bipontinus (1859: 52) also published *Achyrophorus albiflorus* Sch. Bip. and *A. humboldtii* Sch. Bip., but both are nom. illeg., being superfluous names of *A. quitensis* Sch. Bip., which itself is illegitimate, having been cited in synonymy of *Hypochaeris sessiliflora*. Bortiri (1997) lectotypified both *A. albiflorus* and *A. humboldtii*, but being illegitimate, this is unnecessary. *Hypochaeris sessiliflora* var. *albiflora* Hieron. (Bot. Jahrb. Syst. 28: 658. 1901), therefore, is also an illegitimate name.

Reiche (1905) may have had a confused concept of *Hypochaeris barbata*, as he cited it as occurring in northern Chile (Prov. [– Region] Tarapacá), where *H. sessiliflora* is not known to occur (Fig. 4A); he probably had material of *H. eremophila*, as he cited *Distoecha taraxacoides* Phil. in synonymy.

Representative specimens. BOLIVIA. **Cochabamba:** Tunari [probably Cerro Tunari], *Müsch 151* (p.p., SI). COLOMBIA. **Boyacá:** entre Gachoque y Toca, *Zuloaga & Landon 4136* (SI). **Caldas:** Nevado del Cocuy, alto valle de Las Lagunillas, *Cuatrecasas 1484* (US). **Cauca:** Cordillera Central, E slopes of páramo del Purace, around la laguna de

San Rafael, *Cuatrecasas & Willard 26299* (US). **Cundinamarca:** Páramo de Chisacá, *Soderstrom 1254* (NY). **Magdalena:** Sierra Nevada de Santa Marta, valley descending SW from Pico Reina and Ojeda, *Cuatrecasas & Romero Castaneda 24560* (US). **Nariño:** Pasto, volcán de El Galeras above Pasto, *Ewan 16324* (US); Pasto, Volcán Galeras, *Plowman 1955* (US); University of Nariño property, vic. Granja Botana, 3.5 km down rd. from entrance, ca. 7 km S of Pasto, *Leiteyn, Dumont & Buritica 4995* (NY). **Santander:** Páramo de Mogotocoro, near Vetas, *Killip & Smith 17641* (US); *Molina & Barkley 18 S.388* (US). ECUADOR. **Azuay:** Cuenca, Parroquia Baños, hacienda de Yanasacha, *Boecke & Jaramillo 2493* (US). **Azuay-Loja:** Nudo de Cordillera Occidental y Cordillera Oriental entre Oña y Rancho Ovejero, *Barclay & Juajibioy 8472* (US). **Carchi:** Julio Anrade-playón de San Francisco rd., La Palestina, *Boelke & Jaramillo 2348* (NY). **Chimborazo:** along the rd. to Riobamba, ca. 20 km SW of Riobamba, *King & Garvey 6968* (US). **Cotopaxi:** 5.5 km E of Pujilí, *Stuessy et al. 18549* (LP, WU). **Imbabura:** Cotacachi Canton, Res. Ecol. Cotacachi-Cayapas, laguna de Cuicocha, *Peñafiel et al. 382* (US). **Loja:** 12 km NW of Saraguro on loma Paredones, *Ellemann 91672* (US). **Napo:** Tena Cantón, Parque Nac. Llaganates, vía Salcedo-Tena, de laguna Chaloa Cocha desvío a Rayo Filo, *Vargas, Narváez & Orellana 2619* (NY, US). **Napo-Pastaza:** alrededores de Los Llanganati, entre Ainchilibí y Río Portrero, E de Romo Páramo, *Barclay & Juajibioy 9210* (US). **Pichincha:** 23 km E of Pifo, *Stuessy et al. 18540* (WU). **Tungurahua:** Patate Cantón, Parque Nac. Llanganates, laguna de Aucacocha-cerro Pan de Azúcar, *Vargas, Ronquillo & Granda 2887* (US). PERU. **Amazonas:** Chachapoyas, Quebrada Molino, 5 km below Chachapoyas, *Wurdack 761* (US). **Ancash:** Huaylas, distr. Pamparnas, path Karka to laguna Negra Huacanam, around the laguna itself, *Weigend 2000/616* (NY). **Celendín:** 17–24 km from Celendín, *Smith & Cabanillas 7328* (US). **Cuzco:** Cuzco, alrededores de las ruinas de Sacsahuamán, *Beck 8356* (LPB). **Junín:** Huancayo, *Killip & Smith 23369* (US). **Lima:** Río Blanco, *Killip & Smith 21680* (US). **Puno:** Cavasaya, hda. Sojela, *Vargas 21784* (LP). VENEZUELA. **Apure:** a lo largo del Río Talco (Oirá) y sus afluentes, en páramos entre Alto de Cruces y Tierra Negra, *Steyermark & G. C. K. & E. Dunsterville 101105* (NY). **Mérida:** Mérida, páramo at laguna de Mucubaji, near Apartaderos and San Rafael, 35 km NE of Mérida, *Maguire 39405* (NY).

2. *Hypochaeris taraxacoides* Ball, J. Linn. Soc., Bot. 22: 48. 1885. *Oreophila taraxacifolia* Meyen & Walp., Nov. Actorum Acad. Caes. Leop.-Carol. Nat. Cur. 19(suppl. 1): 291. 1843, non *Oreophila taraxacifolia* Loisel., 1827. TYPE: “Peruvia: in planitie circa Tacoram,” 14,000–17,000 ft., 1831, *F. J. F. Meyen s.n.* (holotype, B [presumed destroyed, Stafleu & Cowan, 1981]). Figure 5.

Hypochaeris stenocephala (A. Gray ex Wedd.) Kuntze var. *integrifolia* Kuntze, Revis. Gen. Pl. 3(2): 160. 1898. *Hypochaeris stenocephala* (A. Gray ex Wedd.) Kuntze var. *taraxacoides* (Meyen & Walp.) Kuntze, Revis. Gen. Pl. 3(2): 160. 1898. TYPE: Bolivia. Dept. Oruro: Oruro, 1892, *C. E. O. Kuntze s.n.* (holotype, NY!).

Herbs to 7 cm tall. Leaves lanceolate or oblong, 1.5–11 × 0.3–1.2 cm, pinnatifid to lobate, glabrous, at base attenuate. Capitula pedunculate to 40 mm;

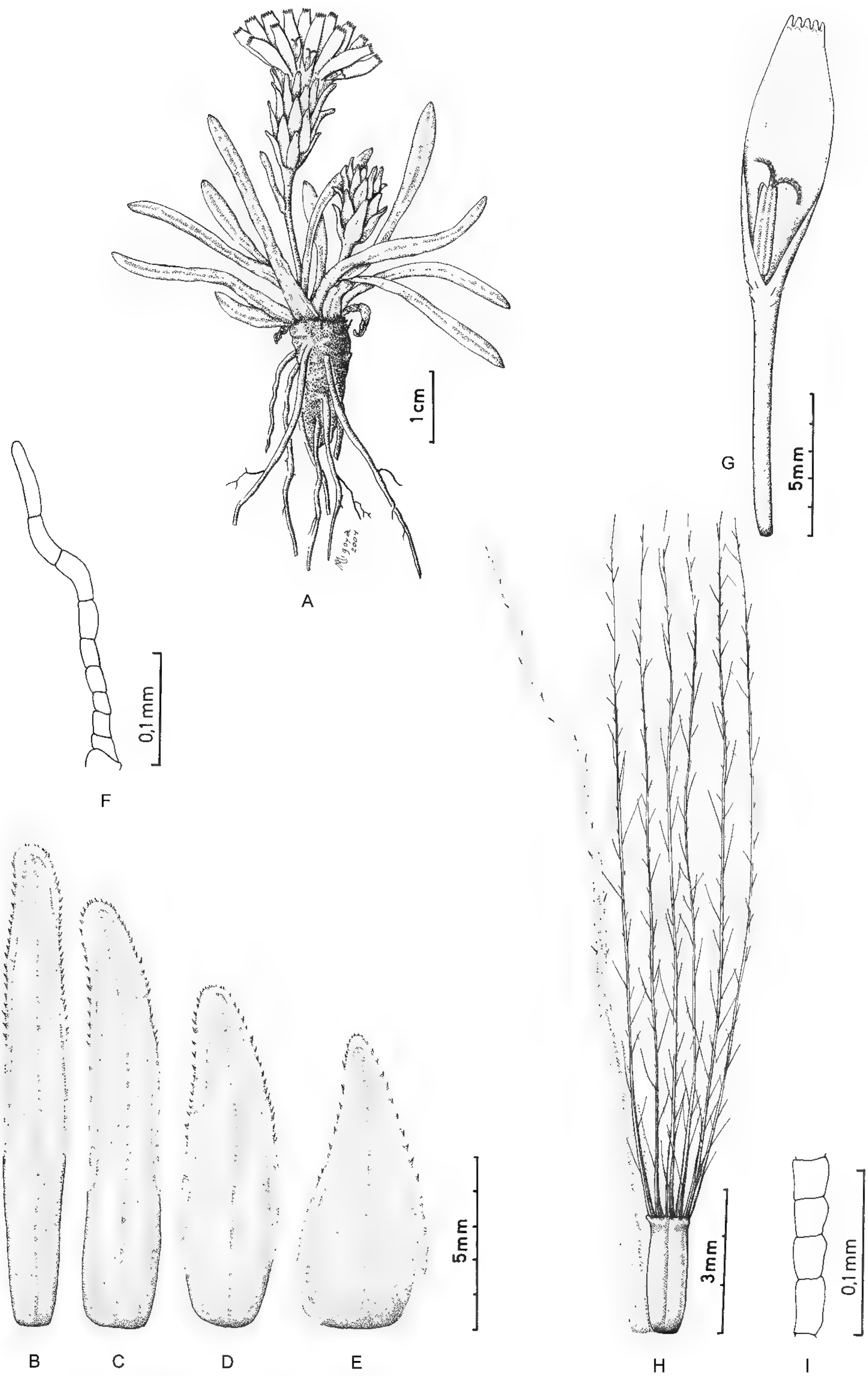

Figure 6. *Hypochaeris hohenackeri*. —A. Habit. —B–E. Phyllaries. —F. Cilia on phyllaries. —G. Corolla with anthers and style. —H. Palea, achene, and pappus. —I. Smooth cypselar wall. From *Lewis 35168* (LP).

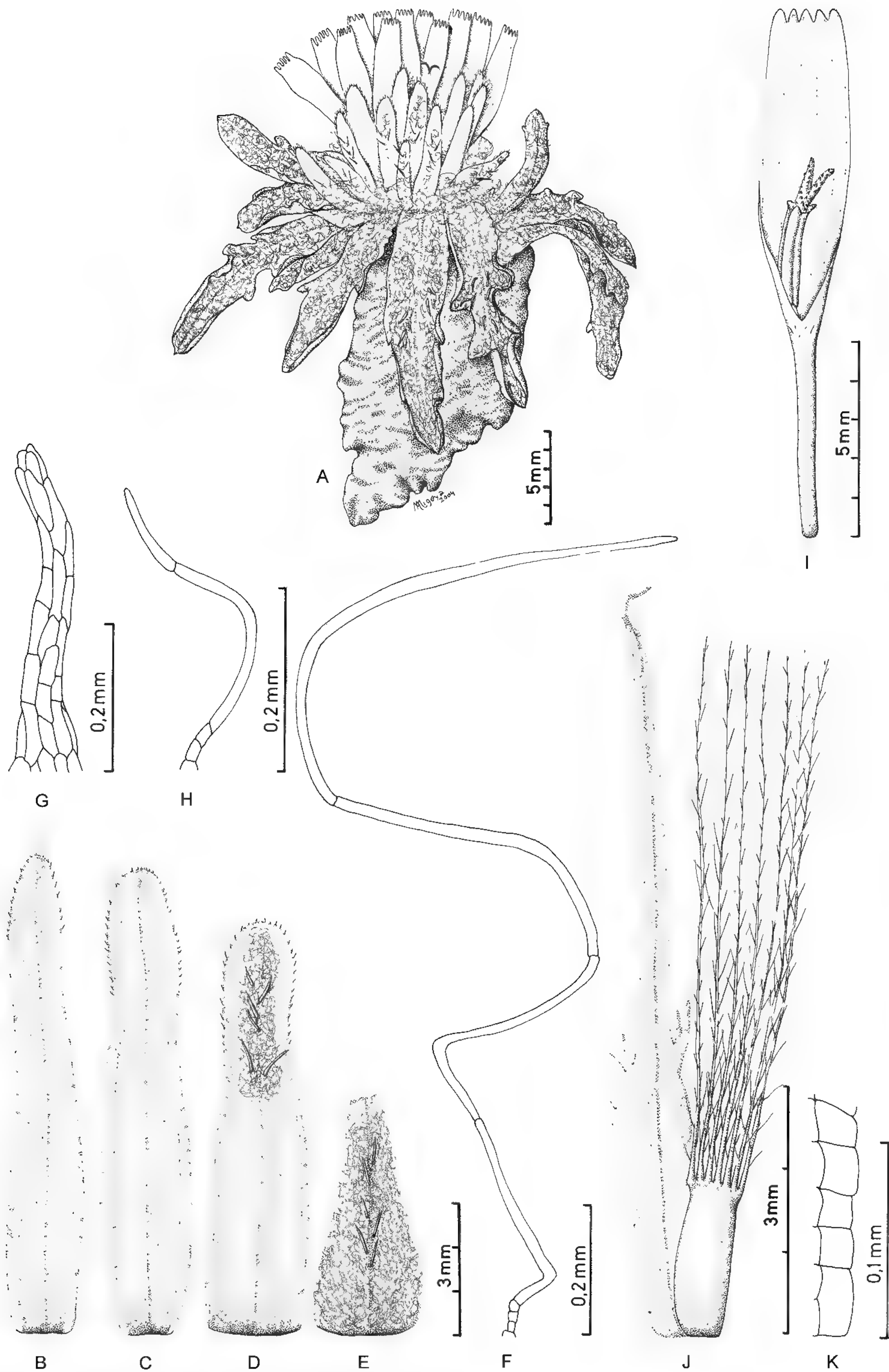

Figure 7. *Hypochaeris mucida*. —A. Habit. —B–E. Phyllaries. —F. Whip trichomes on phyllaries. —G. Shaggy trichomes on phyllaries. —H. Trichomes (in cilia) on phyllaries. —I. Corolla with anthers and style. —J. Palea, cypselae, and pappus. —K. Smooth cypselar wall. From *Ceballos et al.* 614 (SI).

involucre cylindrical, 14–23 × 5–10 mm; phyllaries 3- to 4-seriate, lanceolate, apex rounded, margin ciliate; outer phyllaries 8–11 × 2–3 mm; inner phyllaries 15–19 × 3–3.5 mm; paleae 12–18 mm; flowers ca. 30 per capitula. Corollas white (upper surface) to dark blue-black at tips of ligules underneath, 15–21 mm; tube 7–9 mm; ligule 8–12 mm; vascularization type 2; stamens 10–17 mm; anthers 4–5 mm; basal appendages type 3, ca. 1 mm; filaments 6–12 mm; antheropodium type 1; style 12–22 mm, with style branches 1.8–2 mm. Cypselae erostrate, 1.8–2 mm; wall smooth; pappus 12–17 mm. Chromosome number $2n = 8, 16$ (Parker, 1971; Weiss et al., 2003 [as *Hypochoeris stenocephala*]; Weiss-Schneeweiss et al., 2007, 2008).

Habitat and distribution. *Hypochoeris taraxacoides* inhabits bogs and seeps from Colombia to northern Chile and northwestern Argentina, 2640–5000 m (Fig. 4B, circle).

Phenology. *Hypochoeris taraxacoides* flowers throughout the year.

Common names. “Achicoria” (Argentina, *Haber 142*); “chicoria” (Peru, *Mexia 4191*); “diente de león” (Bolivia, *Schulte 9*); “flor de ciénaga” (Argentina, *Cabrera et al. 22484*); “lechero” (Argentina, *Haber 5*); “mula-siki” (Bolivia, *Wolstenholme 6*); “pilly” (Peru, *Mexia 4191*).

Morphological characters. *Hypochoeris taraxacoides* is readily distinguishable from other taxa by the combination of peduncular (rarely sessile) cylindrical heads, glabrous phyllaries (ciliate on margins) and leaves, and corollas white on the upper surface to dark blue-black at the tips of ligules underneath (abaxial surface), and being longer than the involucre.

Observations. Although no isotype has been located, the detailed description and locality combine to leave no doubt as to the biologic affinity of this name. The locality of plains near “Tacoram” presumably refers either to the town of Tacora and/or Volcán Tacora, both of which are now within the boundaries of Chile, Region I, Parinacota Province (just across the border from Peru), Tacna Department. At the time of collection and for another half century, this region was within Peru (e.g., Enoch, 1908: cf. map). Ratzeburg (1843: xviii) tells us that Meyen went up from Arica, Chile, toward Lake Titicaca, and Tacora is on this route. This species is known from this general region (Fig. 4B, circle).

In publishing *Achyrophorus taraxacoides* Walp. (Repert. Bot. Syst. 6: 336. 1846, nom. illeg.) [non *A. taraxacoides* (D. Don) Steud. (Steudel, 1841: 226)], Walpers (1846) purported to make a new combination based on *Oreophila taraxacoides* Meyen & Walp., but

gave reference to the place of publication of *O. taraxacifolia* Meyen & Walp. Whether or not this incorrect epithet used in the combination should be treated as an error to be corrected to “*A. taraxacifolia*” or considered deliberate in view of the existence of *A. taraxacifolia* Moench (Moench, 1802) is unimportant because, in either case, the name is illegitimate, with Steudel having validly published the name *A. taraxacoides* five years earlier. *Hypochoeris taraxacoides* (Walp.) Benth. & Hook. f. (Gen. Pl. 2: 519. 1873) has also been used in some reports (e.g., Bortiri, 1999, as synonym) and in much herbarium material, but this also uses the incorrect epithet in combination. More importantly, Bentham and Hooker (1873: 519) did not actually make the combination. They only listed “...in *Achyrophoro taraxacoides*, Walp.” under *Hypochoeris* (as “*Hypochoeris*”), a particular technique in this work that is specifically disallowed as a new combination in Article 33.1 of the *International Code of Botanical Nomenclature* (and exemplified in McNeill et al., 2006: Art. 33, Ex. 2). The first publication of a legitimate name for the species in *Hypochoeris* followed shortly thereafter: *H. taraxacoides* Ball (J. Linn. Soc., Bot. 22: 48. 1885). It is curious that Walpers, one of the two original authors, cited the original epithet *taraxacifolia* incorrectly when transferring it into *Achyrophorus*, and in this was followed by Bentham and Hooker and Ball under *Hypochoeris*. They may have been aware of the earlier competing name, *H. taraxacifolia* Moench (Suppl. Meth. 224. 1802), now referable to *Crepis albida* Vill. (Babcock, 1947: 310) or to the earlier *O. taraxacoides* D. Don, which does not belong to the *H. sessiliflora* complex, but there is no evidence of this. It is fortunate for maintaining stability of usage that *H. taraxacoides* Ball can be treated as a new name in 1885, for a new combination based on the epithet that was actually used would have resulted in the illegitimate *H. taraxacifolia* (Meyen & Walp.) Ball, a later homonym of *H. taraxacifolia* Moench (Moench, 1802). An earlier *H. taraxacoides* Pourr. ex Steud. (Nomencl. Bot. [Steudel], ed. 1, 422, 618. 1821) also exists, but appears as a synonym of *Picridium albidum* DC. (– *Crepis albida* Vill., Babcock, 1947: 310); the name is not validly published and so creates no competing difficulty.

Achyrophorus stenocephalus A. Gray ex Wedd. is an invalid name because it was listed by Weddell (1857) as synonym under *Achyrophorus taraxacoides* (Meyen & Walp.) Walp. *Hypochoeris stenocephala* (A. Gray ex Wedd.) Kuntze [Kuntze, 1898]), therefore, is an illegitimate combination.

The characters used by Kuntze (1898: 160) to differentiate *Hypochoeris stenocephala* var. *integrifolia* from variety *taraxacoides* are leaf margins entire or

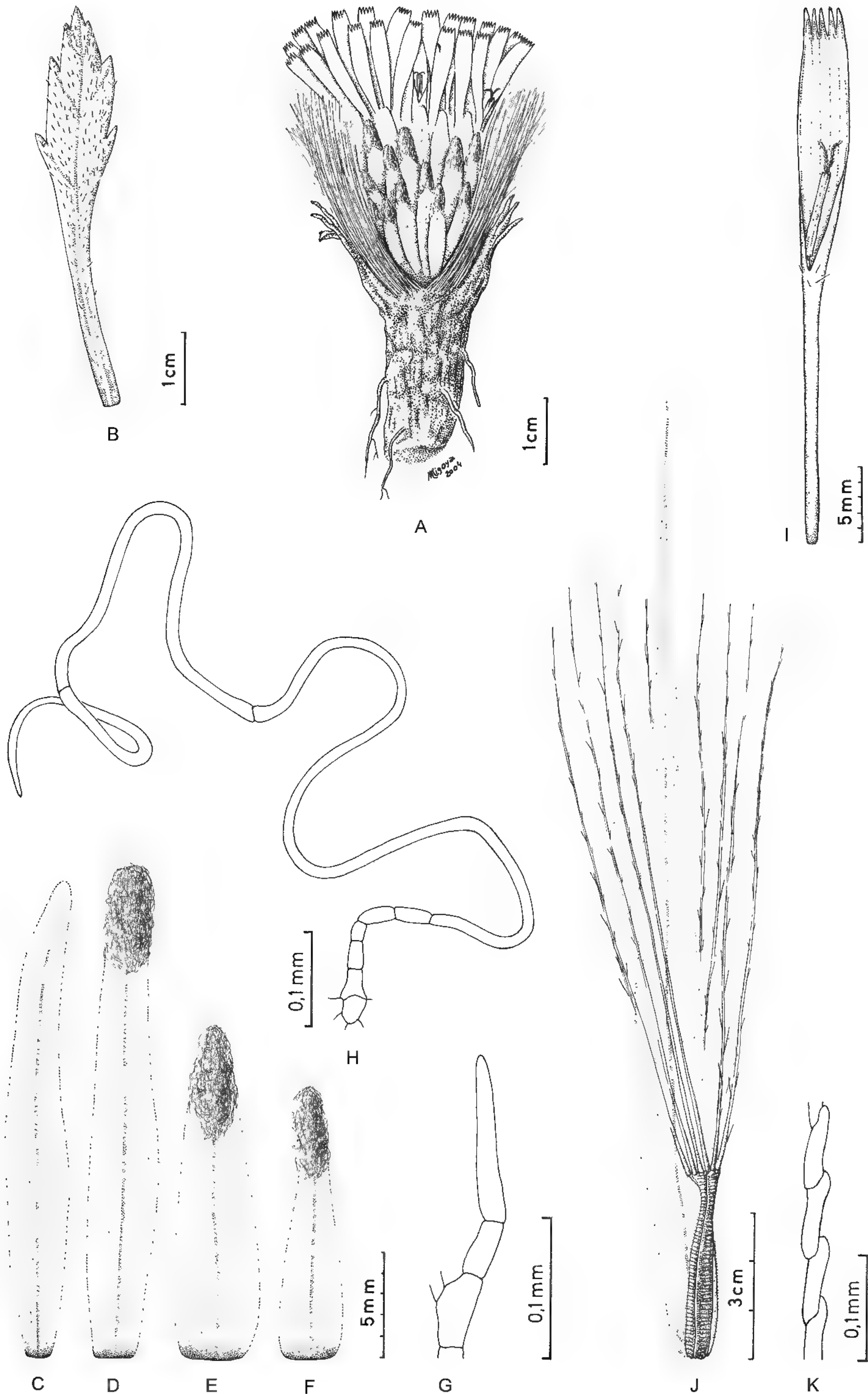

Figure 8. *Hypochaeris eriolaena*. —A. Habit. —B. Leaf. —C–F. Phyllaries. —G. Trichomes (in cilia) on phyllaries. —H. Whip trichomes on phyllaries. —I. Corolla with anthers and style. —J. Palea, cypselae, and pappus. —K. Smooth cypselar wall. From Smith & Buddensiek 11133 (LPB).

denticulate versus runcinate, respectively, which were essentially validating the listed, but not named, varieties in *Achyrophorus taraxacoides* (Meyen & Walp.) Walp. by Weddell (1857). This variable feature (leaf margin) is insufficient for varietal recognition.

The name *Hypochaeris taraxacoides* (Meyen & Walp.) Ball var. *lanuginosa* Herzog is a nomen nudum because it was only mentioned in a list of Bolivian plants published by Herzog (1923: 228).

Representative specimens. ARGENTINA. **Catamarca:** Antofagasta de la Sierra Hoyada de Antofagasta, *Haber* 5 (SI). **Jujuy:** Capital, refugio del nevado de Chañi, *Fabris, Cano & Tello* 4035 (LP); Cochino, Abra Pampa, cerro Huancar, *Cabrera et al.* 15256 (LP); Humahuaca, 31.4 km W of Humahuaca on gravel rd. to El Aguilar, *Stuessy, Urtubey & Tremetsberger* 18089 (LP, WU); Humahuaca, 0.8 km NW of Chiapi Rodeo on dirt rd. to Iruya, *Stuessy, Urtubey & Tremetsberger* 18074 (LP, WU); 4.7 km NW of Chiapi Rodeo on dirt rd. to Iruya, *Stuessy, Urtubey & Tremetsberger* 18075 (LP, WU); Iturbe, *Meyer, Cuezco & Legname* 21040 (LP); Rinconada, Mina Pirquitas, *Schwabe, Ancibor & Vizinis* 641, 818, 819 (LP); Tilcara, lecho de Río Grande cerca de Huacalera, *Werner* 820 (LP); Tumbaya, camino de El Angosto al Chañi, encrucijada Río Chañi, *Cabrera et al.* 22484 (LP); Valle Grande, Caspalá, *Burkart & Troncoso* 11822 (SI); Yavi, Quebrada de Toquero, *A. L. & S. M. Cabrera, Malacalza & von Schmid* 17656 (LP); Lecho, 1–2 km S RP 5, Km 13, 4–5 km SW de Yavi, *Tolaba, Acuña, Arapa, Gutiérrez, Quiroga, Ragno, Ramallo & Da Silva* 1539 (MCNS). **La Rioja:** Famatina, Sierra de Famatina, *Rohweder T-12* (LP). **Salta:** Los Andes, Vega de Tocomar, *Cabrera et al.* 22531 (LP); Poma, Quebrada entre Muñaño y Tastil, *Cabrera* 8993 (LP); San Antonio de Los Cobres, San Antonio de Los Cobres, *Krapovickas* 3155 (K, SI); Santa Victoria, 43.7 km from Santa Victoria on rd. to La Quiaca, *Hawkes, Hjerting & Rahn* 3900 (K, LP). **Tucumán:** Tafí, Cerro Muñoz, La Banda, *Fabris* 1520 (LP). BOLIVIA. **Cochabamba:** Chapare, Quebrada de Colomi, *Balls B-6253* (K, UC); Quillacollo, 63 km de Cochabamba en dirección al poblado de Cami, alrededores del cerro Pytuljata, *Lieberman* 2343 (LPB, US); Tapacarí, Qachi uñkata, cerca del Río Chankha, 3 km al E de Japo K'asa, *Pestalozzi* 284 (LPB). **La Paz:** Aroma, Kanton Callamarca, 6 km nördlich Calamarca an der Straße La Paz-Oruro, *Krach* 7492 (SI); Camacho, Puerto Acosta, 10 km hacia La Paz, al borde del Río Huaycho, cerca del Lago Titicaca, *Beck* 7712 (SI); Fray Tamay, Pelechuco, *Krach* 9391 (SI); Ingavi, low ridge along the main rd. from La Paz to Viacha, ca. 8 km NE of Viacha, *Solomon & Nee* 14233 (LPB, NY); La Paz, Palca, zona basal del Illimani, *Ceballos et al.* 548 (SI); Pacajes, La Paz entre Corocoro y Topohoco, *Ceballos et al.* 164 (SI); Los Andes, Kanton Peñas, Straße zur Mina Fabulosa, Km 6.5 von der Abzweigung von der Straße La Paz-Huarina, *Krach* 8435 (SI); Larecaja, viciniis Sorata, inter Ancohuma et Turilaque, *Mandon* 276 (BM, K, W); Murillo, 4.6 km S jct. rd. to Chacaltaya on rd. from Milluni to El Alto (La Paz), *Solomon* 13177 (LPB); Nor Yungas, Canton Pocollo, La Cumbre, *Krach* 8672 (SI); Omasuyos, Cantón Huarina, comunidad de Moco-Moco, *Loza de la Cruz* 72 (LPB); Tamayo, Ulla-Ulla, estribaciones de la cordillera de Apolobamba, *Menhofer* 1036 (LPB); Saavedra, bei Curva großes Moor oberhalb der Endnoränen oberhalb Canizaya, *Freuler* 4384 (SI); Tamayo, Ulla-Ulla, Okaria, *Menhofer* 1600 (LPB). **Oruro:** Sajama, Cantón Lagunas, puna y

vegetación alto andina, *Loza de la Cruz* 254 (LPB). **Potosí:** Frías, cerro Khare-Khare detrás de la ciudad, *Schulte* 9 (LPB). **Tarija:** José María Avilez, Pampa Tajzara, Arenales, *Beck & Paniagua* 27086 (LPB). COLOMBIA. **Boyacá:** Cordillera Oriental Páramo de Huma, entre Belén y Susacón, *Barclay & Juajibioy* 7642 (US). PERU. **Ancash:** along Perú hwy. 105 to Chavin de Huantas, ca. 26 km E of Catac, *King & Collins* 9064 (US). **Arequipa:** Arequipa, just SW of Puno border, Paso del Cóndor, *Iltis & Ugent* 1489 (UC). **Ayacucho:** ca. 10 km N of Mataral, on trail to Ayacucho, *West* 3663 (UC). **Cuzco:** Urubamba, *Zamalloa Díaz* 78 (LP); Chanchis, La Raya pass 1 km WNW of La Raya on Cuzco rd., *Iltis & Ugent* 1256 (US); Chumbivilcas, 15 km de Sto. Tomás a Yairi, *Hoogte & Roessch* 2534 (NY); Paucartambo, Paucartambo, Accanaco, *Balls B6711* (K). **Huancavelica:** Huancavelica, Ojapampa, entre Laria y Tambopata, a 25 km de Conaica, *Tovar* 850 (LP [2]); Tayacaja, quebradas westward from Huancavelica, *Stork & Horton* 10838 (UC). **Huancayo:** Huancayo, 30 km N of Huancayo, *Blair* 636 (K). **Huánuco:** Huánuco, 15 mi. NE of Huánuco, *Macbride & Featherstone* 2167 (US). **Junín:** Concepción, Km 112, rd. Concepción–Satipo, *Saunders* 1106 (K, UC); Junín, Capillacocha, a 20 km E of Carhuamayo, *Tovar* 390, 393 (LP); Llanos de Junín, 76°00'W, 11°10'S, *Smith et al.* 5652 (NY); Tarma, lago Junín, 13 km N of Junín, *Hutchison, Wright & Straw* 5892 (UC); Yauli, Jaranacu, cerca de Chacalpa, *Ochoa* 264 (US). **La Libertad:** Bolívar, laguna de Loa Ichus Nevado, Cajamarguilla, *López & Sagástegui* 3223 (LP); Pataz, Huancaspata–Tajabamba, *López & Sagástegui* 8245 (LP); Santiago de Chuco, Quesquenda, Jalca Quiruvilca, *López & Sagástegui* 2888 (LP). **Lima:** Canta, Carhuapampa (camino a Canta–Lachaqui), *Mezar* 162 (LP); Yauyos, Huancracha arriba de Tupe, *Cerrate & Tovar* 1174 (LP). **Puno:** Patanca, *Fiebrig* 3188 (BM, K).

3. *Hypochaeris hohenackeri* (Sch. Bip.) Domke, Notizbl. Bot. Gart. Berlin-Dahlem 13: 251. 1936. Basionym: *Achyrophorus hohenackeri* Sch. Bip., Bonplandia 4: 54. 1856. TYPE: Peru. “Tobina in Cordill. sum. jug. [summit ridge],” July 1854, *W. Lechler* 2111a (holotype, P!). Figure 6.

Hypochaeris parvifolia J. Kost., Blumea 5(3): 661, fig. 3c. 1945. TYPE: Bolivia. Dept. La Paz: “Rosettenpolster auf Alpenwiesen im Tcacota-Thal” [most probably Teacota River valley, 16°43'S, 67°25'W, Division of Geography, 1955; protologue gives “Tcacota-Thal,” but label “Teacota-Thal”], 4300 m, Oct. 1911, *T. Herzog* 2425c (holotype, L, digital image!).

Herbs to 4 cm tall. Leaves oblong, 20–30 × 2–3 mm, base attenuate, margin entire or slightly dentate, glabrous. Capitula pedunculate to 20 mm (rarely sessile). Involucre campanulate, 11–15 × 6–8 mm; phyllaries 4- to 6-seriate, lanceolate, apex acute or slightly rounded, margin ciliate; outer phyllaries 8–9 × 2.5–3 mm; inner phyllaries 13–15 × ca. 2 mm; paleae 11–15 mm; florets ca. 15 per capitula. Corollas yellow, rarely pink (*Smith & Cabanillas* 7212), 10–20 × 3–8 mm; ligule 7–12 mm; vascularization type 1; stamens 11.5–20.5 mm; anthers 8–12 mm; basal appendages type 1 or 2, 0.50–0.75 mm; filaments 3.5–8.5 mm; antheropodium type 1 or 2; style 10–12 mm; style branches

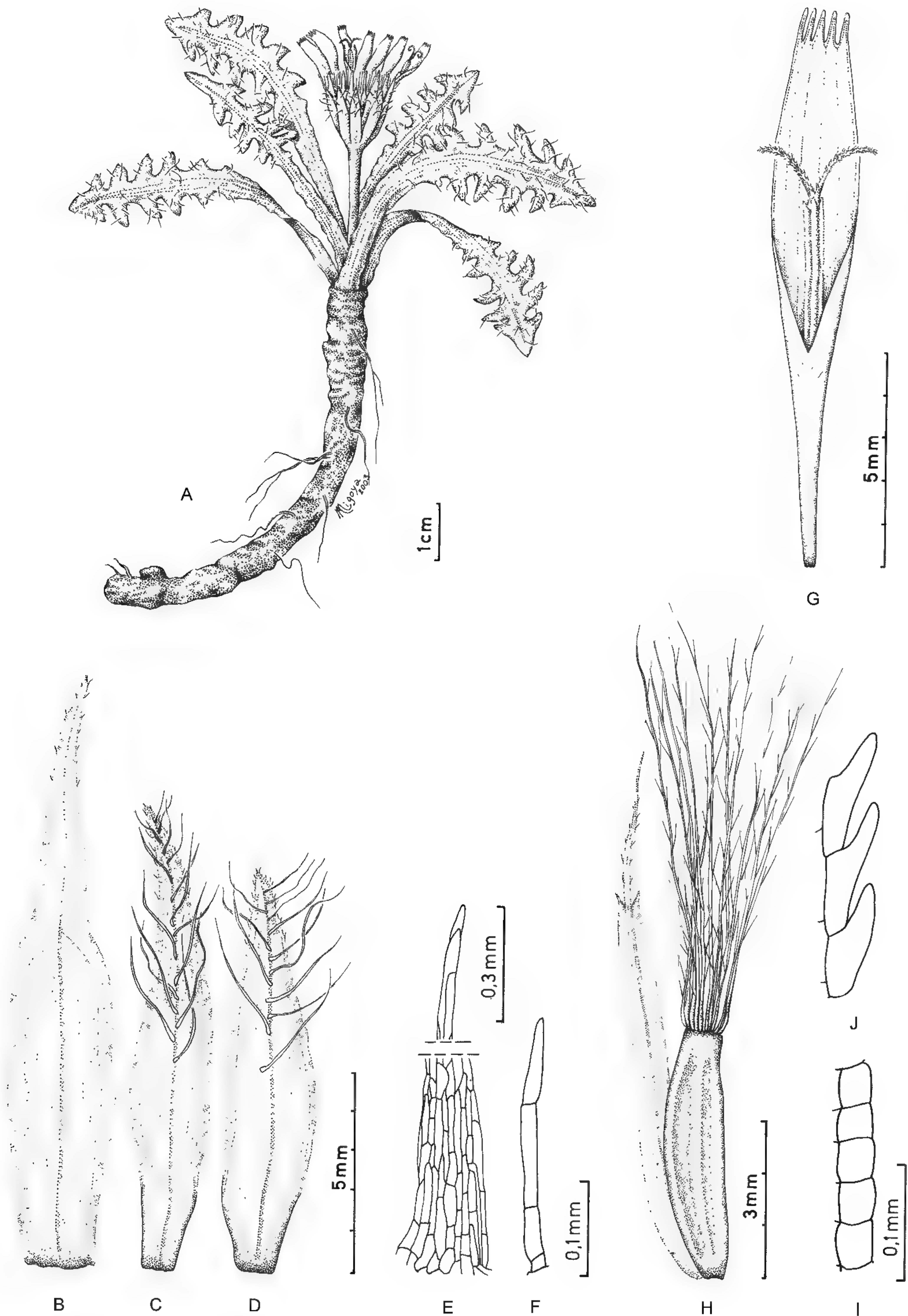

Figure 9. *Hypochaeris echegarayi*. —A. Habit. —B–D. Phyllaries. —E. Shaggy trichomes on phyllaries. —F. Trichomes (in cilia) on phyllaries. —G. Corolla with anthers and style. —H. Palea, achene, and pappus. —I. Smooth cypselar wall. —J. Scaly cypselar wall. A–H, J from Valenzuela 998 (LPB); I from Hunziker & Caso 6039 (LP).

1.5–2.5 mm. Cypselae erostrate, 2–2.5 mm; wall smooth; pappus 9.5–15 mm. Chromosome number unknown.

Habitat and distribution. *Hypochaeris hohenackeri* occurs from Peru to Bolivia, 3200–4500 m, in humid grasslands, mountain pastures, riverbanks, and bogs associated with *Juncus* L. and *Stipa* L. (Fig. 4B, squares).

Phenology. *Hypochaeris hohenackeri* flowers from January to September.

Morphological characters. *Hypochaeris hohenackeri* is characterized by oblong, sometimes dentate, leaves, a pedunculate head (rarely sessile), and dark, glabrous phyllaries that are acute or rounded at the apex.

Observations. *Achyrophorus hohenackeri* ["*Hohenackeri*"] was published earlier by Schultz Bipontinus (1855: 236) as a nomen nudum. Although without description, he did cite a specimen (*W. Lechler 2111a*), which was later taken by him (1856: 54) as the original specimen to accompany his valid description (1856: 54) in the same journal. *Hypochaeris hohenackeri* Herzog (Herzog, 1923) is an illegitimate name because no basionym was provided.

Although the type specimen of *Hypochaeris parviflora* J. Kost. is small, there is no doubt of the affinity of this name; the original description is also accompanied by a clear illustration that shows the diagnostic characters of this species.

Representative specimens. BOLIVIA. **Cochabamba:** Arani, near the summit of the pass through the cordillera de Cochabamba, *Eyerdam 24839* (UC). **La Paz:** Inquisivi, along the trail betw. Pongo Chico and laguna Naranjani, ca. 3 km W of Quime, *Lewis 35168* (LPB, NY); W slope of cerro Kharrata SSE, Camillaya, *Müller & Heinrichs 6428* (LPB); 1 km NE of Mina Argentina and 10 km S of Coquetanga, *Lewis 38124* (LPB); Saavedra, el camino de Charazani a Hayrapata, *Menhofer X-1832* (LPB, SI). PERU. **Amazonas:** Chachapoyas, Chachapoyas–Celendín rd., cerro Calla-Calla, *Smith & Cabanillas 7212* (US); cerro de Calla-Calla, betw. Leimebamba–Balsas rd. pass and the camino de herradura, *Wurdack 1225* (LP). **Huancavelica:** Huancavelica, 4 km from Conayca, *Tovar 222* (LP).

4. *Hypochaeris mucida* Domke, Notizbl. Bot. Gart. Berlin-Dahlem 13: 250. 1936. TYPE: Bolivia. La Paz: "Mittlere Anden: Südlich des Titicaca-Sees über Ancoraime," 13,500 ft., 12 Feb. 1903, *A. W. Hill 299* (lectotype, designated here, K!). Figure 7.

Hypochaeris mucida Domke var. *integrifolia* Cuatrec., Proc. Biol. Soc. Wash. 77: 156. 1964. TYPE: Peru. Puno: WSW of Checayani, NE of Azangaro, puno, 4150 m, 29 Mar. 1957, *H. Ellenberg 495* (holotype, U not seen; isotype, US not seen, US photo LP!).

Herbs 1–1.5 cm tall. Leaves oblong, 8–20 × 1.5–4 mm, slightly toothed or pinnatifid, adaxial sur-

face sericeous with whip and some shaggy trichomes, abaxial surface with whip trichomes, petiole sericeous. Capitula sessile. Involucre campanulate, 8–12 × 9–10 mm; phyllaries 3- to 4-seriate; outer phyllaries lanceolate, to 12 mm, lanuginous with shaggy trichomes; inner phyllaries with the same indument or glabrous, margin ciliate. Paleae 9–11 mm; florets ca. 12. Corolla 9.5–11.5 mm, color unknown; tube 3.5–5 mm; ligule 6–6.5 mm; vascularization type 1; stamens 9–10.2 mm, anthers 4–4.2 mm; basal appendages type 1, 0.8–1 mm; filaments 4.5–6 mm; antheropodium type 1; style 8–10.5 mm, with branches 2–3 mm. Cypselae 5-ribbed, unbeaked, 2–3 mm; wall smooth; pappus ca. 8 mm. Chromosome number unknown.

Habitat and distribution. *Hypochaeris mucida* is known from Peru (Puno) and Bolivia (La Paz). It inhabits the Andean steppe at 4150–4700 m, associated with *Pycnophyllum* (Caryophyllaceae) (Fig. 4B, triangles).

Phenology. *Hypochaeris mucida* flowers from February to April.

Morphological characters. *Hypochaeris mucida* is the smallest species of *Hypochaeris*, growing to only 1.5 cm tall. The adaxial surfaces of the leaves and phyllaries are tomentose (with whip and some shaggy trichomes), giving it a distinctive appearance.

Observations. Cuatrecasas (1964) considered *Hypochaeris mucida* var. *integrifolia* to be unique in having leaves entire to sinuate, but this admittedly extreme leaf shape is sporadic and shows no geographic coherence. *Hypochaeris mucida* var. *integrifolia* is not recognized.

The holotype deposited at the Berlin herbarium was destroyed during World War II; the isotype specimen at K is here designated as the lectotype.

Specimens examined. BOLIVIA. **La Paz:** Camacho, Carabuco, Mina Matilde, *Ceballos et al. 614* (SI); Tamayo, Ulla-Ulla, estribaciones de la cordillera de Apolobamba, *Menhofer X-2197* (LPB). PERU. **Puno:** ENE of Checayani, *Ellenberg 638* (US, photo LP).

5. *Hypochaeris eriolaena* (Sch. Bip.) Reiche, Anales Univ. Chile 116: 589. 1905. Basionym: *Achyrophorus eriolaenus* Sch. Bip., Bonplandia 4: 54. 1856. TYPE: Peru. Puno: "Cordiller. pascuis sterilibus pr. Azangaro," June 1854, *W. Lechler 1754* (lectotype, designated by Bortiri [1997: 228], P!; isotypes, K!, P!). Figure 8.

Achyrophorus cryptocephalus Sch. Bip., Bonplandia 4: 54. 1856. *Hypochaeris cryptocephala* (Sch. Bip.) Domke, Notizbl. Bot. Gart. Berlin-Dahlem 13: 251. 1936, as "*cryptocephalus*." TYPE: Peru. Puno: "provincia Carabaya in cacumine Cordill. Agapata [Ayapata]," June

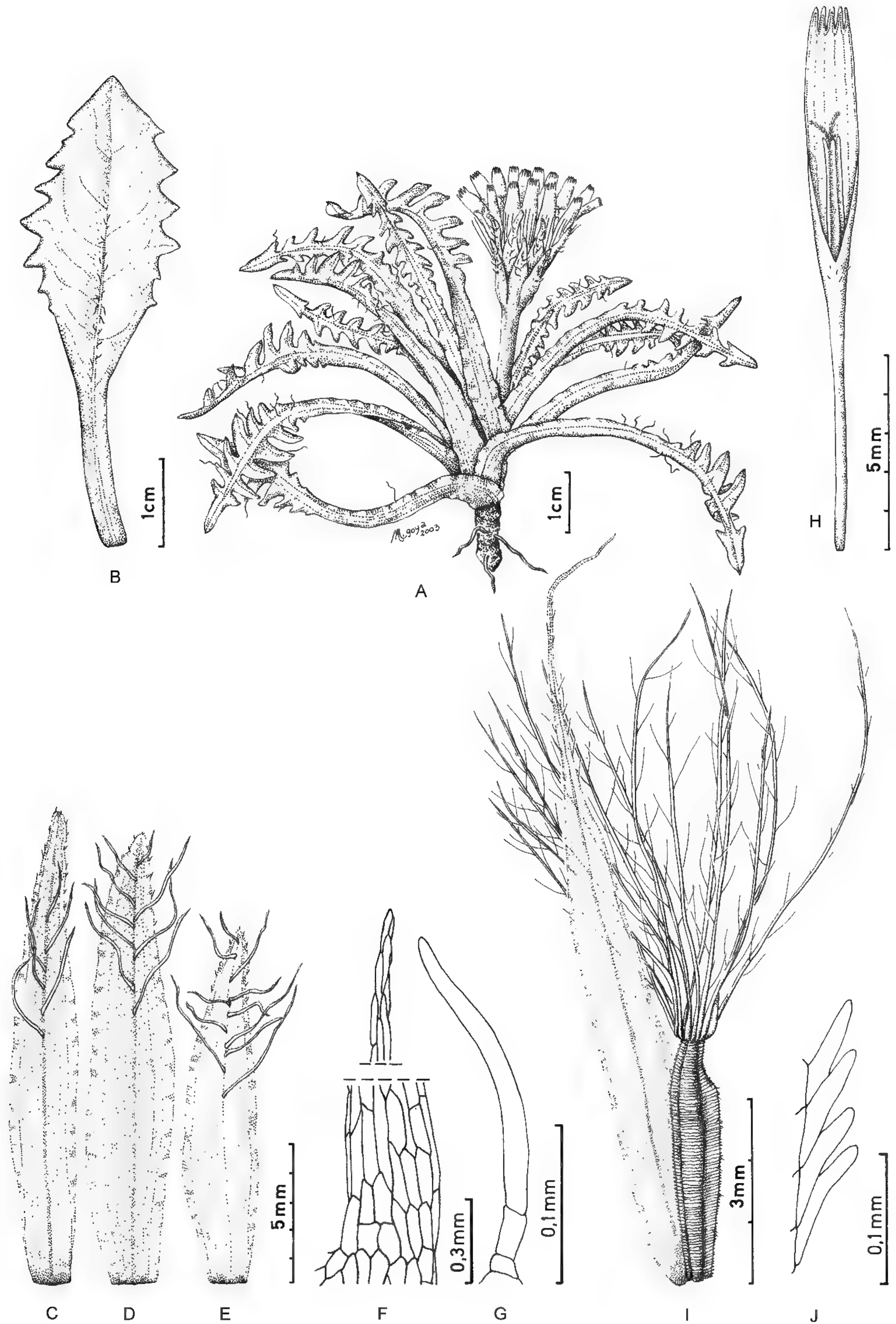

Figure 10. *Hypochaeris eremophila*. —A. Habit. —B. Leaf. —C–E. Phyllaries. —F. Shaggy trichomes on phyllaries. —G. Trichomes (in cilia) on phyllaries. —H. Corolla with anthers and style. —I. Palea, cypselae, and pappus. —J. Scaly cypselar wall. A, C–J from *Stuessy et al.* 18064 (LP); B from *Fabris* 1369 (LP).

1854, *W. Lechler 1963* (lectotype, designated here, P!; isotypes, P!, W!).

Hypochoeris spinneri Beauverd, Bull. Soc. Bot. Genève, ser. 2, 14: 177. f. XIII. 1922 [1923]. TYPE: Peru. Huancavelica: Huancavelica, above Huancavelica "in pascuis petrosis," 4700 m, 1915, *E. Godet 38* (holotype, presumably NEU, not located).

Herbs to 5 cm tall. Leaves lanceolate or oblongate, 25–70 × 5–16 mm, base attenuate in a broad petiole, margin toothed or entire, glabrous to sericeous (whip trichomes, to 35 mm) or with shaggy trichomes. Capitula sessile. Involucre campanulate or hemispheric, 10–30 × 15–25 mm; phyllaries 4- to 5-seriate; outer phyllaries ovate or lanceolate, lanuginous (with whip trichomes), 5–12 × 2–3 mm; inner phyllaries lanceolate to linear, 12–21 × 1.5–2.5 mm, lanuginous to glabrous, ciliate; paleae 15–28 mm; florets numerous. Corollas white or yellow to golden-yellow, 18–38 mm; tube 8–18 mm; ligule 10–20 mm; vascularization type 2; stamens 11–22 mm; anthers 3–7 mm; basal appendages type 1 or 2, 0.7–1 mm; filaments 8–15 mm; antheropodium type 1 or 2; style 15–26 mm, with branches 1.5–3 mm. Cypselae 5-ribbed, transversely wrinkled, erostrate or slightly narrower at the apex, 1.5–4 mm; wall scaly; pappus 11–29 mm. Chromosome number unknown.

Habitat and distribution. *Hypochoeris eriolaena* occurs in Peru and Bolivia in dry, stony Andean ridges, with scattered grass and limestone outcrops, 2200–5100 m (Fig. 4C, squares).

Phenology. *Hypochoeris eriolaena* flowers from May to November.

Common names. "Cebollana" (Peru, *Angulo & López 1358*); "qachi tika" (Bolivia, *Pestalozzi 606*).

Morphological characters. *Hypochoeris eriolaena* is clearly distinguishable from other members of the *H. sessiliflora* complex by long sericeous trichomes on broad petioles plus lanuginous phyllaries. This species often has no developed leaves when the capitulum opens.

Observations. Schultz Bipontius (1859) in his revision of *Hypochoeris* (as *Achyrophorus*) distinguished *H. cryptocephala* from *H. eriolaena* by abaxially sericeous phyllaries in the former and niveous-tomentose phyllaries in the latter. Indument on phyllaries is a variable character in *H. eriolaena*, which can have phyllaries with both lanuginous (with long whip trichomes) and matted indument; furthermore, sometimes phyllaries in the inner series are glabrous. Because of this range of variation, we treat *H. cryptocephala* as conspecific with *H. eriolaena*.

Despite no type having been located of *Hypochoeris spinneri*, the figure associated with the protologue

leaves little doubt of the biological placement of this name.

Hypochoeris eriolaena var. *hispida* Herzog (Herzog, 1923) is a nomen nudum appearing only in a list of plants from Bolivia.

Representative specimens. BOLIVIA. **Cochabamba:** Arque, cerca camino a Tacopaya, *Ibisch & Rojas 439* (LPB); Tapacari, Jacha Rancho, comunidad Japo (Km 125 de la carretera Cbba.–Oruro), *Pestalozzi 606* (LPB). **La Paz:** Achachicala (cumbre), subiendo 3 km de la mina Kaluyo hacia la cumbre, *Beck 11914* (LPB, SI). CHILE. **Tarapacá:** Cosapilla, Limani, *Wevi 129* (LP). PERU. **Ancash:** Huaráz-Marcará, *Velarde Núñez 3225* (LP); Yungay, Yungay-Llanganuco, *López, Sagástegui & Aldave 7421* (LP). **Cajamarca:** Cajamarca, Majada Pampa, Jalca Alta, *Becker & Terrones 1433* (US). **Contumazá:** Shanón (arriba de Contumazá), *Sagástegui, Alvitez & Mostacero 9006* (SI). **Cuzco:** Canchis, en dirección al cementerio (parte alta), *Vargas 11355* (US); Espinar, alrededores de Yauri, *Vargas 11350* (p.p.) (US). **Huancavelica:** Huancavelica, Huaytanayoc-Tansiri, Conayca, *Tovar 2512* (LP). **Junín:** Pampa de Junín, cerro de Pasco and Junín, *Canne & Schunke 232* (US). **La Libertad:** Otuzco, carretera a Shoreyo, ladera rocosa, *Angulo & López 1358* (LP); Sánchez Carrión, summit above Aricapampa on rd. to Huamachuco, *Hutchison, Wright & Straw 6267* (K, US); Santiago de Chuco, Huillillas, N of Cachicadan, *Stork & Horton 10000* (UC). **Lima:** Canta, La Viuda (cerca de Cullhuay), *Meza 207* (LP). **Puno:** Puno, San Antonio de Esquilante, *Stafford 865* (K); Juliaca, Hillside Capachica, Península Lake Titicaca, *Tutin 1209, 1210* (BM).

6. *Hypochoeris meyeniana* (Walp.) Benth. & Hook. f. ex Griseb., Abh. Königl. Ges. Wiss. Göttingen 19: 199. 1874. Basionym: *Oreophila meyeniana* Walp., Nov. Actorum Acad. Caes. Leop.-Carol. Nat. Cur. 19(suppl. 1): 292. 1843. *Achyrophorus meyenianus* (Walp.) Walp., Repert. Bot. Syst. 6: 336. 1846. TYPE: "Peruvia: in planitie circa Tacoram," 14,000–17,000 ft., 1831 [one label on type, "4/31," presumably indicating Apr. 1831, but another label in another hand gives "1833"], *F. J. F. Meyen 22* (holotype, B [presumably destroyed], B photos LP!, MO!). Figure 11.

Achyrophorus meyenianus (Walp.) Walp. var. *ciliatus* Wedd., Chlor. And. 1: 220. 1857. *Hypochoeris meyeniana* (Walp.) Benth. & Hook. f. ex Griseb. var. *ciliata* (Wedd.) Perkins, Bot. Jahrb. Syst. 49: 232. 1913. TYPE: Bolivia. Tarija: "en monte Calama," June 1846, *H. A. Weddell 4017* (lectotype, designated by Bortiri [1997: 227], P!; isotype, P!).

Hypochoeris meyeniana (Walp.) Benth. & Hook. f. ex Griseb. var. *eriolaenoides* Cabrera, Revista Invest. Agric. 11: 410. 1957. TYPE: Argentina. Jujuy: Sierra de Zenta, 4500 m, Feb. 1931, *E. Budin s.n.* (holotype, LP!; isotype, LP!).

Hypochoeris meyeniana (Walp.) Benth. & Hook. f. ex Griseb. var. *brachylepis* Cabrera, Fl. Prov. Jujuy 10: 677. 1978. TYPE: Argentina. Jujuy: Yavi, "alrededores de La Quiaca," *T. Meyer, A. R. Cuzzo & V. Legname 21270* (holotype, LP!; isotype, LP!).

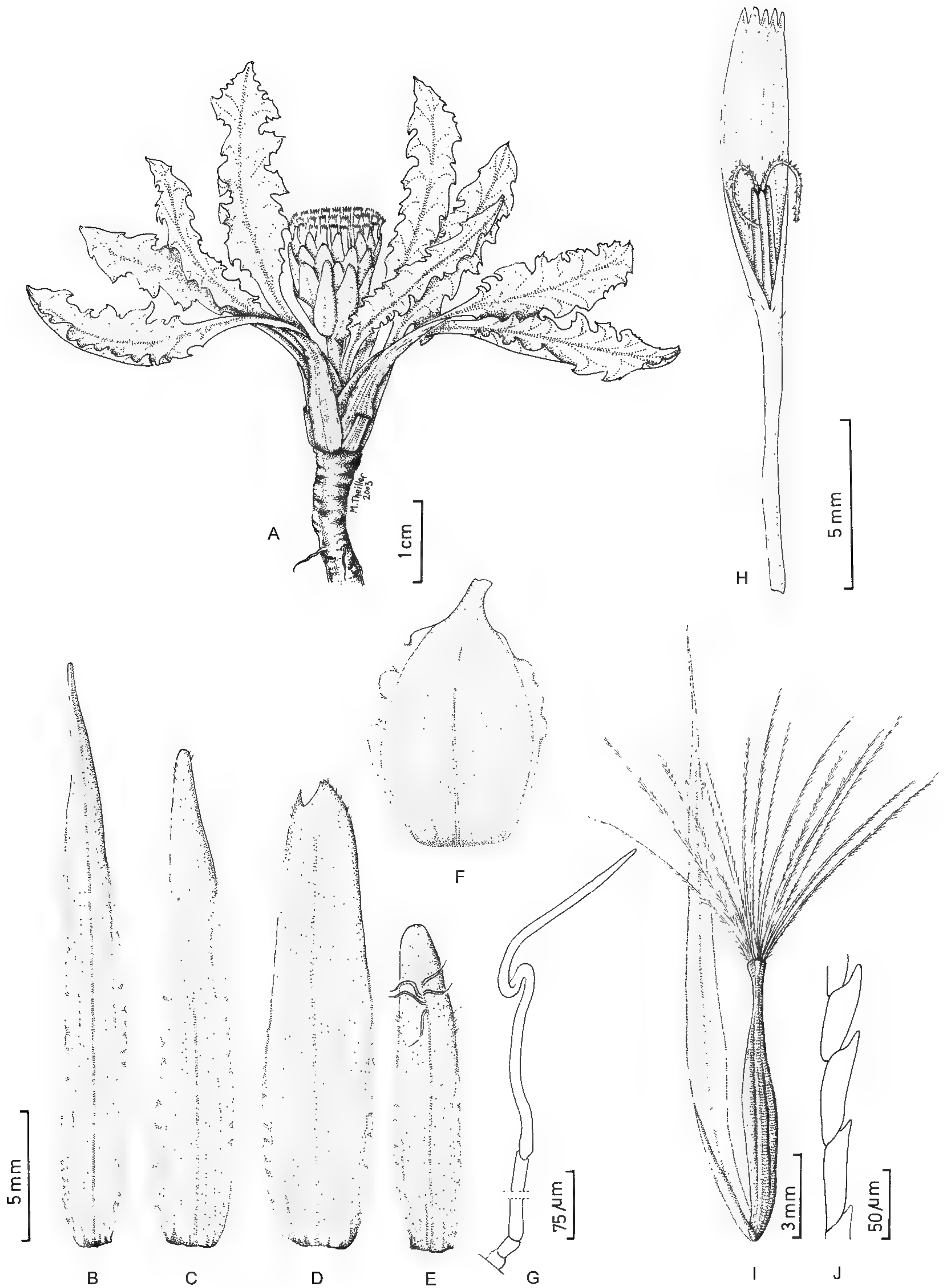

Figure 11. *Hypochaeris meyeniana*. —A. Habit. —B–F. Phyllaries. —G. Trichomes (in cilia) on phyllaries. —H. Corolla with anthers and style. —I. Palea, cypselae, and pappus. —J. Scaly cypselar wall. A–D, G–J from *Stuessy et al. 18062* (LP); E from *Meyer et al. 21306* (LP); F from *Meyer et al. 21107* (LP).

Herbs to 8 cm tall. Leaves lanceolate-elliptic or obovate, 15–150 × 5–40 mm, pinnatisect (rarely pinnatifid), runcinate, base attenuate, margin toothed or entire, glabrous or hispid on the margin (or also on the midrib). Capitula sessile or rarely with a very short peduncule. Involucre campanulate to hemispheric, 8–30 × 8–25 mm; phyllaries 3- to 4-seriate; outer phyllaries lanceolate to ovate, 7–11 × 3–7 mm, attenuate to rounded or acute, glabrous, hirsute (with shaggy trichomes) or lanuginous (with whip trichomes), margin ciliate; middle phyllaries lanceolate to ovate-lanceolate; inner phyllaries lanceolate, 13–22 × 2–2.5 mm, glabrous, slightly ciliate; paleae 13–22 mm; florets ca. 25. Corollas yellow, yellow-orange, or golden-yellow, 13–24 mm; tube 7–11 mm; ligule 6–13 mm; vascularization types 1 and 2; stamens 10–22 mm; anthers 4–6 mm; basal appendages types 2 and 3, 0.3–1 mm; filaments 6–16 mm; antheropodium type 1; style 11–22.5 mm, with branches 2–4.5 mm. Cypselae slightly constricted at apex, 2–10 mm; wall scaly or smooth; pappus 7–17 mm. Chromosome numbers $2n = 8, 16$ (Diers, 1961; Weiss et al., 2003; Weiss-Schneeweiss et al., 2007).

Habitat and distribution. *Hypochaeris meyeniana* occurs from Peru to northwestern Argentina, on rocky and/or sandy slopes, in dry and humid places, 1700–4800 m (Fig. 4D). *Hypochaeris meyeniana* grows sympatrically with *H. taraxacoides*, but they occupy different microhabitats, dry places versus bogs, respectively.

Phenology. *Hypochaeris meyeniana* flowers throughout the year.

Common names. “Achicoria” (Argentina, *Cabezas 25, Cabrera 7723, 12121*); “chambi” (Bolivia, *Pestalozzi 206*); “kawi kawi” (Bolivia, *Pestalozzi 939*).

Morphological characters. *Hypochaeris meyeniana* is polymorphic, with phyllaries ranging from lanceolate to ovate, generally glabrous, sometimes with shaggy trichomes. As a result of these and other morphological variations, several varieties have been described within the species. *Hypochaeris meyeniana* var. *brachylepis* was described by Cabrera (1978) to have phyllaries wider (more than 5 mm) than those normally encountered in this species. Likewise, *Hypochaeris* (as *Achyrophorus*) *meyeniana* var. *ciliata* was regarded as distinct by Weddell (1857) for plants with pubescent phyllaries. Variety *eriolaeoides* was described by Cabrera (1957) for plants characterized by deeply runcinate leaves and tomentose phyllaries. None of these features shows a consistent geographic pattern to warrant varietal status, and hence we treat *H. meyeniana* as a taxon in a broad sense.

Conservation status. Our field studies reveal that the conservation status of *Hypochaeris meyeniana* is very good. We found many and large populations, in both dry and humid rocky places in puna and prepuna (with *Trichocereus pasacana* (F. A. C. Weber) Britton & Rose, “cardon,” Cactaceae Juss.) in Jujuy Province, Argentina, and in La Paz Department, Bolivia. In Cochabamba Department, Bolivia, it occurs in *Polylepsis tomentella* Wedd. (“tabaquillo,” Rosaceae Juss.) woods.

Observation. The type of *Achyrophorus meyenianus* was probably collected in Chile. See comments on this same locality under *Hypochaeris taraxacoides*.

Bortiri (1997) placed *Hypochaeris meyeniana* var. *ciliata* into synonymy of *H. sessiliflora*, a referral with which we do not agree. Description of “feuilles roncinées” suggests placement here in *H. meyeniana*.

Representative specimens. ARGENTINA. **Catamarca:** Andalgalá, subida al cerro Yutuyaco desde Capillitas, *Sleumer 2730* (LP); Belén, faldeos al N de Portezuelo del río Blanco, arriba de Granadilla, *Sleumer & Vervoorst 2589* (LP, UC). **Jujuy:** Cachi, camino a Mina Don Otto, 4–5 km al S de la ruta a Cachi, *Novara 10644* (MCNS); Cochino, Abra Pampa, *Vignati 445* (LP [2], NY); Humahuaca, 20.7 km N of Humahuaca on rte. 9, *Stuessy, Urtubey & Tremetsberger 18068* (LP [2], WU); Rinconada, Mina Pirquitas, *Schwabe, Ancibor & Vizini 1098* (LP); Mina Aguilar, II-1968, *Fernández 2029* (LP); entre Cachi y San Carlos, camino a Isonza, del cruce de la R 33 a la bifurcación del Santuario, *De la Fuente & Díaz 10905* (MCNS); San Carlos, Cuesta de Isonza, 20 km S de Piedra del Molino, *Novara & Neumann 9781* (MCNS); Susques, planicie al pie del cerro Tuzgle, *Werner 89, 91, 103, 131* (LP); Tilcara, abra de Yala, *Fabris, Crisci & Petriella 6514* (LP); Tumbaya, *Stuessy, Urtubey & Tremetsberger 18062* (LP [3], WU); Valle Grande, Santa Ana, Cerro Ronque, *Kiesling et al. 581* (LP); Yavi, Quebrada de Cajas, *Cabrera 7826* (LP); Chalgumayoc, 15–20 km SE de Yavi, 15 km S RP 5, Km 35–38, *Tolaba, Acuña, Arapa, Gutiérrez, Quiroga, Ragno, Ramallo & da Silva 1677* (MCNS); Abra Colorada, costados de RP 5, Km 40–45 (camino a Santa Victoria), pasando quebrada de Cajas, *Tolaba, Acuña, Arapa, Gutiérrez, Quiroga, Ragno, Ramallo & Da Silva 1652* (MCNS). **La Rioja:** Famatina, entre Los Corrales y Cueva de Pérez, *Cabrera et al. 27174* (SI). **Salta:** Iruya, Lomán, alrededores del pueblo de Delfina Díaz, 2 km al W de San Isidro, 14 km al NW de Iruya, *Tolaba, Ragno & Quiroga 1235* (MCNS); Pantipampa, alrededores del puesto de Concepción Bustamante, filos del cerro al N de San Isidro, 12 km NW de Iruya, *Tolaba, Ragno & Quiroga 1198* (MCNS); Orán, Caucillar, *Hilgert & Lamas 1654* (MCNS); Poma, Abra Muñaño, *Cabrera 8982* (LP); Santa Victoria, RP 7, Km 12, *Deginani, Cialdella & Bortiri 806* (SI); Nazareno, 200 m al S del pueblo, *Adler 2* (MCNS); San Carlos, Alturas de Amblayo, valle Isonza, 10 km S de valle Encantado, *Novara 6356* (MCNS). BOLIVIA. **Chuquisaca:** Colomi, near Cochabamba, *Balls 6232* (K). **Cochabamba:** Apopaya, cuenca Río Tambillo, estancia Pajchanti, *Baar 386* (LPB); Arque, proximidades a la comunidad de Kutimarca y Sumuruni, camino hacia Arque, *Mercado 2181* (K); Chaparre, Cerro Guakanquí, *Steinbach 9696* (K); Cochabamba, Vacas, *Cárdenas 4347* (US); Quillacollo, camino Sipe-Sipe-

Lipichi, *Hensen 789* (LPB); Mizque, Sacha Ioma, *Ramírez 203* (LPB). **La Paz:** Chaparre, about 50 km SE of Cochabamba, on rd. to Chimore, *Eyerdam 25059* (K, UC); Ingavi, Tihuanaco, *Balls B6361* (K, UC); Inquisivi, Cruz Sayaquira, 10 km SW of Quime, *Lewis 37146* (US); Larecaja, ca. 23 km N of Sorata, along rd. toward Consata, *Luteyn & Dorr 13780* (US); Los Andes, valle de Hichu Kkota, *Ostria 132* (LPB); Murillo, La Paz, Calacoto, 60 km hacia Nevado Illimani, Panguyo, *Beck 9060* (SI); Omasuyos, el camino principal a Peñas, 18 km via mina Fabulosa, Hichukkota, *Beck 2861* (LPB, US); La Paz, Challapampa, *Asplund 4886* (US); Pacajes, 39 km from La Paz along rd. to Guaqui, *King & Bishop 7504* (US). **Oruro:** Saavedra, Kanton Amarete Felsen enmittelbar nördlich des Ortes, *Krach 8417* (SI). **Potosí:** above presa Incachaca, 10 km from La Paz páramo, *Stuessy, Tremetsberger & Hössinger 18504* (LP); Chayanta, Cruz Kasa, *Zamora 156* (LPB); Frías, Potosí, "Las Lecherías," *Schulte 129* (LPB). **Tarija:** Aviléz, lagunas de Tajsara, *Meyer, Cuezco & Legname 21517* (LP); Méndez, cerca Pasajes, *Bastián 334* (US); Tarija, de Tarija a Iscayada, *Kiesling et al. 3801, 3826* (SI). **CHILE. Región I:** Arica, camino de Arica a Portezuelo de Chapiquiña, *Ricardi, Marticorena & Matthei 343* (CONC); Parinacota, camino entre Putre y Socoroma, Km 17, *Matthei & Rodriguez 290* (CONC). **Región III:** Huasco, Vallenar, Río Laguna Grande, *Werdermann 247* (LP [the label of this collection bears the herbarium name, *Hypochoeris glacialis* Weder., which was never published]). **PERU. Ancash:** Bolognesi, Ocos, *Cerrate 6025* (SI); Huaylas, Distr. Pamparomas, Path Karka to laguna Negra Huacanam, *Weigend 2000/615* (NY). **Arequipa:** Arequipa, Paso del Cóndor, i.e., pass on continental divide on Puno–Arequipa Rd., *Iltis & Ugent 1495* (US). **Ayacucho:** betw. Huanta and hacienda Pargora, *Killip & Smith 22191* (US). **Cajamarca:** Cajamarca, entre la Encañada y Jalca de Kumulca, *López Vega 1607* (SI); Contumazá, Cascabamba (arriba de Contumazá), *Sagástegui et al. 10006* (US). **Huancavelica:** Castrovirreina, near Córdova, *Metcalf 30280* (US); Huancavelica, Occopampa, entre Laria y Tambopata, a 25 km de Conaica, *Tovar 842* (LP). **Junín:** Jauli, Anticona bajo, *Guillén & Riccio 10784* (US). **Lima:** Canta, Ijadero, a 20 km NE de Canta, *Meza 149* (LP); Huarochiri, Distr. San Mateo, Río Rimae, *Saunders 822* (K). **Puno:** Huarochiri, Distr. Matucana, Km 85 on hwy., *Saunders 379* (BM). **Tacna:** 20 km above Candasave on rd. from Mazo Cruz just S of Volcán Tutupaca, *Weigend & Förther 97-790* (K).

7. *Hypochoeris echegarayi* Hieron., Bol. Acad. Nac. Ci. 4(1): 51. 1881. TYPE: Argentina. San Juan: Barriales de Leoncito, Dec. 1875–Jan. 1876, *D. S. Echegaray s.n.* (holotype, CORD, not located; isotype, LP!). Figure 9.

Achyrophorus setosus Wedd., Chlor. Andina 1: 220. 1857. *Hypochoeris setosa* (Wedd.) Rusby, Bull. New York Bot. Gard. 4: 402. 1907, non *Hypochoeris setosa* Formánek, 1897. TYPE: Bolivia. Potosí: "environs de Potosi," 15–28 Mar. 1833 [Papavero, 1971], *A. C. V. D. d'Orbigny 1425* (lectotype, designated by Cabrera [1978: 674], P!; isotypes, MO!, P!, W!).

Hypochoeris ornata J. Kost., Blumea 5(3): 660, fig. 3a, b. 1945. TYPE: Bolivia. Oruro: "am cerro de Oruro auf steinigem trockenem Boden," 3800 m, Nov. 1911, *T. C. J. Herzog 2522c* (holotype, L, digital image!).

Hypochoeris meyeniana (Walp.) Benth. & Hook. f. ex Griseb. var. *leucantha* Cabrera, Revista Invest. Agric. 11(4):

410. 1957. TYPE: Argentina. Jujuy: Yavi, Quebrada de Cajas, 4000 m, 1 Feb. 1943, *A. L. Cabrera 7837* (holotype, LP!).

Herbs to 5 cm tall. Leaves lanceolate or oblong, 20–70 × 3–10 mm, apex acute, base attenuate in a broad petiole, pinnatipartite to pinnatisect, runcinate, margin entire or toothed, hirsute to glabrous. Capitula pedunculate (to 2 cm), rarely sessile. Involucre campanulate, 10–25 × 8–20 mm; phyllaries 3- to 4-seriate; outer phyllaries lanceolate, 7–11 × 2–2.5 mm, apex acute or semiobtusate, hirsute on middle nerves (many to few shaggy trichomes), margin hyaline; inner phyllaries oblongate or lanceolate, 12–14 × ca. 2 mm, hirsute (shaggy trichomes) to glabrous; paleae 7–17 mm; florets 10 to 20. Corollas white, 13.5–20 mm; tube 7–10 mm; ligule 6.5–10 mm; vascularization type 1; stamens 14–17 mm; anthers ca. 5 mm; basal appendages type 2, 0.6–0.8 mm; filaments 9–12 mm; antheropodium type 1; style 12–15 mm, branches 2–3 mm. Cypselae 5-ribbed, unbeaked or slightly narrower at the apex, 2–6 mm; wall scaly or smooth; pappus 12–14 mm. Chromosome number unknown (a possible hybrid with *Hypochoeris meyeniana*, however, has been reported as $2n = 16$; Weiss-Schneeweiss et al., 2007).

Habitat and distribution. *Hypochoeris echegarayi* occurs in the mountains of Peru to northwestern-western Argentina (to San Juan Province), in bogs or dry places, 3100–4950 m (Fig. 4C, triangles).

Phenology. *Hypochoeris echegarayi* flowers from December to March.

Common name. "Q'ausilla" (Bolivia, *Pestalozzi 194*).

Morphological characters. *Hypochoeris echegarayi* has shaggy trichomes on the leaves, phyllaries, and corollas. This species is closely related to *H. eremophila*, which has yellow corollas.

Observations. *Achyrophorus sessiliflorus* (Kunth) DC. var. *subruncinatus* A. Gray (1861: 146) is an illegitimate name that included both *A. setosus* Wedd. and *A. eriolaenus* Sch. Bip. as synonyms. The diagnosis by Gray (1861) corresponds more closely to the former than to the latter.

During 1874 and 1883, Hieronymus worked in the herbarium CORD of Argentina (Stafleu & Cowan, 1979), and his main collection is deposited there. In a thorough search of that herbarium, we have been unable to locate holotype material.

Cabrera (1957) originally described *Hypochoeris meyeniana* var. *leucantha* as new based on its white flowers. In 1978, he relegated this name to synonymy under *H. echegarayi* Hieron.

The small specimen of *Hypochaeris ornata*, plus the clear figure that accompanies the protologue, showing diagnostic features of campanulate involucre, setulose phyllaries, and runcinate leaves, allows referral to *H. echeagarayi*. The protologue (Koster, 1945) does not mention the color of the corollas, and the colors of the specimen are faded.

Representative specimens. ARGENTINA. **Jujuy:** Cochinnoca, Mina Aguilar, Meyer, Cuzzo & Legname 21305 (LP); Humahuaca, Mina Aguilar, Cabrera et al. 19002 (LP); Rinconada, Mina Pirquitas, Quebrada Cortadera, Schwabe, Ancibor & Vizini 909 (LP); Santa Catalina, ciénaga cerca de Cienaguillas, Cabrera et al. 15393 (LP, NY); Tumbaya, Abra Grande de Volcán, Sleumer 3507 (SI); Yavi, Quebrada de Cajas, Cabrera et al. 21505 (LP); alrededor de La Quica, Hunziker & Caso 6039 (LP). **San Juan:** Iglesia, Reserva San Guillermo, Los Caserones, Casal, Pujalte & Reza 17 (SI). **Tucumán:** Tafí, Cumbre de Chaquivil, Olea 241 (UC). BOLIVIA. **Cochabamba:** Tapacarí, 2 km al E de Japo K'asa (Km 125 Cochabamba-Oruro), cerro Kampiyani, Pestalozzi 194 (LPB); 42 km from Caracollo, on the rd. to Cochabamba, King & Bishop 7530 (US). **La Paz:** Aroma, Fisel U-123 (LPB); Juan Bautista Saavedra, Mergel-Kalksandstein-Hornstein-Lager, ca. 1 km S Kreuzung an der Straße nach Escoma, Krach 7672 (LP, SI); Inquisivi, Quime, 25 km hacia Caxata, Beck 17244 (LPB, US); Pedro Domingo Murillo, vic. of lago Zongo at the head of the Zongo valley, Solomon 13153 (LPB, NY); Presa Incachaca, 10 km NE from La Paz, Stuessy, Tremetsberger & Hössinger 18503 (LP); 13.4 km N of Huilacala, Stuessy, Tremetsberger & Hössinger 18515 (LP); laguna Cañuma, N.P., Stuessy, Tremetsberger & Hössinger 18516 (LP); 3 km E from Kalullo (ca. 38 km NNE from La Paz), valle de Achachicala, Stuessy, Tremetsberger & Hössinger 18525 (LP); Franz Tamayo, Puyo-Puyo (Ulla-Ulla), Menhofer X-1880 (LPB); Pacajes, entre Corocoro y Topohoco, Ceballos et al. 180 (SI). **Oruro:** Sajama, Cantón Lagunas, Loza de la Cruz 253 (LPB). **Potosí:** N de Potosí, entre Bolívar y Oruro, Fernández Casas 8025 (NY). PERU. **Lima:** Huarichori, Casapalca, Marcapomacocha rd. to Ratontay, Sanderman 853 (K). **Puno:** Puno, San Antonio de Esquilante, minas de San Antonio, Sanderman 3915 (K).

8. *Hypochaeris eremophila* Cabrera, Notas Mus. La Plata 13: 22. 1948. Replacement name for *Distoecha taraxacoides* Phil., Anales Mus. Nac. Santiago de Chile 8: 37, tab. 2, fig. 2. 1891, non *Distoecha taraxacoides* Ball, 1885. TYPE: Chile. Región III: Copiapó, Colorados [26°59'S, 68°56'W; Muñoz Pizarro, 1960: 171], 3600 m, 15 Jan. 1885, A. Philippi s.n. (lectotype, designated here, SGO 65208!, SGO photo LP!, SGO digital image!). Figure 10.

Herbs to 7 cm tall. Leaves lanceolate or obovate, 20–70 × 5–12 mm, generally deeply runcinate, glabrous or hispid principally on the midrib, base attenuate in a broad petiole, margin toothed or entire. Capitula pedunculate to 30 mm, rarely sessile. Involucre campanulate-cylindrical, 13–18 × 10–18 mm; phyllaries 3-seriate, lanceolate, apex acute, margin with shaggy trichomes to 7 mm long; outer

phyllaries 10–14 × 2.5–4 mm; inner phyllaries acute or slightly obtuse, glabrous or only slight trichomes, 14–17 × 2–3 mm; paleae 11–14 mm; florets 15 to 25. Corollas yellow to yellow-orange, 12–20 mm; tube 5–10 mm; ligule 7–10 mm; vascularization type 1; stamens 11–18 mm; anthers 5–6 mm; basal appendages type 2 or 3, 0.8–1 mm; filaments 6–12 mm; antheropodium type 1; style 10–14 mm, with branches ca. 3 mm. Cypselae 5-ribbed, transversely wrinkled, erostrate, narrowed at the apex, 2.3–4 mm; wall scaly; pappus 7–11 mm. Chromosome number $2n = 8$ (Weiss-Schneeweiss et al., 2007).

Habitat and distribution. *Hypochaeris eremophila* occurs from southern Peru to northwestern Argentina, inhabiting dry places, bogs, and “mallines,” 2800–4700 m (Fig. 4C, stars).

Phenology. *Hypochaeris eremophila* flowers from November to April.

Common names. “Achicoria” (Argentina, Cabrera 8399); “cóndor siki” (Bolivia, Meneses P602-6).

Morphological characters. *Hypochaeris eremophila* can be distinguished from the other acaulescent species of *Hypochaeris* by its peduncles with cylindric-campanulate involucre, phyllaries with shaggy trichomes on the abaxial surface, and yellow (sometimes yellow-orange) corollas.

Observation. Cabrera (1948: 22) proposed the name *Hypochaeris* [*Hypochoeris*] *eremophila* when he moved *Distoecha taraxacoides* into *Hypochaeris*, because *H. taraxacoides* Ball was already occupied. See more detailed comments under *H. taraxacoides* in this treatment.

Muñoz Pizarro (1960) listed two original specimens of *Distoecha taraxacoides* from the type locality in Philippi's herbarium at SGO. We have selected SGO65208 as lectotype because it is the better of the two specimens.

Representative specimens. ARGENTINA. **Catamarca:** Belén, camino a Antofagasta, Pasto Ventura, Cabrera, Botta & Deginani 32555 (SI). **Jujuy:** Susques, Quebrada de Tocomar, Cabrera 8278 (LP); al pie del Cerro Tuzgle, Cabrera 8399 (LP); Tumbaya, 33.3 km W of Purmamarca, Stuessy, Urtubey & Tremetsberger 18064 (LP [2]); Valle Grande, subida a cerro Amarillo desde Alto de Calilegua, Kiesling, Ulibarri & López 1720 (SI). **Salta:** Cachi, Cerro de Cachi, Spegazzini s.n. (LP); Guachipas, Pampa Grande, Spegazzini s.n. (LP); Pastos Grandes, Abra del Gallo, Cabrera 9051 (LP). **Tucumán:** Tafí, Tafí, cumbres Calchaquíes, Co. Bayo alrededores del refugio, Gómez Sosa & Múlgura 157 (SI [2]). BOLIVIA. **Cochabamba:** at Challa, on the rd. to Cochabamba, King & Bishop 7538 (US). CHILE. **Región II:** Loa, Collahuasi, quebrada Capella, Pisano & Venturelli 1726 (LP). PERU. **Puno:** Grau, Chuquibambilla, Pennell 13362 (US).

9. *Hypochaeris acaulis* (J. Rémy) Britton, Bull. Torrey Bot. Club 19: 371. 1892. Basionym:

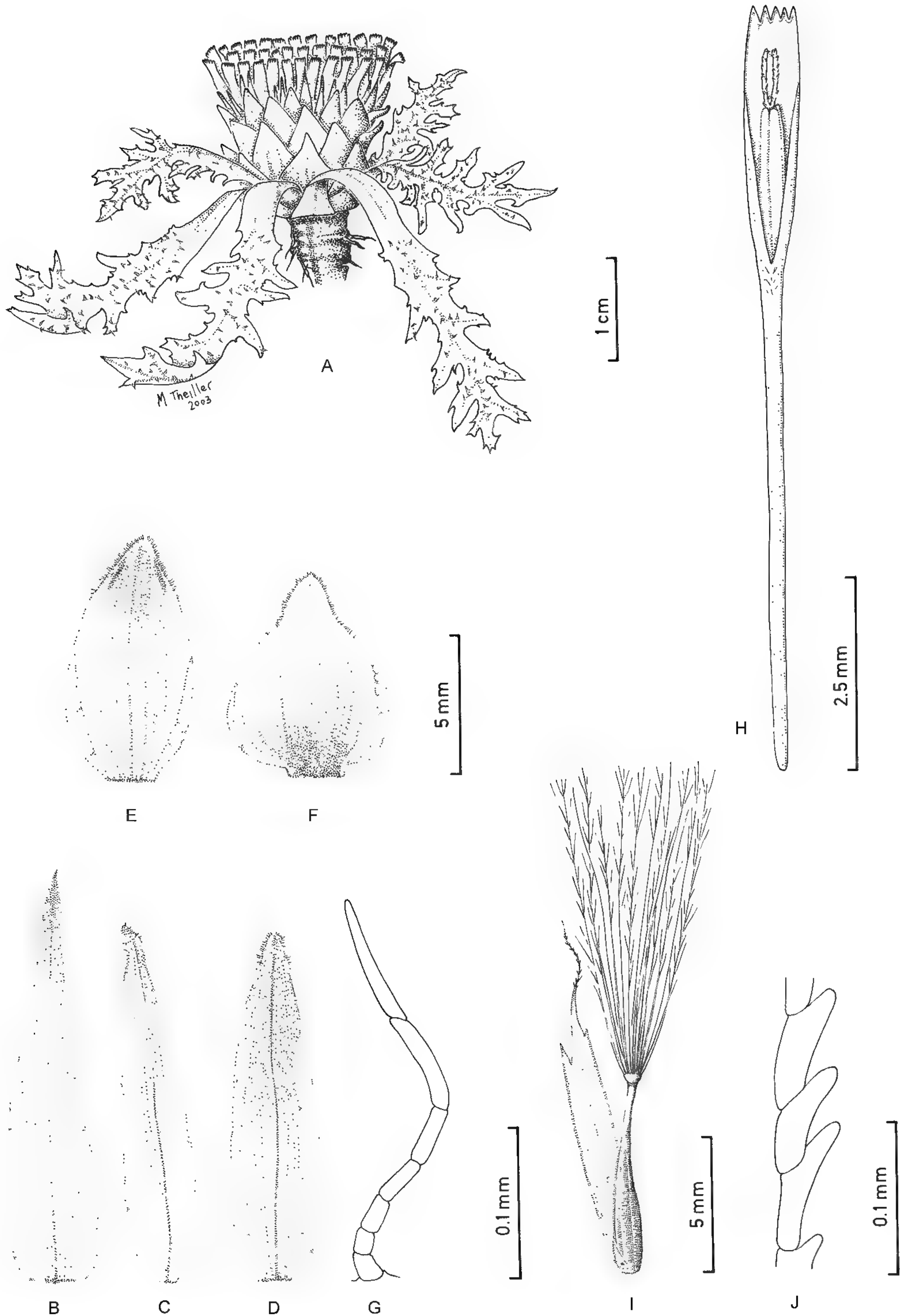

Figure 12. *Hypochaeris acaulis*. —A. Habit. —B–F. Phyllaries. —G. Trichomes (in cilia) on phyllaries. —H. Corolla with anthers and style. —I. Palea, cypselae, and pappus. —J. Scaly cypselar wall. From López 1825 (LP).

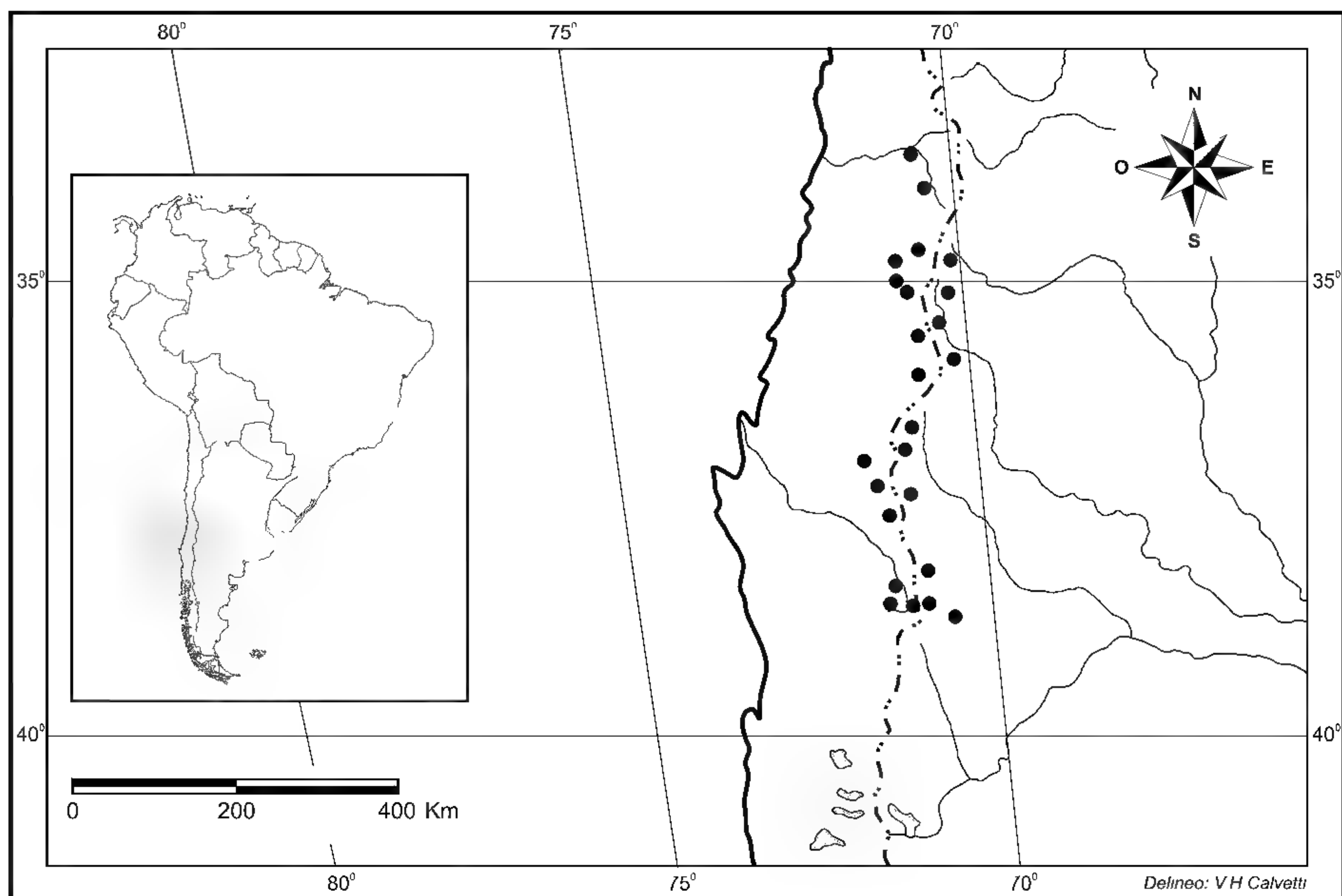

Figure 13. Distribution of *Hypochaeris acaulis* in the southern Andes (Chile and Argentina).

Achyrophorus acaulis J. Rémy, in Gay, Fl. Chil. 3: 448. 1847 [late 1848 or early 1849; Stafleu & Cowan, 1976]. TYPE: Chile. Region VI: Cachapoal, "Se cria en los prados pantanosos de las altas cordilleras de Talcalegue, provincia de Colchagua," 5–7 Feb. 1831 [Muñoz Pizarro, 1944], C. Gay s.n. (holotype, P not seen, P photo SI!; isotype, K!). Figure 12.

Herb to 5 cm high. Leaves oblongate, 32–60 × 12–20 mm, pinnatisect, with divisions antrose, base attenuate in a broad petiole, margin entire or toothed, with some shaggy trichomes (also on nerves) or glabrous. Capitula sessile. Involucre campanulate or hemispheric, 13–23 × 10–25 mm; phyllaries 4- to 6-seriate; outer phyllaries broadly ovate, 8–10 × 6–8 mm; inner phyllaries lanceolate, 8–15 × 3–5 mm, margin ciliate; paleae 13–16 mm; florets ca. 40. Corollas yellow, 10–14 mm; tube 5–6.5 mm; ligule 5–7.5 mm; vascularization type 1; stamens 7–9 mm; anthers ca. 2 mm; filaments 5–7 mm; basal appendages type 1, ca. 0.3 mm; antheropodium type 3; style 7–10 mm, with branches ca. 1.5 mm. Cypselae 5-ribbed, transversely wrinkled, 3.5–8 mm, rostrate; wall scaly; pappus 10–15 mm. Chromosome number $2n = 8$ (Wulff, 1998; Weiss et al., 2003).

Habitat and distribution. *Hypochaeris acaulis* grows only in the southern Andean Cordillera across a range about 600 × 150 km, from the regions of Santiago Metropolitan to Araucanía of Chile and provinces of Mendoza to Neuquén of Argentina (Fig. 13). It occurs between 1430 and 3000 m in

bogs, marshy places, humid meadows, stream banks, and *Araucaria araucana* (Molina) C. Koch woods. It also can be found occasionally in disturbed areas near roads and buildings.

Phenology. *Hypochaeris acaulis* flowers from December to March.

Morphological characters. *Hypochaeris acaulis* can be clearly distinguished from the other acaulescent species of the genus by its widely ovate outer phyllaries, yellow corollas slightly longer than the involucre, and the long rostrate cypselae. Tremetsberger et al. (2003a) have completed a molecular (AFLP) study of seven populations of *H. acaulis* from Chile and Argentina. All data point to restricted gene flow among populations, probably due to limited dispersal capability. There is also the expected positive correlation between genetic variation and population size. The species is postulated to be inbreeding (autogamous), based on pollen:ovule ratios, which would be consistent with the observed pattern of genetic variation. Based on other AFLP data (Tremetsberger et al., 2006), the evolutionary relationships of this taxon appear to reside with *H. palustris* and *H. tenuifolia* and not with the other acaulescent members of the South American species of the genus. This appears to be a rather dramatic case of parallelism of morphological features for survival in the high Andes.

Representative specimens. ARGENTINA. **Mendoza:** Malargüe, Paso Pehuenche, sobre la frontera con Chile, Boelcke, Bacigalupo & Correa 10379 (LP, SI). **Neuquén:** Minas, extremo S laguna Varvarco Campos, cajón del Varvarco,

Boelcke et al. 14111 (LP, SI); Ñorquín, Copahue, *Cabrera* 1440 (LP); Termas de Copahue, *Cabrera* 6154 (LP [2]); Picunches, ca. 1 km down from Pino Hachado, small laguna, *Stuessy & Baeza* 15593 (CONC, WU); Zapala, *Comber* 1257 (K). CHILE. **Región VI:** Cachapoal, Rancagua, Cordillera de Codegua, *Barros* 3790 (LP). **Región VII:** Curicó, Cordillera Volcán Peteroa, *Wedermann* 610 (BM, K, LP [2], SI, UC); Talca, laguna de Maule, *Stuessy & Baeza* 15571 (CONC, WU); Alto de Vilches, camino a laguna El Alto, *Finot & López* 1825 (CONC). **Región VIII:** Ñuble, valle de Las Nieblas (near Termas de Chillán), *Stuessy & Baeza* 15565 (CONC, WU); Bio-Bio, Los Barros, ca. 1 km N of reten de carabineros, *Stuessy & Baeza* 15703 (CONC, WU). **Región IX:** Malleco, below volcán Tolhuaca, *Stuessy & Baeza* 15817 (CONC, WU); Cautín, Cordillera Las Raíces, Lonquimay, *Burkart* 9528 (SI). **Región Metropolitana:** Santiago, Valle Largo, (Mapochotal) bei Las Condes Hochkordillera, *C. & G. Grandjot s.n.* (LP).

Literature Cited

- Babcock, E. B. 1947. The genus *Crepis*. Part two. Systematic treatment. Univ. Calif. Publ. Bot. 22: 199–1030.
- Baeza, C. M., J. Grau, E. Vovsky, T. F. Stuessy & H. Weiss. 2000. Recuentos cromosómicos en especies de *Hypochoeris* L. (Asteraceae) de Chile. Gayana, Bot. 57: 105–106.
- Bentham, G. & J. D. Hooker. 1873. *Hypochoeris*. Pp. 519–520 in G. Bentham & J. D. Hooker (editors), *Genera Plantarum*, Vol. 2. Reeve & Co., London.
- Bortini, E. 1997. Novedades en *Hypochoeris* (Compositae, Cichorieae) de la Argentina. Hickenia 2: 223–232.
- . 1999. 280. Asteraceae, parte 14. Tribu XIII. Lactuceae: *Hypochoeris*. Pp. 3–25 in L. A. Espinosa (coordinator), *Flora Fanerogámica Argentina*, Fasc. 63. Programa PROFLOA (CONICET), Córdoba.
- Cabrera, A. L. 1948. Compuestas nuevas del noroeste de la Argentina. Notas Mus. La Plata 13: 7–23.
- . 1957. La vegetación de la República Argentina. VI. La vegetación de la Puna Argentina. Revista Invest. Agric. 11: 317–412.
- . 1978. *Hypochoeris*. Pp. 671–677 in A. L. Cabrera (editor), *Flora de La Provincia de Jujuy*, Parte X. Compositae. INTA, Buenos Aires.
- Cuatrecasas, J. 1964. Studies on Andean Compositae: VI. Proc. Biol. Soc. Wash. 77: 127–156.
- Diers, L. 1961. Der Anteil an Polyploiden in den Vegetationsgürteln der westkordillere Perus. Z. Bot. 49: 437–488.
- Division of Geography (Department of the Interior). 1955. NIS Gazeteer: Bolivia. Central Intelligence Agency, Washington, D.C.
- Enock, C. R. 1908. Peru: Its Former and Present Civilisation, History and Existing Conditions, Topography and Natural Resources, Commerce and General Development. T. Fisher Unwin, London.
- Fuchs, C. 1963. Fuchsin staining with NaOH clearing for lignified elements of whole plants or plant organs. Stain Technol. 38: 141–144.
- Goloboff, P. A. 1998. Pee-Wee, ver. 3, program and documentation. Willi Hennig Society web site. <<http://www.cladistics.org/education.html>>, accessed 2 September 2009.
- Gray, A. 1861. Characters of some Compositae in the collection of the United States South Pacific Exploring Expedition under Capt. Wilkes; with observations, etc. Proc. Amer. Acad. Arts 5: 114–146.
- Harris, J. G. & M. W. Harris. 1994. Plant Identification Terminology: An Illustrated Glossary. Spring Lake Publishing, Spring Lake, Utah.
- Herzog, T. 1923. Die Pflanzenwelt der bolivischen Anden und ihres östlichen Vorlandes. Wilhelm Engelmann, Leipzig.
- Hieronymus, G. 1896. Plantae Stuebelianae novae. Engl. Bot. Jahrb. Syst. 21: 306–378.
- Hoffmann, O. 1893. *Hypochoeris*. Pp. 361–363 in A. Engler & E. Prantl (editors), *Die natürlichen Pflanzenfamilien*, vol. 4 (5). Wilhelm Engelmann, Leipzig.
- Jansen, R. K. & T. F. Stuessy. 1980. Chromosome counts of Compositae from Latin America. Amer. J. Bot. 67: 585–594.
- Koster, J. T. 1945. Plantae a Th. Herzogio initinere eius Boliviensi altero annis 1910 et 1911 collectae, Compositae, Cichorieae. Blumea 5: 659–661.
- Kunth, C. S. 1818. Compositae: *Hypochoeris*. Pp. 1–2 in F. Humboldt, A. Bonpland & C. S. Kunth (editors), *Nova Genera et Species Plantarum* (quarto ed.) 2. Sumptibus Librariae Graeco-Latino-Germanicae, Paris.
- Kuntze, O. 1898. Revisio Generum Plantarum, Pt. 3(2). Arthur Felix, Leipzig.
- McNeill, J., F. R. Barrie, H. M. Burdet, V. Demoulin, D. L. Hawksworth, K. Marhold, D. H. Nicolson, J. Prado, P. C. Silva, J. E. Skog, J. H. Wiersema & N. J. Turland (editors). 2006. International Code of Botanical Nomenclature (Vienna Code). Regnum Veg. 146.
- Metcalf, C. R. & L. Chalk. 1950. Anatomy of the Dicotyledons, Vols. 1 and 2. Clarendon Press, Oxford.
- & ———. 1979. Anatomy of the Dicotyledons, ed. 2, Vol. 1. Clarendon Press, Oxford.
- Moench, C. 1802. Supplementum ad Methodum Plantas Marburgi Cattorum.
- Morrain, S. A. 1984. Systematic and Regional Biogeography. Van Nostrand Reinhold Company, New York.
- Muellner, A. N., K. Tremetsberger, T. Stuessy & C. M. Baeza. 2005. Pleistocene refugia and recolonization routes in the southern Andes: Insights from *Hypochoeris palustris* (Asteraceae, Lactuceae). Molec. Ecol. 14: 203–212.
- Muñoz Pizarro, C. 1944. El itinerario de don Claudio Gay. Bol. Mus. Nac. Hist. Nat. 22: 27–44.
- . 1960. Las Especies de Plantas Descritas por R. A. Philippi en el Siglo XIX. Universidad de Chile, Santiago.
- Nixon, K. C. 1999. Winclada, ver. 0.99+ (BETA). <<http://www.cladistics.com>>, accessed 2 September 2009.
- Olsen, J. 1980. In Chromosome number reports LXVII. Taxon 29: 347–367.
- Papavero, N. 1971. Essays on the History of Neotropical Dipterology, with Special Reference to Collectors (1750–1905). Museu de Zoologia, Universidade de São Paulo, São Paulo.
- Parker, J. S. 1971. The Control of Recombination. Ph.D. Thesis, University of Oxford, Oxford.
- Ratzeburg, J. T. C. 1843. Meyen's Lebenslauf. Nov. Actorum Acad. Caes. Leop.-Carol. Nat. Cur. 19(suppl. 1): xiii–xxxii.
- Reiche, K. 1905. Estudios críticos sobre la flora de Chile. Anal. Univ. Chile 116: 575–606.
- Samuel, R., T. F. Stuessy, K. Tremetsberger, C. M. Baeza & S. Siljak-Yakovlev. 2003. Phylogenetic relationships among species of *Hypochoeris* (Asteraceae, Cichorieae) based on ITS, plastid *trnL* intron, *trnL-F* spacer, and *matK* sequences. Amer. J. Bot. 90: 496–507.
- Sandwith, N. Y. 1926. Humboldt and Bonpland's itinerary in Ecuador and Peru. Kew Bull. 1926: 181–190.
- Schultz Bipontinus, C. H. 1845. Hypochoerideae. Nov. Actorum Acad. Caes. Leop.-Carol. Nat. Cur. 21: 86–172.

- . 1855. Lechler's *Plantae Peruviana*. *Bonplandia* 3: 236.
- . 1856. Lechler's neueste Sammlungen aus Peru und Chile. *Bonplandia* 4: 50–54.
- . 1859. Revisio critica generis *Achyrophori*. *Pollichia* 16–17: 45–73.
- Stafleu, F. A. & R. S. Cowan. 1976. *Taxonomic Literature*, ed. 2, Vol. 1: A–G. Bohn, Scheltema & Holkema, Utrecht.
- & ———. 1979. *Taxonomic Literature*, ed. 2, vol. 2: H–L. Bohn, Scheltema & Holkema, Utrecht.
- & ———. 1981. *Taxonomic Literature*, ed. 2, vol. 3: Lh–O. Bohn, Scheltema & Holkema, Utrecht; W. Junk, The Hague.
- & ———. 1988. *Taxonomic Literature*, ed. 2, vol. 7: W–Z. Bohn, Scheltema & Holkema, Utrecht; W. Junk, The Hague.
- Steudel, E. G. 1841. *Nomenclator Botanicus*, ed. 2, Vol. 2. J. G. Cottae, Stuttgart.
- Taylor, D. W. 1991. Paleobiogeographic relationships of Andean angiosperms of Cretaceous to Pliocene age. *Paleogeogr. Paleoclimatol. Palaeoecol.* 88: 69–84.
- Tremetsberger, K., T. F. Stuessy, Y.-P. Guo, C. M. Baeza, H. Weiss & R. M. Samuel. 2003a. Amplified fragment length polymorphism (AFLP) variation within and among populations of *Hypochaeris acaulis* (Asteraceae) of Andean southern South America. *Taxon* 52: 237–245.
- , ———, R. M. Samuel, C. M. Baeza & M. F. Fay. 2003b. Genetics of colonization in *Hypochaeris tenuifolia* (Asteraceae, Lactuceae) on Volcán Lonquimay, Chile. *Molec. Ecol.* 12: 2649–2659.
- , H. Weiss-Schneeweiss, T. Stuessy, R. Samuel, G. Kadlec, M. A. Ortiz & S. Talavera. 2005. Nuclear ribosomal DNA and karyotypes indicate a NW African origin of South American *Hypochaeris* (Asteraceae, Cichorieae). *Molec. Phylogen. Evol.* 35: 102–116.
- , T. F. Stuessy, G. Kadlec, E. Urtubey, C. M. Baeza, S. G. Beck, H. A. Valdebenito, C. de Fátima Ruas & N. I. Matzenbacher. 2006. AFLP phylogeny of South American species of *Hypochaeris* (Asteraceae, Lactuceae). *Syst. Bot.* 31: 610–626.
- Uphof, J. C. 1962. *Pflanzenhaare*, Vol. 4(5). Pp. 1–206 in K. Linsbauer (editor), *Handbüch der Pflanzenanatomie*. Gebrüder Borntraeger, Berlin.
- Walpers, W. G. 1846. *Repertorium Botanices Systematicae*, Vol. 6(2). F. Hofmeister, Leipzig.
- Weddell, H. A. 1857. *Chloris Andina*, Vol. 1, Pt. 7. P. Bertrand, Paris.
- Weiss, H., T. F. Stuessy, J. Grau & C. Baeza. 2003. Chromosome reports from South American *Hypochaeris* (Asteraceae). *Ann. Missouri Bot. Gard.* 90: 56–63.
- Weiss-Schneeweiss, H., T. F. Stuessy, S. Siljak-Yakovlev, C. M. Baeza & J. Parker. 2003. Karyotype evolution in South American species of *Hypochaeris* (Asteraceae, Lactuceae). *Pl. Syst. Evol.* 241: 171–184.
- , T. F. Stuessy, K. Tremetsberger, E. Urtubey, H. Valdebenito, S. Beck & C. M. Baeza. 2007. Chromosome numbers and karyotypes of South American species and populations of *Hypochaeris* (Asteraceae). *Bot. J. Linn. Soc.* 153: 49–60.
- , K. Tremetsberger, G. M. Schneeweiss, J. S. Parker & T. F. Stuessy. 2008. Karyotype diversification and evolution in diploid and polyploid South American *Hypochaeris* (Asteraceae) inferred from rDNA localization and genetic fingerprint data. *Ann. Bot.* 101: 909–918.
- Wulff, A. F. 1998. Estudios cariológicos en Asteraceae. VIII. *Darwiniana* 35: 37–43.

APPENDIX 1. Morphological characters and character states used for cladistic analysis of the *Hypochaeris sessiliflora* complex. See also Figure 1.

1. **Habit:** caulescent or peduncle longer than leaves (0); acaulescent or peduncle never longer than the leaves (1).
2. **Stem:** simple or bifurcating (0); ramified (1).
3. **Leaf shape:** lanceolate (0); linear (1); obovate (2); elliptic (3); linear-lanceolate (4); linear-filiform (5).
4. **Leaf margin:** dentate (0); entire (1); divided (2).
5. **Leaf vestiture:** shaggy (0); whip (1); shaggy and whip (2); glabrous (3).
6. **Involucre:** campanulate (0); hemispheric (1); cylindrical (2); cylindrical-campanulate (3).
7. **Capitulum:** pedunculate (0); sessile (1).
8. **External phyllary shape:** linear-lanceolate (0); lanceolate (1); ovate (2).
9. **Phyllary vestiture (abaxial):** whip and shaggy trichomes (0); whip trichomes (1); shaggy trichomes (2); absent (3).
10. **Length of corolla:** longer than the involucre (0); as long as involucre (1).
11. **Corolla vascularization:** type 2 (0); type 1 (1).
12. **Basal appendages:** type 2 (0); type 1 (1); type 3 (2).
13. **Antheropodium:** type 1 (0); type 3 (1); type 2 (2).
14. **Cypselar shape:** rostrate (0); semirostrate (1); erostrate (2).
15. **Cypselar wall:** scaly on all surfaces (0); smooth (1); scaly on main portion only (2).
16. **Palea surface:** pubescent (0); glabrous (1).

APPENDIX 2. Data matrix used in the cladistic analysis of the *Hypochaeris sessiliflora* complex. Dashes indicate missing data or inapplicable states.

	1	2	3	4	5	6	7	8	9	10	11	12	13	14	15	16
Outgroup																
<i>H. argentina</i>	0	0	0	0	3	0	0	0	0	0	0	0	0	0	0	0
<i>H. caespitosa</i>	0	–	4	01	3	0	0	0	1	0	1	0	1	1	1	0
<i>H. chillensis</i>	0	1	0	02	13	3	0	0	013	1	1	1	1	0	0	0
<i>H. elata</i>	0	01	0	0	3	0	0	0	0	1	1	0	1	0	0	0
<i>H. hookeri</i>	1	–	5	01	13	3	0	0	1	0	1	1	0	2	1	0
Ingroup																
<i>H. acaulis</i>	1	–	1	2	03	01	1	2	3	0	1	1	1	0	2	1
<i>H. echegarayi</i>	1	–	01	2	03	0	01	1	2	0	1	0	0	12	01	1
<i>H. eremophila</i>	1	–	02	02	03	3	01	1	2	0	1	02	0	02	0	1
<i>H. eriolaena</i>	1	–	01	01	013	01	1	12	1	0	0	01	02	12	0	1
<i>H. hohenackeri</i>	1	–	1	01	3	0	0	1	3	0	1	01	02	2	1	1
<i>H. meyeniana</i>	1	–	023	2	03	01	01	12	123	0	01	02	0	1	01	1
<i>H. mucida</i>	1	–	1	02	2	0	1	1	0	0	1	1	0	2	1	1
<i>H. sessiliflora</i>	1	–	34	0	3	01	01	012	23	0	1	02	02	12	01	1
<i>H. taraxacoides</i>	1	–	01	02	3	2	0	0	3	0	0	2	0	2	1	1

APPENDIX 3. Vouchers for the cladistic analysis.

Outgroup

Hypochaeris argentina: Burkart et al. 10486 (LP); Krapovichkas 7806 (LP); Urtubey & Tremetsberger 146 (LP, WU)
H. caespitosa: Castellanos s.n. (LP); Hunziker 8649 (LP); Urtubey & Tremetsberger 145 (LP, WU)
H. chillensis: Cabrera 5688, 8595 (LP); Urtubey & Tremetsberger 114 (LP)
H. elata: Cabrera et al. 16971, 17657 (LP); Stuessy et al. 18080, 18083 (LP, WU)
H. hookeri: Stuessy et al. 18019, 18044 (LP)

Ingroup

H. acaulis: Boelcke et al. 10379 (LP); Cabrera 6154 (LP); López 1825 (LP)
H. echegarayi: Hunziker & Caso 6039 (LP); Cabrera et al. 15393 (LP); Meyer, Cuezco & Legname 21305 (LP); Stuessy et al. 18025 (LP)
H. eremophila: Burkart 5234 (LP); Cabrera 8278, 8399 (LP); Stuessy et al. 18064 (LP)
H. eriolaena: Angulo & López 1358 (LP); Hutchison, Wright & Straw 6267 (US); Macbride & Featherstone 2487 (LP, US); Velarde Núñez 3225 (LP)
H. hohenackeri: Lewis 35168 (LPB); Menhofer X-1832 (SI, LPB); Smith & Cabanillas 7212 (US).
H. meyeniana: Bundin s.n. (LP); Fabris 6514 (LP); Fernández 2029 (LP); Meyer 21270 (LP); Stuessy et al. 18062 (LP)
H. mucida: Ceballos et al. 614 (SI); Menhofer X-2197 (LPB)
H. sessiliflora: Cuatrecasas et al. 25599 (LP); Plowman 1955 (US); Molina & Barclay 18S388 (US); Stuessy et al. 18538 (WU)
H. taraxacoides: Meyer et al. 21040 (LP); Stuessy et al. 18074, 18075 (LP)

3. *Hypochaeris hohenackeri* (Sch. Bip.) Domke

4. *Hypochaeris mucida* Domke

5. *Hypochaeris eriolaena* (Sch. Bip.) Reiche

6. *Hypochaeris meyeniana* (Walp.) Benth. & Hook. f. ex Griseb.

7. *Hypochaeris echegarayi* Hieron.

8. *Hypochaeris eremophila* Cabrera

9. *Hypochaeris acaulis* (J. Rémy) Britton

Adler 2 (6); Angulo & López 1358 (5); Aristeguieta 2438 (1); Asplund 4886 (6); Baar 386 (6); Balls 6232 (6), B-6253 (2), B-6361 (6), B-6711 (2); Barclay & Juajibioy 7642 (2), 8472, 9210 (1); Barros 3790 (9); Bastián 334 (6); Beck 2861 (6), 7712 (2), 8356 (1), 9060 (6), 11914 (5), 17244 (7); Beck & Paniagua 27086 (2); Becker et Terrones 1433 (5); Blair 636 (2); Boecke & Jaramillo 2348, 2493 (1); Boelcke et al. 10379, 14111 (9); Bundin s.n. (6); Burkart 5234 (8), 9528 (9); Burkart & Troncoso 11822 (2). Cabezas 25 (6); Cabrera 1440, 6154 (9), 7723, 7826 (6), 8278, 8399 (8), 8982 (6), 8993 (2), 9051 (8), 12121 (6); Cabrera et al. 15256 (2), 15393 (7), 17656 (2), 19002 (7), 21505 (7), 22484, 22531 (2), 27174 (6), 32555 (8); Canne & Schunke 232 (5); Cárdenas 4347 (6); Casal et al. 17 (7); Ceballos et al. 164 (2), 180 (7), 548 (2), 614 (4); Cerrate 6025 (6); Cerrate & Tovar 1174 (2); Comber 1257 (9); Cuatrecasas 1484 (1); Cuatrecasas & Romero Castaneda 24560 (1); Cuatrecasas & Willard 26299 (1). Deginani et al. 806 (6); de la Fuente & Díaz 10905 (6). Ellemann 91672 (1); Ellenberg 638 (4); Eyerdam 24839 (3), 25059 (6); Ewan 16324 (1). Fabris 1369 (8), 1520 (2); Fabris et al. 4035 (2), 6514 (6); Fernández 2029 (6); Fernández Casas 8025 (7); Fiebrig 3188 (2); Finot & López 1825 (9); Fisel U-123 (7); Freueller 4384 (2). Gómez Sosa & Múlgura 157 (8); Grandjot, C. & Grandjot, G. s.n. (9); Guillén & Riccio 10784 (6). Haber 5, 142 (2); Hawkes et al. 3900 (2); Hensen 789 (6); Hilgert & Lamas 1654 (6); Hoogbe & Roesch 2534 (2); J. H. Hunziker & Caso 6039 (7); Hutchison et al. 5892 (2), 6267 (5). Ibish & Rojas 439 (5); Iltis & Ugent 1256, 1489 (2), 1495 (6). Jahn 146 (1). Kiesling et al. 581 (6), 1720 (8), 3801, 3826 (6); Killip & Smith 17641, 21680 (1), 22191 (6), 23369 (1); King & Bishop 7504 (6), 7530 (7), 7538 (8); King & Collins 9064 (2); King & Garvey 6968 (1); Krach 7492 (2),

APPENDIX 4. Index to numbered collections cited. Numbers in parentheses correspond to the species number in the List of Species.

- Hypochaeris sessiliflora* Kunth
- Hypochaeris taraxacoides* Ball

- 7672 (7), 8417 (6), 8435, 8672 (2), 9391 (2); Krapovickas 3155 (2). Leiteyn *et al.* 4995 (1); Lewis 35168 (3), 37146 (6), 38124 (3); Liberman 2343 (2); López & Sagástegui 2888, 3223, 8245 (2); López *et al.* 7421 (5); López Vega 1607 (6); Loza de la Cruz 72 (2), 253 (7), 254 (2); Luteyn & Dorr 13780 (6). Macbride & Featherstone 1791 (1), 2167 (2), 2487 (5); Maguire 39405 (1); Mandon 276 (2); Marticorena & Matthei 343 (6); Mathei & Rodríguez 290 (6); Meneses P602-6 (8); Menhofer 1036 (2), 1600 (2), X-1880 (7), X-1832 (3), X-2197 (4); Mercado 2181 (6); Metcalf 30280 (6); Meyer 21270 (6); Meyer *et al.* 21040 (2), 21305 (7), 21517 (6); Meza 149 (6), 207, 209 (5); Mezar 162 (2); Molina & Barkley 18 S.338 (1); Müller & Heinrichs 6428 (3); Müsch 151 (p.p.) (1). Novara 6356, 10644 (6); Novara & Neumann 9781 (6). Ochoa 264 (2); Olea 241 (7); Ostria 132 (6). Pennell 13362 (8); Peñafiel *et al.* 382 (1); Pestalozzi 194 (7), 206 (6), 284 (2), 292 (6), 606 (5), 939 (6); Pisano & Venturelli 1726 (8); Plowman 1955 (1). Ramírez 203 (6); Ricardi *et al.* 343 (6); Rohweder T-12 (2). Sagástegui *et al.* 9006 (5), 10006 (6); Sanderman 853, 3915 (7); Saunders 379, 822 (6), 1106 (2); Schulte 9 (2), 129 (6); Schwabe *et al.* 641 (2), 818, 819 (2), 909 (7), 1098 (6); Sleumer 2730 (6), 3507 (7); Sleumer & Vervoort 2589 (6); Smith & Buddensiek 11133 (5); Smith & Cabanillas 7212 (3), 7328 (1); Smith *et al.* 5652 (2); Soejarto 494 (1); Soderstrom 1254 (1); Solomon 13153 (7), 13177 (2); Solomon & Nee 14233 (2); Spegazzini s.n., s.n. (8); Stafford 865 (5); Steinbach 9696 (6); Steyermark *et al.* 101105 (1); Stork & Horton 10000 (5), 10838 (2); Stuessy & Baeza 15565, 15571, 15593, 15703, 15817 (9); Stuessy *et al.* 18062 (6), 18064 (8), 18068 (6), 18074, 18075 (2), 18089 (2), 18503 (7), 18504 (6), 18515, 18516, 18525 (7), 18538, 18540, 18549 (1). Tolaba *et al.* 1198, 1235 (6), 1539 (2), 1652, 1677 (6); Tovar 222 (3), 390, 393 (2), 842 (6), 850 (2), 2512 (5); Tutin 1209, 1210 (5). Vargas 11355, 11350 (p.p.) (5), 21784 (1); Vargas *et al.* 2619, 2887 (1); Velarde Núñez 3225 (5); Vignati 445 (6). Wedermann 247 (6), 610 (9); Weigend 2000/615 (6), 2000/616 (1); Weigend & Forther 97-790 (6); Werner 89, 91, 103, 131 (6), 820 (2); West 3663 (2); Wevi 129 (5); Wurdack 761 (1), 1225 (3). Zamalloa Díaz 78 (2); Zamora 156 (6); Zuloaga & Landon 4136 (1).

ANNALS OF THE MISSOURI BOTANICAL GARDEN

**VOLUME 96
2009**

Colophon

This volume of the ANNALS of the Missouri Botanical Garden has been set in APS Bodoni. The text is set in 9-point type while the figure legends and literature cited sections are set in 8-point type.

This volume has been printed on 60# Opus Gloss Recycled No. 2. This is an acid-free paper designed to have a shelf-life of over 100 years.

Photographs used in the ANNALS are reproduced using 300 line screen halftones. The binding used in the production of the ANNALS is a proprietary method known as Permanent Binding.

The ANNALS is printed and distributed by Allen Press, Inc. of Lawrence, Kansas 66044, U.S.A.

© Missouri Botanical Garden 2009

ISSN 0026-6493

Volume 96, Number 1, pp. 1–214 of ANNALS OF THE MISSOURI BOTANICAL GARDEN was published on 23 April 2009.
Volume 96, Number 2, pp. 215–368 of ANNALS OF THE MISSOURI BOTANICAL GARDEN was published on 7 July 2009.
Volume 96, Number 3, pp. 369–520 of ANNALS OF THE MISSOURI BOTANICAL GARDEN was published on 28 September 2009.
Volume 96, Number 4, pp. 521–726 of ANNALS OF THE MISSOURI BOTANICAL GARDEN was published on 30 December 2009.

www.mbgpress.org

CONTENTS

A Revision of the Malagasy Endemic <i>Helmiopsis</i> (Malvaceae s.l.)	Wendy L. Applequist	521
A Revision of Neotropical <i>Bonyunia</i> (Loganiaceae: Antonieae)	Jason R. Grant	541
Phylogenetic Position and Taxonomic Classification of <i>Aethionema trinervium</i> (Brassicaceae): A Morphologically Variable Subshrub from Southwestern Asia	Ahmad Reza Khosravi, Fernand Jacquemoud, Sasan Mohsenzadeh, Marck Menke & Klaus Mummenhoff	564
A Systematic Revision of <i>Gaertnera</i> (Rubiaceae, Gaertnereae)	Simon T. Malcomber & Charlotte M. Taylor	575
Cryptic Dioecy in <i>Nyssa yunnanensis</i> (Nyssaceae), a Critically Endangered Species from Tropical Eastern Asia	Bao-Ling Sun, Chang-Qin Zhang, Porter P. Lowry II & Jun Wen	672
Systematics of the South American <i>Hypochaeris sessiliflora</i> Complex (Asteraceae, Cichorieae)	Estrella Urtubey, Tod F. Stuessy & Karin Tremetsberger	685
Checklist for Authors		717
Author Index		720
Subject Index		722

Cover illustration. *Galianthe longifolia* (Standl.) E. L. Cabral, drawn by Laura Simón.