



3 1761 05478924 3

628.4

UNIVERSITY OF TORONTO
DEPARTMENT OF CIVIL ENGINEERING
MANUSCRIPTS SUBMITTED

CANADIAN
SOCIETY OF CIVIL
ENGINEERS



TORONTO
BRANCH

~~UNIVERSITY OF TORONTO
DEPARTMENT OF CIVIL ENGINEERING
Municipal and Structural
ENGINEERING INSTITUTE
OF CANADA
No.~~

UNIVERSITY OF TORONTO
DEPARTMENT OF CIVIL ENGINEERING
Municipal and Structural

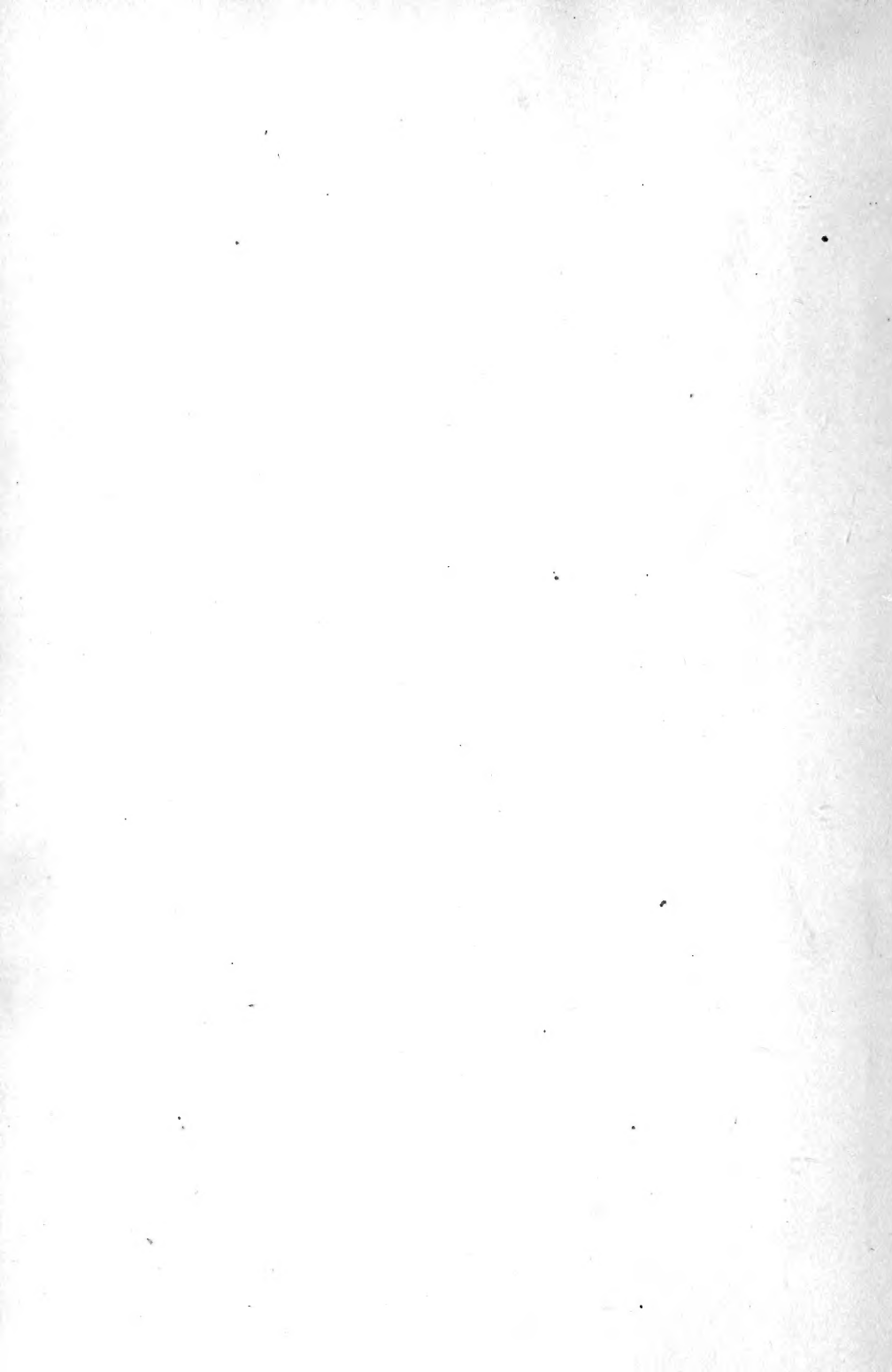

Digitized by the Internet Archive
in 2007 with funding from
Microsoft Corporation

MODERN METHODS

OF

STREET CLEANING

BY

GEORGE A. SOPER, PH.D.

Member American Society of Civil Engineers



NEW YORK

THE ENGINEERING NEWS PUBLISHING COMPANY

LONDON: ARCHIBALD CONSTABLE & Co., LTD.

1909

Copyright, 1909

BY

THE ENGINEERING NEWS PUBLISHING COMPANY

Entered at Stationers' Hall, London, 1909

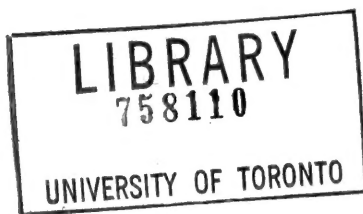

J. F. TAPLEY CO.
New York

FOREWORD

THE increasing interest taken in the matter of clean streets and the absence of any treatise which may serve as a guide to right principles and practices in this branch of sanitation has tempted me to bring together some of my notes on this subject.

These notes are based not only on my own experience, although I have been called upon to clean cities under peculiarly difficult circumstances, but more particularly upon studies which I made during a three months' visit to Europe in 1907, partly for an advisory commission on street cleaning for New York appointed by Mayor McClellan. While in Europe opportunities were afforded me to discuss the question of clean streets with many officials and I took part in the deliberations of the committee on street hygiene of the International Congress for Hygiene and Demography which met in Berlin.

Much of the statistical information contained in these pages has been kindly supplied by officials with whom I have come in contact, and to whom I am indebted for many favors. About twenty large cities were seen, including London, Paris, and Berlin. I had already visited most of these cities, once eight years before and once earlier.

By way of comparison I have added to the account of foreign methods of street cleaning a chapter on the work of the New York Street Cleaning Department,

FOREWORD

this chapter being in substance a paper prepared by me for the Association of Cleansing Superintendents of Great Britain and Ireland which met in London in 1908.

It was once my hope that a study of street cleaning methods in different cities would enable me to deduce some principles of general application, especially as to efficiency and cost, but the nature of the work and the character of the information available does not admit of many precise deductions of this kind. Numberless conditions of pavement, of traffic and of weather, not to mention different sanitary standards, make it impossible to treat this subject in the severely analytical method common in engineering discussions.

G. A. SOPER

NEW YORK,
June, 1909

CONTENTS

CHAPTER I

	PAGE
THE USE AND ABUSE OF CITY STREETS.....	1
Origin of City Streets; Uses of City Streets; City Dust; Streets as Receptacles for Refuse; The Main Sources of Street Dirt; Reasons for Extravagance and Inefficiency in Street Cleaning.	

CHAPTER II

FUNDAMENTAL PRINCIPLES APPLICABLE TO STREET CLEANING..	15
The Aim of Sanitation; Sanitary Ordinances and the Police; Duty of Magistrates; Necessity of Coöperation in Preventive Work; Coöperation with Householders; Preventable and Unavoidable Littering; Public Receptacles for Refuse.	

CHAPTER III

THE CLEANING OF PAVEMENTS.....	21
Physical Properties of Street Dirt; Chemical and Microbic Ingredients of Street Dirt; Methods of Street Cleaning; Pavements; General Methods of Street Sweeping; The Use of Water in Cleansing Pavements; Comparative Cost of Different Methods of Street Cleaning in New York; Cleansing with Rubber Scrapers; Sprinkling.	

CHAPTER IV

THE DISPOSAL OF REFUSE.....	29
Theory of Economical Utilization; Value of City Wastes; The Management of Dumps; Composition and Disposition of Refuse, Rubbish, and Garbage; Private Receptacles; Wagons and Length of Haul; Garbage Reduction; Use	

CONTENTS

PAGE

of City Wastes as Fertilizer; Burning as a Means of Final Disposal; Sea Dumping Utilization of Ashes and Clunker; The Handling of Dust and Dirt.

CHAPTER V

SUMMARY OF EUROPEAN METHODS OF STREET CLEANING..... 38

Character and Condition of Repair of Pavements; General Observations; Organization of Street Cleaning Departments; Labor; Methods of Street Cleaning; Plant and Equipment Employed; Disposal of Street Sweepings; Removal of Snow; The Collection and Disposal of House Refuse; Conclusions.

CHAPTER VI

LONDON..... 60

London an Aggregation of Cities; Importance of Central Sanitary Authority; Multiplicity of Highway Authorities; Authority over Street Cleaning; Scope of Work; Cost of Water; Character of Streets; Traffic; Street Washing; Market Places; Collection of House Refuse; Sanding of Pavements; Cleansing of Courts; Catch Basins; Work of Orderlies; Removal of Snow; Self-propelled Vehicles; Disposal of House Refuse; Personnel.

CHAPTER VII

WESTMINSTER, LONDON..... 73

Authority over Street Cleaning; Organization of Force; Method of Street Flushing; Sanding of Pavements; Removal of House Refuse; Final Disposition of Refuse; Sewer Cleaning; Depots and Plant; Utility of Motors; Street Cleaning Force.

CHAPTER VIII

MANCHESTER..... 85

The Street Cleaning Authority; Extent of Pavement of Streets; Quantities of Material Handled by Department; Methods of Cleaning the Streets; Collection of House Refuse; Collection and Utilization of Excreta; Cleanness of Depots; Plant; Municipal Country Estates; Method of Utilizing the Refuse; Quantity of Refuse Used upon the Land; Kinds of Refuse Handled; Quantities of Refuse Disposed of.

CONTENTS

CHAPTER IX

	PAGE
PARIS.....	93

The Reconstruction of the Streets; Scope of Street Cleaning Work; Personnel; Methods and Hours of Street Cleaning; Gutter Flushing; Vacations and Sick Pay; The Work of Horse Brooms; Machine Combining Broom and Scraper; Motors; Sprinkling-carts; Hose Sprinkling; Collection of House Refuse; Rag-pickers; Carts used for the Collection of Refuse; Snow; Pavements; Cost of Cleaning.

CHAPTER X

BERLIN.....	107
-------------	-----

Unfavorable Sanitary Situation of Berlin; Character of Streets; Military Character of Organization of Street Cleaning Force; Street Cleaning Force; Rewards and Sick Allowances; Length and Area of Streets; Use of Sweeping Machines; Snow; Sprinkling; The Hiring of Horses; Day Washing of Asphalt Streets; Types of Carts; Absence of Flushing; Work of Orderlies; Temporary Pits for Street Dirt; House Refuse; Cost.

CHAPTER XI

HAMBURG.....	119
--------------	-----

The Regeneration of Hamburg; The Hygienic Institute; Attractive Appearance of the City; Scope of Street Cleaning Work; Organization; Night and Day Cleaning; Asphalt; Work of Orderlies; Underground Pits for Street Refuse; Posts for the Orderlies; The Sand Used on the Pavements; Sprinkling; Snow; Final Disposition of Street Refuse; Removal of House Refuse; The Hamburg Incinerator; Arrangement of Refuse Burning Works; The Incinerator Cells; Management of Draught in the Furnaces; Exhaust Products from Burning the Refuse; Generation of Power from the Refuse; The Use of Ashes and Clinker; Quantities of Refuse Burned; Labor Required; Care of Laborers; Extra Work done by Street Cleaning Department; Cost of Horses; Quantities and Cost of Labor; Plant.

CONTENTS

CHAPTER XII

	PAGE
COLOGNE	137
Condition of City Streets in very Early Times; Insanitary Conditions Favorable to Epidemics; First Impulse for Clean Streets; Basis of Present Methods; Personal Unconcern of Citizens about the Condition of Streets; Popular Opposition to Thorough Cleansing Methods; Organization of Street Cleaning Force; Work of the Street Cleaning Bureau; Division of the City into Districts; Frequency of Street Cleaning; Day Cleaning; The Collection of House Refuse; Sprinkling; Snow; Cost of Street Cleaning; Final Disposition of Refuse; Studies of Refuse Destructors.	

CHAPTER XIII

AMSTERDAM.....	152
Peculiar Construction of City; North Sea Canal; Disposal of Sewage; Fertilizer Works; House Refuse; Compost; Collection of Refuse; Cleaning the Canals; Street Cleaning; Sprinkling; Snow; Force; Cost.	

CHAPTER XIV

NEW YORK	161
Origin of the Street Cleaning Department; The Problem of Organization and Administration; Present Organization; Duties and Difficulties; Methods of Work; House Refuse; Plant; Utilization of Useful Articles; Snow; Disposition of Refuse other than Garbage; Cost.	

MODERN METHODS OF STREET CLEANING

CHAPTER I

THE USE AND ABUSE OF CITY STREETS

THE student of municipal conditions can find much in every European city which is distinctly modern. The cities of the Old World have long since thrown off their marks of medievalism and are often more progressive than American cities. Municipal progress in Europe is rapid and substantial. A deliberate intention exists to develop and control the growth of cities along lines which make for order, convenience, comfort, safety, health, and beauty.

In no direction has greater progress been made than in sanitation. Sanitation, although long delayed, when it came, came like a revolution to continental cities. The filthy labyrinths which for centuries passed for highways and byways in foreign cities gave way to broad, handsome streets. Congested districts which thirty years ago were a reproach to civilization have been entirely eliminated. In place of over-concentration of population within the limits of military fortifications, most great continental cities now cover large, roomy areas in which the needs of public health and welfare are provided for as nowhere else in the world.

MODERN METHODS OF STREET CLEANING

It should not be forgotten that sanitary progress—in fact, the very beginnings of municipal sanitation—are due to European initiative. It is true that public water-supplies are an ancient institution and cannot be claimed as the invention of any modern civilization, but water-supplies, as we know them now, and sewers to carry away the most offensive and dangerous part of a city's filth, are a very recent European contrivance. Street lighting, good pavements, adequate transportation services, tenement-house reforms, the construction of parks and playgrounds, the regulation of vehicular travel and street paving and cleaning have been developed in Europe still more recently. The American city which ignores foreign practice in these directions fails to take account of experience which is of the utmost value.

The sanitary regeneration which European cities have experienced within the last half century has had no counterpart in America. There has been with us no necessity for such revolutionary changes. American cities were all small when the world began to learn that efficient sanitation was an indispensable feature of every municipality. There was never such overcrowding, or such slums to clean, no such foci of filth to eliminate in the United States as existed abroad fifty years ago. In 1860 there were only sixteen cities in the United States with a population of 50,000 or more, as against one hundred and forty-eight in Europe.

The significant feature of municipal growth in America as compared with municipal growth in Europe has been less the expansion of cities already large than the great number of small cities which have sprung into existence. Hundreds of these cities have passed, and are



Children Playing in City Refuse at a Public Dumping Place



Men, Women, and Children picking over mixed Refuse on the Outskirts of a small American City.



A Country Highway with a dangerous deep Gutter Running through an American Village.



Improper Drainage in a small American City.

still passing, rapidly through periods of infancy, youth, and adolescence, toward a maturity which foreign cities had reached half a century ago. Their sanitation takes place as they grow.

That branch of scavenging which has to do with the question of street cleaning is not at first troublesome to the young American city. The streets are merely highways which run from one town to another and the houses which are built upon these highways are few and far between. House refuse is disposed of in our villages in simple, not to say, primitive fashion. The ashes from fires are thrown in heaps somewhere back of the houses and often on the sidewalks and roads. Kitchen garbage is generally fed to chickens or pigs.

Origin of
City Streets

In course of time, as the population increases, the main highway is paralleled and intersected by cross roads; these again are crossed and recrossed to satisfy the growing requirements of the place. Capacious gutters make their appearance on one or both sides of the streets, but, except for an occasional drain to some brook or creek, a final disposition of surface water is not provided for. The distinctive characteristic of the village street is that it is an artery of travel built to afford facilities for men and teams to pass from town to town.

The first important public sanitary improvement to be made in the village is a public water-supply. This leads to the use of water-closets, and to accommodate the drainage from these, cesspools are built. The subject of street paving is then considered and some macadam is laid down. The streets are sometimes made wet with water from a hose in summer to keep down

the dust, but the dirt which falls upon the pavement is removed only by wind, rain, and other natural agencies. If the garbage is collected by scavengers, it is removed at the private expense of the householders. The kitchen waste is generally taken to small, dilapidated farms and, after more or less overhauling, it is fed to hogs. This progress is generally filthy and unsanitary. The young city may now be said to have passed through its period of infancy and reached its period of youth.

A sewerage system is built later in the town's growth, often long after the place has begun to call itself a city. During this period of development, the houses are gradually built closer and closer to one another until they stand in immediate contact. More attention is given to the pavement of the streets. Macadam is laid and sometimes brick; stone and asphalt come later. The ditches at the sides of the streets which formerly served as drains under the name of gutters are now eliminated and the storm water is collected from the well-graded streets through catch-basins into the sewers. For convenience in final disposal, the storm water and house sewage should be carried away separately, but they are usually removed in a combined system of sewerage.

The streets are not yet systematically cleaned. Dirt is often allowed to collect until the pavement is hidden from sight. Garbage and ashes are generally removed at public expense by contract. Sometimes the wastes are separated into two parts by the householders so that the refuse of the kitchens may be collected separately from the ashes and other wastes, and sometimes all the wastes are collected in one receptacle. If the



Fruit, Vegetables, and Meat exposed to the Dust and Dirt of an American City.



Simple method of collecting Street Dirt into Canvas Bags.



Receptacles for Ashes and Garbage often remain upon the Sidewalk in front of Residences and Business Places for Days before collection.

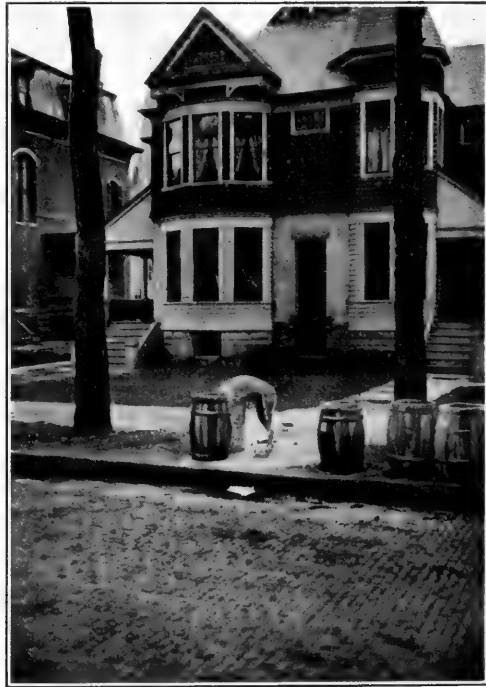

The uncovered Wooden Garbage Barrel is an unmitigated Nuisance.

THE USE AND ABUSE OF CITY STREETS

wastes are not separated, the mixture is usually taken to the outskirts of the city and dumped upon land. If kept separate, the kitchen waste is generally fed to hogs and the remainder is dumped upon land. In either case the result is likely to be unsanitary.

The city has now reached its period of adolescence. This is often a period of high mortality due to the absence of proper sanitary control. It is a period fraught with many dangers to the future of the place. It is the time to plan for the city's growth, to provide for the development of the municipality along wise and well-tried lines, to safeguard the public health in various ways and to consider civic beauty; but these matters are generally overlooked.

The period of maturity, that is, the period in which civic responsibility begins to express itself in such forms as the regulation of building construction, the control of traffic, and the adoption of other well-considered plans to insure public health and safety, is long delayed. The paving and cleaning of streets and the collection and disposition of city refuse are apt to be the last matters to which the municipality gives itself proper concern.

In appearance and use the city street is in strong contrast with the rural highway, yet the street always remains simply a highway in the public regard. The houses are now close together, offering a solid masonry front as of one compact structure. The streets are paved across from house line to house line. The earth has disappeared beneath a casing of brick, mortar, and stone which is, or should be, impenetrable to water.

The pavements should be treated as though they were impenetrable to man. Once laid, a pavement should not be broken into, but should be kept intact until

repairs to it are necessary. In American cities the pavement is being constantly broken through. It is torn up with little or no regard to the integrity and smoothness of the surface and with the sole idea of quickly reaching the pipes and conduits beneath. This integrity of surface has much to do with the cost of street cleaning.

In great cities the structures which lie beneath the surface of the pavements are numerous and complicated in the extreme. They include pipes for water, sewage, gas, steam, pneumatic mail delivery, and conduits for telegraph, telephone, electric light and power purposes, not to mention subways for the transportation of passengers. Often there is no plan or map of these subterranean structures and much digging is required to locate them.

As far as practicable, all underground structures should be placed in conduits which can be reached by man-holes. When a street is paved or repaired or the pavement extensively opened for any purpose, this fact should be advertised in advance and all necessary repairs and alterations should then be made to the underground structures so that the replaced pavement need not soon again be disturbed.

As the city grows the height of buildings becomes greater and greater, making the streets relatively narrower. This interferes with free access of air and sunlight; it leads to the overcrowding of the sidewalks and carriageways. Mile after mile this monotonous construction continues.

The city uses its streets in a very different way than does the village. The streets of the city are not only arteries of travel, they are at once places of amusement, health resorts, and business places for the people. Here persons of all ages and all tastes

Uses of
City Streets



Breaking Ice during an annual Spring Cleaning in an American City.



Improper method of Sweeping. The refuse should not be piled in the gutter.



Primitive and unsuitable Wagons which allow Papers and other Refuse to be scattered upon the Streets.



Type of Street Cleaner commonly employed in American Cities.

go to meet one another, to talk over the affairs of the day, to be entertained, to eat, to drink, to inspect shop windows, to do marketing, to buy and sell merchandise, and to perform a thousand offices which the exigencies of city life make profitable, healthful or agreeable.

How intimate is this life of the streets to the lives of the people is not likely to be fully understood by anyone who has not studied this subject in the great cities. It can best be understood in Europe.

The city streets connect every household. The city man not only moves through the streets; he carries the dirt of the streets into his home on his boots and clothing; he gets his food and air through the streets. Unfortunately both food and air are often contaminated.

It is not pleasant to consider the nature of these contaminating matters. They consist of the pulverized excretions and rejecta of thousands of human beings and animals, the wastes of hundreds of factories and shops, and, in fact, the product of the ceaseless wear and tear of everything perishable in the city. It is a rule of sanitary science that what is once rejected and cast off by the body shall not again be taken into it, but here we have all manner of excretory products taken into our bodies by food and air in plain violation of this law.

It is well to study thoroughly this question of city dirt. Ground into impalpable powder and raised from the pavements by the wind, it hangs in the atmosphere and can plainly be seen in the air like a haze on a calm day. The quantity held constantly in suspension is so great that it affects the city's climate. It discolors our persons and our clothing; it turns marble and even granite yellow and black.

City Dust

MODERN METHODS OF STREET CLEANING

Street dirt can be found in masses which weigh pounds on the tops of the tallest buildings in New York. Visible particles of sand and horse dung show its earthly origin. It is this dust which blackens the snow; which enters our homes and our hospitals in place of pure air; which settles upon food; which penetrates our cupboards and desks. It literally grinds itself into our flesh and finds its way into our blood. City dust makes the lungs of people black and aggravates diseases of the nose and throat.

The city street, like its progenitor, the country highway, is a natural outlet for filth. Here refuse of all kinds is cast from the houses. Windows are raised when rooms are swept, doors are opened when the sweepings are ready to be brushed out, rugs are beaten on sidewalks and roofs, dogs are taken out on a leash to defecate, kitchen garbage is set out on the sidewalk for scavengers to remove, old clothing and dead animals are thrown into the gutter, ashes are cast upon the carriageways, human beings expectorate, and children urinate and defecate upon the pavements.

The pavements themselves are ground down by wear and tear, and where broken, contribute a considerable amount of dirt to the streets. Every wagon-load of sand, coal, garbage, ashes, or other loose material adds its contribution as it passes. No house is built or torn down that does not add to the dirt in the streets.

Most of the solid filth which comes out of the house leaves it at the street level, but there are quarters in every great city where refuse is constantly thrown down from the windows and brought up from the cellars into the streets.

In some cities the air of the streets is polluted with



In American Villages Ashes, and sometimes Garbage, are thrown upon the Streets.



Frequent and heavy Snow Storms greatly interfere with the work of Street Cleaning.



Shoveling Garbage from Carts in a large American City.



Usual and Insanitary method of Dumping Wagon Loads of Refuse into Barges in America.

THE USE AND ABUSE OF CITY STREETS

gases from below the surface of the pavement. Sewer manholes emit clouds of steam and unpleasant-smelling vapors; grated openings provide for the escape of hot, vitiated air from workshops, stables, and boiler rooms.

Of all the sources of street dirt, the greatest amount which becomes scattered upon the pavements originates from vehicular traffic. The ceaseless move-
ment of vehicles, with their horses, contributes
materially to the soiling of city streets. The horse
dung itself is a substantial and annoying item. One
thousand horses will, in every working day of eight
hours, deposit about 500 gallons of urine and 10 tons
of dung upon the pavements. Inasmuch as over 2000
vehicles have been counted passing a given point on
the street of a city during a single hour, the quantity
of horse dung which may be deposited on a mile of city
streets is evidently very large. The residue of this
horse dung, that is, the undigested external coatings of
hay and oats, form a conspicuous ingredient of city
dirt.

**The Main
Sources of
Street Dirt**

The transportation of sand, coal, hay, manure, and other loose material in poorly constructed wagons adds to the quantity of refuse in the streets. It seems to make little difference how large is the wagon body, the contents are generally heaped or piled above the sides. Ordinances should exist prohibiting the dirtying of streets in this way.

In the average city the street-cleaning department itself adds materially to the work which it has to do. The carts are generally unsuitable for the conveyance of the kind and quantity of refuse which they have to carry. In consequence, dry refuse is blown from the carts and wet refuse drips from them. In loading refuse over the too-

high sides, some dirt is unavoidably spilled. The carts are overfilled and when they pass over irregularities in the pavements, refuse is jolted out of them.

Failure to collect house refuse with frequency and regularity causes it to be cast into the carriageways by the people and to fall upon the streets from the house receptacles. It commonly happens that street-sweepers brush refuse into piles and leave it there for many hours without removing it. Traffic and the elements pulverize and scatter the refuse under these circumstances and double the labor necessary to collect it. In many ways street-cleaning authorities by carelessness and want of knowledge of the details of their work often increase the amount and difficulty of their labor.

In most cities earth from country roads is dropped upon the pavements by the movements of vehicles. In some towns peddlers and push-cart merchants add materially to the dirtying of city streets. Finally, as sources of street dirt may be mentioned the improper storing of sand and other building materials and the sanding of pavements by street-car companies and street-cleaning authorities.

As cities grow and become more and more congested, the need and difficulty of keeping the sidewalks and carriageways free from dust and litter increases. It is obvious that a population of 1200 people per acre will produce more waste than a population of 12 per acre and will crowd the pavements more. The denser the population the more people there are likely to be on the streets. In tenement districts the carriageways are often much more frequented by pedestrians than by vehicles. Failing in resources for more healthful employment, the children turn to the filth of the streets

THE USE AND ABUSE OF CITY STREETS

and gutters in their play and find in resurrecting the rejected belongings of the neighborhood an unfailing source of amusement.

This is all wrong. From a public health standpoint the cleanness of a street should be in direct, not reverse, proportion to the congestion of population. There should be no such difference as now exists between the inside and outside of well-kept houses in respect to cleanliness. In tenement districts the sanitary condition of the streets should give the pattern for the houses.

There is an impression that the sum of money spent in cleaning the streets of the average American city is generally quite out of proportion to the results accomplished. There is much truth in this belief. Of all the work which the municipal government is called upon to perform that of street cleaning is done in the most irrational and extravagant manner.

Reasons for
Extravagance
and Inefficiency in Street
Cleaning

In spite of praiseworthy efforts here and there, the streets of but few cities are kept in a satisfactorily clean condition. There are almost always large parts of even the cleanest cities which are very dirty. In reading the descriptions of street cleaning in this book, it must clearly be understood that what is said refers as a rule to the cleanest and best parts, not to the whole, of any city.

One of the reasons for the unsatisfactory condition of city streets lies in the fact that the business of keeping a city clean is rarely understood by the public or by the officials in charge of the streets. Street cleaning has not yet emerged from the state of a nondescript kind of emergency undertaking to the position of an effective art. In American cities of small size it is still custo-

MODERN METHODS OF STREET CLEANING

mary to clean most of the streets not regularly and systematically, but spasmodically—often only when the conditions become so bad that public endurance will no longer tolerate them. The cleaning is done by an unorganized gang of laborers who swoop down upon a district and with more or less hurrah clean it up with shovels and brooms.

This spasmodic cleaning is regarded in many parts of the United States as highly praiseworthy. In cities of from 10,000 to 100,000 inhabitants it is often done with a great deal of advertisement and show. Thus a town appoints a special day as cleaning day. The school children are given a holiday so they can help their elders clean up private premises and put the streets in order. Gold prizes have been offered for the best work of this kind and the city authorities solemnly agree that teams "will haul away free of charge from any residence all ashes, leaves, cans, bottles, paper, rags, and other refuse except garbage." "Broom brigades" are sometimes formed. A city of 64,000 inhabitants in New York State announced in the spring of 1908 that it had "inaugurated the work of street cleaning by putting a force of 130 men and 40 teams at work. This is the largest force ever employed on the streets."

In some northern cities where outside work is impeded by ice and snow for several months and where the business of cleaning the streets can be carried on through the winter only at much expense, it is to be expected that the cleaning of fine dirt from the pavements must be interrupted or altogether suspended for long intervals. But to stop all efforts at cleaning private premises and public streets through a large part of the year, allowing household and other coarse as well as fine

refuse to accumulate until the city is compelled to suspend all other undertakings to clean away the filth, is to carry the matter beyond proper sanitary limits. As Waring well said, the aim should be to keep a clean city clean and not to clean a dirty city.

When an American city is regularly cleaned by a city department, there is usually more system but less efficiency about the work than when the work is done by contract. Only in the rarest instances are city employees animated by a spirit of industry and efficiency comparable with that which is indispensable in commercial enterprises.

The persons assigned to labor on the streets are, in American cities, often recruited from the ranks of the unemployed and are likely to be either incompetent or unwilling to do a fair day's work. The wages paid are sometimes large—as large as those paid to bookkeepers, artisans and clerks—and wholly incommensurate with the results accomplished. Sometimes men of advanced age, inmates of poorhouses and even convicts, are put upon the streets to clean them. Any kind of labor seems good enough to attend to this business of street cleaning.

Small wonder is it, therefore, when one considers the faulty management of the work, that the results are so unsatisfactory.

In view of the progress accomplished in other sanitary directions, it seems curious that no improvement has been made since the earliest times in the collection of household wastes other than sewage. It is little short of barbarous to place our garbage on our front doorsteps, to wait there the prey of dogs and cats and food for flies, until the scavenger's cart carries it away.

MODERN METHODS OF STREET CLEANING

The receptacle is never clean and is always, in some degree, offensive to sight and smell. If the prevalent crude ways of collecting heavy and bulky household wastes could be done away with in favor of some such plan as that by which human excrement is disposed of in cities, that is, promptly and adequately, through a transportation system of some kind, the problem of keeping cities clean would be greatly simplified. Underground transportation by water carriage is impracticable for all the wastes of a city, but systematic removal by some appropriate method can and should be accomplished.

CHAPTER II

FUNDAMENTAL PRINCIPLES APPLICABLE TO STREET CLEANING

IT should be kept in mind that it is the aim of sanitation to get control of wastes as soon as possible after they are produced and maintain this control until they are permanently disposed of. It should also be remembered that it is both easier and cheaper to collect large particles of refuse, and small particles when present in relatively large and compact masses, than to allow the refuse to be broken up and scattered before attempting to gain possession of it. City wastes should always be kept in control.

The Aim of
Sanitation

City refuse is not in control when it lies scattered in streets, alleys, and back yards. It is in control when it is in some suitable receptacle or place provided for it and on the way to its final destination. It is needless to say that the methods of collection and disposition should be so designed as to cause as little offense as possible to the eyes and nose, both to the public at large and to private householders.

House refuse, once it is gathered together for removal from the premises where it is produced, should never become scattered—that is, from the time it is produced to the time it is permanently disposed of, it should be contained in a receptacle of some kind, be that receptacle box, barrel or wagon. Refuse is no longer in

control when it falls from the receptacle in which it is placed or is blown out of its receptacle by the wind. From the moment when the refuse leaves its appointed place by accident and not design, its collection and ultimate disposal become increasingly difficult and expensive.

The practical means of keeping refuse from becoming scattered and, in particular, the ways of preventing it from littering the streets, deserve careful consideration.

People should not throw refuse into the streets or put it where it is likely to get there. Ordinances should exist to prevent careless practices in this direction and the police should see that the ordinances are enforced. It is as much the duty of the police to enforce the sanitary ordinances of a city as to arrest criminals. If it is proper for the police to regulate the movement of vehicles, to facilitate the transit of street cars, and make safe the movements of pedestrians, it is no less their duty to prevent the streets from being made a dumping-place for wastes. Yet the police of a city are usually far from appreciating their responsibility in this matter. It is too often thought by the members of the force to be beneath the dignity of a police officer to call the attention of a pedestrian or householder to the fact that he is transgressing a city ordinance by throwing refuse upon the pavements. It is not a question of trouble or of time. It would consume but an inconsiderable fraction of the day's work for the police to keep an eye open for persons who drop their newspapers in the streets. To prohibit over-filled carts of coal, ashes or sand from dribbling their contents upon freshly-cleaned pavements would be no more difficult nor time-consuming for police officers than

PRINCIPLES APPLICABLE TO STREET CLEANING

to perform any of the other functions which they regularly exercise. In fact the average policeman has a great deal of time on his hands which he does not employ to advantage in any way under present circumstances.

The magistrates before whom offenders against the sanitary ordinances of a city are sometimes brought are equal offenders with the police in this matter. Cases of proved negligence or wilful disobedience against the sanitary code are too often treated with leniency and even with levity. It is only within recent years that boards of health in their crusades against promiscuous spitting have been able to secure the imposition of fines when violators of the ordinances have been brought before the magistrates.

**Duty of
Magistrates**

In order to facilitate the work of the street-cleaning department, coöperation is desirable between those city departments which are responsible for the paving of streets, the opening of pavements, the regulation of traffic, the storing of building materials, and the management of markets. Effective coöperation of this kind is rare in America, but in Europe all these matters, and more, are not uncommonly attended to by one central authority. The importance of maintaining the streets in a condition of cleanliness and good repair is so great and the cost so large under the best circumstances, that some sort of agreement should exist among the different authorities having jurisdiction over the streets. Upon the street-cleaning authority devolves the responsibility for seeking this coöperation, for it is his work which is most affected.

**Necessity of
Coöperation
in Preventive
Work**

Successful work in keeping streets clean requires

coöperation not only on the part of city officials, but with householders, with persons engaged in various trades and occupations, and with the public at large.

**Coöperation
with House-
holders**

It is indispensable that householders should place their house refuse in suitable receptacles for temporary storage and removal. It is equally important that the public scavenger should keep faith with the people and send his carts round punctually and often enough to collect the refuse prepared for him before its presence becomes unduly offensive. Household refuse is a source of inconvenience and annoyance from the moment it is produced and no sort of receptacle or other provision for storage on the premises will take the place of frequent collections.

The littering of market places affords an illustration of the extent to which pavements may, under special circumstances, become unavoidably littered.

**Preventable
and Un-
avoidable
Littering**

An inspection of any congested business or tenement district will reveal conditions of littering, most of which can, and should, be prevented. In fact these two illustrations indicate the practical limits to which preventive treatment can be carried to keep streets clean. It would impose an impossible burden upon market men to insist that none of their refuse should fall upon the pavements; in this case there is nothing to do but clean the market well and often. On the other hand, in tenement districts and congested business quarters, much preventive work can be done by the persons who use the streets. When he was Street Cleaning Commissioner of New York, Colonel Waring formed leagues of school children to teach their parents the importance of refraining from throwing refuse upon the pavements.

PRINCIPLES APPLICABLE TO STREET CLEANING

It is a growing practice for street-cleaning departments to place barrels and baskets along the curb for the reception of newspapers and other large articles of solid refuse. Some of these receptacles bear a legend to indicate their use and often some simple catch phrase exhorting to cleanliness as, for example, "Be sanitary and you'll be sane."

Public Recep-
tacles for
Refuse

There is much to recommend this plan of public refuse receptacles, but it is important that they should be kept clean and never allowed to become overfull. They should be placed in easily accessible positions, for no one is likely to go far out of his way to use them. Proper locations for these receptacles are not easy to find. In well conducted streets obstacles should be kept out of the way of pedestrians. Standing hydrants and lamp-posts are eliminated and post-boxes set inside the house lines in some cities.

CHAPTER III

THE CLEANING OF PAVEMENTS

THE physical appearance of the dirt of the streets varies considerably. Some of the large portions consists of pieces of rejecta which can easily be removed from the pavement by scavengers with hand tools, such as shovels and brooms. Fragments of garbage, of paper and fresh horse dung belong to this class.

Physical
Properties of
Street Dirt

Other particles of street dirt are too finely ground up to permit of separate hand removal, as ashes, for example, and horse droppings after they have become scattered by traffic. In this class, also, is much of the sand, earth, and coal dust which are dribbled from overfilled wagons or allowed to get upon the streets through carelessness.

This finely ground material is the most difficult and expensive kind of street dirt to deal with. Its thorough removal is too often neglected in street cleaning. It forms a slippery, sloppy mud in wet weather and a blinding dust when the weather is windy and dry. It is necessary to deal with this material in some special manner in order to get rid of it. That manner depends upon the pavement, the amount of dirt to be dealt with, the particular uses to which the street is put, the abundance or scarcity of water available, the price and reliability of labor and the condition of the sewerage system.

THE CLEANING OF PAVEMENTS

Owing to the fact that street dirt is composed of variable ingredients mixed in variable proportions, no analysis or series of analyses is capable of exactly indicating its composition. It is too indefinite a substance to be definitely described.

**Chemical and
Microbic In-
gredients of
Street Dirt**

Little is known about the nature of the bacteria present in street dirt, although tests show they are numerous. Most of the bacteria are probably of harmless, saprophytic species. The germs of disease probably do not live long, and rarely, if ever, multiply in street dirt. The predominating kinds are, we may safely conclude, those which are concerned in the processes of decay.

To dispose of the dirt which soils the streets, two general methods exist. Innumerable as are the sources, there are but two avenues of escape. It must be picked up and hauled away in carts or it must flow with water into the sewers.

**Methods of
Street Clean-
ing**

Usually a good deal of street dirt flows away by the sewers during rain-storms, but this method of disposing of it should limit the dirt to finely divided matter. In some cities, notably Paris, the sewers have been built with the idea of carrying off all the street dirt that can reasonably be emptied into them, but there is generally objection to this practice. The best engineering opinion is that a city's sewers can, and should, be made to carry a good deal of fine dirt from the streets. The large, bulky, heavy particles must be removed otherwise.

It cannot be too often emphasized that good pavements in good repair are indispensable to good work in street cleaning. It makes less difference what kind of pavement is employed than what condition the pavement is in. Every sort of pavement

Pavements

MODERN METHODS OF STREET CLEANING

seems to have certain advantages of its own, but none is good unless its general surface is smooth and true.

The easiest to clean, but the pavement which requires the greatest amount of attention, is asphalt. The cost of cleaning has been estimated as 1, 2, 3, and 6 for asphalt, brick, granite block, and cobble-stone respectively, but these costs are not strictly comparable, because the methods and results are different. Granite blocks take more time, if the work is done by hand, than asphalt, but they do not need to be cleaned so often, nor does the dirt need to be so thoroughly removed from such a pavement in order to keep it looking tolerably well. Macadam is the most expensive pavement of all to keep clean. Wood-block pavements are said to be more expensive than asphalt and less expensive than granite block to keep in good sanitary condition. Fine, dusty dirt is most conspicuous on asphalt. A good granite pavement has a capacity for holding a considerable quantity of fine dirt in its small irregularities without causing the dirt to be offensively apparent either as dust or mud.

To remove large particles of refuse from street pavements, the custom both in Europe and America is to employ handworkers. There is a good deal of difference in the tools and equipment of these laborers and in their methods of work, but the general principle on which they proceed is the same. Their object is to pick up papers, horse droppings, and other refuse which they can easily and quickly remove and leave the pavement without conspicuous litter. In many European cities these workers are boys; in America they are often old men. This work is always done in the daytime. In America the hand-

General
Methods of
Street Sweep-
ing

cleaners sometimes go through a street in gangs, but more often they are here, as in Europe, assigned to regular patrols.

The refuse collected by these laborers is put into barrels, bags or hand-carts or thrown temporarily into bins or pits situated inside the curb-line. In some American cities small metal barrels are carried through the streets on light carriages which the workman pushes along before him. Stationary receptacles are suitable only on streets with heavy traffic.

Although the hand-workers are usually provided with shovels, iron scrapers, and brooms, and in some cases hand-propelled sweeping-machines, they do not and cannot remove all the dust and mud which it is desirable to remove from a city pavement. This can only be done by the use of water. Nor can hand-workers compete with horse- or motor-propelled rotary brooms in removing large amounts of dirt from the pavements. Handwork is best on pavements which are in poor repair. The secret of success in machine work lies in having unobstructed streets and good pavements. Machine work, like flushing, is properly night work.

The attempts made to use sweeping-machines are often decidedly crude. The brooms are not always preceded, but are sometimes actually followed, by sprinkling-carts. Too often no sprinkling accompanies the sweeping, the result being that dirt is raised through the air in clouds of dust to settle again upon the pavements and in the houses. Hand-sweeping is open to the same objection, for when sprinkling is done in connection with this work, it is often perfunctory and ineffective.

The Use of
Water in
Cleansing
Pavements

In some cities it is common to wash the pavements with water. Cleaning with water, either by means of a stream from a hose or by means of water from carts is not uncommon in America.

The term "flushing" may carry to the minds of some a misconception of the proper way in which to use water to clean a street. To most persons to flush is to carry away something which can float or be easily moved by a current of water. The dust and dirt upon a street often cannot be dislodged unless wet, except by considerable water pressure or by scrubbing. This injures the pavements. For the best results, the dirt to be removed from the pavements must first be thoroughly lubricated before the hose is used. In this lubrication lies the secret of efficient cleansing by the water method. The use of a stream of water from a hose is of value, not alone on account of its transporting powers, but from the sweeping action which can be brought about by the stream as it is directed by a skillful hand at the nozzle.

The facility with which street dirt may be removed from pavements and carried through the sewers in the presence of an abundance of water should be remembered when showers and rain storms occur. At such times a street-cleaning force can, with hose or with simple rubber hand scrapers, clean an immense amount of fine refuse from asphalt streets by way of the sewers with comparatively little expenditure of energy and of water. Instead of street-cleaners seeking shelter on the approach of rain, as is commonly the case in American cities, they should seize the opportunity to clean the pavements, for, if they do so, their work during fine weather will be much reduced.

THE CLEANING OF PAVEMENTS

In America so-called flushing-machines have been introduced within recent years. These machines are water-carts constructed to throw a stream of water with considerable force by means of air pressure as the cart is hauled along by horses. The way in which these flushing-machines are constructed is ingenious, but their use is based upon a mistaken theory. They are incapable of competing with hose flushing, for the stream lacks the adjustibility and precision of the hand. The engineering commission on street cleaning for New York reported that the work of street cleaning by flushing-machines was more expensive and less efficient than the work of cleansing with hand hose.

This commission compared the cost of street cleaning by hand-sweeping, by sweeping with horse-propelled brooms and by the use of water from a hose, and concluded that hand-sweeping was the cheapest method. In these estimates allowance was made for the cost of repairs, interest charges on the apparatus, etc. The wages of a laborer were taken at \$2.19 per day, the cost of keeping a horse at \$1.35 per day, the cost of water at \$90 per million gallons. One hand-sweeper was considered to be capable of cleaning 8000 sq. yds. of pavement in a day of eight hours, a two-horse machine 70,000 yds. In flushing with water from a hose, it was assumed that 5000 sq. yds. could be cleaned per hour with 1.88 gallons per square yard. Two laborers of the rank of sweeper were thought to be enough to operate the hose. On this basis hand-sweeping was estimated to cost \$.281, machine-sweeping \$.317, hose flushing \$.319 per 100 sq. yds. Flushing by a patented machine was estimated to cost \$.721.

Comparative
Cost of Different
Methods
of Street
Cleaning in
New York

MODERN METHODS OF STREET CLEANING

It is surprising that hand work should be so much cheaper than machine work, in view of the fact that a good machine will sweep about ten times as many square yards of pavement as will a laborer in a given time.

The charges for labor were large items of expense in the calculations for hand and machine work. In hand-sweeping the wages of the men represent almost the whole cost. In sweeping with horse brooms, the cost of labor was about 60 per cent of the whole. It was assumed that six men would be required to collect into piles the dirt which was swept into rows by a horse broom. The wages of these six men make a large item. The cost of putting the dirt into carts and hauling it away was not included in any of the calculations, although it was considered that this work would probably cost less with the hand-sweeping, since by this system the dirt is placed in barrels by the sweepers.

When we take up the estimates for flushing, we find that only two laborers were allowed for in hose flushing, but in machine flushing four laborers were considered necessary to collect the dirt in the gutters. Apparently in the one case there was no dirt to clean up and in the other there was some. The question of taking up the dirt swept or cleaned from the pavements by whatever means, appears to be the most expensive feature of street cleaning. Hose flushing is economically possible only because it carries the dirt into the sewers.

In one important respect the costs of cleaning are not comparable. The results are not the same. Hose flushing is suitable for removing a small amount of fine dirt and leaves the pavement very clean. Machine sweeping is useful for removing a comparatively large quantity of fine and relatively coarse dirt and leaves the

pavement ready to be cleaned with water from a hose or by other means. Hand-sweeping is best to pick up of coarse litter and horse droppings soon after they appear upon the pavements.

One of the most efficient ways used in Europe for cleaning smooth pavements, such as asphalt, is by means of sprinkled water speedily followed by scraping with rubber squeegees. In this case the dirt is first lubricated, then scraped away and the pavements partially dried by the scraping. Machine-scrapers hauled by horses are widely employed in Europe to clean asphalt streets. There is no difficulty in carrying this dirt through the sewers because the streets are not allowed to become so heavily coated with refuse before being cleaned that the quantity of dirt which enters the sewers is large. Where the amount of dirt on the pavement is great, most of it should first be removed by brooms before the more thorough cleansing with water begins.

Cleansing
with Rubber
Scrapers

Sprinkling is not necessary on thoroughly well cleaned pavements and in some cities it is not done. Sprinkling does not cool the air appreciably, as is popularly supposed, nor does it clean the streets.

Sprinkling

The water runs to the sides of asphalt streets and there forms pools which sometimes become offensive in hot weather. Where the streets are continually used by pedestrians, sprinkling causes annoyance while the pavement is wet. As most streets are not thoroughly cleaned, sprinkling is a favorite way to lay the dust.

Macadam roads are among those which can be sprinkled to good advantage. Sprinkling with oil is losing favor in Europe, the benefit not being commensurate with the cost and inconveniences entailed. On

MODERN METHODS OF STREET CLEANING

the other hand tar macadam is regarded with much approval.

There is usually a lack of system and method about the whole undertaking of street cleaning in American cities. When a contract for collecting and disposing of house refuse is drawn, few people know what can justly be required or what the work should cost. If the city contemplates doing the work itself the various plans available for final disposal are not sufficiently understood. The possibility of reducing this important work to an orderly and economical system is not known, because there are so few examples of good scavenging. As a rule, contracts are let for too short a time to enable the contractor to feel justified in investing the sum of money necessary for a sufficient plant. The contractor is often suspected of wielding, or being subservient to, political influence. He labors under the disadvantage of attending to what the public regards as the most unpleasant work in the whole city.

CHAPTER IV

THE DISPOSAL OF REFUSE

It should be the aim of every street-cleaning authority to study the character of the wastes produced in his city to the end not only that they may be collected economically, but that they may be turned as far as possible to some useful purpose and compensate in some degree through sale, utilization upon land, hog feeding, or the production of steam power, for the cost of collection. No profitable use can be made of wastes once they become mixed and scattered in the streets. Even horse droppings must be collected instantly to be of service as manure.

The whole theory of economical utilization presupposes that the useful ingredients of city wastes shall be gathered together into relatively large quantities with the smallest expenditure of time and money. It will help to a clearer understanding of this subject if we consider some of the different kinds of material which a city scavenger must handle.

Waste is a term which, in its broadest sense, should be understood to mean something which is parted with by its possessor as not of sufficient value to him to keep. When it is cast away it is converted from private property to public property. Waste, when thrown into the streets, must be removed at public expense and may be utilized and turned to

Theory of
Economical
Utilization

Value of
City Wastes

MODERN METHODS OF STREET CLEANING

such profit as the public authorities see fit. Waste is not necessarily something which is intrinsically useless, but something which, when properly collected and transported to some other locality, may be of considerable value. Papers, bits of metal and glass, bones, scraps of meat, and pieces of cloth, such as are thrown out from every household and cast away by every person, when suitably collected and sorted, may have a commercial value which will more than repay the cost of recovery.

The solid wastes which are collected by public scavengers in small cities are most often disposed of by being dumped in a mixed condition upon low-lying land. In this way extensive marshes have been reclaimed, ravines have been filled and considerable tracts of land have been added to cities.

The Manage-
ment of
Dumps

In spite of strong prejudice to the contrary, there is usually no great sanitary objection to this practice provided the work is well done. As a rule much of the putrescible kitchen slop of small American cities is kept separate at the households and removed by private scavengers who use it for hog feeding, so that the mixed refuse of small cities is not likely to produce offensive odors when dumped on land under proper circumstances. More trouble is likely to occur from the blowing about of loose papers and dust from the dumps. The papers should be burned or buried promptly and the dumps should be leveled constantly. The overhauling of refuse at the dumps for the recovery of useful articles is an insanitary practice which is, unfortunately, well-nigh universal. Often women and children engage in this practice under circumstances which make this

THE DISPOSAL OF REFUSE

occupation demoralizing and degrading in the extreme. If the refuse is to be picked over after it is tipped upon land, the overhauling should be done systematically and under careful supervision.

The dumping place should be well drained and the top should be covered with cultivable earth as the dumping progresses. It is a mistake to suppose that when "made ground" is prepared in this way it is unhealthy. There are dwellings in every large city, built directly upon the top of former refuse heaps where no evidence has ever existed to show that such sites are dangerous. Most of the evils of this system lie in the careless ways in which the dumping is carried on and the dumps maintained.

As cities grow in size, convenient places in which to dump refuse become more and more difficult to find. It is necessary to carry the wastes further and further in order to reach the outskirts of the city. This adds to the length of haul for the refuse carts and long hauls add greatly to the expense.

Refuse is waste, although this term has a somewhat more restricted application than the word waste in practical sanitation, being generally applied to solid matters, whereas wastes may be liquid, solid, or gaseous.

Composition
and Disposition
of Refuse,
Rubbish
and Garbage

The term rubbish is commonly employed, particularly in New York City, to mean that portion of the solid wastes of a household which are most easily inflammable, such as paper, boxes, cardboard, cloth, and straw. Much of this material, when properly sorted, is salable.

Garbage, swill, and slop are terms used interchangeably in the United States for the wastes of kitchens.

Such refuse is not always kept separate from inflammable matters and ashes, but in cities where the so-called reduction process is employed for the final disposition of this class of refuse, and in those places in which any part is fed to hogs, an effort is made by the public scavengers to keep the garbage unmixed with other refuse.

In American houses refuse is generally placed in barrels which are set just outside the houses for the scavenger to empty on his rounds. In cities which have **Private Re-** alleys, the refuse is taken away from the rear, **ceptacles** but in many large cities, as in New York, the refuse is placed in front of the houses to await the scavenger's call. In some foreign cities not only the contents but the receptacle itself is carried away and an empty and clean one is left in its place. This custom is not uncommon among private scavengers in America in dealing with the kitchen refuse of hotels and restaurants. In many English cities the refuse, ashes, sweepings, and garbage are thrown into pits; these are emptied at much longer intervals than might seem sanitary to Americans. For garbage alone, metal receptacles are practically indispensable. House receptacles for refuse are usually too small.

It should be unnecessary to say that the wagons used to haul away refuse should be especially adapted to their work, but it is common to see unsuitable **Wagons and** vehicles employed. The wagons should be **Length of** large, low-bodied, light, tight, covered and **Haul** easily emptied. Dust-proof scavenger wagons are used in many European cities. With the best of these it is possible to empty a barrel of ashes without scattering the dust. This is accomplished by using a wagon

THE DISPOSAL OF REFUSE

whose body is covered completely except for a small opening into which the barrel is raised and emptied by means of an ingenious elevating and tipping device. It is generally economical to use two-horse wagons. Fast walking horses should be given the preference.

To reduce as much as possible the cost of removing refuse in the carts, the length of haul should be as short as possible. In Brooklyn, N. Y., depots are located in central parts of the city and the refuse is taken from these to the suburbs on trolley cars. The removal of refuse on barges is often cheap and convenient when this method of transportation is available.

Where refuse is shot into barges or railroad cars, these dumping places should be enclosed and dust-proof, with special apparatus for ventilation. European experience shows that it is not necessary for a dump of this kind to be a public nuisance.

American garbage has often been chemically analyzed to determine to what extent it can be utilized by the extraction of grease or fertilizing properties, or burnt. The results of these analyses have differed considerably, as might be expected from the fact that food, of which the garbage is the remnants, varies in composition from season to season and even in different parts of the same city. When kept separate from other refuse, the garbage of an American city is believed to contain about three per cent by weight of grease which can be extracted by the process known as **Garbage Reduction** and sold for about three and one-half cents a pound. In other words, the grease in one ton of garbage is worth about two dollars. The other ingredients are worth a little as a basis for fertilizer. Reduction works are almost always owned and operated by private com-

panies which receive annual payments of money for their service. Reliable information is not available concerning the profits.

Raw garbage is practically useless for fertilizer. It should be first composted or rotted somewhat as we rot stable manure; but this is an undiscovered art in America. Composting is done in a large and scientific way in Europe, especially at Amsterdam.

Use of City
Wastes as
Fertilizer

It is impossible to burn raw garbage unless it is mixed with something of better fuel value or deprived of its excessive moisture.

Burning as
a Means of
Final Dispo-
sition

The mixed refuse of houses can be burned in special furnaces, and the so-called rubbish can be burned, often to good sanitary advantage. The aim should be to produce high temperatures, 1000° to 2000° F., and utilize the heat for the production of steam power. In England it has been found possible to evaporate from 1.5 to 2.5 pounds of water from 1 pound of mixed refuse containing garbage, rubbish, ashes, etc. All the principal features of the best plants are patented. So far, few or no good furnaces have been built in the United States. Most of the destructors constructed have been extremely crude affairs and expensive to operate. There is no apparent reason why refuse furnaces should not be more widely used in America. Skill both in design and operation are required for successful results. There is always some odor in the immediate vicinity of these plants; if they are not carefully built and managed they may cause widespread offense.

Incineration, or burning, is a better process than reduction from a sanitary standpoint, since it mineralizes

THE DISPOSAL OF REFUSE

practically all the refuse. It must be remembered, however, that it produces clinker to the extent of one-half the original bulk of refuse, and that this must be disposed of. Sometimes the clinker can be utilized by substituting it for sand in making mortar and concrete blocks. Often it can only be used for filling low land. Refuse furnaces are common in some parts of Europe, particularly in England, but reduction works are practically unknown abroad.

Some cities situated by the sea carry the refuse of their houses and streets to sea and there dump it overboard. There is no objection to this proceeding if the point selected is far enough from **Sea Dumping** land and the barges do not produce a nuisance going in and out of the harbor, two requirements which are rarely fulfilled in practice. Sometimes fragments of the refuse float ashore and cause annoyance. Barrels and boxes, corks, bottles, and the remains of fruit and vegetables are likely to come ashore. Lumps of grease and the dead bodies of small animals are the most offensive portions. When the garbage of New York City is dumped at sea, it fouls the beaches for a distance of from fifty to seventy-five miles. After being dumped this garbage has been observed to move through the water in masses at the rate of nearly two miles an hour, under the influence of a moderate wind.

The term ashes means, as a rule, simply ashes and cinders of coal and wood, although garbage, refuse, and broken bricks and even earth may be, in some measure, mixed with it. This material is **Utilization of Ashes and Clinker** useful chiefly for raising the level of low-lying land. Ashes produced in steam-raising plants may be useful for making cement, mortar, paving-slabs, etc.

Ashes from steam plants are best collected in a moistened condition.

The term cinder and clinker are rarely used in American cities and generally signify the solid residue from the combustion of fuel.

The term dust, commonly employed in Great Britain to mean what Americans understand by the word refuse, may consist of street sweepings and mixed household and trade refuse. To Americans the term dust means finely divided refuse of any kind, so long as it is in a dry state and capable of being carried through the air in the form of fine particles. Dust is most easily handled by first wetting it, as explained elsewhere. It should and can be largely prevented from becoming distributed over the surface of the pavements.

**The Handling
of Dust and
Dirt**

Dirt is a term of the widest application in sanitary science, but in scavenging it is generally employed to mean earth or material resembling it. When dirt is wet it becomes mud; when dry and agitated by the wind it is dust. Street dirt is easiest to remove from pavements when slightly damp, provided it is present in large quantities or in masses. When present in small quantities and widely distributed, it is most easily removed when thoroughly wet. It is most difficult to remove when of the consistency of putty.

Cellar dirt is a term officially employed in New York City to mean earth and bricks, spent mortar, and miscellaneous refuse originating chiefly from the construction and demolition of houses. It is useful for raising the level of low-lying lands, but in New York most of it is barged out to sea and dumped.

Street sweepings is refuse collected from the streets

DISPOSAL OF REFUSE

usually by means of brooms. It consists not only of refuse which has originated from vehicular and other travel, but contains sweepings from the floors of houses, ashes, refuse, and other wastes. Street sweepings are of little use except to fill up low land. In some cases street sweepings have been washed in tanks and the sand and gravel recovered, but this is usually an unprofitable undertaking.

Dead animals are collected and used by private corporations for the recovery of the hides, hoofs, bones, grease, and other saleable parts. They are taken from the streets at public expense, usually by special contract.

CHAPTER V

SUMMARY OF EUROPEAN METHODS OF STREET CLEANING

IN considering the methods by which streets are cleaned, it is necessary to remember that street refuse is divisible into two general classes.

In the first class are (*a*) comparatively large, separate and scattered articles and (*b*) more or less large accumulations of small particles. In the first class are newspapers, fruit skins, horse droppings, refuse from overflowing and overturned garbage barrels and similar matter. In the second class is dirt which is in such a finely divided condition that the individual particles of which it is composed are scarcely visible, if visible at all. At one time this dirt is dust and at another mud, according to the amount of moisture which it contains.

It is obvious that unless promptly removed the dirt included in the first class becomes scattered and pulverized and takes the form of the refuse in the second group. It is highly important, therefore, in protecting streets against unnecessary soiling to remove the large particles as soon as practical after they appear upon the pavement. Better still, they should be kept off the pavements. In European cities pains are generally taken to remove the coarse litter promptly, but the idea of preventing the needless littering of streets with large objects is not everywhere insisted upon as rigorously as it should be.

Wherever the streets of European cities are well cleaned the pavements are in good repair. It is recognized by the authorities that not only is the cost of cleaning dependent upon the condition of the pavements, but it is appreciated that it is quite impossible to keep bad pavements clean.

Character
and Condition
of Repair of
Pavements

The nature of the pavements has much to do with the way in which they are cleansed. In practically all cities, a considerable use is made of asphalt in the busiest streets. Asphalt is regarded with the greatest favor where there is much light traffic and where pedestrians must occupy the carriageways either because they are crowded from the sidewalks, as is frequently the case, or for other reasons.

Asphalt is considered to be the easiest pavement to clean, but requires the largest amount of cleaning to keep it looking well. There is little asphalt in such poor repair as is common on some of the principal streets of New York.

Wood pavement, composed of soft wood, is much employed in England and, to some extent, in Paris, but wood is not as popular as asphalt or stone. Wood is used extensively in the city of Westminster, one of the component municipalities of London. Hard-wood pavements are less popular.

Where wooden pavements existed in 1907 they were generally in excellent condition. The Avenue de l'Opera in Paris was a notable exception to this rule. The defects in the pavement of the Avenue de l'Opera, one of the most frequented and fashionable highways in the city, consisted in innumerable small depressions; these hindered the work of cleaning and interfered with the smooth running of vehicles.

There is much to be said for and against the use of wood pavement, the preponderance of choice being against it in the foreign cities in which my observations were made. In Paris about twelve per cent of the total area of paved streets is wood. The difficulties connected with cleaning wood are like those with asphalt, but they are not so easy to keep in good repair.

Stone, including granite blocks, is more often used than any other kind of pavement, excepting in places where there is a great deal of light traffic. The stone pavements are generally laid and maintained with much care and are thought highly of on every account except noise. They are considered to be the best pavements for heavy vehicles. With the employment of rubber tires on light vehicles, the objection from noise has been partly overcome.

Macadam is used on some important streets even in the center of London and Paris, and to a small extent in some lesser cities. It is, however, confined chiefly to broad highways on which the traffic is not excessively heavy. Paris has about half as much macadam as wood, its use being especially appropriate in the broad boulevards and large open spaces. The macadam is sometimes treated with preparations to keep down the dust and protect the surfaces. Some pavements in Paris treated in this way resembled asphalt. It is generally considered that macadam is the most expensive of all pavements to keep clean.

In Berlin, one of the most modern and enterprising of cities in everything which has to do with municipal improvement, for every square yard of wood there are twenty-four square yards of asphalt and thirty-seven square yards of stone.

EUROPEAN METHODS OF STREET CLEANING

A decided difference exists in different cities in the ways in which it is intended to accomplish the same results in street cleaning. Where in one city the work is chiefly done by hand labor, in another much use is made of apparatus operated by horses or by steam. The reasons for this are not readily apparent.

General Observations

The explanation appears to be that, until recently, little or no attempt has been made to standardize the methods. Each city in Europe, as in America, has developed its own ways of cleaning streets without much reference to the experience of others, and, once committed to a given system, radical alteration or improvement has been slow. It is not that the streets or traffic differ so materially in different cities, but that the customary ways of cleaning the streets have become somewhat fixed that these differences continue to exist.

My opinion is that the best results probably could be produced in any city by a judicious combination of the methods used in many cities. For example, the copious use of water and the highly intelligent application of it in the city of London make street-flushing operations by means of hose more effective there than elsewhere.

The sanding of streets in damp weather was a general procedure, but was done so well in Hamburg that it seemed curious other cities did not follow this method in detail.

The cleaning of sidewalks and the flushing of gutters received such careful attention in Paris that this plan had in it much to recommend it, at least for cities which have enough water and in which no gutter flushing or sidewalk cleaning is practiced.

MODERN METHODS OF STREET CLEANING

Street sprinkling to keep down the dust was practiced in many cities and particularly well in Westminster. The discriminating way in which water is employed in Westminster amid a densely congested and rapidly moving street traffic illustrates some of the higher possibilities in the direction of sprinkling, gutter flushing, and washing with hose.

A prompt collection of refuse, such as horse droppings and papers, in order to protect the street against unnecessary distribution of litter was skilfully done in many cities, but best in the city of London. In parts of all cities this plan is applied through the day, and there was scarcely one large city visited which did not afford examples of the proficiency with which this work can be performed. The peculiar merit of the London system lies in the fact that the orderlies who do this work are young, agile, and numerous, and remove the refuse with the utmost possible dispatch in greatly congested thoroughfares.

I found that it was usual in the greatest cities for the heads of street cleaning departments to be engineers. These chiefs were not uncommonly men who had had considerable experience in this class of work.

The cleaning and removing of refuse from the streets is recognized to be one of first importance among municipal sanitary undertakings and a proper performance of the work of managing a street-cleaning department is considered to require thorough competence and a long training.

The street-cleaning department is often a branch of a larger department which has charge of the construction and repair of all structures between the house lines.

It is this authority which lays the pavements or specifies how they shall be laid and lets the work by contract. It issues permits for opening pavements when openings must be made. It constructs the sewers and lays all pipes and conduits beneath the streets, or, at least, has control of this work.

In the city of London the control of street conditions by the central authority is so complete that it includes not only street cleaning and refuse removal, but the construction and maintenance of sewers, sidewalks, pavements, fire hydrants, public comfort stations, subways for purposes other than passenger transportation, lighting, the removal of dangerous structures, the erection of scaffolds for building purposes, and even the care of public clocks. This authority is called the Public Health Department and the work is done under the direction of an engineer of high standing. In other large cities the control of various matters which have to do with the condition of the streets is also much centralized.

It seems unnecessary to point out the advantages which accrue from this centralization. The plan is worthy of careful study in America, where responsibility is so much divided and where active coöperation between different spheres of authority is so difficult to obtain.

If the great cities of Europe are cleaner than the great cities of America, it is due largely to the quality of the labor employed. Much depends upon the capacity of the ultimate personal unit.

Labor

In Germany the streets are cleaned by Germans; in France by Frenchmen; in England by Englishmen; in America by Italians, Irishmen, negroes, and often by persons who have lost caste in every community.

A marked personal interest is taken by the average street-cleaner in Europe. He receives less money for his services and owes his position less to political influence than is the case in the United States. He takes pride in his work and is not above it. He may spend his whole life in this employment and have no other ambition than to rise to a position of trust in the organization he belongs to. The difference in the cost and efficiency of labor has much to do with the cost of keeping streets clean, for hand work is and must always be one of the chief items of expense of public scavenging.

Considerable difference exists in different cities concerning the organization of the forces engaged in cleaning the streets, particularly as to the number of men employed and the extent to which military discipline prevails among them. In German cities it is the rule to employ workmen who have done military duty and in most places none but men of good physique and energy are used. In some other countries it is evident that much less care is exercised with regard to the physical qualifications of the workmen; occasionally men can be seen who are superannuated and in other ways incapable. In a few small places on the continent, women take part in the work of street cleaning, but the employment of women for this kind of work is strongly opposed to prevailing tendencies. An effort is being made to substitute machine labor for hand labor for reasons both of speed and economy.

So far as could be learned, in all cases responsibility is assigned in the street forces very much as in military organizations. At the head is a superintendent who has officers under him upon whom he can rely for

a prompt and competent execution of his orders. These officers are in turn above foremen and working foremen who come in close touch with the actual day and night work. It was pleasing to see that there was frequently not only a great deal of *esprit de corps* among the men, but that the individuals frequently took great pride in the cleanliness of the pavements entrusted to their care.

It is customary for the workmen of the street-cleaning department in large cities to wear uniforms, but these are invariably quiet and inconspicuous, as compared with those in New York which were purposely designed by their inventor, Colonel Waring, to be as conspicuous as possible.

In the cities which have the cleanest streets there are usually two divisions of the work of cleaning—day and night work. The efforts in the day-
Methods of
Street Clean-
ing
time are usually directed chiefly toward removing refuse which, when scattered about, make streets appear disordered and dirty. The work of more careful cleansing is done at night.

There are here, it is to be noted, two distinct undertakings: The rapid collection of relatively coarse material in the daytime and the slower process of removing finer mud- and dust-producing material at night.

The day work is accomplished chiefly by orderlies and single sweepers assigned to regular posts or beats. The orderlies confine their attention chiefly to removing horse droppings and papers before they become scattered. The sweepers act under general instructions which give them much latitude as to their operations. On the advent of rain or other circum-

stances producing a change in the condition of the streets, they may shift from one undertaking to another. Thus a workman may leave sweeping for sanding, or, in case of snow, may set aside other duties temporarily to put salt on the carriageways.

The orderlies are generally provided with short-handled brooms and scoops and either have hand-carts or are in close proximity to places for the temporary storage of the refuse which they remove from the pavements.

The night work consists in watering the streets and then either (a) sweeping them with horse brooms or horse-propelled squeegees, or (b) flushing them with a stream from a hose accompanied by work with hand brooms or squeegees. The best results, but the slowest and most expensive, are obtained with hand hose and squeegees.

In every case the cleaning begins with a thorough sprinkling of the streets—in some cities this covers the sidewalks. In Paris the preliminary wetting is followed by sweeping with a rotary broom and in many cases by squeegees propelled by horses. Rotary brooms, and rotary or fixed rubber squeegees hauled by horses are much used in nearly all cities.

The throw of the brooms and squeegees is, in most cases, pushed by hand brooms or squeegees into piles and left for collecting carts to remove.

In Paris, much street dirt is flushed into the sewers. The sewers of Paris are unprovided with catch basins, and when built were intended to be sufficiently capacious to carry off all the refuse which might get into them. In other cities much of the finely comminuted street refuse goes to the sewers also, but some of it is caught by catch basins.

Gutter flushing is commonly practiced. It is carried as far in Paris as it probably will ever be possible to carry it in any city. The flow of water through the gutters to the sewers is so large and continuous that minute water plants frequently grow upon the wood paving close to the curb, streaking it green. There seems to be little trouble from street dirt in sewers. Still, the practice of removing as much of the dirt as possible from the streets with horse brooms is considered a wise procedure when there is much dirt to be dealt with.

In parts of London water carts are arranged to discharge a stream of water upon the pavement toward the gutter as the cart is driven along the curb. This plan of gutter flushing is fairly effective and costs little.

Much can be said in favor of an abundant flushing of gutters. A good deal of fine refuse from the carriageways and sidewalks naturally accumulates in this place and can easily be carried away to the sewers when the gutters are flushed and swept. The custom of flushing gutters exists generally throughout Europe in cities of every size, but Paris makes the most use of it. The streets are flushed every night in the city of London except when the weather is so cold that ice might form. The hydrants are about 120 feet apart and sunk beneath the sidewalk.

Flushing by means of hose is carried on in the same general way wherever practiced. The nozzle used is generally circular in form and about $\frac{3}{4}$ of an inch in diameter. It is often provided with a deflector by which the shape and force of the stream can be regulated. The hose is made of rubber or leather, often $2\frac{1}{2}$ inches in diameter, and 50 feet to 200 feet in length. In the

city of London the discharge at the nozzle averages $80\frac{1}{2}$ imperial gallons per minute. Much skill is used in handling the hose and the man at the nozzle receives more pay than the other workmen of his grade.

The stream is always directed well ahead and straight toward the material to be removed, the idea being to use the water less to lubricate than to sweep the dirt away. The lubrication is always very thorough and was done by sprinkling carts in advance. This preliminary wetting or flooding is in reality the secret of the art of successful flushing.

Where the pavement is not perfectly smooth or economy has to be practiced in the use of the water, the flushing is assisted by men with brooms and squeegees. One man at the nozzle and two with squeegees can clean a mile of asphalt or wood pavement in about five hours. In the city of London on streets which are flushed every night the work is much more rapid.

As the methods of street cleaning differ in different cities, so there is great diversity among the types of apparatus employed.

**Plant and
Equipment
Employed**

No automatic flushing-machines seem to be used. Motor-propelled water wagons of large capacity are in use in London and Berlin. The best forms of apparatus for street cleaning are, aside from the motors, simple in construction and designed with careful regard to convenience, efficiency, and durability.

In Antwerp there is a machine which sprinkles the street, sweeps it, picks up the refuse and carries it away. Considering the unavoidably complicated nature of this machine and its weight, it appears to be fairly satisfactory. No mechanical sweepers can, entirely dis-

pense with hand labor. Moreover, they require a fairly smooth pavement to sweep well.

For the work done during the day the workmen are usually supplied with some form of shovel or scoop, a long-handled and short-handled broom and sand-cart. Hand-scrapers, such as are employed in New York, are not much used abroad, the opinion being that the material to be removed should not be pushed over the surface of the pavement any further than necessary, but be taken up and transported otherwise. Nevertheless, there are places where this scraper could be used to advantage.

Some difference of opinion exists concerning the best forms and materials for hand-brooms, the preference in short-handled brooms being, in the main, for a soft bristle which will make a clean sweep, rather than one which is likely to scatter the dirt. Long-handled brooms are usually stiff. One of the most useful tools is a rubber squeegee.

A particularly good hand-cart is used at Hamburg. It is swung low between two wheels, is provided with springs, and is made of metal; it has no cover. This cart is used to carry the tools of the workmen and includes, beside brushes and shovels, a small box of gravel, and a small, short-handled shovel for distributing the gravel. In Westminster, a part of London where particular attention is paid to the care of the streets, the cart used by the day sweepers is large, high, heavy, and unsuitable, and in marked contrast to the convenient Hamburg type. In some cities small carts for street sweepings are hauled by ponies or donkeys.

For the temporary storage of horse droppings and

other refuse from the streets, iron orderly bins have been constructed upon the sidewalks in several cities, notably in London. Their capacity is generally about one-half a cubic yard of refuse; in a special compartment there is storage room for about an eighth of a cubic yard of sand or gravel. On the outside is a basket for fruit skins and other wastes of this kind. These bins are emptied of their refuse as often as required, carts for this purpose sometimes making five or six rounds within twenty-four hours.

Much popular criticism is brought against these iron sidewalk bins on the ground that they impede traffic and are unsightly, and it does seem curious that in cities where fire hydrants, electric wires, lamp-posts, letter-boxes, and other obstructions have been carefully placed under the pavement or otherwise out of the way of pedestrians, these orderly boxes should exist.

In Paris refuse collected from the streets during the day is taken to side streets off the main thoroughfares, and left there until it can be collected by the regular cleaning carts in the morning or, if necessary, by a special service in the late afternoon.

In Berlin experiments are being made on some of the principal streets with pits sunk below the sidewalks and opening by removable iron gates through the curb to the carriage pavement. The refuse is swept directly into these pits by the day workmen. They are emptied at night. A wagon, provided with a crane, raises an iron receptacle from the pit where it has been placed for the purpose of collecting the refuse.

In Hamburg somewhat similar pits are used of a

EUROPEAN METHODS OF STREET CLEANING

capacity of about two cubic yards. They, too, are located beneath the sidewalk, but open at the top through iron doors which lift up. The refuse is dumped into these pits from the hand-carts of the sweepers. The refuse is removed at night by men with shovels who throw it into large carts which make rounds for the purpose. Pits are also used in Glasgow.

Much diversity exists among the forms of carts used to remove street and house refuse. Many are of large capacity, but are often heavy and so high as to be awkward to fill. Moreover, they are generally not covered, so that the refuse is blown from them and scattered by winds and made wet by the rain. Some excellent carts are used on the continent. Among the best are large, low, four-wheeled, metal wagons provided with covers and possessing convenient arrangements for dumping.

The best carts for street sprinkling have high bodies and a control of the sprinkling apparatus which enables the driver to regulate the water so that it will flow to either side. The shower can be varied from an extremely small amount of water to a copious discharge. A prevalent defect lies in the arrangement by which the carts are filled. It sometimes takes half as long to load a cart as to empty it. The fault here is due to too small hydrants. The best water carts are filled through the bottom, have holes of different sizes through which the water passes, are provided with mud pots to protect the holes against clogging and have their sprinklers located behind the rear wheels.

A handsome new motor sprinkler is in use in Berlin. This is capable of throwing water by a centrifugal pumping arrangement to a great distance on either

side. Similar sprinkling devices are often used on municipal street cars in Germany to sprinkle the streets on each side of the tracks.

There is little of special interest about the sweeping-machines. The best practice seems to favor the use of four-wheeled sweepers with springs and arrangements for two horses, although in some of the largest cities, excellent work is done by two-wheeled rotary sweepers with one horse. Practically every large city uses horse-propelled sweepers on some streets.

Horse-propelled squeegees are commonly employed for asphalt and wood, either in combination with sweeping-machines or sprinkling-carts, or separately. A new machine frequently used consists of a watering cart to the rear of which is attached a drum revolving like a rotary sweeper, but provided with rubber squeegees arranged spirally around the drum. This machine is particularly useful on smooth pavements, but seems to offer few advantages over squeegees built like road scrapers. The latter are much cheaper to buy and keep in repair. The horses used in Europe are generally excellent.

Motors are used in several cities, particularly where the pavements are good and the amount of cleaning large. The motors are, for the most part, little else than traction engines fitted at pleasure with removable cart bodies and water tanks with sprinkling apparatus. In most cases interchangeable bodies are provided so that at night the motor can be used for street sprinkling, and in the day for other purposes.

Economy in the use of these motors is considered to depend upon being able to employ them day and night. In this case only are motors cheaper than

horse traction. In London steam is used as motive power to propel one cart and haul two or three others. The city of London has paid between \$3000 and \$4000 each for its motors, and has half a dozen of them in use. One of these seen by me had a capacity for refuse of twelve cubic yards. When used for sprinkling, the water body contained 360 gallons; it could be filled in three minutes and emptied in about twenty minutes. Its weight empty was about thirty hundred-weight.

The material swept from the streets of foreign cities is sometimes turned to advantage, but the principal object is understood to be to get it out of the way. Theoretically of much value as a fertilizer, and possibly of some use as a fuel, the practical difficulties of utilizing street sweepings are too great to make it of substantial use. It is, of course, a mixed refuse and its composition varies in different seasons in different cities and in different parts of the same city.

In Paris, the refuse from the streets is, as far as practicable, swept into the sewers and carried with house drainage to farms or emptied into the River Seine below the city. Some of the sand and other solid matters which are carried by the sewage have to be removed before the sewage is utilized. Were it not that Paris is particularly fortunate in having abundant water and a good sewerage system, it is doubtful if that city's famous plan of emptying so much refuse into the sewers would be satisfactory. It is said that some of the sand washed from the streets of Paris into the sewers is recovered and used on the streets over and over again.

MODERN METHODS OF STREET CLEANING

In many cities horse droppings form the bulk of the refuse collected from the streets and if this material is promptly collected and kept separate from other refuse, it is sometimes salable. The city of London, for example, sells the refuse collected by its street orderlies for about 11 cents per long ton.

In some instances, notably Charlottenburg, miscellaneous street sweepings are used, after a storage of six months or so, as manure upon flower beds in the city parks.

The most usual way to dispose of street dirt is to use it to raise the level of low-lying land. Some difficulty is experienced in this direction, for there is not always suitable land to be filled. Furthermore, unless the refuse contains a large amount of indestructible matter, such as sand, it is not generally considered wholly suitable for this purpose. In many instances where transportation is cheap because of special canal or river facilities, street sweepings are barged away to the country with other city wastes. The barging is sometimes done by contract at so much per ton.

The removal of snow is universally considered to be an unsatisfactory problem to deal with, although it offers much greater difficulties in some cities than in others. In Berlin and in North German cities generally, the winters are severe, and occasionally snow storms occur which compare with some of the worst which are experienced in New York. In Middle France and the Low Countries, the winters are less rigorous. In England and Ireland the winters are mild. Occasionally a year passes without any snow in London except such as melts as it reaches the pavement.

EUROPEAN METHODS OF STREET CLEANING

For the most part the snow is removed by carts somewhat after the method followed in New York City. Use is made of snow ploughs, however, and of small hand-carts in clearing the principal thoroughfares. It is not uncommon to dump the snow in parks and other open spaces until a thaw, when it is carried away or allowed to melt and run into the sewers.

Much use is made of salt. The salt is used to melt the snow as it falls, the object being to prevent an accumulation, rather than to remove the snow after it has become deep.

In London on the approach of a snow storm whether by day or night, the street cleaners, who have been supplied with instructions in advance and only need to exercise a little judgment in knowing when to apply their directions, scatter salt of the color and consistency of coarse sand over the streets. When the snow falls upon this saline bed, it melts and runs to the sewers. If the fall is too rapid or the weather too cold for the snow to melt, and slush is formed, the latter is flushed away into the sewers, with water from a hose and the pavements squeegeed as soon as this is possible. The quantity of salt used for a given area depends upon the depth of snow. In Paris $4\frac{1}{2}$ ounces of salt per square yard have been used for a fall of two inches. This is much more than is used in London. Much snow is emptied into sewers.

An important part of the work of all street-cleaning departments is the removal and disposal of house refuse. It is an almost universal custom to collect this refuse in a mixed condition, but the component parts of the mixture vary in different cities and at different seasons of the year.

The Collec-
tion and
Disposal of
House Refuse

Foreign household refuse is generally quite unlike the American product; there is less kitchen waste, less paper, and apparently less unburned coal.

In only one city, Charlottenburg, did I see a division and separate handling of the house refuse at all comparable with that in New York. In this case the work of collection and disposition was done by contract. In Berlin the custom is directly opposite to that of New York in that the house refuse is collected by contract and delivered to the city for final disposition.

More or less sorting of refuse is done nearly everywhere and in some places to an extreme limit. In Paris, household refuse is sorted by rag-pickers upon the sidewalks, by men and women in the carts which collect the refuse from the houses and at depots in the outskirts of the city where the material is hauled.

In most British cities house refuse is thrown by the householders into private pits where it remains for periods of time ranging from a few days to several months. On the Continent portable cans and boxes are more often used. In some instances the cleaning department furnishes receptacles, carrying them away from the houses when full and returning them empty after they have been cleaned and disinfected.

The methods of final disposition are, in the main, much the same in European cities. Much municipal refuse is used for filling low land. Other portions are used as manure and still other parts are burned. It should be remembered in this connection that a large part of what is properly termed municipal refuse is composed of street sweepings, material taken from privies and cesspools, cinders, and trade wastes which are not readily inflammable.

EUROPEAN METHODS OF STREET CLEANING

It is surprising to note how much household refuse is put upon land in one way or another. Berlin disposes of all its household refuse in this way, as do Amsterdam, the city of London, and many other large and small places. Until very recently, the city of Paris sold all its decomposable house refuse as manure for the cultivation of sugar-beets. The city of Belfast burns only about one-tenth of its municipal refuse, the rest going upon land. Salford burns about half. Manchester owns 3700 acres of rural estates purchased for the sole object of receiving city refuse. Refuse from the city of Glasgow is sold to farmers scattered in fifteen counties in Scotland. All the cities here mentioned, except Berlin, have refuse destructors also.

In Great Britain the destruction of household refuse by burning in special furnaces was begun about thirty years ago and is now generally considered a desirable procedure wherever it can be followed. The sanitary advantages of destroying refuse by burning in this manner are so well known as scarcely to need mention here. Less is known concerning the cost of this method of disposal as compared with utilizing refuse by putting it on land.

When the total cost of burning is considered, the process often appears less economical than is popularly supposed. In fact, counting the cost of repairs, interest on the investment, sinking fund charges, and the wages of the attendants, it not infrequently happens that it would be cheaper for a foreign city to turn the household refuse into manure, and apply it to land.

To partly offset the cost of burning refuse, efforts are usually made to utilize the heat produced to raise

MODERN METHODS OF STREET CLEANING

steam for producing electric light, to pump sewage or water, to operate machines, and for other purposes. The residue is used for many purposes, such as the making of concrete, mortar, bricks, and asphalt pavements.

On reviewing the different subjects thus briefly covered it seems desirable that I should mention particularly a number of points which go far to account for good results in Europe. Most of these points have a general application to American conditions:

Conclusions (1) Centralization of responsibility for the repair and cleaning of street pavements is desirable.

(2) A competent person should be at the head of the street-cleaning department—preferably an engineer experienced in sanitary work.

(3) An organization somewhat military in character is best. But it is unnecessary that the military spirit should be carried beyond the point required to fix responsibility and insure a proper execution of orders.

(4) Good pavements in good repair are indispensable to efficiency and economy in street cleaning.

(5) Asphalt is the easiest pavement to clean, but the hardest to keep looking well because it will not hide dirt.

(6) It is possible to clean streets without the use of water, but the results are only measurably satisfactory in most instances. For the best work there should be sufficient water used to carry off the finer dust by the use of water from a hose preceded by thorough lubrication with water from a sprinkling cart.

(7) Sewers should be used to carry away all street refuse and sand which can be put into them without

EUROPEAN METHODS OF STREET CLEANING

obstructing them or adding seriously to the problems connected with the disposal of the sewage.

(8) Economy demands that refuse be removed as soon as possible after it is produced and unnecessary littering prevented.

CHAPTER VI

LONDON

A STRANGER to London who seeks to understand the system by which this greatest city manages its municipal affairs is likely to become seriously perplexed. He will find that what is termed "London" is, in reality, an aggregation of cities, towns, villages, and parishes spreading out over an immense area.

What is properly called "Greater London" is the Metropolitan Police District, which covers 693 square miles. This district has about 7000 miles of streets and had a population, in 1906, of 7,113,561.

London an
Aggregation
of Cities

What is generally meant by the term "London" is an area of 122 square miles near the heart of the city. It is roughly estimated that this area contains 8000 streets of an aggregate length of about 3000 miles. It has about 600,000 buildings and, in 1906, had a population of 4,721,217. Within the last fifty years the population has nearly doubled and about 2000 miles of new streets have been built. The total annual cost of the government of London is about \$85,000,000.

In the center of this great aggregation lies what is properly termed the "City of London," covering one square mile of territory. It was from this center that the rest of London grew. Suburban settlements sprang



The center of London on a Holiday. The Royal Exchange is to the right and the Bank of London to the left. On week days this place is so crowded with pedestrians and vehicles as to make attempts at photography unsatisfactory.



London—Typical refuse collecting wagon.



Street Orderly Bin and Hand-carts used in street work in background.
Entrance to London Bridge.



Westminster Sand Bin filled for use. Street refuse is shoveled into a
compartment at the top.

LONDON

up and grew to villages, and these in turn became towns and cities. As each grew in population it expanded in size until visible limits and boundaries became lost and the municipalities became confluent. With this kind of growth, without central control or plan, it was natural that the convenience of each unit should have been the only care.

It has well been said by the Advisory Board of Engineers to the Royal Commission on London Traffic, Vol. VII, 1905, that "Streets were planned and laid out with regard only to local needs—without apparent thought of making any new or widened street an extension or component part of a street in an adjoining parish or district, and without considering that a street in a city has not only to fulfil its functions as a local highway, but should also act as a thoroughfare, connecting adjoining districts and that consequently it should be made of such proportions as to bear the double burden of local and through traffic, with ample provision for the increasing demands of the future."

Until comparatively recent times the municipalities in the vicinity of the original city were administered under no less than two hundred separate acts. It was largely in recognition of the need of properly caring for the traffic on the thoroughfares and maintaining the city in a more sanitary condition that a move toward consolidation was made in 1856. This move was the formation of the Metropolitan Board of Works. At this time the sewage of about three million people was being emptied into the Thames in the center of the city, with the result that insufferable odors were produced. The most important work of the Metropolitan Board of Works was

Importance
of Central
Sanitary Au-
thority

the Main Drainage System by which sixty million tons of sewage are carried annually through about 88 miles of main sewers to Barking and Crossness on the Thames, where works have been constructed for the partial purification of the combined street and household sewage. The carrying capacity of these sewers in 1907 was so heavily taxed that overflows took place into the Thames when the rainfall exceeded one-eighth of an inch.

The Metropolitan Board of Works was finally succeeded by the London County Council in 1889 which has jurisdiction, so far as certain sanitary and other matters are concerned, over an area which is called the Administrative County of London. So far as the construction and cleaning of streets are concerned, the various municipal authorities have preserved their separate identity and authority with religious zeal.

The Administrative County of London comprises the following separate municipal bodies: London County Council, Corporation of the City of London, Council of the City of Westminster, and the Metropolitan Borough Councils of Battersea, Bermondsey, Bethnal Green, Camberwell, Chelsea, Deptford, Finsbury, Fulham, Greenwich, Hackney, Hammersmith, Hempstead, Holborn, Islington, Kensington, Lambeth, Lewisham, Paddington, Poplar, St. Marylebone, St. Pancras, Shoreditch, Southwark, Stepney, Stoke Newington, Wandsworth, Woolwich.

Within the limits of "Greater London" are included the foregoing thirty corporations and many other county councils and borough corporations, so that, in the whole of Greater London, there are no less than 106 highway authorities. These are without any cen-

**Multiplicity
of Highway
Authorities**

LONDON

tral authority to advise or guide them or hold them accountable for a proper performance of their important duties. The boundaries between these political areas are irregular and confusing. One side of a street may be in one county and the other side in another.

It is obvious that an account of the methods used in cleaning the streets of all the different administrative sections into which London is divided would be a formidable undertaking. Some of these methods are very crude. Among the best and most representative are those followed in the City of London and the City of Westminster.

That part of the Metropolis which is properly called the "City of London" differs from most other cities in many important particulars. It is, however, to all appearances, a part of the greater city and seems to be identical with it except in government and certain physical peculiarities. It is the commercial heart of the Metropolis. The area covered is one square mile.

The very center of London may be considered to be the Bank of England. The district immediately around the bank is given up to warehouses and offices, while around this center are factories and warehouses. According to the census of 1901 the night population is 26,923, and the day population, based on the number of persons who enter the city regularly through the week to work, is 427,000. There has been a decrease in the last ten years of over 28 per cent in the night population, the ground becoming so valuable for commercial purposes as to prevent its use for dwellings. At the present time there are 13,000 buildings in the city and of these over 5000 are left vacant every night.

MODERN METHODS OF STREET CLEANING

There are about 4000 warehouses, 3600 shops, and 523 manufactories.

The street cleaning is in charge of an engineering bureau of the Public Health Department of the Corporation. This department reports to a **Authority over Street Cleaning** Committee on Improvements and Finance of the Common Council and the Committee in turn reports to the Mayor.

Street cleaning is but one of many lines of work attended to by this Committee, their powers and duties **Scope of Work** giving them supervision over practically all the physical conditions which have to do with the thoroughfares except the regulation of traffic. The subjects which receive their attention include the widening of streets, the laying and repair of pavements, the construction and care of sewers, and supervision of all wires, pipes, and conduits which pass overhead or underground, the care of fire hydrants, street lighting, and the maintenance of public comfort stations.

The engineer has under his orders a superintendent of street cleaning, who has active charge of the work of keeping the thoroughfares clean. The Corporation of London owns its own street-cleaning apparatus, horses, wharf, and refuse destructor. It purchases supplies only by contract or after public advertising.

For the use of water, regular bills are rendered at the rate of about 12 cents per 1000 gallons, the quantities being determined by meters or by special **Cost of Water** inspectors from the Water Board, who mark the time during which the hydrants are turned on and note the circumstances of their use. In the year 1905, about \$22,000 were spent for water, of which about \$10,000 went for water used in washing the surfaces

LONDON

of streets, about \$1500 for watering the streets, and about \$260 for flushing sewers.

The streets of the City of London are often exceedingly crooked and irregular in direction, though well paved and kept in an excellent state of repair. Numerous courts, alleys, and passageways exist. The way to some of these lies through covered entrances. It is illustrative of the completeness of the jurisdiction of the street-cleaning department, as well as of the thoroughness of its work, to state that the walls of about eighty of these entrances are cleaned and some whitewashed twice each year.

Some idea of the extent of the work of the Corporation in keeping the streets clean may be gathered from the fact that over 1,209,000 people and nearly 100,000 carriages enter and leave the city daily, and that out of this number more than 300,000 persons pass the day within the city.

On Cheapside, a street which varies from curb to curb from 32 to 41 feet 10 inches, 1,322 vehicles have been counted passing a given point in one hour and 12,563 have passed from 8 A.M. to 8 P.M.

Practically speaking, the whole city is washed every night by water taken from hydrants or water carts, the main work of cleaning beginning at 8 P.M. (Saturdays and Sundays excepted) and ending at 6:30 A.M. the following morning. The first streets attended to are those in which the traffic practically ceases after 7 P.M., and the last those in which it continues up to a late hour. The men are engaged on these last streets up to 6 o'clock in the morning.

The washing of streets is done in a highly scientific manner with leather hose attached to hydrants. The

nozzle is held by one man while two others manage the hydrants, operate brooms and squeegees, and warn off vehicles with lanterns. The nozzle is $\frac{3}{4}$ inch in diameter. The pressure of water is 60-80 pounds per square inch at the hydrants.

Special attention is given to streets in the vicinity of markets where business is resumed at an early hour and where the difficulties of street cleaning are greatest. In the neighborhood of Billingsgate fish market the streets must be thoroughly cleansed, the catch basins flushed or emptied and disinfected, street dirt removed, and the pavements gravelled soon after midnight, so that the garden produce shall lose no time in reaching its destination through bad travelling. Little can be done here in the daytime owing to the excessive congestion of vehicles and pedestrians. The market opens at 5 A.M.

A removal of house refuse from all premises in London at least once each week was made compulsory by a by-law of the County Council in 1893. This led to systematic scavenging in those parts of the Metropolis where it did not exist already, in place of the old plan whereby dustmen perambulated the streets and removed the refuse on the application of the occupiers of houses.

Difficulty is experienced in some sections in collecting the refuse through the unwillingness of householders to permit collection, the number of these refusals in Hackney alone amounting in 1905 to some five or six thousand per week. It is to be expected that this trouble can be overcome, for refusal constitutes obstruction, and for this a penalty can be enforced.

LONDON

In many parts of London house refuse is collected much more often than once a week. More frequent collections are needed in districts occupied by flats and tenements where gas is used for fuel, for here no opportunity exists for burning any of the refuse and it accumulates without the dessicating and preserving advantage of ashes.

In Holburn the refuse is removed from houses by contractors twice a week from April to October inclusive and once a week during the rest of the year. In parts of Finsbury, the City of London and Westminster, daily collections are made.

A by-law of the London County Council provides that when a sanitary authority arranges for the daily removal of house refuse, the householders may be required to deposit their receptacles for refuse, at such hour as the authority may fix, on the curbstone or in a conveniently accessible position on the premises.

Under ordinary conditions of weather the cleansing of streets with water progresses in a favorable manner, but in the winter months when there is possibility of frost, great care is taken to prevent the production of ice and frequently street flushing is entirely suspended. In 1905 the streets were washed on 296 nights.

Showery weather also makes the streets slippery and necessitates the use of grit on the pavements. The nature and amount of grit used on roadways to prevent slipping depends upon the nature of the pavement and the grade of the street. On asphalt very fine sand is employed, the amount being about 80 cubic yards per 1000 square yards of pavement per annum. This sand costs about \$1.00 per cubic yard at the city docks. On wood and stone-

Sanding of
Pavements

MODERN METHODS OF STREET CLEANING

block pavement the ballast used is slightly less in quantity and the particles average $\frac{3}{8}$ inch in diameter. To prepare it for use on the streets the gravel is washed and freed from foreign matters. It is supplied by a contractor at about \$1.25 at the city wharves on the Thames.

It has been found that large quantities of grit and other refuse interfere with the cleaning operations which go on at night, for it clings to the pavements and can be removed only by water supplied in force by means of a stream from a hose. To meet this difficulty an additional gang of flushers is occasionally requisitioned after midnight to flush certain streets which otherwise would have been cleansed by water and squeegees.

The night cleaning occurs through the week until Saturday. From Saturday midnight to 9 A.M. Sunday about three-fourths of the night staff are engaged in sweeping the streets and removing the refuse collected together by hand and machine brooms, thus leaving the city clean for Sunday. In summer, however, most of the asphalt streets are watered by watering-carts and then squeegeed. On Sunday the night flushers are engaged in washing main streets and courts which receive more than an ordinary amount of refuse and those which are named by the Medical Officer of Health of the Corporation.

Cleansing of
Courts The cleansing of courts is an important feature of the work of the street-cleaning force. The term court, it may be mentioned, includes lanes, alleys, passages, and some less important side streets, as well as small squares and yards, of all of which London has numerous examples. Some of these courts



Street Crossing. Sweeper near the Houses of Parliament, London. The pavement is macadam.



Westminster on a Wet Day. The streets where not flushed are covered with greasy mud.



London, Westminster.—Collection of Rubbish, Covent Garden Market.

LONDON

are washed from once to six times a week during the summer months. The season when most of the flushing is done begins in June and ends in September. In 1905, the quantity of water used to cleanse the streets and courts was about 96,000,000 gallons and cost about \$9720.

From 10 A.M. to 4:30 P.M. day sweepers are engaged in keeping the main streets and most of the secondary streets clean, using for this purpose hand brooms during dry weather and squeegees when the weather is wet. When the street dirt is too wet to sweep and too dry to squeegee, it is either made more wet with sprinkling-carts and removed by squeegees, or scrapers are employed.

From June to September, inclusive, most of the catch basins are disinfected once a week, but in many places they are disinfected every day. In the streets around Billingsgate fish market Catch Basins they are disinfected three times a day in summer.

Each day from 7:30 A.M. to 5 P.M. in summer and 4:30 P.M. in winter about 200 orderly boys are employed on the main streets in sweeping up horse droppings, spreading grit upon the Work of Orderlies pavements and in wet weather squeegeeing the sidewalks. From 5 P.M. to 7:30 P.M. in summer and from 4:30 P.M. to 7:00 P.M. in winter about 50 boys, assisted by a few sweepers, are kept at work on the main streets. The agility and skill of these boys are remarkable. Using a scoop resembling a short-handled shovel with an inverted handle and a short broom, a boy can pick up the fresh droppings of a horse in less than ten seconds.

The area of street pavement which an orderly boy

MODERN METHODS OF STREET CLEANING

can attend to depends upon many local circumstances, including the character of the pavement, its condition of repair, the state of the weather, and the amount of vehicular travel. In one of the busiest places, Cheap-side, a boy of 16 years, earning \$3.50 per week will take care of 1200 square yards of roadway. In other districts where the travel is less heavy a boy can take care of 20,000 square yards of pavement. The horse droppings are thrown into iron bins on the sidewalk, or in the center of the carriageway, and these bins are finally emptied by men into high carts and taken to barges on the river front. The boys wear white coats and black caps.

On Sundays a few men and boys are engaged on the main streets from 11 A.M. to 7 P.M. clearing up litter, spreading grit or squeegeeing as required. Water carts are at work on Sundays, also, during the summer months, from 10 A.M. to 4 P.M. as required. On holidays a number of men and boys are engaged for a few hours in the morning on main streets to remove refuse, to squeegee or to spread grit as required.

Snow is removed as far as practicable by the use of salt. Common rock salt, of a brownish color, resembling coarse sand, is stored in bins at convenient points along the streets and is sprinkled on the streets like gravel on the approach of snow. When the snow falls, it rapidly melts on this saline bed and runs off to the sewers. If the snow continues to fall for a long time and does not melt promptly, more salt is used, until the mass becomes a sloppy, semi-liquid compound which can be flushed into the sewers with a hose. Only rarely is it necessary to resort to carts to haul the snow away. In

Removal of
Snow

LONDON

1905 there was so little snow that no special attention had to be paid to it. It is estimated that one ton of rock salt is enough for 16,000 square yards of roadway per six inches of snow.

The quantity of solid matters washed into the sewers is comparatively slight. In 1905 there were removed 113 yards of sand and similar material.

The Corporation makes use of several self-propelled vehicles to assist in removing refuse from the houses and streets and for sprinkling the streets preparatory to flushing them. Up to 1906, Self-propelled Vehicles six of these motors, operated by steam, had been purchased at \$3000 and \$3750 each. They removed about 38 long tons of refuse each week.

House refuse is removed by carts which make their rounds for that purpose in the morning. The refuse is placed by householders in tubs and boxes at the edge of the sidewalk not later than 8 A.M. each day and many streets are entirely cleared in the following hour.

The refuse from houses was until the year 1905 taken to a destructor situated at Letts wharf. This plant consisted of ten cells of the Fryer type built in 1884. It was fed at the top and stoked at a lower level. Disposal of House Refuse It was put out of service because of bad condition and the extensive repairs necessary, the street committee, in view of the cost of these repairs, finding it would be more economical to discontinue the use of the destructor and barge the refuse away. The cost of barging was about 43 cents per long ton.

Trade refuse is collected by the city, but is charged for when the quantity is considerable.

The quantities of street and house refuse removed

MODERN METHODS OF STREET CLEANING

vary very slightly from year to year. In the ten years, 1896-1905, the volume of street sweepings and slop increased less than 7 per cent, and in the four years, 1902-1905, only about 2 per cent. In the ten years' period mentioned the volume of house and trade refuse increased less than 20 per cent and in the four-year period about 6 per cent. In 1905 the quantities were: 51,572 loads of house and trade refuse and 31,915 loads of street sweepings and slop, making a total of 83,442 loads, or about 267 per day during the six days in the week.

The total number of employees in the service of the street-cleaning department in 1905 was 727, including 94 attendants at public comfort stations.

Personnel

There were 208 sweepers, 193 orderly boys, 105 cartmen, 17 motor drivers and assistants, 18 flushers, and 12 sewer men, making a force of 553 engaged on the streets. Over the whole force there are 13 foremen.

The employees are of all ages from the orderly boys of 16 or 18 years to men of 70 and even 80 years or more. The average age of the 15 employees who were in receipt of sick allowances at the end of 1905, was 65. Of seven others who died the average age was 48.

CHAPTER VII

WESTMINSTER, LONDON

THE city of Westminster comprises 25,027 acres of the most fashionable and busiest part of London. It extends about $3\frac{1}{4}$ miles in one direction by $2\frac{3}{4}$ miles in another and has 99 miles of streets. It includes the Strand, Charing Cross, and the principal shopping districts in the vicinity of Regent Street and takes in the aristocratic West End with Buckingham Palace and the leading theaters. Finally, to add diversity to the conditions, Covent Garden Market, one of the largest markets in London, is included in the boundaries. Unlike most of London, the surface of the ground is not level, but slopes with considerable gradients in places covered by principal thoroughfares. These gradients have had much to do with the use of wood pavements, Westminster offering one of the best illustrations in Europe of the successful employment of wood for streets with heavy traffic. The population of Westminster, according to the census of 1901, was 183,011.

The street-cleaning authority in the city of Westminster is vested in a committee of the City Council known as the Highways Committee. This committee has charge of the maintenance, as well as the cleaning of the carriage roads, and by agreement cleans also the sidewalks. The following matters are included in the work of the High-

Authority
over Street
Cleaning

MODERN METHODS OF STREET CLEANING

ways Committee: The cleansing of sewers, gutters, etc.; the cleansing and watering of streets and highways, including the sidewalks; the sanding of roads; the removal of snow; the collection, removal, and disposal of street and house refuse; the provision, maintenance, and control of land, wharves, depots, destructors, and other buildings required for cleaning purposes and also for all wagons, carts, motors, and other plant, stables and horses, and the equipment required for cleaning or for the Works Department.

The city is divided for the purposes of the department into seven districts, designated by letters of the alphabet. Each district is under the supervision, from 6 A.M. to 5:30 P.M., of a district foreman. In addition, a special foreman supervises from 9 A.M. to 10 P.M. the scavenging of Covent Garden market.

Each foreman has under his charge the sweepers allotted to him, each sweeper bearing his service number and district letter in brass upon his cap. The foreman is responsible also for the carmen and dustmen working in his district. Each foreman is required to make out in writing a daily report on the work of his district, and this is examined by a day traveling ganger. The latter visits the City Hall every day at 9:30 A.M. to report to and to be interviewed by the assistant superintendent of the Highways Department and to hand in special reports where required of the complaints received. Should any unusual occurrence arise in the district, a special report is made out by the foreman to cover it.

Daily and special reports and returns are also made out in writing by weigh clerks and the keepers of

the four stables maintained by the Committee. All reports are submitted at the City Hall for examination by the assistant superintendent of the Highways Department and are then taken to the deputy engineer of the Highways Department who has charge of street cleaning.

The total amount of street and market refuse collected during the year 1905-1906 was 59,633 tons. This refuse was carted to barges situated at convenient points on the Thames and carried away by contract. The contract price for barging away this refuse was 27 cents per ton of 2240 pounds.

One of the most distinctive processes of street cleaning is flushing. The flushing is done with fire hose at night from 11:30 P.M. to 9:30 A.M. There are eighteen flushers and many sweepers acting under the flushers. The flushers in turn act under three flushing foremen and these foremen are under the supervision of a night traveling ganger. The ganger also supervises the work of collecting that part of the refuse which is carried away at night. His reports are made in the same way as described for the day traveling ganger already mentioned. The flushing staff has its chief center at a depot at Du Fours Place. Some of the flushing plant is also stored there. Messroom accommodations are provided at five sub-stations. The night staff is divided into gangs, each consisting of one leading flusher and two sweepers called assistant flushers. Each gang is provided with hose, truck, and two truck lamps and a complement of 2½-inch leather hose of four lengths of 40 feet each, tools for cleaning out catch basins, squeegees, broom, hydrant-connection branch pipes, ¾-inch nozzles, T-keys and tubes. In connec-

Method of
Street
Flushing

tion with the flushing of street surfaces a number of watering-carts with horses and four motor water wagons are used to thoroughly water the surfaces of the streets to be flushed.

The water is obtained for the most part through metered hydrants placed below the surface of the sidewalks. Otherwise the water is supplied by a turncock who accompanies the flushers by previous arrangement with the Metropolitan Water Board. The time occupied in flushing with each $\frac{3}{4}$ -inch nozzle is recorded by the turncock and charged for at the rate of \$1.25 per hour. Since 1902 meters have been placed in connection with many of the hydrants, the price charged for the water being about 12 cents per thousand gallons. At the present time there are about 612 metered hydrants in use. The streets are flushed from once to six times per week, depending upon the amount of vehicular travel.

No flushing is carried on when the temperature is lower than 36° F., or when the condition of the street surface renders the work manifestly unnecessary or undesirable.

When not engaged in flushing or cleansing with water the night staff with horse-sweeping machines and sweeping machines attached to motors are engaged in cleaning thoroughfares. No Sunday flushing is done after 8 o'clock A.M.

The scattering of sand upon the street to prevent slipping is carried on between 5:30 and 8 P.M. by men especially suited to this duty. They are supervised by four foremen who, for the control of this work, have their districts planned so that all of the streets which are sanded are divided

Sanding of
Pavements

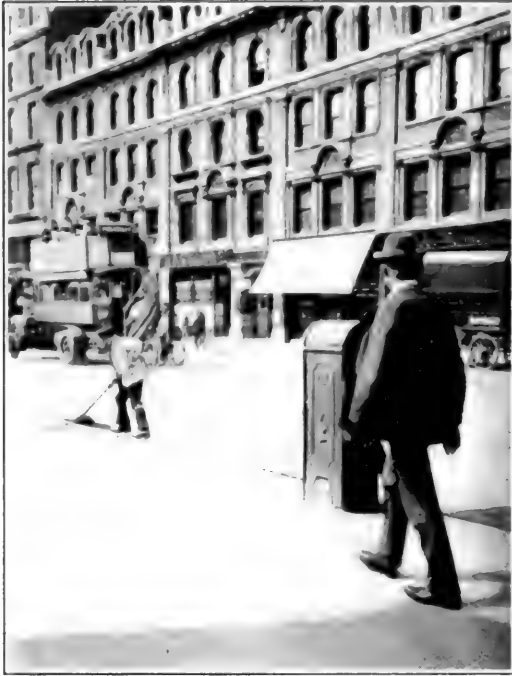

City of London—Street orderly and orderly bin.



City of Westminster. Orderly with hand-cart—Piccadilly.



London.—Motor Water Wagons used for watering streets preliminary to flushing.

WESTMINSTER, LONDON

into four divisions. In bad weather each foreman is responsible for his district up to 10 P.M., after which hour responsibility rests with the flushing foremen. This responsibility is not great except during snowfalls. Foremen of both grades are paid at overtime rates. Granite chippings are used in place of gravel on asphalt roadbeds. This ballast is distributed rapidly by the sweepers from orderly trucks with ordinary short-handled ovels or, on special occasions, by distributing machines. One pint of ballast per 1000 square feet of pavement has been found to give good results on a moderate grade.

The removal of house and trade refuse is carried on in accordance with the Public Health Act of 1891, which requires that house refuse shall be removed Removal of House Refuse not less frequently than once a week. This weekly system of refuse collection obtains for the most part except in localities or streets in which a daily collection has been arranged.

Where there is a weekly collection the refuse is removed from ash pits. This work entails the use of baskets and shovels and much labor on the part of the workmen.

Where there is a daily collection the occupier of the premises is required to place the refuse in receptacles at a fixed hour on the street or some other convenient place agreed on, so that the labor of the collectors is reduced and the time of the horses and plant economized as far as practicable.

For the purpose of removing the house refuse, the city is divided into two areas, from one of which the refuse is removed by the city and from the other by contractors. The contract area is divided into three dis-

MODERN METHODS OF STREET CLEANING

tricts, each of which is let to separate contractors. The area cleaned by city labor comprises the most thickly populated portions of Westminster and nearly all the small business houses, while two of the three divisions of the contract work contains the best residences of the city where many of the houses are occupied for only a portion of the year. A comparison of the cost of the two systems of work is shown in the following table:

	1905-6	1906-7	
By contract	\$2.82	\$2.09	} per holding
By direct labor	3.55	3.45	

There are 17,377 premises from which refuse is collected by contract and 27,486 from which refuse is collected by city labor. The cost of the removal of house refuse by contract is \$38,175.30. The total tonnage removed by the city laborers for the year 1906-7 was estimated at 55,700 tons of 2240 pounds each. Taking an average of three yards to a ton and reckoning the cost of removal at about 56 cents per yard, this amounts to a total of, say, \$94,740.84 per annum for the total cost of collection and disposal of the house refuse collected from the area where city labor is employed.

Each district foreman where city labor is employed is responsible for the removal of refuse, and for this purpose the whole city is divided into two parts each under the supervision of a refuse inspector. Complaints and similar matters concerning the service are dealt with directly through the City Hall. The refuse inspectors visit the office twice daily to deal with these questions, at 9:30 in the morning, and again in the

WESTMINSTER, LONDON

afternoon. The contractor's foremen are also required to visit the office at 9:30 A.M. To facilitate the speedy removal of refuse between 6 and 10 A.M. a number of flushers and flushing sweepers are required to stop their flushing operations at 6 A.M. to assist in loading the refuse wagons.

The contractors who remove the refuse are also required to dispose of it. Where city labor is employed the refuse is taken from the city by barging under a barging contract and by burning at a destructor at Shot Tower wharf, Waterloo Bridge, S.E. The residue on burning amounts to about 25 per cent of the original refuse. It is carried away by a further barging contract. The price for the removal of this residue is about 36 cents per ton of 2240 pounds. In 1905-6 there were 6613 tons of residue removed.

Final Dis-
position of
Refuse

The destructor is of the Horsefall, direct-tip type, of six cells, and has a capacity of between 60 and 70 tons of refuse per day. In addition to this refuse destructor, there are four dumping places where barges are loaded with refuse. The contract price for barging the refuse is about 52 cents per ton from any of the dumping places. The house refuse is removed from a large part of the city between 7 P.M. and 10 A.M.

The sewers are cleansed and detritus disposed of partly by the city of Westminster and partly by the London County Council. So far as the work done by the city is concerned, the cleansing is carried out under the supervision of a sewer inspector. This person has control, subject to supervision by the Assistant City Engineer and Assistant Superintendent of the Highways Department, of a staff of

Sewer
Cleaning

sewermen under four foremen. For the purpose of sewer cleansing, the city is divided into four parts. The work is carried out at night. The detritus is carted to dumps at the river where it is carried away under a barging contract. About 150 tons of detritus are disposed of per week. The sewers are cleansed by the cheapest and quickest methods available. Pipe sewers are flushed with water from hydrants and obstructions are removed by means of rods or with a hand line and chain worked from the manholes.

The brick sewers are more difficult to cleanse. If the detritus is not heavy and thick, boards the shape of the invert of the sewer are so fixed as to cause the water to back up behind them. The board is then released and the rush of water carries away with it the detritus in the sewer, the sewer at the same time being raked and swept by the sewermen. Sufficient water may not always be obtained by this method, in which event hose is used.

When the detritus is deep and heavy it is shoveled, into trucks, elevated to the surface and carried away. This method is used as little as possible. It is employed only when it is impossible to lubricate the detritus and carry it away by flushing and sweeping.

The catch basins are emptied at regular intervals, varying with the street conditions. In some streets they are cleansed once a week, while in others they are emptied only once in three months. If they are offensive they are flushed with a hose or powdered with disinfectants. There are catch basins every 120 feet or so, in places.

The same routine is observed in regard to reports in relation to sewer foremen, as described in the case of

the day traveling ganger and the cleansing foremen. The estimated cost, exclusive of water, for sewer cleansing for the year 1906-7 was \$12,247.20; catch basins, \$6682.50—total, \$18,929.70.

All depots under the supervision of the Highways Committee are maintained and kept in repair by men employed by the Committee, except in special circumstances, when estimates are obtained and submitted to the Highways Committee. There is an authorized staff of mechanics allotted to the Highways Committee consisting of blacksmiths, carpenters, painters, wheelwrights, and laborers. The plant includes 159 refuse wagons, 64 water vans, 36 sweeping machines, 251 orderly trucks, 40 flushing trucks, 4 motors, 5 trailers, a horse ambulance and a variety of other vehicles.

The four motors are largely used in connection with the removal of house refuse before 10 o'clock in the morning and, when necessary, with an interchange of bodies, to assist in street watering during the night. In this way they work seven days per week with one shift at rest and one shift cleaning. It is expected that the life of the motors will be at least ten years. The cost of repairs is estimated at about 10 per cent of the cost of the motor when the motor is used during the day and 20 per cent when used day and night. There is a contract for the repair and keeping in order of one of the motors at \$413.10 per annum for five years. The quantity of coal required has been found to be about 36 cwt. per week of twenty-four hours per day.

The advantages to be obtained from the use of motors depends upon the need of using them day and night.

MODERN METHODS OF STREET CLEANING

It is estimated that on this basis one motor will take the place of three sets of horses during the twenty-four hours, and if a motor wagon has a capacity of 6 cubic yards, which is about double the size of the ordinary refuse wagon, with a trailer of a capacity of 6 cubic yards, it appears that with day and night use one motor and trailer would take the place of twelve horses. Under these favorable circumstances, the motor would be cheaper than horse traction, but there are other advantages in employing motors. They are always ready for their work and do not produce dirt in the streets. They can pass in crowded streets with greater freedom and can be guided and turned in a more expeditious manner. The average cost of horse keep for the year ending December, 1906, for the 143 horses, was \$2.83 per horse per week.

The Assistant City Engineer and Superintendent of the Highways Committee are authorized to engage such temporary workmen as may be necessary from time to time, such employment being first sanctioned by the Highways Committee. The permanent staff is as follows:

Street Clean-
ing Force

- 44 refuse collectors
- 280 sweepers
- 40 orderly boys
- 18 flushers
- 148 carmen
- 9 motor drivers
- 5 horse keepers
- 37 stablemen
- watchmen
- storekeepers
- weighers

WESTMINSTER, LONDON

- 18 cleansing foremen
- 3 flushing foremen
- 1 destructor foreman
- 4 sewer-cleansing foremen
- 34 sewermen
- 55 men engaged in other duties

None but able-bodied men are engaged on the permanent staff, and at the time of their engagement they must be under forty years of age. Men are not retained in the service of the city after they have reached 65 years. Disabled and incompetent men are displaced.

The workmen are allowed legal holidays and a week's holiday in summer without deduction of pay. In case a laborer meets with accident on duty not attributable to his own serious and wilful misconduct, he is allowed a certain amount of pay for the accident, there being rules and regulations covering all cases. These rules apply also to cases of sickness or accident off duty.

For the performance of good and faithful conduct, stripes and extra pay are provided to the extent of about 24 cents per week over and above the regular rate of pay. The Assistant Engineer and Surveyor, and Superintendent of the Highways Committee are empowered to discontinue or suspend the grant of the stripe for sufficient cause. Overtime is allowed and rules regulating the allowance of pay for extra service. There is a code of regulations which govern the conduct of the men in all departments. Breaches of any of these regulations are punishable by suspension without pay or dismissal at the discretion of the Assistant City Engineer. In addition to the pay given

MODERN METHODS OF STREET CLEANING

the workmen, clothing is provided for them at the average cost of about \$19.44 per man per annum. The total expenditures of the Highways Committee was estimated to be equal to a tax of about 2 per cent in 1906. The total expenditures of the department, less an income of about \$29,160 from rent and various sources, amounted to about \$573,500. The wages alone for 1906-7 included in this budget were, for the regular staff, \$273,097.98, and for extra labor, \$9720—total \$282,817.98.

CHAPTER VIII

MANCHESTER

MANCHESTER is the center of a highly concentrated population. If an imaginary circle be drawn, with a radius of 20 miles, so as to take in the cities of Liverpool and Manchester, it will include a population of 3,225,000 inhabitants. There are here one city (Liverpool) of about 739,180, one (Manchester) of 637,126, one (Salford) 234,077, and fifteen more having a population of over 30,000 each, not to speak of thirty-five places having populations of from 5000 to 30,000 each. This averages over 10,000 to the square mile, or about 16 to the acre. It is misleading, of course, to think of this population as evenly distributed. It is, to a considerable extent, restricted to the municipalities mentioned.

The Manchester district is famous for its textile industries. There is no other manufacturing center comparable with it.

The cleaning of streets in the city of Manchester is carried on by a committee of the City Council consisting of the Lord Mayor, four Aldermen, and fifteen councillors, and is called the Cleansing Committee. They possess all the power and authority relative to the purposes for which they were created possessed by the Council itself. The total cost of the Department for the year ending March

**The Street-
cleaning
Authority**

31, 1906, was \$678,490.35, less an income from rural estates of \$1424.12, or a net cost to the city of \$677,-066.23.

According to an estimate made in 1906, the population of Manchester was 637,126, or about one-eighth of that of the city of New York. There were about 750 miles of paved streets and 121,169 dwelling-houses. The city covers 19,803 acres. Where traffic is heavy granite blocks are used and on streets of less travel blocks of grit from the Rosendale Valley, about 20 miles from Manchester, are employed. There are about 350 miles of streets paved with granite and about the same amount with grit. There is little wood paving. Tar-macadam has been experimented with, but the results are said not to have given satisfaction.

The sidewalks are laid with natural flags. There are 9,363,930 square yards of carriageway and 3,458,257 square yards of sidewalk.

The street-cleaning department has charge of cleaning both sidewalks and streets. The total amount of street sweeping done during the year 1906 amounted to 634,366,257 square yards. About 3,000,000 gallons of water were used upon the streets. The street sweepings comprised 80,369 long tons. There were collected 350,982 tons of refuse of all kinds.

The streets are cleansed with horse-propelled sweeping machines and are sprinkled. They are ballasted, or, as we say in America, sanded, with ground clinker from refuse destructors and with granite chips.

In addition to the work of cleaning the streets and

disposing of the ordinary refuse of the houses, the department is charged with the collection and disposal of nightsoil.

For the disposition of the refuse of different kinds two chief depots have been established. Each receives about one-half of the refuse of the city, one in addition, however, taking all the market garbage, fish, meat and offal from the slaughter-houses. The two depots deal together with the excreta from 65,000 pail closets and the contents of about 20,000 privies and middens and 80,000 refuse bins.

The ordinary house refuse is collected in the large clumsy, high, heavy one-horse tip carts common through England. As the carts enter the works, they pass, in turn, to a hopper on a level with the floor. Through this hopper the paper, ashes, and garbage of which the refuse is composed fall into a long, inclined screen. Here the combustible portion is separated from the fine ashes and dust and burned under boilers. These boilers supply all the steam required for power and other purposes about the works. The burnt refuse is cooled and ground and used with lime to form a mortar which sells for about \$1.00 per long ton at the works.

Collection
of House
Refuse

The excreta are collected in pails of galvanized iron, fitted with lids and closed hermetically by means of rubber washers. Upon reaching the works the pails are emptied into a double hopper and immediately cleaned out and disinfected with a mixture of carbolic acid and fine ashes which have been separated from the household refuse. The excreta which have been emptied into the hopper pass to the floor below where a revolving screen separates

Collection and
Utilization of
Excreta

the liquid from the solid portion. The solid part is sold as nightsoil.

The liquid portion, containing a small amount of finely divided solid matter, is run into storage-tanks fitted with mechanical agitators. Here sulphuric acid is added to fix the ammonia. The mixture is then run by gravity into a series of steam-jacketed dryers where it is reduced to a solid state. The gases from these dryers are conveyed underneath the grates of a cremator which renders them innocuous. The solid manure produced by the drying process is stored in large bins and eventually carried by an automatic conveyor to the top floor of the building where it is filled into bags and packed into railway cars standing on an adjoining siding.

While in storage preparatory to being bagged, the manure is fortified by the addition of a sufficient quantity of ground bones and dried fish refuse to bring it to a standard of value. When sold, the city guarantees that the manure always contains from $3\frac{1}{2}$ to 4 per cent of ammonia, 8 per cent bone phosphate, 0.75 per cent potash solids, and $38\frac{1}{2}$ per cent organic matter. The price received is about \$15 per ton.

Every care is taken to insure cleanliness in the depots and other places where refuse is handled and used. In the many years, practically a lifetime, during
Cleanness of
Depots which the works have been in operation, it is said that not a single case of infection has occurred.

Notwithstanding the peculiarly offensive nature of the work, the depots, stables, storehouses, docks, and other places visited by me were characterized by a degree of cleanliness and freshness not common even in industrial works about which no especially offensive

MANCHESTER

feature is associated. The quantity of refuse collected and dealt with at the two stations in Manchester amounted, in the year ending March 31, 1903, to about 270,000 tons, including about 80,000 tons of nightsoil and 70,000 tons of street refuse.

For dealing with this refuse there are 35 destructor furnaces, 15 boilers, 16 mortar mills, 18 drying Plant machines, and a correspondingly large number of other pieces of apparatus.

In addition, the city has works for repairing and making rolling stock, stores, disinfecting ovens, ambulance house, sawmill, brushmaking works, and stables, beside numerous subsidiary depots. The total value of the land and buildings belonging to the Cleansing Committee according to appraisals made by the City Surveyor on March 31, 1906, was \$2,733,093, and of rolling stock, apparatus, etc., \$305,271. The cost of the department for the year was \$677,066 without counting interest on the investments in property or depreciation of plant. Of this total, \$588,000 were spent for wages and salaries.

For the purpose of providing an outlet for the large amount of refuse dealt with, the city has purchased two country estates, one at Carrington, and the other at Chat Moss. Municipal
Country
Estates

The Carrington estate is about ten miles from Manchester, has been in the possession of the city about twenty-one years and is valued at about \$540,000. It consisted, when purchased, of 1100 acres, largely undrained bog land. At the time of purchase, it was so marshy that it was dangerous in places for a person to walk across it. Its value has been trebled under the city's management.

The method of reclamation adapted at Carrington for

MODERN METHODS OF STREET CLEANING

the purpose of utilizing the city refuse was as follows:

Method of Utilizing the Refuse The fields were set out in rectangular shape, each plot containing about 8 acres, the sides measuring 200 yards in length. They were then subdivided into about four portions, 200 yards long and 50 yards wide by drains about 4 feet deep at a cost of about 25 cents per rod or \$18.75 an acre. Each 2-acre lot was then drained across, 4 yards apart, at a cost of about \$1.12 per 100 yards or \$13.75 per acre. After the land had been drained it was spaded 8 inches deep at a cost of about \$9.68 per acre.

Heavy root and grain crops have been raised upon this land. About sixty acres are used for a nursery upon which shrubs are grown for the Manchester parks. It is said that the golden elder, rhododendron, privet, and poplar are grown there in perfection. For the rest, nurserymen and market gardeners occupy a considerable area and grow shrubs and vegetables on an extensive scale.

There are nearly twelve miles of light railway upon the estate and more than that length of good roads, all constructed by the street cleaning department. The roads and the ballasting on the railroads are made of rough refuse from the city.

The manure is sent chiefly by the Manchester Ship Canal from the wharves of the street cleaning department to Carrington, where by means of a steam crane it can be unloaded, at the rate of fifty tons per hour, and hoisted to the light railway which carries it to its final destination.

The estate does not pay full interest upon the money expended in the purchase and reclamation of the property, but every year the deficit is reduced

MANCHESTER

by reason of the increasing rental which is derived from it.

The quantity of manure which has been put upon the land is surprisingly large. It is stated that as much as 300 tons of nightsoil per statute acre has sometimes been used year after year upon the same field and for the cultivation of the same kind of crop. In fact, one piece of land has received an average of 1200 tons of nightsoil per acre for nine years without injury to potatoes grown in it, although cereal crops have been made too heavy. The quantity used is largely regulated by the character of the soil on which the manure is applied and the crop it is intended to grow. Few farmers use less than thirty tons per acre per annum and many farmers use double that quantity on the land owned by the city of Manchester.

Quantity of
Refuse used
upon the
Land

The peculiar kind of soil comprising the property is capable of receiving more of this kind of manure than can other soils. It is called peat moss. An idea of its character can be obtained from the following particulars concerning a representative section: The peat was 17 feet thick and shrunk upon drainage and cultivation to 9 feet. Beneath the peat was sandy clay or loam and below this boulder clay 26 feet 6 inches thick. At the base of this there was red sandstone.

The first crop planted was potatoes. The yield was excellent. No manure was required for a crop the following season.

Not only nightsoil is used upon the Carrington estate, but market garbage, which consists of cabbage leaves, potato tops, rotten oranges, onions, fruit of all descriptions, and vegetable refuse. The vegetable refuse is, however, first middened and allowed

Kinds of
Refuse
Handled

MODERN METHODS OF STREET CLEANING

to stand for at least six months, at the end of which time it is thoroughly decomposed and a large per cent of the moisture has been drained from it. It is then easy to apply to the land and is said to make an excellent manure.

The total quantity of refuse of various kinds sent to the Carrington estate from 1889 to 1906 was 730,774 long tons. The quantity sent to Chat Moss in the eight years ending 1906 was 443,058 tons.

The following kinds of refuse were received in the amounts stated at each place in 1906:

	Carrington	Chat Moss
Nightsoil	13,672 tons	29,420 tons
Clinkers	628 "	8,950 "
Street sweepings	546 "	15,811 "
Stable manure	117 "	290 "
Garbage		1,505 "
Old paving-stones		202 "
	14,963 "	56,178 "
Total		

Raw peat has been taken from the Carrington estate, dried, and used as bedding for horses. It makes an excellent manure after having been used in the stable, comparing favorably in point of analyses with straw manure, and fresh street sweepings.

The quantity of refuse sent to Carrington being largely in excess of the requirements of the estate, the authorities in 1900 purchased a second estate, Chat Moss, containing 2600 acres. Chat Moss is about seven miles from Manchester and is also located upon the Ship Canal.

CHAPTER IX

PARIS

PARIS is universally conceded to be one of the cleanest and most beautiful of cities. Many of its streets have been built in accordance with wise and comprehensive plans, a fact which has contributed substantially to its successful development.

Under Haussman, who was appointed Prefect of the Seine in 1853 and held office until 1870, a magnificent scheme of street improvements was laid out and systematic plans were made for remodeling and rebuilding large areas of the city.

The Recon-
struction of
the Streets

The work done in carrying out this plan is estimated to have cost upward of \$250,000,000 up to 1870. The annual cost of work along these lines has averaged for the last twenty-eight years over \$4,000,000. This is a slightly larger sum than has been spent each year by London for street widenings and improvements.

Many of the boulevards which run through the heart of the city are 114 feet 6 inches in width and others are wider. The Avenue de l'Opera, one of the largest streets, is 98 feet 6 inches wide and has a roadway of 52 feet 6 inches. The Avenue des Champs Elysées has a total width of 233 feet and a roadway of 88 feet 6 inches. This may be compared with Fifth Avenue in New York, 100 feet wide with a roadway of 40 feet, and Broadway, 80 feet wide with a roadway of 44 feet. Trees, gravel footways, and benches are features of

MODERN METHODS OF STREET CLEANING

Parisian streets. The population of Paris in 1901 was 2,714,068.

The street-cleaning authorities of Paris are charged with the construction and maintenance of streets and sidewalks as well as with sweeping the streets and sidewalks, sprinkling the roadways, removing house refuse and removing dirt, ice, and snow from the streets.

Scope of
Street Clean-
ing Work

The work is done by a branch of the Department of Public Works. The technical skill required is drawn from the national government's *Corps des Ponts et Chaussées* and from a corps of engineers belonging to the city service. Many of the streets are parts of national highways. In consequence of this, the total cost of maintaining and cleaning the streets is largely borne by the government.

The street-cleaning operations are performed by the city with certain exceptions: The drivers of carts, of sweeping-machines and of sprinkling-wagons with the horses employed in these operations, are furnished by contractors, but the apparatus belongs to the city. The horses, carts, and drivers of the refuse carts are furnished by contractors. The material collected belongs to the contractors.

The personnel of the force engaged in sweeping and cleaning the streets was composed on January 1, 1907, as follows:

Personnel

Division superintendents	51
Section foremen	174
Section men	1782
Workmen	1477
Total	3484



Cleaning the Market Place at Paris.



Paris—Receptacles for Kitchen Refuse set out to be emptied in the morning.

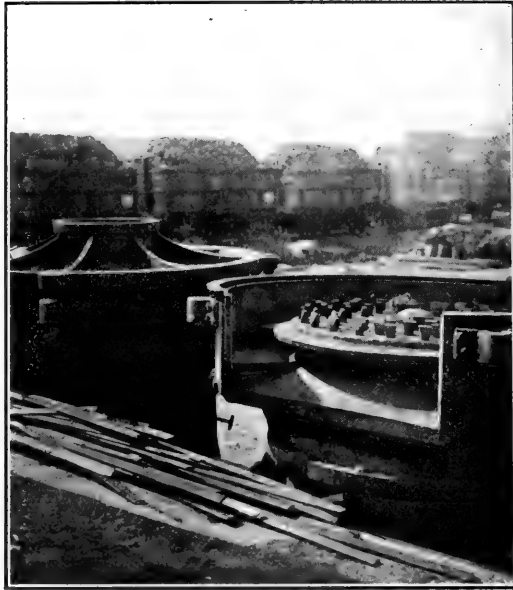

Paris—Machinery for Grinding Refuse and Railway Cars for transporting it to rural districts to be used as fertilizer for sugar-beets.



Clichy, near Paris—Settling-basin for the Sewage of Paris. Sand and other heavy, coarse matters settle and are screened here. The basin is constantly dredged. The material excavated is deposited in barges and carried to the country and spread upon land.

PARIS

In addition to these, refuse men to the number of 529, were stationed in the carts used to collect the house refuse. These men empty refuse from the boxes in which it is placed by the householder and at the same time help sort it for the benefit of the contractor. These men receive from the city about 28 cents per day.

There were also upward of 630 drivers of carts and 350 drivers of sprinkling-wagons and sweeping-machines.

In addition to the force already indicated, there were men engaged in cleaning the paved streets, who had been supplied from the city force which is charged with maintaining the streets, to the number of 595 workmen and 37 foremen. The total number of men here accounted for is 5625. The total salaries amounted to about \$1,562,000.

The streets are generally swept by machines and the sidewalks are cleaned by hand-brooms. This work is done in the morning between 4 and 7 A.M., when the vehicular travel is light. The streets are first watered by sprinkling-carts and then promptly swept by horse-brooms. Men with brooms or shovels or, if the weather is wet, squeegees pile the material.

From 6:30 to 8:30 A.M. in summer and 7 to 9 A.M. in winter the house refuse is collected. This is done by contract, but with the aid of one ragpicker, and usually two helpers in the employ of the city. Ragpickers, generally women, overhaul the refuse on the sidewalk during the operations of the street-cleaning department before the collecting carts arrive.

After the carts have passed, the gutters are cleaned of the wastes collected by the street-cleansing opera-

tions. Street dirt which can be shoveled is hauled away in carts; the rest is flushed into the sewers.

So much water is used on the streets and to flush the gutters that algæ grow and make some of the gutters permanently green. The city has separate water-supplies for drinking and cleaning purposes. But little grit reaches the sewers, considering the use to which they are put and the fact that there are no catch basins. Comparatively little sand is used on the streets and it is said that some of the sand which gets into the sewers is taken out, washed, and used over again. Immediately after showers squeegees are used and some sand is sprinkled by hand on the hills.

From 11 A.M. to 1 P.M., the street-cleansing force lays off for luncheon, after which the men resume work until 4 P.M. This final period is usually occupied in flushing and sweeping the gutters, most of which have been cleaned in the morning, and in collecting the papers and other refuse thrown into the streets since the morning cleansing. The larger refuse is placed in some quiet place off the main thoroughfares where it is likely to cause little annoyance until it can be collected by the wagons of the regular morning service, or, if necessary, by a special service in the evening.

Since gutter flushing is one of the most prominent features of Paris street cleaning, a few more words may be said regarding it. The water is obtained from hydrants concealed beneath the sidewalk and opening by simple overflows through the outer facing of the curbs. When the water is turned on it usually flows close to the curb along the street according to the grade; but if the grade is insufficient for this purpose, the direction of flow is regulated by tem-

Gutter
Flushing



Paris—Street Sprinkling by Hose.

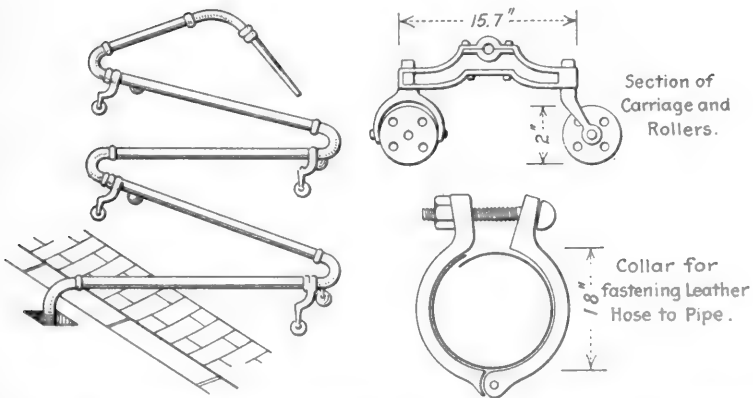

Iron Pipe Sprinkling Apparatus used in Paris. The lengths of pipe are about 6 ft., joined by rubber or leather hose, and supported by hollow spherical rollers. At one end is a fitting by which it is attached to a hydrant beneath the sidewalk; at the other is a nozzle.

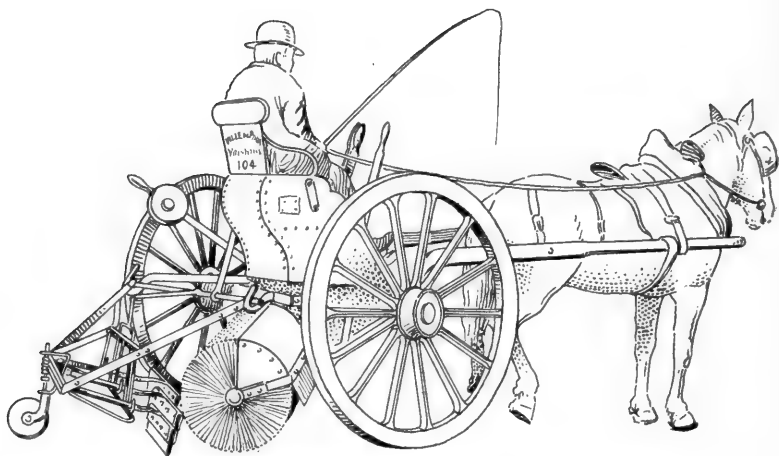

Standard Horse-propelled Broom and Rubber Squeegee used in Paris. The broom is about 5.4 ft. long. This machine is said to clean 43,000 sq. yds. of pavement in ten hours.

porarily damming the gutter by means of coarse cloths.

The progress of the stream is, under the best circumstances slow—often less than 100 feet per minute. As the water advances, it spreads out over the dry surface picking up and carrying at the forefront of the stream a surprisingly large amount of dust and solid matter, such as animal excrement, cigar ends, fruit refuse, and paper. The stream is very broad and dirty at the head but further back becomes narrower and cleaner until eventually it looks as clear as a mountain brook.

The cleansing effect of the water is much increased by the operations of an attendant who, armed with a long-handled, stiff broom, sweeps into the gutter such dirt as is visible from the sidewalk and from the street for a distance of 8 or 10 feet from the curb. This sweeping is done with long, easy strokes. The broom is continually dipped into the flowing water which both cleans the broom and prevents the raising of dust. The clean water is often purposely swept out upon the broad carriageway so that when the gutter flushing is finished the street has been rather well cleaned for a space of 10 feet or so, to say nothing of the sidewalks.

Anyone who has watched the operations of gutter flushing in Paris on a hot summer day is likely to be impressed with the idea that, under the conditions which exist in Paris, it is an excellent procedure. It transports immense quantities of filth to the sewers at times and under circumstances which are under thorough control. The kind of dirt which is thus carried off is at once the most difficult for a street-cleaning authority to deal with and the most dangerous to health. The

practice makes little trouble in the sewers, for they were built with the idea that they would be used in this way and the cost of cleansing them is not considered a serious objection when the benefits of the system of gutter flushing are considered. To remove 25,000 cubic meters of sand from the sewers costs 66,000 francs, which is about 33 cents per cubic yard.

The sewers of Paris are among the most interesting sanitary features of the city. The first modern sewer in Paris was built in 1851. The system is now one of the most complete to be found anywhere. The main sewers often exceed 15 feet in diameter and are used for many purposes beside the conveyance of sewage. Suspended in the sewers are water-pipes, telegraph and telephone wires and pneumatic pipes for the conveyance of letters.

The sewage flows through the sewers to a point near the western part of the city where part of it is screened and pumped to farms and part allowed to flow into the Seine. The sewage farms cover an aggregate area of over 2000 acres and are among the oldest in existence. The sewerage system was laid out by Belgrand in 1856.

All workmen receive their wages during sickness and while on military duty. They get a vacation of twelve days each year with full pay. There is an old-age pension to which the men give 4 per cent of their salary and to which the city also contributes. The working day is ten hours except for those who begin at 4 A.M. These men work seven hours only. The men are not uniformed. The workmen carry on their operations in a deliberate not to say dilatory manner.

Vacations
and Sick
Pay

The principal cleaning which the streets receive is done by horse-propelled brooms. After many experiments with different forms of apparatus the brooms which have been found to give the best service are of the rotary form having two wheels. These brooms move along the axis of the street and throw the sweepings to one side. The brooms are generally worked in gangs of 2-3 and are accompanied by men on foot who sweep and shovel the refuse thrown by the brooms into pits for final removal by carts. The brooms have bristles of split bamboo and are 7 feet 2 inches wide. They are capable of sweeping 7175 square yards per hour with the horse walking about 2.5 miles per hour. This amount of sweeping is considered equal to the work of about ten men. The city owns 440 of these machines, of which about 270 are kept in service and the remainder in reserve. About 77 machines are especially adjusted for sweeping macadam pavements.

The Work
of Horse
Brooms

Horse-propelled squeegees are employed on asphalt and wood pavements. They are of simple design and somewhat resemble common road scrapers. The scraping edges are strips of rubber about .3 inch thick and 3 inches wide. They are held in position by sheet-iron guides. The scraping edge is set like a machine broom in an oblique direction and scrapes the refuse to one side. These squeegees are useful in rainy weather and when the dirt on the streets can be softened by sprinkling-carts so that it is ready to be moved like mud. Softening by sprinkling followed by squeegeeing or sweeping with rotary brooms is the chief reliance of the city in getting rid of fine dirt which cannot be shoveled away.

MODERN METHODS OF STREET CLEANING

Finally, it remains to describe a new piece of apparatus which both sweeps and scrapes the streets. This machine is especially intended to clean smooth pavements like asphalt and wood. It is composed of an ordinary cylindrical sweeper behind which is a frame provided at its extreme rear with a bearing wheel and with a rubber scraper between this wheel and the brush. The scraping edge is in three parts. It is intended to remove such dirt as may be left by the broom and leave the street in the same condition as when cleaned by hand labor. The machinery controlling the scraper is independent of that controlling the broom, a feature which permits of the same apparatus being used to cleanse different kinds of pavements. It should be noted that the refuse dealt with by this machine is, for the most part, of the consistency of soft mud.

Experiments have been made with automobile sweepers and sprinklers. The machines were of 15 H.P. and driven by gasoline. One gallon of gasoline was capable of driving the machine about four miles. The broom was about 7 feet long and was placed under the frame of the machine and between the forward and rear wheels. It was capable of sweeping 120,000 square yards per day as compared with 42,000 square yards swept by a horse-drawn machine broom. It cost about \$8.11 per day to operate the machine as a broom and \$6.13 as a sprinkler, including operating and interest charges. To use the machine as a sprinkler and sweeper cost \$7.12 per day as against \$7.76 for sprinkling and sweeping by horse-propelled machines.

The sprinkling of streets is accomplished by means



Paris—A Group of Rag-pickers at an Incinerating Plant.



Paris—Articles recovered by Rag-pickers from House Refuse overhauled on the Sidewalk.

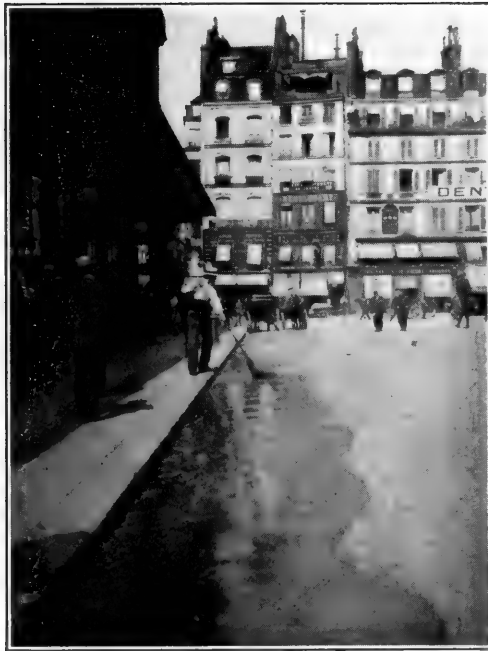

Paris—Gutter Flushing. Sweeper assisting the water in removal of street refuse.

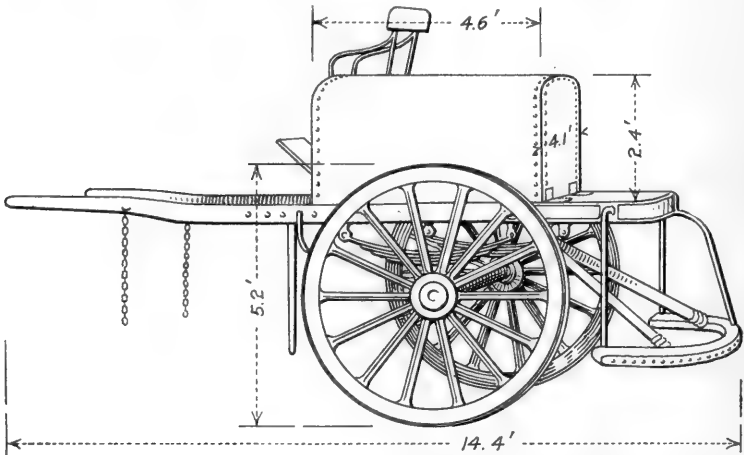

Ordinary Street-sprinkling Cart used in Paris. The tank has a capacity of about 317 gallons. The path sprinkled varies from 11.5 to 18 ft. wide.

of hand-carts, by carts propelled by horses, and by hose.

The hand-sprinkling cart has a capacity of 40 50 gallons and may be handled by one man. It is generally used on certain walks and other places where the use of large sprinklers would be impracticable and where only a very small quantity of water is required.

Sprinkling
Carts

The horse-propelled cart has a capacity of from 250-350 gallons and can sprinkle a surface of 5400 square yards per hour.

The city has 144 hand-sprinklers and 458 sprinkling-carts propelled by horses. Of this total number of 602 carts, about 138 are always kept in reserve. A cart can sprinkle about 5400 square yards per hour. They can be adjusted to deliver $\frac{1}{4}$ to $\frac{1}{2}$ gallon of water per square yard of pavement. There is also in service for sprinkling the large streets having a slow-moving traffic, a steam automobile sprinkler. This machine is somewhat in the nature of an experiment.

Sprinkling with hose is accomplished by means of hose about 2 inches in diameter, from 35 to 50 feet in length, and in five or six pieces mounted on suitable carriages. In 1905 there were 1512 of these hose outfits. They could be attached to 7366 hydrants of which, however, only about 1800 were in actual use. The hose is used where a large amount of water is needed for sprinkling, as, for example, where the dirt is thick and heavy. It is employed largely on asphalt, wood, and macadam. Each hose uses about 20-25 gallons per minute and has a radius of action of about 65-80 feet. A man can sprinkle about 2500-3500 square yards per hour.

Hose
Sprinkling

One of the advantages claimed for hose sprinkling is the ease and completeness with which it can be employed to reach and suit the peculiar needs of every part of the street which requires attention. This is in contrast to the work of sprinkling-carts which give the same amount of water to every square foot of pavement irrespective of the needs of any part. At the same time the use of hose requires intelligent attention on the part of the workmen, or pavements, especially macadam, may be injured and traffic seriously impeded.

The area of streets sprinkled was, on January 1, 1907, 12,858,000 square yards. Of this about 3,258,000 were sprinkled by hose and 9,500,000 square yards by sprinkling-carts.

House refuse is placed in boxes which the householders are required to provide for themselves. The size and shape of these boxes vary greatly. They are placed on the sidewalk outside of the house line in time for the early morning collection. The contents of the boxes are sorted on the sidewalks by rag-pickers just before the arrival of the collecting carts.

These rag-pickers are an institution in Paris. They are probably the best organized and most efficient body of unofficial scavengers in the world. They number about 20,000-25,000 and appear to have so much influence, that objectionable as is their calling from a sanitary standpoint, no satisfactory way of abolishing them has yet been discovered.

To see the chiffoniers to advantage it is necessary to visit the boulevards in the early morning just before the great refuse carts with their noisy crews appear. The refuse collections of the dwellings, cafés, and shops have been put out for removal



Paris—An Incinerator. Mixed house refuse is brought in large carts and dumped under the shed at the left. It is there picked over and useful articles recovered. The residue is ground up and shipped by rail to the country or burned in an incinerator. The incinerators were new in 1907.



Brussels—Refuse Cart in front of Incinerator.



Brussels—Refuse Incinerator. Entrance for teams. Showing the cells where the refuse is burned.



Brussels—Headquarters of Street Cleaning Department. Stack of new incinerator in background. This incinerator resembles the one at Hamburg.

and the finer dust and dirt of the houses are being swept out upon the sidewalk.

Every conceivable form of receptacle is used by the householders for the litter and garbage which they wish the city to take away. The various kinds of waste are not kept separate but are thrown into one box or barrel or tub. A favorite receptacle is a rectangular zinc can about 2 feet long, 2 feet wide, and 18 inches deep.

A few minutes before the collecting carts arrive, the rag-pickers, clad in nondescript garb and powdered with dust appear and with much speed and system spread a square of burlap or other cloth upon the sidewalk and tip the refuse can over upon it. The contents are quickly overhauled, the gleanings being thrown into large sacks. The refuse which is of no use to the picker is then dumped back into its original receptacle, the burlap is taken up and the worker proceeds to the next house. When the sacks are full they are taken to some neighboring side street which serves as a kind of central depot from which they are later hauled away by carts drawn by good-looking horses.

The picking is expeditious and thorough. The pickers are of both sexes, often young, and, were it not for their dirty apparel, would sometimes be prepossessing.

Considering the well-known economy practiced by the French people, it would not seem that a living could be gathered from overhauling in this hurried fashion what other people have thrown away and the fact that the calling is profitable to so many persons strongly suggests that it is possible to accomplish good results in countries where the value of household

MODERN METHODS OF STREET CLEANING

wastes is greater and where the work of picking can be carried on under more advantageous circumstances.

The carts for collecting the refuse are very large, high, open, and built after the common French custom with two wheels and provision for horses harnessed tandem. Two or three men accompany each cart, one remaining inside and the others throwing the receptacles in to him to overturn and empty. Even here there is some picking done, desirable matters being placed in separate bags or baskets hanging to the outside of the cart. The men are rough and noisy and use the receptacles with little care. The refuse is hauled to boats and to depots on the outskirts of the city to be burned or taken to the country to be used as fertilizer.

The collections are made by contractors aided by city workmen. The contractors are charged with removing the refuse to depots in the northeast, northwest, southeast, and southwest of Paris. The material is the property of the companies which collect it. After the glass, iron, and other mineral matters are picked out of the refuse at the depots, the residue is ground up for fertilizer or burned.

The sidewalks and streets of Paris in time of snow are cleared and the gutters kept free by the city. At times of snowfall the administration enlarges its force by the employment of temporary laborers, an arrangement which has to be made each year.

Since 1880 salt has been used to facilitate the disposal of the snow. The salt used is an anhydrous

variety of sodium chloride, and is exempt from the heavy duty imposed by the Government on salt for most purposes. It is obtained from the east of France.

The salt is scattered on the streets when the snow commences. As the snow falls it melts rapidly on this saline bed. If the snowfall is heavy, it may become necessary to add another dressing to the bed of salt. For a fall of two inches of snow about $4\frac{1}{2}$ ounces of salt per square yard are required.

When the action of the salt upon the snow has been completed and the mass has been converted into a semi-liquid condition, it is swept toward the gutters by means of sweeping machines and scrapers. The machines may also be used without the use of salt, but this generally reduces their effect.

The sweeping begins at the center of the roadway where a path 10–12 feet wide is kept open. In case the streets are icy or slippery they are sanded or cindered. The sidewalks are cleared by hand and with brooms as far as practicable. As much use as possible—apparently a very large use—is made of the sewers in disposing of the snow. Men are employed in the sewers to see that the snow passes through without obstruction. In case of an exceptionally heavy storm, carts are used to carry away the snow.

The total street surface cleaned by the city, according to calculations made for January 1, 1907, was 19,656,000 square yards, including 8,581,000 square yards of sidewalks and alleys. An analysis of this area, according to the kind of pavement, follows:

Pavements

MODERN METHODS OF STREET CLEANING

Stone	6,764,000 sq. yds.
Macadam	1,415,000 “
Asphalt	500,000 “
Wood	2,396,000 “
Sidewalks and alleys	8,581,000 “
Total	<u>19,656,000</u> “

Cost of Cleaning For the year 1906, the cost of cleansing, including the cost of removing house refuse was

Wages	\$338,051
Material	<u>245,087</u>
Total	\$583,138

This total applied to a road surface approximating 11,000,000 square yards of street pavements gives 53 cents as the cost per square yard of street pavement cleaned per year.

The cost of removing refuse amounted in 1906 to about \$175,600. The number of cubic yards of refuse removed amounted to 1,721,000. The price per cubic yard was, therefore, about 10 cents.

CHAPTER X

BERLIN

BERLIN, with an area of about twenty-five square miles and a population, in 1906, of 2,040,148 inhabitants, is the third largest city in Europe. It is the greatest manufacturing center on the continent. It is the capital of Prussia and the headquarters of the imperial government. There is no more enterprising or progressive city anywhere. In respect to its methods of municipal administration, Berlin is regarded by many as a model city.

The sanitary regeneration of Berlin dates from the purchase of extensive territory in the environs, in 1861, but it was not until the advent of the era of prosperity which followed the wars of 1864-71 and the establishment of Berlin as the national capital that the admirable public works and institutions which now exist were begun.

Up to this period the city had not been notable for sanitary enterprise. The sewage was discharged into the little Spree, the water-supply was in the hands of a private corporation, and the general government controlled the streets.

Following the transfer of street control to the municipal authorities in 1873, there began a period of wholesome development which has produced remarkable results. Streets were widened and straightened. The municipal gas works which had been acquired by the

city in 1870 were greatly extended. Parks were laid out, tenement-house reforms were instituted, encouragement was given to transit improvements, and public hospitals, city slaughter-houses and markets were built; the water-supply was taken under municipal management and was greatly extended and improved. A sewerage system was built and a sewage disposal project was initiated which has no parallel for extent and elaborateness of detail.

A remarkable feature of municipal development in Berlin has been the degree to which public works have been made self-sustaining. It is said that the water works and gas works more than pay for themselves and that the sewage disposal works bring in a considerable income toward the payment of their operating expenses. Every department seems to be run nearly as well as though it was a private enterprise. This is in accordance with the German idea of municipal administration.

The status of civil engineers and other professional persons employed on municipal public works is quite different in Germany from the status of persons in similar places of responsibility in America. In Germany the mayor is an expert in municipal administration and is often appointed for life, with or without a preliminary trial. In those cities where the term of office is limited the mayor is generally appointed for a dozen years or more. It is not uncommon for a mayor to be called from another city where he has made a conspicuous success, to come and take charge of the management of a larger place. The mayor is chosen by the council, an elective body, and not by the people at large.



Berlin—Hand-sweeper at work in front of Palace of the Kaiser.



Antwerp—Snow Plough. Low boxes for household refuse fitted together on wheels, in the background.



Electrically-driven Machine used in Berlin for Cleaning Streets—the highest development which street-cleaning machines have thus far attained.

BERLIN

The council in German cities is a very important body. Not only does it select the mayor, but it chooses his technical associates. The council takes the initiative in inaugurating public improvements, provides the way to execute them, and is, in fact, the material, visible embodiment of municipal authority.

In Berlin there are 126 members of the council; the members are elected one-third at a time for six-year terms. The position of councillor is honorary and is held in high esteem by professional and business men of the best intellectual capacity. The council is divided into standing committees for the execution of various duties.

The executive head of a city department in Germany is termed a magistrate and the collective body of magistrates, *magistratsrath* or *stadtrath*. From the burgo-master, or mayor, down, all are the most capable experts obtainable, whether in law, finance, education, charity, street cleaning, water-supply or sewerage work. In Berlin there are 34 members of this body, 17 of whom receive salaries. The remainder contribute their services free of charge. The salaried officers are civil service appointees. The technical chiefs are appointed for life or for long terms with the practical certainty of reappointment if their conduct makes this possible. The unpaid magistrates are men of means who are not professional experts, but are willing to devote time and skill in municipal affairs to the service of the city. Their work is chiefly deliberative and advisory.

The salaries paid to the technical heads of departments appear to American eyes small, but it must be remembered that in Germany official positions are highly prized for the honor which they are supposed to

bring. The salary of the mayor of Berlin is about \$7500 and that of the paid magistrates about \$6200. Coöperation exists to a remarkably efficient degree between the magistrates and councillors.

Berlin has been made a sanitary city in spite of, and not because of, natural conditions. The situation was peculiarly unfavorable for drainage. Berlin lies in a low sandy plain traversed by sluggish streams. A great deal of pumping is required to supply the city with water and to carry off the sewage. The drinking-water is pumped and filtered and delivered under pressure from a considerable distance in the suburbs. The sewage is collected from different parts of the city into a dozen central districts. It is then pumped long distances into the country where it is used to irrigate farm lands owned by the municipality. The lands acquired for the disposal of the sewage cover an area greater than the area of Berlin itself. Because of this property Berlin is one of the most extensive owners of rural real estate in Germany. The work of extending the sewerage and sewage disposal works is still continuing and will last as long as the city continues to grow.

In such works as the construction of streets, sewerage and water-supply systems, the German plan is to keep steadily ahead of the demands so that the city may never outgrow its sanitary requirements. This is in direct contrast to American practice and is the more remarkable in the case of Berlin, for, since its remarkable transformation beginning forty years ago, the city has more than doubled in population.

The streets of Berlin are long, straight, wide, well designed, and generally well paved. The most famous



Charlottenburg, near Berlin—House Refuse Cart with Can of Refuse being emptied by mechanical appliance which prevents the escape of dust and odor.



Charlottenburg, near Berlin—Watering-cart and Rubber Squeegee for Cleansing and Drying the Streets. This is a new type of apparatus which is much employed in continental cities.



Berlin—Covered Wooden Cart ready to unload refuse upon railway cars for transportation to country for final disposition.



Berlin—Covered Wooden Cart used to collect House Refuse. This cart is intended to be dustless and odorless.

BERLIN

street is the Unter den Linden, the scene of the capital's most fashionable shops, hotels, and restaurants. It is 196 feet wide and about two-thirds of a mile long, at one end opening into a park and at the other into a great public square with palaces, museums, and theaters. The Linden with its rows of trees, bridle path, carriageway, and two side roads might really be called a parkway, although centrally located and an important thoroughfare for vehicles. Cafés are numerous and are patronized by thousands of people, who eat and drink at small tables either on the sidewalk or just within doors, at great windows which are removed in fine weather to allow an unobstructed view of the passing throng.

Character of
Streets

Berlin makes an energetic effort to keep its streets clean. The organization is military in type and, as is common in Germany, many of the details of the work are minutely planned and reduced to the form of specific printed directions.

Military
Character of
Organization
of Street
Cleaning
Force

The authority in charge of street cleaning is a joint committee of twelve made up from paid and unpaid members of the city Council. Under this committee, in the capacity of executive officer, is a chief who has direct charge of the operations of the department. Extraordinary operations, such as large, temporary increases in the force or the purchase of supplies in large quantities, must be approved by the committee, but the technical chief has much latitude.

For purposes of administration the city is divided into thirty-three street-cleaning districts, over each of which is an inspector who is responsible for the work done in his territory. The districts are grouped into four divisions presided over by a head inspector. The head

MODERN METHODS OF STREET CLEANING

inspector is responsible for the work of the divisions under his charge and is required to aid and direct his subordinate inspectors in the details of their operations. He has authority to exercise disciplinary powers for small offenses.

All the men from foremen down wear uniforms and have been soldiers. The uniform consists of a long, black, shabby-looking blouse, white trousers, black boots, and a cap—the latter of the unvarying type of Prussia. The uniforms are supplied to the men gratis. The chief and his head inspectors are provided with motor cars of small but convenient design.

The working force consists of 133 foremen, 1414 workmen, and 509 boys, making a total of 2056 employees. In addition there are about 100 men and women employed about the yards and at the 82 public comfort stations. The wages paid appears ridiculously small as compared with the wages paid in America for similar work, and the difference appears greater when the greater energy of the German workman is taken into account. The foremen receive \$1.07–\$1.13, according to the length of time they have spent in the service. Common laborers get \$.83 to \$1.01, and the boys \$.54 per day of eight hours. The total expenditure for labor was \$622,000 in 1906.

Workmen who are taken sick are allowed full wages for six weeks or longer in case of accident or sickness incurred in the performance of their duty. Pensions are provided for workmen grown old in the service and for the widows and orphans of members or former members of the force. In 1906 there were 126.8 cases of sickness aggregating 19,454 days of absence among the men.

**Rewards and
Sick Allow-
ances**



Charlottenburg, near Berlin—Receptacles for the Separate Collection of Kitchen Waste, Ashes, and Paper after, a plan which is a great improvement over that followed in New York.



Charlottenburg, near Berlin—A Street Cleaning Official. To the right is a pile of street sweepings about one year old ready to be used upon flower beds in the city parks.



Exterior.

Charlottenburg, near Berlin—Dustless Dump for Refuse Wagons. Curtains are drawn behind the horses to prevent the escape of dust.



Interior.

BERLIN

Rewards are offered for long and faithful service, and it is interesting to observe that in 1906 there were twelve men who received allowances of money for this reason. Each of these had served the city well for twenty-five years and the reward which was divided among them was \$232.

The total length of streets cleaned by the city in 1906 was 316 miles. The area cleaned daily was 8,160,000 square yards. The area allotted to each laborer was about 6000 square yards of street, including roadway and sidewalk, or 3750 square yards of street. The allowance of street area cleaned daily per man was 3960 square yards. The boys are given an average of 6260 square yards of asphalt to keep in order.

Length and
Area of
Streets

The city does not clean all the streets free of cost. A charge is made for cleaning the tracks of the street cars, private streets, and new streets. These returns bring in about \$50,000 per year. The sale of waste matters, old apparatus, and entrance fees to public comfort stations increase the revenue by nearly an equal amount.

The work of cleaning the streets proceeds from the 33 depots. Attached to these are yards for the storage of apparatus, etc. The streets are swept at night by revolving machine brooms propelled by horses. There were 95 of these brooms in regular service in 1906. The bristles are made of Pissava and last, on an average, 21 days. The machines themselves last 18 to 24 years. The machines work at night, beginning at 11:30 P.M. and continuing for six to seven hours until the assigned work is done. The horses and men to drive them are furnished by

Use of
Sweeping
Machines

contract; the city does not own any horses for its street-cleaning department. The teaming costs \$1.54 to \$1.67 per machine per night, according to the division in which the work is done. This sum includes the horses, men, and maintenance of machines, except the supply of revolving brooms.

Sixteen horse-propelled rubber squeegees were in use in 1906. The cost of teaming, sheltering, tending, and maintaining these scrapers was \$6700.

The street sweepings resulting from the work of the brooms are removed by contract for about \$251,000 per year. The quantity of material removed in 1906 was 175,610 loads or 481 loads per day. The quantity varies greatly, as, for example when rainy weather follows a dry period.

The removal of snow is done by the contractor who removes the street sweepings. The price paid in 1906 was 27 cents per cubic yard. The contractor is obliged to procure the necessary carts for a ^{snow} rapid removal of the snow which is piled in heaps for him, and to provide the dumping places. The number of cart loads is determined by check marks and is considered satisfactory. It is interesting to note that the city did not pay for the street sweepings contained in this snow. The average monthly quantity of street sweepings was deducted from the total loads of snow and sweepings removed and the contractor was paid the difference.

The removal of snow is sometimes a serious matter in Berlin, snow storms sometimes taking place which have many of the features of the worst so-called blizzards in New York. During the winter of 1906-7 there were 410,582 wagon loads of snow removed at

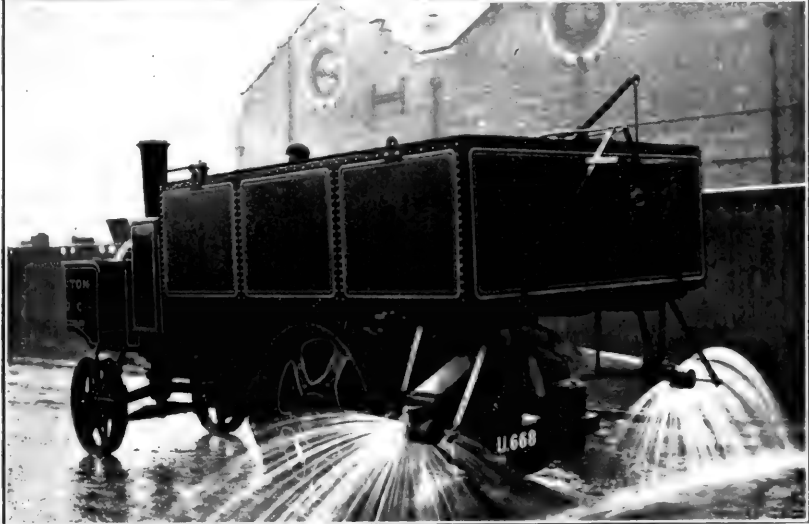

Courtesy of "The Engineering Magazine."

Above, "N. A. C." Two-ton Sprinkling Wagon used in Berlin. Below, Mann's (English) Steam-driven Street-sprinkling Wagon. The German wagon has a width of water distribution of 65 feet, uniform pressure being maintained by compressed air; capacity, 1320 gallons; vertical four-cylinder engine of 18 horse-power.

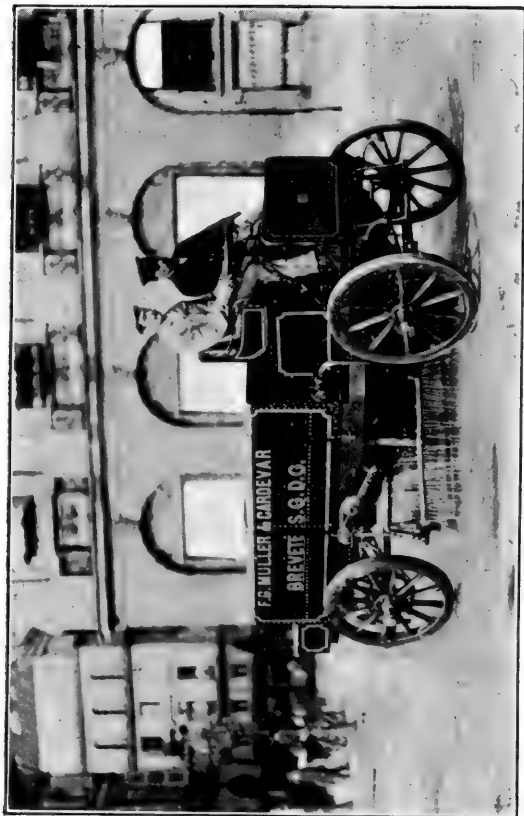

Courtesy of "The Engineering Magazine."

European Combination Street Watering and Sweeping Machine. Capacity of tank, 555 gallons; width of water distribution, 25 feet; 12 horse-power combustion motor under driver's seat.

a cost of about \$293,000 for carting and \$62,500 for extra labor.

The streets are sprinkled before they are swept at night in order to lay the dust in the daytime and at certain seasons of year to help remove the slimy mud which the French call *butter*.

Sprinkling

This greasy mud is everywhere a matter of serious concern in Europe.

The city owns the sprinkling-carts and lets a contract after public bidding for the necessary horses and men to operate them. Horse contractors in 1907 received \$2.00 per cart per day.

The Hiring of Horses

The contractor's men must be well and uniformly clothed and must obey the instructions of the city employees on pain of immediate dismissal. Once a year the carts must be painted at the expense of the contractor and they must be kept and sheltered by him at all seasons. In 1906 the number of carts in regular use was 301 and their operation cost \$128,000. There were, in addition, 67 sprinkling-carts in use most of the year to aid in cleaning the streets. This cleaning was usually done at night, but in places where the traffic was very heavy, it was sometimes performed by day. The idea is to flush the finer street dirt into the sewers.

In washing a street during the day a water-cart first passed down the middle of the street sprinkling a large amount of water. This was followed at once by revolving rubber squeegees operated by horses; these scraped the mud to one side.

Day Washing of Asphalt Streets

The cart passed again and again, each time promptly followed by the squeegees until six to eight trips had been made and the whole breadth of the street covered.

While this was proceeding men and boys with hand-brooms and squeegees helped clean out the car tracks and inequalities in the pavement.

When the work was done the street was clean except for the gutters for a distance of two to three feet from the curb. Here was dirt which had not flowed into the sewers. The inlets to the sewers are of the usual horizontal type. This street washing did not seem a wholly desirable proceeding to carry forward during the daytime on a crowded street. It placed a good deal of dirty water on the streets at a time when the public were not prepared for it. There was much splashing and spattering of mud upon garments, sidewalks, and even shop windows.

Several types of carts and machines are used to clean the streets, the idea seeming to be to experiment to some extent in the hope of finding the best kind for the work. It is thought that one of the best watering-carts procurable is a four-wheeled cart which sits very high and sprinkles from between the fore and hind wheels. Much or little water can be used according to levers placed on the driver's foot-board. Sprinkling can be done on one or both sides according to choice. It takes about as long to fill one of these approved watering-carts as to empty it. The hydrant is much too small.

One of the best squeegees is a revolving wheel, like a cylindrical horse-propelled broom, but provided with rubber scrapers placed upon the cylinder like a helix. As it revolves it scrapes the mud to one side. A large motor-driven sprinkling-cart capable of throwing water to each side by means of a pump was being experimented with in 1907.

BERLIN

Another new piece of apparatus is an electrically-driven sprinkler and squeegee. The batteries are able to run the apparatus for fifteen hours without recharging. There are five forward speeds. The motors are mounted on the front wheels and are of four horse-power each.

The streets are never flushed with water from a hose, as in Hamburg and many other cities.

The quantity of water used to sprinkle the streets in 1906 was 409,000,000 gallons.

Absence of
Hose Flush-
ing

Street orderly work is done by boys ranging from fifteen to eighteen years of age. They pick up papers and brush horse droppings into piles near the gutter, using very long-handled brooms of pissava. About 40,000 of these brooms are consumed in a year. The piles of street dirt collected by the boys are not large, but they are unsightly in Berlin as they are everywhere. Sometimes a gang of two boys and a man collect the street dirt into piles and remove it at once in a hand-cart to points where it can be taken by large wagons.

Work of
Orderlies

In one street (Leipsiger), a very busy and important shopping thoroughfare, pits have been built under the sidewalk to receive the dung and avoid the necessity of storing it on the street surface. This dirt is pushed into these pits through specially constructed chutes opening through the curb. A metal pail or bucket is placed inside the pit to receive the refuse. Rain-water is kept out as far as practicable by iron doors at the opening to the gutter and the bucket is provided with holes at the sides through which the moisture can drain away to the sewer. The buckets are removed from the pits at night for

Temporary
Pits for
Street Dirt

CHAPTER XI

HAMBURG

HAMBURG, with a population, in 1906, of 802,793, is the fourth most important seaport, ranking next to London, New York, and Liverpool in the value of its commerce. It is, as its citizens are proud of saying, a free city, with a peculiar and very satisfactory form of municipal government.

The administrative departments of the city are carried on under the direction of a board, or committee, composed of the legislative branch of the municipal government. At the head of the committee is a senator who, like all the senators of this little republic, is elected for life by an elective council. Under this committee are the salaried professional chiefs.

From being one of the unhealthiest of cities, Hamburg has become one of the most sanitary. Exposed to an exceptional extent to the danger of epidemic diseases because of its extensive shipping, an admirable system of sanitary regulation has, in late years, reduced the danger of infection to a minimum.

The Regen-
eration of
Hamburg

For many years Hamburg suffered from an unenviable reputation for unwholesomeness. No less than fourteen epidemics of cholera occurred here between 1831 and 1873. An epidemic of cholera in 1892 made the city particularly notorious to Americans, for it was from Hamburg that the disease was sent to New York.

The cause of the epidemic of 1892 was polluted drinking-water taken from the river Elbe.

After years of investigation, a filter plant to purify the Elbe water was completed in 1893. Subsequently, other notable improvements were made in the water-supply, including the removal of the intake to a safer location. At the present moment, the city is developing a supply of drinking-water from wells.

The sewage of Hamburg is collected into a large tunnel or subterranean reservoir and, after careful screening, discharged into the Elbe on the outgoing tide.

At the time of the epidemic of 1892 a number of sanitary experts were called to Hamburg to help fight the epidemic and among them an American, The Hygienic Institute Dr. Dunbar. When the epidemic was over, Dr. Dunbar remained in charge of a municipal sanitary institute which the city had established. This was soon raised to a position of great importance. The work done by Dr. Dunbar and his assistants in helping to regulate the sanitary condition of the city has been of value in many directions. Not only has expert attention been given to cholera, plague, and other diseases to which the immense shipping exposes the city, but other important studies have been carried on. In no other city in Europe is the danger of epidemic disease so great and so capably guarded against.

Visitors to Hamburg are generally surprised and pleased at the ingenious way in which the water courses which pass through the city have been turned to account for purposes of convenience and pleasure. The Alster-Basin, adjacent to the business and residence districts is, in reality, an attract-
Attractive Appearance of the City

HAMBURG

ive water park occupying a place of honor such as is ordinarily given only to pleasure grounds of conventional design. This body of water, surrounded on three sides by busy city districts, is continually traversed by picturesque pleasure craft ranging from small sailboats and rowing-shells to steamers. Flocks of swans make their home here. With this central object of the Alster-Basin to stimulate the æsthetic and sanitary attention of the people, it is not strange that a large amount of care should be bestowed upon the city streets. The streets are, many of them, handsomely built, well paved, and very well kept.

The streets have been cleaned, since 1886, by the city. Formerly this work was done by the individual property holders and later by contractors under the supervision of the police. It is now a part of the work of an Engineering Bureau of the Department of Public Works.

The work of the street-cleaning department includes the cleaning of all public streets and sidewalks inside of the city limits, the watering of streets, the removal of snow and ice, supervision over the removal of street and house refuse, removal of refuse from steamers and docks, removal of refuse from city parks, and the cleaning and maintaining of public comfort stations.

Scope of
Street Clean-
ing Work

The city is divided into twelve districts, in each of which is a centrally located depot where the employees assemble and in which the necessary machines and other apparatus are kept.

Organization

There is a supply of ordinary tools at each depot and a special supply for the removal of snow and ice is kept at the main depot of the street-cleaning department. At this point also are workshops for

MODERN METHODS OF STREET CLEANING

making such small repairs to tools and machinery as are necessary. At the head of each division is an inspector who is responsible for that division. A second inspector is in charge of the night work. As the cleaning force for the streets is recruited with men who have seen military service, quartermasters and sergeants are chosen for these higher positions; for common labor only men are employed who have had good reputations as soldiers.

A night gang is composed of one foreman and 19-20 men. One man is assigned to a cleaning machine; one man to a water wagon; one to clean the street-car tracks; a small party to empty receptacles which hold the dirt collected from the streets during the day; one or two to clean out catch-basins; four to clean the sidewalks; six to shovel together the dirt which is swept into rows by the machine brooms, and four to drive the carts which remove the refuse. The night work is finished when the prescribed work for the night is done, and is therefore regulated according to the weather and condition of streets. Under normal conditions it should be finished between 8 and 9 o'clock in the morning.

Most of the street cleaning is done by machines at night. The cleaning done in the daytime is only to remove material which is most apparent to the eye.

The streets to be cleaned at the end of 1906 were 700 miles long and had an area of 9,150,000 square yards. Of this 5,200,000 square yards were carriage-ways.

The work which can be done at night depends upon the capacity of the standard one-horse sweeping ma-



Hamburg—Sprinkling-cart taking Water from a Hydrant placed beneath the pavement.



Hamburg—Street Cleaner with his Apparatus about to empty a hand-cart full of street sweepings into a temporary storage pit beneath the sidewalk.



Mud Hoes, 16 in. long. Cost in quantities, \$.39 each.



Self-dumping, Low-sided, Watertight Mud Cart used in Germany. Capacity 2.6 cu. yds.

HAMBURG

chines. These, working eight hours, can sweep about 115,000 square yards. Since there are in the 12 departments, 26 sweeping machines, there are cleaned each night about 2,990,000 square yards of pavements.

The sweeping begins at 11 o'clock at night. If necessary the streets are sprinkled with water to keep down the dust.

The street cleaning which is done in the daytime is carried on by gangs of one foreman and four men. The working hours are from 6 in the morning until 6 at night, with a rest of two hours.

Squeegees are used a great deal in keeping asphalt and sidewalks clean. They are of special service in rainstorms, advantage being taken on such occasions to clean the sidewalks and flush the street dirt into the gutters.

Asphalt

In cleaning asphalt under ordinary circumstances, a large quantity of water is first sprinkled by wagons, and later men with brooms and squeegees work energetically to push the refuse into the gutters.

The principal streets are sanded constantly by men called orderlies who are especially assigned to picking up refuse and sanding during the day. The orderlies have small carts which they push with

Work of
Orderlies

one hand and with the other sprinkle the gravel with short-handled shovels as they walk. The gravel is large and as sharp as it is practicable to obtain. A few minutes after the gravel has been sprinkled upon the pavement, horses and vehicles crush the large particles into small gritty circles which gradually expand and cause the sharp pieces to spread over the street. The fact that sand has recently been sprinkled upon a street does not prevent the use of squeegees or brushes

whenever they seem needed in order to carry away accumulations of dirt.

The refuse collected from the principal streets during the day is put into pits having a capacity of 2.6 cubic yards placed beneath the sidewalk. There **Underground Pits for Street Refuse** were, in 1907, 190 of these temporary storage-bins. The pits are emptied at night, washed out and disinfected. Each street in the city is cleaned at least once a week at night and twice a week in the day. Owing to their importance, many streets are cleaned nightly during the week and four times each day. On an average about one-fifth of the total street area is cleaned by the night-cleaning force once a day and the rest from once to twice a week. In addition the coarse refuse is removed by hand from two to four times per week.

The asphalted streets receive special care. To keep them looking well in the daytime the main streets are divided into posts, each about 650 to 3250 feet **Posts for the Orderlies** long, giving an area for each man to keep clean of 2160 to 15,600 square yards. At present there are forty-nine posts for about 266,000 square yards of asphalt. On Sundays and week days from 6 in the morning until 7 in the evening the men at these posts have to remove the visible refuse and sand the streets after they are sprinkled.

The sand used upon the streets is, in reality, hard gravel composed of particles as large as three-fourths of an inch in diameter. It is kept under the pavement in special pits holding 2.6 cubic yards each. **The Sand Used on the Pavements** At the present time there are 21 such compartments.

The asphalt is thoroughly flushed at night by hose

HAMBURG

attached to a hydrant. This has proved the best and cheapest way to clean the asphalt of the dirt which cannot readily be removed by sweeping. Cleaning with water wagons and rubber squeegees and by sweeping machines with rubber scrapers has not proved so satisfactory. The cost of cleaning 1000 square yards of asphalt by flushing, after the Hamburg method, is about 17 cents in Hamburg.

The sprinkling of public streets to keep down the dust in the summer is done by one-horse water wagons. Each wagon holds about 400 gallons. These wagons are filled direct from hydrants and Sprinkling sprinkle water from fine holes. A wagon during nine hours work requires to be filled forty-four times and can sprinkle 120,000 square yards a day.

Most streets are sprinkled at least twice a day, but on the very small or very shady streets once is sufficient. On very hot and dusty days, by prolonging the service until 9 o'clock, many streets are sprinkled three times. Some sidewalks in much frequented public places are sprinkled by the city by means of hand water wagons, but generally the citizens sprinkle the sidewalks in front of their own houses. For this privilege property holders pay a certain amount for the use of water.

An important part of the work of the street-cleaning department is the removal of snow and ice. For this purpose each one of the twelve districts is sub- Snowdivided into ten snow divisions. As the regular force of the street-cleaning department is not sufficient for the whole work, special workmen to the number of about 326, belonging to the engineering department and about 2300 laborers, are called on to

MODERN METHODS OF STREET CLEANING

help. These men are distributed among the different snow districts. The number of men in each snow district is, according to the height of snow, from 20 to 50. The men are all required to report when snow falls at a special place in the district. The more intelligent workmen of the street-cleaning department are appointed foremen and held responsible for the proper working of the force under them.

In removing snow the first thing to attend to are the sidewalks. It is necessary to clean sidewalks in front of private houses, business places, and unoccupied lots. At the same time the snow is removed from the street-car tracks to keep them in working order. Meanwhile snow ploughs and sweeping machines work day and night to remove snow from the center of the streets to the curbs, where it is piled up and removed. The snow is removed in iron carts, of which there are 740, each holding 0.6 cubic yard, and wooden wagons of 2.6 cubic yards capacity, of which 260 are temporarily procured by contract.

The snow is carted away by men who receive, according to the length of haul, from 23 to 42 cents per load. The dumping places for each district are selected beforehand, and consist of spaces in the public parks, vacant lots, and water courses where there are strong currents. When a thaw sets in these dumping places are thoroughly cleaned and all residue that is left removed.

The laborers receive 8 cents per hour and are paid every night at the depot. The drivers are paid monthly. The daily paying is done by fifteen paymasters especially employed for the winter. They furnish \$238 security. The cost of the removal of snow differs according to the amount of snow which falls. The

HAMBURG

average for the fifteen years, 1892 to 1906, has been \$59,911. The average cost per day when the full force is at work is \$4770. The workmen wear a convenient and suitable uniform.

The final disposition of the refuse collected from the streets during the day and night is let by contracts running five years at so much per thousand inhabitants. The contractors supply their own wagons. They receive \$57 to \$65 per thousand inhabitants. The refuse is the property of the contractors. They are not allowed to dump or dispose of any refuse inside of the city limits. Outside of the city limits the refuse must be burned or used as fertilizer. The contractor must supply, according to the weather, enough wagons to have all street dirt removed between 11 o'clock in the evening and 7 o'clock in the morning. Only during especially severe weather when it is particularly difficult to remove the refuse is the time extended. A fine of 48 cents per wagon load may be imposed for not living up to this part of the contract.

Final Disposition of Street Refuse

The work of removing house refuse is also let by contract lasting five years at a specified sum per thousand inhabitants. At present this rate is \$107 to \$113 per thousand inhabitants a year when the refuse is taken to the refuse destructor and \$131 to \$132 when it is removed to the country.

Removal of House Refuse

The refuse is placed by the householders in cans and these are put in front of the houses on the days for collection. From April 1 to September 30 the cans are not put out before 10 P.M. and from October 1 to March 31 not before 9 o'clock in the evening. The cans are taken in again after 8 o'clock in the morning.

MODERN METHODS OF STREET CLEANING

The removal of household refuse begins at 11 o'clock in the evening and must be finished by 7 o'clock in the morning. In special districts as well as in dealing with the public hospitals, this removal takes place seven times a week, but under most circumstances it is removed three times, and sometimes only twice a week.

In removing this house refuse from certain parts of the city containing about 356,000 inhabitants, covered wooden wagons are used, holding about 8.2 cubic yards. The material removed is the property of the contractor and must be destroyed at once under penalty of fine. It is strictly forbidden to pick over this refuse. In other parts of the city with about 457,000 inhabitants, the refuse is removed in iron wagons of 4.8 cubic yards capacity to refuse destructors and there burned. The refuse collected at public markets is also burned.

To prevent the transmission of infectious diseases by rats, refuse from the docks is collected in special iron wagons fitted with locks. This material is burned twice or three times a week. The collection of these matters produced on steamers is conveyed by electric boats to the burning plant. A special description of this plant is given in a book called "Die Stad-tische Verbrennungsantalt für Abfallstoffe am Baller-deich in Hamburg," by F. Andrew Meyer, the late Chief Engineer, published by Friedr. Wieweg & Sohn, in Braunschweig, April, 1901, second edition.

There are not many refuse burning works on the Continent and, as the works at Hamburg are among the best as well as the largest in the world, a few words of description may be of interest concerning them. The process is essentially the same as that frequently seen in England, although

**The Hamburg
Incinerator**

HAMBURG

the character of the refuse handled appears to be somewhat different. The refuse destructor belongs to the Horsfall type and strongly resembles a plant at Brussels which has been more recently constructed. In round figures the Hamburg plant destroys the household refuse of about half a million inhabitants, as well as much refuse from ships and markets. Fluctuations occur in the quantity of wastes handled up to 50 and even 100 per cent on some days. The operation of burning reduces the refuse to about 59 per cent of its original weight. This differs considerably from the results obtained in England where the clinker and ashes are usually reckoned at about 33 per cent of the weight of the refuse before it is burned.

The works are situated on the outskirts of the city and appear to produce little offense on account of odor. Work was begun on the construction in 1893 and finished in 1896. The cost was about \$120,000, not counting many improvements and alterations which have been made from time to time.

In the street leading to the works there is a weighing machine which is used by the management of the destructor to collect data concerning the quantity of the refuse which is carried from the houses to the works. After being weighed the wagon enters a passage which crosses the furnace room at its northern end. Here the wagon body with its load is elevated by means of one of two electrically-operated cranes and conveyed to a platform overhead, where it is mechanically dumped in a position convenient to the feed hoppers of the furnaces.

The furnaces are contained in a two-story building of iron framework with roof of sheet iron. The building

Arrangement
of Refuse-
burning
Works

is divided into two symmetrical parts, each lateral half containing eighteen furnace cells. These cells are situated below the central platform on which the refuse is dumped from the wagons. Each half is entirely separate from the other and can be worked independently.

The tipping platform occupies the whole width of the building except a long, central opening, about 2.72 yards wide, which serves for ventilation. The capacity of the platform is sufficient to permit of the conveyance and management of the wagon bodies and some temporary storage of refuse when the plant is operated at its maximum capacity. A single cell is capable of consuming daily an average of 357 tons per day.

The cells are fed at intervals of about $1\frac{1}{2}$ hours through hoppers in the platform. The cells on the opposite sides of the buildings are placed back to back beneath the tipping platform and have a common feeding hopper. One workman can feed about six cells. The refuse, which is fed through the hoppers from the platform, falls upon the front of the drying hearth of the furnace after which it is spread over the grates and burned.

The Incinerator Cells

The cells are stoked by attendants below through two-winged furnace doors. The attendants use special iron feeding tools with which they distribute the refuse over the grate to assist the combustion. One man can serve three furnaces in this way. A large part of the success of the process depends upon the efficiency with which the stoking is performed. The grate upon which the refuse is burned has an inclination of 1 to 4.

HAMBURG

The necessary amount of air for combustion is furnished by two electrically-driven blowers which act under a pressure of about 40 to 50 mm. of water column. The air enters directly over the clinker doors of the furnaces and communicates with a common suction pipe so that smoke and dust are carried away at this point. The air is somewhat warmed before it reaches the fire. The quantity of air can be regulated through valves placed in front of each furnace. Electric bells communicate and afford opportunities for signalling between the stokers and the men who feed the refuse into the hoppers.

The exhaust products of combustion and fumes from the drying hearth enter a second chamber over the furnace arch. The walls of this chamber are kept at a temperature between 500° and 100° C. Here the imperfectly burned gases and fumes are consumed by the red-hot walls, so that an escape of odors into the atmosphere is avoided.

The inoffensive gases finally pass through horizontal and then vertical flues fixed between the furnaces which carry them to a central chimney 160 feet high. The fine dust and ashes which are carried out of the furnaces lodge in the main flue and final combustion chamber from which they are removed from time to time. The combustion chamber is usually cleaned at intervals of about three days and the flues about every three months.

The ashes and clinker left in the main part of the furnace after the refuse is burned, consisting of about 59 per cent of the weight of the original refuse, is withdrawn in specially designed tipping wagons. A slight

layer of red-hot refuse is always left upon the grate when the ashes are removed and upon this the following load of fresh refuse is deposited. Under these circumstances the contents of the ash wagon, when the work is well done by the laborers, is about 361 pounds. Flues are arranged so that the heated gases may be directed up the chimney or under steam boilers for the generation of power.

Use of
Ashes and
Clinker

The burned waste matter is first transported to a railroad siding and then to a separate part of the works where it is cooled with water, ground up and sifted. The ground clinker is sifted in a drum-shaped screen, which is provided with holes of different sizes. The material which is thus separated is caught in funnels and conveyed to wagons placed beneath. About 16 per cent is very fine, 50 per cent of medium size, and 34 per cent of coarse consistency. The metallic substances are separated from the clinker and sold. The dust from the flues is sold for the making of artificial sand, and for other purposes. The ground clinker is used for building purposes in place of broken stone and gravel. At times the work of building is so active that the production of ground clinker scarcely meets half of the demand.

Power is generated from the heat of the burning refuse by means of four boilers. The temperature of the gases which reach these boilers ranges from 450° to 760° C. and averages about 600°. The steam is used for running the machinery necessary to operate the plant, for a small amount of heating on the premises, and for the production of electric power which is transported and consumed in other parts of the city.

Generation of
Power from
the Refuse

HAMBURG

The consumption of power at the works is chiefly for the operation of the cranes which lift and dump the refuse wagons, for the machinery which grinds up the clinker, for blowers which facilitate combustion, for certain small pumps, and for illuminating purposes.

The electric current produced by the burning of refuse in this plant in 1906 was used subsequently for the purposes and in the amounts specified below:

At the refuse destructor: 13 motors, consuming 400,400 kilowatts annually; 18 arc lights and about 150 incandescent lights, 63 kilowatts annually.

On the electric refuse boat: 10,000 kilowatts annually.

For the city sewers: 4 motors, couples, with a centrifugal pump; motors for 2 air pumps; 2 motors for use in connection with screens for removing coarser solids from the sewage and for incandescent lights; 486,200 kilowatts annually.

For the city water works: 8 arc lights and various incandescent lights; 1500 kilowatts annually.

For a private consumer: for 1 motor, 3100 kilowatts annually.

Total, 964,200 kilowatts annually.

The utilization of this power brings in a certain return annually. The quantities of refuse consumed each year and the average performance of a single burning cell per day are given in the following table:

Quantities
of Refuse
Burned

MODERN METHODS OF STREET CLEANING

Year.	Refuse Burned, U. S. Tons.	Average Performance per Cell per Day, U. S. Tons.
1896	50,343	7.12
1897	54,416	7.45
1898	55,161	8.13
1899	56,124	8.22
1900	58,207	8.02
1901	61,007	8.22
1902	76,546	8.58
1903	75,963	9.21
1904	84,334	9.69
1905	89,408	9.52
1906	91,709	9.91

This refuse was derived from the following seven principal sources:

81,698	U. S. tons	house refuse	
395	“	market refuse	
4,656	“	dock refuse	
3,678	“	ship refuse	
1,074	“	refuse collected by the city and private parties	
38	“	refuse of other places	
<hr style="width: 10%; margin-left: 0;"/>			
Total	91,536	“	

The refuse destructor requires the employment of about 100 workmen. They work in shifts of eight hours each. The plant is operated continuously except from 6 o'clock Sunday morning to 6 A.M. on Monday. When the plant is closed down the drafts are reduced as much as possible and an effort is made to retain the heat. On Monday when operations are resumed, a small amount of fuel is sufficient to bring the temperature to the normal, raise steam, and set the plant in customary operation.

HAMBURG

The health and comfort of the men are cared for by various sanitary measures, but the process of burning the refuse produces in spite of these precautions a considerable amount of dust and unpleasant odor locally. In the basement near the entrance of one of the buildings are rooms where the men may bathe and dress, and it is said that each man customarily takes a bath at the end of his shift. In order to avoid the injurious effects of excessive water drinking in summer, pure coffee is prepared by means of a steam operated cooking apparatus. Two cocks are fitted through the side of one of the buildings in the open air and here the men fill their drinking vessels at will.

Care of
Laborers

Besides the work done under the regular jurisdiction of the city, the street-cleaning department is responsible, according to a law which went into effect March 1, 1900, for the cleaning of certain property which belongs to the city but which lies outside of the city limits. This property consists of low-lying building lots. These must be emptied of their accumulated water with suitable apparatus.

Extra Work
Done by
Street Clean-
ing Depart-
ment

Horses and drivers are hired for the street-cleaning department on a five-year contract which began on January 1, 1906. The rate of \$1.09 to \$1.49 per horse per day and \$.95 to \$1.41 per driver per day of nine hours continuous work, or at night until the work designated for the night is finished.

Cost of
Horses

In 1906 the number of men employed was 753. The quantity of refuse removed from the streets was 177,000 cubic yards and from the houses 169,800 cubic yards.

Quantities
and Cost of
Labor

The expenses of the whole work of street cleaning

MODERN METHODS OF STREET CLEANING

for the year 1906, exclusive of that for removing snow and ice, amounted to \$468,414. Of this, \$52,037 was paid for removing refuse from the streets and \$94,110 from the houses.

The equipment included, beside the wagons used for transporting the refuse collected from the houses to
Plant the refuse destructors, 48 iron wagons for transporting the refuse collected at docks, 11 Kubel wagons, 3 pneumatic pumping apparatus with a tank wagon, 1 gasoline motor-boat, 1 electric boat, and 2 scows for removing the refuse collected on steamers, 47 sweeping machines, 91 water wagons, 20 hand water wagons, 117 tool stations, 48 iron snow ploughs, 21 wooden snow ploughs, 789 iron snow carts, and 357 iron refuse wagons.

CHAPTER XII

COLOGNE

COLOGNE, with a population of 428,722, is situated on one of the banks of the Rhine near the French frontier of Prussia. The city is of remote origin, having been founded before the Christian era.

Cologne now belongs to Germany, but in some respects it is more French than German. It is one of the most cosmopolitan of cities, a result partly due to its location, and partly to the fact that Cologne ranked for centuries as a separate state carrying on a large trade with foreign countries and particularly with England.

Until recent times Cologne was as famous among travelers for the unpleasant odors of its streets as for the delightful perfumes which were to be carried away in bottles. A clever Englishman once said that the three dirtiest cities in the world could be found under the letter C; they were Calcutta, Constantinople, and Cologne. For many years cramped and badly crowded within a system of powerful fortifications, the congested condition of the city undoubtedly merited the unenviable reputation which travelers gave it. Coleridge's lines in regard to the sanitary condition of the city are familiar to all:

"The river Rhine, it is well known,
Doth wash your city of Cologne;
But tell me, nymphs, what power divine
Shall henceforth wash the river Rhine?"

And again:

“I counted two-and-seventy stenches,
All well defined, and several stinks.”

In 1881 the old fortifications were abandoned and their place taken by new and handsome streets. Since then the area of the city has more than doubled, and extensive municipal improvements have been made. The city is now sewered and possesses one of the most recent and approved systems of sewage disposal of any similarly situated place in Germany. This system is very simple. The sewage is screened and passed through a sedimentation basin before it is discharged into the Rhine.

Much of the old part of the city is given up to handsome shops and cafés. After the custom of Holland, the principal thoroughfare is crowded from house line to house line with promenaders after nightfall.

The history of the development of the present system of street cleaning (which is remarkable chiefly as affording an example of good German practice) shows so well the experience of other European cities that a short account of it will be given here. It will be observed that the sanitary history of Cologne is being repeated with certain modifications in many cities of the United States to-day.

At the beginning of the sixteenth century, when Cologne was an independent city and one of the wealthiest and most prosperous commercial centers in Europe, official attention seems first to have been directed to the insanitary condition of the city. Filth lay in heaps in front of the houses on both sides of the streets. The few open spaces but served to make the air more foul rather than to clean

Condition of
City Streets
in very Early
Times



Antwerp—Cart Collecting House Refuse. Householders help the collectors by carrying refuse to the carts.



Odorless Metal Cart used at Cologne.



Antwerp—Boats for carrying City Refuse to the Country to be used for agricultural purposes.

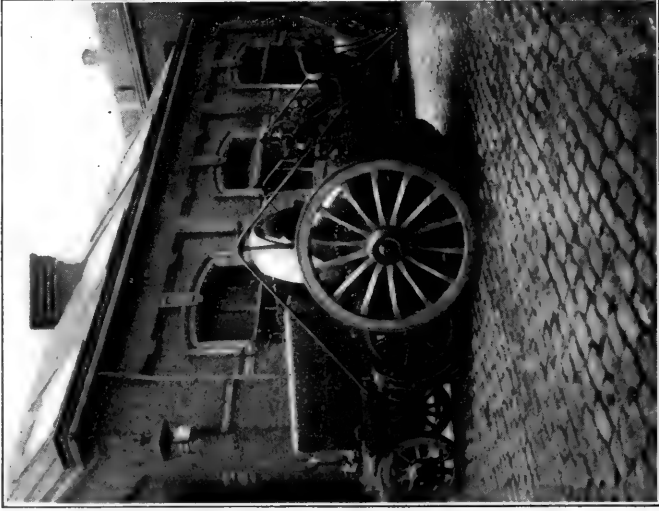

Antwerp—Sprinkler, Sweeper, and Collector for Street Dirt.

and freshen it, for masses of dirt and rubbish of all sorts was allowed to accumulate there. In the market places drains were placed to carry liquid refuse from watering-places for horses and cattle, but these were often obstructed. Nor did only street dirt and household refuse accumulate in the thoroughfares: the bodies of dead animals were thrown into the streets and allowed to remain there indefinitely.

The conditions were favorable for the propagation of rats, flies, mosquitoes and other carriers of disease germs. There needed only the specific germs to precipitate epidemics. It is not strange, therefore, that until the middle of the seventeenth century, when the independence of the city was lost and Cologne was subjected to a thorough house-cleaning by the French, that disease, and especially plague, often raged in Cologne. In the year 1503 no less than 20,000 people died of plague here. In 1540 there were 200 deaths a day, and in the two years of 1665 and 1666, the deaths numbered 11,403.

Insanitary
Conditions
Favorable to
Epidemics

The city council had, in the fifteenth century, made a futile effort to establish a regular system of removing filth from the streets. An agreement was made with two peasants whereby each should maintain a good horse and cart and, moving from street to street, carry, without payment from the individual citizens, all ordinary dirt and rubbish from the streets to the river. The result was unsuccessful, as might to-day be expected, considering the inadequacy of the force. The city decided to abandon this plan of cleaning the streets and passed numerous ordinances aimed to punish citizens who threw their dirt before the doors or neglected to remove refuse from their property. But the

frequency of these orders or ordinances as Ennen,* our authority, rightly observes, shows that the inhabitants concerned themselves little about them.

In the year 1587 there was no longer a city system for the removal of refuse. The head of each family was supposed to be held responsible for the removal of the household refuse to the walls of the city under penalty of a golden florin. One hundred years later the records of the council show that accumulations of refuse still existed in the streets. Now, however, certain men were engaged by the city to do the cleaning at the cost of the persons most benefited.

It was the injection of French spirit and enterprise which finally brought about conditions in some degree tolerable. Under the influence of the French at the time of the seven years' war, the council provided for the lighting of streets and, under date of September 6, 1761, for the first time established definite times for cleaning the streets and removing the refuse. The council decreed that all refuse should be set out convenient for removal on Wednesdays and Saturdays at 6 P.M. from April to September and at 4 P.M. from October to March under penalty of 10 stivers. Refuse was not under any circumstances to be swept into water courses and gutters. The cost of the work was to be properly proportioned for each neighborhood. The refuse was to be carried to a heap in each district and from there taken out of the city each Monday by carts.

In 1789 a law appeared which contained general

First Impulse
for Clean
Streets

* Description of the City of Cologne.

regulations for the community. Among other things the citizens were held responsible for the removal of the street refuse. In accordance with this law the mayor issued in 1801 an order concerning street cleaning which is the foundation of the system of the present day. The groundwork of this order was as follows:

Basis of
Present
Methods

1. The inhabitants were obliged to clean and sweep the streets before their houses or property to the middle of the street and to pile up the dirt in order to facilitate removal.

2. Rubbish from the houses must be collected in baskets or tubs and carried to the carts which were provided for the removal of the refuse.

3. The contractor for street cleaning must promptly remove the accumulated street dirt as well as the rubbish collected from the houses.

This order was important in that it fixed the limits of the duties of the citizens and those of the city as a whole. The sweeping was made the duty of the inhabitants and the actual removal of the refuse the business of the community. Moreover, this order for the first time provided for the removal of house refuse. Previous orders had simply provided for the removal of dirt from the streets.

In later orders, the owner of the house and, in doubtful cases, the inhabitant of the ground floor, was made responsible for the cleaning. Instead of twice weekly, daily cleaning was initiated. In a police ordinance of June 4, 1889, the owners of unbuilt real estate were required to keep the same clean. Finally, by an ordinance of November 3, 1892, the orders which had covered only Old Cologne were

extended in like manner over the whole of the greater city.

The state of cleanliness has greatly improved in the last century in comparison with earlier times, but the words of Ennen that the inhabitants were concerned but little about the removal of street refuse still hold good for Cologne and most other cities. The citizens sweep only the sidewalks and gutters, and not the carriageways. Even the former work is done very imperfectly.

To better the situation, the cleaning of the principal streets was given over to a contractor in 1860, and in 1871 it was recommended that the sweeping of all streets be performed in this manner. In 1873 it was proposed that the streets be swept by the city. In 1881 and 1882 this matter again came up for consideration in connection with the establishment of a city trucking department. From that time on this question remained open until the end of the year 1890 when a city trucking department was established.

The regulations then made and others which followed in 1895 brought much opposition from the citizens. The necessity of changing the general method of street cleaning arose on the one hand from a deficient state of cleanliness and on the other from the removal of the fortress walls which had surrounded Cologne and the rapid development of the town to a large city. In this new city broad streets with improvements, such as roadways separate from sidewalks, were begun. The cleaning of these streets could not have been accomplished by the individual inhabitants. In the interior of the city where the traffic was greatest and travel on the

Personal Un-
concern of
Citizens about
the Condition
of Streets

Popular Op-
position to
Thorough
Cleansing
Methods

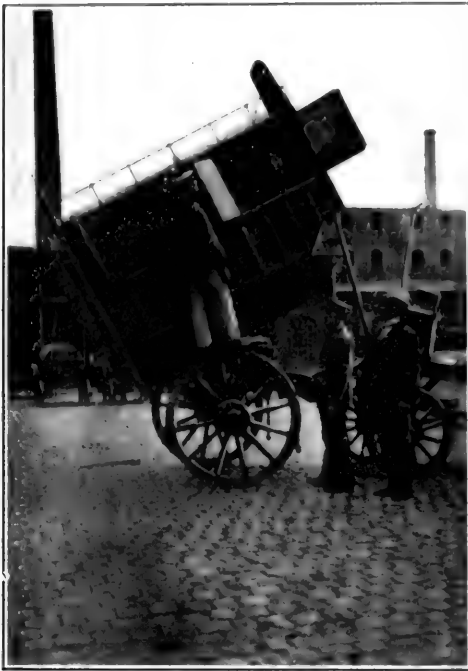

Closed Wooden Cart showing Openings with Doors to prevent Dust and method of Dumping—Cologne.



Excellent Type of Metal Dustless Dumping Cart used at Antwerp.

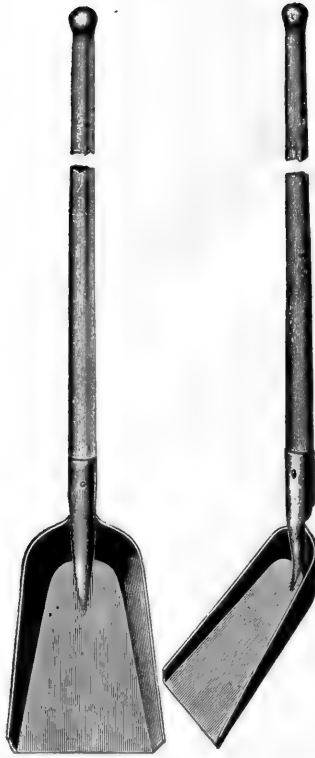

Snow Shovel, 16×10.6 in. Cost in quantities, \$.38 each.

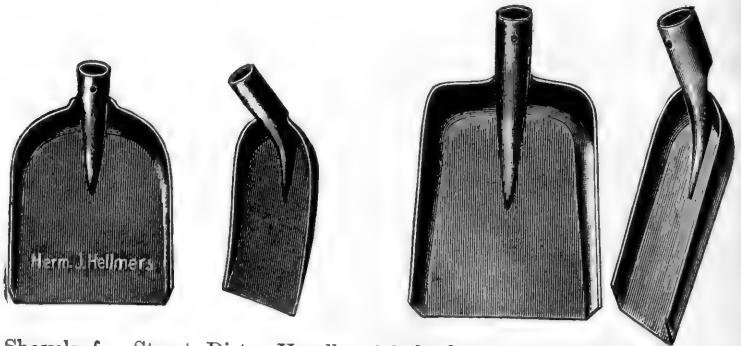

Shovels for Street Dirt. Handles 4.6 ft. long, 11.5+9.6 ft. Cost in quantities, \$.31.

COLOGNE

streets increased from year to year, wood and asphalt pavements, especially the latter, were laid. The proper cleaning of this kind of pavement by the innumerable separate owners of the abutting property was not possible. It had to be accomplished throughout in a uniform and efficient way. The growing traffic as well as the requirements of modern hygiene demanded that the principal cleaning be no longer done in the day but at night.

By June 1, 1890, the principal cleaning was done by city workers as was also the removal of the street and house refuse. At the same time a city transportation department was established. In the following year jurisdiction over the streets was extended until by April 1, 1891, the cleaning of the whole city, old and new, was in the hands of the street cleaning department. The sweeping of the principal streets and the whole process of collecting and removing refuse has been done by the city since April 1, 1900.

Two separate bureaus, each under the management of their own chiefs now coöperate to remove the refuse and clean the streets. The transportation bureau employs about 180 men, has 160 horses, and 190 wagons and carts. The street-cleaning department employs about 310 men, has over 20 horse-propelled rotary brooms, 35 sprinkling-wagons, 90 hand-carts, and other apparatus.

Organization
of Street
Cleaning
Forces

The horses, wagons, and tools of the street-cleaning department have headquarters in three large depots. The principal depot, with the offices and dwelling of the chief and his immediate assistants, is in the western part of the city. Here 100 horses and a corresponding number of wagons are kept. In the northern and

MODERN METHODS OF STREET CLEANING

southern parts of the city are depots with stable room for 30 horses each and the necessary appurtenances.

The transportation bureau affords accommodation for the horses used by the fire department, sprinkling-wagons, sweeping machines, wagons for street and house refuse, mud wagons, and wagons for the removal of snow and market refuse. This bureau carries the coal, coke, and wood for all city institutions: schools, government buildings, hospitals, and municipal water and electric-light works; it hauls building materials and stone for the pavement.

While this work is accomplished by the regular men of the department, this force does not suffice when much building work is being done by the city. Under these circumstances the transportation bureau increases its means of conveyance.

The calculation of all details of cost of the work of transportation and the settling of accounts with city institutions takes place monthly or quarterly by the transportation bureau.

The street-cleaning bureau in coöperation with the trucking bureau does the following work: Sweeping; removal of street refuse; removal of house
**Work of the
Street Clean-
ing Bureau** refuse; cleaning of markets, including the removal of market refuse; cleaning of sewer catch basins; cleaning of the property of institutions; cleansing of carriageways, and especially of narrow streets and corners of houses exposed to soiling; sprinkling of streets; removal of snow.

Street wells and pumps are under the control of the street-cleaning department. The water of many of the wells is dangerously polluted and these wells are

COLOGNE

closed and provided with signs notifying the citizens that the water is not fit to drink.

The inspectors of street cleaning are charged with the inspection of everything which relates to the cleaning of the streets so that defects in street work of all kinds may be plainly pointed out and set right.

Of the workmen in the street-cleaning department, sixty have been trained in the disinfection of dwellings and are detailed, when required, to the city disinfecting establishment. In this way the danger of outbreaks of epidemic disease is lessened.

For the work of street cleaning the city is divided into eight cleaning districts. Each one of these has a depot with office rooms and dwellings for the district chiefs or inspectors, tool rooms, and shelter rooms for the laborers. These shelters have been provided with arrangements for heating and for cooking by gas so that the workmen can rest here comfortably and cook their coffee. All depots, including the depots of the transportation department, are in telephonic communication with one another by day and night.

Division of
the City into
Districts

Five places have been provided in the suburbs for the reception of refuse. These receive annually about 2,500,000 cubic yards of refuse.

The force includes 1 superintendent, 15 overseers, 15 assistant overseers, 1 chief foreman for the wagons, 5 foremen, and 10 assistant foremen; 478 street cleaners and 220 drivers. Of the latter 73 are employed for the removal of house refuse. The total area of paved streets in 1907 was 4,181,346 square yards divided as follows: Asphalt, 209,365 square yards; wood pavement, 7595 square yards; stone pavement, 2,616,242

MODERN METHODS OF STREET CLEANING

square yards; macadam, 951,787 square yards; gravel, 394,482 square yards; other material, 6822 square yards.

The frequency of the collections and the quantities of refuse removed from the streets in 1907 are shown in the following table:

		PRINCIPAL CLEANING (AT NIGHT)	
<i>Roadways:</i>			Sq. Yds.
Stone pavement:	Swept six times weekly with machines		835,101
	Swept three times weekly with machines . .		953,989
	Swept twice weekly with machines		677,636
Asphalt:	Washed six times weekly with machines and rubber squeegees		227,047
<i>Sidewalks:</i>	Swept or washed six times weekly		1,191,364
			3,885,364
		DAY CLEANING (ACCUMULATIONS DURING DAY)	
<i>Roadways:</i>			Sq. Yds.
Stone pavement:	Collections four times daily		2,157,380
	Washed twice daily, collections continued . .		226,472
Macadam:	Collections twice daily		311,791
<i>Sidewalks:</i>	Swept or washed four times daily		1,511,349
			4,206,972

Allowing seven hours working time per day or night, the performance of a sweeping machine in this city amounts to 8903 square yards per hour. The standard machine is that made by Hentschel & Son, Berlin. The principal cleaning with the sweeping machines, the removal of street and house refuse, and the cleaning of the sewer catch basins takes place at night.

The principal business streets are swept six times, and others three times a week, with machines. Those which are swept with machines only three times each week are cleaned with hand-brooms on the remaining days. Besides this, a general sweeping with hand-brooms takes place on Mondays and Fridays.

Frequency
of Street
Cleaning



Hand Brooms of Piassava. The larger kind is used to sweep together the throw of sweeping machines. It is 18.8 in. long and, in quantity, costs, with handle 5.9 ft. long, \$.55 each. The smaller is 14.8 in. long and costs, with handle, \$.31. It is used to sweep refuse, onto a shovel.

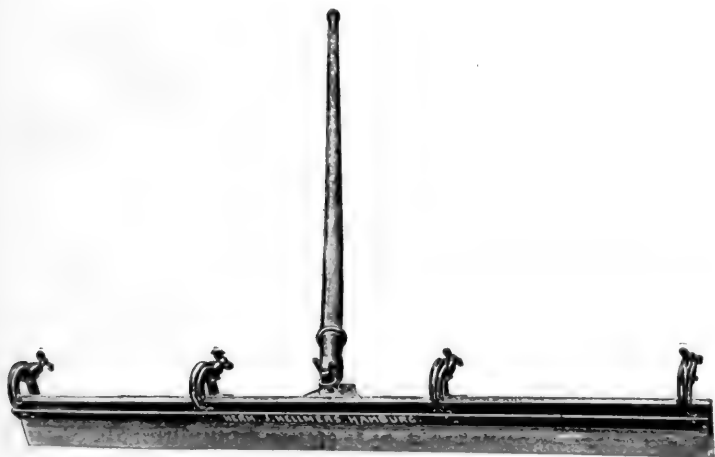

Hand Squeegee with Adjustable Rubber Edge. Length of edge 3.3 ft.
(Cost \$5.60.)

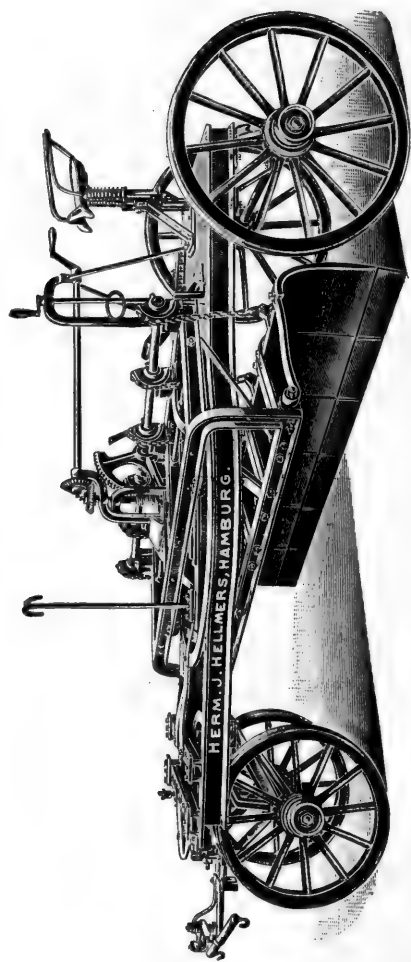

Snow Scraper, for two horses, used in many German cities, including Berlin, Hamburg, and Frankfurt. This machine can instantly be adjusted so as to throw the snow to left or right. Scrapes a path 7.2 ft. wide and cleans about 9560 sq. yds. of pavement per hour. Costs \$216.

COLOGNE

In the daytime a number of the youngest and most agile workers are distributed upon the streets to remove such litter as can be collected by them. These workers collect the refuse in hand-carts. The carts are emptied into pits of about 2.6 cubic yards capacity each, located beneath the pavement. There are 45 of these pits. They are emptied every night and cleaned.

Day Clean-
ing

Just before being swept the streets are sprinkled by sprinkling-wagons. In 1907 the area sprinkled in the day averaged 2,393,403 square yards. For this 55,582,000 gallons of water were required. The amount of water used for sprinkling preparatory to sweeping 1000 square yards of stone pavement averages 130 gallons, for washing asphalt 150 gallons, for cleaning with hand-brooms 15 gallons. The sidewalks are watered at the same time by hand. In the daytime, hand watering is also employed. The street refuse is removed immediately after the sweeping machines have finished their work.

House refuse is called for at all the houses in the city and brought to the dumping place at least three times each week. The collections begin at 10 o'clock at night. The total quantity removed in 1907 was 180,217 cubic yards, weighing 1322 pounds per yard.

The Collec-
tion of House
Refuse

Following the demands of hygiene, a so-called "dust-free" refuse wagon has been introduced for the removal of refuse. This wagon is intended to prevent the escape of dust when the refuse receptacle is being emptied and subsequently. The cost of removing house refuse amounted to \$32,932 in 1902. The sweeping of markets takes place daily at the close of business, which is usually

about 2 P.M. at certain times, that is, on principal market days, as many as sixteen wagons are required for this work.

The cleaning of the sewer catch basins, of which there are about 7000, is accomplished by special gangs, one in each cleaning district. The mud wagons used in removing this refuse are of iron and of 1.9 cubic yards capacity. The cost of cleaning each basin is reckoned at \$1.66 for the year. Of this \$.95 are charged to the Board of Works and \$.71 to the department of street cleaning.

The cab stands and numerous narrow alleys are washed regularly once, and sometimes twice, a week, in summer.

The streets are sprinkled in the day from April 1 until October 1. All the principal streets are sprinkled, including those of the suburbs, by sprinkling-
Sprinkling wagons. The carriageways and sidewalks of other streets are sprinkled by means of hose carried from place to place on reels or drum carts. Three different kinds of sprinkling-wagons are used:

1. Wagons with turbine pumps for the broad streets of the new city. These wet a path 11 yards wide.

2. Miller's patent wagon for the wider streets of the old city. These have a capacity for wetting a path 8 yards wide.

3. Wagons with rose sprinklers for the narrower streets. These have a capacity for sprinkling a path 6 yards wide.

The area sprinkled daily, including night sprinkling, amounted to 2,393,403 square yards in 1907.

For the removal of snow, the eight cleaning districts are each divided into eight subdistricts. Each of these

COLOGNE

snow districts has a foreman appointed from the force of regular laborers, and extra workmen are employed. Four wagons for hauling away the snow are assigned to each gang. In all there are 56 snow districts. The work is begun simultaneously on the principal streets. After this the other streets of the districts are freed from the snow in regularly prescribed order.

Snow

The wages of the extra men are 7 cents per hour. The removal of 1000 cubic yards of snow costs about \$84. The carts are provided with tally cards which have the numbers of the subdistricts running from 1 to 20. The carts after being loaded and before starting for a dumping place have their cards marked, and upon discharging their loads, have them marked again. From these tallies the work done is calculated.

The load cards and the working cards of the laborers are provided with the signatures of the holders and serve as vouchers, so that special accounts need not be opened.

Most of the snow is dumped into the Rhine. There are seven dumping places on the wharves and seventeen elsewhere.

The whole cost of street cleaning (including that of day sprinkling, \$11,042) amounted in the year 1902, to \$152,026. There was an income from various sources of \$14,679.

Cost of Street
Cleaning

The house refuse is hauled by the transportation bureau out of the city in covered wagons. Formerly, the sweepings were piled in heaps at the dumping places and conveyed finally to agricultural fields. Up to 1897, the chief dumping

Final Dis-
position of
Refuse

place was at a certain railway terminus. From here four railway cars were sent each day to distant villages. This railway terminus was finally abolished, and it has not since been possible to make a similar arrangement.

Purchasers can be found for only part of the refuse at the city dumps. With the building up of the suburbs, the dumping places have been pressed farther and farther away and this has raised the cost of removing the refuse. Complaints of noxious insects and of offensive odors grow more and more so that now suitable places for dumping can hardly be found. These difficulties have caused the city, especially since the establishment of the Hamburg plant for the burning of refuse, to inquire into the question of incineration. Trials have been made with several carloads of Cologne house refuse in the Hamburg plant. These trials have resulted favorably. On this ground a committee was finally appointed to visit different burning plants in England and other plants for the disposal of refuse. This committee favored the installation of a refuse destructor in Cologne. The following conclusions show some of the principles which this city committee believed were correct in dealing with this important question.

As to the means by which the refuse could be made to generate heat in an incinerating plant, the committee's judgment favored only the newest and best works. In the older plants of England the utilization of the heat had not been considered by the designers and the newer works, therefore, showed better worth in this respect. The value of the heat which could be procured from burning the refuse of Cologne was estimated to average one-eighth the value of coal. Accepting the fact that

Studies of
Refuse De-
structors.

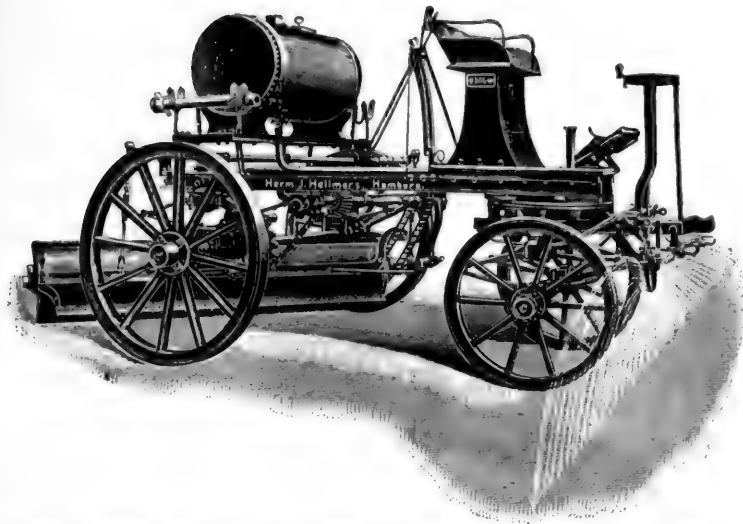

Type of Street Sprinkling and Sweeping Machines for two horses used in many German cities, including Munich, Dresden, and Leipzig. Tank capacity, 85 gallons, and must be filled about every half hour. Weight of machine about 2755 lbs. Cost \$315.50. The piassava broom costs \$5.50 and will sweep 900,000 sq. yds. before it is worn out. This machine sprinkles much, little or very little water, and sweeps a path 248 cu. yds. wide. The total expense of operating this machine, exclusive of allowance for first cost, brings the cost of sprinkling and sweeping to about \$2.40 per day against \$4.60 for hand labor. This is on the basis of 53,820 sq. yds. cleaned per day or night of eight effective working hours.

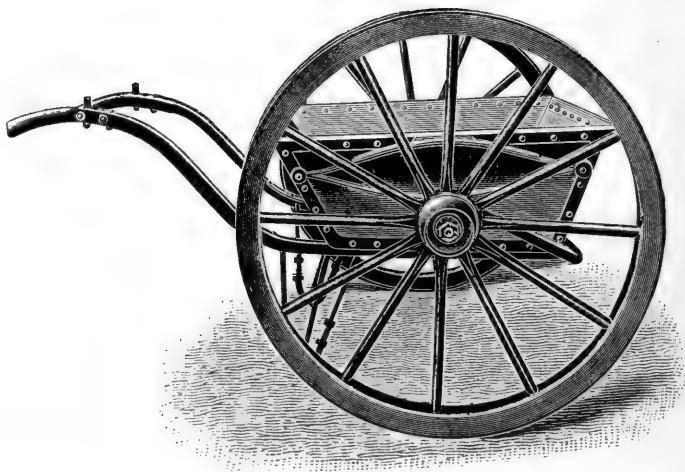

Hand Cart for Street Dirt collected by Orderlies in Germany. Capacity, 4.25 bu. to 14.19 bu. Wheel 3 ft. diameter.

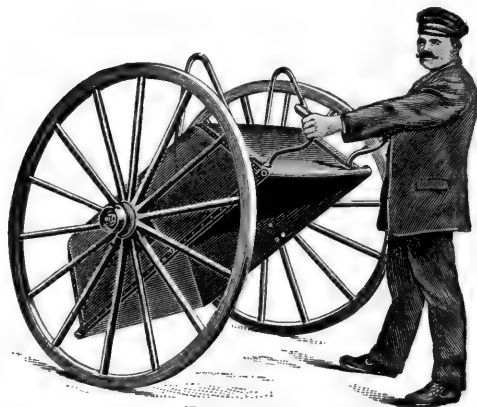

Metal Snow Cart used in many German cities, including Hamburg, Cologne, Munich, Stetten. Capacity .6 cu. yd. Weight 286 lbs. Cost \$22.80. It is estimated that to clean .65 cu. yd. of snow from 143.50 sq. yds. of pavement and carry it away by these carts costs \$.02.

COLOGNE

17,632 pounds could be burned in a cell in twenty-four hours, that is, 734 pounds in one hour (in Hamburg by way of trial 18,176 pounds of Cologne refuse of the average quality of that collected in 86 streets were burned in twenty-four hours), about 661 pounds of steam could be generated with a cell in one hour.

The cost of building a refuse-burning plant in Cologne has been estimated and it is believed that the question of utilizing the refuse will be solved in a short time.

CHAPTER XIII

AMSTERDAM

COMPARED with many other large cities of Europe, Amsterdam is a city of recent origin. It was founded in the fifteenth century, at which time a castle was located here and a dam, which gives the city its name, was constructed where the Amstel enters a small arm of the Zuiderzee. The site of the old dam is now the center of a semicircular city of 538,800 (1902) inhabitants.

Amsterdam has long been prominent for its commercial activity and for extensive and far-seeing projects intended to improve its opportunities for commerce. In the seventeenth century Amsterdam was the greatest mercantile city in the world, and it is to-day a place of great commercial importance.

From an engineering standpoint, the construction of the city is a subject of unusual interest. With the dam as a center, canals have been built in the form of numerous concentric circles. Intersecting these like radii are other canals which enable water communication to exist between all parts of the city.

The harbor occupies the position of a diameter for all the concentric canals, but, speaking accurately, it is shaped like a crescent whose points extend like open arms, one to the Zuiderzee and the other toward the

AMSTERDAM

North Sea. The canals cut the city into about one hundred islands. There are 300 bridges. Many of the canals are 50 yards in width and 3 to 4 feet deep.

Paved streets, often beautifully shaded by trees, run along both sides of the canals. Some of the older canals have purposely been filled to give more room for streets. The streets are paved with asphalt and stone-block pavements. The Kalverstraat, lined with cafés and shops, is one of the most crowded streets in the world. In the evenings it is so crowded with promenaders that it is practically impossible for vehicles to pass along it.

All the houses are built on piles; the number entering into the construction of some of the larger buildings numbering thousands.

Artificial waterways capable of accommodating the largest ships have been built to connect Amsterdam with the sea. The North Sea canal, about fifteen miles long, is the widest and deepest canal in the world, its cross-section exceeding that of the Suez Canal, and being exceeded in turn only by the proposed section of a part of the Panama Canal. In 1906, 2373 vessels, mostly steamers, passed inward through this waterway. The total number of vessels of all kinds which passed in both directions in 1906 was 25,904.

North Sea
Canal

The level of the water at Amsterdam is controlled by locks which open toward the Zuiderzee and North Sea. The arrangements are such that the authorities can flush out the water of the canals for sanitary purposes, a proceeding which is regularly followed at night. In the daytime the water is sluggish, although in most canals there is a gentle current flowing at practically

all times. The rise and fall of tide at Amsterdam is normally about 5 feet.

With the obstacles presented by the low lying situation of the city, the unstable condition of the soil and the network of canals, it is not strange that unusual difficulties should attend the collection and disposal of the city's wastes. Nearly every system known for handling human excrement has been employed here upon a scale sufficient to give it a practical trial.

At present the largest part of the city, including the oldest section at the center, discharges its sewage into the canals. There are about 4000 buildings in this quarter, however, where the excrement is collected in tubs which are emptied at night into carts very much as kitchen garbage is emptied in American cities.

The Liernur system of sewerage in which the carrying off of water is replaced by powerful suction applied at a central station, serves about 6400 buildings. Amsterdam has the largest installation of sewerage on this principal in existence. In addition to the above mentioned number of buildings served by the permanent Liernur system, there are about 6400 buildings which are connected with a part of the Liernur system which is considered temporary. The total number of inhabitants served by the Liernur sewerage works is 100,000.

There are 290 buildings supplied with excrement barrels that are removed periodically, but not as frequently as once each day.

Finally, 3000 buildings are supplied with Monier pits with overflows to the canals.

It is proposed to build a sewerage system on modern lines for part of the old city and to provide for the



Amsterdam—House Excrement and Refuse being made into Compost for Agricultural Use.



Amsterdam—Refuse Disposal Plant. Picking sheds to the right. Boats loaded with excrement receptacles from dwellings not connected with a sewerage system.



Amsterdam—Modern Type of Metal Dumping Wagon fitted with Crane for raising heavy receptacles of filth.



Amsterdam—Self-dumping Metal Wagon with Hood for Loading Excrement Odorlessly. An extensive nightly house-to house service is maintained.

future settlement of the city beyond the older districts.

The care of the sewerage system and the utilization of the wastes is carried on under the management of the street-cleaning department.

There is an extensive depot situated near the north-west limits of the city where refuse of all kinds is carried. The product of the Liernur system and excrement collected by other means is converted into sulphate of ammonia by means of a chemical process which has been perfected at this establishment. Other refuse from the houses, streets, and to some extent from the canals, is brought to this depot to be made, after a careful overhauling for the recovery of salable products, into compost.

Fertilizer
Works

The sulphate of ammonia, a white and inoffensive salt, has a ready sale at about \$50 per ton. This partly compensates for the cost of operating the Liernur system of sewerage. The system is not regarded as satisfactory; it is objectionable from many standpoints.

The refuse which is collected from houses is brought to the depot for overhauling in boats and carts. The products are taken away in boats and by railway.

House Refuse

The method of collecting refuse at the houses is picturesque and suggestive of customs which have in most great cities long been superseded by more modern customs. The refuse cart, a large, cumbersome affair, is accompanied by two men who empty the receptacles placed outside of the houses as the scavengers pass. On the approach of one of these carts it is the duty of one of the attendants to go ahead a little distance and operate a noisy watchman's rattle, ringing at the same time doorbells on each side of the street.

When a sufficient number of households have been aroused in this manner, the attendant returns to his companion and helps empty the receptacles of refuse in a systematic manner. The celerity and efficiency exhibited by these scavengers is surprising in view of the fact that their work is obviously carried on at a disadvantage.

The employment of household refuse for the making of compost is such a common procedure in Holland and has so many theoretical merits to recommend it for small cities that a few words about it may be of interest. It seems surprising that composting has not been more often practiced in America.

To compost refuse it is put into heaps about 20 feet long by 10 feet wide by 5 feet high. The heaps are well wet down when they are first made, the wetting being done in a careful manner and with material such as the contents of cesspools. After six months or so the compost heap is opened and dug over. It now has a dark, disintegrated appearance and is ready to be used as fertilizer. The change which has taken place in the refuse is due to bacterial activities. The action should first be carried on by anaerobic bacteria and later by bacteria which require a free access of air. A compost heap once made should be kept rather dry on the outside, but it is not necessary to shelter it from the weather.

Besides attending to the sewerage and removing and disposing of house refuse, the city cleaning department has charge of the sprinkling and sanding of streets to avoid slipperiness, the care of lavatories and public comfort stations and the removal of snow.

AMSTERDAM

The department owns its own apparatus and horses.

For collecting refuse, the city is divided into six sections and these are subdivided into 76 wagon districts. In addition, there are two districts served by boats. The laborers employed in this work number about 170.

Collection of
Refuse

In forty-one wagon districts, the refuse is carried to covered piers, of which there are five; from these points barges convey it to the depot for final disposition. The refuse from the remaining districts is hauled to the depot direct. In addition to this service, all vessels lying at docks and in the harbor are relieved of their ashes and refuse by means of a motor boat.

In the year 1906 there were 320,000 cubic yards of ashes, garbage, and other refuse conveyed to the depot at an expense of \$42,900.

The number of horses employed in the year mentioned was 144. The cost of keeping these horses is about 33 cents per animal per day, estimated on the basis of food and bedding consumed.

In the work of cleaning the canals and maintaining them at proper depth, 1398 boatloads of floating refuse and 5617 carcasses of animals were collected at a cost of \$2558 for labor. The work of dredging was done, in 1906, by contract at the rate of about 19 cents per cubic yard. The material dredged was deposited in a remote part of the harbor for the purpose of making land. This work was commenced in the middle of April and ended toward the close of October. Three dredging-machines were employed. The total cost of dredging from the various canals was \$14,341, the aggregate quantity of

Cleaning the
Canals

MODERN METHODS OF STREET CLEANING

material removed being 76,400 cubic yards. There was a considerable amount of private dredging done in addition to that carried on by the city.

There were twenty floating or partly sunken vessels or unclaimed boats cared for or confiscated by the cleaning department. Some of these were removed by the owners, others were raised by the city and afterward reclaimed by the owners after paying the expenses incurred by the city.

As showing the difficulties encountered in preventing the accumulation of refuse in the waterways, it is interesting to note that the city removed, in addition to the refuse, five hand-carts, a considerable number of poles, logs, and miscellaneous large objects, and four granite gravestones.

The street pavements which required sweeping were, at the end of the year 1906, 4,229,000 square yards in area. Of this, 4,136,000 square yards were
Street Clean-
ing stone or brick pavement and 93,000 asphalt.

The stone and brick pavements are cleaned by hand sweeping, by sweeping done by means of revolving brooms propelled by horses, and by washing with hose with water from the canals. The asphalt pavements are cleaned by hand with hose, brooms, and rubber squeegees, and by a combination water-cart and revolving squeegee such as is employed in some other continental cities. About 45,000 cubic yards of water were used in washing the streets in 1906.

The streets were sprinkled on 161 days, about 230,000 cubic yards being used in this work. Sprinkling-carts
Sprinkling are employed chiefly in the central part of the city and hose in the outlying districts. A street-sprinkling apparatus operated by electricity has



Amsterdam—Showing Sewer Outlets into the Canals of Water-streets near the center of the city.



Amsterdam—Covered Metal Railway Cars for transporting Offensive Refuse to the Country without causing offense.



Where Street Cleaning is Unknown. Highway between Vollandam and Edam, Holland.

AMSTERDAM

been employed to sprinkle the streets from the tracks of the electric car lines.

There were several falls of snow which required the employment of extra men to clear the streets in 1906. The extra force put to work on these occasions ranged from about 340 to 1200. Snow is removed by the use of salt and by hauling it away. Snow ploughs have been used to good advantage. The cost of the work made necessary by snow, including the sanding of the steep approaches to bridges, amounted to \$8266 in 1906.

Snow

The total number of men regularly employed is about 600. This force is increased from time to time to about double the number stated in accordance with a kind of elastic arrangement. Among the different classes of employees at work in 1906 there were 254 laborers at the depot for the handling of refuse; 133 drivers of carts and wagons; 115 pump men and assistants; 112 sweepers; 78 boys to assist in handling the garbage and refuse; 75 sewer men and 74 officials, foremen and inspectors, in a total of 1002.

Force

As to sickness, there were in 1906, the only year for which we have statistics, 4675 sick days distributed among 506 regular men and 1855 sick days among 305 temporary men. Among the regular men there were 112 accidents, incapacitating their victims an aggregate of 1271 days.

The total expenditures incident to the operation of the depot for the handling and final disposal of refuse including the excrement collected from the houses by the Liernur system, and otherwise, were \$82,232. This division of the work is apparently self-supporting, for the receipts were \$82,081. The

Cost

MODERN METHODS OF STREET CLEANING

recovery of rags from the refuse showed a clear profit of \$33,821. The refuse was removed from the depot in 2494 vessels, inclusive of 300 boats used partly for this work by the city. There were 714 carloads of manure and 164 carloads consisting of rags, cast-off shoes, bones, tin cans, and similar rejecta shipped by rail. Valueless refuse to the extent of 3510 boatloads were dumped on low grounds situated at a distance.

CHAPTER XIV

NEW YORK

NEW YORK affords a good example of a city of the largest class wherein the highest standards of sanitation are demanded, and where these standards are capable of being attained without undue cost. The population is great; it is, in places highly concentrated, and in race, habit, and social condition exceedingly diverse. Practically all the conditions necessary to maintain life in a wholesome way must be secured through a careful observance of sanitary rules and principles. This relates not only to the food, clothing, and habitations of the people, but, in a peculiar degree, to the care of their wastes. Upon the prompt and adequate disposal of these wastes largely depends the security of the city against disease.

Fortunately the area covered by the city is divided and subdivided by water courses—for the most part, broad and deep arms of the sea. The city has over 400 miles of water front. If a circle of twenty miles radius be drawn on a map so as just to include the extreme northern and southern limits of the city, it will be found to contain nearly half as much water as land. Throughout the history of New York the tidal waters have played an important part in the disposal of the city's wastes. The sewage of the entire population has always been and is now discharged into the rivers and other tidal waters in New York City and vicinity without purification. Until very recent years

the refuse from the streets and houses was emptied into the harbor also. These customs have, with the growth of population and the adoption of higher æsthetic standards, come to be regarded as insanitary. There is now* a municipal commission, of which the author has the honor to be chairman, charged with the duty of making a careful investigation of the sanitary condition of the waters of New York and vicinity and formulating a general plan or policy of conservancy. So far as the disposition of the solid refuse collected from the streets and houses is concerned, the tidal waters of New York and vicinity are important only as they afford cheap and convenient means of transportation by boats. It is with these wastes alone that this chapter has to deal.

The solid refuse which is produced in the city of New York is disposed of chiefly by an executive division of the city government called the Street Cleaning Department. This department exercises jurisdiction over three of the five boroughs into which the city is divided. These three boroughs contain about four-fifths of the total population, or 3,956,905 people, and about one-half of the total area, or 140 square miles. The two boroughs of New York which are not under the care of the Street Cleaning Department are cleansed by separate bureaus under the borough presidents. The borough presidents are elected by the people and in turn appoint superintendents of the bureaus of street cleaning. The methods of work are practically the same as those followed by the Department of Street Cleaning and will not be separately referred to in this paper. Table I gives the areas, population, and lengths and areas of streets in the five boroughs of New York:

* 1908.

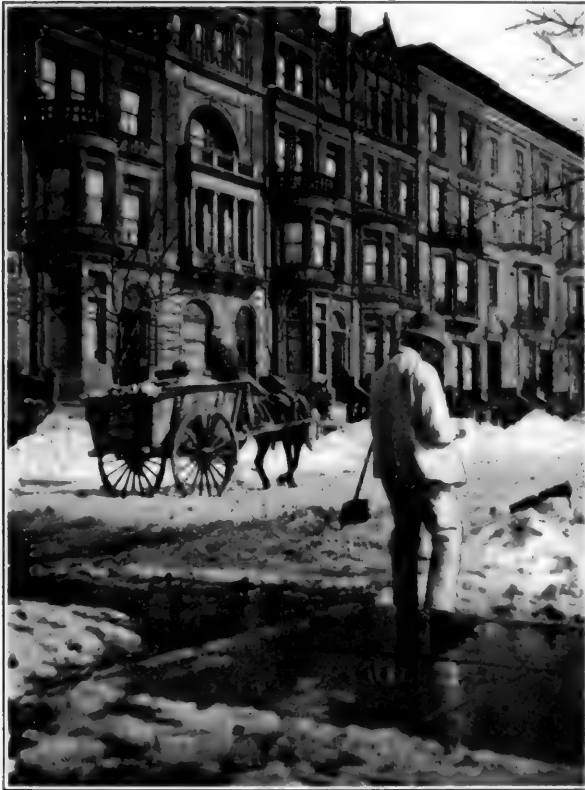

Street Sweeper clearing the Gutters and Cross-walks after a Snow Storm
in New York City.

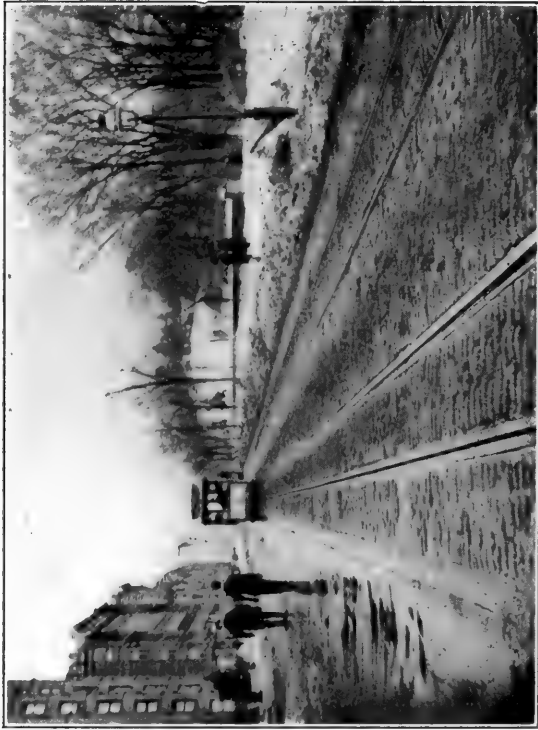

In New York City the traction companies clean their tracks of snow by sweeping it to the sides of the streets.

NEW YORK

TABLE I.—STATISTICS OF NEW YORK CITY AND ITS FIVE BOROUGHS IN 1906

	Area in Square Miles.	Population 1906.	Paved Streets.	
			Length in Miles.	Area in Square Yards.
Manhattan	22.00	2,165,015	443.45	9,411,120
The Bronx	40.50	351,487	201.59	2,955,052
Brooklyn	77.50	1,440,403	647.08	11,105,667
Queens	130.00	222,539	365.60	4,237,153
Richmond	57.25	78,943	200.10	2,425,393
	327.25	4,258,387	1,847.84	30,134,385

The organization of the Street Cleaning Department as a separate branch of administration in New York City dates from the year 1881, up to which time the collection and disposal of street and house refuse was carried on under the direction of the Department of Police. The new organization was the outcome of much agitation on the part of the public against the order of affairs which existed at that time. Physicians and civic reform associations took an active part in this crusade. It is interesting to note that, with the exception of a few brief intervals, the department has ever since its creation been a source of dissatisfaction to the public for the work has not been done with the thoroughness and economy which the people consider desirable. The result has been that exhaustive and formal investigations have been made into the affairs of the department on a number of occasions and the official head of the department has often been changed.

Origin of the Street Cleaning Department

The first investigation was in 1891 when a committee of eminent citizens made a study of the subject of

MODERN METHODS OF STREET CLEANING

street cleaning at the instance of Mayor Hugh A. Grant. In 1891 a second investigation was made by a committee appointed by the state legislature. The latest inquiry into the affairs of the Street Cleaning Department was completed on December 31, 1907, by a commission of eminent engineers* appointed by the present Mayor, George B. McClellan. It was partly to assist this commission in studying the problem of cleaning the city and disposing of the collected wastes that the author visited a large number of European cities and had the pleasure of meeting many foreign street cleaning officials in the summer of 1907.

From the mass of information collected by various investigating bodies, many of the general principles upon which the Street Cleaning Department of New York should be conducted appear to be fairly well established. The difficulty is to put these principles into force. The magnitude of the problem and the peculiar political conditions under which municipal work is performed in American cities are serious obstacles in the way of conducting the department in a strictly businesslike manner. The refuse collected in the whole city amounted in 1906 to 8,359,648 cubic yards or 3,159,182 tons. If this refuse was piled in Madison Square Park it would rise to the height of the Flatiron Building.

It was clearly stated in 1891 by Mayor Grant's investigating commission that the problem of street cleaning in New York was largely a problem of organization and executive management. "It requires," they said, "the

* The members of this commission were Messrs. H. de B. Parsons, Rudolph Hering, and Samuel Whinery, all members of the American Society of Civil Engineers.

same kind of ability and training as is found in and developed by transportation companies and other great corporations employing large bodies of men. Its technical details are comparatively simple and require no extended knowledge of engineering or other science. There is doubtless room for improvement in the mechanical appliances now employed and an alert commissioner will watch the progress of invention in such appliances, experiment with them and adopt such as are useful. But in the main it is a question of the judicious employment of a large body of laborers." Just what was meant by the term "judicious" the commission did not explain. Persons familiar with municipal conditions in America may form their own opinion. All will agree that the practical details of running a city department and a commercial corporation are, unfortunately, very different.

The Problem
One of Organ-
ization and
Administra-
tion

Up to the present time there has been but one head of the Department of Street Cleaning who has had previous sanitary training or experience in directing a large force of men. This was Colonel George E. Waring, who was appointed in 1895 and served for three years. The organization and technical methods in use to-day are substantially those outlined by investigating commissions or introduced in practical form by Waring.

The official at the head of the Street Cleaning Department is called a Commissioner and is appointed by the mayor for a term which is generally understood to be the same as the mayor's term of office. The commissioner in turn appoints three deputies, a general superintendent, an assistant

Present Or-
ganization

MODERN METHODS OF STREET CLEANING

superintendent, a superintendent of final disposition, an assistant superintendent of final disposition, a master mechanic, forty clerks, and the laboring force. The commissioner receives a salary of \$7500 per year.

There is one deputy commissioner for each of the three city boroughs which are under the jurisdiction of this department. Under the deputies are district superintendents and beneath these foremen. For purposes of administration the city is divided into 22 street-cleaning districts, each of which has its own headquarters. Theoretically, the district superintendent is the directing head of the district, but practically the foremen direct the work and the superintendent acts as an inspector. There are sweepers, cart drivers, stablemen, hostlers, mechanics, clerks, and other employees. The total laboring force in the department on July 31, 1907, consisted of 5129 men. The total cost of this department in 1907 was \$9,381,592.

The members of the force, except the commissioner and his deputies, are under the protection of civil service laws; that is, they are appointed and promoted only after competitive examinations and cannot be discharged except on proved charges. The working force is uniformed. The street sweepers wear helmets and white duck suits, which they are required to keep clean. The men engaged upon the carts and in other operations concerned in the removal of refuse wear brown uniforms. The foremen and superintendents wear gray.

The work of the Street Cleaning Department includes the collection, removal, and final disposition of refuse from the pavements of the streets, kitchen wastes, ashes and rubbish from private dwellings and snow from the principal thorough-fares.

Duties and
Difficulties

The carriageways alone are under the care of the Street Cleaning Department. The sidewalks are cleaned by the owners of the abutting property. The department has authority to make rules and regulations to compel householders to prepare their wastes in a convenient way for removal by the department, and when these regulations are approved by the Board of Aldermen they become law, superseding, or taking precedence of, any other ordinances that may be in conflict therewith. It has always been impossible for the Department of Street Cleaning to get the police and police justices to coöperate satisfactorily in enforcing the laws which relate to the cleanliness of the city. Coöperation, so necessary everywhere in carrying on municipal work in an efficient and economical manner, is conspicuously absent in the cleaning of New York.

The streets are kept in repair by a department of the city government which has no relation to the Street Cleaning Department. The departments of health and police are also quite separate. The streets are sprinkled by contractors who enter into agreements for this work with owners of property abutting upon the streets. Dead animals are removed by contract let by the Department of Health. Trade wastes are not collected by the Street Cleaning Department nor are the ashes or kitchen wastes from large restaurants, hotels, and shops. Private scavengers, operating under licenses issued by the health department, collect large quantities of refuse. They carry some of it out of the city to be fed to hogs and other animals and dump some of it into barges at the water front. Little is known about this private work. Large, therefore, as is the force of the Street Cleaning Department, and extensive as are its operations, it is

obvious that the work of scavenging New York is much more extensive and costly than the official figures represent.

The streets are swept, for the most part, by hand. **Methods of Work** The charter of the city specifically states that hand work shall be the principal reliance, although machines may be used to supplement it.

The street sweepings collected by the department in 1906 amounted to 1,183,998 cubic yards and weighed 567,971 tons of 2000 pounds each. In the most crowded borough of New York (Manhattan), it is estimated that the sweepings average 81 cubic yards per thousand square yards of street pavement through the year or 325 cubic yards per thousand inhabitants or 8760 cubic yards per 1000 horses. These ratios are mathematical and probably do not represent conditions which prevail either in large parts of the city or at all seasons. Nothing is more evident to practical street cleaning men than the variations which occur in the quantity of refuse produced in different parts of a city and at different seasons.

In view of the extent to which machines are employed in cleaning the streets of European cities, it is interesting to observe that the recent commission of investigation in New York concluded that hand sweeping was cheaper than machine sweeping. Estimates were made to show the cost of each. In these calculations it was assumed that the street was paved with sheet asphalt, well constructed and in good repair, that the travel and other conditions were about the average for New York, and that the work was done by the municipal labor and plant. A machine sweeper was assumed to sweep once about 70,000 square yards of street in one day of eight

hours. The cost of this work, including wages, repairs, depreciation, interest on the investment and incidentals, was \$0.317 per thousand square yards. A hand sweeper was assumed to be capable of cleaning satisfactorily 8000 square yards of pavement per day at a cost, including wages, interest, and depreciation of his tools, of \$0.281 per thousand square yards.

The cost of flushing the streets with water, based on a calculation similar to the foregoing, but with a charge of \$90 per million gallons for the water was \$0.251 per thousand square yards. It was assumed in this last calculation that three men would be required in each gang, one to handle the nozzle and the other two to assist in manipulating the hose and to sweep out spots where the dirt adhered to the street surface with unusual tenacity. In this estimate it was assumed that the area washed would average 5000 square yards per hour.

The wages paid in New York are materially higher and the cost of maintaining horses considerably greater than contractors pay in other cities. The street sweepers received in 1906, \$2.19 per day.

At the present time the hand sweeping is done in a very simple, not to say primitive, manner. The implements employed are a push broom, a push scraper, a short-handled broom, a short-handled shovel, and a can carrier. The scraper is much used on asphalt streets and is a peculiarly serviceable tool. In shape it is like a very wide, flat shovel with a long handle. Its dimensions are usually 36 inches along the scraping edge, 18 inches long, and 3 inches deep. The handle is about 8 feet long. The scraper is pushed ahead of the workman who walks rapidly after it, thus lifting the refuse from

MODERN METHODS OF STREET CLEANING

the pavement and carrying it to the curb. The can carrier is a light, low, two-wheeled, carriage framework in which metal receptacles for refuse, about the size of a barrel, are placed. The sweepers' various cleaning implements are carried in this way. The sweeper works from 7 A.M. to 4 P.M. and is expected to keep his route clean during this time. On Dec. 31, 1907 there were 2930 sweepers in the three boroughs of Manhattan, Brooklyn, and the Bronx.

The special commission which investigated the conditions of street cleaning in New York in 1907 found the quantity of dirt, mostly dust, which remained on the surface of the streets after an ordinary sweeping, averaged .4 cubic foot per 1000 square yards of pavement. The quantity which had been removed was 4.9 cubic feet. These figures relate to asphalt in good condition. The work done by machines and on other pavements was less satisfactory. The mileage and area of different kinds of pavements in the whole city of New York are given in the table on page 171.:

Each laborer is assigned to a certain area of street varying in length from 400 feet to one mile. This he endeavors to keep clean by scraping and by sweeping the dirt toward the curb and then gathering these collections into piles. The dirt is either immediately placed in cans or bags on wheeled carriers or later the sweepings are taken away in carts to the water-front and tipped into barges. Most of the sweeping is done in the daytime and is not preceded by sprinkling.

In a few of the most densely crowded sections of the city the streets are cleansed with water from a hose and by a water-cart known as a flushing machine. The work is done during the daylight hours. It is said that

NEW YORK

TABLE II.—MILEAGE AND AREA OF DIFFERENT KINDS OF PAVEMENT IN NEW YORK CITY IN 1907

Kind of Pavement.	Length in Miles.	Area in Square Yards.
Granite block	299.55	6,156,232
Specification trap block	25.26	443,508
Belgian trap block	64.26	1,236,361
Sheet asphalt	590.25	11,118,265
Block asphalt	74.15	1,473,085
Cobble	51.06	888,585
Wood block	14.45	284,401
Macadam	685.55	7,920,997
Brick	19.74	331,211
Iron slag block	0.51	7,774
Medina block	5.60	89,589
Gravel	17.46	184,377
Total	1847.84	30,134,385

about 75 miles of streets are washed each day in summer. The water is applied in large quantity upon the direct surface of the pavement; the dirt is not previously moistened and lubricated.

Most of the refuse which is collected from the streets is taken to city barges at the water-front and ultimately conveyed to low-lying land usually within the city limits.

Householders are required to separate their refuse into three receptacles. One receptacle contains garbage, kitchen waste or swill, as it is variously termed in America. Another contains ashes. A third ^{House Refuse} receptacle contains what is locally called "rubbish:" bits of paper, cloth, bottles, metals, and similar refuse. This separation causes no great inconvenience to the housekeeper and greatly facilitates the final disposition of the wastes. Yet in some parts of the city

there is difficulty in having the refuse separated at the houses.

The kitchen waste is collected at varying intervals, depending upon the season of year and the concentration of population in the different parts of the city, the intervals ranging from every day to twice a week. This kitchen material weighs about 1100 pounds per cubic yard. It differs materially from English refuse, containing more moisture, less inflammable matter, and, at some seasons, at least, more vegetable refuse. Analyses of New York garbage have been made, but nothing short of exhaustive examinations and most carefully digested data can give a correct idea of its composition. It must be remembered that garbage is a mixture, every ingredient of which is likely to vary in composition and amount. The garbage taken to Barren Island is believed to contain about 70 per cent water, $24\frac{1}{2}$ per cent vegetable fiber, 3 per cent grease, and $2\frac{1}{2}$ per cent rubbish. In 1896 Street Cleaning Commissioner Waring obtained as an average, on analyzing 300 tons of summer refuse from four different cities, 71 per cent water, 20 per cent tankage, 7 per cent rubbish, and 2 per cent grease. The quantity of kitchen refuse collected by the department in the whole city of New York in 1906 was 715,625 cubic yards or 392,357 tons.

Kitchen refuse is collected by the Department of Street Cleaning in open metal carts and carried to the water-front where it is tipped into barges or to depots from which it is removed by trolley cars. Most of the barges belong to a contracting company whose business it is to transport and dispose of the refuse by the process termed reduction. The refuse is carried

NEW YORK

through the harbor on the barges to a plant at Barren Island at Rockaway Inlet in lower New York Bay. Here the refuse is put into metal retorts. Water is added, the retorts are closed, steam is turned on, and the garbage is cooked until the contained grease becomes fluid. The heating is then stopped and the liquid run off. The grease is separated, chilled, and sold by the utilization company. The residue from the retorts is pressed and utilized as a basis for agricultural fertilizers. This process is employed in a number of large cities in America. The company which does the work receives a substantial bonus from the city. The New York Sanitary Utilization Company has contracts for the three boroughs of Manhattan, Brooklyn, and the Bronx.

For many years the refuse of New York was not separated but collected in a mixed condition and carried out to the ocean for disposition. During a temporary suspension of the Barren Island reduction plant, due to its destruction by fire in the summer of 1906, a part of the kitchen refuse of New York was carried out to sea, as had been customary in some other years. In all, about 125,000 cart loads of $1\frac{1}{2}$ cubic yards each were disposed of in this manner. The barges discharged their cargoes at a point midway between the New Jersey and New York shores and about fifteen miles from land. About 1100 cart loads a day was the average. Owing to complaints from the numerous summer resorts on the shores of New York and New Jersey, a careful investigation into the fate of the garbage was made by the Metropolitan Sewerage Commission at the request of the mayor of New York. The refuse was found floating in the water over an area of many square miles; it was washed upon the beaches

for fifty miles along the New York shore and for seventy-five miles along the New Jersey shore. It was recommended, if sea dumping was to continue, that the refuse be carried to sea in ocean-going vessels and cast overboard at least one hundred miles away from the nearest shore.

Ashes are collected from the houses at varying intervals, probably on an average of once a week. The ashes weigh about 1000 pounds per cubic yard. The ashes are almost exclusively the residue of coal. New York is fortunate in being supplied largely with anthracite. In 1906 the total quantity of ashes collected by the Department of Street Cleaning in the whole city of New York amounted to 3,755,047 cubic yards. The ashes were, for the most part, hauled to the waterfront, tipped into barges, and taken away to fill low-lying land. The same carts are used for collecting ashes and garbage, but both are never collected at the same time.

The standard cart is a heavy metal vehicle of one and one-half cubic yards capacity, set high between two large wheels. It is provided with a canvas cover.

Plant Like most refuse carts, it is by no means well suited to its uses. It is too high, too heavy, and too small. It allows its contents to be blown out by winds and joggled out by the rough pavements. Its chief merit is durability.

One man goes with each cart in the capacity of driver. It is his business to take the receptacle in which the refuse is placed from the sidewalk or area in front of the house and empty it into the cart. Each cart has a specific route which averages about one mile in length. A few trips are first made for the col-

NEW YORK

lection of ashes after which the cart collects garbage until all the garbage on the route has been taken up and carried away. The collection of ashes along the route is then resumed and continued until the day's work is done. The receptacles used by the householders are supposed to be of metal and about the size and shape of barrels, but this is not rigorously insisted upon. Each driver is required to work from 6:30 A.M. to 4 P.M., at which time his route should be cleaned. There are about 1300 drivers. Each cart horse travels about twenty miles per day.

The papers and associated light refuse are collected in special carts of large capacity. The weight of the material handled averages about 143 pounds per cubic yard. The rubbish is collected when the householders notify the department by a signal card placed in the windows that there is material to be taken away.

The paper and associated refuse are taken to central depots or to piers along the water-front where they are sorted, bagged, and the useful matter sold by contractors. The city receives a small sum of money from a contractor in return for this privilege of picking over the refuse. This contractor sublets the picking privilege to other contractors. This work is done in a dirty, untidy, and insanitary manner. All the pier dumps are of primitive design and, with one exception, are uncovered. There are seventeen dumping places located at as many piers in the three boroughs which are under the charge of the Street Cleaning Department. The greatest distance from one dumping place to another is about four and one-half miles. Experiments were made nearly fifteen years ago by the Department of Street Cleaning under Commissioner

Utilization
of Useful
Articles

MODERN METHODS OF STREET CLEANING

Waring which showed that the refuse could be overhauled and the marketable ingredients separated and sold advantageously by the city, but the results of these experiments have not led to any important changes in the plant or methods of disposition followed by the city.

In the borough of Brooklyn a private corporation has a contract for the final disposition of ashes, street sweepings, and rubbish. This company has thirteen receiving stations located at various points in the borough. The carts of the Street Cleaning Department deliver their loads at these receiving depots, and, after the marketable portions have been sorted out, the refuse is conveyed in iron receptacles on electric trolley cars to low-lying land where the material is tipped. Refuse destructors have been constructed at two of these stations.

That portion of the refuse which consists of paper and other inflammable matter has been experimented with by the city to determine the conditions under which it can be burned in destructors. These experiments indicate that about 2.2 pounds of water can be evaporated at 212° F. per pound of rubbish. The city has several small destructors, but this system has not as yet been extensively employed for disposing of any part of the city's wastes. In fact, the care which these plants receive discourages the belief that first class destructor works would be successful.

Before 1896 snow was removed by the department force aided by laborers temporarily employed for the purpose. Snow now is removed from the streets by contracts drawn up and let, after public bidding, by the Street Cleaning Department. The regular force is quite incapable of dealing with this

Snow

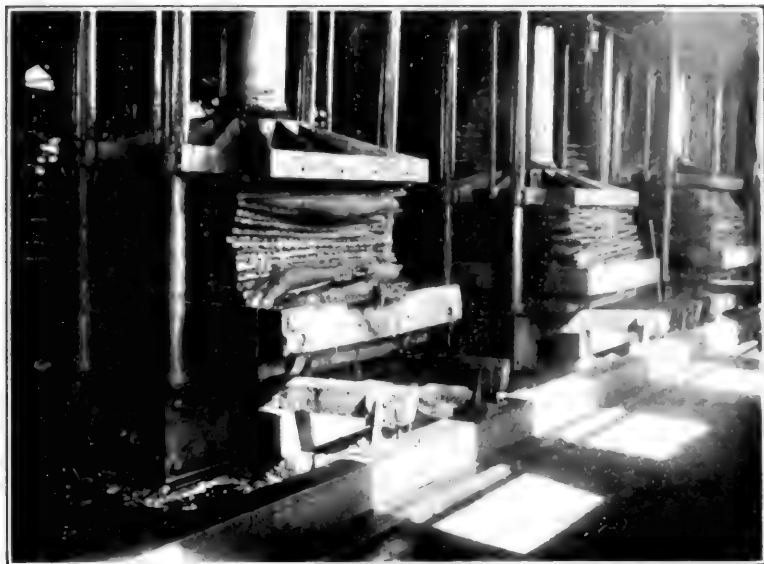

Presses: Barren Island Garbage Reduction Plant.

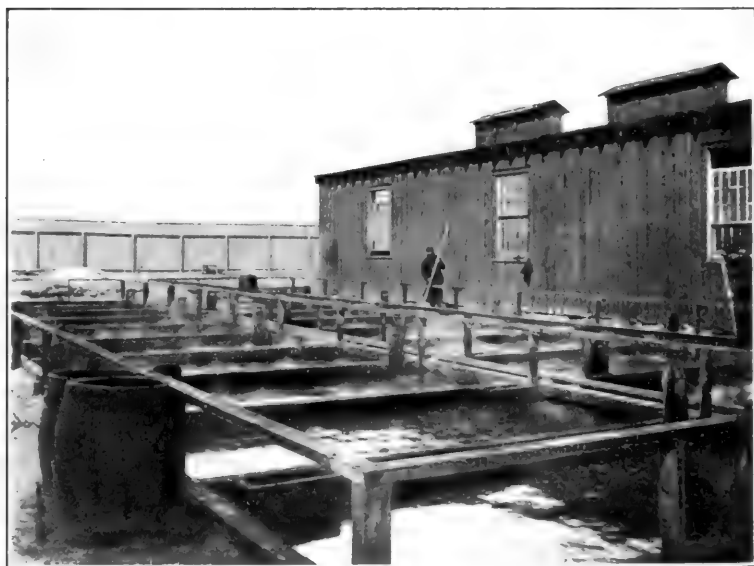

Grease Basins: Barren Island Reduction Plant.



Horse-propelled Street Sweeper.



Street Sweeper with Hand Brush and Push Cart.



Brooklyn Rapid Transit Ash Dumping Station.

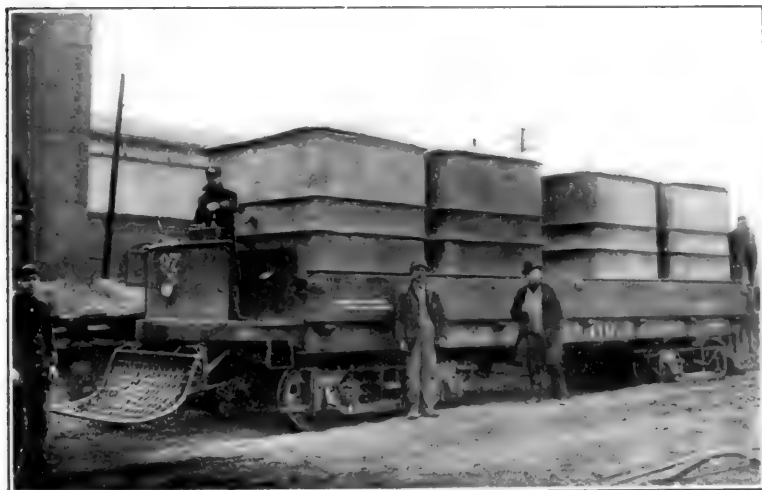

Brooklyn Rapid Transit Ash Car.



Street Sweeper with Push Scraper.



Paper and Rubbish Cart.

problem and at the same time keeping up with their regular work. The contracts are entered into each year just before winter sets in. The contractors offer to collect the snow from the pavements and carry it off for so much a cubic yard. The price generally ranges from about 15 cents to 25 cents a cubic yard. The sum spent for this work in 1907 was \$2,470,950.47. The quantity removed was 13,905,181.6 cubic yards.

When snow begins to fall the sweepers of the department leave their ordinary work and clear the crosswalks, remove snow from about the fire hydrants, and free the gutters so that in event of thaw the water from the melting snow can run off into the sewers. Some snow is removed by the department in the carts which at other times are used for garbage and ashes. It not uncommonly happens that the temperature immediately after a snow-storm is such that the snow melts during the day and freezes at night, so that if care is not taken to keep the drainage of the streets clear, ice may accumulate.

The householders clear the snow from the sidewalks to the curb line and often clean out the gutters. By the term gutter is meant the carriageway immediately adjacent to the curb. The snow from the steps, areas, and sidewalks is thrown into the carriageways. On residence streets, it is not uncommon for the snow to be piled up to a height of three or more feet. The first heavy snow-falls generally occur in December and may be expected any time until March.

The contracts entered into by the city for the removal of snow usually specify that work shall begin when two and one-half inches of snow have fallen upon the pavements, the depth being determined by a special

officer of the Street Cleaning Department. When the signal is given by this officer, the contractor puts his men upon the streets and works where the department directs. The force of labor employed often numbers many thousand and is recruited from whatever source may be available at the moment. The horses and carts are obtained by the contractor wherever he is able to get them. They are of every sort, kind, and description.

The workmen shovel the snow into piles and then load it into the carts. The carts carry the snow to the harbor and empty it into the water from the bulkheads. The contractor is paid according to the quantity of snow removed.

Two systems have been devised for estimating the quantities of snow. By one of these systems the quantity of snow removed has been computed by multiplying the area cleaned by the depth of the snowfall. The chief advantage in this plan of estimation is that it saves a large amount of supervision which the Street Cleaning Department must exercise over the accounts. It was devised to prevent fraud and to economize in the number of city inspectors required. Its defects include the possibility of great shrinkage due to rain and sun. This system was put in use after the winter of 1902-03. The other system of reckoning is by actual count of the carts and an estimation of the capacity of each. This plan has certain obvious advantages, but, owing to the very large amount of attention required by the city to prevent errors, the regular work of collecting refuse from the houses has to be abandoned at times in order to provide enough inspectors.

Up to the present time no satisfactory method has

been devised for cleaning the snow from the streets or paying a just price for removing it. Snow-melting machines have been tried without success. Salt is sprinkled on some of the streets by the street railway companies, but it is objected to because of its chilling effect on the feet. The snow has been shoveled into the sewers to some extent, but this is not approved of by the authorities in charge of the sewers. Snow plows are used only by the street railway companies. The street railways use an underground electric trolley system requiring a slotted rail between each pair of tracks. These roads are very rarely stopped by the snow.

The cost of dealing with the snow is large. A single snow-storm may cost the city through the Street Cleaning Department \$500,000. On the other hand, a winter like that of 1907-08 may occur with practically no snow except such as favorable weather conditions remove. Under these circumstances, contractors are unable to make satisfactory arrangements for labor and apparatus.

After what has been said, it will be understood that accurate records as to the quantity of snow removed from the streets of New York during a winter do not exist. It has been estimated that the quantity removed in the two boroughs of Manhattan and the Bronx in the winter of 1906-07 was 16,101,000 cubic yards. Of this amount about 10,000,000 cubic yards were removed by the snow contractor, 5,000,000 by the Street Cleaning Department with its own force and extra carts, and the remainder by street railway companies.

The Street Cleaning Department owns its horses and

MODERN METHODS OF STREET CLEANING

stables them in buildings which the city owns or rents. The number of horses used by the city in cleaning the streets in 1907 was 2064. The average cost of keeping these horses was \$490 per horse per year. This is somewhat in excess of the cost to private corporations of keeping horses in New York City. Self-propelled vehicles have not so far been employed.

Refuse other than garbage is transported by water by means of barges or scows. These scows are of three principal kinds. There is a flat scow which is unloaded by hand when used for dumping refuse at sea and by a mechanical orange-peel bucket when used for filling in low-lying land. A mechanical dumping scow, known as the "Barney," consists of two sections of a boat so built and placed as to make practically one craft. The load is carried between the two sections. When the load is to be discharged the two sections are separated by means of a mechanical arrangement and the contents fall out. The Barney dumper is used only for transporting refuse to sea. The third type of scow is a self-dumping, self-propelling catamaran called the "Delehanty." The refuse is carried in pockets suspended between the two hulls. The city owns 42 deck scows and 3 Delehanty catamarans.

The principal plant and apparatus owned by the Street Cleaning Department include, beside the stables, dumps, and scows, 1120 garbage and ash carts, 254 paper carts, 87 water carts, 63 sweeping machines, and 2064 horses.

The following table will give an idea of the money spent each year by the Street Cleaning Department for various purposes:

Cost

NEW YORK

TABLE III.—EXPENDITURES FOR MANHATTAN, THE BRONX,
AND BROOKLYN FOR THE YEAR 1907

	Appropriation.	Expended.	Unexpended Balance.	Deficit.
General Administration	\$36,974 85	\$36,974 85
Administration—				
Salaries of Clerical Force	85,002 52	85,002 52
Salaries of Uniformed Force	288,608 12	288,608 12
Sweeping—Salaries and Wages	2,186,378 08	2,186,378 08
Repairs and Supplies	93,998 16	93,998 16
Forage for and Shoeing Horses	88,502 71	88,502 71
Carting—				
Salaries and Wages	1,668,083 48	1,668,083 46
Repairs and Supplies	95,280 79	95,280 79
Forage for and Shoeing Horses	303,428 67	303,428 67
Final Disposition of Material, Including Cremation or Utilization—Salaries and Wages	110,682 17	110,682 17
Cost of Final Disposition, Contracts, Towing, Hire of Scows, Repairs and Supplies	1,150,701 85	1,150,701 85
Wages, Supplies, Rents, and Contingencies—				
Wages	47,339 10	47,339 10
Rentals	125,869 39	125,869 39
Repairs and Supplies to Stables and Section Stations	29,547 14	29,547 14
Office Supplies, Contingencies, and Telephones	19,453 03	19,453 03
Total, Working Accounts	\$6,329,850 06	\$6,329,850 06
Removal of Snow and Ice	10,314 94	10,314 94
New Stock—Plant	14,469 19	14,469 19
	\$6,354,634 19	\$6,354,634 19
New Stock or Plant—Boroughs of Manhattan and The Bronx	129,646 68	175,682 61	\$46,035 93
New Stock or Plant—Borough of Brooklyn	64,950 08	74,001 58	9,051 50
Revenue Bond Fund for the Department of Street Cleaning, Removal of Snow and Ice—Boroughs of Manhattan and The Bronx	1,800,117 90	1,799,831 92	\$285 98
Revenue Bond Fund for the Department of Street Cleaning, Removal of Snow and Ice—Borough of Brooklyn	660,842 47	660,812 61	29 86
Acquisition of Property for Stable, northwest corner of Eightieth street and Avenue B, Manhattan	71,020 69	70,236 41	784 28
Acquisition of Site for and Construction of Stable—Borough of Brooklyn	63,293 72	109,355 75	46,062 03
For Purchase of Three or More Automobiles—Manhattan, The Bronx, and Brooklyn	11,635 84	11,880 00	244 16
Revenue Bond Fund for the Department of Street Cleaning, Forage for and Shoeing Horses—Deficiency in Appropriation for 1907	102,000 00	125,157 56	23,157 56
Total	\$9,258,141 57	\$9,381,592 63	\$1,100 12	\$124 551 18

MODERN METHODS OF STREET CLEANING

The expenditures by the city for street cleaning in the Borough of Queens for 1906 was \$208,762.05 and for the Borough of Richmond \$168,567.97. Adding together the expenditures of the city government through its Department of Street Cleaning or separate Bureaus of Street Cleaning, we obtain the total of \$9,758,922.65.

INDEX

	PAGE
Accidents to laborers, Westminster	83
Administrative county of London	62
Advantages of centralization of work	43
motors for removal of refuse	81
Advisory board of engineers, London	61
Age, Employees, London	72
Street cleaning force, Westminster	83
Aim of sanitation	15
America, Disposal of house refuse	32
Amsterdam	152
Disposal of house refuse	155
Disposal of sewage	154
Removal of snow	159
Antwerp, Machine sprinkler	48
Arrangement of refuse-burning works, Hamburg	129
Artificial waterways, Holland	153
Ashes and clinkers, Hamburg incinerator	132
Ashes, Collection, New York	174
Disposition of, New York	176
Meaning of term	35
Utilization of	35
Asphalt pavement, Cleaning	39
Hamburg	123
Washing, Berlin	115
Authority over street cleaning, Manchester	85
Westminster	73
Automatic flushing machines	48
Automobile sweepers and sprinklers	100
Bank of England as center of London	63
Barges for removal of refuse	33
Barging refuse, Cost, Westminster	75
Barney dumper, New York	180

INDEX

	PAGE
Barren Island	173
reduction plant, New York	173
Bellegrand sewerage systems, Paris	98
Berlin, Administrative division of city	112
Character of streets	111
Cost of street cleaning	118
Council	109
Length and area of streets	113
Motor sprinkler	51
Nature of pavements	40
Pits sunk below sidewalks for refuse	50
Population	107
Removal of snow	114
Street sprinkling	115
Types of carts	116
Unfavorable sanitary situation	110
Use of sweeping machines	113
Billingsgate fish market, London, Cleaning of	66
Borough presidents, New York	162
Boulevards, Paris	86
Brick sewers, Cleaning of, Westminster	80
Broom, Horse-propelled, Berlin	116
Paris	99
Burning of city wastes	34
house refuse	57
Burnt refuse, Utilization of, Manchester	87
Canals, Cleaning, Amsterdam	157
Carts for removal of house and street refuse	50
Paris	104
street sprinkling	51
Types used in Berlin	116
Unsuitability for conveyance of refuse	9
Catch basins, London	69
Westminster	80
Cellar dirt, Meaning of term	36
Cells, Hamburg incinerator	130
Centralization of work	43
Central sanitary authority, Importance of	61
Character of London streets	65
of pavements	39
Charlottenburg, Division of house refuse	56

INDEX

	PAGE
Cheapside, London traffic	65
Chemical ingredients of street dirt	21
Cinder, Meaning of term	36
City dust	7
of London	60
refuse in control.	15
streets, Origin of	3
Uses of	6
wastes, Burning	34
Composting	34
Sea dumping	35
Use as fertilizer	34
Value of	29
What it is	29
Civil engineers, Status of, Germany	108
Cleaning of pavements,	20
Cleansing of courts, London	68
with rubber scrapers	27
Clinker, Meaning of term	36
Utilization of	35
Code of regulations for laborers, Westminster	83
Cholera epidemics, Hamburg	119
Collection and disposal of excreta, Manchester.	87
house refuse,	13, 55
Cologne	147
London	66
Manchester.	87
Paris	102
of night soil, Manchester	87
Collection of refuse, Amsterdam	155
Necessity of promptness	42
Cologne	137
Collection of house refuse	147
Di position of refuse	150
Division of city for street cleaning.	145
Early condition of city streets	138
Opposition to street cleaning	142
Organization of street cleaning forces	143
Removal of snow	149
Street cleaning.	147
Work of street cleaning bureau	144
Committee on Improvements and Finance, London	64

INDEX

	PAGE
Complaints, regarding house refuse, Westminster	78
Composition of refuse and garbage	31
Compost Amsterdam	156
Composting of city wastes	34
Condition of repair of pavement	39
Conduits for underground structures	6
Construction of city of Amsterdam	152
Contaminating matter in air	7
Contracts for street cleaning	28
Contract price for barging refuse, Westminster	75
Control of city refuse	15
Coöperation between city departments	17
Municipal, Germany	110
with householders	18
Cost of burning refuse	57
cleaning of pavements	22
flushing, New York	169
keeping horses, New York	180
labor, Hamburg	135
refuse disposal, Amsterdam	159
removal of house refuse	78
repairs of motors, Westminster	81
running street cleaning department, New York	166
snow removal, Hamburg	126
street cleaning, Berlin	118
Cologne	149
Comparative	25
Manchester	85
New York	180
Paris	106
water, for sewer cleaning, Westminster	81
London	64
Westminster	76
Council in German cities	109
Courts, London, Cleansing of	68
Daily collection of house refuse, Westminster	77
reports, Westminster	74
Day population of London	63
sweepers, Work of, in London	69
work on street cleaning	45
Dead animals, Collection of	37

INDEX

	PAGE
Department of Public Works, Paris	94
Departments for street cleaning, Organization	42
Depots and plants, Westminster	81
Destructors for garbage	34
Difficulties of street cleaning department, New York	167
Dirt, Handling of	36
Meaning of term	36
Street, Use for filling in land	54
Disabled and incompetent men, Westminster	83
Disease germs in street dirt	21
Disposal of dirt in streets	21
house refuse	55
London	71
night soil, Manchester	87
paper	30
refuse	29
street sweepings	53
Disposition of refuse and garbage	31
Division of work of cleaning	45
Drinking-water, Hamburg	120
Dumping places, of wastes	31
Dumps, Management of	30
Dunbar, Dr., Work in Hamburg	120
Dust, Handling of	36
Meaning of term	36
Duty of magistrates	17
Employees, London, Total number of	72
Engineering bureau, Hamburg	121
England, Disposal of house refuse	32
Epidemics, Cologne	139
Equipment for street cleaning, European cities	48
Paris	101
Estimating monitors, New York	178
Exereta, Collection and disposal, Manchester	87
Exhaust products from burning refuse, Hamburg	131
Expenditures of highways department, Westminster	84
street cleaning department, New York	180
Extent and pavement of streets, Manchester	86
Extravagance in street cleaning, Reasons for	11
European methods of street cleaning, General conclusions	58
Summary	38

INDEX

	PAGE
Fertilizer, Use of city wastes	34
Filling in land with street dirt	54
Filter plan, Hamburg	120
Final disposition of refuse, Westminster	79
Flushing by means of hose	47
Estimates for	26
Explanation of term	24
cost, New York	169
Cost of water, Westminster	76
Flushing, Gutters	41
Machines	25
New York	171
Sewers, Westminster	80
Streets	41
Time occupied, Westminster	76
Forces for street work, Organization of	44
Form of carts for removal of refuse	51
hand brooms	49
Fundamental principles	15
Garbage, Composition and disposal of	31
reduction	33
Generation of power from refuse burning, Hamburg	132
Germany, Character of workmen	44
Executive head of city department	109
Municipal government	108
Plan of municipal works	110
Use of street cars for sprinkling	52
Glasgow, Pits for street refuse	51
Gradients, Westminster	73
Greater London	60
Gutters, Flushing	41
in European cities	47
Paris	96
Hamburg, Administrative departments	119
Area of streets cleaned	123
Attractive appearance of city	120
Cost of horses	135
Disposal of street refuse	127
Hygienic institutions	120
In care of laborers	135

INDEX

	PAGE
Hamburg, Incinerator	128
Pits for street refuse	50
Removal of house refuse	127
Removal of snow	125
Sanding of streets	41
Scope of street cleaning work	121
Use of hand-cart	49
Handling of dust and dirt	36
Hand brooms, Forms and materials for	49
scrapers	49
sweepings, New York	168
Hardwood pavements	39
Hauling refuse, Wagons and length of haul	32
Hiring of horses, Berlin	115
Highways committee, Westminster	74
Holidays, Westminster	83
Horse-propelled cart, Paris	101
squeegees	52
sweepers, Manchester	86
Horses, Care of, Hamburg	135
Hose pressure, Absence of, Berlin	117
sprinkling, Paris	101
Use for flushing	47
Householders, Coöperation with city officials	18
Household wastes, Collection of	13
House refuse, Collection and disposal	55
Collection, Cologne	147
Manchester	87
New York	171
Paris	102
Cost of removal, Westminster	78
disposal, Amsterdam	155
Berlin	118
Hamburg	127
London	71
Final disposition	79
Removal in Westminster	77
Results of failure to collect	10
Sorting	56
Utilization	57
Hydrants sunk beneath sidewalk	47
Hygienic institutions, Hamburg	120

INDEX

	PAGE
Implements employed in street cleaning, New York.....	169
Importance of central sanitary authority	61
Incinerators for garbage	34
Hamburg	128
Inefficiency in street cleaning, Reasons for	11
Ingredients of street dirt	21
Insanitary conditions, Cologne	139
Inspector of street cleaning, Berlin	112
Cologne	145
Iron orderly bins	50
Kitchen waste collection	172
Labor	43
Cost of	26
Laborers, Tools and equipment	22
Care of, Hamburg	135
Labor, Quantities and cost, Hamburg	135
required, Hamburg incinerator	134
Lack of coöperation, New York city departments	167
system in street cleaning	28
Length and area of streets, Berlin	113
Liernur system of sewerage	154
Littering of market places	18
Location of receptacles for refuse	19
London, Administrative county	62
An aggregation of cities	60
Authority over street cleaning	64
Center of city	63
Central sanitary authority	61
Character of streets	65
City of Westminster	73
Cleansing of courts	68
Collection of house refuse	66
Control of street conditions	43
Cost of water	64
County council	62
Disposal of house refuse	71
Flushing of streets	48
Main drainage system	62
Market places	66
Metropolitan Board of Works	61
Police District	60

INDEX

	PAGE
London, Multiplicity of highway authorities	62
Night and day population	63
Number and age of employees on street work	72
Orderly bins	50
Public health department	43
Removal of snow	70
Sale of street refuse	54
Sanding of pavements	67
Scope of work of committees	64
Street washing	65
Traffic	65
Use of hose for flushing	48
salt for removal of snow	55
self-propelled vehicles	71
water carts	47
Weather conditions	67
What it is	60
Macadam pavement, Cleaning	40
Machine brooms and scraper, Paris	100
Flushing	25
labor, Substitution for hand labor	44
Sprinkler, Use in Antwerp	48
Sweeping	32
Magistrates, Duty of	17
Germany	199
Main drainage system of London	62
sources of street dirt	9
Management of dumps	30
Manchester, England	85
Area	86
Collection and utilization of excreta	87
of house refuse	87
Cost of street cleaning	85
Extent and pavement of streets	86
Material handled	86
Method of street cleaning	86
Population	85
Quantities of material	86
Street cleaning authority	85
Market places, London	66
Unavoidable littering of	18

INDEX

	PAGE
Material handled by street cleaning department, Manchester	86
Materials for hand brooms	49
Mayors, Germany	108
Mechanical sweepers	48
Methods of city work, New York	168
street cleaning	21
Cologne	141
Comparative costs	25
European cities	45
Manchester	86
Paris	95
flushing, Westminster	75
sweeping	22
Metropolitan Board of Works, London	61
Police District, London	60
Microbic ingredients of street dirt	21
Military organization of street cleaning force	111
Motors for work on streets	52
Motor sprinkler, Berlin	51
Motors, Utility of, Westminster	81
Motor water wagons, Westminster	76
Multiplicity of highway authorities in London	62
Municipal development, Berlin	108
growth in America and Europe	2
sanitary institutions, Hamburg	120
Nature of pavements	39
Necessity of coöperation in preventive work	17
New York	161
Collection of house refuse	171
Comparative cost of street cleaning	25
Cost street cleaning department	180
Duties of street cleaning department	166
Methods of work	168
Origin of street cleaning department	163
Plan of street cleaning department	174
Plant and apparatus owned by street cleaning department	180
Property street cleaning department	179
Removal of snow	176
Sanitary utilization company	173
Statistics of boroughs	163

INDEX

	PAGE
New York, Statistics of pavements	171
Street cleaning districts	166
problem	165
Use of hand scrapers	49
Night cleaning, London	68
population of London	63
Nightsoil, Collection and disposal, Manchester	87
Night work	46
North Sea canal	153
Number of employees, London	72
Official investigations street cleaning department, New York	163
Orderlies	46
London	69
Posts of, Hamburg	124
Work of, Hamburg	123
Ordinances, Sanitary regulation by police	16
Organization of forces	44
Westminster	74
street cleaning departments	42
New York	165
Cologne	143
Hamburg	121
Origin of city streets	3
street cleaning department, New York	163
Overcrowding in European cities	2
Papers and rubbish collection, New York	175
Paper waste, Disposal of	30
Paris, Collection of house refuse	102
refuse from streets	50
Cost of street cleaning	106
Disposal of snow	104
street sweepings	53
Flushing of gutters	41
street dirt into sewers	46
Gutter flushing	47
Nature of pavements	40
Population	94
Ragpickers	56
Sewers	21

INDEX

	PAGE
Paris, Sorting of refuse	56
Street cleaning authority	94
Use of rotary broom and squeegees	46
Use of salt for removal of snow	55
Pavement, Character and condition of repair	39
Nature of	39
of streets, Manchester	86
Pavements, Asphalt	39
Cleaning of	20
Condition of	21
Cost of cleaning	22
Macadam	40
Mileage and area, New York	171
Sanding	76
Stone	40
Total surface cleaned, Paris	105
Use of sand, Hamburg	124
Use of water in cleaning	24
Wood	39
Personal interest in work	44
Personnel of street cleaning force, Paris	94
Physical properties of street dirt	20
Pits for street dirt, Berlin	50
refuse	117
Hamburg	124
Plant and equipment employed for street cleaning	48
Police regulation of sanitary ordinances	16
Political conditions, New York	164
Population, Manchester	85
New York	163
Paris	94
Westminster	73
Portable cans for removal of house refuse	56
Posts for orderlies, Hamburg	124
Power consumption, Hamburg incinerator	133
Preliminary wetting of pavements	48
Prevention of disease, Hamburg	128
Preventive work in tenement districts	18
Private receptacles for house refuse	32
scavengers, New York	167
Profitable use of city wastes	29
Prompt collection of refuse	42

INDEX

	PAGE
Public Health department	43
London	64
Public receptacles for refuse	19
Public scavenger	18
Quantities of material handled by street cleaning department, Manchester	86
Ragpickers in Paris	56, 95, 102
Reasons for extravagance in street cleaning	11
Receptacles, Private, for house refuse	32
Public, Location of	19
for refuse	19
rubbish, Paris	103
Reduction of garbage	33
refuse, New York	172
Refuse, Barges for removal	33
burning utilization for power, Hamburg	132
city, Control of	15
Collection, Amsterdam	157
Cologne	146
Paris	50, 95
Composition and disposal of	31
Composting, Amsterdam	156
Cost of barging, Westminster	75
destructor, Cologne	150
Hamburg	129
Westminster	79
Disposal of	29
disposal, New York	180
Final disposition, Cologne	150
furnaces	35
house, Result of failure to collect	10
Prompt collection	42
Public receptacles for	19
Quantity burned, Hamburg incinerator	133
Refuse inspector, Westminster	78
Refuse, Street, Division of	38
Use of streets as receptacles	8
Utilization of	29
Wagons for hauling	32
Regeneration of Hamburg	119

INDEX

	PAGE
Removal of house refuse, Westminster	77
refuse on barges	33
snow	54
London	70
Reports of sewer foremen, Westminster	80
Responsibility for street work	44
Residue from burning of refuse, Use of	58
Reward and sick allowances, Berlin	112
for faithful conduct, Westminster	83
Rotary brooms, Use in Paris	46
sweepers	52
Rubber scrapers, Cleansing with	27
Rubbish, Composition and disposal of	31
Salaries, German officials	109
Salt, Use in London for removal of snow	71
street cleaning	55
Sanding of pavements, London	67
streets	41
Westminster	76
Sand used on pavements, Hamburg	124
Use of, Paris	96
Sanitary advantages of destroying refuse	57
authority centralized	61
code, Disobedience of	17
ordinances and the police	16
progress in Europe	2
regeneration of Berlin	107
situation, Berlin	110
Sanitation, Aim of	15
Scavenger wagons, Dust-proof	32
Scope of work of committees, London	64
Sweeping machines	23
Sea dumping	35
Self-propelled vehicles in London	71
Sewage disposal, Amsterdam	154
Cologne	138
Hamburg	120
farms, Paris	98
Sewer cleaning, Westminster	79
inspector	79
Sewers of Paris	98

INDEX

	PAGE
Sick allowance, Berlin	112
Sidewalks, Cleaning	41
Manchester	86
Snow, Disposal of, Paris	104
plows used in New York	179
Use of	55
Removal	54
Amsterdam	159
Berlin	114
Cologne	149
Cost, Hamburg	126
Hamburg	125
London	70
New York	176
Sorting of house refuse	56
Spasmodic cleaning of streets	12
Speedy removal of house refuse, Westminster	79
Sprinkler and squeegee electrically driven, Berlin	117
Sprinkling	27
cart motor driven, Berlin	116
carts, Paris	101
of streets	42
Amsterdam	158
Berlin	115
Cologne	148
Hamburg	125
wagons, Cologne	147
with hose, Paris	101
oil	27
Squeegees, Horse broom, Paris	99
Horse-propelled	52
Berlin	114
Use of	27
Hamburg	123
Paris	46
Standard cart and sweeper, New York	174
Stone pavement, Cleaning	40
Statistics, Expenditures for New York street cleaning department of New York City	181 163
Street cleaning, Amsterdam	158
authority, Berlin	111
London	64

INDEX

	PAGE
Street cleaning, authority, Manchester	85
Westminster	73
Bureau, Cologne	144
City department <i>vs.</i> contract	13
Cost, Berlin	118
Cologne	149
Manchester	85
Paris	106
department, Amsterdam	156
Duties of, New York	166
Hamburg, Extra work done	135
New York	162
Present organization	165
Organization of	42
Uniforms for	45
Division of work	45
equipment, Paris	101
European methods	38
force, Amsterdam	159
Berlin	112
Westminster	82
Frequency of, Cologne	146
General observations	41
Hamburg	122
Methods	21
Methods in Manchester	86
Paris	95
Most expensive feature	26
Night and day work	122
Organization, Cologne	143
Hamburg	121
Plant and equipment	48
plant, Hamburg	136
Reasons for extravagance and inefficiency	11
Relative efficiency of hand and machine	25
Responsibility for	44
Spasmodic work	12
work, Scope of, in Paris	94
Street conditions, Authority for	43
dirt, Disposal of	54
Facility of removal	24

INDEX

	PAGE
Street dirt, Ingredients of	21
Main sources of	9
Physical properties of	20
Street flushing	41
Westminster, Methods	75
Improvement, Paris, Cost	86
laborers	13
orderly work, Berlin	117
refuse disposal, Hamburg	127
Division of	38
scraper, Paris	100
sprinkling	42
Carts for	51
Use of street cars in Germany	52
sweeping, Methods of	22
sweepings, New York	168
Disposal of	53
removal, Berlin	114
Manchester	86
Meaning of term	36
washing, London	65
Streets, Area of, Berlin	113
as receptacles for refuse	8
City, Origin of	3
Uses of	6
Berlin	110
Insanitary condition, Cologne	142
London, Character of	65
Sanding	41
Substitution of machine labor for hand labor	44
Success in street cleaning, Necessity of coöperation	17
Sulphate of ammonia products at Amsterdam	155
Sunday work, London	70
Supervision of removal of house refuse	78
Sweeping machines	52
Berlin	113
Manchester	86
Paris	95
Sweepings, Street	36
System, Lack of in street cleaning	28
Teaming cost, Berlin	114

INDEX

	PAGE
Tenement districts, Preventive work in	78
Tide rise and fall, Amsterdam	154
Time occupied in flushing, Westminster	76
Tools and equipment of street laborers	22
Trade refuse, London disposal of	71
Traffic, London	65
Transportation bureau, Cologne	144
Traveling ganger, Westminster	74
Treatment of liquid, Manchester	88
Types of apparatus employed for street cleaning	48
Underground pits, Hamburg	124
Uniforms for street cleaning department.....	45
Berlin	112
Use of city waste as fertilizer	34
Uses of city streets	6
Utility of motors for removal of refuse	81
Utilization of ashes and clinker	35
excreta, Manchester	87
heat from burning of refuse	57
house refuse	57
refuse	29
rubbish, New York	175
street sweepings	53
waste, Hamburg incinerator	131
New York	173
works, Amsterdam	155
Vacations and sick pay, Paris	98
Value of city wastes	29
Wages of street cleaning force, Germany	112
New York	169
Wagons for hauling refuse	32
removal of house refuse, Hamburg	128
Waring, Col. Geo. E.....	165
Washing of asphalt streets, Berlin	115
streets, London	65
Wastes, City, Burning	34
Sea dumping	35
Use for fertilizer	34

INDEX

	PAGE
Wastes, City, Value of	29
What it is	29
Dumping places	31
Sale of, Berlin	113
Water carts, Use in London	47
for cleansing pavements	24
front, New York	161
Use and flushing gutters, Paris	96
Weather conditions affecting cleaning of streets	67
Weekly collection of house refuse, Westminster	77
Weight clerks, Westminster	74
Westminster, London	73
Authority over street cleaning	73
Cleaning of sewers	79
Daily report	74
Depots under supervision of highway department	81
Final disposition of house refuse	79
Method of street flushing	75
Motors for removal of refuse	81
Motor water wagons	76
Organization of forces	74
Price for braging refuse	75
Removal of house refuse	77
Scattering of sand	76
Street cleaning force	82
sprinkling	42
Women in street work	44
Wood pavement, Cleaning	39
Difficulties of cleaning	40
Work of horse brooms, Paris	99
Orderlies, Berlin	117
London	69

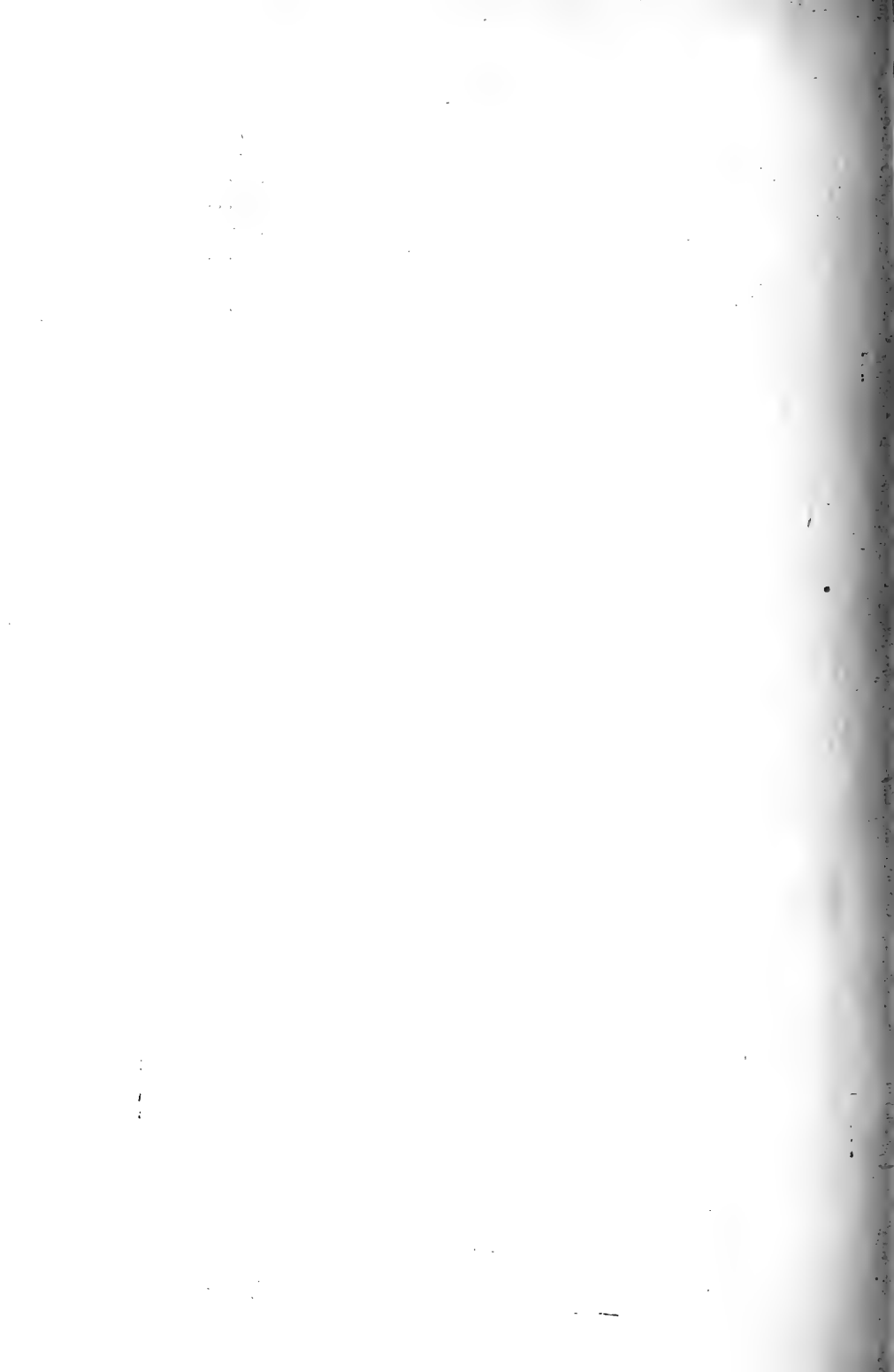



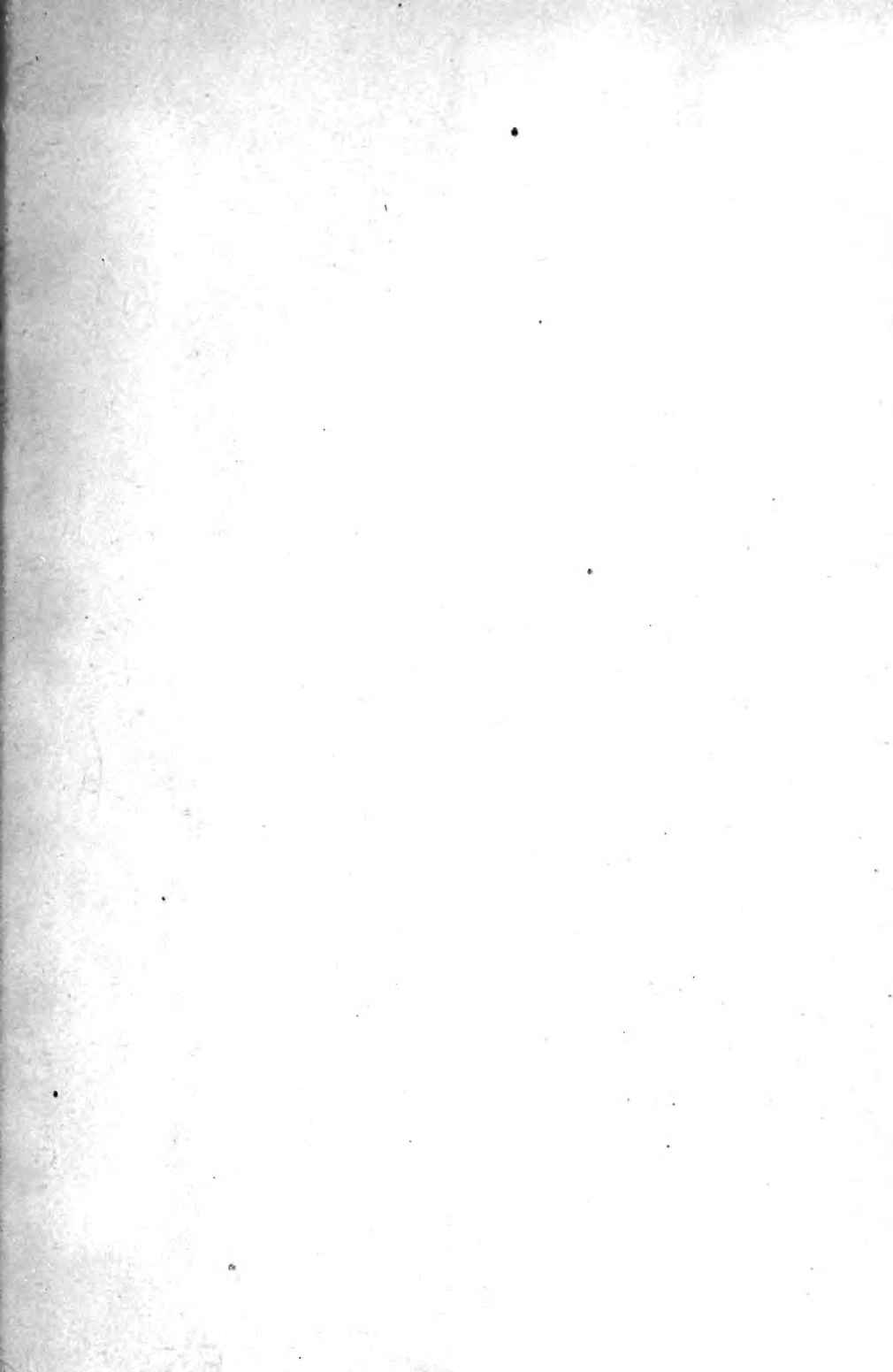



UNIVERSITY OF TORONTO
DEPARTMENT OF ELECTRICAL ENGINEERING
Multiphase and Digital

PLEASE DO NOT REMOVE
CARDS OR SLIPS FROM THIS POCKET

UNIVERSITY OF TORONTO LIBRARY

S&M
A
496

