



Class SB195

Book S16

Copyright N^o _____

COPYRIGHT DEPOSIT.

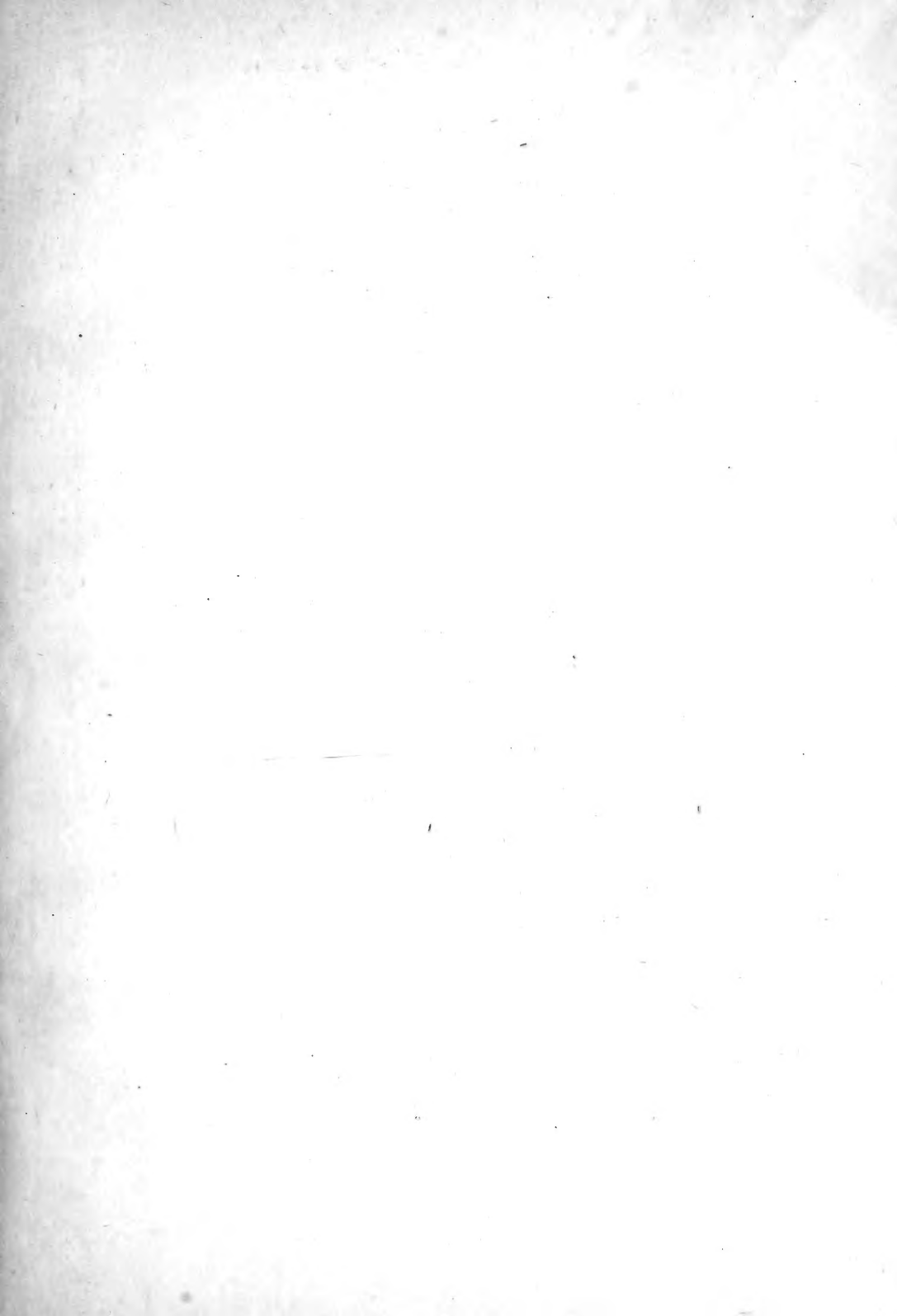

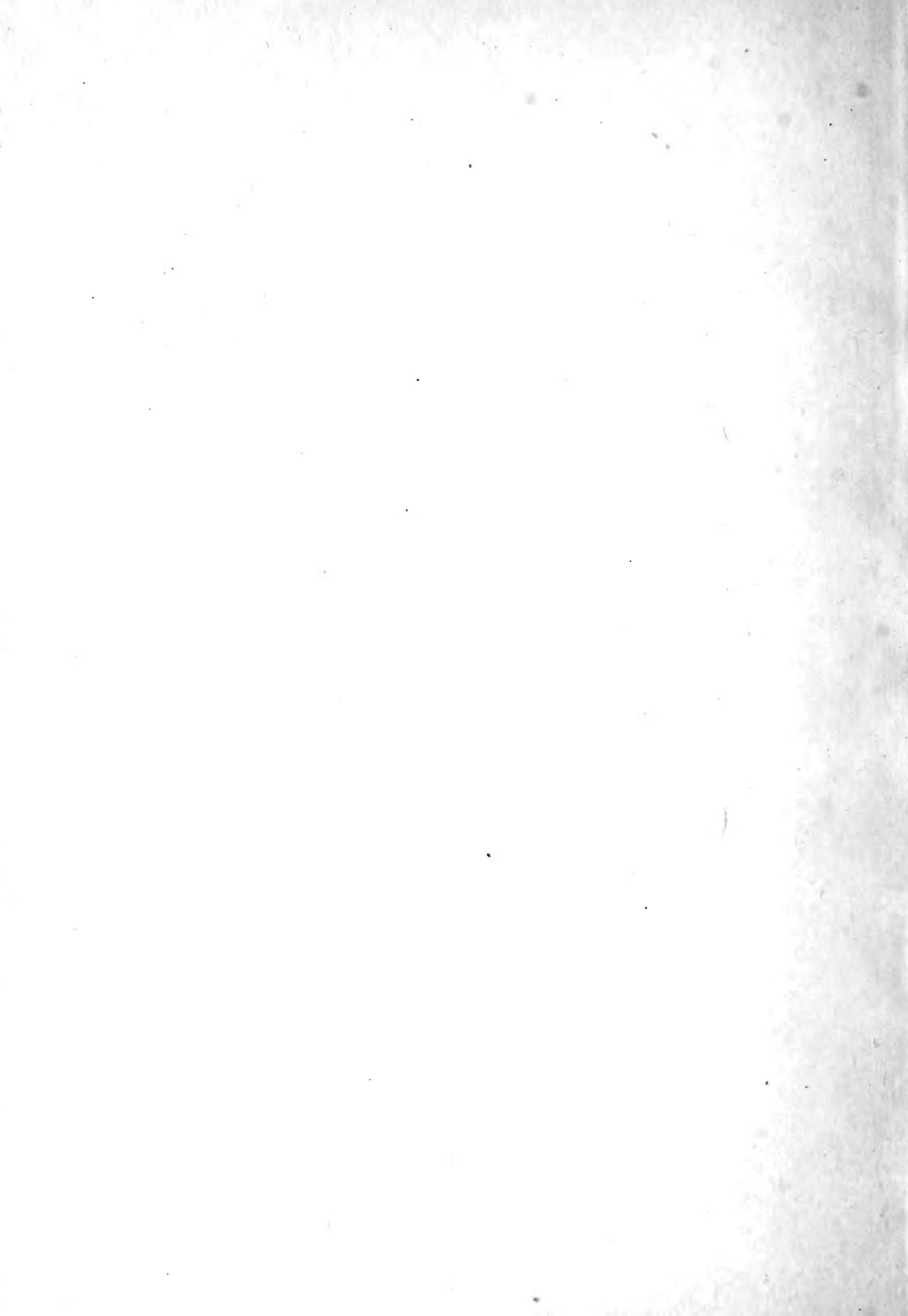

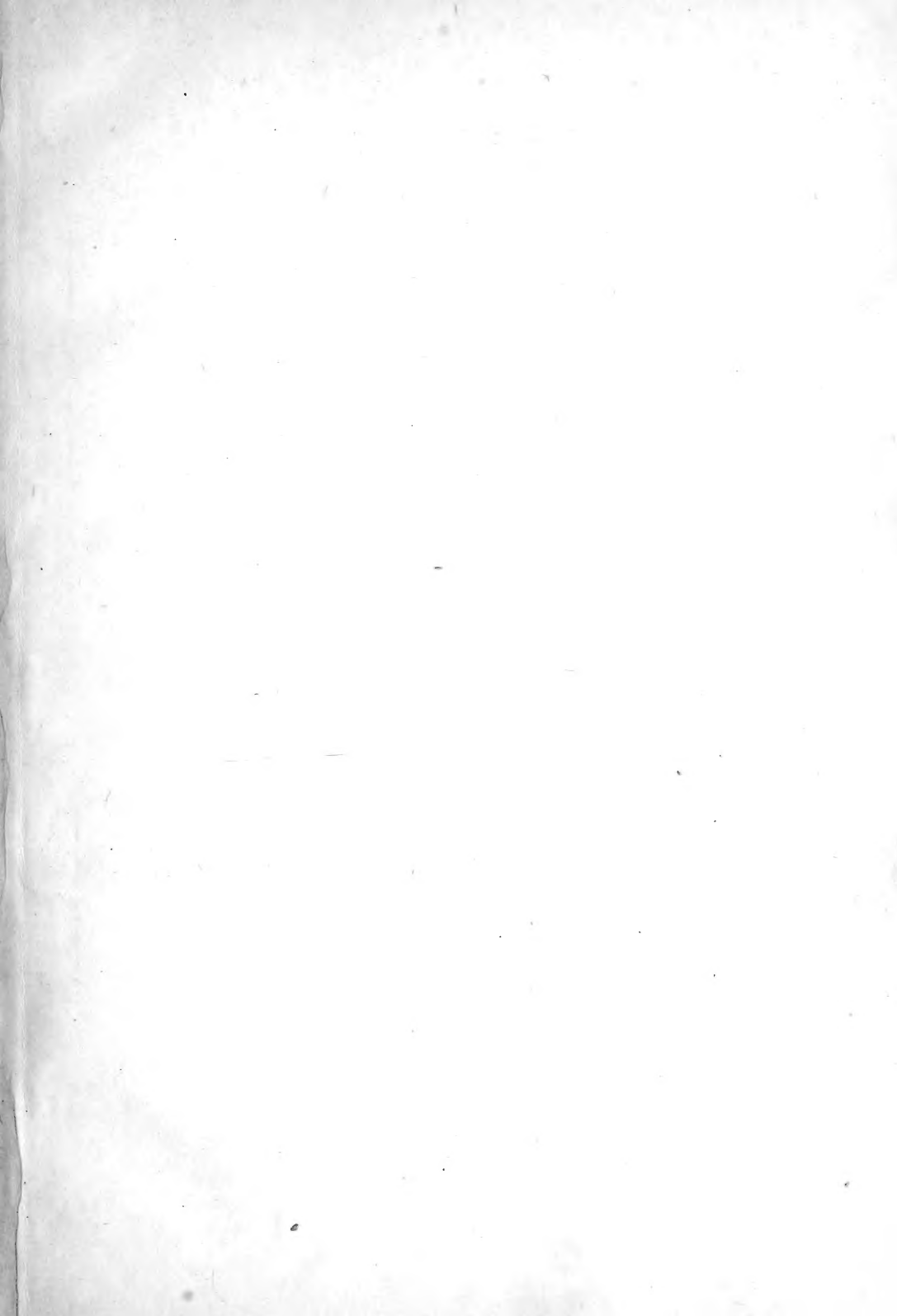

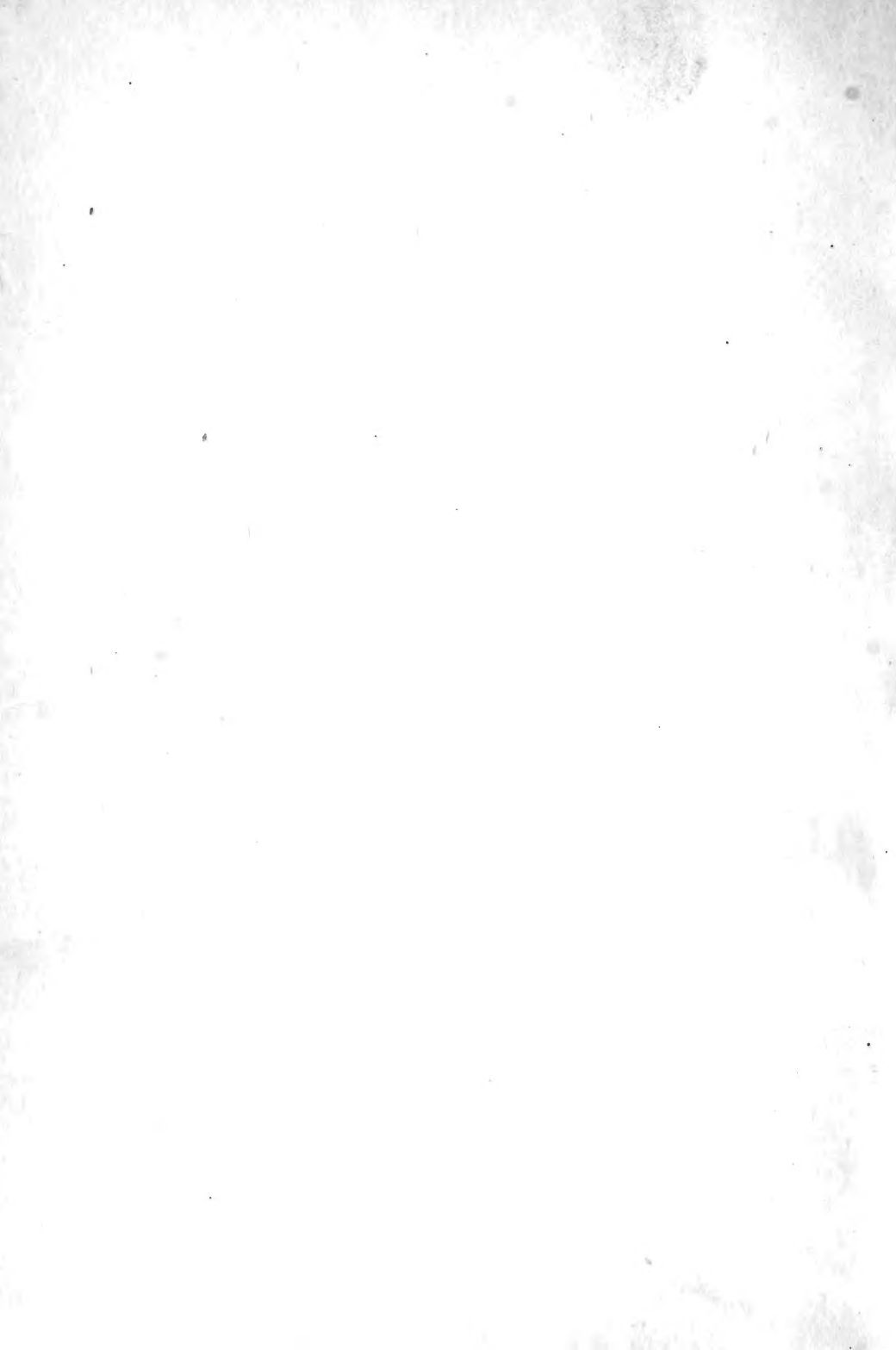

MODERN SILAGE METHODS

801

720

LATEST REVISED EDITION
WITH ILLUSTRATIONS

An entirely new and practical work on Silos, their construction and the process of filling, to which is added complete and reliable information regarding Silage and its composition; feeding, and a treatise on rations, being a

FEEDERS' AND DAIRYMEN'S GUIDE

PUBLISHED
AND COPYRIGHTED BY

THE SILVER MANUFACTURING CO.

SALEM, OHIO

U. S. A.

1911

SB195

S6

Copyrighted 1911, by
THE SILVER MANUFACTURING Co.

CHICAGO
W. B. CONKEY COMPANY
1911

©Cl.A281395

Feb. 13, 1911

PREFACE.

and

This book has been written and published for the purpose of furnishing our patrons and others with accurate and full information on the subject of silo construction and the making of silage. It has been the aim of the authors to present the subject in a clear matter-of-fact manner, without flourish or rhetoric or flight of imagination, believing that the truth concerning the advantages of the siloing system is good enough. The testimony presented, which is purposely kept close to the experience of authorities on feeding subjects in and outside of experiment stations, will abundantly prove, we believe, that the equipment of an American dairy or stock farm is no longer complete without one or more silos on it.

The new chapters on "The Summer Silo," "The Use of Silage in Beef Production," and "Concrete and Cement Block Silos" will be found especially timely, and in other respects the book has been brought up-to-date.

In order that a work of this kind be accurate and reliable, and bear the scrutiny of scientific readers, the use of a number of scientific terms and phrases is rendered necessary, and in order that these may be more readily comprehended by Agriculturists, a comprehensive glossary or dictionary of such terms is included, following the last chapter, which can be referred to from time to time, or can be studied previous to reading the book.

In the compilation of certain parts of the book we have had the valuable assistance of Prof. Woll, of Wisconsin Experiment Station, author of "A Book on Silage" and "A Handbook for Farmers and Dairymen." Free use of the former book has been made in the preparation of this volume, as well as of experiment station publications treating the subject of silage.

Hoping that this latest revision of "Modern Silage Methods" will prove helpful to our patrons, and incidentally suggest to them that the Ohio Silage Cutters and Blower Elevators are manufactured by us, we are,

Very truly,

THE SILVER MFG. CO.

TABLE OF CONTENTS.

PREFACE	3
INTRODUCTORY	7-10

CHAPTER I.

Advantages of the Silo—Preservation of a larger quantity of original food value enabled by the use of the Silo than any method known—Losses of nutritive value in dry curing—Small losses in the Siloing process—The Silo furnishes a feed of uniform quality—Economy of making—Economy of Storage—No danger of rain—No danger of late summer droughts—Food from thistles—Value in intensive farming.....11-22

CHAPTER II.

Summer Silos.

Necessary in supplementing summer pastures and in tiding herd over period of drouth, heat and flies—Avoids labor of soiling crop system—Purdue Station Experiments—Comments by the agricultural press.....23-27

CHAPTER III.

Silage in Beef Production.

A substitute for roots for fattening cattle—Prevents “burning out” of steers—500-ton silo for steers only—Advantages to the beef feeder—Experiments at the Ohio and Indiana Stations—At the Kansas and Iowa Stations—Experience of one of largest beef cattle feeders in East—Prof. Soule’s experiments in the South—Silage good for stockers.....28-41

TABLE OF CONTENTS.

CHAPTER IV.

Silage System and Soil Fertility.

Helps maintain soil fertility—Every crop grown robs soil of fertilizing elements—Restoration has vital bearing on our crop yields—Value of barnyard manure—Every farm a manure factory with silage—Keeping fertility on the farm.....42-47

CHAPTER V.

How to Build a Silo.

Silos—General requirements for silo structures—On the size of silo required—On the form of silos—Relations of horizontal feeding—Area and number of cows kept—Location of the silo—Different types of silo structures—Round wooden silos—The silo roof—Modifications of the Wisconsin Silo—Plastered round wooden Silos—Brick-lined Silos—Stave Silos—Cheap Stave Silos—A modification of a Stave Silo—Connecting round silos with the barn—Other forms of round silos—Brick and stone Silos—Silos in the barn—Octagonal Silos—Cost and estimates for different kinds.... 48-120

CHAPTER VI.

Concrete or Cement Silos.

"The silo of the future" where permanence is desired—Possibilities of reinforced concrete—Continuous hollow walls—Importance of strong foundation—A Missouri concrete silo—"Forms" used for monolithic wall—Cement Blocks; how made—To maintain cement lining—Reinforced cement blocks—Cement block silos described121-132

CHAPTER VII.

Silage Crops—Indian Corn—Silos best adapted to corn culture and preparation of land—Varieties of corn for the silo—Time of cutting corn for the silo—Methods of planting corn—Other silage crops.....133-148

CHAPTER VIII.

Filling the Silo—Indian Corn—Siloing corn “ears and all” —The filling process—The proper distribution of cut material in the silo—Size of cutter and power required —Length of chain elevator required—Directions for operating “Ohio” Blower Cutters—Danger from car- bonic-acid poisoning in silos—Covering the siloed fod- der—Use of water in filling silos—Clover for summer silage—Freezing of silage.....	149-166
---------------------------------------------------------------------------------------------------------------------------------------------------------------------------------------------------------------------------------------------------------------------------------------------------------------------------------------------------------------------------------------------------------------------------------------	---------

CHAPTER IX.

How to feed silage—Silage for milch cows—Silage in the production of certified milk—Silage for beef cattle— for Horses—for Sheep—for Swine—Silage for poultry —Additional testimony as to the advantage of silage— Corn silage as compared with root crops—Corn silage as compared with hay—Corn silage compared with fodder corn	167-189
-----------------------------------------------------------------------------------------------------------------------------------------------------------------------------------------------------------------------------------------------------------------------------------------------------------------------------------------------------------	---------

CHAPTER X.

A feeder's guide—Composition of the animal body—Com- position of feeding stuffs—Digestibility of foods—Rela- tive value of feeding stuffs—Feeding standards—How to figure out rations—Grain mixtures for dairy cows— Average composition of Silage crops of different kinds, in per cent—Analysis of Feeding stuffs—Ready refer- ence tables	190-215
----------------------------------------------------------------------------------------------------------------------------------------------------------------------------------------------------------------------------------------------------------------------------------------------------------------------------------------------------------------------	---------

CONCLUSION	216
GLOSSARY	217-219
INDEX	220-224

Modern Silage Methods.

INTRODUCTION.

Twenty-five years ago few farmers knew what a silo was, and fewer still had ever seen a silo or fed silage to their stock. Today silos are as common as barn buildings in many farming districts in this country, and thousands of farmers would want to quit farming if they could not have silage to feed to their stock during the larger portion of the year. Twenty-five years ago it would have been necessary to begin a book describing the siloing system with definitions, what is meant by silos and silage; now all farmers who read agricultural papers or attend agricultural or dairy conventions are at least familiar with these words, even if they do not have a chance to become familiar with the appearance and properties of silage. They know that a SILO is an air-tight structure used for the preservation of green, coarse fodder in a succulent condition, and that SILAGE is the feed taken out of a silo.

We shall later see which crops are adapted for silage making, but want to state here at the outset that Indian corn is pre-eminently the American crop suited to be preserved in silos, and that this crop is siloed far more than all other kinds of crops put together. When the word silage is mentioned we, therefore, instinctively think of corn silage. We shall also follow this plan in the discussions in this book; when only silage is spoken of we mean silage made from the corn plant; if made from other crops the name of the crop is always given, as clover silage, peavine silage, etc.

History of the Silo. While the silo in one form or another dates back to antiquity, it was not until the latter part of the seventies that the building of silos intended for manufacture of silage began in this country. In 1882 the United States Department of Agriculture could find only ninety-one farmers in this country who used silos. During the last twenty-five years, however, silos have gradually become general in all sections of the country where dairying and stock-raising are important industries; it is likely, if a census were taken of the number of silos in this country today, that we would find between a half and three-fourths of a million of them. The silo is today considered a necessity on thousands of dairy farms, and we find most of them in the states that rank first as dairy states, viz.: New York, Iowa, Illinois, Wisconsin, Pennsylvania, etc. The farmers that have had most experience with silage are the most enthusiastic advocates of the siloing system, and the testimony of intelligent dairymen all over the country is strongly in favor of the silo. Said a New York farmer recently in one of our main agricultural papers: "I would as soon try to farm without a barn as without a silo," and another wrote, "I wouldn't take a thousand dollars for my silo if I could not replace it." The well-known agricultural writer, Joseph E. Wing, says: "No stock feeder who grows corn can afford to ignore the silo." "Buff Jersey," an Illinois dairy farmer and writer on agricultural topics, declares his faith in silage as follows: "I am fully satisfied that silage is a better feed, and a cheaper one, than our pastures." Another writer says: "The silo to my mind presents so many advantages over the system of soiling that it is bound to eventually do away with the use of soiling crops." According to the Cornell Experiment Station, the "silo, especially to the dairy farmer, has become an almost necessary adjunct to the equipment of the farm."

Our first effort in writing this book will be to present facts that will back up these statements, and show the reader the many advantages of the silo, over other

systems of growing and curing crops for the feeding of farm animals. We shall show that up-to-date dairy or stock farming is well nigh impossible without the aid of a silo. The silo enables us to feed live stock succulent feeds the year around, and preserves the fodder in a better condition and with less waste than any other system can. We shall see the why and wherefore of this in the following pages, and shall deal with the best way of making and feeding silage to farm animals. We wish to state at the outset that we do not propose to indulge in unwarranted statements or claims that will not stand the closest investigation. In the early days of the history of the silo movement it was thought necessary to make exaggerated claims, but this is no longer the case. Naked facts are sufficient to secure for the silo a permanent place among the necessary equipment of a modern dairy or stock farm. In discussing the silo we shall keep close to what has been found out at our experiment stations, and, we believe, shall be able to prove to any fair-minded reader that the silo is the greatest boon that has come to modern agriculture since the first reaper was manufactured, and that with competition and resulting low prices, it will be likely to become more of a necessity to our farmers in the future than it has been in the past. We aim to convince our readers that the most sensible thing they can do is to plan to build a silo at once if they do not now have one. It is unnecessary to argue with those who are already the happy possessors of a silo, for it is a general experience where a farmer has only provided for immediate wants in building his silo that he will build another as soon as he has had some experience with silage and finds out how his stock likes it, and how well they do on it.

Modern practice has proved that no man need say "I cannot afford a silo," because any farmer who is at all handy with hammer and saw can provide a silo large enough for a medium-sized dairy with very little actual outlay of money. And this same built-at-home silo will

earn for its owner money to build another, and enlarge his herd.

We shall give directions for building several kinds of such silos on the following pages. While they will not be apt to last as long, and therefore are not perhaps as economical in the long run as more substantially-built silos, still they do excellent service until some experience with making and feeding silage has been obtained, or until the farmer can afford to put up a more substantial structure.

We mention this fact here to show farmers who may be considering the matter of building a silo, or who may be inclined to think that the silo is an expensive luxury, only for rich farmers, that the cost of a silo need not debar them from the advantages of having one on their farm, and thus secure a uniform succulent feed for their stock through the whole winter. Farmers who have not as yet informed themselves in regard to the value of the silo and silage on dairy or stock farms, are respectfully asked to read carefully the following statements of the advantages of the silo system over other methods of preserving green forage for winter or summer feeding.

It has been said that "Whoever makes two blades of grass grow where but one grew before is a benefactor to mankind." A silo makes it possible to keep two cows where but one was kept before, and who would not gladly double his income? Does not this interest you?

CHAPTER I.

ADVANTAGES OF THE SILO.

The silo enables us to preserve a larger quantity of the food materials of the original fodder for the feeding of farm animals than is possible by any other system of preservation now known. Pasture grass is the ideal feed for live stock, but it is not available more than a few months in the year. The same holds true with all soiling crops or tame grasses as well. When made into hay the grasses and other green crops lose some of the food material contained therein, both on account of unavoidable losses of leaves and other tender parts, and on account of fermentations which take place while the plants are drying out or being cured.

In cases of Indian corn the losses from the latter source are considerable, owing to the coarse stalks of the plant and the large number of air-cells in the pith of these. Under the best of conditions cured fodder corn will lose at least ten per cent. of its food value when cured in shocks; such a low loss can only be obtained when the shocks are cared for under cover, or out in the field under ideal weather conditions. In ordinary farm practice the loss in nutritive value will approach twenty-five per cent., and will even exceed this figure unless special precautions are taken in handling the fodder, and it is not left exposed to all kinds of weather in shocks in the field through the whole winter. These figures may seem surprisingly large to many farmers who have left fodder out all winter long, and find the corn inside the shock bright and green, almost as it was when put up. But appearances are deceitful; if the shocks had been weighed as they were put up, and again in the late

winter, another story would be told, and it would be found that the shocks only weighed anywhere from a third to a half as much as when they were cured and ready to be put in the barn late in the fall; if chemical analysis of the corn in the shocks were made late in the fall, and when taken down, it would be found that the decrease in weight was not caused by evaporation of water from the fodder, but by waste of food materials contained therein from fermentations, or actions of enzymes. (See Glossary.)

The correctness of the figures given above has been abundantly proved by careful experiments conducted at a number of different experiment stations, notably the Wisconsin, New Jersey, Vermont, Pennsylvania, and Colorado experiment stations. A summary of the main work in this line is given in Prof. Woll's Book on Silage. In the Wisconsin experiments there was an average loss of 23.8 per cent. in the dry matter (see Glossary), and 24.3 per cent. of protein, during four different years, when over 36 tons of green fodder had been put up in shocks and carefully weighed and sampled at the beginning and end of the experiment. These shocks had been left out for different lengths of time, under varying conditions of weather, and made from different kinds of corn, so as to present a variety of conditions. The Colorado experiments are perhaps the most convincing as to the losses which unavoidably take place in the curing of Indian corn in shocks. The following account is taken from Prof. Cook's report of the experiments. As the conditions described in the investigation will apply to most places on our continent where Indian corn is cured for fodder, it will be well for farmers to carefully look into the results of the experiment.

"It is believed by most farmers that, in the dry climate of Colorado, fodder corn, where cut and shocked in good shape, cures without loss of feeding value, and that the loss of weight that occurs is merely due to the drying out of the water. A test of this question was made

in the fall of 1893, and the results obtained seemed to indicate that fully a third of the feeding value was lost in the curing. This result was so surprising that the figures were not published, fearing that some error had crept in, though we could not see where there was the possibility of a mistake.

"In the fall of 1894 the test was repeated on a larger scale. A lot of corn was carefully weighed and sampled, it was then divided into three portions; one was spread on the ground in a thin layer, the second part was set up in large shocks, containing about five hundred pounds of green fodder in each, while the rest was shocked in small bundles. After remaining thus for some months, until thoroughly cured, the portions were weighed, sampled and analyzed separately. The table gives the losses that occurred in the curing.

	Large Shocks.		Small Shocks.		On the Ground.	
	Total Weight	Dry Matter	Total Weight	Dry Matter	Total Weight	Dry Matter
	Lbs.	Lbs.	Lbs.	Lbs.	Lbs.	Lbs.
When Shocked	952	217	294	77	186	42
After Curing	258	150	64	44	33	19
Loss in Weight	694	67	230	33	153	23
Per Cent of Loss.....	73	31	78	43	82	55

"So far as could be told by the eye, there had been no loss. The fodder had cured in nice shape, and the stalks on the inside of the bundles retained their green color, with no sign of molding or heating. And yet the large shocks had lost 31 per cent. of their dry matter, or feeding value; the small shocks 43 per cent. and the corn spread on the ground 55 per cent.

"On breaking or cutting the stalks these losses were explained. The juice was acid, and there was a very strong acid odor, showing that an active fermentation

was taking place in this seemingly dry fodder. We had noticed this strong odor the fall before and all through the winter. When the fodder corn for the steers is put through the feed cutter that same strong smell is present.

"It can be said, then, that the dryness of the climate in Colorado does not prevent fodder corn from losing a large part of its feeding value through fermentation. Indeed, the loss from this source is fully as great as in the damp climate in New England.

"As compared with the losses by fermentation in the silo, the cured fodder shows considerably the higher loss."

In experiments at the Wisconsin station eleven shocks cured under cover in the barn lost on an average over 8 per cent. of dry matter and toward 14 per cent. of protein. In an experiment at the Maine station over 14 per cent. of dry matter was lost in the process of slow drying of a large sample of fodder corn under the most favorable circumstances. "It is interesting to note that this loss falls almost entirely on the nitrogen-free extract, or carbohydrates (see Glossary), more than two-thirds of it being actually accounted for by the diminished percentage of sugars."

Since such losses will occur in fodder cured under cover with all possible care, it is evident that the average losses of dry matter in field-curing fodder corn, given in the preceding, by no means can be considered exaggerated. Exposure to rain and storm, abrasion of dry leaves and thin stalks, and other factors tend to diminish the nutritive value of the fodder, aside from the losses from fermentations, so that very often only one-half of the food materials originally present in the fodder is left by the time it is fed out. The remaining portion of the fodder has, furthermore, a lower digestibility and a lower feeding value than the fodder corn when put up, for the reason that the fermentations occurring during the curing process destroy the most valuable and easily digestible part, i e., the sugar and starch of the nitrogen-

free extract, which are soluble, or readily rendered soluble, in the process of digestion.

2. **Losses in the Siloing Process.** As compared with the large losses in food materials in field-curing of Indian corn there are but comparatively small losses in the silo, caused by fermentation processes or decomposition of the living plant cells as they are dying off. The losses in this case have been repeatedly determined by experiment stations, and, among others, by those mentioned in the preceding. The average losses of dry matter in the fodder corn during the siloing period of four seasons (1887-'91) as determined by Prof. Woll at the Wisconsin Experiment Station was about 16 per cent. The silos used in these trials, as in case of nearly all the early experiments on this point, were small and shallow, however, only 14 feet deep, were rectangular in form, and not always perfectly air-tight, a most important point in silo construction, as we shall see, and a portion of the silage therefore came out spoilt, thus increasing the losses of food materials in the siloing process. The losses reported were, therefore, too great, and there is now an abundance of evidence at hand showing that the figures given are higher than those found in actual practice, and the necessary loss in the silo comes considerably below that found in the early experiments on this point. There are plenty of cases on record showing that ten per cent. represents the maximum loss of dry matter in modern deep, well-built silos. The losses found in siloing corn at a number of experiment stations during the last ten years have come at or below this figure. It is possible to reduce the loss still farther by avoiding any spoilt silage on the surface, by beginning to feed immediately after the filling of the silo, and by feeding the silage out rather rapidly. Experiments conducted on a small scale by Prof. King in 1894 gave losses of only 2 and 3 per cent. of dry matter, on the strength of which results, amongst others, he believes that the necessary loss of dry matter in the Silo need not exceed 5 per cent.

Summarizing our considerations concerning the relative losses of food materials in the field-curing and siloing of Indian corn, we may, therefore, say that far from being less economical than the former, the silo is more so, under favorable conditions for both systems, and that therefore a larger quantity of food materials is obtained by filling the corn crop into a silo than by any other method of preserving it known at the present time.

What has been said in the foregoing in regard to fodder corn applies equally well to other crops put into the silo. A few words will suffice in regard to two of these, clover and alfalfa. Only a few accurate siloing experiments have been conducted with clover, but enough has been done to show that the necessary losses in siloing this crop do not much, if any, exceed those of Indian corn. Lawes and Gilbert, of the Rothmasted Experiment Station, England, placed 264,318 pounds of first and second crop clover into one of these stone silos, and took out 194,470 pounds of good clover silage. Loss in weight, 24.9 per cent. This loss fell, however, largely on the water in the clover. The loss of dry matter amounted to only 5.1 per cent., very nearly the same amount of loss as that which the same experimenter found had taken place in a large rick of about forty tons of hay, after standing for two years. The loss of protein in the silo amounted to 8.2 per cent. In another silo 184,959 pounds of second-crop grass and second-crop clover were put in, and 170,941 pounds were taken out. Loss in gross weight, 7.6 per cent; loss of dry matter, 9.7 per cent.; of crude protein, 7.8 per cent.

In a siloing experiment with clover, conducted at the Wisconsin Station, on a smaller scale, Mr. F. G. Short obtained the following results: Clover put into the silo, 12,279 pounds; silage taken out, 9,283 pounds; loss, 24.4 per cent.; loss of dry matter, 15.4 per cent.; of protein, 12.7 per cent.

There is nothing in any of these figures to argue against the siloing of green clover as an economical prac

tice. On the other hand, we conclude that this method of preserving the clover crop is highly valuable, and, in most cases, to be preferred to making hay of the crop.

No extended investigation has been made as to the losses sustained in the siloing of alfalfa, but there can be little doubt but that they are considerably smaller than in making alfalfa hay, if proper precautions guarding against unnecessary losses in the silo are taken. According to the testimony of Professor Headden of the Colorado Experiment Station, the minimum loss from the falling off of leaves and stems in successful alfalfa hay making amounts to from 15 to 20 per cent., and in cases where the conditions have been unfavorable, to as much as 60 and even 66 per cent. of the hay crop. Aside from the losses sustained through abrasion, rain storms, when these occur, may reduce the value of the hay one-half. The losses from either of these sources are avoided in preserving the crop in the silo, and in their place a small loss through fermentation occurs, under ordinary favorable conditions, amounting to about 10 per cent. or less.

There is this further advantage to be considered when the question of relative losses in the silo and in hay-making or field-curing green forage, that hay or corn fodder, whether in shocks or in the field or stored under shelter, gets poorer and poorer the longer it is kept, as the processes of decomposition are going on all the time; in the silo, on the other hand, the loss in food substances is not appreciably larger six months after the silo was filled than it is one month after, because the air is shut out, so that the farmer who puts up a lot of fodder corn for silage in the fall can have as much and as valuable feed for his stock in the spring, or in fact, the following summer or fall, as he would have if he proceeded to feed out all the silage at once.

"Generally speaking, 3 tons of silage are equal in feeding value to one ton of hay. On this basis a much larger amount of digestible food can be secured from an acre of silage corn than from an acre of hay. The food

equivalent of 4 tons of hay per acre can easily be produced on an acre of land planted to corn."—(Plumb.)

3. **Succulence.** Succulent food is Nature's food. We all know the difference between a juicy, ripe apple and the green dried fruit. In the drying of fruit as well as of green fodder water is the main component taken away; with it, however, go certain flavoring matters that do not weigh much in the chemist's balance, but are of the greatest importance in rendering the food material palatable. It is these same flavoring substances which are washed out of the hay with heavy rains, and renders such hay of inferior value, often no better than so much straw, not because it does not contain nearly as much food substances, like protein, fat, starch, sugar, etc. (see Glossary), but because of the substances that render hay palatable having been largely removed by the rain.

The influence of well-preserved silage on the digestion and general health of animals is very beneficial, according to the unanimous testimony of good authorities. It is a mild laxative, and acts in this way very similarly to green fodders. The good accounts reported of the prevention of milk fever by the feeding of silage are explained by the laxative influence of the feed.

4. **Uniformity.** The silo furnishes a feed of uniform quality, and always near at hand, available at any time during the whole year or winter. No need of fighting the elements, or wading through snow or mud to haul it from the field; once in the silo the hard work is over, and the farmer can rest easy as to the supply of succulent roughage for his stock during the winter. An ample supply of succulent feed is of advantage to all classes of animals, but perhaps particularly so in case of dairy cows and sheep, since these animals are especially sensitive to sudden changes in the feed. Also, stock raisers value silage highly on this account, for silage is of special value for feeding preparatory to turning cattle on to the watery pasture grass in the spring. The loss in the weight of cattle on being let out on pasture in spring, is often so

great that it takes them a couple of weeks to get back where they were when turned out. When let out in the spring, steers will be apt to lose weight, no matter whether silage or dry feed has been fed, unless they are fed some grain during the first week or two after they are turned out. For more detailed information regarding the feeding of silage for beef production, see chapter 3, page 28.

5. **Economy of Storage.** Less room is required for the storage in a silo of the product from an acre of land than in cured condition in a barn. A ton of hay stored in the mow will fill a space of at least 400 cubic feet; a ton of silage, a space of about 50 cubic feet. Considering the dry matter contained in both feeds we have found that 8,000 pounds of silage contains about as much dry matter as 2,323 pounds of hay, or 160 against 465 cubic feet, that is, it takes nearly three times as much room to store the same quantity of food materials in hay as in silage. In case of field-cured fodder corn, the comparison comes out still more in favor of the silo, on account of the greater difficulty in preserving the thick cornstalks from heating when placed under shelter. According to Professor Alvord, an acre of corn, field-cured, stored in the most compact manner possible, will occupy a space ten times as great as in the form of silage. While hay will contain about 86 per cent. of dry matter, cured fodder corn often does not contain more than 60 and sometimes only 50 per cent. of dry matter; the quantities of food material in fodder corn that can be stored in a given space are, therefore, greatly smaller than in case of hay, and consequently, still smaller than in case of silage.

Since smaller barns may be built when silage is fed, there is less danger of fire, thus decreasing the cost of insurance.

6. **No Danger of Rain.** Rainy weather is a disadvantage in filling silos as in most other farm operations, but when the silo is once filled, the fodder is safe, and the farmer is independent of the weather throughout the season.

If the corn has suffered from drought and heat during the fall months, it is quite essential to wet the corn either as it goes into the silo, or when this has all been filled, in order to secure a good quality of silage; and unless the corn is very green when it goes into the silo, the addition of water, or water on the corn from rain or dew, will do no harm. If the corn is too dry when put into the silo, the result will be dry mold, which is prevented by the addition of the water, which replaces that which has dried out previous to filling if this has been delayed.

A common practice among successful siloists is to fill the silo when the lower leaves of the standing corn have dried up about half way to the ears. Generally, the corn will be in about the proper condition at that time, and there will still be moisture enough left in the plants so that the silage will come out in first-class condition.

There must be moisture enough in the corn at time of filling the silo, so that the heating processes, which take place soon after, and which expel a considerable portion of the moisture, can take place, and still leave the corn moist after cooling, when the silage will remain in practically a uniform condition for several years if left undisturbed. But if, on account of over-ripeness, frosts, or excessive drought, the corn is drier than stated, it should be made quite wet as stated above, and there is little danger of getting it too wet. The writer has filled silo with husked corn fodder about Christmas, and as the fodder was thoroughly dried, a $\frac{3}{4}$ -inch pipe was connected with an overhead tank in the barn and arranged to discharge into the carrier of the cutter as the cutting took place, a No. 18 Ohio cutter being used for that purpose. Although the full stream was discharged, and with considerable force, on account of the elevation of the tank, and the cut fodder in the silo still further wet on top with a long hose attached to a wind force pump, it was found, on opening the silo a month later, that none too much water had been used; the fodder silage came out in good condition, was eaten greedily by the milch cows, and

was much more valuable than if it had been fed dry from the field.

Where haymaking is precluded, as is sometimes the case with second-crop clover, rowen, etc., on account of rainy weather late in the season the silo will furthermore preserve the crop, so that the farmer may derive full benefit from it in feeding it to his stock. Frosted corn can also be preserved in the silo, and will come out a very fair quality of silage if well watered as referred to above.

7. No danger of Late Summer Droughts. By using the silo with clover or other green summer crops, early in the season, a valuable succulent feed will be at hand at a time when pasture in most regions is apt to give out; then again, the silo may be filled with corn when this is in the roasting-ear stage, and the land thus entirely cleared earlier than when the corn is left to mature and the corn fodder shocked on the land, making it possible to finish fall plowing sooner and to seed the land down to grass or winter grain.

8. Food from Thistles. Crops unfit for haymaking may be preserved in the silo and changed into a palatable food. This is not of the importance in this land of plenty of ours that it is, or occasionally has been elsewhere. Under silage crops are included a number of crops which could not be used as cattle food in any other form than this, as ferns, thistles, all kinds of weeds, etc. In case of fodder famine the silo may thus help the farmer to carry his cattle through the winter.

9. Value in Intensive Farming. More cattle can be kept on a certain area of land when silage is fed, than is otherwise the case. The silo in this respect furnishes a similar advantage over field-curing fodders, as does the soiling system over that of pasturing cattle; in both the siloing and soiling system there is no waste of feed, all food grown on the land being utilized for the feeding of farm animals, except a small unavoidable loss in case of

the siloing system incurred by the fermentation processes taking place in the silo.

Pasturing cattle is an expensive method of feeding, as far as the use of the land goes, and can only be practiced to advantage where this is cheap. As the land increases in value, more stock must be kept on the same area in order to correspondingly increase the profits from the land. The silo here comes in as a material aid, and by its adoption, either alone or in connection with the siloing system, it will be possible to keep at least twice the number of animals on the land that can be done under the more primitive system of pasturing and feeding dry feeds during the winter. The experience of Goffart, "the Father of Modern Silage," on this point is characteristic. On his farm of less than eighty-six acres at Burtin, France, he kept a herd of sixty cattle, besides fattening a number of steers during the winter, and eye-witnesses assure us that he had ample feed on hand to keep one hundred head of cattle the year around.

We might go on and enumerate many other points in which the siloing process has decidedly the advantage over the method of field-curing fodder or haymaking; but it is hardly necessary. The points given in the preceding will convince any person open to conviction, of the superiority of the silo on stock or dairy farms. As we proceed with our discussion we shall have occasion to refer to several points in favor of silage as compared with dry feed, which have not already been touched upon. We shall now, first of all, however, discuss the Summer Silo; also the wonderful progress of the use of silage in beef production, and of its help in maintaining soil fertility. Afterwards, we will proceed to explain the method of building Silos and then discuss the subject of making and feeding silage.

CHAPTER II.

THE SUMMER SILO.

The summer silo is fast becoming popular and even necessary because of its splendid aid in supplementing summer pastures and tiding the herd over the period of drouth, heat and flies. Experiment Stations that have studied the subject, strongly advocate its use and some of the leading agricultural papers have been speaking in no uncertain voice as to its advantages.

"The summer silo is as certain to assert its value as American agriculture is certain to go forward rather than backward," says Breeder's Gazette of Chicago. "Pasture as at present used—or abused—is a broken reed. An over-grazed acre is the costliest acre that the farmer supports. Even in normal seasons grass rests in the summer time, and unless a fall and winter pasture is laid by, little good is derived from grass lands after the flush of spring. The silo supplements pastures, and carries the burden of the winter's feeding."

Following the same line of thought Purdue Experiment Station Bulletin No. 13 says:

"Too much dependence is usually placed upon pasture for summer feeding. Pasturing high priced land is unprofitable in these times. Few stop to consider the destructive effects of trampling, that, while a cow is taking one bite of grass, she is perhaps soiling or trampling the life out of four others. If sufficient silage is put up each year part can well be used for summer feeding, which will be found less laborious than the daily hauling of green crops for the herd. The herd must not be allowed to shrink in flow unduly, as it is practically impossible to bring them back during the same lactation. The young stock, destined for future producers, must not be neglected on short pasture, for the labor and expense of

supplying their needs as above indicated for the herd, is insignificant compared with the importance of their unimpaired growth."

There are many intelligent farmers who are providing a succession of fresh soiling crops and using them to great advantage in helping out short pastures. "But," says Professor Frazer of the Illinois Station, "there is necessarily much labor attached to preparing the ground, planting, raising, and harvesting the common crops used for this purpose. There is usually much loss in being obliged to feed these crops before they are mature and after they are overripe. And for the farmer who can make the larger investment, the most practical way of all to provide green feed for summer drouth is to fill a small silo with corn silage. It not only saves the labor and inconvenience in the putting in and cultivation of small patches of different kinds of crops, but also in harvesting from day to day in a busy season of the year.

"These soiling crops can be dispensed with and all the feed raised from one planting in one field in the shape of corn. The whole field of corn for the silo may be cut at just the right stage of maturity when the most nutriment can be secured in the best possible condition of feeding. It also avoids the possibility of the soiling crops failing to ripen at the exact period when the drouth happens to strike the pasture. For the silo may be opened whenever the pasture fails, regardless of the date, and the silage will remain in the best condition as long as needed. When the pasture supplies enough feed again, what is left in the silo may be covered over and thus preserved without waste, and added to when refilling the silo for winter use."

Further evidence comes from the Purdue Station. Prof. Skinner writes:

"Many successful farmers with limited areas of pasture make a practice of filling a small silo for summer use. It has been well established that silage properly stored in a good silo when the corn or other crop is in the most de-

sirable condition, will keep in good condition for several years. Many foresighted men taking advantage of this fact plan to have silage on hand the year around. They are thus prepared for any unusual conditions such as drouth, scant pasture, excessively long winters, and it is altogether practical and profitable. It is desirable to have a silo of relatively small diameter for summer feeding as it is necessary to feed considerable amount from off the top of the silage each day in order to keep it from moulding during the hot, damp weather.

There are three silos on the university farm and it is our aim to avoid having all these empty at the same time. A limited farm, greatly overstocked, makes it necessary to supplement the pastures every year, and while soiling crops are grown in abundance they cannot be relied upon because of the gravelly nature of the sub-soil underlying the farm, which means longer or shorter periods of drouth annually.

It would be absolutely impossible to maintain the number of animals on the college farm that we are successfully carrying without the silage to supplement our pastures and soiling crops. Many Indiana men have come to look on the silo as quite as important in supplementing the pastures as it is in furnishing succulence during the winter season."

The dry pastures and burned-up hillsides following the drouth of 1910 made a very strong impression as to the importance of having good summer feeding. It was an eloquent though severe plea for the summer silo and led to some splendid testimony in its favor. The drouth "cut down the milk flow in most of the herds nearly 50 per cent. Not one farmer in a hundred had provided for this emergency by a good supply of succulent food that would make milk. It is the same old story over again. It seems to take a tremendous lot of pounding on the part of Providence, to get it into farmers' heads that a summer silo is a grand thing. The Hoard's Dairyman herd of cows had 50 tons or more of nice corn ensilage to turn to when feed grew short and they have rolled out the milk nicely right along. Besides, they will keep at it. There is nothing like a supply of ensilage for summer use. It is close by and handy to the stable for use, when you want it.

And furthermore it will produce more milk than any other kind of soiling feed."

This is the experience of Wisconsin experimenters, who find that silage holds milk-flow during drouth even better than soiling. It is rational that it should.

The substance of a strong editorial in Wallace's Farmer, while referring particularly to the lesson of the 1910 drouth, applies with equal force wherever pasture is used or cattle are fed. It is worth quoting here:

"The question we are constantly asked is: 'Will silage keep through the summer?' We are glad to be able to give a direct answer to this, not theoretically, but from personal experience. We built a silo on one of the Wallace farms and filled it in 1908, and made the mistake of building it too large. During the winter of 1908-9 the silage was not all used. Last fall we put in new silage on top of the old, and during the winter used out of the new silage, leaving the unused remainder in the bottom. We are now feeding that silage, and the man in charge, an experienced dairyman, tells us that after the waste on top was removed, this two-year-old silage is as good as any he ever used; that the cattle eat it as readily as anything and eat more of it than they did during the winter.

"This is in entire harmony with every farmer we ever heard of who uses summer silage. If silage will keep two years without any waste except on the exposed portion of the surface, then it will certainly keep one.

"Some people say: 'We may not have another summer like this.' To this we reply that a period of short pastures during July and August is the rule in all the corn belt states, and lush grass at this season of the year is a rare exception. Remember that seasons come in cycles of unknown duration, and the time of their coming is uncertain; that it always has been so, and it is safe to assume that they always will until the Creator sees fit to change his method of watering the earth. Therefore, well-made silage in a good silo is just as staple as old wheat in the mill. There will be a waste of several inches on the surface, just as there is waste of several inches on the surface of the hay stack or shock of corn fodder; but a man can afford that waste, if he has the assurance that his cows will not fail in their milk or his cattle lose flesh, even if there should be little or no rain for thirty or sixty days. When you put up a silo for summer use, you are going

into a perfectly safe proposition, provided, of course, you build it right, and fill it properly."

It is well to remember that less silage will naturally be fed in summer than in winter and in order to keep the surface in fairly good condition, at least three inches of silage should be taken off daily, where two inches suffice in the winter. It will be found advisable therefore in building the summer silo to keep the diameter proportionately smaller.

CHAPTER III.

THE USE OF SILAGE IN BEEF PRODUCTION.

In his "Feeds and Feeding," published some years ago, Prof. Henry says in one paragraph, with regard to feeding silage to beef cattle:

"Because of its succulence and palatability, this forage is recommended as a substitute for roots for fattening cattle." In another paragraph:

"If the stockman desires a cheap, succulent feed for his cattle in the winter time, he will find it in corn silage. The same quantity of nutriment that a root crop yields can be produced more economically in corn forage stored in the shape of silage, and this article can be fed with satisfaction to steers during the early stages of fattening. At first as much as forty or fifty pounds of silage may be given daily to each steer; when the full grain feeding period arrives, let the allowance be cut down to 25 or 30 pounds per day. A limited use of this feed will keep the system cool and the appetite vigorous."

The same writer is also authority for the statement that the best and most economical way to prevent the "burning out" of steers being well fattened on corn, was to feed ensilage with the corn.

Accumulating experience in many parts of the country covering a number of years indicates that Prof. Henry was right, and it strongly approves the use of silage in maintaining beef herds and in fattening steers. In the minds of many farmers, the dairyman has long held a monopoly on the profitable use of this succulent food, and it is true that in cheapening production of dairy products and in maintaining the milk flow and the perfect condition of his cows in those months when fresh grass is not to be had for them, the silage system has reached its highest development. Each year, however, has seen a

steady growth of sentiment in progressive stock-raising communities favorable to a more profitable use of corn fodder, and today many of the most prominent beef cattle breeders and feeders are among the foremost users of silage for feeding purposes.

It is no secret that a prejudice has existed against silage in feeding circles. But the astonishing results achieved by every doubter who tried the experiment is "fact-evidence" of the most weighty nature and is serving as a strong weapon against such prejudice.

One of the biggest and most substantial silos in Iowa was erected in the fall of 1910 in Cherokee County, near Quimby, in the northwestern part of the state. It is fifty feet high, twenty-six feet across and will hold approximately 500 tons of silage. It is built of cement blocks and was erected for **steer feeding purposes exclusively.**

Many Experiment Stations have for some time been carrying on experiments to show the comparative value of silage and other feeds, and these have very generally resulted with credit to corn silage, as an economical and suitable feed for steers.

Prof. Herbert W. Mumford of the Illinois College of Agriculture, Urbana, in a recent article calls attention to the increasing interest in corn silage in connection with the feeding of beef cattle. The silo is today an essential feature in the successful dairyman's equipment but its adoption by cattle feeders has been noticeably slower. Mr. Mumford says that "This is undoubtedly partly due to the fact that dairying more naturally lends itself to intensive methods while beef production has been more universally profitable when pursued in a large way by more or less extensive systems of farming. It is possible, too, that the cattle feeder has expected too much of silage and has confined the cattle too largely upon it. It is growing in favor among the beef producers and we confidently believe that it has a large place in the cattle feeding of the future in the corn belt.

It furnishes the best means of storing the entire corn crop, a part of which is now only partially utilized in the corn belt, with minimum waste. Experiment stations have been gradually but surely teaching us its usefulness in the feeding of beef cattle. Practical feeders here and there have been carefully trying it out, and with but very few exceptions where the beef producer has erected a silo, filled it with corn and fed it out to his beef cattle he has become a silage-for-beef-cattle convert.

Silage is undoubtedly of especial value in the feeding of beef breeding cows and in the wintering of calves and young cattle intended for beef production. The Illinois experiment station has determined the economic importance of the silo in beef production in the state when used in connection with the feeding of beef cows and young cattle. This importance might be briefly stated as follows:

“Corn silage when supplemented with oats and hay, used for wintering calves intended for beef production, will produce thirty-five pounds more gain per steer during the season at the same cost of ration than when shock corn similarly supplemented is fed. This extra gain is worth 5 cents per pound, or \$1.75 per calf. There are over 700,000 calves wintered in Illinois each year.

“It should be borne in mind that the cattle feeders who are apparently succeeding best with silage are those who buy young, light-weight feeders weighing from 600 to 1,000 pounds, feeding them silage in largest amounts at the beginning of the fattening period, providing abundant shelter, and that in most instances the silage is withdrawn from the ration several weeks before the cattle are finished, and who do not depend upon silage exclusively. Several practical feeders have expressed the opinion that the main utility of silage is to prepare cattle for heavy feeding by putting them in condition to feed well; that as an appetizer and a laxative it has great value in starting cattle on feed.”

The investigations of the Ohio and Indiana Stations

regarding the use of corn silage for fattening beef cattle, indicate that it can be used to good advantage, when stover and hay are high in price. The Farmer's Guide of Indianapolis thus comments on the matter:

"Forty-two head of steers, most of them grade Short-horns, were used in an experiment in which 25 pounds of silage per steer was fed daily. The ration which included the silage gave almost exactly the same rate of gain as did the dry ration.

"No difference in the finish of the two sets of cattle was apparent. This was shown by the fact that although when the cattle were at market, one pen contained only silage-fed cattle and another only dry-fed cattle. A buyer of wide experience, without knowing how the cattle had been fed, purchased both lots at the same price. Other expert cattlemen failed to note any difference between the two lots.

"It is not to be expected that silage alone or silage and other rough feed will produce a high finish in a short feeding period, since not enough grain is present in the silage for this purpose. Less shelled corn, however, was required by the steers that received silage than by the ones that received only dry feed.

"The results obtained by the Ohio station with the feeding of silage to beef cattle are similar to the experience of the Indiana station, where it was found that silage added to the feeding ration was an advantage in the way of providing succulence. Several practical feeders have made a marked success with this feed and do not hesitate to recommend it. In fact, one Ohio man has several large silos, which he fills annually especially for feeding his beef cattle.

"When it is figured that all the feeding value of the corn plant is preserved in the form of silage; that there is an immense saving in storage space; that it is easier handled in feeding, and that all animals eat it with a relish, it seems that the farmer might, with advantage, give silage a little more consideration. A silo, well filled will provide plenty of succulent, nutritious feed for live stock during that period of the year when pastures are short and during the winter months when green feed is unobtainable."

The Indiana Experiment Station reports the results of a six months' feeding trial, wherein "one lot of steers was

fed a ration of shelled corn, cotton seed meal and a full ration of corn silage. A second was fed a ration of shelled corn, cotton seed meal, some hay and about one-half a full ration of corn silage, while a third lot was fed all the corn and clover they would eat. Corn was valued at 60 cents a bushel, cotton seed meal at \$27 per ton, clover hay at \$8 per ton, and corn silage at \$3 per ton. At the beginning of the experiment the lots did not vary more than 25 pounds in total weight and all steers were purchased at the same price per hundred-weight. There were ten steers in each lot, and hogs followed each lot to consume feed left in the droppings.

The experiment opened Nov. 18, 1908, and closed May 17, 1909. During this period of six months the first lot gained 4,658.3 pounds, or an average of 2.58 pounds per day; the second, 4,211.6 pounds, or 2.33 pounds per day; the third, 3,416.6, or 1.89 pounds per day. The lot receiving the full silage ration, therefore, gained more than a half pound more per day than the lot receiving no silage, while that receiving half a full silage ration gained somewhat less than half a pound more also than the lot receiving no silage.

The cost of a pound of gain for the full silage fed lot was \$9.79; for the lot having a half silage ration, \$11.35, and for the clover and corn fed lot, \$12.99. In the same order the first lot sold at \$7.25 per hundredweight, or 99 cents higher than was necessary to sustain neither loss nor gain on the proposition. The second sold at \$7.15, or 54 cents more than was necessary to sustain no loss, and the third at \$6.90, or only 15 cents above the cost. The pork produced behind the first lot netted \$107.23, behind the second \$124.61, and the third, \$97.68. The net profit resulting from feeding the ten steers receiving a full silage ration, shelled corn and cotton seed meal, was \$24.04 per head, including the profit from the pork produced, that of the ten steers fed a half silage ration, some hay and shelled corn and cotton seed meal, \$19.71 per head, and those receiving clover and shelled corn only, \$12.64 per head, both

also including profit on the pork. The first lot, therefore, appears at an advantage of \$11.33 per steer over the lot receiving no silage, while the second lot also appears at an advantage of \$7.07 per steer over this lot. Judging from these results, the silo is a paying investment to the beef feeder. The difference in net profit from feeding these 30 steers the full silage ration and the corn and clover ration alone, would amount to \$339.90 in favor of the full silage ration."

Indiana and Ohio seem to have set the pace for feeding silage to beef cattle, and an increasingly large number of silos is being erected as a result of the stimulus given to this kind of feeding. The Breeder's Gazette of Chicago says:

"Indiana feeders who have demonstrated to their own satisfaction that silage is valuable for beef production are expanding their operations this season, and have been liberal buyers at Chicago, Omaha and Kansas City. Southern Michigan will feed an unusually large number of cattle, owing to scarcity of lambs. Illinois has been a heavy purchaser both at Kansas City and Omaha, and Chicago could have sent five good feeding steers into nearby territory where one has been available.

"Continued high prices have encouraged cattle feeding in sections where, according to confident prophecy, the industry was on the wane."

Quoting again from an agricultural publication:

"The Kansas stations report that steers fed a ration with silage made better gains, and excelled those without silage as prime beef. The Ontario Agricultural College reports that more rapid gains and cheaper gains were made on grain and silage than on grain and hay or grain and roots.

"From results it appears that cattle receiving silage as their sole roughness during the winter, made the largest average gains, did not drift materially when turned on grass after the first ten days, slaughtered out to better advantage than dry-fed cattle, and were in a thriftier and better condition throughout the entire feeding period. This would go to show that succulent foods can be fed to cattle maintained as stockers and finished on grass. Larger returns can be got from feeding silage to cattle than from

grazing them. This is only natural when we consider that an acre of corn yielding eight tons of silage will keep four cows 180 days, while an acre of pasture will keep only one cow that long."

It is a mistake for the feeder to regard either silage or hay as a satisfactory substitute for the other, to the extent of entirely replacing one with the other. Says Mr. C. F. Curtiss of the Iowa Experiment Station:

"The chief cause of complaint in the use of silage arises from the fact that it is too often regarded as a complete ration. The use of silage does not dispense with the use of grain, except in case of very moderate feeding for maintenance, without much reference to grain. Where good corn silage is used it may usually be substituted for about two-thirds the hay and about one-third the grain that would be used in full feeding, without the silage.

"Clover hay is well adapted to supplement silage to correct the excessive acidity of heavy silage feeding and also to furnish the protein nutrients in which silage is lacking. It should not be left out of the ration when feeding silage."

Prof. Plumb of the Ohio Agricultural College has this to say on the subject:

"If silage is fed under cover, and to cattle not wallowing in mud or oozy manure, then good results will generally come from its use. However, hay or other dry roughage should also be fed. Silage fed twice a day and hay once should give good results. When cattle are being finished for shipment, then the amount of silage fed should be reduced and the dry roughage increased, this to prevent much shrinkage in shipping. However, in what is known as rational feeding, but little shrinkage is apt to occur from the use of the silage. In experiments with steers fed different rations at the Virginia station, those fed silage showed no appreciable shrinkage in the market over those fed exclusively dry feed.

"In feeding experiments conducted at the Missouri station in 1906-7 with steers weighing about 800 pounds each at the beginning, those fed silage ate less dry matter than those fed whole stover or shredded stover and gained in weight, while the dry stover lots lost. The same sort of results were also secured from feeding siloed stover compared with air-dried material."

One of the largest feeders of beef cattle in the East, Hon. Humphrey Jones, scored a center shot for "silage-for-beef" when he remarked:

"We carry upon the same land more than fifty per cent. more cattle than we did before we had the silos, and whatever the correct theory of the matter may be, this solid hard fact is sufficient to satisfy us that very much more can be got out of the corn plant fed in the form of silage than when fed dry in any manner which is practicable with us."

Mr Jones has large stock farms at Washington C. H., Ohio. He is a heavy feeder of steers—feeds from 500 to 1,000 annually—and he makes ensilage a very large factor in the ration. He speaks therefore from the standpoint of practical experience, and being a thorough business farmer, his statements can be relied upon as accurate. On this subject Mr. Jones says:

"We have found in the experience of feeding all kinds of cattle, from calves to three-year-olds, that we can get as good gains from feeding ensilage as in any other method of feeding that we were ever familiar with. We add to our silage, of course, clover hay or alfalfa. We grow large quantities of these. During most of the time we have added to our corn soy beans cut in with it, because they are very rich in protein. In addition to that we have fed cottonseed meal with the silage, and it is an ideal way to feed it, because cottonseed meal is a thing by which cattle may be injured if it is not properly fed. When sprinkled over the ensilage it is mingled with all that mass of roughage, and you can feed from three to five pounds of cotton seed meal for six months to cattle without any serious effects at all. We advise starting with about two pounds of cottonseed meal, and increasing up toward the end of the period to about five pounds; and with that, without the addition of a grain of corn, we have been able to make gains as rapidly and put the cattle in better finish than we were ever able to do in any other way.

"Fifty bushels of corn to the acre will make about ten tons of ensilage as it comes from the field, and about eight tons as it comes out of the silo. There is a weight of about 3,000 pounds of corn in that, which you see is about 20 per cent. of the total weight as fed to the cattle;

and the steer will eat about fifty pounds a day, which contains ten pounds of corn; and he is getting it in a form that he digests and utilizes every pound. If you add to that two to five pounds of cottonseed meal, all our information upon that matter is that it has a feeding value of about two and one-half times shelled corn; so that if you give a steer five pounds of cottonseed meal, he is getting an equivalent of ten pounds or more of corn, in addition to the ten pounds of actual corn fed in the ensilage. If he digests and utilizes every pound of the twenty pounds of corn, either in the form of cottonseed meal or shelled corn, he will do well, if he has all the good roughage he wants. In addition to that, this ensilage puts him in the shape that he is when he is on grass. It is a succulent, cooling food, that keeps his hair in the same condition as when he is on grass, and it finishes him up evenly. Our experience has been that they finish up more uniformly on the ensilage than on dry feed. These gains, as you can see, if they are made as rapidly on the ensilage, hay, and cottonseed meal as they can be made in any other way, must be made much more economically, because you are utilizing there the stalk and the leaves and the husks of the corn plant, which, as I have said, counting the corn worth 40 cents a bushel, and fifty bushels to the acre, is worth two-fifths as much as the ears; so you are feeding about \$12 or \$13 worth that you are wasting in the ordinary way of feeding.

“Briefly, therefore, it is our experience that the feeding of ensilage to cattle is valuable. It has long been recognized as an indispensable in the dairy, and I could never understand why, if it was good to put fat in the milk pail, it would not be good to put fat on the back. There is essentially no difference in the process that takes place in the digestive tract.”

Speaking of the feeding value of corn when put in the silo, Mr. Jones continues:

“The putting of the corn in the silo is not going to increase the feeding value of it a particle, but it will render the grains more digestible. The food in a large silo is always so hot that you can't hold your hand in it, through the process of fermentation; and it therefore puts the grain in condition so that it is more easily and completely digested. But with a practical feeder of cattle that is not a very material thing. It does not matter if the cattle do waste a great deal of the corn; he has the hogs to

gather it up. So there is no increased value in the grain by putting it in the silo, notwithstanding the fact that the steer will digest a larger per cent. of it. The only place that the benefit or gain comes in is through getting the full value of the stalks. You do get every pound of that, because the steer will eat it up completely. Our experience covering a period of eight years is that the figure of 40 per cent. value in the stalks is not too high; in fact, I think it is low. Practically, I believe, the feeding value of corn by putting it in a silo is doubled. We have been able to carry twice as many cattle as we could before.

With three-fourths of the feeders in the principal cattle-feeding sections of Ohio, shock corn only is fed and the corn stands out in the field all winter and is hauled to the feed lot as needed. Many shocks twist down and partially or wholly rot, all are soaked with the rains and beaten by the winds, get hard and woody, and are thus more or less damaged. It is a matter of common knowledge among feeders that after the first of March the fodder in shock corn is of little value. Under favorable conditions, fattening cattle will eat only the best portions of the fodder, and the great bulk of it is wasted and thrown out to keep them up out of the mud. With all these things taken into consideration the gain in feed value to the average cattle feeder who uses shock corn, by reason of siloing the corn is, in our judgment, not less than fifty per cent."

Silage-fed Beef Cattle in the South.

After exhaustive experiments conducted at the Virginia Station, Prof. Andrew M. Soule concludes that the results obtained illustrate the value of silage as a maintenance food for winter feeding, whether the animals are to be slaughtered immediately or carried over and grazed during the summer; also, that silage can be used most advantageously by stockmen in the South and that its utilization would confer many advantages which are not now enjoyed and would add very much to the profits secured from the winter feeding of beef animals, no matter what disposition is to be made of them. He adds that the character of the silage has much to do with its efficiency as a food stuff, and the skill and intelligence displayed

in combining it with suitable companion foods exercise a determining influence on the results obtained under a given set of conditions. The vast importance of silage as an economic factor in the production of beef in the South is clearly demonstrated by the results set forth in the test in question.

"The test of 1906-7 covered a period of 149 days, during which time the average ration consumed was between 8 and 9 pounds of concentrates, from 35 to 39 pounds of silage and about 2 pounds of dry stover or hay. It was found advisable to feed the small amount of dry food indicated to overcome the laxative tendencies of the silage, but it was surprising to find what a very small amount of dry food accomplished this end.

Waste of Roughness.

"As in previous tests, there was no silage wasted. The percentage of roughness wasted in the form of stover varied from 30.1 to 44.1 per cent. of the total amount fed. With the hay this varied from 1.7 to 4.5 per cent. For some reason some of the groups did not eat the hay nearly as well as the others. These results would indicate, roughly speaking, that from 3 to 4 per cent. of the hay ordinarily fed would be wasted, and at least one-third of the stover. These figures but emphasize again the great advantage of silage, which owing to its ease of mastication, palatability and pleasant aroma, when properly made, provides a most inviting form of roughness for cattle.

Shrinking of Silage-fed Cattle.

"It has generally been said that cattle fed on silage as the principal roughness would lose very materially in live weight when shipped long distances. The cattle in this test were shipped to Jersey City under the usual conditions, the shrinkage per group varying from 197 to 213 pounds. There was little to choose between the groups in the actual loss observed. The actual loss per individual amounted to only 41.2 pounds, which is a comparatively

slight shrinkage with any lot of cattle shipped such a long distance. In fact, practical shippers and handlers in this State figure the average shrinkage to Jersey City at from 60 to 76 pounds.

“There does not seem to be any justification, therefore, for claiming that silage fed cattle will drift more than cattle fed in other ways. When these cattle were sent to Jersey City a representative of the Station who accompanied them found the buyers much prejudiced against cattle from the South, stating that they did not kill out well, and that the meat was of a dark color, and the bone very hard. Though these cattle presented as good an appearance as many of the corn fed animals shipped from the West and on sale at the same time, the buyers persisted in discriminating against them because of the belief that silage fed cattle would not kill out advantageously or make a first-class quality of beef. The cattle followed through the slaughter pens, however, killed out as well and better in many instances than the corn fed cattle from the West, and the meat was of superior quality, the fat and lean being better blended, and the color particularly good. This lot of cattle dressed out 56.9 per cent., which is very creditable, considering that they were ordinary grade, and fed but 150 days on a ration which has been regarded as eminently unsatisfactory for feeding beef cattle to a finish. These figures seem to amply justify the claim that silage is a most satisfactory roughness for beef cattle, and that animals fed on it will ship well, kill well and produce meat of fine quality. And these conclusions seem justified even in the face of competition with western corn fed cattle.

“The efficiency of silage as a valuable food for Southern stockmen when fed under the conditions prevailing in this test needs no further vindication in the light of the facts here set forth, and should do much to encourage the production of beef in sections where the natural conditions by reason of the insufficiency of grass are supposed to be a barrier to this phase of animal industry.

. Silage Good for Stockers.

“Experiments were also conducted for two years with the object of ascertaining which was the best rations to feed to animals which it is desired to maintain as cheaply as possible and still keep in a growing, vigorous condition throughout the winter. It is naturally essential that the rations be not fattening in nature or the animals will drift much worse when put on grass, but it seems very desirable that some grains should be secured rather than feed the animals very considerable quantities of expensive foods as is now often the case, and have them actually lose in live weight rather than make gains during the winter season. It has generally been held that silage alone could not make a satisfactory winter ration for stockers, and so this point has been carefully investigated in the present experiment. It has generally been held that cattle fed a watery succulent ration in the winter would drift very badly when placed on grass. This matter will be discussed under the appropriate heading, as the results obtained this year are particularly encouraging and in a matter of economy favor silage quite markedly.

Summary Results of 1905-6 and 1906-7.

“In conclusion, a summary of the results of feeding 124 head of cattle is presented. Sixty-eight of these cattle were fed to a finish in the stall, and fifty-six were carried through as stockers and finished on grass. The average of the results obtained with such a large number of cattle should be fairly reliable. The figures for both years correspond quite closely and show straight silage, or silage and grain to be the most economical ration for use with stockers in the winter. Moreover very much larger profits can be secured from handling stockers with the price of foodstuffs as charged in this report than can be anticipated from stall feeding. This does not mean that stall feeding can not be practiced in some sections with advantage

where grass is at a premium or unavailable. It is proper to reiterate that while the cost of finishing in the stall is practically twice as much per pound of gain as on grass that the figures are presented in an unfavorable light to the stall finished cattle. These figures also seem to justify the fact that cattle fed on silage yield a superior quality of beef, do not drift materially when shipped long distances to market, will kill out a good percentage of dressed meat as compared with animals finished in the west on corn. These results also shown that on a margin of \$1.00 and without taking into consideration the value of the manure or the cost of labor, stall feeding can be practiced in many sections advantageously even when the animals are charged the highest market prices for the foodstuffs utilized. On the other hand, cattle handled as stockers will produce a considerable quantity of manure and may be made to consume cheap forms of roughness made on the farm, will make large profits on a margin of 50 cents, and will even make fair profits on a margin of 25 cents when the pasture is charged to them at the rate of \$1.25 per acre.

“These facts are such as to justify us in recommending farmers generally to build silos and utilize silage in their winter feeding operations for practically all classes of cattle as we believe it can be fed to advantage to calves and yearlings and cattle to be finished either in the stall or on grass. The construction of a silo is not a costly operation and it furnishes food for several months in the cheapest and easiest form to handle and convey to live stock. It is palatable, easy of digestion and assimilation and is highly relished by all classes of live stock. It is made from a crop that is more widely cultivated than any other in America and solves the difficult problem of securing satisfactory substitutes for grass in sections where the latter does not thrive well. The results taken all in all justify the high value we have placed on silage, and it is believed that its extensive utilization will result in revolutionizing the animal industries of the South.”

CHAPTER IV.

THE SILAGE SYSTEM HELPS MAINTAIN SOIL FERTILITY.

When the cattle feeders of this country once thoroughly realize that they can profitably feed and raise stock by means of the silage system, the great problem of maintaining and increasing soil fertility will very largely solve itself, and exhausted soils will recuperate of their own accord.

This statement is based on certain fundamental facts, which Farmer's Bulletin No. 180 covers briefly as follows:

“When subjected to proper chemical tests or processes every substance found on our globe, no matter whether it belongs to the mineral, vegetable or animal kingdom, may be reduced to single elements, of which we now know over seventy. Many of these elements occur but rarely, and others are present everywhere in abundance. United mostly in comparatively simple combinations of less than half a dozen each, these elements make up rocks, soils, crops, animals, the atmosphere, water, etc. The crops in their growth take some of the elements from the soil in which they grow and others from the air. Many elements are of no value to crops; a few, viz., 13 or 14, are, on the other hand, absolutely necessary to the growth of plants; if one or more of these essential elements are lacking or present in insufficient quantities in the soil, the plant cannot make a normal growth, no matter in what quantities the others may occur, and the yields obtained will be decreased as a result.”

The problem of the conservation of soil fertility is therefore largely one of maintaining a readily available supply of the essential plant elements in the soil. Most of these elements occur in abundance in all soils, and there are really only about three of them that the farmer need seriously consider—nitrogen, phosphorous and potash.

Every time that a crop is grown it robs the soil of a valuable portion of these elements. A ton of clover hay for instance, takes from the soil \$10.55 worth of fertilizer. One hundred bushels of corn contains 148 pounds of nitrogen, 23 pounds of phosphorous and 71 pounds of potash, worth at present market prices, 15, 12 and 6 cents per pound, respectively, or \$28.72. That much fertilizer is removed with every 100-bushel corn crop. Other crops vary in proportion. It is clear, therefore, that unless these elements are put back into the soil in some way, it will produce steadily declining crops and soon become exhausted or mined out. How to put them back at the least expense is our problem, and it is not alone for the benefit of future generations; it has a vital bearing on our own crop yields.

At the Illinois Experiment Station, an experiment covering 30 years shows the startling effect of continuous crop farming:

“At this station the yield on a typical prairie soil has decreased under continuous corn raising from 70 bushels to the acre to 27 bushels to the acre during this period, while under a system of crop rotation and proper fertilization the yield on a portion of the same field has been increased during the same period to 96 bushels per acre. These yields are not of a certain year, but averages of three-year periods. The 96 bushels was obtained in a three-year rotation in which corn was followed by oats in which clover was sown. The next year clover alone, followed by corn again. Stable manure with commercial fertilizers was applied to the clover ground to be plowed under for corn. The difference in the yields obtained between the rotation system where fertility was applied and the straight corn cropping without fertility was 69 bushels per acre, or over two-and-a-half times that of the system of continuous corn raising. A large proportion of this difference in yield is clear profit, as the actual expense of producing the 96 bushels to the acre was but little more than in growing the 27. If the results of these two yields were figured down to a nicety, and the value

of the land determined by the net income, it would be found that the well farmed acres would be worth an enormous price as compared with a gift of the land that produced the smaller yield."

Barn-yard manure makes splendid fertilizer. It is perhaps the most important for soil improvement. The reason for this is that it supplies nitrogen, phosphorous and potash and the decaying organic matter needed. In feeding oats, corn, wheat or other crops to animals, it is well to know that about three-quarters of the phosphorous and nitrogen and practically all of the potash go through the body and are returned in the solid and liquid manure. It is evident that the value or richness of the manure depends largely on the crops or part of the crops fed to the animals. Leguminous crops are rich in nitrogen and phosphorous. Three and one-half tons of clover will contain as much phosphorous and 40 pounds more nitrogen than 100 bushels of corn, i. e.: 23 pounds phosphorous and 188 pounds nitrogen. Any system of farming where grain is sold and only stalks and straw retained for feed produces manure weak in both nitrogen and phosphorous. These elements are divided in the corn plant on the 100-bushel basis, about as follows:

100 lbs. nitrogen in grain and 48 lbs. in the stalk.

17 lbs. phosphorous in grain and 6 lbs. in the stalk.

19 lbs. potassium in grain and 52 lbs. in the stalk.

In other words, two-thirds of the nitrogen, three-fourths of the phosphorous and one-fourth of the potassium are in the grain or seed and one-third of the nitrogen, one-fourth of the phosphorus and three-fourths of the potassium are in the stalk or straw. In siloing the corn plant the full value of the fertilizer, in both stalk and grain, is obtained in the manure.

The value of manure depends very largely on the way in which it is handled. Over half the value is in the liquid portion.

Experiments were conducted at the Ohio Experiment Station with two lots of steers for six months to ascertain

the loss through seepage. An earth floor was used for one lot and a cement floor for the other lot. Manure was weighed and analyzed at the beginning and end of the experiments and it was found that that produced on the earth floor had lost enough fertilizer through seepage during the experiments to have paid half the cost of cementing the floor.

Losses through weathering and leaching are also common and should be avoided. Experiments at the same station, during 12 years, show that fresh manure produced increase in crop yields over yard manure amounting to about one-fourth of the total value of the manure.

Nitrogen is manure's most valuable element measured by the cost of replacing it in commercial fertilizer. It heats when lying in heaps and the strong ammonia odor, due to the combination of the nitrogen in the manure and the hydrogen of the moisture of the heap, indicates that in time all the nitrogen will escape in the form of ammonia gas. It is said that a ton of manure contains about 10 pounds of nitrogen, worth \$1.50 or \$2.00, so that this loss of nitrogen is a serious one.

An average dairy cow of 1,000 pounds weight, properly fed, will throw off \$13.00 worth of nitrogen and potash a year in her urine. A horse will throw off \$18.00 worth. Urine has a greater fertilizing value than manure, and together they become ideal.

Every farmer can have his own manure factory by keeping live stock. Naturally, the more live stock the farm can keep, the more manure he will have for returning to the soil.

The silo here comes in as a material aid, and with its adoption it is possible to keep at least twice as much live stock on a given area of land. Pasturing cattle is becoming too expensive a method. High priced lands can be used to better advantage by growing the feeding crop and siloing it, without any waste, to be preserved and fed fresh and green the year around. This method, as we have

said, will insure the maximum supply of splendid fertilizing material.

But the silo does more—it converts the farm into a factory as it were—i. e., it will become a creator of a finished or more nearly finished product instead of being the producer of a mere raw material. The effect will be to raise proportionately the price of every commodity offered for sale.

“On the ordinary farm which markets cereal crops only a part is ever sufficiently fertile to return a profit. The other acres must be put by to regain fertility and are so much dead capital while they are made ready for a further effort. Not so with a farm devoted to beef as the market crop. Every acre of it may be seen producing year after year in an increasing ratio, and occasional crops such as potatoes—which while they need a rich soil for their development yet draw but lightly on fertility and are very useful as cleaning crops—will yield bumper profits in cash.”

This statement applies with full force to what is another very desirable attribute of the silo and the silage system—that it will so increase the live stock of the farm that many of the products heretofore sold in a raw state, and which contain, and therefore carry away most of the fertility of the farm, may now be fed at home.

A few examples will best serve to illustrate this statement:

The fertilizing constituents in a ton of clover hay, as above stated, amount nominally to \$10.55. This would mean then that every time the farmer sells a ton of clover hay, he sells \$10.55 worth of fertility. So much fertility has gone from the farm forever. It would most certainly be wise to feed the clover at home as a balance to the silage ration, thereby keeping the fertility on the farm, and making at the same time some finished product, as cream, milk, butter, cheese or beef, the sale of which will not carry away from the farm any great amount of fertility.

The sale of a ton of butter, which is perhaps the best example of a finished or manufactured product from the farm, contains but 27 cents' worth of fertility. Why then is it not the part of wisdom to feed the clover hay, which contains as above noted, \$10.55 in fertility; timothy hay, \$9.05; corn, \$7.72, and oats, \$10.27, and convert the whole into a finished product—butter, which when sold takes but 27 cents in fertility away with it?

CHAPTER V.

HOW TO BUILD A SILO.

Before taking up for consideration the more important type of silo construction, it will be well to explain briefly a few fundamental principles in regard to the building of silos which are common to all types of silo structures. When the farmer understands these principles thoroughly, he will be able to avoid serious mistakes in building his silo and will be less bound by specific directions, that may not always exactly suit his conditions, than would otherwise be the case. What is stated in the following in a few words is in many cases the result of dearly-bought experiences of pioneers in siloing; many points may seem self-evident now, which were not understood or appreciated until mistakes had been made and a full knowledge had been accumulated as to the conditions under which perfect silage can be secured.

General Requirements for Silo Structures.

1. **The silo must be airtight.** We have seen that the process of silage making is largely a series of fermentation processes. Bacteria (small plants or germs, which are found practically everywhere) pass into the silo with the corn or the siloed fodder, and, after a short time, begin to grow and multiply in it, favored by the presence of air and an abundance of feed materials in the fodder. The more air at the disposal of the bacteria, the further the fermentation process will progress. If a supply of air is admitted to the silo from the outside, the bacteria will have a chance to continue to grow, and more fodder will therefore be wasted. If a large amount of air be admitted, as is usually the case with the top

layer of silage, the fermentation process will be more far-reaching than is usually the case in the lower layers of the silo. Putriferous bacteria will then continue the work of the acid-bacteria, and the result will be rotten silage. If no further supply of air is at hand, except what remains in the interstices between the siloed fodder, the bacteria will gradually die out, or only such forms will survive as are able to grow in the absence of air.

Another view of the cause of the changes occurring in siloed fodder has been put forward lately, viz., that these are due not to bacteria, but to "intramolecular respiration" in the plant tissue, that is due to a natural dying-off of the life substance of the plant cells. From a practical point of view it does not make any difference whether the one or the other explanation is correct. The facts are with us, that if much air is admitted into the silo, through cracks in the wall or through loose packing of the siloed mass, considerable losses of food substances will take place, **first**, because the processes of decomposition are then allowed to go beyond the point necessary to bring about the changes by which the silage differs from green fodder, and, **second**, because the decomposition will cause more or less of the fodder to spoil or mold.

2. The silo must be deep. Depth is essential in building a silo, so as to have the siloed fodder under considerable pressure, which will cause it to pack well and leave as little air as possible in the interstices between the cut fodder, thus reducing the losses of food materials to a minimum. The early silos built in this country or abroad were at fault in this respect; they were shallow structures, not over 12-15 ft. perhaps, and were longer than they were deep. Experience showed that it was necessary to weight heavily the siloed fodder placed in these silos, in order to avoid getting a large amount of moldy silage. In our modern silos no weighting is necessary, since the material placed in the silo is sufficiently heavy from the great depth of it to largely exclude the air in the siloed fodder and thus secure a good quality of silage. In case

of deep silos the loss from spoiled silage on the top is smaller in proportion to the whole amount of silage stored; there is also less surface in proportion to the silage stored, hence a smaller loss occurs while the silage is being fed out, and since the silage is more closely packed, less air is admitted from the top. As the silage packs better in a deep silo than in a shallow one, the former kind of silos will hold more silage per cubic foot than the latter; this is plainly seen from the figures given in the table on page 53. Silos built during late years have generally been over thirty feet deep, and many are forty feet deep or more.

3. The silo must have smooth, perpendicular walls, which will allow the mass to settle without forming cavities along the walls. In a deep silo the fodder will settle several feet during the first few days after filling. Any unevenness in the wall will prevent the mass from settling uniformly, and air spaces in the mass thus formed will cause the surrounding silage to spoil.

4. The walls of the silo must be rigid and very strong, so as not to spring when the siloed fodder settles. The lateral (outward) pressure of cut fodder corn when settling at the time of filling is considerable, and increases with the depth of the silage at the rate of about eleven pounds per square foot of depth. At a depth of 20 feet there is, therefore, an outward pressure of 330 pounds, etc. In case of a 16-foot square silo where the sill is 30 feet below the top of the silage the side pressure on the lower foot of the wall would be about 16×330 , or 5280 pounds.

It is because of this great pressure that it is so difficult to make large rectangular silos deep enough to be economical, and it is because the walls of rectangular silos always spring more or less under the pressure of the silage that this seldom keeps as well in them as it does in those whose walls cannot spring.

As the silage in the lower part of the silo continues to settle, the stronger outward pressure there spreads the walls more than higher up and the result is the wall

may be actually forced away from the silage so that air may enter from above; and even if this does not occur the pressure against the sides will be so much lessened above by the greater spreading below that if the walls are at all open, air will more readily enter through them.

In the round wooden silos every board acts as a hoop and as the wood stretches but little lengthwise there can be but little spreading of such walls, and in the case of stave silos the iron hoops prevent any spreading, and it is on account of these facts that the round silo is rapidly replacing every other form.

After the silage has once settled, there is no lateral pressure in the silo; cases are on record where a filled silo has burned down to the ground with the silage remaining practically intact as a tall stack.

Other points of importance in silo building which do not apply to all kinds of silos, will be considered when we come to describe different kinds of silo structures. Several questions present themselves at this point for consideration viz., how large a silo shall be built, where it is to be located, and what form of silo is preferable under different conditions?

On the Size of Silo Required.

In planning a silo the first point to be decided is how large it shall be made. We will suppose that a farmer has a herd of twenty-five cows, to which he wishes to feed silage during the winter season, say for 180 days. We note at this point that silage will not be likely to give best results with milch cows, or with any other class of farm animals, when it furnishes the entire portion of the dry matter of the feed ration. As a rule, it will not be well to feed over forty pounds of silage daily per head. If this quantity be fed daily, on an average for a season of 180 days, we have for the twenty-five cows 180,000 pounds, or ninety tons. On account of the fermentation processes taking place in the silo, we have seen that

there is an unavoidable loss of food materials during the siloing period, amounting to, perhaps, 10 per cent.; we must, therefore, put more than the quantity given into the silo. If ninety tons of silage is wanted, about one hundred tons of fodder corn must be placed in the silo; we figure, therefore, that we shall need about 4 tons of silage per head for the winter, but, perhaps, 5 tons per head would be a safer calculation, and provide for some increase in the size of the herd.

Corn silage will weigh from thirty pounds, or less, to toward fifty pounds per cubic foot, according to the depth in the silo from which it is taken, and the amount of moisture which it contains. We may take forty pounds as an average weight of a cubic foot of corn silage. One ton of silage will, accordingly, take up fifty cubic feet; and 100 tons, 5,000 cubic feet. If a rectangular one-hundred-ton silo is to be built, say 12x14 feet, it must then have a height of 30 feet. If a square silo is wanted, it might be given dimensions 12x12x35 feet, or 13x13x30 feet; if a circular silo the following dimensions will be about right: Diameter, 16 feet; height of silo, 26 feet, etc. In the same way, a silo holding 200 tons of corn or clover silage may be built of the dimensions 16x24x26 feet, 20x20x25 feet, or if round, diameter, 20 feet, height, 32 feet, etc.

Since the capacity of round silos is not as readily computed as in case of a rectangular silo, we give on following page a table which shows at a glance the approximate number of tons of silage that a round silo, of a diameter from 10 to 26 feet, and 20 feet to 32 feet deep, will hold.

APPROXIMATE CAPACITY OF CYLINDRICAL SILOS, FOR
WELL-MATURED CORN SILAGE, IN TONS.

DEPTH OF SILO, FEET.	INSIDE DIAMETER OF SILO, FEET.												
	10	12	14	15	16	18	20	21	22	23	24	25	26
20.....	26	38	51	59	67	85	105	115	127	138	151	163	177
21.....	28	40	55	63	72	91	112	123	135	148	161	175	189
22.....	30	43	59	67	77	97	120	132	145	158	172	187	202
23.....	32	46	62	72	82	103	128	141	154	169	184	199	216
24.....	34	49	66	76	87	110	135	149	164	179	195	212	229
25.....	36	52	70	81	90	116	143	158	174	190	206	224	242
26.....	38	55	74	85	97	123	152	168	184	201	219	237	257
27.....	40	58	78	90	103	130	160	177	194	212	231	251	271
28.....	42	61	83	95	108	137	169	186	204	223	243	264	285
29.....	45	64	88	100	114	144	178	196	215	235	265	278	300
30.....	47	68	93	105	119	151	187	206	226	247	269	292	315
31.....	49	70	96	110	125	158	195	215	236	258	282	305	330
32.....	51	73	101	115	131	166	205	226	258	271	295	320	346

The following table which has been reproduced from a trade publication shows at a glance how much silage is required to keep eight to forty-five cows for six months, feeding them 40 pounds a day, and the dimensions of circular silos as well as the area of land required to furnish the different amount of feed given, computed at 15 tons per acre. The amount of silage given in the table refers to the number of tons in the silo after all shrinkage has occurred; as the condition of the corn as placed in the silo differs considerably, these figures may vary in different years, or with different crops of corn, and should not be interpreted too strictly; the manner of filling the silo will also determine how much corn the silo will hold; if the silo is filled with well-matured corn, and after this has settled for a couple of days, filled up again, it will hold at least ten per cent. more silage than when it is filled rapidly and not refilled after settling. To the person about to fill a silo for the first time, it is suggested that it requires a "good crop" to yield 15 tons per acre, and as a "little too much is about right," be sure to plant enough to fill the silo full, being guided by the condition of soil, etc., under his control.

Dimensions.	Capacity in Tons.	Acres to fill. 15 Tons to Acre.	Cows it will keep 6 months, 40 lbs. feed per day.
10 x 20	28	3	8
12 x 20	40	3	11
12 x 24	49	3 $\frac{3}{5}$	13
12 x 28	60	4	15
14 x 22	61	4 $\frac{1}{2}$	17
14 x 24	67	4 $\frac{2}{3}$	19
14 x 28	83	5 $\frac{2}{3}$	22
14 x 30	93	6	23
16 x 24	87	6 $\frac{2}{5}$	24
16 x 26	97	7	26
16 x 30	119	8	30
18 x 30	151	10 $\frac{1}{5}$	37
18 x 36	189	12 $\frac{1}{3}$	45

On the Form of Silos.

The first kind of silos built, in this country or abroad, were simply holes or pits in the ground, into which the fodder was dumped, and the pit was then covered with a layer of dirt and, sometimes at least, weighted with planks and stones. Then, when it was found that a large proportion of the feed would spoil by this crude method, separate silo structures were built, first of stone, and later on, of wood, brick or cement. As previously stated, the first separate silos built were rectangular, shallow structures, with a door opening at one end. The silos of the French pioneer Siloist, August Goffart, were about 16 feet high and 40x16 feet at the bottom. Another French silo built about fifty years ago, was 206x21 $\frac{1}{2}$ feet and 15 feet deep, holding nearly 1,500 tons of silage. Silos of a similar type, but of smaller dimensions, were built in this country in the early stages of silo building. Experience has taught siloists that it was necessary to weight the fodder heavily in these silos, in order to avoid the spoiling of large quantities of silage. In Goffart's silos, boards were thus placed on top of the siloed fodder, and

the mass was weighted at the rate of one hundred pounds per square foot.

It was found, however, after some time, that this heavy weighing could be dispensed with by making the silos deep, and gradually the deep silos came more and more into use. These silos were first built in this country in the latter part of the eighties; at the present time none but silos at least twenty to twenty-four feet deep are built, no matter of what form or material they are made, and most silos built are at least twenty-four to thirty feet deep, or more.

Since 1892 the cylindrical form of silos has become more and more general. These silos have the advantage over all other kinds in point of cost and convenience, as well as quality of the silage obtained. We shall, later on, have an occasion to refer to the relative cost of the various forms of silos, and shall here only mention a few points in favor of the round silos.

1. Round silos can be built cheaper than square ones, because it takes less lumber per cubic foot capacity, and because lighter material may be used in their construction. The sills and studdings here do no work except to support the roof, since the lining acts as a hoop to prevent spreading of the walls.

2. One of the essentials in silo building is that there shall be a minimum of surface and wall exposure of the silage, as both the cost and the danger from losses through spoiling are thereby reduced. The round silos are superior to all other forms in regard to this point, as will be readily seen from an example: A rectangular silo, 16x32x24 feet, has the same number of square feet of wall surface as a square silo, 24x24 feet, and of the same depth, or as a circular silo 30 feet in diameter and of the same depth; but these silos will hold about the following quantities of silage: Rectangular silo, 246 tons; square silo, 276 tons; circular silo, 338 tons. Less lumber will, therefore, be needed to hold a certain quantity of silage in case of square silos than in case of rectangular

ones, and less for cylindrical silos than for square ones, the cylindrical form being, therefore, the most economical of the three types.

3. Silage of all kinds will usually begin to spoil after a few days, if left exposed to the air; hence the necessity of considering the extent of surface exposure of silage in the silo while it is being fed out. In a deep silo there is less silage exposed to the surface layer in proportion to the contents than in a shallow one. Experience has taught us that if silage is fed down at a rate slower than 1.2 inches daily, molding is liable to set in. About two inches of the top layer of the silage should be fed out daily during cold weather in order to prevent the silage from spoiling; in warm weather about three inches must be taken off daily; if a deeper layer of silage can be fed off daily, there will be less waste of food materials; some farmers thus plan to feed off 5 or 6 inches of silage daily. The form of the silo must therefore be planned, according to the size of the herd, with special reference to this point. Professor King estimates that there should be a feeding surface in the silo of about five square feet per cow in the herd; a herd of thirty cows will then require 150 square feet of feeding surface, or the inside diameter of the silo should be 14 feet; for a herd of forty cows a silo with a diameter of 16 feet will be required; for fifty cows, a diameter of 18 feet; for one hundred cows, a diameter of $25\frac{1}{4}$ feet, etc.

He gives the following tables showing the number of cows required to eat 1.2 to 2 inches of silage daily in silos 24 to 30 feet deep, assuming that they are fed 40 lbs. of silage daily for 180 or 240 days.

RELATION OF HORIZONTAL FEEDING AREA AND NUMBER OF COWS KEPT, FOR SILOS 24 AND 30 FEET DEEP.

NO. OF COWS.	FEED FOR 240 DAYS.				FEED FOR 180 DAYS.			
	<i>Silo</i> 24 feet deep.		<i>Silo</i> 30 feet deep.		<i>Silo</i> 24 feet deep.		<i>Silo</i> 30 feet deep.	
	Rate 1.2 in. daily.		Rate 1.5 in. daily.		Rate 1.6 in. daily.		Rate 2 in. daily.	
	Tons.	Inside diam.	Tons.	Inside diam.	Tons.	Inside diam.	Tons.	Inside diam.
		Feet.		Feet.		Feet.		Feet.
10...	48	12	48	10	36	10	36	9
15...	72	15	72	12	54	13	54	11
20...	96	17	96	14	72	15	72	12
25...	120	19	120	16	90	16	90	14
30...	144	21	144	18	108	18	108	15
35...	168	22	168	19	126	19	126	16
40...	192	24	192	20	144	21	144	18
45...	216	26	216	21	162	22	162	19
50...	240	27	240	23	180	23	180	20
60...	288	29	288	25	216	25	216	21
70...	336	32	336	27	252	27	252	23
80...	384	34	384	29	288	29	288	25
90...	432	36	432	30	324	31	324	26
100...	480	38	480	32	360	33	360	28

In choosing diameters and depths for silos for particular herds, individual needs and conditions must decide which is best. It may be said, in general, that for the smaller sizes of silos the more shallow ones will be somewhat cheaper in construction and be more easily filled with small powers. For large herds the deeper types are best and cheapest.

One of the most common mistakes made in silo construction is that of making it too large in diameter for the amount of stock to be fed silage. Whenever silage heats and molds badly on or below the feeding surface heavy

loss in feeding value is being sustained, and in such cases the herd should be increased so that the losses may be prevented by more rapid feeding. (King.)

Location of the Silo.

The location of the silo is a matter of great importance, which has to be decided upon at the start. The feeding of the silage is an every-day job during the whole winter and spring, and twice a day at that. Other things being equal, the nearest available place is therefore the best. The silo should be as handy to get at from the barn as possible. The condition of the ground must be considered. If the ground is dry outside the barn, the best plan to follow is to build the silo there, in connection with the barn, going four feet to six feet below the surface, and providing for door opening directly into the barn. The bottom of the silo should be on or below the level where the cattle stand, and, if practicable, the silage should be moved out and placed before the cows at a single handling. While it is important to have the silo near at hand, it should be so located, in case the silage is used for milk production, that silage odors do not penetrate the whole stable, at milking or other times. Milk is very sensitive to odors, and unless care is taken to feed silage *after* milking, and to have pure air, free from silage odor, in the stables at the time of milking, there will be a silage flavor to the milk. This will not be sufficiently pronounced to be noticed by most people, and some people cannot notice it at all; but when a person is suspicious, he can generally discover it. So far as is known this odor is not discernable in either butter or cheese made from silage-flavored milk, nor does it seem to affect the keeping qualities of the milk in any way.

Different Types of Silo Structures.

Silos may be built of wood, stone, brick or cement, or partly of one and partly of another of these materials. Wooden silos may be built of several layers of thin boards

nailed to uprights, or of single planks (staves), or may be plastered inside. The material used will largely be determined by local conditions; where lumber is cheap, and stone high, wooden silos will generally be built; where the opposite is true, stone or brick silos will have the advantage in point of cheapness, while concrete silos are likely to be preferred where great permanency is desired or where cobble-stones are at hand in abundance, and lumber or stone are hard to get at a reasonable cost. So far as the quality of the silage made in any of these kinds of silos is concerned, there is no difference when the silos are properly built. The longevity of stone and concrete silos is usually greater than that of wooden silos, since the latter are more easily attacked by the silage juices and are apt to decay in places after a number of years, unless special precautions are taken to preserve them. A well-built and well-cared-for wooden silo should, however, last almost indefinitely.

As regards the form of the silo, it may be built in rectangular form, square, octagon or round. We have already seen that the most economical of these is ordinarily the round form, both because in such silos there is less wall space per cubic unit of capacity, and in case of wooden round silos, lighter material can be used in their construction. The only place where silos of square or rectangular form are built now is inside of barns, where they fit in better than a round structure. We shall later on give directions for building silos inside of a barn, but shall now go over to a discussion of the various forms of round silos that are apt to be met with. More round wooden silos have been built during late years in this country than of all other kinds of silos combined, and this type of silo, either built of uprights lined inside and outside with two layers of half-inch boards, or of one thickness of staves, will doubtless be the main silo type of the future; hence we shall give full information as to their building, and shall then briefly speak of the other forms mentioned which may be considered preferable in exceptional cases.

Round Wooden Silos.

Round wooden silos were first described, and their use advocated, in Bulletin No. 28, issued by the Wisconsin Station in July, 1891, and hence have come to be known as "Wisconsin Silos." The first detailed and illustrated description of this type of silos was published in this bulletin; since that time it has been described in several bulletins and reports issued by the station mentioned, and in numerous publications from other experiment stations. All writers who have discussed the question of silo construction agree that this form of silos is admirable, and the best that can be put up where a durable, first-class silo of a moderate cost is wanted. This type, and the one to be described in the following, the stave silo, are practically the only kind of wooden silos that have been built in this country during late years, except where unusual conditions have prevailed, that would make some other kind of silo structure preferable.

The following description of the Wisconsin silo is from the pen of Prof. King, the originator of this type of silos, as published in Bulletin No. 83 of the Wisconsin Station (dated May, 1900).

The Foundation—There should be a good, substantial masonry foundation for all forms of wood silos, and the woodwork should everywhere be at least 12 inches above the earth, to prevent decay from dampness. There are few conditions where it will not be desirable to have the bottom of the silo 3 feet or more below the feeding floor of the stable, and this will require not less than 4 to 6 feet of stone, brick, or concrete wall. For a silo 30 feet deep the foundation wall of stone should be 1.5 to 2 feet thick.

The inside of the foundation wall may be made flush with the woodwork above, or nearly so, as represented in Fig. 1, or the building may stand in the ordinary way, flush with the outside of the stone wall, as represented in Fig. 2. In both cases the wall should be finished sloping as shown in the drawings.

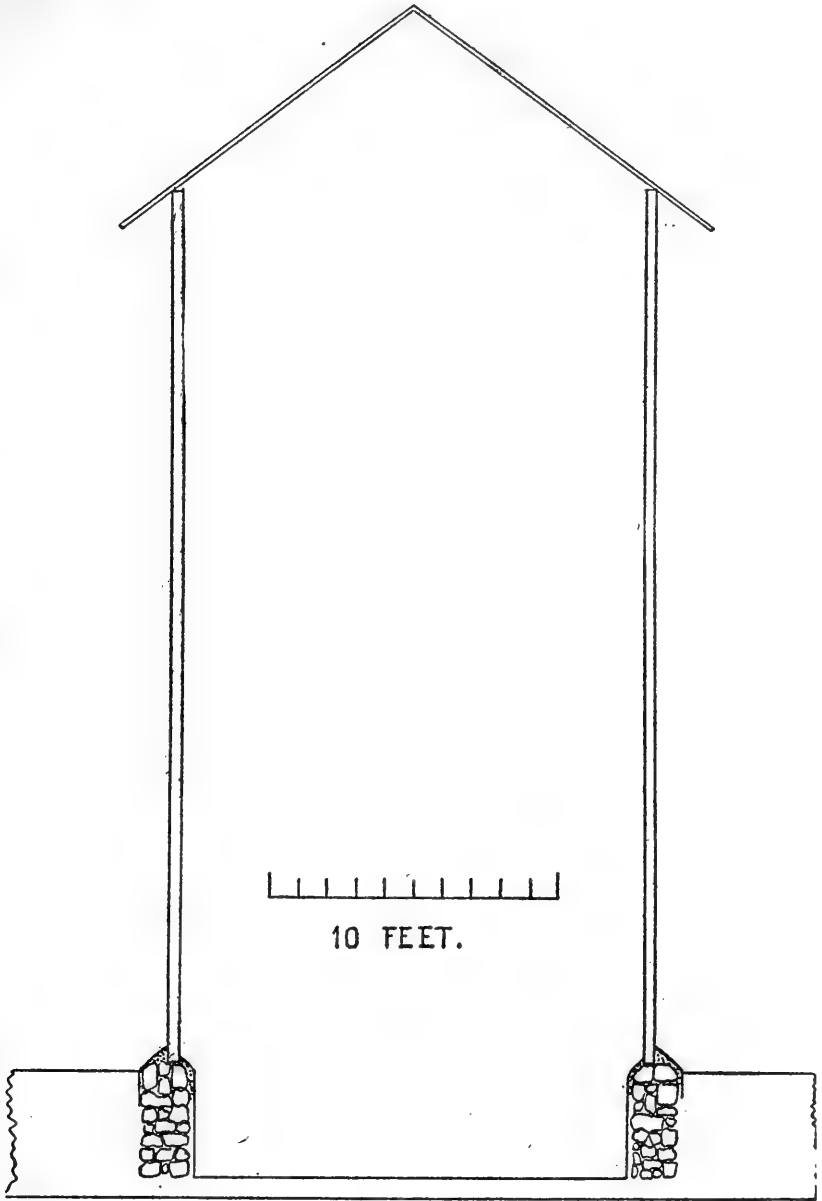

Fig. 1. Showing method of placing all-wood silos on stone foundations, with pit dug out to increase depth.

So far as the keeping of the silage is concerned it makes little difference which of these types of construction is adopted. The outward pressure on the silo wall is greater where the wall juts into the silo, but the wall is better protected against the weather. Where the projecting wall is outside, the silo has a greater capacity, but there is a strong tendency for the wall to crack and allow rain to penetrate it. Where this plan is followed it is important to finish the sloping surface with cement, or to shingle it, to keep out the water.

Bottom of the Silo.—After the silo has been completed the ground forming the bottom should be thoroughly tamped so as to be solid, and then covered with two or three inches of good concrete made of 1 of cement to 3 or 4 of sand or gravel. The amount of silage which will spoil on a hard clay floor will not be large, but enough to pay a good interest on the money invested in the cement floor. If the bottom of the silo is in dry sand or gravel the cement bottom is imperative to shut out the soil air.

Tying the Top of the Stone Wall.—In case the wood portion of the silo rises 24 or more feet above the stone work, and the diameter is more than 18 feet, it will be prudent to stay the top of the wall in some way.

If the woodwork rises from the outer edge of the wall, then building the wall up with cement so as to cover the sill and lining as represented in Figs. 3 and 4 will give the needed strength, because the woodwork will act as a hoop; but if the silo stands at the inner face of the wall, it will be set to lay pieces of iron rod in the wall near the top to act as a hoop.

Where the stone portion of the silo is high enough to need a door, it is best to leave enough wall between the top and the sill to allow a tie rod of iron to be bedded in this portion. So, too, the lower door in the woodwork of the silo should have a full foot in width below it of lining and siding uncut to act as a hoop, where the pressure is strongest.

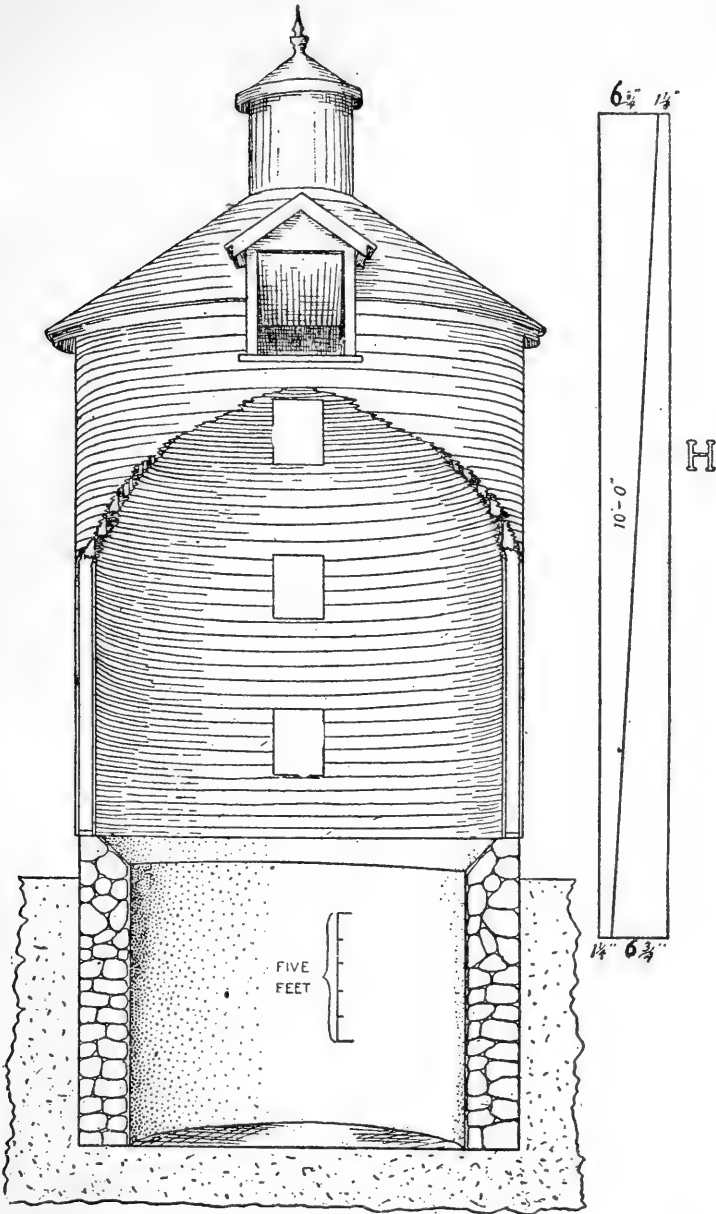

Fig. 2. Showing an all-wood round silo on stone foundation.
H represents a method of sawing boards for the conical roof.

HOW TO BUILD A SILO.

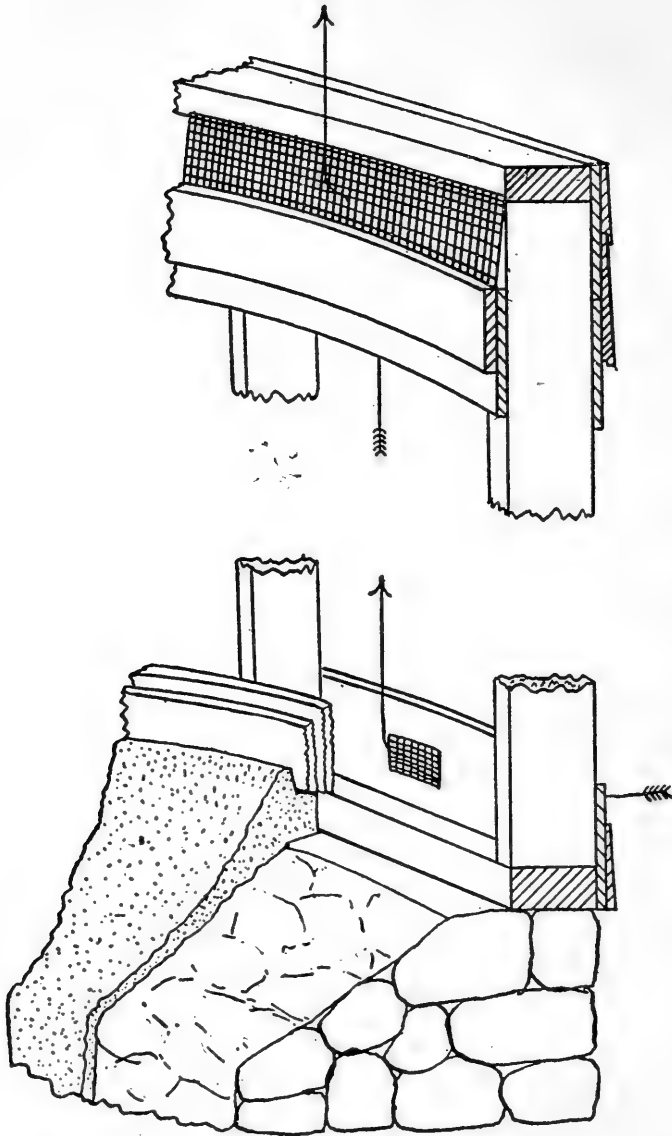

Fig. 3. Showing method of construction for ventilating the spaces between the studding in all-wood and lathed-and-plastered silos.

Forming the Sill.—The sill in the all-wood silo may be made of a single 2x4 cut in 2-foot lengths, with the ends beveled so that they may be toe-nailed together to form circle (Fig. 5).

Setting the Studding.—The studding of the all-wood round silo need not be larger than 2x4 unless the diam-

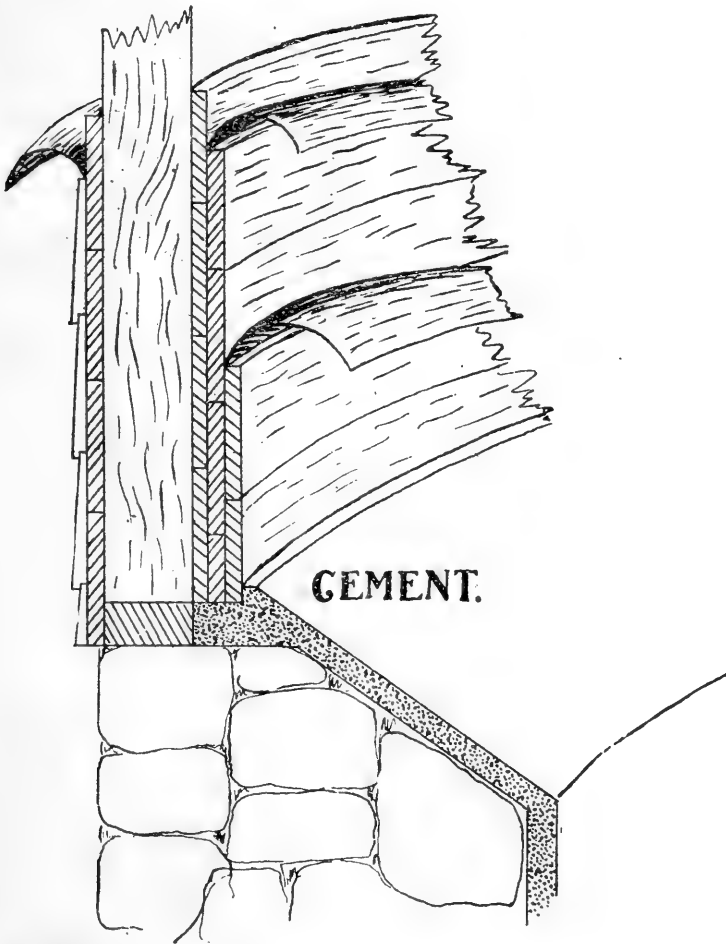

Fig. 4. Showing construction of all-wood silo, and connection with wall, flush with outside.

eter is to exceed 30 feet, but they should be set as close together as one foot from center to center, as represented in Fig. 6. This number of studs is not required for strength but they are needed in order to bring the two layers of lining very close together, so as to press the paper closely and prevent air from entering where the paper laps.

Where studding longer than 20 feet are needed, short lengths may be lapped one foot and simply spiked together before they are set in place on the wall. This will be cheaper than to pay the higher price for long lengths. All studding should be given the exact length desired before putting them in place.

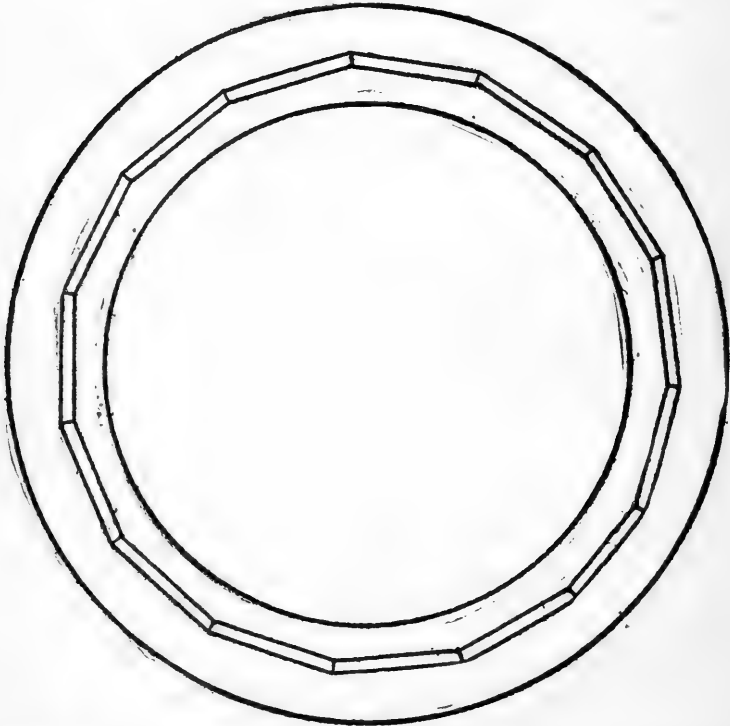

Fig. 5. *Showing method of making the sill of round wood silos.*

To stay the studding a post should be set in the ground in the center of the silo long enough to reach about five feet above the sill, and to this stays may be nailed to hold in place the alternate studs until the lower 5 feet of outside sheeting has been put on. The studs should be set first at the angles formed in the sill and carefully stayed and plumbed on the side toward the center. When a number of these have been set they should be tied together by bending a strip of half-inch sheeting around the outside as high up as a man can reach, taking care to plumb each stud on the side before nailing. When the

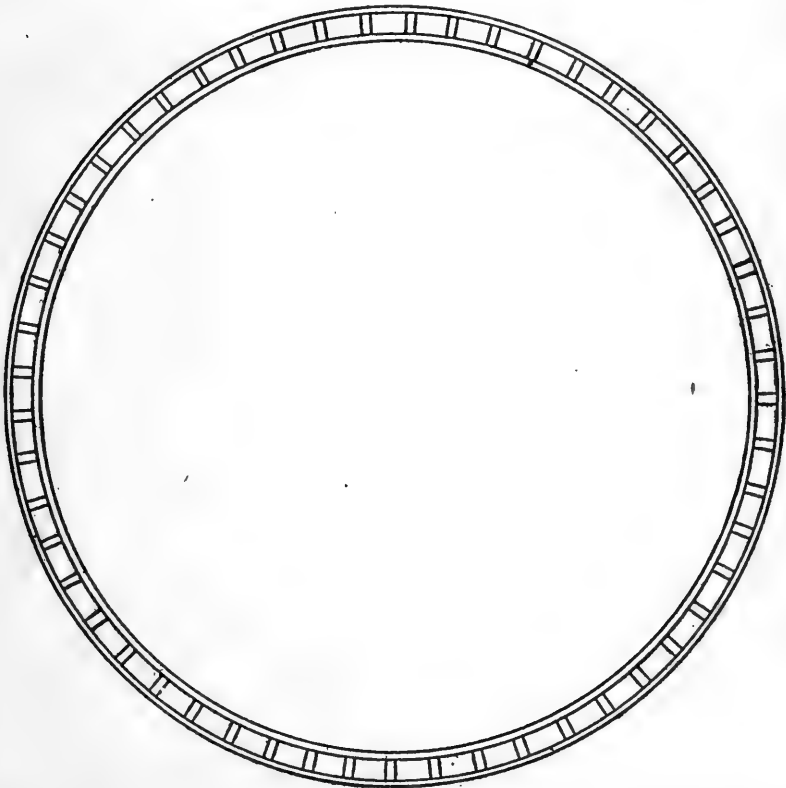

Fig. 6. Showing the plan of studding for the all-wood, brick-lined or lathed-and-plastered silo.

alternate studs have been set in this way the balance may be placed and toe-nailed to the sill and stayed to the rib, first plumbing them sideways and toward the center.

Setting Studding for Doors.—On the side of the silo where the doors are to be placed the studding should be

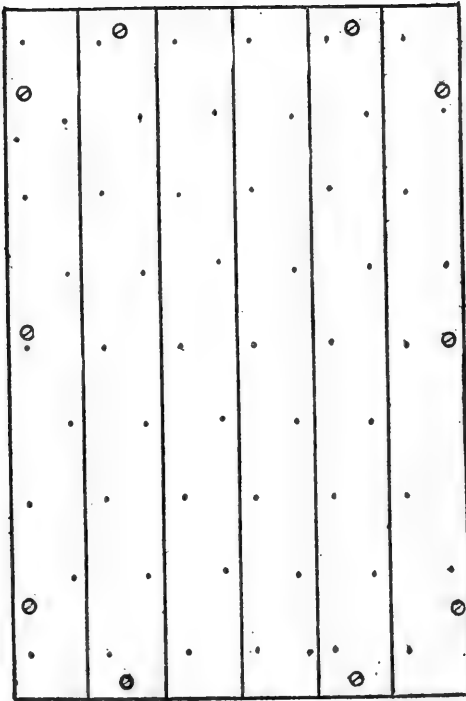
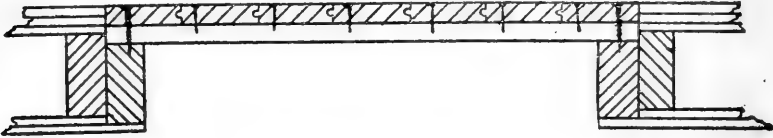

Fig. 7. Showing the construction of the door for the all-wood silo.

set double and the distance apart to give the desired width. A stud should be set between the two door studs as though no door were to be there, and the doors cut out at the places desired afterwards. The construction of the door is represented in Fig. 7.

The doors are usually made about 2 feet wide and from $2\frac{1}{2}$ to 3 feet high, and placed one above the other at suitable distances apart. It has been suggested that to insure security a strip of tar paper should be placed the entire length of the silo on the inside over the doors.

Silo Sheeting and Siding.—The character of the siding and sheeting will vary considerably according to conditions, and the size of the silo.

Where the diameter of the silo is less than 18 feet inside and not much attention need be paid to frost, a single layer of beveled siding, rabbetted on the inside of the thick edge deep enough to receive the thin edge of the board below, will be all that is absolutely necessary on the outside for strength and protection against weather. This statement is made on the supposition that the lining is made of two layers of fencing split in two, the three layers constituting the hoops.

If the silo is larger than 18 feet inside diameter, there should be a layer of half-inch sheeting outside, under the siding.

If basswood is used for siding, care should be taken to paint it at once, otherwise it will warp badly if it gets wet before painting.

In applying the sheeting begin at the bottom, carrying the work upward until staging is needed, following this at once with the siding. Two 8-penny nails should be used in each board in every stud, and to prevent the walls from getting "out of round" the succeeding course of boards should begin on the next stud, thus making the ends of the boards break joints.

When the stagings are put up, new stays should be tacked to the studs above, taking care to plumb each one from side to side; the siding itself will bring them

into place and keep them plumb the other way, if care is taken to start new courses as described above.

Forming the Plate.—When the last staging is up the plate should be formed by spiking 2x4's cut in two-foot lengths, in the manner of sill, and as represented in Fig. 8, down upon the tops of the studs, using two courses, making the second break joints with the first.

The Lining of the Wooden Silo.—There are several ways of making a good lining for the all-wood round silo, but which ever method is adopted it must be kept in mind that there are two very important ends to be secured with

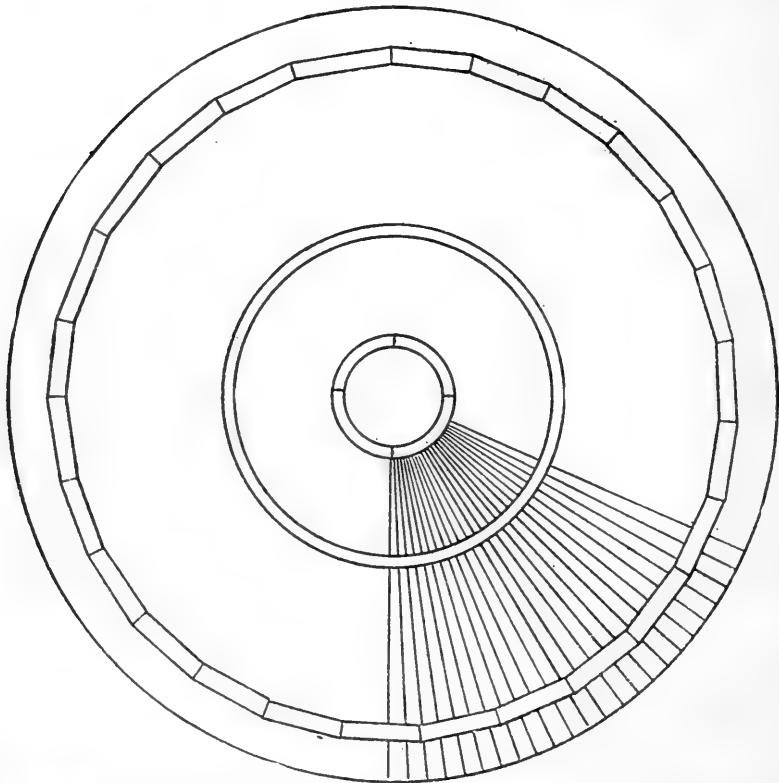

Fig. 8. Showing construction of conical roof of round silo, where rafters are not used. The outer circle is the lower edge of the roof.

a certainty. These are (1) a lining which shall be and remain strictly air-tight, (2) a lining which will be reasonably permanent.

All Wood Lining of 4-inch Flooring.—If one is willing to permit a loss of 10 to 12 per cent. of the silage by heating, then a lining of tongued and grooved ordinary 4-inch white pine flooring may be made in the manner represented in Fig. 9, where the flooring runs up and down. When this lumber is put on in the seasoned condition a single layer would make tighter walls than can be secured with the stave silo where the staves are neither beveled nor tongued and grooved.

In the silos smaller than 18 feet inside diameter the two layers of boards outside will give the needed strength, but when the silo is larger than this and deep, there would be needed a layer of the split fencing on the inside for strength; and if in addition to this there is added a layer of 3-ply Giant P. and B. paper a lining of very superior quality would be thus secured.

Lining of Half-inch Boards and Paper.—Where paper is used to make the joints between boards air-tight, as represented in Fig. 4, it is extremely important that a quality which will not decay, and which is both acid and water-proof be used. A paper which is not acid and water-proof will disintegrate at the joints in a very short time, and thus leave the lining very defective.

The best paper for silo purposes with which we are acquainted is a 3-ply Giant P. and B. brand manufactured by the Standard Paint Co., of Chicago and New York. It is thick, strong, and acid and water-proof. A silo lining with two thicknesses of good fencing have only small knots, and these thoroughly sound and not black, will make an excellent lining. Great care should be taken to have the two layers of boards break joints at their centers, and the paper should lap not less than 8 to 12 inches.

The great danger with this type of lining will be that the boards may not press the two layers of paper together close enough but that some air may rise between the two

sheets where they overlap, and thus gain access to the silage. It would be an excellent precaution to take to tack down closely with small carpet tacks the edges of the paper where they overlap, and if this is done a lap of 4 inches will be sufficient.

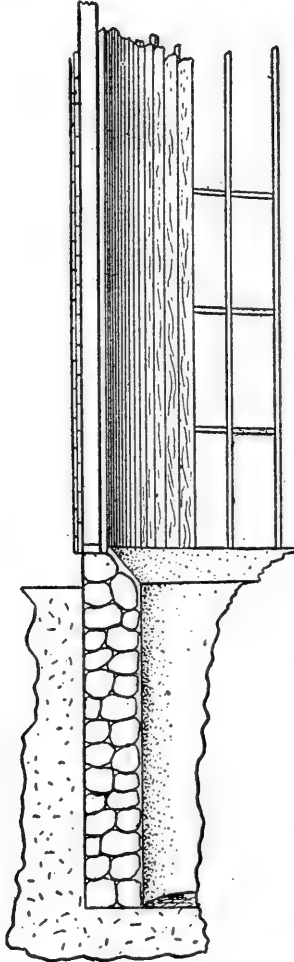

Fig. 9. Showing the construction of the all-wood round silo where the lining is made of ordinary four-inch flooring running up and down, and nailed to girts cut in between the studding every four feet.

The first layer of lining should be put on with 8-penny nails, two in each board and stud, and the second or inner layer with 10-penny nails, the fundamental object being to draw the two layers of boards as closely together as possible.

Such a lining as this will be very durable because the paper will keep all the lumber dry except the inner layer of half-inch boards, and this will be kept wet by the paper and silage until empty, and then the small thickness of wood will dry too quickly to permit rotting to set in.

A still more substantial lining of the same type may be secured by using two layers of paper between three layers of boards, as represented in Fig. 4, and if the climate is not extremely severe, or if the silo is only to be fed from in the summer, it would be better to do away with the layer of sheeting and paper outside, putting on the inside, thus securing two layers of paper and three layers of boards for the lining with the equivalent of only 2 inches of lumber.

The Silo Roof.

The roof of cylindrical silos may be made in several ways, but the simplest type of construction and the one requiring the least amount of material is that represented in Figs. 7 and 8, and which is the cone.

If the silo is not larger than 15 feet inside diameter no rafters need be used; and only a single circle like that in the center of Fig. 8, this is made of 2-inch stuff cut in sections in the form of a circle and two layers spiked together, breaking joints.

The roof boards are put on by nailing them to the inner circle and to the plate, as shown in the drawing, the boards having been sawed diagonally as represented at H, Fig. 2, making the wide and narrow ends the same relative widths as the circumferences of the outer edge of the roof and of the inner circle.

If the silo has an inside diameter exceeding 15 feet it will be necessary to use two or three hoops according to diameter. When the diameter is greater than 25 feet it will usually be best to use rafters and headers cut in for circles 4 feet apart to nail the roof boards to, which are cut as represented at H, Fig. 2.

The conical roof may be covered with ordinary shingles, splitting those wider than 8 inches. By laying the butts of the shingles $\frac{1}{8}$ to $\frac{1}{4}$ of an inch apart it is not necessary to taper any of the shingles except a few courses near the peak of the roof.

In laying the shingles to a true circle, and with the right exposure to the weather, a good method is to use a strip of wood as a radius which works on a center set at the peak of the roof and provided with a nail or pencil to make a mark on the shingle where the butts of the next course are to come. The radius may be bored with a series of holes the right distance apart to slip over the center pivot, or the nail may be drawn and reset as desired. Some carpenters file a notch in the shingling hatchet, and use this to bring the shingle to place.

Ventilation of the Silo.

Every silo which has a roof should be provided with ample ventilation to keep the under side of the roof dry, and in the case of wood silos, to prevent the walls and lining from rotting. One of the most serious mistakes in the early construction of wood silos was the making of the walls with dead-air spaces, which, on account of dampness from the silage, led to rapid "dry-rot" of the lining.

In the wood silo and in the brick lined silo it is important to provide ample ventilation for the spaces between the studs, as well as for the roof and the inside of the silo, and a good method of doing this is represented in Fig. 3, where the lower portion represents the sill and the upper the plate of the silo. Between each pair of studs where needed a $1\frac{1}{4}$ -inch auger hole to admit air is

bored through the siding and sheeting and covered with a piece of wire netting to keep out mice and rats. At the top of the silo on the inside, the lining is only covered to within two inches of the plate and this space is covered with wire netting to prevent silage from being thrown over when filling. This arrangement permits dry air from outside to enter at the bottom between each pair of studs and to pass up and into the silo, thus keeping the lining and studding dry and at the same time drying the under side of the roof and the inside of the lining as fast as exposed. In those cases where the sill is made of 2x4's cut in 2-foot lengths there will be space enough left between the curved edge of the siding and sheeting and the sill for air to enter so that no holes need be bored as described above and represented in Fig. 3. The openings at the plate should always be provided and the silo should have some sort of ventilator in the roof. This ventilator may take the form of a cupola to serve for an ornament as well, or it may be a simple galvanized iron pipe 12 to 24 inches in diameter, rising a foot or two through the peak of the roof.

Painting the Silo Lining.

It is impossible to so paint a wood lining that it will not become wholly or partly saturated with the silage juices. This being true, when the lining is again exposed when feeding the silage out, the paint greatly retards the drying of the wood work and the result is decay sets in, favored by prolonged dampness. For this reason it is best to leave a wood lining naked or to use some antiseptic which does not form a water-proof coat.

The cost of such a silo as that described in the foregoing pages, is estimated by Prof. King at about 12 cents per square foot of outside surface, when the lining consists of two layers of half-inch split fencing, with a 3-ply Giant P. & B. paper between, and with one layer of split fencing outside, covered with rabbetted house siding.

If built inside of the barn, without a roof and not painted, the cost would be reduced 3 cents per square foot, or more. Silos of this type, 30 feet deep, built outside, provided with a roof and including 6 feet of foundation are stated to cost as follows: 13 feet inside diameter (80 tons capacity), \$183.00; 15 feet diameter (105 tons capacity), \$211.00; 21 feet diameter (206 tons capacity), \$298.00; and 25 feet diameter (300 tons capacity), \$358.00.

Complete specifications and building plans for a 300-ton silo, of the kind described in the preceding pages, are given in Prof. Woll's Book on Silage. The dimensions of this silo are: Diameter, 26 feet; height, 30 feet.

According to our present knowledge this form of silo is most likely the best that can be built; it is a somewhat complicated structure, calls for more time and skill for its construction, and costs more than other kinds of wooden circular silos especially more than the stave silo soon to be described; but once built needs but little attention and it is durable and economical, being practically air-tight, the losses of food materials in the siloed fodder are reduced to a minimum.

Modifications of the Wisconsin Silo.

Several modifications of the Wisconsin Silo have been proposed and have given good satisfaction; one is described by Prof. Plumb in Purdue Experiment Station Bulletin No. 91, as follows:

The studs are 18 inches apart, and for about half way up there are three layers of sheeting against the studs with tarred paper between. The upper half of the studs has but two layers of sheeting. The sheeting was made by taking 2x6-inch white pine planks and sawing to make four boards. The silo rests on a stone wall 18 inches deep and 16 inches wide. It is 30 feet high, 18 feet 4 inches inside diameter, and holds about 150 tons. An inexpensive but durable roof was placed upon it. The cost of this

structure is as follows: As the work was all done by the regular farm help at odd hours, the item of labor is given at estimated cost: Studding, \$13.03; sheeting, \$63.00; 5 rolls of paper, \$6.25; nails, \$2.40; cement for wall, \$2.40; labor, \$20.00; total, \$107.08. The owner of the silo was so pleased with the service this one had rendered since its construction, that he built another like it during the summer of 1902. This silo is connected by a covered passage and chute with the feeding floor of the cattle barn.

The construction of this type of silo calls for as much care in putting on sheeting, making doors and keeping out the air at these places and at the foundation, as it required with the more expensive forms previously described. The need for outer siding will depend in a large measure on circumstances. The farmer building the silo (living in Central Indiana) has had no trouble with his silage freezing. In Northern Indiana the siding would naturally be more necessary than in the southern part of this state, but generally speaking, siding is not necessary, although it does materially add to the attractiveness of the silo.

Plastered Round Wooden Silos.

Plastered round wooden silos have met with favor among farmers who have tried them, and are preferred by many for either the original or the modified Wisconsin silo, on account of their ease of construction and their durability. In the experience of H. B. Gurler, a well known Illinois dairyman, who has built several silos on his farm in the course of the last dozen years, the walls of plastered silos keep perfectly and there is no waste from moldy silage along the wall; neither is there any difficulty about cracking of the plaster, if this is put on properly and a good quality of cement is used. Gurler described the construction of his plastered silo in a recent number of *Breeder's Gazette*, accompanying his description with building plans of his silo. We have reproduced the latter changed and improved in some points of minor impor-

tance, and give below a brief description of the method of building silos of this type. (See Figs. 9½ and 10.)

The foundation may be made of stone, brick or cement, and is carried to the proper distance above ground. Sills composed of pieces of 2x4, two feet long, beveled at the ends so as to be toe-nailed together to form a circle of the same diameter as the interior diameter of the silo, are placed on the foundation bedded in asphalt or cemented mortar, and on this the studding is erected, using two by fours, placed 15 or 16 inches apart. Inside sheeting was secured by having 6-inch fencing re-sawed, making the material a little less than ½-inch thick. On this was nailed laths made from the same material, the

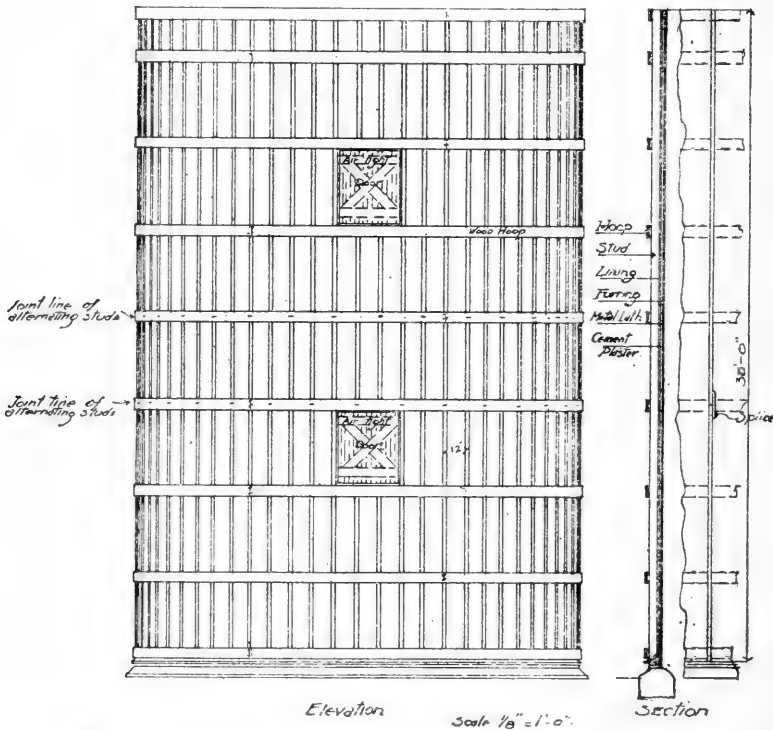

Fig. 9½. Elevation and section of plastered round wooden silo.

laths being made with beveled edges so that when nailed onto the sheeting horizontally, the same way as the sheeting is put on, there are dove-tailed joints between the laths, to receive the cement, preventing its loosening until it is broken. The patent grooved lath might be used, but they cannot be sprung to a twenty-foot circle. Better than either kind of wooden laths, however, is wire netting or metal lath of one form or another, such as is now generally used in outside plastering of houses, nailed on strips of 1x2's which are placed 15 inches apart, and nailed onto the studding through the sheeting. Metal lath will not take up moisture from the silage juices, and thus expand and possibly cause the plaster to crack, as would be likely to occur in case of wooden laths. For outside sheeting

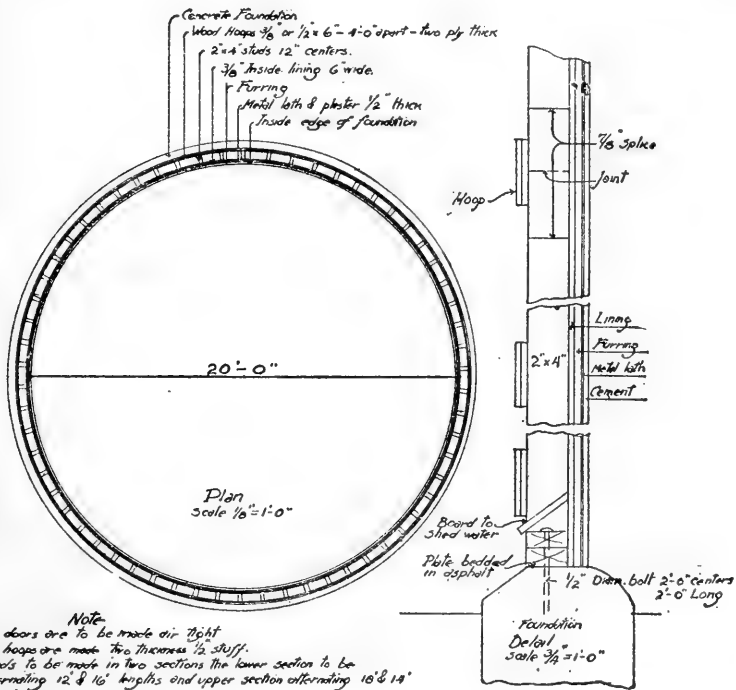

Fig. 10. Foundation plan and section of plastered round wooden silo.

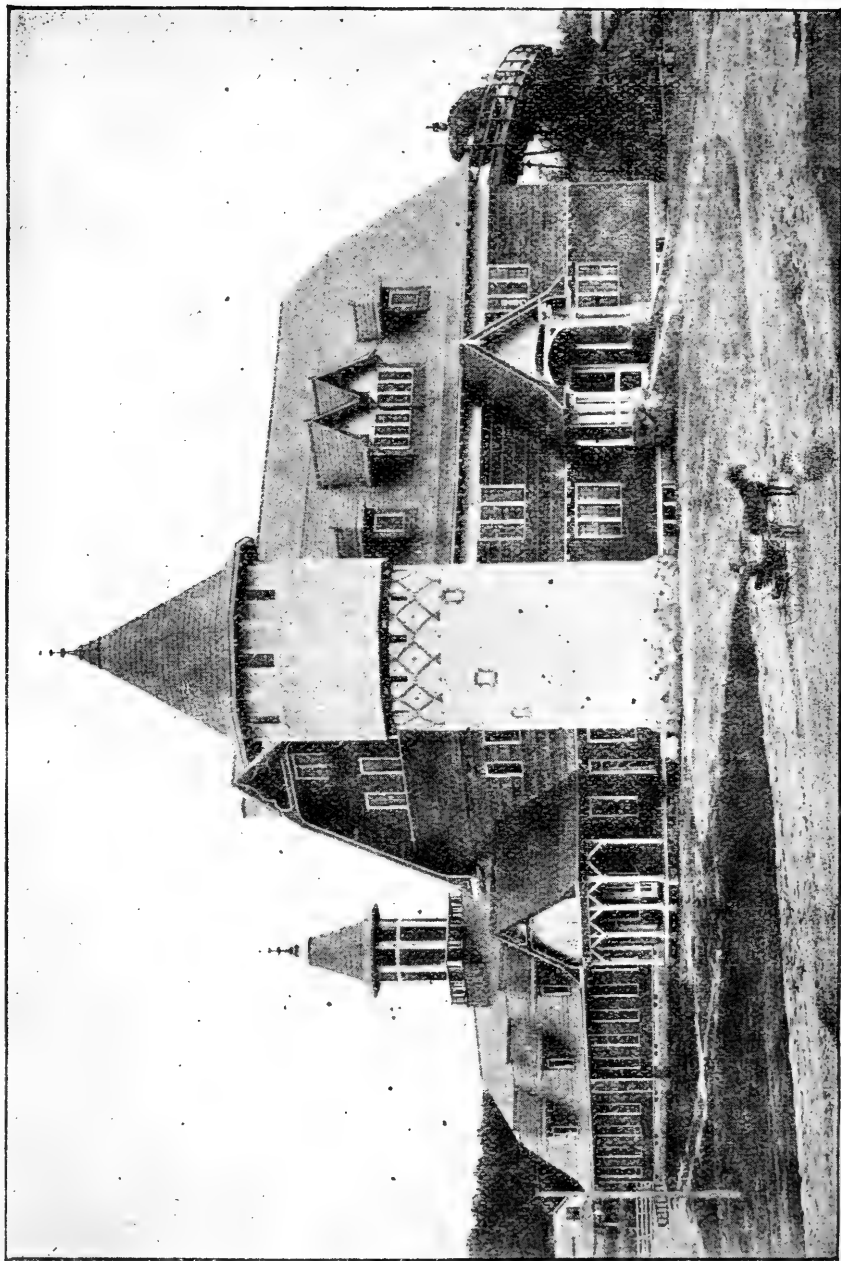

Fig. 11. Dairy Barn, Wisconsin Experiment Station. Brick lined silo in foreground.

similar material as that used for inside sheeting may be used. If built inside of a barn or in a sheltered place, no outside sheeting would be required, although it would add greatly to the looks of the silo. Not being certain that the inside sheeting, laths and cement offered sufficient resistance to the outward pressure in the silo, Mr. Gurler put on wooden hoops outside of the studding, of the same material as for the inside sheeting, putting it on double thickness and breaking joints. The silo described, which would hold 250-300 tons, cost \$300, without a roof. Mr. Gurler considers this silo the best that can be built, and estimates that it will last for at least fifty years, if given a wash of cement every three years and if any cracks that may start be filled before the silo is filled again.

Brick Lined Silos.

As an illustration of silos of this type we give below a description of the silo built in connection with the Dairy Barn of the Wisconsin Experiment Station; the accompanying figures, 11 and 12, will show the exterior appearance of the barn and silo, and a plan of the eastern half of the first floor of this barn.

The silo is circular in form, 18 feet inside diameter and 33 feet deep. It is a framed structure lined inside and outside with brick. On 2x6-inch uprights, two wrappings of $\frac{3}{8}$ -inch stuff, 6 inches wide, are put, breaking joints, with no paper between. Brick is laid tight against this lining, and on the brick surface is a heavy coating of Portland cement (1 part cement, 1 part sand). On the outside brick is laid up against the lining with a small open space between (about $\frac{1}{2}$ inch). The silo is filled from the third floor of the barn, the loads of corn being hauled directly onto this floor over the trestle shown to the right in Fig. 11, and there run through the feed cutter. When the silage is taken out for feeding, it falls through a box chute to the main floor where it is received into a truck (Fig. 30) in which it is conveyed to the mangers of the animals.

HOW TO BUILD A SILO.

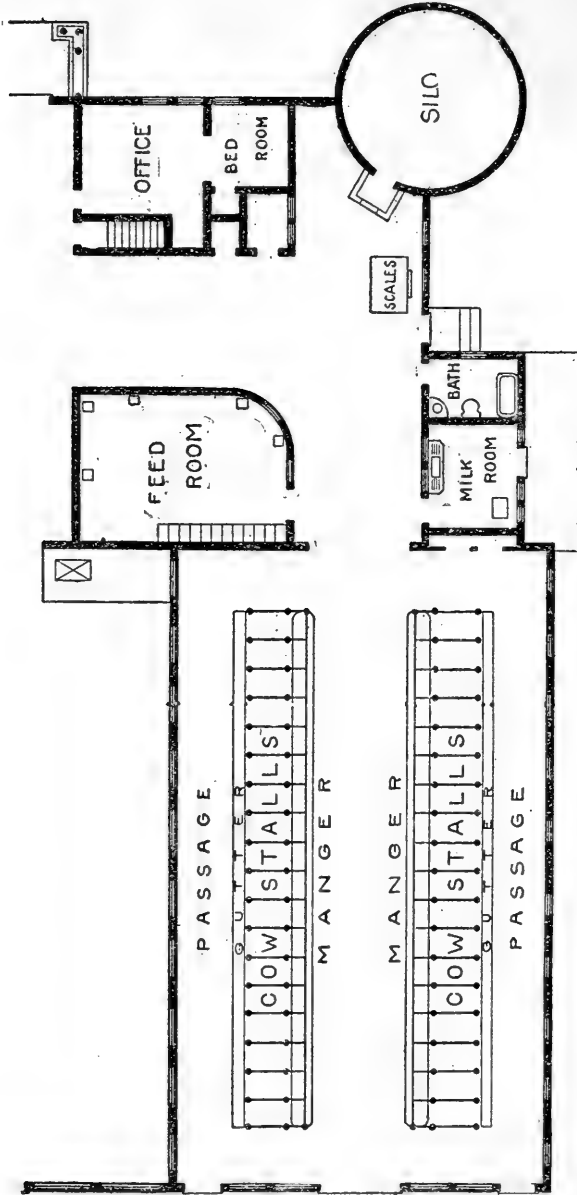

Fig. 12. First floor of barn, showing stables and silo, etc., Wisconsin Experiment Station.

An illustration and description of the original round silo, with a capacity of 90 tons, built at the same Station in 1891 are given in Prof. Woll's Book on Silage, where descriptions and illustrations of a number of other first-class round wooden silos will also be found, like those constructed at the Experiment Stations in New Jersey, Missouri, and South Dakota.

Stave Silos.

The stave silo is the simplest type of separate silo buildings, and partly for this reason, partly on account of its cheapness of construction, more silos of this kind have been built during the past few years than any other silo type.

Since their first introduction Stave Silos have been favorably mentioned by most writers on agricultural topics, as well as by experiment station men. In the recent bulletin from Cornell Experiment Station, we find the stave silo spoken of as "the most practical and successful silo which can be constructed," and the Ottawa Experiment Station is on record for the following statement in regard to the stave silo: "From extensive observation and study of silos and silo construction, and from experience here with a number of different silos, it would appear that the stave silo is the form of cheap silos that for various reasons is most worthy of recommendation. It combines simplicity and cheapness of construction with the requisite conditions to preserve the silage in the very best conditions for feeding."

Stave silos are, generally speaking, similar to large railroad or fermentation tanks, and to make satisfactory silos should be built as well as a No. 1 water tank. The first stave silos were built in this country in the beginning of the nineties; they soon found some enthusiastic friends, while most people, including nearly all writers and lecturers on silo construction, were inclined to be skeptical as to their practicability. It was objected that

the staves would expand so as to burst the hoops when the silo was filled with green fodder; that they would shrink after having been left empty during the summer months, so that the silo would fall to pieces, or at least so that it could not again be made air-tight; and finally, that the silage would freeze in such silos, and its feeding value thereby greatly lowered. In addition to this, it was claimed that a substantial stave silo would cost as much as a first class ordinary all-wood silo of the same capacity, which would not have the objectionable features of the former.

In spite of these objections the stave silo has, however, gradually gained ground, until of late years it has quite generally been adopted in preference to other kinds of silos, particularly in the Eastern and Central states. This being a fact, it follows that the objections previously made to the stave silos, cannot be valid, that the staves do not swell so as to burst the hoops, or shrink so as to cause the silo to fall to pieces, or become leaky. As regards the danger from freezing of the silage, the criticisms of the stave silo are in order, as silage in outdoor stave silos will be likely to freeze in cold weather, in any of the Northern states or Canada; but, according to the testimony of farmers who have had experience with frozen silage, this is more an inconvenience than a loss. The freezing does not injure the feeding value of the silage, or its palatability. When the silage is thawed out it is as good as ever, and eaten by cattle with a relish.

Why Stave Silos Have Become Numerous.

The main reasons why stave silos have been preferred by the majority of farmers during late years are that they can be put up easily, quickly and cheaply, and the expense for a small silo of this kind is comparatively small. Many a farmer has built a stave silo who could not afford to build a high-priced silo, and others have preferred to build two small silos for one large one, or a small one in addition to an old, larger one that they may already have. Manu-

facturing firms have, furthermore, made a specialty of stave-silo construction, and pushed the sale of such silos through advertisements and neat circulars. Having made a special business of the building of stave silos, and having had several years' experience as to the requirements and precautions to be observed in building such silos, these firms furnish silos complete with all necessary fixtures, that are greatly superior to any which a farmer would be apt to build according to more or less incomplete directions.

It follows that the stave silos sent out by manufacturing firms will generally be more expensive than such a farmer can build himself, because they are built better. It does not pay to build a poor silo, however, except to bridge over an emergency. Poor, cheap silos are a constant source of annoyance, expense and trouble, whether built square, rectangular or round. The cheap silos described in other places of this book have not been given for the purpose of encouraging the building of such silos, but rather to show that if a farmer cannot afford to build a permanent **good** silo, he is not necessarily barred from the advantages of having silage for his stock, since a temporary silo may be built at a small cash outlay.

We can therefore consistently recommend that parties intending to build stave silos patronize the manufacturers who have made silo construction a special business. These firms furnish all necessary silo fittings, with complete directions for putting up the silos, and, if desired, also skilled help to superintend their building. Perhaps a large majority of the farmers of the country cannot, however, patronize manufacturers of stave silos because the expense of shipping the lumber and fixtures would be prohibitory. For the convenience of such parties and others who may prefer to build their own stave silos, directions for their construction are given in the following: The specifications for a 100-ton stave silo, printed below, which are taken from Woll's Book on Silage, were furnished by Claude & Starck, Architects, Madison, Wisconsin.

Specifications for 100-ton Silo.

MASONRY.

Excavate the entire area to be occupied by the silo to a depth of six inches; excavate for foundation wall to a depth of 16 inches; in this trench build a wall 18 inches wide and 20 inches high, of field stone laid in rich lime mortar. Level off top and plaster inside, outside and on top with cement mortar, 1 part cement to 1 part sand. Fill inside area with four inches of good gravel, thoroughly tamped down; after the wood work is in place coat this with one inch of cement mortar, 1 part cement to 1 part clean sand. Cement shall be smoothly finished, dished well to the center and brought up at least 2 inches all around inside and outside walls.

CARPENTRY.

All staves shall be 26 feet long in two pieces, breaking joints, and made from clear, straight-grained cypress, 2x6 inches, beveled on edges to an outside radius of 8 feet, mill-sized to the exact dimensions and dressed on all sides. There shall be three doors in the fifth, eighth and tenth spaces between the hoops, made by cutting out from staves 28 inches long cut to a 45-degree bevel sloping to the inside. (See Fig. 13.) The staves shall then be fastened together with two 2x4-inch battens cut on inside to an 8-ft. radius and bolted to each stave with two $\frac{1}{4}$ -inch diameter carriage bolts with round head sunk on inside and nut on outside. The staves between the doors shall be fastened together, top and bottom, with $\frac{3}{4}$ -inch diameter hardwood dowel pins, and abutting ends of staves shall be squared and toe-nailed together.

Bottom Plates.—Bottom plates shall be made of 2x4-inch pieces about 2 feet long, cut to a curve of 7 feet 10 inches radius outside. They shall be bedded in cement mortar and the staves shall then be set on the foundation and well spiked to these plates.

Hoops.—Hoops shall be made from two pieces of $\frac{5}{8}$ -inch diameter round iron with upset ends, threaded 8 inches, with nut and washer at each end; as a support for the hoops a piece of 4x6 shall be substituted for a stave on opposite sides and holes bored in it and the ends of hoops passed through these holes and tightened against the sides of the 4x6-inch. The hoops shall be twelve in number starting at the bottom 6 inches apart and increasing in distance 6 inches between each hoop

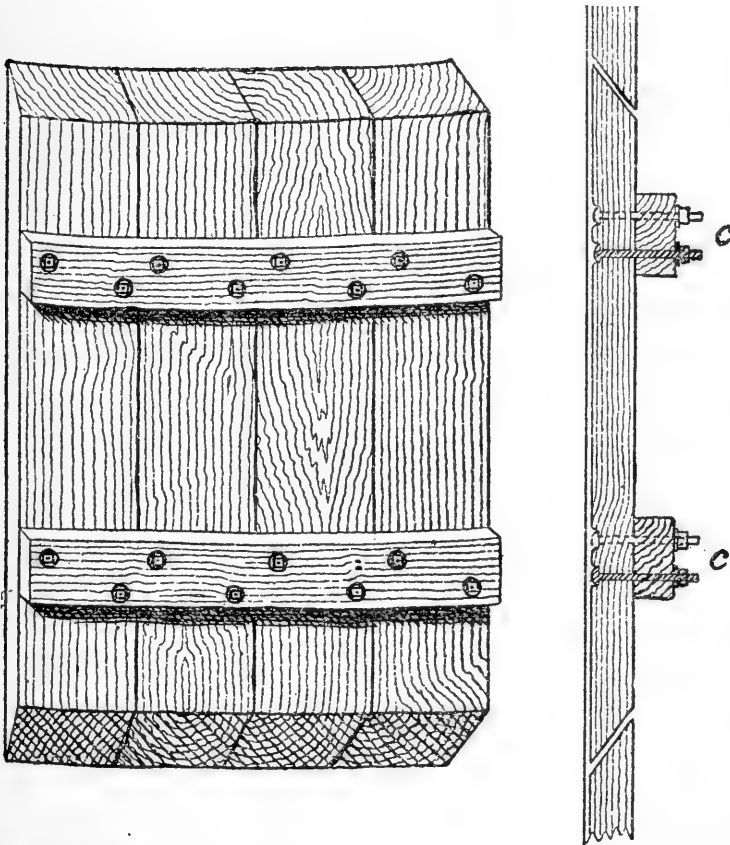

Fig. 13. Appearance of door in stave silo after being sawed out, and side view in place. The opening is largest on the inside of silo. (Clinton.)

until a space of 3 feet 6 inches is reached; from this point up this distance shall be preserved as near as possible to the top.

Roof.—Roof shall be made to a half-pitch of 6-inch clear siding lapping joints, nailed to 2x4-inch rafters, 2-foot centers 1-foot by 4-inch ridge, and 2x4-inch plates. These plates to be supported on two 4x4-inch pieces resting on top of hoops. Three 1x4-inch collar beams shall be spiked

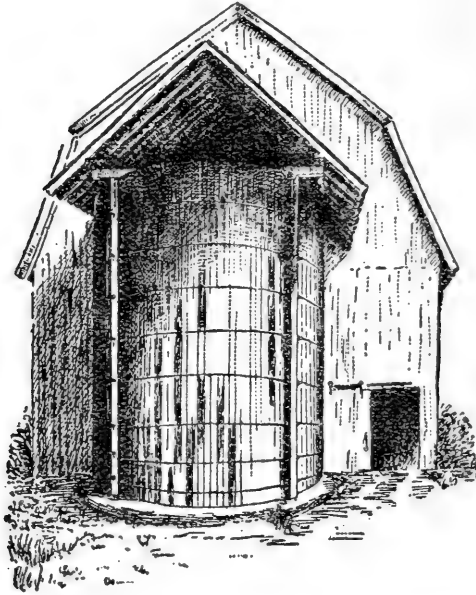

Fig. 14. *A cheap roof of a stave silo. (Clinton.)*

to end and middle rafters to tie side of roof together. See Fig. 11.) Fig. 14 shows another simple construction of roof on a stave silo.

PAINING.

The entire outside of the silo, including roof, shall be painted two coats of good mineral paint; the entire inside surface of the staves and doors shall be thoroughly coated with hot coal tar.

Note.—Before filling silo, tar paper should be tacked tightly over doors and the entire inside of silo examined and cracks tightly caulked.

The method of construction specified in the preceding may of course be modified in many particulars, according to the conditions present in each case, cost of different kinds of lumber, maximum amount of money to be expended on silo, etc.

The following directions for the construction of stave silos are taken from two bulletins on this subject, published by the Cornell and Ottawa Experiment Stations. For a silo 20 feet in diameter, a circular trench 18 inches to two feet wide and with an outer diameter of 22 feet is dug about 2 feet deep, or below the frost line. The surface soil over the whole included area, and for 2 feet outside, is removed to a depth of 10 or 12 inches at the same time. The trench is then filled to the level of the interior with stone, well pounded down, the surface stone being broken quite small, and thin cement (1 part of cement to 4 of sand thoroughly mixed) poured over, well worked in and left for a few days. This is followed by a coat of good cement (1 part cement to 3 sand), care being taken when finished to have the surface level and smooth.

The silo is set up as shown in Fig. 15, which shows a cross-section of one method of construction.

The posts (a, a, a, a) should be of 6x6 material and run the entire length of the silo. These should be first set up vertically and stayed securely in place.

The scaffolding may be constructed by setting up 2 by 4 scantling in the positions shown in Fig. 15, as b, b, b, b. Boards nailed from these 2 by 4 scantling and to the 6 by 6 posts will form a rigid framework, across which the planks for the scaffold platform may be laid. Before the scaffolding is all in place the staves should be stood up within the inclosure; otherwise difficulty will be experienced in getting them into position.

It is probable that no better material can be obtained for the staves than Southern cypress. This, however, is

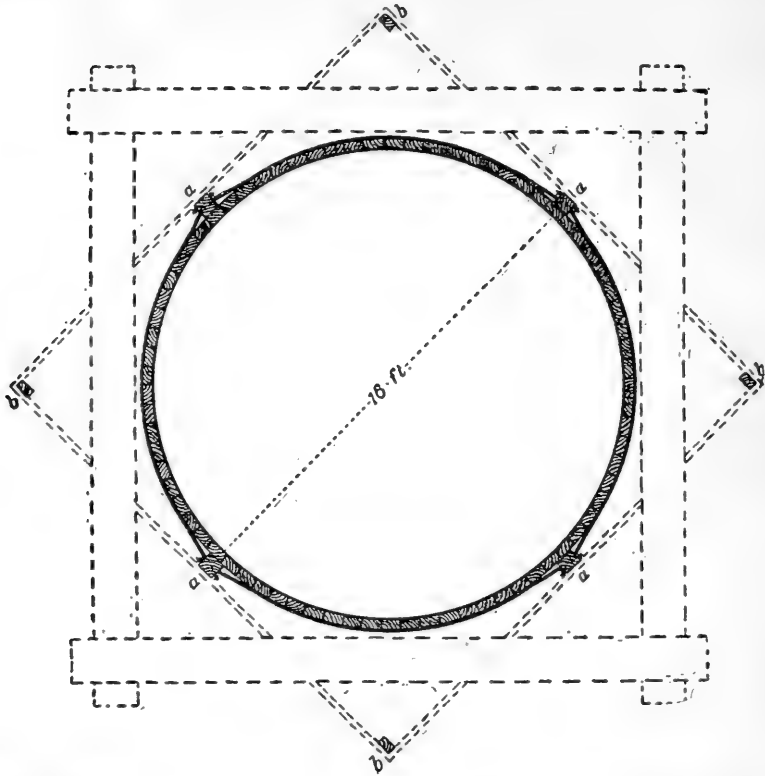

Fig. 15. Cross section of stave silo. The dotted lines show how scaffolding may be put up.

so expensive in the North, as to preclude its use in most cases. Of the cheaper materials hemlock, white pine, and yellow pine, are usually the most available. At the present time hemlock is one of the cheapest satisfactory materials which can be purchased, and it is probably as good as any of the cheaper materials. It should be sound and free from loose knots.

If the silo is to have a diameter of 12 feet or less, the staves should be made of either 2 by 4 material, unbeveled on the edges and neither tongued nor grooved, or of 2 by 6 material beveled slightly on the edges to make the staves conform to the circular shape of the silo. If the

silos is to have a diameter of more than 12 feet, the staves should be of 2 by 6 material, and neither beveled nor tongued and grooved on the edges. The staves should be surfaced on the inside so that a smooth face may be presented which will facilitate the settling of the silage. The first stave set up should be made plumb, and should be toe-nailed at the top to one of the posts originally set.

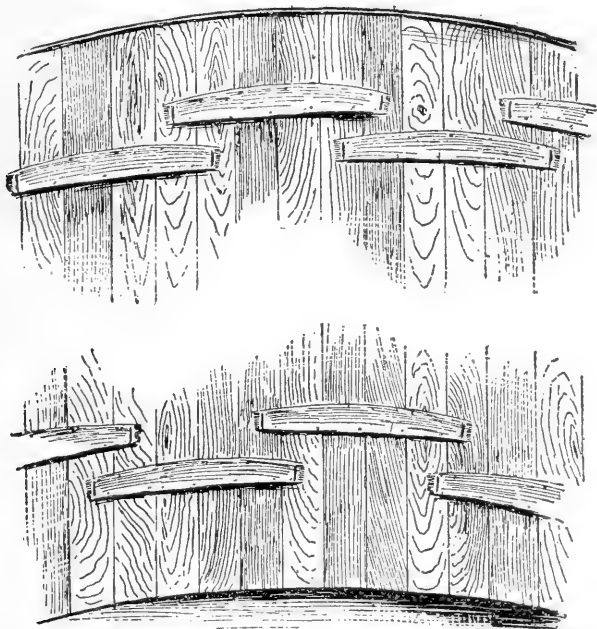

Fig. 16. Shows how barrel staves may be used in setting up a silo. They should be removed before the silo is filled.

Immediately a stave is set in place it should be toe-nailed at the top to the preceding stave set. It has been found that the work of setting up and preserving the circular outline may be materially aided by the use of old barrel staves (see Fig. 16.) For a silo 12 feet in diameter the curve in the stave of the sugar barrel is best adapted; for a 16-foot silo the flour barrel stave is best, and for a silo 20 feet or more in diameter the stave of the cement

barrel is best. If when the silo staves are put in place they are toe-nailed securely to the ones previously set; if they are fastened firmly to the permanent upright posts (Fig. 15, a, a, a, a); if the barrel staves are used as directed above, the silo will have sufficient rigidity to stand until the hoops are put in place. However, if it becomes necessary for any reason to delay for any considerable time the putting on of the hoops, boards should be nailed across the top of the silo.

When it is found impossible to secure staves of the full length desired, a joint or splice must be made.

For a silo 30 feet deep, staves 20 feet in length may be used. A part of these should be used their full length and part should be sawed through the middle, thus making staves of 20 and 10 feet length. In setting them up the ends which meet at the splice should be squared and toe-nailed securely together. They should alternate so that first a long stave is at the bottom then a short one, thus breaking joints at 10 feet and 20 feet from the base.

For the hoops, $\frac{5}{8}$ -inch round iron or steel rods are recommended, although cheaper substitutes have been found satisfactory. Each hoop should be in three sections for a silo 12 feet in diameter, in four sections for a silo 16 feet in diameter. If the method of construction shown in Fig. 15 is followed, the hoops will need to be in four sections each, the ends being passed through the upright 6x6 posts, and secured by heavy washers and nuts. The bottom hoop should be about six inches from the base of the silo; the second hoop should be not more than two feet from the first; the third hoop two and one-half feet from the second, the distance between hoops being increased by one-half foot until they are three and one-half feet apart, which distance should be maintained except for the hoops at the top of the silo which may be four feet apart. The hoops should be drawn fairly tight before the silo is filled, but not perfectly tight. They must be tight enough to close up the space between the staves, thus preventing any foreign matter from getting into the cracks

which would prevent the staves from closing up as they swell, and allow air to enter. To hold hoops and staves in place during the summer when the silo is empty, staples should be driven over the hoops into the staves. If a sufficient number of staples are used they will prevent the sagging or dropping down of the hoops, and they will hold the staves securely in place.

The hoops should be watched very closely for a few days after the silo is filled. If the strain becomes quite intense the nuts should be slightly loosened. If during the summer when the silo is empty and the staves thoroughly dry the hoops are tightened so that the staves are drawn closely together when the silo is filled and the wood absorbs moisture and begins to swell, the hoops must be eased somewhat to allow for the expansion.

The doors, 2 feet wide by $2\frac{1}{2}$ feet high, should be located where convenience in feeding dictates. The lower door should be between the second and third hoops at the bottom, and other doors will usually be needed in every second space between there and the top, except that no door will be needed in the top space, as the silage when settled will be sufficiently low to enable it to be taken out at the door in the space below. Plans should be made for the doors at the time the staves are set. When the place is reached where it is desired to have the doors; a saw should be started in the edge of the stave at the points where the top and bottom of the doors are to come. The saw should be inserted so that the door can be sawed out on a bevel, making the opening larger on the inside of the silo. (See Fig. 13). This will enable the door to be removed and put in place only from the inside, and when set in place and pressed down with silage the harder the pressure the tighter will the door fit. After the silo is set up and the hoops have been put on and tightened the cutting out of the doors may be completed. Before doing this, cleats 2 inches by 3 inches and in length equal to the width of the door, should be made which will conform to the circular shape of the silo. One of these cleats should

be securely bolted to the top and one to the bottom of where the door is to be cut. (See Fig. 13.) After the bolting, the door may be sawed out, and it is then ready for use. When set in place at time of filling the silo a piece of tarred paper inserted at the top and bottom will fill the opening made by the saw and prevent the entrance of any air around the door.

Another Door for Stave Silo.

Silage being heavy to handle, and pitch up, has made continuous doors a popular feature of a few factory-built silos, as it is much easier to get the silage out of the silo for feeding. The illustration, Fig. 17, shows a method of making a door in homemade silos which is continuous with the exception of a narrow brace piece extending across the opening, under each hoop, to give rigidity to the structure. These pieces should be securely toe-nailed at each end to the staves. The jamb pieces, e, e, should be 2 inches thick, beveled off on the side away from the door, securely spiked to the inside of the stave, as shown, so as to leave a rabbet 2x2 inches. Great care should be taken to have these pieces exactly the same distance apart throughout their entire length, so that the door boards, being sawed the exact length, will fit alike and properly all the way up, and if care be taken in this regard it will not be necessary to replace them in the same order at each successive filling of the silo. The door boards should be matched, two inches thick the same as the staves, and if surfaced and well seasoned there need be no fear of the silage spoiling around such a door. A strip of acid and water-proof paper may be placed in the rabbet, between the ends of the door boards and the stave, as an extra precaution, but if the carpenter work is well done it is not absolutely necessary.

Such a door can be adapted to any form of stave silo, and, if not more than two feet wide, the fact that the door section is straight instead of curved will make no difference.

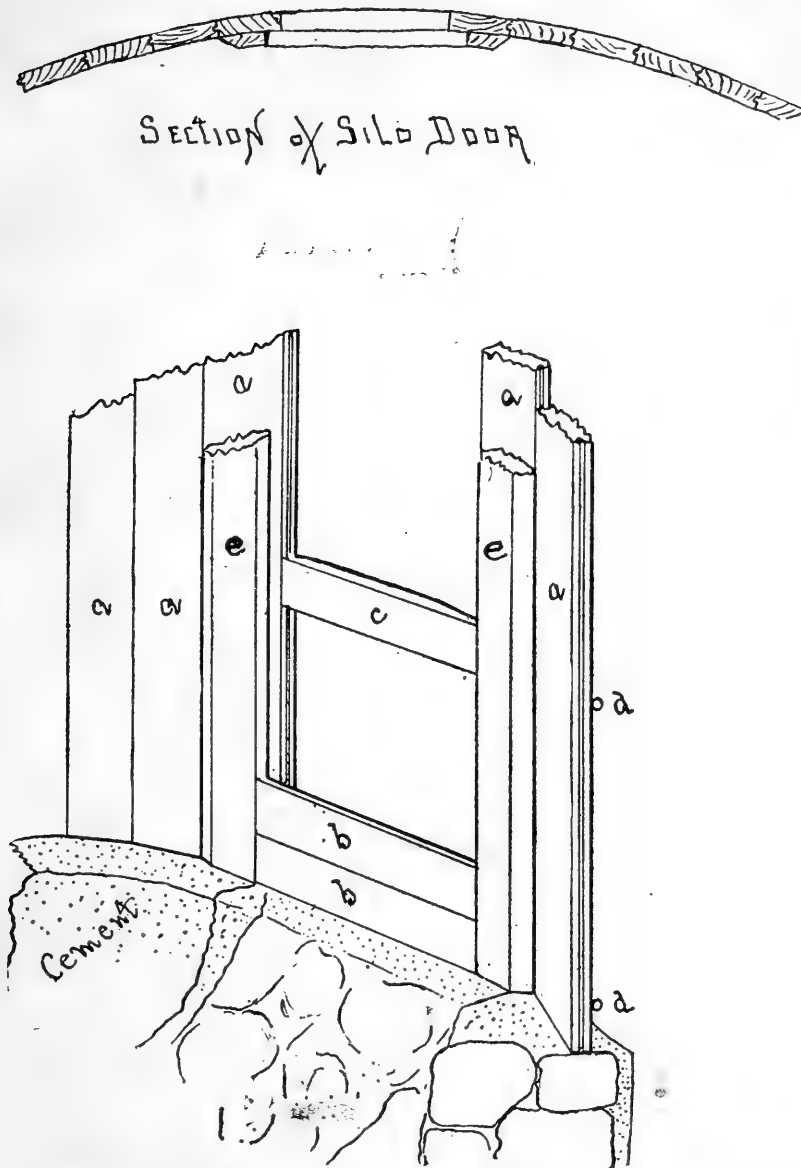

Fig. 17. *a, a*, Staves. *b, b*, Door Boards. *c*, Brace $2\frac{1}{2}$ by 6, set in. *d, d*, Hoops. *e, e*, Jamb Pieces.

If the silo is built outside of the barn some sort of a roof is desirable. This should be sufficiently wide to protect the walls of the silo as thoroughly as possible. A very satisfactory roof is shown in Fig. 14. Two other constructions of a cheap roof for a stave silo are shown in Figs. 18 and 19. The latter was built at the Indiana Experiment Station at a total cost of \$10.50, viz., lumber \$4.00, tin put on and painted \$6.00 and hardware 50 cents. Two 2x6 pieces (AA) were placed on edge and toe-nailed to the top of the staves they rested on; the projection is for supporting the carrier at filling time. They are tied together by the short pieces E. The roof is in three sections, G, H, and I. G and H are hinged to the frame A, A, and may be tipped up when the silo is nearly full,

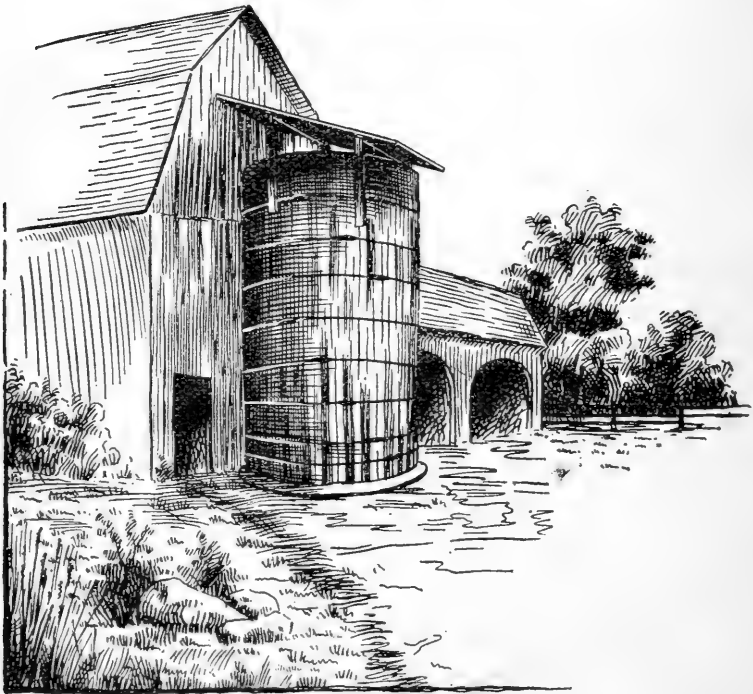

Fig. 18. *A cheap roof for stave silos.*

to allow filling to the top. The narrow middle section is light enough to lift off on either side, and leaves the opening for the carrier to deliver into.

On the framework B, B, and C, C, cheap sheeting boards are nailed. This is then covered with tin, soldered

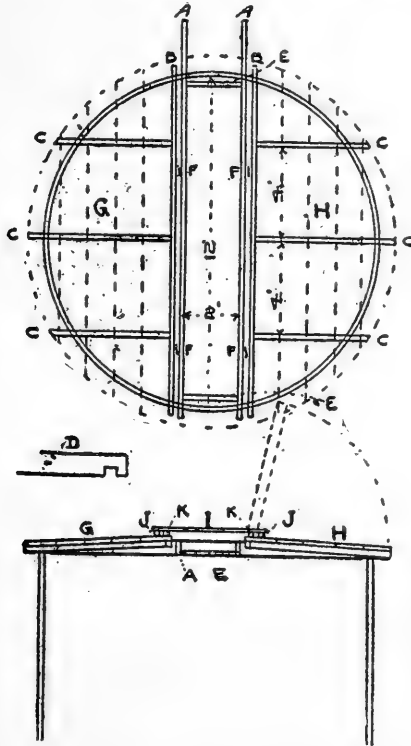

Fig.19. A CHEAP ROOF OF STAVE SILO.

A, B, and E, 2x6 in.; C, 2x4 in.; D, E, Enlarged Outside End; F, Hinges; G, H, I, Sections of Roof; J, K, 2x2 in. (Van Norman.)

joints and painted. The sections should be fastened down by means of staples and hooks, or other device; the hooks are used on this one. On the inner edge of G and H, 2x2-inch strips, K, are nailed. Close to these are placed similar strips, J, to which the cross-boards are nailed,

forming the section I of the roof. The tin on the section I should come over to the side of J. On the other sections it should run up on the side of K, making a water-tight joint.

The sections G and H have slope of nearly 3 inches, being the difference in height of A and C. C is notched one inch at the outer end. (Van Norman.)

Cheap Stave Silos.

A foundation, bottom, and roofless stave silo was described recently in Hoard's Dairyman, which may prove of interest and value to some readers. It was put up on a leased farm, with the expectation of removing it on the termination of the lease. It has the sky for a roof, the ground for a bottom, and no foundation but a 2x6 spruce scantling to secure a level base for the wall, while protecting them from rotting on the ground. The silo has a diameter of 24 feet, and is as high as could be built from 2x4 scantling without splicing them. The 2x4 spruce scantlings were set 18 inches apart from center to center, upon a 2x6 sill, directly upon the ground. It was sheeted on the inside with two thicknesses of $\frac{1}{2}$ x6 spruce, with tar paper between. On the outside, at the bottom, half way up, and at the top, were two, three, and two bands of 1x6 common fencing, respectively, and no other boarding. The silo has a capacity of 250 tons, and was built at a cost of \$174.21. "We never had better silage than we are now feeding out of this silo, though we did have to shovel nearly a foot off of it a few days ago, when the silo was opened."

A Modification of the Stave Silo.

Stave silos are admittedly cheap and readily put up, but unless hoops are tightened as they dry out, they may be easily blown into a shapeless mass in case of a heavy gale. The modification of the stave silo described in the following has the advantage of being more rigid and sub-

stantial; it has been put up in a number of places in the east, and has apparently given good satisfaction for several years at least. In building this silo some good, tough oak plank two inches thick and of any convenient length are procured. Rock elm will do, although not as good as oak. The planks are sawed into strips half an inch thick. The foundation of the silo is made of concrete, and a little larger than the outside diameter of the silo. A stake is set in the center and on this a piece is nailed, just long enough to act as a guide in setting scantling when erecting sides. For sides $1\frac{1}{2}$ x4-inch hemlock of any desired length is used. These are set up on the circumference of the silo, perpendicular to the bottom, 3 feet and 7 feet up nail on the outside one of the half-inch strips mentioned before, being sure to keep the circle regular. This will keep upright pieces in place until the circle is completed. On each hoop so started other half-inch pieces are nailed, lapping them in different places until each hoop is three inches thick. Other hoops are now put on in the same manner, placing them one foot apart at bottom, up to the three-foot hoop 16 inches apart from three to the 7-foot hoop, then increasing the distance between each hoop two inches, until they are 30 inches apart, at which distance they should be kept. If staves are to be spliced it should be done on the hoop. When this is done, a silo will be made of $1\frac{1}{2}$ x4 inch, thoroughly hooped with wooden hoops 2x3 inches.

The inside may be covered with the best quality of felt, well tacked to the staves, on which a thick coat of thick coal tar is spread; over this another thickness of felt is put while the tar coating is still green. The silo is lined with $\frac{3}{8}$ -inch Georgia pine ceiling, nailing thoroughly, and the lining coated with two coats of coal tar, putting on the first one quite thin, but using all the wood will take in, and for a second coat tar as thick as can be spread. Give plenty of time to dry before filling.

The outside of the silo may be boarded up with vertical boarding, or it may have strips nailed on hoops and

be boarded with novelty siding. The latter method will make a stronger and better looking silo. If the hoops are well nailed to the staves when being made, we shall have a silo in which it is impossible for the staves to shrink or get loose. (Woodward.)

Peer, in his book "Soiling, Soiling Crops and Ensilage," reports that a New York canning factory who has for years siloed their pea vines, corn husks and cobs, and wintered sheep thereon, put the refuse through a cutting box into a rough plank silo about thirty feet in diameter. "The planks were rough, just as they came from the saw mill, set on end, and hooped with half-inch iron. No roof was put on, and when the silage settled the staves were taken down, the silage stood, and the whole mass kept in perfect form. The following year the staves (2x6 inch planks) are set up again. As to the silage spoiling, there is six or eight inches on the side that rots, and is thrown into the manure heap. As to freezing, they experienced no inconvenience from that. If the top freezes a little, it is mixed with the unfrozen, fermentation sets up, and the frozen part is thawed out by its own combustion.

Protection against freezing. If the silo is built outdoors in any of the Northern states, it is necessary to provide some special means to keep the silage from freezing in case this is considered a very objectionable feature. The silo may be inclosed by a wide jacket of rough boards nailed to four uprights, leaving the section of the silo where the doors are easy of access; the space between the silo and outside jacket is filled with straw in the fall; this may be taken out and used for bedding in the spring, thus allowing the staves to be thoroughly dried out during the summer, and preventing the silo from rotting.

Number of staves required for stave silos.—The following table will be found useful in calculating the number of staves required for silos of different diameters, and feeding areas which these will give:

TABLE OF AREAS AND CIRCUMFERENCES. 101

CIRCUMFERENCES AND AREAS OF CIRCLES.

Diameter, Feet.	Circum- ference, Feet.	Area, Square Feet.	Diameter, Feet.	Circum- ference, Feet.	Area, Square Feet.
8	25.1	50.3	21	66.0	346.4
9	28.3	63.6	22	69.1	380.1
10	31.4	78.5	23	72.3	415.5
11	34.6	95.0	24	75.4	452.4
12	37.7	113.1	25	78.5	490.9
13	40.8	132.7	26	81.7	530.9
14	44.0	153.9	27	84.8	572.6
15	47.1	179.7	28	88.0	615.8
16	50.3	201.1	29	91.1	660.5
17	53.4	227.0	30	94.2	706.9
18	56.5	254.5	31	97.4	754.8
19	59.7	283.5	32	100.5	804.2
20	62.8	314.2			

To find the circumference of a circle, multiply the diameter by 3.1416.

To find the area of a circle, multiply the square of the diameter by 0.7854.

To find the cubical contents of a cylinder, multiply the area of the base (floor) by the height.

Example.—A silo 16 feet in diameter and 26 feet high is wanted; how many staves 2x6 inches will be needed, and what will be the feeding area in the silo and its capacity?

The circumference of a circle 16 feet diameter is 50.3 feet; there will therefore be required $50.3 \div \frac{1}{2} = 101$ staves, 2x6 inches, 26 feet high, or if staves of this height cannot be obtained, 135 staves 20 feet long, or 50 each of 12 and 14 feet long staves. The feeding area will be $16 \times 16 \times 0.7854 = 201.1$ square feet, and the cubical content of the silo, $201.1 \times 26 = 5228.6$ cubic feet. Estimating the weight of a cubic foot of corn silage at 40 pounds, 5228.6 cubic feet of silage would weigh 209,164 pounds, or about 100 tons, which is the approximate capacity of a round silo of the dimensions given.

Connecting Round Silos with Barn.—The location of the silo with reference to other farm buildings has already been discussed. The silo must be easy to get at from the stable, and the silage, if possible, handled only once in being placed before the stock. A round silo is most conveniently built just outside of the barn and connected with this by means of covered passage way. The method of joining silos to barns is illustrated in numerous pictures of silos given in this book. (See Fig. 20.)

Other Forms of Round Silos.

The various types of round, wooden silos have been described at some length in the preceding, because perhaps ninety per cent. of farmers who expect to build a silo will build one of this kind, either one of the more substantial and expensive original or modified Wisconsin silos, or a stave silo. In some cases it seems more desirable to build a round silo of other material than wood, viz., of either stone or brick. The general principles that must be observed in constructing silos of these materials are similar to those underlying the proper construction of wooden silos. In order to strengthen the wall of the silo, it is recommended to bed in the wall between the doors $\frac{5}{8}$ inch iron rods, bent to the curve of the silo circle, and about 12 feet long. The two ends should be turned short at right angles, so as to anchor better in the mortar. In deep stone silos, which rise more than 18 feet above the surface of the ground, it will be safest to strengthen the wall between the two lower doors with iron tie rods, and, if such a silo is built of boulders, it will be well to use rods enough to have a complete line or hoop around the silo about two feet above the ground, as represented in Fig. 21.

Too great care cannot be taken in making the part of the wall below and near the ground solid, and especially its outer face, so that it will be strong where the greatest strain will come. It is best also to dig the pit for the silo large enough so as to have plenty of room outside of the

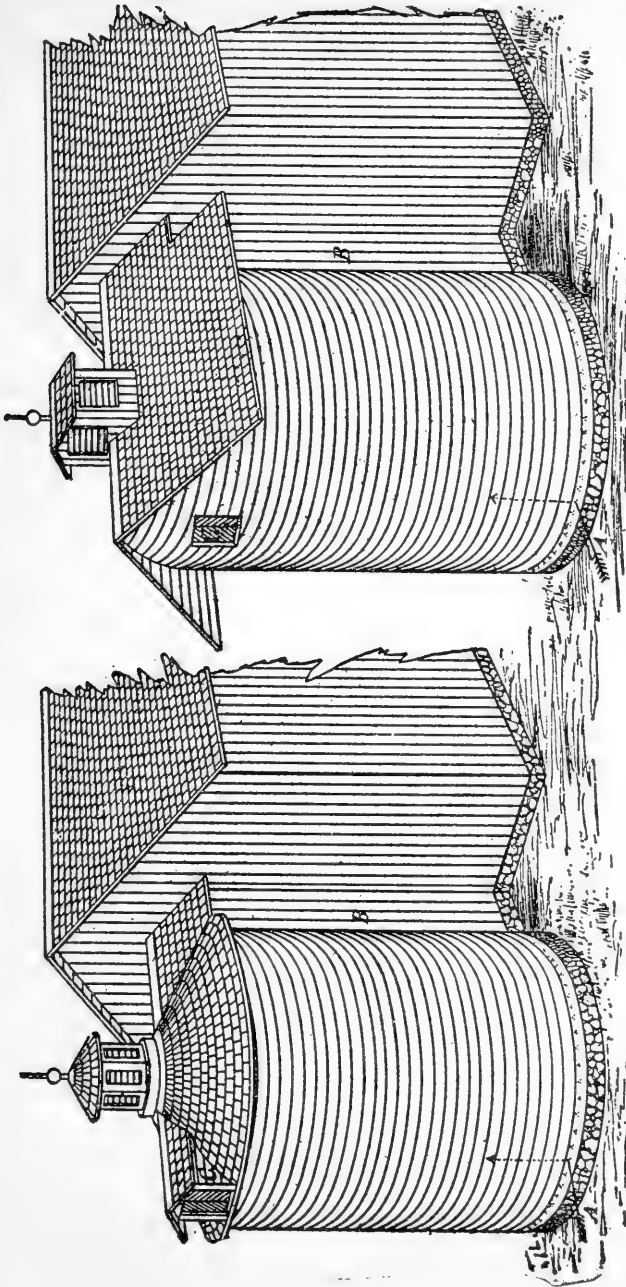

Fig. 20. Two methods of roofing round wooden silos, and the manner of connecting them with the barn so as to provide a feeding chute.

finished wall to permit the earth filled in behind to be very thoroughly tamped, so as to act as a strong backing for the wall. This is urged because a large per cent. of the stone foundations of wood silos have cracked more or less from one cause or another, and these cracks lead to the spoiling of silage.

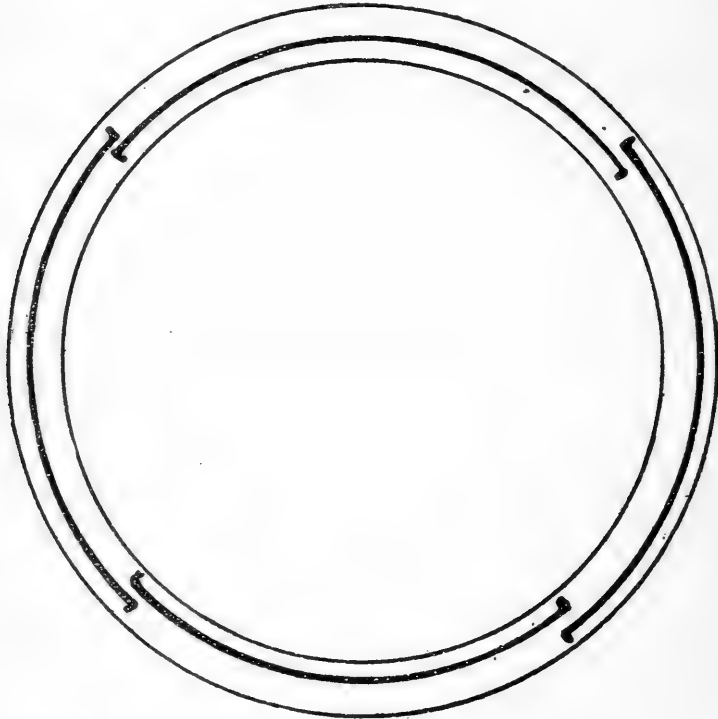

Fig. 21. *Showing method of bedding iron rods in stone, brick, or concrete walls, to increase the strength.*

Flat quarry rock, like limestone, will make the strongest silo wall, because they bond much better than boulders do, and when built of limestone they will not need to be reinforced much with iron rods. It will be best even in this case, however, to use the iron tie rods between the lower two doors. (King.)

Brick Silos.—In constructing a brick silo it will be well to guard the following points; Make the foundation of stone if practicable, and let the first course of brick come flush on the inside with the stone work. Bed a five-eighths inch iron hoop in the stone work in the upper part before laying the brick, in order to keep the pressure of brick from spreading the wall before the mortar becomes set and hard. Make a two-inch air space in the walls up to within one-third of the top. This will make a 14-inch wall of three courses of brick. If, however, the silo is to be over 24 feet inside diameter, then a four-brick wall is really necessary one-third the way up, then the next third of three bricks and the last third of two bricks. The air space should be in the outer part of the wall. Iron tie rods should also be laid around in the wall between the doors, as recommended in the stone work. It is also important that the brick should be wet when laid, otherwise the mortar in which they are laid will be dried out too rapidly. The walls should be plastered over very smoothly with a coat of rich cement, one-fourth to one-half inch thick, and then every two or three years this should be well white-washed with thin cement, to keep the wall protected from the effects of acid in the silage. King recommends that the floor jambs be made of 3x6's or 3x8's, rabbetted two inches deep to receive the door on the inside. The center of the jambs outside should be grooved and a tongue inserted projecting three-fourths of an inch outward to set back into the mortar, and thus secure a thoroughly air-tight joint between wall and jamb. The doors may be made of two layers of matched flooring with tarred paper between, and lag screw bolted to the jamb, so as to give a perfect smooth face next to the silage.

Stone Silos.—The stone should have a wall about two feet thick below the surface of the ground, and this may be laid in the cheaper grades of cement. Above the surface a good grade of Portland cement should be used. A thickness of wall of 18 inches at the surface of the ground is desirable, but this may be gradually reduced

to 12 inches at the top, keeping the inner surface of the silo perpendicular. It is important to have five-eighths inch iron rods, with angles on the ends, laid in the wall at intervals between each door, to keep the walls from cracking or spreading before the mortar or cement is thoroughly set. These rods may be of several lengths, laid to the curve of the wall, and the angled ends should lap by each other for three or four inches.

It will be well to place silos a distance below the surface. This should not be deep enough on level land, however, to require great exertion to get out the silage. Under such circumstances four feet is deep enough. (Plumb.)

Details concerning the construction of stone, brick, and cement silos are given in Prof. Woll's Book on Silage, and in Bulletin No. 83 of Wisconsin Experiment Station, by Prof. King as well as in numerous other pamphlets, and we shall not take up further space here with the discussion thereof. The same holds true with all other forms of silo construction than those already explained, except the one kind, where silos are built in a bay of the barn. In order to use the space economically, these silos are built in a rectangular form.

Silos in the Barn.

A large number of silos have been built in the barn, especially in the early days of silo construction. Where the necessary depth can be obtained and where the room can be spared, such silos can be built very easily and at a less cost than a separate structure, since lighter materials in construction may be used in this case, and no roof will be required for the silo. Silos built in this manner have generally the advantage of being near at hand. Since feeding time comes twice a day, at least, throughout the winter and spring, a few steps saved in hauling the silage mean a good deal in the aggregate. Many farmers first made silos of this kind, and, later on, when familiar with the silage and siloing process, built additional separate structures.

A very cheap rectangular silo may be constructed by erecting strong 3x10 studding around a bay or part of a bay, and lining with one ply good matched lumber one-inch thick. Such a silo has been in use at the Ottawa Station for eight years, and has given good results.

The main objection to rectangular or square silos is that it is very difficult to make the corners perfectly tight, so that air will not enter at these points and cause more or less of the silage to spoil here. Even if carefully built, the lateral pressure in a silo filled with green fodder is often great enough to cause the boards to spring and thus let air in, unless special precautions have been taken to

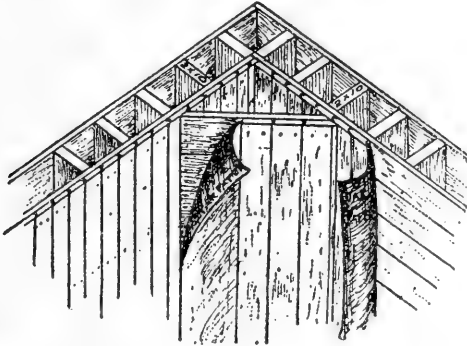

Fig. 23. *Corner of rectangular silo. (Whceler.)*

prevent it. One way of avoiding this difficulty is to partially round off the corners, by placing a square timber, split diagonally, in each of the corners. Another plan is to bevel the edge of a ten-inch plank and nail it in the corners, filling in behind with dry dirt or sand. Sawdust has been recommended, but should not be used, as it will draw moisture and cause the plank and silo lining to decay. The space back of the plank may also be left empty.

The arrangement for making the corners of a square or rectangular silo air-tight shown in Fig. 23 was published by the Geneva Experiment Station. The corners are boarded up, as shown in the figure, a sheeting of paper

going between the two courses of boards. The partitions at the corners can be put across after the first course of boards, instead of after the lining is in place, as shown in the illustration.

The silos of the form mentioned may be strengthened at the corners by the arrangement recommended by Prof. Spillman and shown in Fig. 24. Half-inch bolts are used

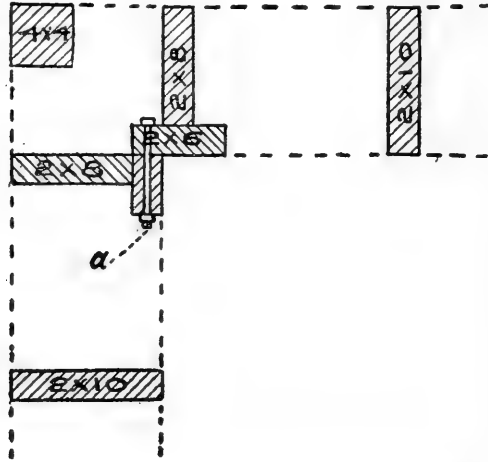

Fig. 24. Cross section of studding at the corner of a rectangular silo. (Spillman.)

to hold the 2x4 and 2x6 together. The bolts are not more than eighteen inches apart from the bottom up to about the middle of the studding. Above the middle they may be two feet apart; they may be reinforced by 30d. nails.

Octagonal Silos.

A number of octagonal silos have been built in recent years, and find favor with their owners in most instances. If properly put up and care taken to fasten the girts securely at the corners with plenty of spikes, the octagonal silo is greatly superior to the square type, and has nearly every advantage of the round silo, and can readily

be constructed by anyone handy with tools with the assistance of the ordinary farm help.

The foundation should be of stone or brick as described for various other forms of silos, and should be laid out with proper dimensions for the size decided upon. Brief details are here given for an octagonal silo of about the same capacity as a round silo, 20 feet in diameter and of equal height.

If the foundation is laid out so that the corners are in the circumference of a circle 21 feet in diameter the horizontal girts will be about 8 feet long, and will be much stronger and better able to withstand the lateral pressure than the sides of a square silo of equal capacity. Details of construction are shown in the drawings, Figs. 25 and 26. The girts should be 3x8 in. and spiked at the corners

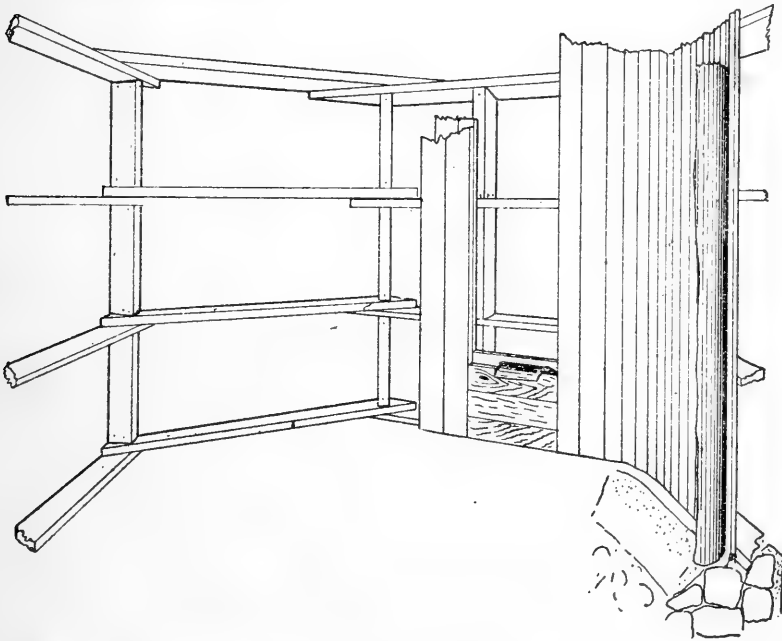

Fig. 25. *Perspective, showing construction of frame, and double lining with paper between. The door is made of two thicknesses with paper between, as shown.*

with 6 inch spikes, up to nearly one-half of the height of the silo, and 2x8 in. the rest of the way, fastened with 20 penny spikes. The girts should be 16 inches apart at the bottom for one-third of the height of the silo. They may be 18 inches apart the second third of the distance, and above that the distance between them can be increased till they are 2 feet or more at the very top. A double row may be used for a plate. Sound timber only should be used. Care should be taken to have the girts securely spiked at the corners, so that the joints will not give. The horizontal girt sections take the place of hoops in the round silo and must be strong. Not less than six or eight spikes should be used at each splice. One of the causes of failure in home-made silos of every kind is that the ordinary carpenter, who has probably never built a silo before, has but a limited idea of the pressure on the sides of a silo 30 or more feet deep, and does not realize the disappointment and loss occasioned by a poorly built silo.

A simple method of getting the walls perpendicular is to first lay the sill, which should be fastened to the wall securely, by means of bolts set in the wall, and then erect at each corner and on the inside a temporary post or scantling to serve as a guide, braced in position so that it is perpendicular both ways, and the girts then laid and spiked in position, one above the other.

The lining is, of course, put on up and down and should be matched and of good thickness, say $1\frac{1}{4}$ or $1\frac{1}{2}$ if but one layer is used. If two layers, it need not be so thick, $\frac{7}{8}$ -inch flooring, and the outer layer not necessarily matched. The corners should be fitted as nicely as possible, and it is a good plan to block out the corners, as shown at Fig. 26, a, a, a, so that the tongues and grooves can be properly adjusted to each other.

John Gould, a prominent dairy writer and lecturer, recommends, where one thickness of matched lumber is used in the above manner, that the lining be thoroughly coated on the outside with heavy application of coal tar, or other similar substance, so as to prevent the air pene-

trating the pores of the lumber, and causing the silage to dry on to the inner surface.

Any style of door can be used, but an effective continuous door is shown in the illustration. If any of the girts be cut out to make the door space larger, the remaining ones should be correspondingly reinforced.

The making of a roof for such a silo is a simple matter, and a dormer window will assist in filling, although

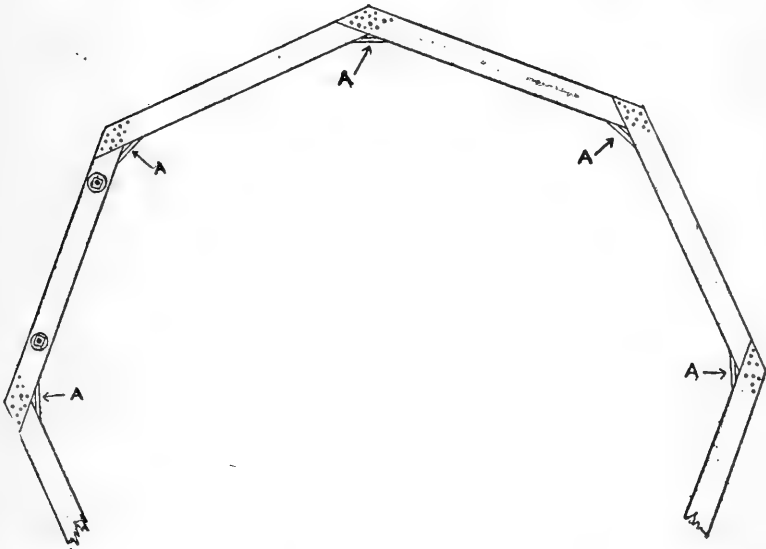

Fig. 26. Showing method of laying sill and bolting same to foundation for an octagonal silo.

a trap door may be used in case the filling be done with a blower. Any style of siding may be used.

Such a silo if well built will be durable, satisfactory, have nearly all the advantages of a round silo, and in addition will be a much more stable structure, requiring no tightening of the hoops from time to time.

Bills of materials for a silo built to 21-foot circle and 30 feet high are given below. The cost will, of course, vary with the locality.

Bills of materials for Octagonal Silo 20x30 feet outside measurement:

Foundation	10 perches
Girts110 feet 3x8) 8 or 16 foot 900 feet 2x8 { lengths.
Rafters	230 feet 2x4x14 feet
Siding	2500 feet
Lining	2800 feet 1¼ inch thick, matched
Dormer Window	
Nails and spikes	300 lbs.
Shingles	4 M
Paint	6 gallons

Cost of Different Kinds of Silos.

The cost of a silo will depend on local conditions as to price of labor and materials; how much labor has to be paid for; the size of the silo, etc. The comparative data for the cost of two round silos, 13 and 25 feet in diameter, and 30 feet deep, is given by Prof. King, as shown in the following table:

KINDS OF SILO.	13 FEET INSIDE DIAMETER.		25 FEET INSIDE DIAMETER.	
	Without roof.	With roof.	Without roof.	With roof.
Stone Silo	\$151	\$175	\$264	\$328
Brick Silo	243	273	437	494
Brick-lined Silo, 4 inches thick	142	239	310	442
Brick-lined, 2 inches thick	131	190	239	369
Lathed and plastered silo	133	135	244	363
Wood Silo with galvanized iron	168	135	308	432
Wood Silo with paper	123	222	235	353
Stave Silo	127	183	131	239
Cheapest wood Silo	101	144	195	240

During the spring of 1895 Prof. Woll made inquiries in regard to the cost of silos of different kinds (not only circular ones) built by farmers in different states in the

Union. The results of this inquiry are summarized briefly below.

The cheapest silos are those built in bays of barns, as would be expected, since roof and outside lining are here already at hand. Number of silos included, fourteen; average capacity, 140 tons; average cost of silos, \$92, or 65 cents per ton capacity.

Next comes the square or rectangular wooden silos. Number of silos included, twenty-five; average capacity, 194 tons; average cost of silos, \$285, or \$1.46 per ton capacity.

The round silos follow closely the square wooden ones in point of cost. Only seven silos were included, all but one of which were made of wood. Average capacity, 237 tons; average cost, \$368, or \$1.54 per ton capacity. The data for the six round wooden silos are as follows: Average capacity, 228 tons; average cost, \$340, or \$1.52 per ton capacity. The one round cement silo cost \$500, and had a capacity of 300 tons (dimensions: diameter, 30 feet; depth, 21 feet); cost per ton capacity, \$1.67.

The stone or cement silos are the most expensive in first cost, as is shown by the data obtained. Number of silos included, nine; average capacity, 288 tons; average cost, \$577, or \$1.93 per ton capacity.

The great difference in the cost of different silos of the same kind is apparent without much reflection. The range in cost per ton capacity in the 25 square wooden silos included in the preceding summary was from 70 cents to \$3.60. The former figures were obtained with a 144-ton silo, 20x18x20 feet; and the latter with a 140-ton silo, built as follows: Dimensions, 14x28x18 feet; 2x12x18 feet studs, set 12 inches apart; two thicknesses of dimension boards inside, with paper between, sheeting outside with paper nailed on studding; cement floor. Particulars are lacking as regards the construction of the first silo beyond its dimensions.

It may be in order to state, in comparing the average data for the cost of the different silo types, that the round

silos were uniformly built better than the rectangular wooden silos included, and according to modern requirements, while many of the latter were old and of comparatively cheap construction, so that the figures cannot be taken to represent the relative value of rectangular and round silos built equally well.

A good many figures entering into the preceding summaries are doubtless somewhat too low, if all labor put on the silo is to be paid for, for in some cases the cost of work done by the farmers themselves was not figured in with other expenses. As most farmers would do some of the work themselves, the figures given may, however, be taken to represent the cash outlay in building silos. In a general way, it may be said that a silo can be built in the bay of a barn for less than 75 cents per ton capacity; a round or a good square or rectangular wooden silo for about \$1.50, and a stone or cement silo for about \$2 per ton capacity, all figures being subject to variations according to local prices for labor and materials.

Rennie, a Canadian writer, gives the following comparative figures as to cost of silos: Round stave silos, 75 cents per ton capacity; round wooden silos, \$1.25 and cement silos, \$1.25 to \$1.50 per ton capacity.

The cost of stave silos will of course vary with the kind of lumber used, cost of labor, and other expenses, as in case of other types of silos. It is evident that stave silos can as a rule be built cheaper than other kinds of silos, both from the fact that less material is used in their construction, and because the labor bill is smaller. One of the first stave silos described, built in Ontario, Canada, cost \$75.00; capacity, 140 tons. Other and better built stave silos have been put up for \$100 for a 100-ton silo, and this may be considered an average price for such a silo, made of white pine, hemlock or any lumber that is cheapest in the particular locality where the silo is to be built. If built of Southern cypress, and complete with conical roof and doors, the price of stave silos will in the North come to about \$1.50 per ton capacity, small

silos being a little dearer, and larger ones a little cheaper than this average figure.

Estimating Material and Cost of Silos.

Several writers on silo construction have published bills of materials used in the construction of silos of moderate sizes of the following three types: Wisconsin Improved Silo, Modified Wisconsin Silo, and Stave Silo. Farmers contemplating building a silo, can use these estimates for figuring out the approximate cost of silos of the three kinds under his conditions as to cost of materials and labor. The estimates are made for silos built in the open, on level land. On hillsides deeper walls may be made to advantage, and where the silo is located within a building no roof will be needed. Consequently various factors may alter the applications of these estimates, which are only offered as suggestive, with the hope they may prove helpful. The first three estimates of materials are published by Prof. Plumb, while the others have been furnished by Professors King and Withycombe.

Estimate of Materials for Wisconsin Improved Silos.

Size, 30 feet deep, 14 feet diameter. Capacity 90 tons.

Brick—3375 for foundation, 1 foot thick, 3 feet deep.

Studs—50 pieces 2x4, 16 feet long.

Studs—50 pieces 2x4, 14 feet long.

Flooring for doors—32 feet, 4 matched.

Sheeting—3000 feet, $\frac{1}{2}$ inch, resawed from 2x6—16 foot plank sawed 3 times, dressed one side to uniform thickness for inside lining of two layers.

Lining—1500 feet of same for outside.

Tar building paper—200 yards, water and acid-proof.

Nails—200 lbs. 8-penny; 200 lbs. 10-penny.

Spikes—20 lbs.

Rafters—22, 2x4, 10 feet long, for usual ridge roof.

Sheeting for roof—350 feet of 16 foot boards.

Shingles—3000.

Shingle nails—12 lbs.

Dormer window for filling through. Paint—7 gallons, providing two coats.

Cement—2 barrels, for cementing bottom.

Estimate of Materials for a Modified Wisconsin Silo.

Same capacity as preceding.

Brick—350 for foundation, 8 in. wide, 5 in. thick.

Studs—50 pieces 2x4, 16 ft. long.

Studs—50 pieces 2x4, 14 ft. long.

Sheeting—3000 ft. $\frac{1}{2}$ in. resawed from 2x6, 16 ft. plank sawed three times, dressed to uniform thickness for inside lining of two layers.

Tar building paper—200 yards water and acid-proof.

Nails—150 lbs. 8 penny.

Spikes—12 lbs.

No outer siding, roof or floor is figured on or provided for in this construction.

Estimate of Materials for a Stave Silo.

Size 12x28 ft., capacity, 60 tons.

Bricks—1800 for foundation, 1 foot thick, 2 ft. deep.

Staves—77 2x6, 16 ft. dressed 4 sides.

Staves—77 2x6, 12 ft., dressed 4 sides.

Rods—10, 19 $\frac{1}{2}$ ft. long $\frac{1}{2}$ in. iron, with $\frac{5}{8}$ threaded ends and nuts.

Staples—2 gross, $\frac{1}{2}$ x2 in.

Iron tighteners—20 holding ends of hoops.

Rafters—2 2x6 pieces, 14 ft. long for roof center.

Rafters—2 2x6 pieces, 13 ft. long, for roof next center.

Side rafters—48 ft. 2x4 pieces.

Roof sheeting—170 ft. common.

Tin sheeting—196 ft.

Cement for floor—2 bbls.

Estimate of Materials for a Wisconsin Improved Silo.

Size 30 ft. deep, 20 ft. inside diameter, capacity 200 tons.

Stone foundation—7.5 perch.

Studs—2x4, 14 and 16 ft., 1,491 ft.

Rafters—2x4, 12 ft., 208 ft.

Roof boards—Fencing, 500 feet.

Shingles—6 M.

Siding—Rabbeted, 2,660 ft.

Lining—Fencing, ripped, 2,800 ft.

Tarred paper—740 lbs.

Coal tar—1 bbl.

Hardware—\$6.00.

Painting (60 cents per square) \$13.20.

Cementing bottom—\$5.00.

Carpenter labor—(at \$3 per M and board) \$33.17.

The estimated cost of the last silo is \$246.39; it is an outside, wholly independent structure, except connected with the barn in the manner shown in Fig. 20, with entrance and feeding chute toward the barn.

Estimate of Materials for Stave Silo.

12 ft. in diameter, 24 ft. deep, capacity, 49 tons.

1 2-3 yards of rock gravel.

4 barrels of sand.

1 barrel of cement.

2260 ft. tongued and grooved staves.

72 ft. 3x6, 24 ft. door frames.

358 ft. $\frac{5}{8}$ in. round iron for hoops and bolts, weight 465 lbs.

9 lugs.

54 nuts.

Preservative (\$1.50).

If the silo is constructed outside, materials for roof and painting are to be added to the preceding list.

Although most of the foregoing descriptions of stave

silos do not mention tongued and grooved staves, the latest practice indicates that, if properly done, it is a decided advantage to have the staves matched, also **slightly** beveled. The silo made in this manner will not be so liable to go to pieces when empty. This is the chief objection to the stave silo, and numerous cases are on record where stave silos standing in exposed places have blown over when empty. It is recommended, therefore, that stave silos be attached to the barn by means of a feeding chute, and in the case of high or exposed silos it is well to make use of guy rods or wires in addition. Indeed, some manufacturers of stave silos now recommend these on some of their silos, and make provisions for them.

Preservation of Silo.

A silo building will not remain sound for many years unless special precautions are taken to preserve it. This holds good of all kinds of silos, but more especially of wooden ones, since cement coating in a stone silo, even if only fairly well made, will better resist the action of the silage juices than the wood-work will be able to keep sound in the presence of moisture, high temperature, and an abundance of bacterial life.

In case of wooden silos it is necessary to apply some material which will render the wood impervious to water, and preserve it from decay. A great variety of preparations have been recommended and used for this purpose. Coal tar has been applied by a large number of farmers, and has been found effective and durable. It may be put on either hot, alone or mixed with resin, or dissolved in gasoline. If it is to be applied hot, some of the oil contained in the tar must previously be burnt off. The tar is poured into an iron kettle, a handful of straw is ignited and then thrown into the kettle, which will cause the oil to flash and burn off. The tar is sufficiently burnt when it will string out in fine threads, a foot or more in length, from a stick which has been thrust into the blazing kettle

and afterward plunged into cold water. The fire is then put out by placing a tight cover over the kettle. The kettle must be kept over the fire until the silo lining has been gone over. A mop or a small whisk broom cut short, so it is stiff, may serve for putting on the tar.

Coal tar and gasoline have also been used by many with good success. About half a gallon of coal tar and two-thirds of a gallon of gasoline are mixed at a time, stirring it while it is being put on. Since gasoline is highly inflammable, care must be taken not to have any fire around when this mixture is applied. Asbestos paint has also been recommended for the preservation of silo walls, and would seem to be well adapted for this purpose.

Many silos are preserved by application of a mixture of equal parts of boiled linseed oil and black oil, or one part of the former to two of the latter. This mixture, applied every other year, before filling time, seems to preserve the lining perfectly. In building round silos, it is recommended to paint the boards with hot coal tar, and placing the painted sides face to face.

Manufacturers of stave silos and fixtures put up special preparations for preserving the silos, which they send out with the staves. These are generally simple compounds similar to those given in the preceding, and are sold to customers at practically cost price.

Walls of wooden silos that have been preserved by one or the other of these methods will only keep sound and free from decay if the silos are built so as to insure good ventilation. Preservatives will not save a non-ventilated silo structure from decay.

Plastered wooden silos are preserved, as we have seen by applying a whitewash of pure cement as often as found necessary, which may be every two or three years. The same applies to stone and cement silos. The degree of moisture and acidity in the silage corn will doubtless determine how often the silo walls have to be gone over with a cement wash; a very acid silage, made from immature corn will be likely to soften the cement coating

sooner than so-called sweet silage made from nearly mature corn.

A considerable number of wood silos are in use that were not treated on the inside with any preservative or paint and have stood very well. Indeed, some writers maintain that if the silo is well protected on the outside, a stave silo receives little if any benefit from inside coatings.

CHAPTER VI.

CONCRETE OR CEMENT SILOS.

In the preceding chapter we have attempted to deal with wood, brick and stone in silo construction.

Of late years, however, a big demand has sprung up for a more substantial structure. This is evidenced by the large number of factory and other buildings springing up in all parts of the country made of concrete and cement blocks. This construction is getting to be very popular in so far as silos are concerned; especially is this true where permanency is desired, such as on established stock farms, etc.

Three forms of concrete silos are in successful use. They are known as the Monolithic Concrete Silos, both solid and hollow wall, and the Concrete Block Silos. In the extreme north, the hollow wall type should be chosen to prevent freezing; otherwise, the cost, fixed largely by local conditions, should be the deciding feature.

In the past the high first cost of these forms of construction has been the chief factor against their more extensive use, but this has been due to our insufficient knowledge as to the best and most economical methods in handling material. The price of lumber has been steadily rising, while that of good Portland Cement has been decreasing, and good qualities can now be obtained at a fair price; it seems, therefore, to be generally conceded that the concrete or cement block silo will be the silo of the future.

The chief advantages claimed for the concrete silos, when properly built, are that they are absolutely air-tight and water-tight, hence will neither shrink in hot, dry weather nor swell up in damp weather; that they maintain a more even temperature because concrete is a great

non-conductor of heat and cold; that the silage acids that affect wood and metal have no effect on concrete; that they are vermin proof; that they will last practically forever and need no repairs, and that they are fire proof.

The general concensus of opinion among those who have made a study of the matter seems to be well voiced in Bulletin No. 102 of the Agricultural Experiment Station of the University of Illinois when it says: "From what we know now the round wood silo plastered with cement seems to be the best construction, but the indications are that when we learn to handle concrete to the best advantage this will be the material for building silos."

The United States Government has, in every state in the Union, established Agricultural Experiment Stations for the purpose of giving the American farmer and American Agriculture in general the benefits of the best and most improved methods. Several of these stations have investigated the subject of silo construction and we feel that we cannot do better than quote some of their results. The station at the University of Wisconsin very clearly introduces the situation in their Bulletin No. 125 as follows:

"Cement is being more and more widely used in all kinds of construction work. It is not strange, therefore, that it is being tried in silo construction. Concrete has been used for a long time in silo foundations, but it is now being used in the superstructure also. As yet, however no careful work has been done to determine what is the best method to follow in construction of silos in concrete. Concrete in itself is very strong, much stronger than ordinary brick or stone masonry, that is, providing good cement is used and the concrete properly made.

"Reinforced concrete, or concrete steel, is very much stronger than ordinary concrete. Reinforced concrete is concrete in which steel rods or wires are imbedded in such a way as to take the strain. By placing wires or rods in the concrete it is possible to make the walls or beams much thinner or lighter than would otherwise be

possible and obtain the required strength. By reinforcing the concrete with steel much cement is saved. In Europe, and particularly in France, reinforced concrete has been very extensively used and used with much boldness. A simple instance will illustrate:

“A large elevator and mill in France was constructed wholly of reinforced concrete, walls, floors, beams, and posts. The mill is 112 feet high from foundation to roof. The roof is used as a reservoir holding 100 tons of water. The capacity of the elevator is 7,000 tons. The walls are only 12 inches thick at the foot and 4 inches at the top.

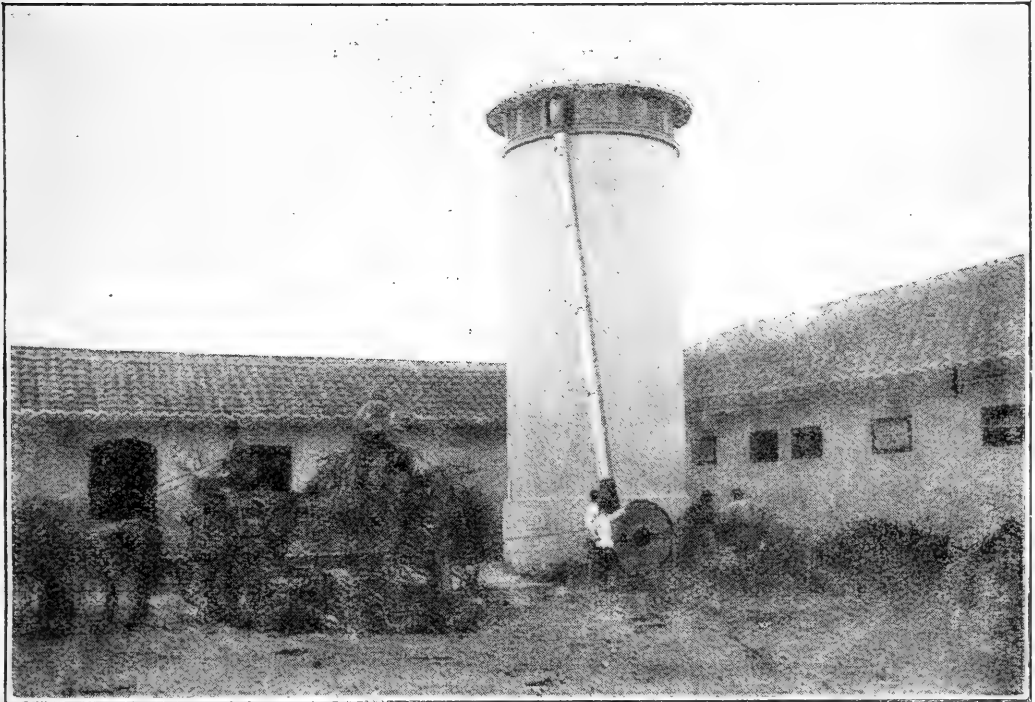

Fig. 28. Large cement silo and barns at Posto Zootechnico Central (Experiment Station) at Sao Paulo, Brazil, South America. Silo being filled with No. 17 Ohio Blower Machine.

“To obtain best results in concrete it is necessary first to use good cement, and, second, the work must be carefully and skillfully done. This is particularly true of reinforced concrete. The mixing of the concrete requires skill as well as does the tamping of the concrete in the forms. The proportion of sand to mix with the gravel or crushed stone will vary somewhat with the character of the gravel and the sand and it requires experience to know just the right proportions to use. The proportion of cement to sand will vary with the cement and with the sand. This again involves skill. The amount of water to use will vary considerably with circumstances. If the cement is too wet or too dry best results will not be obtained. Experience and skill are again involved here.

“If it were possible to have the work skillfully done a cement silo 16 feet in diameter and 35 feet high could be built of reinforced concrete with walls only 2 or 3 inches thick and be abundantly strong. But labor sufficiently skilled to do this would cost too much, so that it would be cheaper to use twice as much cement; make wall 6 or 8 inches thick and use less skilled labor. If the work is carefully done using ordinary labor it is practicable to build silos 16 feet in diameter and 35 feet high with 6 or 8 inch walls if the steel rod is laid in the wall every 2 or 3 feet.”

Reinforced concrete offers great possibilities for silo building. The lateral pressure on the walls when the silo is filled is very great, but the circular shape renders it very easy to reinforce. The freezing of the silage has heretofore been the one disadvantage of solid walls, especially in cold climates, but this has been largely overcome by machines now on the market that easily and successfully build reinforced and continuous hollow walls. (See pages 165 and 166 for special articles on frozen silage.)

The foundation, as in all other concrete structures, is very important. Not only must it serve as an anchor to protect the structure against wind pressure, but it must also be very strong and firm or the great weight upon it

will cause it to settle unevenly, in which event the walls are liable to crack and so admit air; consequently, spoiled silage will be the result.

The Missouri State Board of Agriculture in its March, 1906, bulletin describes a concrete silo built by Mr. C. J. W. Jones, Roanoke, Mo., in the summer of 1905, as follows: "It is 16 by 40 feet inside measurement, it being 9 feet in the ground. He first dug the hole and leveled the bottom. Then started the inside form, which was made of old pieces of fence boards stood on end around the circle and held in place by thin limber boards tacked onto them. He also had a center pole to guide by and brace to. The bottom wall was made thick and tamped against the earth bank. When the level of the ground was reached he carefully leveled up the work and started the outside form, which was made of a band of iron, 20 inches wide and 53.43 feet long, rolled to form the circle and was fastened with clamps at the ends. The silo being 16 feet in diameter and the walls 6 inches thick, the form is then 17 feet in diameter. This was leveled and the space between it and the inner wall of boards filled with concrete and tamped. When this hardened the form was loosened, raised and screwed tight again after getting it level; the space again filled and so on to the top. The inner wall was raised as needed, being braced against the center pole from all sides."

The wall was reinforced to prevent cracking by building a wire rope into it every few feet. The door frames were built into the wall while it was being made. The material for the silo cost about \$150.00.

We quote from Bulletin No. 125 of the Wisconsin station:

"A common type of form used in making a continuous wall or monolithic structure is illustrated in Fig. 41. A is the outside form and B the inside form. These forms are made as segments of the circle 6 or 10 feet in length and $1\frac{1}{2}$ to 3 feet deep. A form is made by taking two pieces of plank 2x12 or 2x14, LL and UU, Fig. 41 A, sawing them

out to the curvature of the circle. These are placed horizontally as girts and the short planks P are set vertically nailing them to the girts, LU. The form 41 B is made in the reverse of 41 A.

“In building the wall, form B is set inside of form A and 6 to 12 inches from it depending on the thickness desired for the wall, and the concrete is filled in between the forms.”

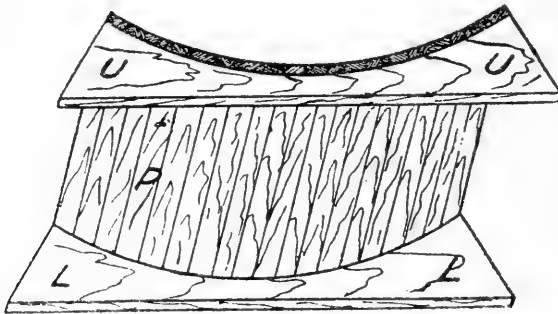

A Outside Form

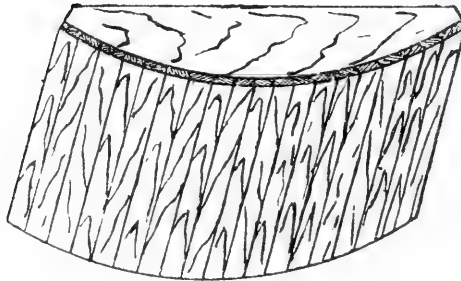

B. Inside Form

Fig. 41. Illustrates method of making form for constructing concrete walls. The forms are made of plank and are made in sections 4 to 10 feet long, requiring 5 to 8 sections to complete the circle.

—Courtesy Wisconsin Experiment Station.

Cement Blocks.

Continuing, the Bulletin just mentioned has the following regarding cement block silos:

Cement blocks are now made in a great variety of forms and these are being used to some extent in silo construction. Walls built of cement blocks, however, are not so strong as are walls in which the concrete is built in place, making what is known as a monolithic structure. When cement blocks are used it is necessary to use bands or rods in the wall laying them between the courses the same as in the stone or brick construction.

Cement blocks to be used in silo construction are usually made with curved sides, the curvature being that of the silo in question. A common type of block for this purpose is illustrated in Fig. 39. The blocks are made hollow, holes being left at H and H. The blocks are made with a dovetailed tenon at one end, as at T, and a dovetailed mortise at the other end, as at M, so that when the blocks are laid on the wall they interlock. The blocks are sometimes made with a small groove near the outside edge as G, G, and on every third or fourth course a small

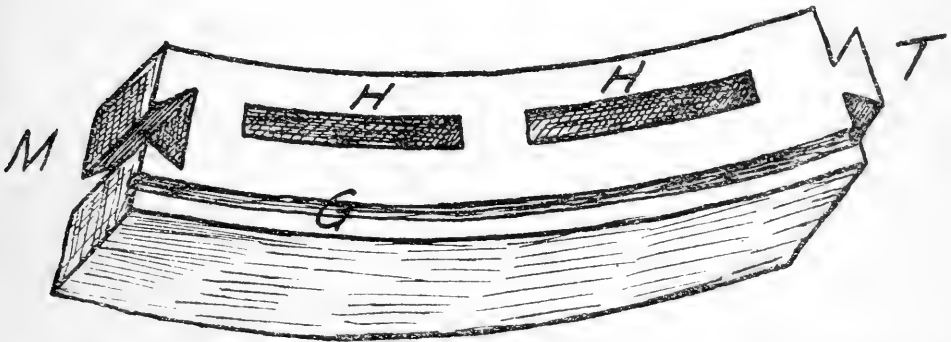

Fig. 39. Illustrates a type of concrete block used in silo construction. H. H. are holes left in blocks. T. and M. are dove-tailed tenon and mortise so made that blocks interlock when laid on the wall. G. is a groove made in block to imbed iron rod for reinforcing the wall.

—Courtesy Wisconsin Experiment Station.

rod ($\frac{1}{2}$ -inch iron) is laid in this groove and embedded in the masonry.

The cement block walls can be built more cheaply than can the monolithic walls, providing the building is not more than a mile or two from the factory where the blocks are made, and in some instances the manufacturers will move out their forms, mixers and other utensils for making cement blocks and make the blocks at the building site and still build more cheaply than the monolith can be built. It is possible to do this because the work can be done with greater facility on the ground level than up in the air on scaffolding. Cement blocks are turned out rapidly in a factory where all the facilities are at hand.

Cement blocks are usually made of finer materials than are the solid monolithic walls. The blocks are made of sand and cement; or if any gravel is used, it is very fine gravel, whereas, in the continuous wall, monolithic construction, coarser gravel or crushed stone is more commonly used. This is one of the reasons why the monolithic wall is stronger than the block wall.

The continuous wall may be made with holes or spaces the same as the holes H, H, in the block, Fig. 39. This is

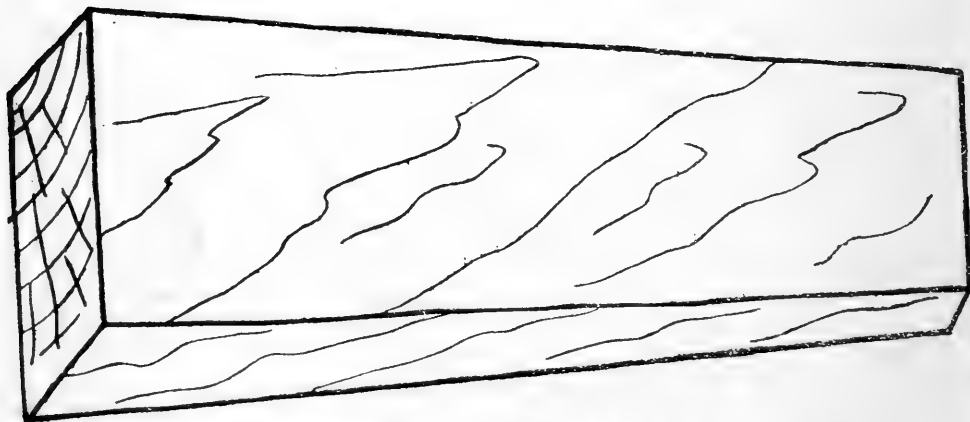

Fig. 40. Illustrates a tapering wood block used in making hollow concrete walls.—Courtesy Wisconsin Experiment Station.

accomplished by using short pieces of plank with smooth sides tapering toward one end, as shown in Fig. 40. These tapering wood blocks are set in the forms two or three inches apart near the center of the wall and the concrete filled in around them. After the first "set," that is, after a few hours the tapering blocks are drawn out leaving the hollow walls and the forms are raised the next day or the day following and the process repeated."

To Maintain the Cement Lining.—The Cement Lining or the Cement Block, if not properly cared for, is certain to become porous or to crack, due to the action of the acids in the silage. All such linings should be treated to a wash of cement once about every two years. A good wash is made by mixing Portland Cement with water, making the mixture the consistency of white wash, and applying it with a white wash brush or spray pump, mixing only a gallon or two at a time and applying it at once.

When filling the silo, it has been recommended to use plenty of water around the edges next to the wall.

Fig. 42 illustrates a cement block silo built by Mr. Alfred S. Dunlap, Centre, Ralls County, Mo. It is 16x32 feet inside and extends 18 inches into the ground. Writing to the Missouri State Board of Agriculture he says: "The blocks are 6x6 inches by 2 feet long. Used 200 sacks of Portland or Atlas brand cement in the foundation and blocks. 1400 blocks were required to build it. Just what the cost was I do not know, as my farm help worked at making the blocks, commencing in the spring, and working at odd times. It, perhaps, cost \$275.00, but I did not haul my sand and gravel more than 100 rods. I used a No. 14 cutter and a 10 horse-power traction engine, and did the work of cutting to my entire satisfaction. We worked three days and filled it about two-thirds full, and filled with corn grown on bottom lands and very heavy."

Mr. J. O. Bailey, Kirksville, Mo., writing to the same Board of Agriculture gives an instructive description of the building of his 16x32 silo.

"I made the blocks myself—size 8 by 8 by 24 inches,

curved enough so that 25 of them would lay a complete circle, 16 feet in diameter in the clear. Proportioned the cement and sand 1 to 5, i. e., 1 part cement to 5 parts sand. It took about 50 yards of sand and 205 sacks of cement. I also laid a No. 9 wire between each layer of

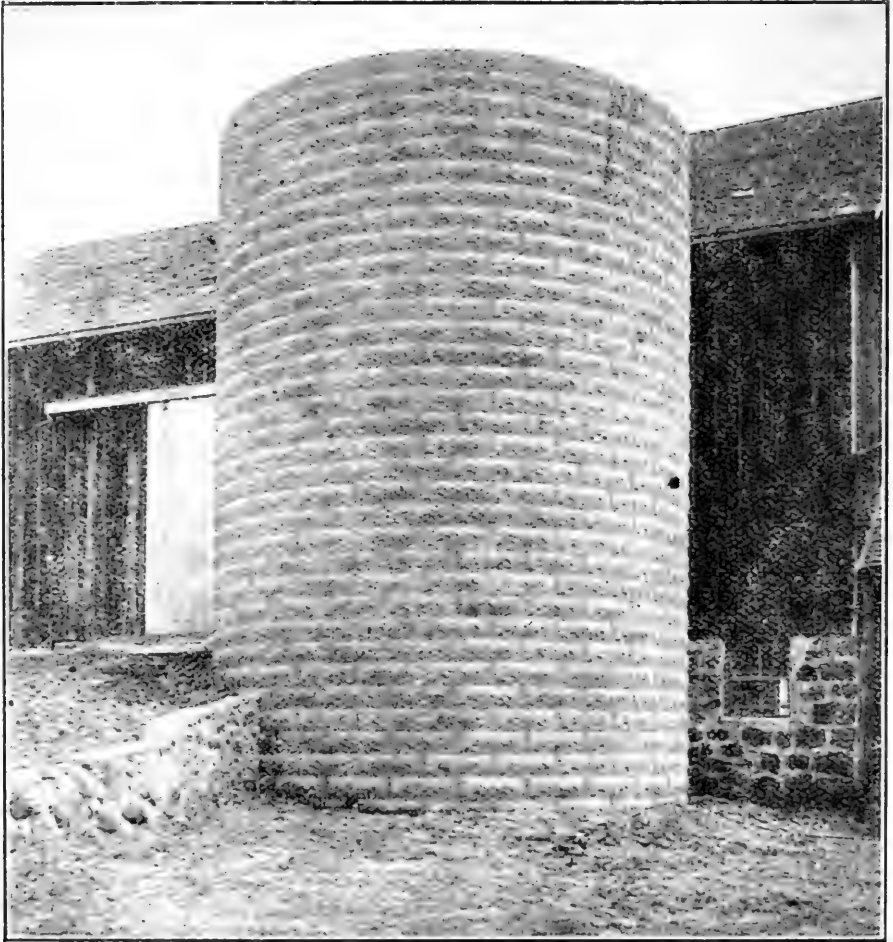

Fig. 42. *Cement block silo. The kind built by Mr. Dunlap of Centre, Ralls county, Mo.—Courtesy Hoard's Dairyman.*

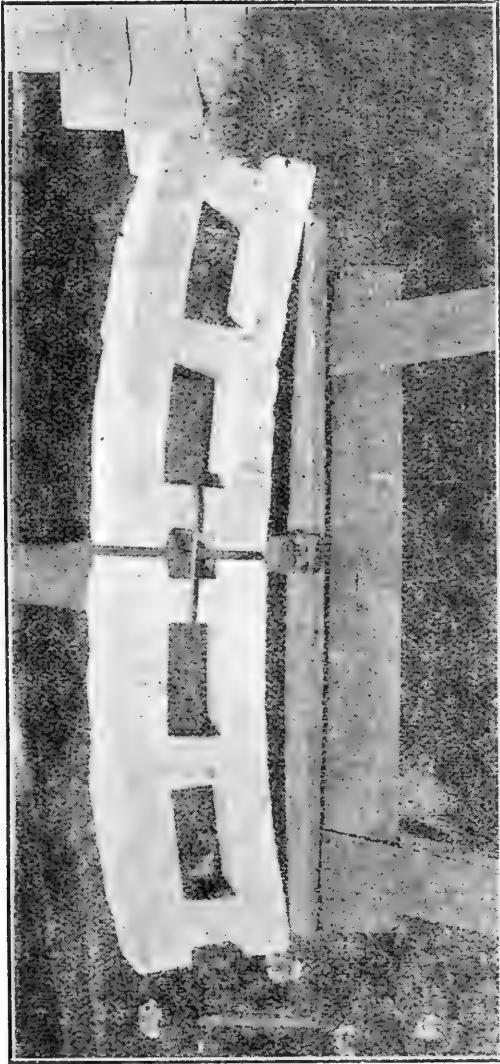

Fig. 43. Form of block used in the silo. Note the manner of reinforcing the blocks by means of $\frac{3}{8}$ iron binders. The hollow blocks require less material than the solid ones, and will not freeze so readily.

—Courtesy Hoard's Dairyman.

blocks up twenty feet. I don't think now it is really necessary to use the wire.

"I had a mason to superintend making of the blocks, but any one with average intelligence can make the blocks as good as a mason. The main thing is to get sand and cement thoroughly mixed. It does not want to be too wet, just moist enough to pack good in the mold. After the blocks have been made half a day or so they should be wet every day; this keeps them from drying too fast and from cracking.

"I hired a mason to lay up the blocks; this is the only skillful work about it, they have got to be laid up true. I did not cement inside of silo. My silage spoiled some around the outside. This is due to lack of moisture in the silage and also in the wall. I should have wet the silage and wall as the silo was filled, but was not fixed to do this.

"My silo is built $3\frac{1}{2}$ feet below the surface and in the last 4 or 5 feet of silage there was not a forkful spoiled.

"Two men can make 90 to 100 blocks a day after they become accustomed to it, I used a wood mold which any carpenter can make and will not cost over \$1 or \$1.50, at most.

"Now as to the doors. I used 2x6 plank for the jambs and set them flush with the outside of the wall; as the blocks are 8 inches thick there are two inches on inside for door to set in. The doors are ship-lap double with a good quality of tar paper in between, also a layer of tar paper on the side that sets against the jamb. The doors are 2 feet square and every 4 feet. Total cost about \$225.00. The cost for labor to fill it I estimate at \$50.00."

"This is a cost of nearly \$2.00 per ton capacity, but inasmuch as it will last a great many years it may be the cheapest kind in the long run."

CHAPTER VII.

SILAGE CROPS.

Indian Corn.—Indian corn is, as has already been stated, the main silage crop in this country, and is likely to always remain so. Before explaining the filling of the silo and the making of silage, it will be well, therefore, to state briefly the main conditions which govern the production of a large crop of corn for the silo, and to examine which varieties of corn are best adapted for silage making.

Soils best adapted to corn culture and preparation of land.—The soils best adapted to the culture of Indian corn are well-drained medium soils, loams or sandy loams, in a good state of fertility. Corn will give best results coming after clover. The preparation of the land for growing corn is the same whether ear corn or forage is the object. Fall plowing is practiced by many successful corn growers. The seed is planted on carefully prepared ground at such a time as convenient and advisable. Other things being equal, the earlier the planting the better, after the danger of frost is ordinarily over. "The early crop may fail, but the late crop is almost sure to fail." After planting, the soil should be kept pulverized and thoroughly cultivated. Shallow cultivation will ordinarily give better results than deep cultivation, as the former method suffices to destroy the weeds and to preserve the soil moisture, which are the essential points sought in cultivating crops. The cultivation should be no more frequent than is necessary for the complete eradication of weeds. It has been found that the yield of corn may be decreased by too frequent, as well as by insufficient cultivation. The general rule may be given to cultivate as often, but no oftener, than is necessary to kill the weeds, or keep the soil pulverized.

The cultivator may be started to advantage as soon as the young plants break through the surface, and the soil kept stirred and weeds destroyed, until cultivation is no longer practicable.

Varieties of corn for the silo.—The best corn for the silo, in any locality, is that variety which will be reasonably sure to mature before frost, and which produces a large amount of foliage and ears. The best varieties for the New England States, are the Leaming, Sanford, and Flint corn; for the Middle States, Leaming, White and Yellow Dent; in the Central and Western States, the Leaming, Sanford, Flint and White Dent will be apt to give the best results, while in the South, the Southern Horse Tooth, Mosby Prolific, and other large dent corns are preferred.

For Canada, Rennie gives, as the varieties best adapted for the silo; for Northern Ontario, North Dakota and Compton's Early Flint; for Central Ontario, larger and heavier-yielding varieties may be grown, viz., Mammoth Cuban and Wisconsin Earliest White Dent. It is useless to grow a variety for silage which will not be in a firm dough state by the time the first frosts are likely to appear.

In the early stages of siloing corn in this country, the effort was to obtain an immense yield of fodder per acre, no matter whether the corn ripened or not. Large yields were doubtless, often obtained with these big varieties, although it is uncertain that the actual yields ever came up to the claims made. Bailey's Mammoth Ensilage Corn, "if planted upon good corn land, in good condition, well matured, with proper cultivation," was guaranteed to produce from forty to seventy-five tons of green fodder to the acre, "just right for ensilage." We now know that the immense Southern varieties of corn, when grown to an immature stage, as must necessarily be the case in Northern States, may contain less than ten per cent. of dry matter, the rest (more than nine-tenths of the total weight) being made up of water. This is certainly a re-

markable fact, when we remember that skim-milk, even when obtained by the separator process will contain nearly ten per cent. of solid matter.

In speaking of corn intended to be cut for forage at an immature stage, Prof. Robertson, of Canada, said at a Wisconsin Farmers' Institute, "Fodder corn sowed broadcast does not meet the needs of milking cows. Such a fodder is mainly a device of a thoughtless farmer to fool his cows into believing that they have been fed, when they have only been filled up." The same applies with equal strength to the use of large, immature Southern varieties of fodder, or for the silo, in Northern States.

In comparative variety tests with corn in the North, Southern varieties have usually been found to furnish larger quantities per acre of both green fodder and total dry matter in the fodder, than the smaller Northern varieties. As an average of seven culture trials, Professor Jordan thus obtained the following results at the Maine Station.

COMPARATIVE YIELDS OF SOUTHERN CORN AND MAINE FIELD CORN GROWN IN MAINE, 1888-1893.

	SOUTHERN CORN.					MAINE FIELD CORN.				
	Green Fodder.	Dry Substance.		Digestible Matter.		Green Fodder.	Dry Substance.		Digestible Matter.	
		Per Cent.	Lbs.	Per Cent.	Lbs.		Per Cent.	Lbs.	Per Cent.	Lbs.
Maximum	46,340	16.58	6,237	69	3,923	29,400	25.43	7,064	78	4,945
Minimum	26,295	12.30	3,234	61	2,102	14,212	13.55	2,415	70	1,715
Average..	34,761	14.50	5,036	65	3,251	22,269	18.75	4,224	72	3,076

The average percentage digestibility of the dry substance is 65 per cent. for the Southern corn, and 72 per cent. for the Maine field corn, all the results obtained for the former varieties being lower than those obtained for the latter. While the general result for the five years, so far as the yield of digestible matter is concerned, is

slightly in favor of the Southern varieties, the fact should not be lost sight of that an average of $6\frac{1}{4}$ tons more of material has annually to be handled over several times, in case of these varieties of corn, in order to gain 175 pounds more of digestible matter per acre; we therefore, conclude that the smaller, less watery, variety of corn really proved the more profitable.

At other Northern stations similar results, or results more favorable to the Northern varieties, have been obtained, showing that the modern practice of growing only such corn for the silo as will mature in the particular locality of each farmer, is borne out by the results of careful culture tests.

Time of cutting corn for the silo.—In order to determine at what stage of growth corn had better be cut when intended for the silo, it is necessary to ascertain the amount of food materials which the corn plant contains at the different stages, and the proportion of different ingredients at each stage. From careful and exhaustive studies of the changes occurring in the composition of the corn plant, which have been conducted both in this country and abroad, we know that as corn approaches maturity the nitrogenous or flesh-forming substances decrease in proportion to the other components, while the non-nitrogenous components, especially starch (see Glossary), increase very markedly; this increase continues until the crop is nearly mature, so long as the leaves are still green. Several experiment stations have made investigations in regard to this point. As an illustration we give below data obtained by Prof. Ladd, in an investigation in which fodder corn was cut and analyzed at five different stages of growth, from full tasseling to maturity.

The data given below show how rapidly the yield of food materials increases with the advancing age of the corn, and also that increase during the later stages of growth comes largely on the nitrogen-fed extract (starch, sugar, etc.).

CHEMICAL CHANGES IN THE CORN CROP.

YIELD PER ACRE.	Tas- seled, July 30	Silked, Aug. 9	Milk, Aug. 21	Glazed, Sept. 7	Ripe, Sept. 23
	Pounds	Pounds	Pounds	Pounds	Pounds
Gross Weight.....	18045	25745	32600	32295	28460
Water in the Crop.....	16426	22666	21957	25093	20542
Dry Matter.....	2619	3078	4643	7202	7918
Ash.....	138.9	201.3	232.2	302.5	364.2
Crude Protein.....	239.8	436.8	478.7	643.9	677.8
Crude Fiber.....	514.2	872.9	1262.0	2755.9	1734.0
Nitrogen-free Extract (starch, sugar, etc.)	653.9	1399.3	2441.3	3239.8	4827.6
Crude Fat.....	72.2	167.8	228.9	260.0	314.3

The results as to this point obtained at several experiment stations have been summarized and are given in the following table, showing the increase in food ingredients during the stages previous to maturity.

We thus find that the largest amount of food materials in the corn crop is not obtained until the corn is well ripened. When a corn plant has reached its total growth in height it has, as shown by results given in the last table, attained only one-third to one-half of the weight of dry matter it will gain if left to maturity; hence we see the wisdom of postponing cutting the corn for the silo, as in general for forage purposes until rather late in the season, when it can be done without danger of frost.

The table given in the preceding, and our discussion so far, have taken into account only the total, and not the digestible components of the corn.

It has been found through careful digestion trials that older plants are somewhat less digestible than young plants. There is, however, no such difference in the digestibility of the total dry matter or its components as is found in the total quantities obtained from plants at the different stages of growth, and the total yields of

digestible matter in the corn will therefore be greater at maturity, or directly before this time, than at any earlier stage of growth. Hence we find that the general practice of cutting corn for the silo at the time when the corn is in the roasting-ear stage, when the kernels have become rather firm, and are dented or beginning to glaze, is good science and in accord with our best knowledge on the subject.

INCREASE IN FOOD INGREDIENTS FROM TASSELING
TO MATURITY.

EXPERIMENT STATION.	Variety.	Stage of Maturity.		Gain in per cent. between first and last cutting.			
		First Cutting.	Last Cutting.	Dry Matr.	Crude Protein	Crude Fat.	Carbo- Hyd's.
Cornell, N. Y.	Pride of the North	Bloom	Mature	150	90	129	169
" " "	Pride of the North	"	Nearly mature	217	134	374	300
Geneva, N. Y.	King Philip	Tasseled	Mature	389	183	335	462
New Hamp.	Av. of 4 var.	"	Glazed	112	50	84	130
Pennsylvania	Av. of 10 var.	"	Mature	155			
Vermont	Av. of 2 var.	"	Glazed	122	50		
"	" " " "	Bloom	"	204	81		
Average of all trials.....				193	98	230	265

Other reasons why cutting at a late period of growth is preferable in siloing corn are found in the fact that the quality of the silage made from such corn is much better than that obtained from green immature corn, and in the fact that the sugar is most abundant in the corn plant in the early stages of ear development, but the loss of non-nitrogenous components in the silo falls first of all on the sugar, hence it is the best policy to postpone cutting until the grain is full-sized and the sugar has largely been changed to starch.

It does not do, however, as related under Uniformity

in the first chapter to delay the cutting so long that the corn plant becomes too dry, for the reason stated. Silage does not spoil when too wet, but will mold if too dry. Experience will be the best guide, but the foregoing pages should enable the reader to form the right idea as to time for filling, which to secure the best results, is nearly as important as to have material with which to fill the silo.

Methods of Planting Corn. When the corn crop is intended for the silo, it should be planted somewhat closer than is ordinarily the case when the production of a large crop of ear corn is the primary object sought. Thin seeding favors the development of well-developed, strong plants, but not the production of a large amount of green forage. The number of plants which can be brought to perfect development on a certain piece of land depends upon the state of fertility of the land, the character of the season, especially whether it is a wet or dry season, as well as other factors, hence no absolute rule can be given as to the best thickness of planting corn for the silo. Numerous experiments conducted in different parts of the country have shown, however, that the largest quantities of green fodder per acre can ordinarily be obtained by planting the corn in hills three or even two feet apart, or in drills three or four feet apart, with plants six or eight inches apart in the row.

It makes little if any difference, so far as the yield obtained is concerned, whether the corn is planted in hills or in drills, when the land is kept free from weeds in both cases, but it facilitates the cutting considerably to plant the corn in drills if this is done by means of a corn harvester or sled cutter, as is now generally the case. The yield seems more dependent on the number of plants grown on a certain area of land than on the arrangement of planting the corn. Hills four feet each way, with four stalks to the hill, will thus usually give about the same yield as hills two feet apart, with stalks two stalks to the hill or drills four feet apart with stalks

one foot apart in the row, etc. The question of planting corn in hills or in drills is therefore largely one of greater or less labor in keeping the land free from weeds by the two methods. This will depend on the character of the land; where the land is uneven, and check-rowing of the corn difficult, or when the land is free from weeds, drill planting is preferable, while, conversely, on fields where this can be done, the corn may more easily and cheaply be kept free from weeds if planted in hills and check-rowed. Since one of the advantages of the silo is economical production and preservation of a good quality of feed, the economy and certainty in caring for the growing crop is of considerable importance, and generally planting in hills not too far apart will be found to facilitate this, especially during wet season.

Corn is planted in hills or in drills, and not broadcast, whether intended for the silo, or for production of ear corn; when sown broadcast, the corn cannot be kept free from weeds, except by hand labor. More seed is moreover required, the plants shade each other and will therefore not reach full development, from lack of sufficient sunshine and moisture, and a less amount of available food constituents per acre will be produced.

Other Silage Crops.

Clover. Clover is second to Indian corn in importance as a silage crop. We are but beginning to appreciate the value of clover in modern agriculture. It has been shown that the legumes, the family to which clover belongs, are the only common forage plants able to convert the free nitrogen of the air into compounds that may be utilized for the nutrition of animals. Clover and other legumes, therefore, draw largely on the air for the most expensive and valuable fertilizing ingredient, nitrogen, and for this reason, as well as on account of their deep roots, which bring fertilizing elements up near the surface, they enrich the land upon which they grow. Being a more

nitrogenous food than corn or the grasses, clover supplies a good deal of the protein compounds required by farm animals for the maintenance of their bodies and for the production of milk, wool or meat. By feeding clover, a smaller purchase of high-priced concentrated feed stuffs, like flour-mill or oil-mill refuse products, is therefore rendered necessary than when corn is fed; on account of its high fertilizing value it furthermore enables the farmer feeding it to maintain the fertility of his land.

When properly made, clover silage is an ideal feed for nearly all kinds of stock. Aside from its higher protein contents it has an advantage over corn silage in point of lower cost of production. A Wisconsin dairy farmer who has siloed large quantities of clover estimates the cost of one ton of clover silage at 70 cents to \$1, against \$1 to \$1.25 per ton of corn silage. His average yield per acre of green clover is about twelve tons.

Clover silage is superior to clover hay on account of its succulence and greater palatability, as well as its higher feeding value. The last-mentioned point is mainly due to the fact that all the parts of the clover plant are preserved in the silo, with a small unavoidable loss in fermentation, while in hay-making, leaves and tender parts, which contain about two-thirds of the protein compounds, are often largely lost by abrasion.

Clover may easily and cheaply be placed in a modern silo and preserved in a perfect condition. The failures reported in the early stages of silo filling were largely due to the faulty construction of the silo. Clover does not pack as well as the heavy green corn, and therefore, requires to be cut and weighted, or calls for greater depth in the silo, in order that the air may be sufficiently excluded.

When to Cut Clover for the Silo.—The yield of food materials obtained from clover at different stages of growth has been studied by a number of scientists. The following table giving the results of an investigation conducted by Professor Atwater will show the total quan-

tities of food materials secured at four different stages of growth of red clover.

YIELD PER ACRE OF RED CLOVER—IN POUNDS.

STAGE OF CUTTING.	Green Weight	Dry Matter	Crude Protein	Crude Fiber.	N-free Extract	Crude Fat.	Ash.
Just before bloom	3,570	1,385	198	384	664	24	115
Full bloom	2,650	1,401	189	390	682	33	107
Nearly out of bloom . . .	4,960	1,750	230	523	837	31	129
Nearly ripe	3,910	1,523	158	484	746	36	99

Professor Hunt obtained 3,600 pounds of hay per acre from clover cut in full bloom, and 3,260 pounds when three-fourths of the heads were dead. The yields of dry matter in the two cases were 2,526 pounds, and 2,427 pounds respectively. All components, except crude fibre (see Glossary), yielded less per acre in the second cutting. Jordan found the same result, comparing the yields and composition of clover cut when in bloom, some heads dead, and heads all dead, the earliest cutting giving the maximum yield of dry matter, and of all components except crude fibre.

The common practice of farmers is to cut clover for the silo when in full bloom, or when the first single heads are beginning to wilt, that is, when right for hay-making, and we notice that the teachings of the investigations made are in conformity with this practice.

Many farmers are increasing the value of their corn silage by the addition of clover. A load of clover to a load or two loads of well-matured corn is a good mixture.

Alfalfa (lucerne) is the great, coarse forage plant of the West, and during late years, it has been grown considerably in the Northern and Central States. In irrigated districts it will yield more food materials per acre of land than perhaps any other crop. Four to five cuttings, each yielding a ton to a ton and a half of hay, are common in

these regions, and the yields obtained are often much higher. In humid regions three cuttings may ordinarily be obtained, each of one to one and a half tons of hay.

While the large bulk of the crop is cured as hay, alfalfa is also of considerable importance as a silage crop in dairy sections of the Western States. As with red clover, reports of failure in siloing alfalfa are on record, but first-class alfalfa silage can be readily made in deep, modern silos, when the crop is cut when in full bloom, and the plants are not allowed to wilt much before being run through a cutter and siloed. In the opinion of the dairymen who have had large experience in siloing alfalfa, sweet alfalfa silage is more easily made than good alfalfa hay.

What has been said in regard to the siloing of clover refers to alfalfa as well. Alfalfa silage compares favorably with clover silage, both in chemical composition and in feeding value. It is richer in flesh-forming substances (protein) than clover silage, or any other kind of silage, and makes a most valuable feed for farm animals, especially young stock and dairy cows.

Cow Peas are to the South what alfalfa is to the West, and when properly handled make excellent and most valuable silage. The cow peas are sown early in the season, either broadcast, about $1\frac{1}{2}$ bushels to the acre and turned under with a one-horse turning plow, or drilled in rows about two feet apart. They are cut with a mower when one-half or more of the peas on the vines are fully ripe, and are immediately raked in windrows and hauled to the silo, where they are run through a feed cutter and cut into inch lengths.

Cow pea silage is greatly relished by farm animals after they once become accustomed to its peculiar flavor; farmers who have had considerable practical experience in feeding this silage are of the opinion that cow-pea silage has no equal for cows and sheep. It is also a good hog food, and for all these animals is considered greatly superior to pea-vine hay. In feeding experiments at a

Delaware experiment station six pounds of pea-vine silage fully took the place of one pound of wheat bran, and the product of one acre was found equivalent to two tons of bran.

Instead of placing only cow peas in the silo, alternate loads of cow peas and corn may be cut and filled into the silo, which will make a very satisfactory mixed silage. A modification of this practice is known as **Getty's method**, in which corn and cow peas are grown in alternate rows, and harvested together with a corn harvester. Corn for this combination crop is preferably a large Southern variety, drilled in rows $4\frac{1}{2}$ feet apart, with stalks 9 to 16 inches apart in the row. Whippoorwill peas are planted in drills close to the rows of corn when this is about six inches high, and has been cultivated once. The crop is cut when the corn is beginning to glaze, and when three-fourths of the pea pods are ripe.

The corn and peas are tied into bundles and these run through the silage cutter. The cut corn and peas are carefully leveled off and trampled down in the silo, and about a foot cover of green corn, straw or cottonseed hulls placed on top of the siloed mass. As in case of all legumes, it is safest to wet the cover thoroughly with at least two gallons of water per square foot of surface. This will seal the siloed mass thoroughly and will prevent the air from working in from the surface and spoiling considerable of the silage on top.

A similar effort of combining several feeds for the silo is found in the so-called **Robertson Ensilage Mixture** for the silo, named after Prof. Robertson in Canada. This is made up of cut Indian corn, sunflower seed heads, and horse beans in the proportion of 1 acre corn, $\frac{1}{2}$ acre horse beans, and $\frac{1}{4}$ acre sunflowers. The principle back of the practice is to furnish a feed richer in protein substances than corn, and thus avoid the purchase of large quantities of expensive protein foods like bran, oil meal, etc. Feeding experiments conducted with the **Robertson Silage Mixture** for cows at several experiment stations have

given very satisfactory results, and have shown that this silage mixture can be partly substituted for the grain ration of milch cows without causing loss of flesh or lessening the production of milk or fat. Fifteen pounds of this silage may be considered equivalent to three or four pounds of grain feeds. The practice has not, however, been adopted to any great extent, so far as is known, owing to the difficulty of securing a good quality of silage from the mixture and of growing the horse beans successfully.

Soja beans (soy beans) are another valuable silage crop. According to the U. S. Department of Agriculture the soy bean is highly nutritive, gives a heavy yield, and is easily cultivated. The vigorous late varieties are well adapted for silage. The crop is frequently siloed with corn (2 parts of the latter to 1 of the former), and like other legumes it improves the silage by tending to counteract the acid reaction of corn silage. Of other Southern crops that are used for silage crops may be mentioned Kaffir corn, chicken corn and teosinte.

Sorghum is sometimes siloed in the Western and Middle States, and in the South. It is sown in drills, 3½ inches apart, with a stalk every six to ten inches in the row, and is cut when the kernels are in the dough stage, or before. According to Shelton, the medium-growing saccharine and non-saccharine sorghum are excellent for silage. The sorghums are less liable to be damaged by insects than corn, and they remain green far into the fall, so that the work of filling the silo may be carried on long after the corn is ripe and the stalks all dried up. The yield per acre of green sorghum will often reach 20 tons, or one-half as much again as a good crop of corn. These considerations lead Professor Shelton to pronounce sorghum greatly superior to corn as silage materials, in Kansas, and generally throughout the Central Western States. The Ottawa (Can.) Station states that sorghum, where it can be grown makes an excellent crop for silage. It needs to be cut, the best length, as in the case of corn being three-quarters of an inch long, or less.

Sorghum, like corn, contains an excess of carbohydrates and is somewhat deficient in protein. Its value is increased therefore by the addition of some leguminous crop such as cow peas.

Miscellaneous Silage Crops. In Northern Europe, especially in England, and the Scandinavian countries, meadow grass and after-math (*rowen*) are usually siloed; in England, at the present time, largely in stacks.

In districts near sugar beet factories, where **sugar-beet pulp** can be obtained in large quantities and at a low cost, stock raisers and dairymen have a most valuable aid in preserving the pulp in the silo. As the pulp is taken from the factory it contains about 90 per cent. of water; it packs well in the silo, being heavy, finely divided and homogeneous, and a more shallow silo can therefore be safely used in making pulp silage than is required in siloing corn, and especially clover and other crops of similar character. If pulp is siloed with other fodder crops, it is preferably placed uppermost, for the reason stated. Beet tops and pulp are often siloed in alternate layer in pits 3 to 4 feet deep, and covered with boards and a layer of dirt. Beet pulp can also be successfully placed in any modern deep silo, and is preferably siloed in such silos as there will then be much smaller losses of food materials than in case of shallow silos or trenches in the field.

Wheat, rye and oats have been siloed for summer feeding with some success. A recent correspondent in Hoard's Dairyman tells of sowing some 23 acres of rye and 9 acres of wheat in the fall of 1907 and filling one silo with the rye the following May and the other with wheat early in June, just when they were headed out but before the grain was actually formed. Several acres of oats and peas were put into a third silo the first week in July. In cutting the rye and wheat it was necessary to take the precaution of cutting into short lengths and of carefully treading and packing it in the silo, in order to insure its keeping qualities. "It has kept very well until entirely consumed

by the cattle, and we have no reason to suppose that it would not have kept if we had not used it up when we did. But our experience has been that neither the rye nor the wheat is equal to corn silage for feed. In fact the cows did not eat the rye as clean as they should have done and fell off somewhat in milk. When we began on the wheat, however, they did better and we believe the wheat to be better material for silage than rye."

Beet pulp silage is relatively rich in protein and low in ash and carbohydrates (nutr. ratio 1:5.7; see Glossary). Its feeding value is equal to about half that of corn silage.

Occasional mention has furthermore been made in the agricultural literature of the siloing of a large number of plants, or products, like vetches, small grains (cut green), cabbage leaves, sugar beets, potatoes, potato leaves, turnips, brewers' grains, apple pomace, refuse from corn and pea canning factories; twigs, and leaves, and hop vines; even fern (brake), thistles, and ordinary weeds have been made into silage, and used with more or less success as foods for farm animals.

At a recent convention of the California Dairy Association the president, Mr. A. P. Martin, stated that the best silage he ever made, besides corn, was made of weeds. A piece of wheat which was sowed early, was drowned out, and the field came up with tar weed and sorrel. This was made into silage, and when fed to milch cows, produced most satisfactory results.

Alvord says that a silo may be found a handy and profitable thing to have on a farm even if silage crops are not regularly raised to fill it. There are always waste products, green or half-dry, with coarse materials like swale hay, that are generally used for compost or bedding, which may be made into palatable silage. A mixture, in equal parts, of rag-weed, swamp grass or swale-hay, old corn stalks or straw, and second-crop green clover, nearly three-fourths of which would otherwise be almost useless, will make a superior silage, surprising to those who never tried it.

The following description of the contents filled into a New York silo, which was used as a sort of catch-all, is given by the same writer: 1, 18 in. deep of green oats; 2, 6 in. of red clover; 3, 6 in. of Canada field peas; 4, 3 in. of brewers' grains; 5, 2 feet of whole corn plants, sowed broadcast, and more rag-weed than corn; 6, 5 in. of second-crop grass; 7, 12 in. of sorghum; 8, a lot immature corn cut in short lengths. The silage came out pretty acid, but made good forage, and was all eaten up clean. Damaged crops like frosted beets, potatoes, cabbages, etc.; rutabagas which showed signs of decay, and clover that could not be made into hay because of rain, may all be placed in a silo and thus made to contribute to the food supply on the farm.

A peculiar use of the silo is reported from California, viz., for rendering foxtail in alfalfa fields harmless in feeding cattle. The foxtail which almost takes the first crop of alfalfa in many parts of California, is a nutritious grass, but on account of its beards, is dangerous to feed. By siloing the crop the grass is said to be rendered perfectly harmless; the alfalfa-foxtail silage thus obtained is eaten by stock with great relish and without any injurious effects. (Wall).

CHAPTER VIII.

HOW TO MAKE SILAGE.

Filling the Silo.

A. Indian Corn. As previously stated, corn should be left in the field before cutting until it has passed through the dough stage i. e., when the kernels are well dented or glazed, in case of flint varieties. Where very large silos are filled and in cases of extreme dry weather when the corn is fast drying up, it will be well to begin filling the silo a little before it has reached this stage, as the greater portion of the corn would otherwise be apt to be too dry. There is, however, less danger in this respect now than formerly, on account of our modern deep silos, and because we have found that water applied directly to the fodder in the silo acts in the same way as water in the fodder, and keeps the fermentations in the silo in check and in the right track.

Cutting the Corn in the Field. The cutting of corn for the silo is usually on small farms done by hand by means of a corn knife. Many farmers have been using self-raking and binding corn harvesters for this purpose, while others report good success with a sled or platform cutter. If the corn stands up well, and is not of a very large variety, the end sought may be reached in a satisfactory manner by either of these methods. If, on the other hand, much of the corn is down, hand cutting is to be preferred. A number of different makes of corn harvesters and corn cutters are now on the market; and it is very likely that hand-cutting of fodder corn will be largely done away with in years to come, at least on large farms, indeed, it looks as if the day of the corn knife was passing away, and as if this implement will soon be relegated to obscurity with the sickle of our fathers' time.

If a corn harvester is used, it will be found to be a great advantage to have the bundles made what seems rather small. It will take a little more twine, but the loaders, the haulers, the unloaders, and even the Silage Cutter itself will handle much more corn in a day if the bundles are small and light, and it will be found to be economy to see that this is done.

A platform cutter, which was used with great success, is described by a veteran Wisconsin dairyman, the late Mr. Charles R. Beach.

"We use two wagons, with platforms built upon two timbers, eighteen feet long, suspended beneath the axles. These platforms are about eighteen inches from the ground and are seven feet wide. The cutting knife is fastened upon a small removable platform, two feet by about three and one-half feet, which is attached to the side of the large platform, and is about six or eight inches lower. One row is cut at a time, the knife striking the corn at an angle of about forty-five degrees. One man kneels on the small platform and takes the corn with his arm; two or three men stand upon the wagon, and as soon as he has gotten an armful, the men, each in turn, take it from him and pile it on the wagon. If the rows are long enough a load of one and one-half to two tons can be cut and loaded on in about eight or ten minutes. The small platform is detached from the wagon, the load driven to the silo, the platform attached to the other wagon, and another load is cut and loaded. None of the corn reaches the ground; no bending down to pick up. One team will draw men, cutter, and load, and I do not now well see how the method could be improved. With a steam engine, a large cutter, two teams and wagons, and ten men we filled our silo 22x24x18 feet (190 tons), fast, in less than two days."

Professor Georgeson, has described a one-horse sledge-cutter which has given better satisfaction than any fodder-cutter tried at the Kansas Experiment Station. It is provided with two knives, which are hinged to the body of the sled, and can be folded in on the sled, when not in

use. It has been improved and made easier to pull by providing it with four low and broad cast-iron wheels. It is pulled by a single horse and cuts two rows at a time. Two men stand upon the cutter, each facing a row; as the corn is cut they gather it into armfuls, which they drop into heaps on the ground. A wagon with a low, broad rack follows, on which the corn is loaded and hauled to the silo.

Similar corn cutters have been made by various manufacturers of late years and have proved quite satisfactory, although they require more hand labor than the corn harvesters and do not leave the corn tied up and in as convenient shape for loading on the wagons as these do. It is also necessary to use care with the sledge type of corn cutter, as numerous cases are on record where both men and horses have been injured by getting in front of the knives, which project from the sides.

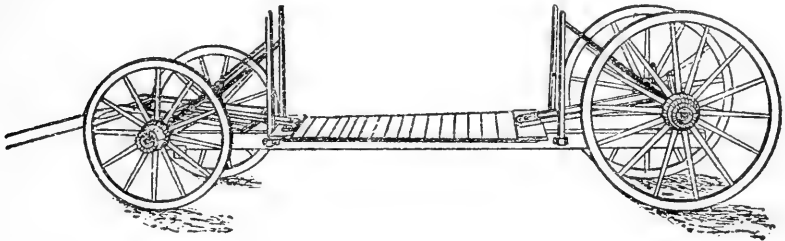

Fig. 27. *Low-down rack for hauling fodder corn.*

A low-down rack for hauling corn from the field is shown in the accompanying illustration (Fig. 27). It has been used for some years past at the Wisconsin Station, and is a great convenience in handling corn, saving both labor and time. These racks not only dispense with a man upon the wagon when loading, but they materially lessen the labor of the man who takes the corn from the ground, for it is only the top of the load which needs to be raised shoulder-high; again, when it comes to unloading, the man can stand on the floor or ground and simply draw the corn toward him and lay it upon the table of the

cutter, without stooping over and without raising the corn up to again throw it down. A plank that can easily be hitched on behind the truck will prove convenient for loading, so that the loader can pick up his armful and, walking up the plank, can drop it without much exertion.

If wilted fodder corn is to be siloed it should be shocked in the field to protect it as much as possible from rain before hauling it to the cutter.

Siloing Corn, "Ears and All."

The best practice in putting corn into the silo, is to silo the corn plant "ears and all," without previously husking it. If the ear corn is not needed for hogs and horses, or for seed purposes, this practice is in the line of economy, as it saves the expense of husking, cribbing, shelling and grinding the ear corn. The possible loss of food materials sustained in siloing the ear corn speaks against the practice, but this is very small, and more than counterbalanced by the advantages gained by this method of procedure. In proof of this statement we will refer to an extended feeding trial with milch cows, conducted by Professor Woll at the Wisconsin Station in 1891.

Corresponding rows of a large corn field were siloed, "ears and all," and without ears, the ears belonging to the latter lot being carefully saved and air-dried. The total yield of silage with ears in it (whole-corn silage) was 59,495 pounds; of silage without ears (stover silage) 34,496 pounds and of ear corn, 10,511 pounds. The dry matter content of the lots obtained by the two methods of treatment was, in whole-corn silage, 19,950 pounds; in stover silage 9,484 pounds, and in ear corn, 9,122 pounds, or 18,606 pounds of dry matter in the stover silage and ear corn combined. This shows a loss of 1,344 pounds of dry matter, or nearly 7 per cent., sustained by handling the fodder and ear corn separately instead of siloing the corn "ears and all."

In feeding the two kinds of silage against each other,

adding the dry ear corn to the stover silage, it was found that seventeen tons of whole-corn silage fed to sixteen cows produced somewhat better results than fourteen tons of stover silage, and more than two tons of dry ear corn, both kinds of silage having been supplemented by the same quantities of hay and grain feed. The yield of milk from the cows was 4 per cent. higher on the whole corn silage ration than on the stover silage ration, and the yield of fat was 6.9 per cent. higher on the same ration. It would seem then that the cheapest and best way of preserving the corn crop for feeding purposes, at least in case of milch cows, is to fill it directly into the silo; the greater portion of the corn may be cut and siloed when the corn is in the roasting-ear stage, and the corn plat which is to furnish ear corn may be left in the field until the corn is fully matured, when it may be husked, and the stalks and leaves may be filled into the silo on top of the corn siloed "ears and all." This will then need some heavy weighting or one or two applications of water on top of the corn, to insure a good quality of silage from the rather dry stalks. (See page 152.)

An experiment similar to the preceding one, conducted at the Vermont Station, in which the product from six acres of land was fed to dairy cows, gave similar results. We are justified in concluding, therefore, that husking, shelling, and grinding the corn (processes that may cost more than a quarter of the market value of the meal) are labor and expense more than wasted, since the cows do better on the corn siloed "ears and all" than on that siloed after the ears were picked off and fed ground with it.

The Filling Process.

The corn, having been hauled from the field to the silo, has still to be reduced to a fine, homogeneous mass, so that it will pack well in the silo and will be convenient for feeding.

In order to do this, the whole of the corn, ears and all, may be run through an "Ohio" Ensilage Cutter.

The corn is unloaded on the table of the cutter and run through the machine, after which the carrier or blower elevates it and delivers it into the silo. The length of cutting practiced differs somewhat with different farmers and with the variety of corn to be siloed. Care should be taken in this respect, however, for the length of cut has much to do with the quality of the silage. Experience has demonstrated that the half inch cut, or even shorter, gives most satisfactory results. The corn will pack and settle better in the silo, the finer it is cut, thus better excluding the air and at the same time increasing the capacity of silo, some say 20 to 25 percent. Cattle will also eat the larger varieties cleaner if cut fine, and the majority of farmers filling silos now practice such cutting.

The cut ensilage should be directed to the outer edge of the silo at all times, thus keeping it high and packing it there, letting the center take care of itself. The weight of the silage packs it in the center.

If the corn is siloed "ears and all," it is necessary to keep a man or boy in the silo while it is being filled, to level the surface and tramp down the sides and corners; if left to itself, the heavier pieces of ears will be thrown farthest away and the light leaves and tops will all come nearest the discharge; as a result the corn will not settle evenly, and the different layers of silage will have a different feeding value. Several simple devices, such as funnel-shaped hoppers, adjustable board suspended from roof, etc., will suggest themselves for receiving the silage from the carrier and directing it where desired in the silo. With the blower machines, the new flexible silo tube shown in the back of this book, is a most happy solution of an otherwise disagreeable job. At the same time it insures perfectly equal distribution of the cut feed; the leaves, moisture and heavier parts being always uniformly mixed as cut.

The Proper Distribution of the Cut Material in the Silo.

The proper distribution of the cut corn after it has been elevated or blown into the silo is a matter which should have proper attention at the time of filling. If the cut material is allowed to drop all in one place and then have no further attention the constant falling of the material in one place will tend to make that portion solid while the outside will not be so, and besides the pieces of ears and heavier portions will continually roll to the outside. As a result the silage cannot settle evenly, and good results will not follow. As the filling progresses, the cut material should be leveled off and the common and most successful practice is to keep the material higher at the sides than at the center and do all the tramping at and close to the sides, where the friction of the walls tends to prevent as rapid settling as takes place at the center. For this reason, no tramping, or at least, as little as possible, should be done, except close to the walls. In modern deep silos, the weight of the silage accomplishes more than would any amount of tramping, and all that is necessary, is to see that the cut material is rather evenly distributed, for better results in feeding, and to assist the settling by some tramping at the sides. With the new silo tube, this distribution is really reduced to the mere guiding of the mouth of the tube by hand.

Size of Cutter and Power Required.

The "Ohio" Cutters are made in a variety of sizes, suited to all requirements.

The cutter used in filling the silo should have ample capacity to give satisfaction and do the work rapidly; a rather large cutter is therefore better than a cutter that is barely large enough. The size required depends on the rapidity with which it is desired to fill the silo and on the power at hand. Where a steam engine is available it is the cheapest power for filling a large silo, as the

work can then be finished in a few days. For small farms and silos, where an engine is not to be had, a two or three-horse tread-power may be used, but it will be found that the work of filling will progress much more slowly than when steam power, such as is suitable for threshing, is used. The filling may be done as rapidly as possible, or may be done slowly, and no harm will result if, for any reason the work be interrupted for some time. More silage can be put into a silo with slow, than with rapid filling. If the farmer owns his own machine, he can, of course, fill his silo and then refill after the silage has settled, so that the silo will be nearly full after all settling has taken place.

If, however, the farmer must depend on hiring an outfit, he will wish to do the filling as rapidly as possible, as a matter of economy. It is, therefore, desirable for the farmer to own his own machine, and that being the case, a smaller machine will suffice; whereas if the machine be hired the largest possible capacity will be desired.

This has created a demand for various sizes of cutters, and to meet this demand, the "Ohio" Ensilage Cutters are made in six sizes, with knives eleven to twenty-two inches long, and with Metal Bucket Elevators, or Blower Elevators, as desired, adaptable to any height of silo. The traveling feed table (supplied on all but the smallest size "Ohio" Ensilage Cutter, No. 11) and the bull-dog grip feed rolls are valuable features and practically do away with the labor of feeding the heavy green corn, besides increasing the capacity of the machines about one-third, on account of its being so much easier to get a large amount of material past the feed rolls.

The Metal Bucket Elevator is the older style of elevator. It delivers the cut silage corn into the silo through a window or opening at the top and must be longer than the silo is high as it is necessary to run the carrier at somewhat of an angle. The length of the carrier required may be obtained by adding about 40 per cent. to the per-

pendicular height from the ground to the window; thus for a 20 ft. silo a 28 ft. carrier is required, and for a 30 ft. silo, about 42 ft. of carrier will be necessary.

The metal Bucket Elevators for the "Ohio" Cutters are made both straight away and with swivel base, which enables the operator to set the cutter in the desired position, and as the swivel base gives the carrier a range of adjustment extending over nearly a half circle, the carrier can be run directly to the window, or in the case of two silos setting side by side, both can be filled with one setting of the cutter.

The No. 12 "Ohio" Monarch Cutter, with carrier (the number of the machine indicates the length of knives and width of throat), has a capacity of 8 to 12 tons of green corn per hour, and requires 4 to 6 horse-power to run it to full capacity, although it can be operated successfully with less power, by feeding in proportion to the power at hand. The Blower machines require more power to operate successfully than do the Carrier machines. The 14, 17, 19 and 22 inch "Ohio" Cutters have correspondingly larger capacities, and in the case of the larger sizes the amount that can be cut is only limited by the amount that can be conveniently gotten to them. The largest sizes can be run by an ordinary threshing engine. These machines have been on the market for upwards of twenty-five years, and have been brought to a wonderful state of perfection. For durability, ease and reliability of operation, capacity and general utility, they are doubtless the most practical means of filling the silo.

The Nos. 14, 17 and 19 "Ohio" Cutters are the sizes mostly in use by farmers and dairymen, and the traveling feed table, which is long enough to receive a bundle of corn, is a most valuable feature, and has become almost universal on the "Ohio" machines used for silo filling. It decreases the labor of feeding and makes any size of machine about equal in capacity to the next size larger without it.

The newer and more modern method of elevating fod-

der in filling silos, is the use of the Blower Elevator which blows the cut fodder into the silo through a continuous pipe. Blower Elevators (see illustration of "Ohio" Blower Cutter, Fig. 29) have been in use to an increasing extent for several years, and today there is absolutely no doubt as to their superiority for elevating the material. Where sufficient power is available there is no difficulty in elevating the cut fodder into the highest silos.

Although the Blower Machines require somewhat more power than the old style Carrier, they have numerous

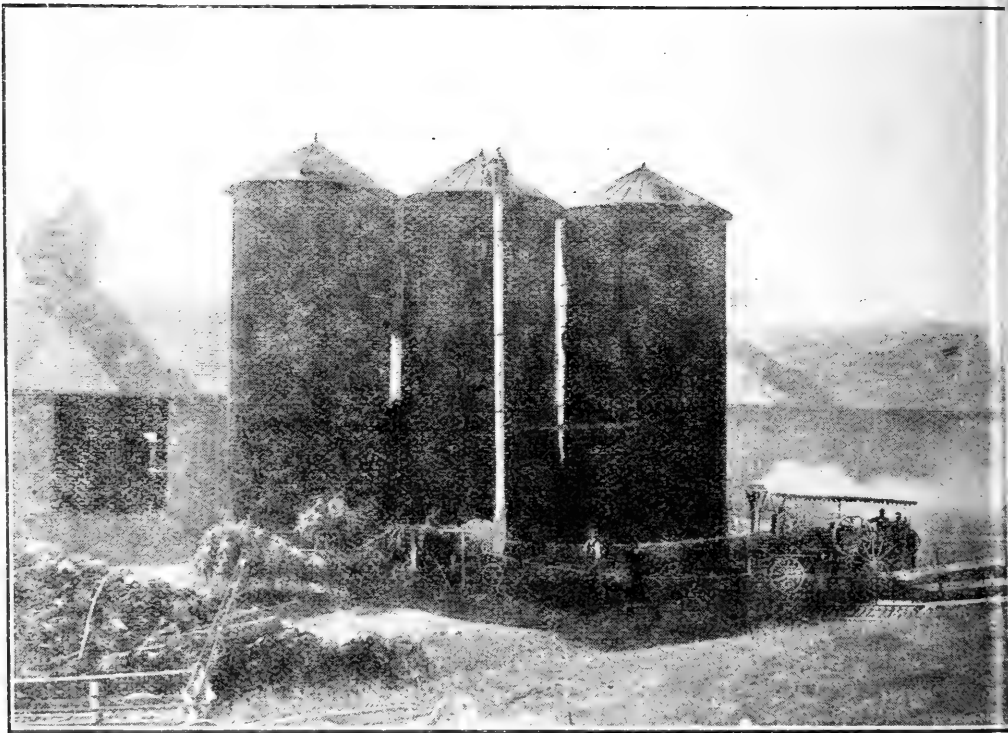

Fig. 29. *This illustration shows a No. 19 Monarch Self-Feed Blower Cutter filling three forty-foot silos, 500 tons capacity, at the Ingleside Farms, Thorndale, Chester county, Pa. At the time the photograph was taken, this machine had just replaced an exploded fly-wheel cutter which nearly killed one of the workmen.*

advantages over the latter, and the majority of machines now being sold are equipped with Blowers. We mention below some of the features that have served to bring the "Ohio" Monarch Blowers to the notice and favor of farmers and dairymen so rapidly.

The Blower Machine is quickly set up, taken down or moved, as all that is necessary is to remove the pipe, (which is in sections of various lengths from four to ten feet as desired), which requires but a few moments. This operation requires but little time as compared with that occupied in setting up or taking apart the chain elevator.

The Blower Machine is clean in operation, placing all of the corn in the silo and there is no litter around the machine when the filling is finished.

The action of the fan paddles is such that the corn is made much finer, and it therefore packs closer in the silo, thus enabling more fodder to be stored in the silo; the corn is all knocked off of the pieces of cobs and distributed through the cut fodder better, and the pieces of the heavy butts and joints are also split and knocked to pieces, all of which reduces the silage to a fine condition so that it is eaten up cleaner by the stock.

The fan or blower device is also likely to be more durable than the chain elevator.

Many have been skeptical as to the ability of the Blower to elevate the material as rapidly as the "Ohio" Machines cut it. This proposition, however, has been proven entirely feasible and successful, and there positively need be no fear on this point if the following points are kept in mind.

The machine must be run at the proper speed as recommended by the manufacturers. A fan can only create a sufficient blast by running fast enough to force the air through the pipe at the rate of nine or ten thousand feet per minute. Green corn is heavy stuff and requires a strong current of air to carry it through 30 or 40 feet of pipe at the rate of 10 to 30 tons per hour. It

will be seen, therefore, that unless proper speed be maintained there will be no elevation of the material whatever. If the power at hand is not sufficient to maintain full speed when the cutters are fed to full capacity, all that is necessary is to feed the machine accordingly, in other words, to cut down the capacity to the point where full speed can be maintained, as is necessary with other kinds of machinery, such as threshing machines, grinding mills, etc.

In setting a Blower Machine it is necessary to have the pipe as nearly perpendicular as possible, so that the current of air within the pipe will lift the material. This is especially true where the pipe is long, say 20 feet or more, because the green fodder being heavy will settle down onto the lower side of the pipe, if this has much slant, and the wind blast will pass over the fodder, thus allowing it to lodge, whereas if the pipe be perpendicular, or nearly so, no stoppage will occur. It is also necessary to see that full speed is attained before beginning to feed the machine, and also to stop the feeding while the machine is in full motion so that the Blower will have an opportunity to clear itself before shutting off the power.

There must be ample vent in the silo to prevent back pressure, as the tremendous volume of air forced into the silo with the cut fodder must have some means of escape.

If these few points are kept in mind, there can be no possible doubt as to the successful operation of the Blower Elevator; and, as previously stated, there is absolutely no doubt as to their superiority for elevating silage. Scores of "Ohio" Blower Machines are in successful use in all parts of the country.

(N. B. At the end of this volume will be found illustrations and descriptions of several sizes and styles of "Ohio" Cutters, which the reader can refer to, in addition to the illustrations given here.)

Danger from Carbonic-Acid Poisoning in Silos.—As soon as the corn in the silo begins to heat, carbonic-acid

gas is evolved, and if the silo is shut up tight the gas will gradually accumulate directly above the fodder, since it is heavier than air and does not mix with it under the conditions given. If a man or an animal goes down into this atmosphere, there is great danger of asphyxiation, as is the case under similar conditions in a deep cistern or well. Poisoning cases from this cause have occurred in filling silos where the filling has been interrupted for one or more days, and men have then gone into the silo to tramp down the cut corn. If the doors above the siloed mass are left open when the filling is stopped, and the silo thus ventilated, carbonic acid poisoning cannot take place, since the gas will then slowly diffuse into the air. Carbonic acid being without odor or color, to all appearances like ordinary air, it cannot be directly observed, but may be readily detected by means of a lighted lantern or candle. If the light goes out when lowered into the silo there is an accumulation of carbonic acid in it, and a person should open feed doors and fan the air in the silo before going down into it.

After the silage is made and the temperature in the silo has gone down considerably, there is no further evolution of carbonic acid, and therefore no danger in entering the silo even if this has been shut up tight. The maximum evolution of carbonic acid, and consequently the danger of carbonic-acid poisoning comes during or directly after the filling of the silo.

Covering the Siloed Fodder.

Many devices for covering the siloed fodder have been recommended and tried, with varying success. The original method was to put boards on top of the fodder, and to weight them heavily by means of a foot layer of dirt or sand, or with stone. The weighting having later on been done away with, lighter material, as straw, hay, sawdust, etc., was substituted for the stone or sand. Building paper was often placed over the fodder, and boards on top of the paper. There is no special advan-

tage derived from the use of building-paper, and it is now never used. Many farmers run some corn stalks, or green husked fodder, through the cutter after the fodder is all in. In the South, cotton-seed hulls are easily obtained, and form a cheap and most efficient cover.

None of these materials or any other recommended for the purpose can perfectly preserve the uppermost layer of silage, some four to six inches of the top layer being usually spoilt. Occasionally this spoilt silage may not be so bad but that cattle or hogs will eat it up nearly clean, but it is at best very poor food, and should not be used by any farmer who cares for the quality of his products. The wet or green materials are better for cover than dry substances, since they prevent evaporation of water from the top layer; when this is dry air will be admitted to the fodder below, thus making it possible for putrefactive bacteria and molds to continue the destructive work begun by the fermentation bacteria, and causing more of the silage to spoil.

Use of Water in Filling Silos.—During late years the practice of applying water to the fodder in the silo has been followed in a large number of cases. The surface is tramped thoroughly and a considerable amount of water added. In applying the method at the Wisconsin Station, Prof. King, a few days after the completion of the filling of the silo, added water to the fodder corn at the rate of about ten pounds per square foot of surface, repeating the same process about ten days afterwards. By this method a sticky, almost impervious layer of rotten silage, a couple of inches thick, will form on the top, which will prevent evaporation of water from the corn below, and will preserve all but a few inches at the top. The method can be recommended in cases where the corn or clover goes into the silo in a rather dry condition, on account of drouth or extreme hot weather, so as not to pack sufficiently by its own weight. While weighting of the siloed fodder has long since been done away with, it may still prove advantageous to resort to it where very dry fodder is siloed,

or in case of shallow silos. Under ordinary conditions neither weighting nor application of water should be necessary.

There is only one way in which all of the silage can be preserved intact, viz., by beginning to feed the silage within a few days after the silo has been filled. This method is now practiced by many farmers, especially dairymen, who in this manner supplement scant fall pastures.

By beginning to feed at once from the silo, the siloing system is brought to perfection, provided the silo structure is air-tight, and constructed so as to admit of no unnecessary losses of nutrients. Under these conditions there is a very considerable saving of food materials over silage made in poorly constructed silos, or over field-cured shocked fodder corn, as we have already seen.

Clover Silage.

Green clover may be siloed whole or cut, but the latter method is to be recommended. The clover should not be left to wilt between cutting and siloing, and the silo should be filled rapidly, so as to cause no unnecessary losses by fermentation.

The different species of clover will prove satisfactory silo crops; ordinary red or medium clover is most used in Northwestern States, along with mammoth clover; the latter matures later than medium or red clover, and may therefore be siloed later than these. Alfalfa, or lucerne, is, as previously stated, often siloed in the West. Under the conditions present there it will generally produce much larger yields than corn, and, preserved in a silo, will furnish a large supply of most valuable feed. Prof. Neale and others recommended the use of scarlet clover for summer silage, for Delaware and States under similar climatic conditions.

Says a Canadian dairy farmer: "If we were asked for our opinion as to what will most help the average

dairy farmer, I think we would reply: Knowledge of a balanced ration, the Babcock test, and a summer silo; then varying the feed of individual animals according to capacity; as shown by scales and close observation."

Clover for Summer Silage.

By filling the clover into the silo at midsummer, or before, space is utilized that would otherwise be empty; the silage will, furthermore, be available for feeding in the latter part of the summer and during the fall, when the pastures are apt to run short. This makes it possible to keep a larger number of stock on the farm than can be the case if pastures alone are to be relied upon, and thus greatly facilitates intensive farming. Now that stave silos of any size may be easily and cheaply put up, it will be found very convenient at least on dairy farms, to keep a small separate silo for making clover silage that may be fed out during the summer, or at any time simultaneously with the feeding of corn silage. This extra silo may also be used for the siloing of odd lots of forage that may happen to be available (see page 60). It is a good plan in siloing clover or other comparatively light crops in rather small silos, to put a layer of corn on top that will weight down the mass below, and secure a more thorough packing and thereby also a better quality of silage.

In several instances where there has still been a supply of clover silage in the silo, green corn has been filled in on top of the clover, and the latter has been sealed and thus preserved for a number of years. Corn silage once settled and "sealed," will also keep perhaps indefinitely when left undisturbed in the silo, without deteriorating appreciably in feeding value or palatability.

Prof. Cottrell writing for Kansas farmers, says: "Silage will keep as long as the silo is not opened, and has been kept in good condition for seven years. This is a special advantage for Kansas dairymen, as in years of heavy crops the surplus can be stored in silos for

years of drouth, making all years good crop years for silo dairymen."

Freezing of Silage

Freezing of silage has sometimes been a source of annoyance and loss to farmers in Northern States, and in the future, with the progress of the stave silo, we shall most likely hear more about frozen silage than we have in the past. As stated in the discussion of the stave silo, however, the freezing of silage must be considered an inconvenience rather than a positive detriment; when the silage is thawed out it is eaten with the same relish by stock as is silage that has never been frozen, and apparently with equally good results. If frozen silage is not fed out directly after thawed it will spoil and soon become unfit to be used for cattle food; thawed silage will spoil much sooner than ordinary silage that has not been frozen and thawed out. There is no evidence that silage which has been frozen and slowly thawed out, is less palatable or nutritious than silage of the same kind which has been kept free from frost.

"Freezing of silage," says Iowa State College Bulletin No. 100, "is due to loss of heat; first, through the silo wall; and second, to the air in contact with the feeding surface.

"It may be impartially said that, as far as the prevention of freezing is concerned, the stave, stone, single wall brick and concrete silos are of about equal merit.

"The second cause of freezing mentioned, that is, the loss of heat from the silage surface, is too often the cause of unnecessary freezing. If air above the silage is confined, no serious loss of heat can possibly take place. When the top of the silo is open and a free circulation of air permitted, it is almost impossible to prevent the surface from freezing in severe weather. A personal investigation of silos in cold weather proved conclusively that those provided with a tight roof did not contain nearly as much frozen silage as those left open."

The difficulty of the freezing of the silage may be avoided by checking the ventilation in the silo and by leaving the door to the silo carefully closed in severe weather. If the top layer of silage freezes some of the warm silage may be mixed with the frozen silage an hour or two before feeding time, and all the silage will then be found in good condition when fed out. A layer of straw may be kept as a cover over the silage; this will prevent it from freezing, and is easily cleared off when silage is to be taken out.

Silage From Frosted Corn.

Experiments were conducted at the Vermont Station in October, 1906, with immature corn, mature corn not frosted, and mature corn frosted hard or frozen and the leaves whitened. No ill results were noticeable in the butter product. It was found that "the effect of frosting corn, and still more of freezing it, appears very slightly to have been to depress its feeding value when made into silage." The testimony seemed in favor of running frost risks in order to gain a greater maturity, rather than to silo the immature product.

Steamed Silage.

While fermentation in silage causes a small unavoidable loss, it develops flavors and softens the plant tissue. Excessive fermentation causes high acid. Steam has been used with much success to check it in such cases, says Farmer's Bulletin No. 316. It is piped at the bottom and middle of the silo until the whole mass is hot.

Steaming seems beneficial and silage so treated is considered much better than that which is not steamed. Stall fed animals have eaten from 50 to 75 lbs. of silage per day.

CHAPTER IX.

HOW TO FEED SILAGE.

Silage is eaten with a relish by all kinds of farm animals, dairy and beef cattle, horses, mules, sheep, goats, swine, and even poultry. It should never be fed as sole roughage to any one of these classes of stock, however, but always in connection with some dry roughage. The nearer maturity the corn is when cut for the silo the more silage may safely be fed at a time, but it is always well to avoid feeding it excessively.

The silo should always be emptied from the top in horizontal layers, and the surface kept level, so as to expose as little of the silage as possible to the air. It should be fed out sufficiently rapidly to avoid spoiling of the silage; in ordinary Northern winter weather a layer a couple of inches deep should be fed off daily.

Silage for Milch Cows.

Silage is **par excellence** a cow feed, says Prof. Woll in his Book on Silage. Since the introduction of the silo in this country, the dairymen, more than any other class of farmers, have been among the most enthusiastic siloists, and up to the present time a larger number of silos are found in dairy districts than in any other regions where animal husbandry is a prominent industry. As with other farm animals, cows fed silage should receive other roughage in the shape of corn stalks, hay, etc. The quantities of silage fed should not exceed forty, or at outside, fifty pounds per day per head. It is possible that a maximum allowance of only 25 or 30 pounds per head daily is to be preferred where the keeping quality of the milk is an important consideration, especially if the silage was made from somewhat

immature corn. The silage may be given in one or two feeds daily, and, in case of cows in milk, **always after milking**, and not before or during same, as the peculiar silage odor may, in the latter case, in our experience reappear in the milk. (See below.)

Silage exerts a very beneficial influence on the secretion of milk. Where winter dairying is practiced, cows will usually drop considerably in milk toward spring, if fed on dry feed, causing a loss of milk through the whole remaining portion of the lactation period. If silage is fed there will be no such marked decrease in the flow of milk before turning out to grass, and the cows will be able to keep up well in milk until late in summer,

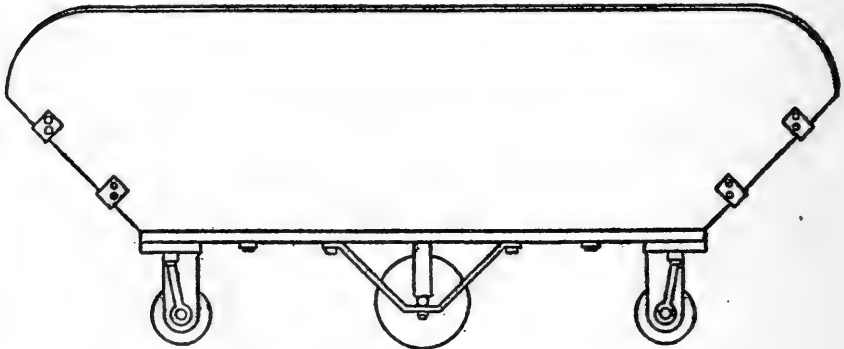

Fig. 30. *Silage Truck.*

or early in the fall, when they are dried up prior to calving. Silage has a similar effect on the milk secretion as green fodder or pasture, and if made from well-matured corn, is more like these feeds than any other feed the farmer can produce.

The feeding of silage to milch cows has sometimes been objected to when the milk was intended for the manufacture of certain kinds of cheese, or of condensed milk, and there are instances where such factories have enjoined their patrons from feeding silage to their cows. When the latter is properly prepared and properly fed,

there can be no foundation whatever for this injunction; it has been repeatedly demonstrated that Swiss cheese of superior quality can be made from the milk of silage-fed cows, and condensing factories among whose patrons silage is fed have been able to manufacture a superior product. The quality of the silage made during the first dozen years of silo experience in this country was very poor, being sour and often spoilt in large quantities, and, what may have been still more important, it was sometimes fed in an injudicious manne.

being made to subsist on this feed as sole roughage. Under these conditions it is only natural that the quality of the milk should be impaired, and that manufacturers preferred to entirely prohibit the use of it rather than to teach their patrons to follow proper methods in the making and feeding of silage. There is an abundance of evidence at hand showing that good silage fed in moderate quantities will produce an excellent quality of both butter and cheese. According to the testimony of butter experts, silage not only does not injure the flavor of butter, but better-flavored butter is produced by judicious silage feeding than can be made from dry feed.

Silage in the production of "certified milk."—In answer to a question raised whether there is any objection made to the milk when the cows are fed silage, Mr. H. B. Gurler, the well-known Illinois dairyman, whose certified milk sent to the Paris Exposition in 1900, kept sweet for one month without having any preservatives added to it, and was awarded a gold medal, gave the following information: "No, there is not. I have had persons who knew I was feeding silage imagine they could taste it. I caught one of the leading Chicago doctors a while ago. He imagined that he could taste silage in the milk, and I was not feeding it at all. When I first went into the business I did not feed any silage to the cows from which the certified milk was produced. I knew it was all right for butter making, as I had made butter from the milk of cows fed with silage, and sent it to New

York in competition with butter made from dry food, and it proved to be the finer butter of the two. The first winter I had samples sent down to my family in De Kalb from the stable where we fed silage and from the stable where we were making the certified milk for Chicago, and in which we fed no silage. I presume I made one hundred comparative tests that winter of the milk from these two stables. My wife and daughter could not tell the difference between the two samples. In the large majority of cases they would select the milk from the cows fed silage as the sweeter milk."

It will serve as an illustration of the general use of silage among progressive dairymen in our country, to state that of one hundred farmers furnishing the feed rations fed to their dairy cows, in an investigation of this subject conducted by Prof. Woll in 1894, sixty-four were feeding silage to their stock, this feed being used a larger number of times than any other single cattle food, wheat bran only excepted.

An interesting experiment as to the effect of silage on milk was recently conducted by the Illinois Station, where a herd of 40 cows was divided, one lot being fed 40 lbs. of silage a day, the other clover hay and grain. Samples of milk were submitted to 372 persons for an opinion. Sixty per cent. preferred the silage-fed milk, 29 per cent. non-silage-fed milk, while 11 per cent. had no choice. They were able to distinguish between the two kinds, but found nothing objectionable about either. The summary of the test was that when silage imparts a bad or disagreeable flavor to milk produced from it, almost invariably the cause is that the silage has not been fed properly, or that spoiled silage has been used.

It has been contended that the acetic acid in ensilage has a tendency to make milk sour more quickly. A user of ensilage for 14 years, took a gallon of milk from a cow fed ensilage for 42 days and a gallon from another that had received no ensilage and set them side by side in a room having a temperature of 40 degrees. Both gallons of milk began to sour at the same time.

The combination in which corn silage will be used in feeding milch cows will depend a good deal on local conditions; it may be said in general that it should be supplemented by a fair proportion of nitrogenous feeds like clover hay, wheat bran, ground oats, linseed meal, gluten feed, cotton-seed meal, etc. As it may be of some help to our readers a number of balanced rations or such as are near enough balanced to produce good results at the pail, are presented below.

Silage Rations for Milch Cows.

- No. 1. Corn silage, 35 lbs.; hay, 8 lbs.; wheat bran, 4 lbs.; ground oats, 3 lbs.; oil meal, 2 lbs.
- No. 2. Corn silage, 50 lbs.; corn stalks, 10 lbs.; corn meal, 2 lbs.; wheat bran, 4 lbs.; malt sprouts, 3 lbs.; oil meal, 1 lb.
- No. 3. Corn silage, 40 lbs.; clover and timothy mixed, 10 lbs.; wheat shorts, 3 lbs.; gluten feed, 3 lbs.; corn and cob meal, 3 lbs.
- No. 4. Corn silage, 20 lbs.; corn stalks, 10 lbs.; hay, 4 lbs.; wheat bran, 4 lbs.; gluten meal, 3 lbs.; ground oats, 3 lbs.
- No. 5. Corn silage, 40 lbs.; clover hay, 10 lbs.; oat feed, 4 lbs.; corn meal, 3 lbs.; gluten feed, 3 lbs.
- No. 6. Corn silage, 45 lbs.; corn stalks, 5 lbs.; oat straw, 5 lbs.; dried brewers' grains, 4 lbs.; wheat shorts, 4 lbs.
- No. 7. Corn silage, 35 lbs.; hay, 10 lbs.; corn meal, 3 lbs.; wheat bran, 4 lbs.; oats, 3 lbs.
- No. 8. Corn silage, 40 lbs.; corn stover, 8 lbs.; wheat bran, 4 lbs.; gluten meal, 2 lbs.; oil meal, 2 lbs.
- No. 9. Corn silage, 20 lbs.; clover and timothy hay, 15 lbs.; corn meal, 3 lbs.; ground oats, 3 lbs.; oil meal, 2 lbs.; cotton seed meal, 1 lb.
- No. 10. Clover silage, 25 lbs.; corn stover, 10 lbs.; hay, 5 lbs.; wheat shorts, 2 lbs.; oat feed, 4 lbs.; corn meal, 2 lbs.

No. 11. Clover silage, 30 lbs.; dry fodder corn, 10 lbs.; oat straw, 4 lbs.; wheat bran, 4 lbs.; malt sprouts, 2 lbs.; oil meal, 2 lbs.

No. 12. Clover silage, 40 lbs.; hay, 10 lbs.; roots, 20 lbs.; corn meal, 4 lbs.; ground oats, 4 lbs.

The preceding rations are only intended as approximate guides in feeding dairy cows. Every dairy farmer knows that there are hardly two cows that will act in exactly the same manner and will need exactly the same amount of feed. It is then important to adapt the quantities and kinds of feed given to the special needs of the different cows; one cow will fatten on corn meal, where another will be able to eat and make good use of two or three quarts of it. In the same way some cows will eat more roughage than others and do equally well on it as those that get more of the food in the form of more concentrated and highly digestible feeding stuffs. The only safe rule to go by is to feed according to the different needs of the cows; to study each cow and find out how much food she can take care of without laying on flesh, and how she responds to the feeding of foods of different character, like wheat bran and corn meal, for instance. The specimen rations given in the preceding can, therefore, only be used to show the average amount of common feeds which a good dairy cow can take in and give proper returns for.

The popularity of the silo with owners of dairy cattle has increased very greatly, says Prof. Plumb. Few owners of stock of this class, who have properly-built silos, and well-preserved silage, would discard silage as an adjunct to feeding. Silage certainly promotes milk flow. One great argument in favor of its use lies in the cheapness of production per ton, and the ability to store and secure a palatable, nutritious food in weather conditions that would seriously injure hay or dry fodder.

There is one important point that owners of milk cattle should bear in mind, and that is when the silo is first opened only a small feed should be given. In chang-

ing from grass or dry feed to silage, if a regular full ration is given, the silage will perhaps slightly affect the taste of the milk for a few milkings, and if the change is from dry feed it may cause too great activity of the bowels.

Silage for Beef Cattle.

Silage may be fed with advantage to beef cattle, in moderate quantities, up to about forty pounds a day. The health of the animals and the quality of the beef produced on moderate silage feeding, leave nothing to be wished for. If the silage is made from immature corn care must be taken not to feed too large quantities at the start, and to feed carefully, so as not to make the animals scour. Prof. Henry says in regard to the value of silage for fattening steers: "As with roots, silage makes the carcass watery and soft to the touch. Some have considered this a disadvantage, but is it not a desirable condition in the fattening steer? Corn and roughage produce a hard dry carcass, and corn burns out the digestive tract in the shortest possible time. With silage and roots, digestion certainly must be more nearly normal, and its profitable action longer continued. The tissues of the body are juicy, and the whole system must be in just that condition which permits rapid fattening. While believing in a large use of silage in the preliminary stages, and its continuance during most of the fattening period, I would recommend that gradually more dry feed be substituted as the period advances, in order that the flesh may become more solid. Used in this way, I believe silage will become an important aid in steer feeding in many sections of the country. Results from Canada, Wisconsin, and Texas experiment stations show the broad adoption of this food for stock feeding purposes.

Young stock may be fed half as much silage as full grown ones, with the same restrictions and precautions as given for steers. Experience obtained at the Kansas Station suggests that corn silage is not a fit food for

breeding bulls, unless fed a few pounds only as a relish; fed heavily on silage, bulls are said to lose virility and become slow and uncertain breeders.

Fuller information on this subject is given in Chapter III of this book, entitled, "The Use of Silage in Beef Production."

Silage for Horses.

When fed in small quantities, not to exceed fifteen pounds a day, silage is a good food for horses. It should be fed twice a day, a light feed being given at first and gradually increased as the animals become accustomed to the food. Some farmers feed it mixed with cut straw, two-thirds of straw and one-third of silage, and feed all the horses will eat of this mixed feed. Some horses object to silage at first on account of its peculiar odor, but by sprinkling some oats or bran on top of the silage and feeding only very small amounts to begin with, they soon learn to eat and relish it. Other horses take it willingly from the beginning. Horses not working may be fed larger quantities than work horses, but in neither case should the silage form more than a portion of the coarse feed fed to the horses. Silage-fed horses will look well and come out in the spring in better condition than when fed almost any other food.

Professor Cook says in regard to silage as a horse food: "It has been suggested by even men of high scientific attainments that silage is pre-eminently the food for cattle and not for other farm stock. This is certainly a mistake. If we raise fall colts, which I find very profitable, then silage is just what we need, and will enable us to produce colts as excellent as though dropped in the spring. This gives us our brood mares in first-class trim for the hard summer's work. I find silage just as good for young colts and other horses."

An extensive Michigan farmer and horse breeder gives his experience in regard to silage for horses as

follows: "Last year we had nearly two hundred horses, including Clydesdales, standard-bred trotters, and Shetland ponies. They were wintered entirely upon straw and corn silage, and this in face of the fact that I had read a long article in a prominent horse journal cautioning farmers from the use of silage, and citing instances where many animals had died, and brood mares had aborted from the liberal use of corn silage.

"Desiring to test the matter to the fullest extent, our stallions and brood mares, as well as all the young stock, we fed two full rations of silage daily, and one liberal ration of wheat or oat straw. The result with our brood mares was most phenomenal, for we now have to represent every mare that was in foal on the farm, a weanling, strong and vigorous, and apparently right in every way, with only one exception, where the colt was lost by accident. Of course there may have been something in the season more favorable than usual, but this was the first year in my experience when every colt dropped on the farm was saved."

The following experience as to the value of silage as a food for horses and other farm animals comes from the Ohio Station: "Our silo was planned and filled with special reference to our dairy stock, but after opening the silo we decided to try feeding the silage to our horses, calves and hogs. The result was eminently satisfactory. We did not find a cow, calf, horse, colt, or hog that refused to eat, or that did not eat it with apparent relish, not only for a few days, but for full two months. The horses were given one feed of twenty pounds each per day in place of the usual amount of hay, for the period above named, and it was certainly a benefit. Their appetites were sharpened, and the healthfulness of the food was further manifest in the new coat of hair which came with the usual spring shedding. The coat was glossy, the skin loose, and the general appearance was that of horses running upon pasture."

Doctor Bailey states that silage has as good an effect

on work and driving horses as an occasional feed of carrots or other roots, and Rew informs us that there is a demand for silage in London and other English cities, especially for omnibus, cab, and tram horses. According to the testimony of Mr. H. J. Elwes, the cart horses fed silage "looked in better condition and brighter in their coats than usual at this time of the year."

From experiments conducted at Virginia Station, Prof. Nourse concluded that "it would appear that silage would make a good roughage for horses, when used in connection with hay or stover or grain, but that these animals should become accustomed to the food by degrees, and that this is as important as when changing from old to new corn, or from hay to grass."

What has been said about silage as a food for horses will most likely apply equally well to mules, although only very limited experience has so far been gained with silage for this class of farm animals.

Silage for Sheep.

Silage is looked upon with great favor among sheep men, says Prof. Woll in his Book on Silage; sheep do well on it, and silage-fed ewes drop their lambs in the spring without trouble, the lambs being strong and vigorous. Silage containing a good deal of corn is not well adapted for breeding stock, as it is too fattening; for fattening stock, on the other hand, much corn in the silage is an advantage. Sheep may be fed a couple of pounds of silage a day and not to exceed five or six pounds per head. Prof. Cook reports as follows in regard to the value of silage for sheep: "I have fed ensilage liberally to sheep for three winters and am remarkably pleased with the results. I make ensilage half the daily ration, the other half being corn stalks or timothy hay, with bran or oats. The sheep do exceedingly well. Formerly I was much troubled to raise lambs from grade Merino ewes. Of late this trouble has almost ceased. Last spring I hardly lost a lamb. While ensilage may not be

the entire cause of the change, I believe it is the main cause. It is positively proved that ensilage is a most valuable food material, when properly fed, for all our domestic animals."

Mr. J. S. Woodward, a well-known New York farmer and Farmers' Institute Worker, who has made a specialty of early-lamb raising, says in an address before the New York Agricultural Society, regarding silage as a feed for lambs: "In order to be successful in raising fine lambs it is imperative that the ewes and lambs both should have plenty of succulent food. Nothing can supply the deficiency. For this purpose roots of almost any kind are good. Turnips, rutabagas, mangolds are all good. Corn silage is excellent. Could I have my choice I would prefer both silage and roots. If I were depending on silage alone for succulent food I would give four pounds per hundred pounds live weight of sheep, all at one feed, at the forenoon feed; but when feeding both silage and roots I would feed silage in the morning and roots in the afternoon."

Mr. J. M. Turner of Michigan says concerning silage for sheep: "Of late years we have annually put up 3,200 tons of corn ensilage, and this has been the principal ration of all the live stock at Springdale Farm, our Shropshire sheep having been maintained on a ration of ensilage night and morning, coupled with a small ration of clover hay in the middle of the day. This we found to fully meet the requirements of our flock until after lambing, from which time forward we of course added liberal rations of wheat bran, oats, and old-process linseed meal to the ewes, with a view of increasing their flow of milk and bringing forward the lambs in the most vigorous possible conditions. Our flock-master was somewhat anxious until after the lambs dropped, but now that he saved 196 lambs from 122 ewes, his face is wreathed in smiles, and he gives the ensilage system the strongest endorsement." Mr. Turner states that, after becoming accustomed to the silage, his horses, cattle, and

sheep would all push their noses down through the hay, if there was silage at the bottom of the manger, and little or no hay would be eaten until the silage was first taken.

O. C. Gregg, superintendent of farmers' institutes for Minnesota, has been conducting some experiments on feeding ensilage to sheep. He gives the result in one of our American exchanges as follows:

"We made preparations to use ensilage in the feeding of our flock during the past winter. We have now some facts to report which seem to verify the thought that we had—that ensilage will enter as a large factor in the future production of good mutton in Minnesota. Our ensilage has been fed (beginning gradually) in troughs. These troughs can be readily cleaned by being turned over, that the center piece prevents any chance of the sheep jumping over them and so soiling the food. The troughs are also wide enough so that two rows of sheep will feed from them without undue crowding. We have enough of these troughs, so that when the flock is feeding, each sheep has a reasonable space to feed quietly. This in itself is an advantage that every feeder of stock will understand.

"As a result so far, the sheep are in better condition than we have ever had them before, and, in fact, to use an English term, they are in "blooming" condition. We do not consider that they are any too fleshy, but in a good, bright, healthy state. The wool is evidently of good quality, and the flock will shear heavily. The sheep are high grade Shropshires. Good shepherds have estimated that they will furnish between seven and eight pounds of wool per head. There are a few young ewes in the flock which we do not consider in this estimate. The ewes are beautiful to look at, square on the back, bright of eye, active in appearance, and when the time comes for the feeding of ensilage they are anxious for their feed, and in case there is any lapse in time, they soon make their wants known by bleating about the

troughs. The flock has been fed ensilage and good hay in the morning, with oat hay in reasonable abundance in the afternoon or evening. We have about ninety head of breeding ewes, including the lambs referred to, and they have been fed two grain sacks full of ensilage each day. This is not by any means heavy feeding, and it might be increased in quantity. This is a matter which we must learn from experience. We have fed the ensilage with care, not knowing what the results would be if fed heavily. Next winter we plan to add ensilage to the feed for our fattening flock. From the little experience we have had so far, we think the effects will be good, and that we shall be able to improve the quality of mutton by adding ensilage to the other feeds that we shall use in finishing our fattening flock."

The following interesting experience illustrating the value of silage for sheep-feeding is given by Mr. William Woods, a celebrated English breeder of Hampshire-Downs: "Last year, in August, I found myself with a flock of some 1,200 Hampshire-Down ewes, and about twelve or fourteen acres of swedes, on a farm of 4,000 acres, and these were all the roots there were to feed them and their lambs during the winter. Knowing how we should suffer from want of milk after lambing in January and February, I thought I would try (which no doubt has often been tried elsewhere, though not in this district) the effect of ensilage on ewes after lambing, having heard by hearsay that it increased the milk of cows nearly 30 per cent. I at once set to work to irrigate what water meadows I could spare, and in the month of October had a crop of grass that, had it been possible to make it into hay, would have made a ton of hay to the acre. I bought from the Aylesbury Dairy Company one of their Johnson's ensilage rick presses, and put some seventy or eighty tons of cut meadow grass under pressure. It must, however, be borne in mind that second cut water meadow grass is some of the poorest stuff that is consumed, either green or in hay,

and, therefore, my ensilage was not as good, and consequently not as favorable a trial, as if it had been made of better material.

"In January, when well into lambing, I opened the stack, and began to feed it to the ewes that had lambed. At first they hardly cared to eat it, but by degrees they seemed to like it more. They had a night and morning meal of best sainfoin hay, and a small lot of ensilage with the cake given at midday. After three weeks' trial what the shepherd observed was this: That when best sainfoin hay worth £4 a ton, was put up in the cages, and ensilage in the troughs at the same time, half the sheep would go to the hay and half to the ensilage, although there was sufficient accommodation for the whole flock at either sort, and we now observe that with the ewes that are most constant to the ensilage, their lambs are nourished better than the others. We have not lost a single lamb from scours, and have some 470 lambs from 380 ewes lambed as yet, which I think proves the value of the experiment. As soon as the stuff arrives in carts the ewes are crazy for it, and almost come over the hurdles, so eager are they to get at this new sort of feed, which, as I have stated, is only water meadow grass ensilage."

Silage for Swine.

The testimony concerning the value of silage as a food for swine is conflicting, both favorable and unfavorable reports being at hand. Many farmers have tried feeding it to their hogs, but without success. On the other hand, a number of hog-raisers have had good success with silage, and feed it regularly to their swine. It is possible that the differences in the quality of the silage and of the methods of feeding practiced explain the diversity of opinions formed concerning silage as hog food. According to Professor Cook, Col. F. D. Curtiss, the great American authority on the swine industry, states that silage is valuable to add to the winter rations

of our swine. Mr. J. W. Pierce of Indiana writes in regard to silage for hogs: "We have fed our sows, about twenty-five in number, for four winters, equal parts of ensilage and corn meal put into a cooker, and brought up to a steaming state. It has proved to be very beneficial to them. It keeps up the flow of milk of the sows that are nursing the young, equal to when they are running on clover. We find, too, when the pigs are farrowed, they become more robust, and take to nursing much sooner and better than they did in winters when fed on an exclusively dry diet. We also feed it to our sheep. To sixty head we put out about six bushels of ensilage." Dr. Bailey, the author of "The Book on Ensilage," fed large hogs ten pounds of silage, and one pound of wheat bran, with good results; the cost of the ration did not exceed 2 cents per day. He states that clover silage would be excellent, and would require no additional grain. Young pigs are exceedingly fond of silage. Feeding experiments conducted at Virginia Experiment Station show that silage is an economical maintenance feed for hogs, when fed in connection with corn, but not when fed alone.

In feeding silage to hogs, care should be taken to feed only very little, a pound or so, at the start, mixing it with corn meal, shorts, or other concentrated feeds. The diet of the hog should be largely made up of easily digested grain food; bulky, coarse feeds like silage can only be fed to advantage in small quantities, not to exceed three or four pounds per head, per day. As in case of breeding ewes, silage will give good results when fed with care to brood sows, keeping the system in order, and producing a good flow of milk.

Silage for Poultry.

But little experience is at hand as to the use of silage as a poultry food; some farmers, however, are feeding a little silage to their poultry with good success. Only small quantities should of course be fed, and it is beneficial as a stimulant and a regulator, as much as

food. A poultry raiser writes as follows in *Orange Judd Farmer*, concerning his experience in making and feeding silage to fowls. Devices similar to that here described have repeatedly been explained in the agricultural press: "Clover and corn silage is one of the best winter foods for poultry raisers. Let me tell you how to build four silos for \$1. Buy four coal-oil barrels at the drug store, burn them out on the inside, and take the heads out. Go to the clover field when the second crop of the small June clover is in bloom, and cut one-half to three-eighths of an inch in length, also one-half ton of sweet corn, and run this through the feed cutter. Put into the barrel a layer of clover, then a layer of corn. Having done this, take a common building jack-screw and press the silage down as firmly as possible. Then put on this a very light sprinkling of pulverized charcoal, and keep on putting in clover and corn until you get the barrel as full as will admit of the cover being put back. After your four barrel silos are filled, roll them out beside the barn, and cover them with horse manure, allowing them to remain there thirty days. Then put them away, covering with cut straw or hay. When the cold, chilling winds of December come, open one of these 'poultrymen's silos,' take about twenty pounds for one hundred hens, add equal parts of potatoes, ground oats, and winter rye, place same in a kettle and bring to a boiling state. Feed warm in the morning and the result will be that you will be enabled to market seven or eight dozen eggs per day from one hundred hens through the winter, when eggs bring good returns."

Additional Testimony as to the Value of Silage.

Corn Silage compared with root crops.—Root crops are not grown to any large extent in this country, but occasionally an old-country farmer is met with who grows roots for his stock, because his father did so, and his grandfather and great-grandfather before him. This is

what a well-known English writer, R. Henry Rew, says as to the comparative value of roots and silage, from the standpoint of an English farmer:

“The root crop has, for about a century and a half, formed the keystone of arable farming; yet it is the root crop whose position is most boldly challenged by silage. No doubt roots are expensive—say £10 per acre as the cost of producing an ordinary crop of turnips—and precarious, as the experience of the winter of 1887-8 has once more been notably exemplified in many parts of the country. In a suggestive article in the *Farming World Almanac* for 1888, Mr. Primrose McConnell discusses the question: ‘Are Turnips a Necessary Crop?’ and sums up his answer in the following definite conclusion:

“‘Everything, in short, is against the use of roots, either as a cheap and desirable food for any kind of live stock, as a crop suited for the fallow break, which cleans the land at little outlay, or as one which preserves or increases the fertility of the soil.’

“If the growth of turnips is abandoned or restricted ensilage comes in usually to assist the farmer in supplying their place. * * * When one comes to compare the cultivation of silage crops with that of roots, there are two essential points in favor of the former. One is their smaller expense, and the other is their practical certainty. The farmer who makes silage can make certain of his winter store of food, whereas he who has only his root crop may find himself left in the lurch at a time when there is little chance of making other provision.”

We have accurate information as to the yields and cost of production of roots and corn silage in this country from a number of American Experiment Stations. This shows that the tonnage of green or succulent feed per acre is not materially different in case of the two crops, generally speaking. But when the quantities of dry matter harvested in the crop are considered, the corn has been found to yield about twice as much as the ordinary root crops. According to data published by the Pennsyl-

vania Station, the cost of an acre of beets in the pit amounts to about \$56, and of an acre of corn in the silo about \$21, only half the quantities of food materials obtained, and at more than double the cost.

When the feeding of these two crops has been determined, as has been the case in numerous trials at experiment stations, it has been found that the dry matter of beets certainly has no higher, and in many cases has been found to have a lower value than that of corn silage; the general conclusion to be drawn, therefore, is that "beets cost more to grow, harvest and store, yield less per acre, and produce at best no more and no better milk or other farm product than corn silage."

Corn silage compared with hay. A ton and a half of hay per acre is generally considered a good average crop in humid regions. Since hay contains about 86 per cent. dry matter, a crop of $1\frac{1}{2}$ tons means 2,580 pounds of dry matter. Against this yield we have yields of 5,000 to 9,000 pounds of dry matter, or twice to three and a half times as much, in case of fodder corn. An average crop of green fodder will weigh twelve tons of Northern varieties and eighteen tons of Southern varieties. Estimating the percentage of dry matter in the former at 30 per cent., and in the latter at 20 per cent., we shall have in either case a yield of 7,200 pounds of dry matter. If we allow for 10 per cent of loss of dry matter in the silo there is still 6,500 pounds of dry matter to be credited to the corn. The expense of growing the corn crop is, of course, higher than that of growing hay, but by no means sufficiently so to offset the larger yields. It is a fact generally conceded by all who have given the subject any study, that the hay crop is the most expensive crop used for the feeding of our farm animals.

The late Sir John B. Lawes, of Rothamsted Experiment Station (England) said, respecting the relative value of hay and (grass) silage: "It is probable that when both (i. e., hay and silage) are of the very best quality that can be made, if part of the grass is cut and placed

in the silo, and another part is secured in the stack without rain, one might prove as good food as the other. But it must be borne in mind that while the production of good hay is a matter of uncertainty—from the elements of success being beyond the control of the farmer—good silage, by taking proper precautions, can be made with certainty.”

A few feeding experiments with corn silage vs. hay will be mentioned in the following:

In an experiment with milch cows conducted at the New Hampshire Station, the silage ration, containing 16.45 pounds of digestible matter, produced 21.0 pounds of milk, and the hay ration, containing 16.83 pounds digestible matter, produced 18.4 pounds milk; calculating the quantities of milk produced by 100 pounds of digestible matter in either case, we find on the silage ration, 127.7 pounds of milk, on the hay ration, 109.3 pounds, or 17 per cent. in favor of the silage ration.

In a feeding experiment with milch cows at the Maine Station, in which silage likewise was compared with hay, the addition of silage to the ration resulted in a somewhat increased production of milk solids, which was not caused by an increase in the digestible food materials eaten, but which must have been due either to the superior value of the nutriments of the silage over those of the hay or to the general psychological effect of feeding a great variety of foods. 8.8 pounds of silage proved to be somewhat superior to 1.98 pounds of hay (mostly timothy), the quantity of digestible material being the same in the two cases.

In another experiment, conducted at the same station, where silage was compared with hay for steers, a pound of digestible matter from the corn silage produced somewhat more growth than a pound of digestible matter from timothy hay. The difference was small, however, amounting in the case of the last two periods, where the more

accurate comparison is possible, to an increased growth of only 15 pounds of live weight for each ton of silage fed.

Corn Silage compared with fodder corn. The cost of production is the same for the green fodder up to the time of siloing, in case of both systems; as against the expense of siloing the crop comes that of shocking, and later on, placing the fodder under shelter in the field-curing process; further husking, cribbing, and grinding the corn, and cutting the corn stalks, since this is the most economical way of handling the crop, and the only way in which it can be fully utilized so as to be of as great value as possible for dry fodder. Professor King found the cost of placing corn in the silo to be 58.6 cents per ton, on the average for five Wisconsin farms, or, adding to this amount, interest and taxes on the silo investment, and insurance and maintenance of silo per ton, 73.2 cents. The expense of shocking and sheltering the cured fodder, and later cutting the same, will greatly exceed that of siloing the crop; to obtain the full value in feeding the ear corn, it must, furthermore, in most cases, be ground, costing ten cents or more a bushel of 70 lbs. The advantage is, therefore, decidedly with the siloed fodder in economy of handling, as well as in the cost of production.

The comparative feeding value of corn silage and fodder corn has been determined in a large number of trials at different experiment stations. The earlier ones of these experiments were made with only a couple of animals each, and no reliance can, therefore, be placed on the results obtained in any single experiment. In the later experiments a large number of cows have been included, and these have been continued for sufficiently long time to show what the animals could do on each feed.

A few experiments illustrating the value of silage as a stock food may be quoted. Prof. Henry fed two lots of steers on a silage experiment. One lot of four steers was fed on corn silage exclusively, and another similar

lot corn silage with shelled corn. The former lot gained 222 pounds in thirty-six days, and the latter lot 535 pounds, or a gain of 1.5 pounds per day per head for the silage-fed steers, and 3.7 pounds per day for the silage and shelled-corn-fed steers. Prof. Emery fed corn silage and cotton-seed meal, in the proportion of eight to one, to two three-year-old steers, at the North Carolina Experiment Station. The gain made during thirty-two days was, for one steer, 78 pounds, and for the other, 85.5 pounds, or 2.56 pounds per head per day.

The late well-known Wisconsin dairyman, Hon. Hiram Smith, in 1888 gave the following testimony concerning the value of silage for milch cows: "My silo was opened December 1st, and thirty pounds of ensilage was fed to each of the ninety cows for the night's feed, or 2,700 pounds per day, until March 10, one hundred days, or a total of 135 tons, leaving sufficient ensilage to last until May 10th. The thirty pounds took and well filled the place of ten pounds of good hay. Had hay been fed for the night's feed in place of the ensilage, it would have required 900 pounds per day for the ninety cows, or a total for the one hundred days of forty-five tons.

"It would have required, in the year 1887, forty-five acres of meadow to have produced the hay, which, if bought or sold, would have amounted to \$14.00 per acre. The 135 tons of ensilage were produced on $8\frac{1}{2}$ acres of land, and had a feeding value, as compared with hay, of \$74.11 per acre." As the conclusion of the whole matter, Mr. Smith stated that "three cows can be wintered seven months on one acre producing 16 tons of ensilage, while it required two acres of meadow in the same year of 1887 to winter one cow, with the same amount of ground feed in both cases."

Professor Shelton, formerly of Kansas Agricultural College, gives a powerful plea for silage in the following simple statement: "The single fact that the product of about two acres of ground kept our herd of fifty cattle

five weeks with no other feed of the fodder kind, except a small ration of corn fodder given at noon, speaks whole cyclopedias for the possibilities of Kansas fields when the silo is called in as an adjunct."

In conclusion. We will bring our discussions of the silo and its importance in American agriculture, to a close by quoting the opinions of a few recognized leaders on agricultural matters as to the value of silo and silage.

Says **Ex-Gov. Hoard**, the editor of *Hoard's Dairyman*, and a noted dairy lecturer: "For dairying of all the year around the silo is almost indispensable."

Prof. Hill, the director of Vermont Experiment Station: "It was long ago clearly shown that the most economical farm-grown carbohydrates raised in New England are derived from the corn plant, and that they are more economically preserved for cattle feeding in the silo than in any other way."

H. C. Wallace, editor *Creamery Gazette*: "While not an absolute necessity, the silo is a great convenience in the winter, and in times of protracted dryness almost a necessity in summer."

Prof. Carlyle, of Wisconsin Agricultural College: "A silo is a great labor-saving device for preserving the cheapest green fodder in the best form."

C. P. Goodrich, conductor of Farmers' Institutes in Wisconsin, and a well-known lecturer and authority on dairy topics: "A farmer can keep cows profitably without a silo, but he can make more profit with one, because he can keep his cows with less expense and they will produce more."

Prof. Deane, of Ontario Agricultural College: "The silo is becoming a greater necessity every year in Ontario."

Thus it will be seen that from all parts of the world wherever the silo is in use, the evidence points in favor of silage, there no longer being an argument against it,

in connection with the dairy, and especially in latitudes where corn can be grown.

Economy in production of feed materials means increased profits. Competition establishes the price at which the farmer and dairyman must market his products; but by the study of approved and modern methods the farmer can regulate his profits.

CHAPTER X.

A FEEDERS' GUIDE.

It has been thought best, in order to increase the usefulness of this little book to practical farmers, to add to the specific information given in the preceding as to the making and feeding of silage, a brief general outline of the main principles that should govern the feeding of farm animals. This will include a statement of the character of the various components of the feeding stuffs used for the nutrition of farm stock, with tables of composition, and a glossary of scientific agricultural terms often met with in agricultural papers, experiment station reports, and similar publications. Many of these terms are used constantly in discussions of agricultural topics, and unless the farmer has a fairly clear idea of their meaning the discussions will often be of no value to him. The information given in the following is put in as plain and simple language as possible, and only such facts are given as are considered of fundamental importance to the feeding of farm stock.

Composition of the Animal Body.

The most important components of the animal body are: water, ash, protein, and fat. We shall briefly describe these components:

Water is found in larger quantities in the animal body than any other substance. It makes up for about a third to nearly two-thirds of the live weight of farm animals. The fatter the animal is the less water is found in its body. We may consider 50 per cent. of the body weight a general average for the water content of the body of farm animals. When it comes to animal products used for food purposes, there are wide variations in the water content; from between 80 and 90 per cent. in case of milk, to between 40 and 60 per cent. in meat of various kinds, about 12 per cent. in butter, and less than 10 per cent. in fat salt pork.

Ash or mineral matter is that portion of the animal body which remains behind when the body is burned. The bones of animals contain large quantities of min-

eral matter, while the muscles and other parts of the body contain only small amounts; it must not be concluded, however, that the ash materials are of minor importance for this reason; both the young and full grown animals require a constant supply of ash materials in their food; if the food should not contain a certain minimum amount of ash materials, and of various compounds contained therein which are essential to life, the animal will turn sick very soon, and if the deficiency is not made up will die, no matter how much of other food components is supplied. As both ash and water are either present in sufficient quantities in feeding stuffs, or can be easily supplied, the feeder does not ordinarily need to give much thought to these components in the selection of foods for his stock.

Protein is not the name of any single substance, but for a large group of very complex substances that have certain characteristics in common, the more important of which is that they all contain the element **nitrogen**. Hence these substances are also known as **nitrogenous** components. The most important protein substances found in the animal body are: lean meat, fibrin, all kinds of tendons, ligaments, nerves, skin, brain, in fact the entire working machinery of the animal body. The casein of milk and the white of the egg are, furthermore, protein substances. It is evident from the enumeration made that protein is to the animal body what the word implies, the most important, the first.

Fat is a familiar component of the animal body; it is distributed throughout the body in ordinary cases, but is found deposited on certain organs, or under the skin, in thick layers, in the case of very fat animals.

The animal cannot, as is well known, live on air; it must manufacture its body substances and products from the food it eats, hence the next subject for consideration should be:

Composition of Feeding Stuff.

The feeding stuffs used for the nutrition of our farm animals are composed of similar compounds as those which are found in the body of the animal itself, although the components in the two cases are rarely identical, but can be distinguished from each other in most cases by certain chemical reactions. The animal body through its vital functions has the faculty of changing the various food substances which it finds in the food in such a way

that they are in many instances different from any substances found in the vegetable world.

The components of feeding stuffs which are generally enumerated and taken into account in ordinary chemical fodder analysis, or in discussions of feeding problems are **Water** (or **Moisture**, as it is often called), **ash materials**, **fat** (or **ether-extract**), **protein**, **crude fiber**, and **nitrogen-free extract**; the two components last given are sometimes grouped together under the name **Carbohydrates**. These components are in nearly all cases mixtures of substances that possess certain properties in common; and as the mixtures are often made up of different components, or of the same components in varying proportions, it follows that even if a substance is given in a table of composition of feeding stuffs, in the same quantities in case of two different feeds, these feeds do not necessarily have the same food value as far as this component alone is concerned.

Water or **moisture** is found in all feeding stuffs, whether succulent or apparently dry. Green fodders contain from 60 to 90 per cent. of water, according to the stage of maturity of the fodder; root crops contain between 80 and 90 per cent., while hay of different kinds, straw, and concentrated feeds ordinarily have water contents ranging between 15 and 8 per cent.

Ash or **mineral matter** is found in all plant tissues and feeding stuffs. We find most ash in leafy plants, or in refuse feeds made up from the outer covering of grains or other seeds, viz., from 4 to 8 per cent.; less in the cereals and green fodder, and least of all in roots. A fair amount of ash materials is a necessity in feeding young stock and pregnant animals, and only limited amount of foods low in ash should be fed to such animals; refuse feed from starch and glucose factories which have been treated with large quantities of water should, therefore, be fed with care in such cases.

Fat or **ether-extract** is the portion of the feeding stuff which is dissolved by ether or benzine. It is found in large quantities in the oil-bearing seeds, more than one-third of these being composed of oil or fat; the oil-mill refuse feeds are also rich in fat, especially cotton seed meal and old-process linseed meal; other feeds rich in fat are gluten meal and feed, grano-gluten and rice meal. The ether-extract of the coarse fodders contains considerable wax, resins, and other substances which have a low feeding value, while that of the seeds and by-products from these are essentially pure fat or oil.

Protein or flesh forming substances are considered of the highest importance in feeding animals, because they supply the material required for building up the tissues of the body, and for maintaining these under the wear caused by the vital functions. Ordinarily the feed rations of most farmers are deficient in protein since most of the farm-grown foods (not including clover, alfalfa, peas and similar crops) contain only small amounts of these substances. The feeding stuffs richest in protein are, among the coarse foods, those already mentioned; among the concentrated foods: cottonseed meal, linseed meal, gluten meal, gluten feed, grano-gluten, buckwheat, middlings, and the flour-mill, brewery, and distillery refuse feeds. The protein substances are also called **nitrogenous** bodies for the reasons given above, and the other **organic** (combustible) components in the feeding stuffs are spoken of as **non-nitrogenous** substances. The non-nitrogenous components of feeding stuffs, therefore, include fat and the two following groups, crude fiber and nitrogen-free extract.

Crude fiber is the framework of the plants, forming the walls of the cells. It is usually the least digestible portion of plants and vegetable foods, and the larger proportion present thereof the less valuable the food is. We find, accordingly, that the fodders containing most crude fiber are the cheapest foods and least prized among feeders, as, e. g., straw of the various cereal and seed-producing crops, corncobs, oats and rice hulls, cotton-seed hulls, buckwheat hulls, and the like. These feeding stuffs, in so far as they can be considered as such, contain as a rule between 35 and 50 per cent. of crude fiber. Concentrated feeding stuffs, on the other hand, often contain less than 5 per cent. of crude fiber, and in the cereals only a couple of per cent. of crude fiber are found.

Nitrogen-free extract is a general name for all that is left of the organic matter of plants and fodders after deducting the preceding group of compounds. It includes some of the most valuable constituents of feeding stuffs, which make up the largest bulk of the food materials; first in importance among these constituents are starch and sugar, and, in addition, a number of less well-known substances of similar compositions, like pentosans, gums, organic acids, etc. Together with crude fiber the nitrogen-free extract forms the group of substances known as **carbohydrates**. A general name for carbohydrates is **heat-producing substances**, since this is one important function which they fill; they are not as valuable for

this purpose, pound for pound, as fat, which also is often used for the purpose by the animal organism, but on account of the large quantities in which the carbohydrates are found in most feeding stuffs they form a group of food materials second to none in importance. Since it has been found that fat will produce about $2\frac{1}{2}$ times as much heat as carbohydrates on combustion, the two components are often considered together in tables of composition of feeding stuffs and discussion of the feeding value of different foods, the per cent. of fat being multiplied by $2\frac{1}{4}$ in such cases, and added to the per cent. of carbohydrates (i. e., crude fiber plus nitrogen-free extract) in the foods. As this renders comparisons much easier, and simplifies discussions for the beginner, we shall adopt this plan in the tables and discussions given in this Guide.

Carbohydrates and fat not only supply heat on being oxidized or burned in the body, but also furnish materials for energy used in muscular action, whether this be voluntary or involuntary. They also in all probability are largely used for the purpose of storing fatty tissue in the body of fattening animals, or of other animals that are fed an excess of nutrients above what is required for the production of the necessary body heat and muscular force.

To summarize briefly the use of the various food elements: Protein is required for building up muscular tissue, and to supply the breaking down and waste of nitrogenous components constantly taking place in the living body. If fed in excess of this requirement it is used for production of heat and energy. The non-nitrogenous organic components, i. e., carbohydrates and fat, furnish material for supply of heat and muscular exertion, as well as for the production of fat in the body or in the milk, in case of milch cows giving milk.

Digestibility of foods. Only a certain portion of a feeding stuff is of actual value to the animal, viz., the portion which the digestive juices of the animal can render soluble, and thus bring into a condition in which the system can make the use of it called for; this digestible portion ranges from half or less to more than 96 per cent. in case of highly digestible foods. The rest is simply ballast, and the more ballast, i. e., the less of digestible matter a food contains, the more the value of the digestible portion is reduced. Straw, e. g., is found, by means of digestion experiments, to contain between 30 and 40 per cent. of digestible matter in all, but it is very doubtful whether an animal can be kept alive

for any length of time when fed straw alone. It very likely costs him more effort to extract the digestible matter therefrom than the energy this can supply. An animal lives on and produces not from what he eats but from what he digests.

Relative value of feeding stuffs. Since the price of different feeding stuffs varies greatly with the locality and season, it is impossible to give definite statements as to the relative economy which will hold good always; it may be said, in general, that the feeding stuffs richest in protein are our most costly and at the same time our most valuable foods. Experience has shown to a certainty that a liberal supply of protein is an advantage in feeding most classes of farm animals, so that if such feeding stuffs can be obtained at fair prices, it will pay to feed them quite extensively, and they must enter into all food rations in fair quantities in order that the animals may produce as much milk, meat, or other farm products, as is necessary to render them profitable to their owner. The following statement shows a classification of feeding stuffs which may prove helpful in deciding upon kinds and amounts of feeds to be purchased or fed.

CLASSIFICATION OF CATTLE FOODS.

COARSE FEEDS.

1	2	3
Low in protein. High in carbohydrates. 50 to 65 per cent. digestible.	Medium in protein. Medium in carbohydrates. 55 to 65 per cent. digestible.	Low in protein. High in carbohydrates. 85 to 95 per cent. digestible.
Hays, straws, corn fodder, corn stover, silage, cereal fodders.	Clovers, pasture grass, vetches, pea and bean fodder.	Carrots, potatoes, sugar beets, mangolds, turnips.

CLASSIFICATION OF CATTLE FOODS—CONTINUED.

Very high protein (above 40 per cent.)	High in protein (25-40 per ct.)	Fairly high in protein (12-25 per ct.)	Low in protein (below 12 per cent.)
Dried blood. Meat scraps. Cotton-seed meal.	Gluten meal. Atlas meal. Linseed meal. Buckwheat middlings. Buckwheat shorts. Soja-bean. Grano-gluten.	Malt sprouts. Dried brewers' grains. Gluten feed. Cow pea. Pea meal. Wheat shorts. Rye shorts. Oat shorts. Wheat middlings. Wheat bran. Low-grade flour.	Wheat. Barley. Oats. Rye. Corn. Rice polish. Rice. Hominy chops. Germ meal. Oat feeds.

Feeding Standards.

Investigations by scientists have brought to light the fact that the different classes of farm animals require certain amounts of food materials for keeping the body functions in regular healthy activity; this is known as the maintenance ration of the animal, an allowance of feed which will cause him to maintain his live weight without either gaining or losing, or producing animal products like milk, wool, meat, eggs, etc. If the animal is expected to manufacture these products in addition, it is necessary to supply enough extra food to furnish materials for this manufacture. The food requirements for different purposes have been carefully studied, and we know now with a fair amount of accuracy how much food it takes in the different cases to reach the objects sought. Since there is a great variety of different foods, and almost infinite possible combinations of these, it would not do to express these requirements in so and so many pounds of corn or oats, or wheat bran, but they are in all cases expressed in amounts of digestible protein, carbohydrates and fat. This enables the feeder to supply these food materials in such feeding stuffs as he

has on hand or can procure. The feeding standards commonly adopted as basis for calculations of this kind are those of the German scientists, Wolff and Lehmann. Those standards give, then, the approximate amount of dry matter, digestible protein, carbohydrates, and fat which the different classes of farm animals should receive in their daily food in order to produce maximum returns. We have seen that a fair amount of digestible protein in the food is essential in order to obtain good results. The proportion of digestible nitrogenous to digestible non-nitrogenous food substances therefore becomes important. This proposition is technically known as **Nutritive Ration**, and we speak of **wide nutritive ratio**, when there are six or more times as much digestible carbohydrates and fat in a ration as there is digestible protein, and a **narrow ratio**, when the proportion of the two kinds of food materials is as 1 to 6, or less.

The feeding standards given in the following tables may serve as a fairly accurate guide in determining the food requirements of farm animals; and it will be noticed that the amounts are per 1,000 pounds live weight, and not per head, except as noted in the case of growing animals. They should not be looked upon as infallible guides, which they are not, for the simple reason that different animals differ greatly both in the amounts of food that they consume and in the uses which they are able to make of the food they eat. The feeding standard for milch cows has probably been subjected to the closest study by American experiment station workers, and it has been found in general that the Wolff-Lehmann standard calls for more digestible protein (i. e., a narrower nutritive ratio) than can be fed with economy in most of the dairy sections of our country, at least in the central and northwestern states. On basis of investigations conducted in the early part of the nineties, along this line, Prof. Woll, of Wisconsin, proposed a so-called **American practical feeding ration**, which calls for the following amount of digestible food materials in the daily ration of a dairy cow of an average weight of 1,000 pounds.

Digestible protein.....	2.2 lbs.	} carbohydrates+fat ×2¼, 14.9 lbs. protein+carbohy- drates+fat×2¼.
Digestible Carbohydrates..	13.3 lbs.	
Digestible fat.....	.7 lbs.	
Total digestive matter.....	17.1 lbs.	
Nutritive ratio.....	1:6.9	

FEEDING STANDARDS FOR FARM ANIMALS.

(WOLFF-LEHMANN.)

Per day and per 1000 lbs. live weight.

	Total Dry Substance.	Nutritive (Digestible) Substances.			Total Nutritive Substances.	Nutritive Ratio.
		Crude Protein.	Carbo-hydrates.	Ether Extract.		
	lbs.	lbs.	lbs.	lbs.	lbs.	
1. Steers at rest in stall.....	18	0.7	8.0	0.1	8.9	1:11.8
" slightly worked.....	22	1.4	10.0	0.3	12.1	1: 7.7
" moderately worked.....	25	2.0	11.5	0.5	14.7	1: 6.5
" heavily worked.....	28	2.8	13.0	0.8	17.7	1: 5.3
2. Fattening steers, 1st period.....	30	2.5	15.0	0.5	18.7	1: 6.5
" " 2nd ".....	30	3.0	14.5	0.7	19.2	1: 5.4
" " 3d ".....	26	2.7	15.0	0.7	19.4	1: 6.2
3. Milch cows, daily milk yield, 11 lbs.	25	1.6	10.0	0.3	12.3	1: 6.7
" " " " " 16.5 ".....	27	2.0	11.0	0.4	14.0	1: 6.0
" " " " " 22 ".....	29	2.5	13.0	0.5	16.7	1: 5.7
" " " " " 27.6 ".....	32	3.3	13.0	0.8	18.2	1: 4.5
4. Wool sheep, coarser breeds.....	20	1.2	10.5	0.2	12.2	1: 9.1
" " finer ".....	23	1.5	12.5	0.3	14.2	1: 8.5
5. Breeding ewes, with lambs.....	25	2.9	15.0	0.5	19.1	1: 5.6
6. Fattening sheep, 1st period.....	30	3.0	18.0	0.5	19.2	1: 5.4
" " 2nd ".....	26	3.5	14.0	0.6	19.4	1: 4.5
7. Horses lightly worked.....	20	1.5	9.5	0.4	12.0	1: 7.0
" moderately worked.....	24	2.0	11.0	0.6	14.5	1: 6.2
" heavily worked.....	26	2.5	13.3	0.8	17.7	1: 6.0
8. Brood sows, with pigs.....	22	2.5	15.5	0.4	19.0	1: 6.6
9. Fattening swine, 1st period.....	36	4.5	25.0	0.7	31.2	1: 5.9
" " 2nd ".....	32	4.0	24.0	0.5	29.2	1: 6.3
" " 3d ".....	25	2.7	18.0	0.4	22.0	1: 7.0
10. Growing cattle:						
		DAIRY BREEDS.				
		Avr. Live Weight Per Head.				
Age, Months.						
2- 3	154 lbs.....	23	4.0	13.0	2.0	21.8 1: 4.5
3- 6	309 ".....	24	3.0	12.8	1.0	18.2 1: 5.1
6-12	507 ".....	27	2.0	12.5	0.5	15.7 1: 6.8
12-18	705 ".....	26	1.8	12.5	0.4	15.3 1: 7.5
18-24	882 ".....	26	1.5	12.0	0.3	14.2 1: 8.5

FEEDING STANDARDS FOR FARM ANIMALS—CONTINUED.

		Total Dry Substance.	Nutritive (Digestible) Substances.			Total Nutritive Substances.	Nutritive Ratio.
			Crude Protein.	Carbo- hydrates.	Ether Extract.		
		lbs.	lbs.	lbs.	lbs.	lbs.	
11. Growing cattle:							
BEEF BREEDS.							
<i>Age, Months.</i>	<i>Avr. Live Weight Per Head.</i>						
2- 3	165 lbs.....	23	4.2	13.0	2.0	20.0	1:4.2
3- 6	331 ".....	24	3.5	12.8	1.5	19.9	1:4.7
6-12	551 ".....	25	2.5	13.2	0.7	14.4	1:6.0
12-18	750 ".....	24	2.0	12.5	0.5	15.7	1:6.8
18-24	937 ".....	24	1.8	12.0	0.4	14.8	1:7.2
12. Growing sheep:							
WOOL BREEDS.							
4- 6	60 lbs.....	25	3.4	15.4	0.7	20.5	1:5.0
6- 8	75 ".....	25	2.8	13.8	0.6	18.0	1:5.4
7-11	84 ".....	23	2.1	11.5	0.5	14.8	1:6.0
11-15	90 ".....	22	1.8	11.2	0.4	14.0	1:7.0
15-20	99 ".....	22	1.5	10.8	0.3	13.0	1:7.7
13. Growing sheep:							
MUTTON BREEDS.							
4- 6	66 lbs.....	26	4.4	15.5	0.9	22.1	1:4.0
6- 8	84 ".....	26	3.5	15.0	0.7	20.2	1:4.8
8-11	101 ".....	24	3.0	14.3	0.5	18.5	1:5.2
11-15	121 ".....	23	2.2	12.6	0.5	16.0	1:6.3
15-20	154 ".....	22	2.0	12.0	0.4	15.0	1:6.5
14. Growing swine:							
BREEDING ANIMALS.							
2- 3	44 lbs.....	44	7.6	28.0	1.0	38.0	1:4.0
3- 5	99 ".....	35	5.0	23.1	0.8	30.0	1:5.0
5- 6	121 ".....	32	3.7	21.3	0.4	26.0	1:6.0
6- 8	176 ".....	25	2.8	18.7	0.3	22.2	1:4.0
8-12	265 ".....	25	2.1	15.3	0.2	17.9	1:7.5
15. Growing fat pigs:							
2- 3	44 lbs.....	44	7.6	28.0	1.0	38.0	1:4.0
3- 5	110 ".....	35	5.0	23.1	0.8	30.0	1:5.0
5- 6	143 ".....	33	4.3	22.3	0.6	28.0	1:5.5
6- 8	198 ".....	30	3.6	20.5	0.4	25.1	1:6.0
8-12	287 ".....	26	3.0	18.3	0.3	22.0	1:6.4

How to Figure Out Rations.

We shall use the practical American feeding ration as a basis for figuring out the food materials which should be supplied a dairy cow weighing 1,000 pounds; in order to insure a maximum and economical production of milk and butter fat from her. We shall suppose that a farmer has the following foods at his disposal: corn silage, mixed timothy and clover hay, and wheat bran; and that he has to feed about forty pounds of silage per head daily, in order to have it last through the winter and spring. We will suppose that he gives his cows in addition five pounds of hay and about six pounds of bran. If we now look up in the tables given on pages 211 to 215, the amounts of digestible food components contained in the quantities given of these feeds, we shall have:

	Total Dry Mtr.	Digestible Pro. Carb. & fat.		Total Dig. Mtr.	Nut. Ratio.
40 lbs. corn silage,	10.5 lbs.	.48 lbs.	7.1 lbs.	7.58	
5 lbs. mixed hay,	4.2	.22	2.2	2.42	
6 lbs. wheat bran,	5.3	.72	2.8	3.52	
	<hr/> 20.0	<hr/> 1.42	<hr/> 12.1	<hr/> 13.52	1: 8.5

We notice that the ration as now given contains too little total digestible matter, there being a deficit of both digestible protein, carbohydrates and fat, it will evidently be necessary to supply at least a couple of pounds more of some concentrated feed, and preferably of a feed rich in protein, since the deficit of this component is proportionately greater than that of the other components. In selecting a certain food to be added and deciding the quantities to be fed the cost of different available foods must be considered. We will suppose that linseed meal can be bought at a reasonable price in this case, and will add two pounds thereof to the ration. We then have the following amounts of digestible matter in the ration:

	Total Dry Mtr.	Digestible Pro. Carb. & fat.		Total Dig. Mtr.	Nut. Ratio.
Ration as above,	20.0 lbs.	1.42 lbs.	12.1 lbs.	13.25	1:6.4
2 lbs. oil meal(O.P.)	1.8	.62	1.0	1.62	
Total,	<hr/> 21.8	<hr/> 2.04	<hr/> 13.1	<hr/> 16.14	1:6.4
Amer. prac. feeding ration,		2.2	14.9	17.1	1:6.9
Wolff-Lehman standard,	29.0	2.5	14.1	16.6	1:5.7

The new ration is still rather light, both in total and digestible food materials; for many cows it might prove effective as it is, while for others it would doubtless be improved by a further addition of some concentrated food medium rich in protein, or if grain feeds are high, of more hay or silage. The feeding rations are not intended to be used as infallible standards that must be followed blindly, nor could they be used as such. They are not only meant to be approximate gauges by which the farmer may know whether the ration which he is feeding is of about such a composition and furnishes such amount of important food materials are most likely to produce best results, cost of feed and returns in products as well as condition of animals being all considered.

In constructing rations according to the above feeding standard, several points must be considered besides the chemical composition and the digestibility of the feeding stuffs; the standard cannot be followed directly without regard to bulk and other properties of the fodder; the ration must not be too bulky, and still must contain a sufficient quantity of roughage to keep up the rumination of the animals, in case of cows and sheep, and to secure a healthy condition of the animals generally. The local market prices of cattle foods are of the greatest importance in determining which foods to buy; the conditions in the different sections of our great continent differ so greatly in this respect that no generalizations can be made. Generally speaking, nitrogenous concentrated feeds are the cheapest feeds in the south and in the east, and flour-mill, brewery, and starch-factory refuse feeds the cheapest in the northwest.

The tables given on pages 211 to 215 will be found of great assistance in figuring out the nutrients in feed rations; the tables have been reproduced from a bulletin published by the Vermont Experiment Station, and are based upon the latest compilations of analyses of feeding stuffs. A few rations are given in the following as samples of combinations of different kinds of feed with corn silage that will produce good results with dairy cows. The rations given on page 171 may also be studied to advantage in making up feed rations with silage for dairy cows. The Experiment Stations or other authorities publishing the rations are given in all cases.

GRAIN MIXTURE FOR DAIRY COWS.

Mixtures to be fed with one bushel of silage and hay, or with corn stover or hay.

Massachusetts Experiment Station.

1	2
100 lbs. bran. 100 lbs. flour and middlings. 150 lbs. gluten feed. Mix and feed 7 quarts daily.	100 lbs. bran or mixed feed. 150 lbs. gluten feed. Mix and feed 9 quarts daily.
3	4
100 lbs. bran. 100 lbs. flour middlings. 100 lbs. gluten or cottonseed meal. Mix and feed 7 to 8 quarts daily.	200 lbs. malt sprouts. 100 lbs. bran. 100 lbs. gluten feed. Mix and feed 10 to 12 qts. daily
5	6
100 lbs. cottonseed or gluten meal. 150 lbs. corn and cob meal. 100 lbs. bran. Mix and feed 7 to 8 quarts daily.	125-lbs. gluten feed. 100 lbs. corn and cob meal. Mix and feed 5 to 6 qts. daily.

New Jersey Experiment Station: (1) 40 lbs. corn silage, 5 lbs. gluten feed, 5 lbs. dried brewers' grains, 2 lbs. wheat bran.

(2) 35 lbs. corn silage, 5 lbs. mixed hay, 5 lbs. wheat bran, 2 lbs. each of oil meal, gluten meal and hominy meal.

(3) 40 lbs. corn silage, 5 lbs. clover hay, 3 lbs. wheat bran, 2 lbs. malt sprouts, 1 lb. each of cottonseed meal and hominy meal.

(4) 40 lbs. corn silage, 4 lbs. dried brewers' grain, 4 lbs. wheat bran, 2 lbs. oil meal.

Maryland Experiment Station: (1) 40 lbs. silage, 5 lbs. clover hay, 9 lbs. wheat middlings, and 1 lb. gluten meal.

(2) 30 lbs. silage, 8 lbs. corn fodder, 6 lbs. cow pea hay, 3 lbs. bran, 2 lbs. gluten meal.

Michigan Experiment Station: (1) 40 lbs. silage, 8 lbs. mixed hay, 8 lbs. bran, 3 lbs. cottonseed meal.

(2) 30 lbs. silage, 5 lbs. mixed hay, 4 lbs. corn meal, 4 lbs. bran, 2 lbs. cottonseed meal, 2 lbs. oil meal.

(3) 30 lbs. silage, 10 lbs. clover hay, 4 lbs. bran, 4 lbs. corn meal, 3 lbs. oil meal.

(4) 30 lbs. silage, 4 lbs. clover hay, 10 lbs. bran.

Kansas Experiment Station: (1) Corn silage 40 lbs., 10 lbs. prairie hay or millet, $4\frac{1}{4}$ lbs. bran, 3 lbs. cottonseed meal.

(2) 40 lbs. corn silage, 10 lbs. corn fodder, 4 lbs. bran, 2 lbs. Chicago gluten meal, 2 lbs. cottonseed meal.

(3) 40 lbs. corn silage, 5 lbs. sorghum hay, 3 lbs. corn, $1\frac{1}{2}$ lbs. bran, 3 lbs. gluten meal, $1\frac{1}{2}$ lbs. cottonseed meal.

(4) 30 lbs. corn silage, 10 lbs. millet, 4 lbs. corn, 1 lb. gluten meal, 3 lbs. cottonseed meal.

(5) 30 lbs. corn silage, 15 lbs. fodder corn, $2\frac{1}{2}$ lbs. bran, 3 lbs. gluten meal, $1\frac{1}{2}$ lbs. cottonseed meal.

(6) 30 lbs. corn silage, 15 lbs. fodder corn, $2\frac{1}{2}$ lbs. bran, 3 lbs. gluten meal, $1\frac{1}{2}$ lbs. cottonseed meal.

($6\frac{1}{2}$) 30 lbs. corn silage, 10 lbs. oats straw, 2 lbs. oats, 4 lbs. bran, 2 lbs. gluten meal, 2 lbs. cottonseed meal.

(7) 20 lbs. corn silage, 20 lbs. alfalfa, 3 lbs. corn.

(8) 15 lbs. corn silage, 20 lbs. alfalfa, 5 lbs. Kafir corn.

(9) 20 lbs. corn silage, 15 lbs. alfalfa, 4 lbs. corn, 3 lbs. bran.

(10) 40 lbs. corn silage, 5 lbs. alfalfa, 3 lbs. corn, 3 lbs. oats, 2 lbs. O. P. linseed meal, 1 lb. cottonseed meal.

Tennessee Experiment Station: 30 lbs. silage, 10 lbs. clover or cow pea hay, 5 lbs. wheat bran, 3 lbs. of corn, 2 lbs. cotton seed meal.

North Carolina Experiment Station: (1) 40 lbs. corn silage, 10 lbs. cottonseed hulls, 5 lbs. cottonseed meal.

(2) 50 lbs. corn silage, 5 lbs. orchard grass hay, $4\frac{1}{2}$ lbs. cottonseed meal.

(3) 30 lbs. corn silage, 10 lbs. alfalfa, 6 lbs. wheat bran, 5 lbs. cottonseed hulls.

(4) 40 lbs. corn silage, 15 lbs. cow pea vine hay.

(5) 40 lbs. corn silage, 6 lbs. wheat bran, 6 lbs. field peas ground.

(6) 40 lbs. corn silage, 4 lbs. cut corn fodder, 3 lbs. ground corn, 4 lbs. bran, 1 lb. cottonseed meal (ration fed at Biltmore Estate to dairy cows. Silage is fed to steers and cows, and corn, peas, teosinte, cow peas, millet and crimson clover are used as silage crops. These crops are put into the silo in alternate layers. "Will never stop using the silo and silage.")

South Carolina: 30 lbs. corn silage, 6 lbs. bran, 3 lbs. cottonseed meal, 12 lbs. cottonseed hulls.

Georgia Experiment Station: 40 lbs. corn silage, 15 lbs. cow pea hay, 5 lbs. bran.

Ontario Agr. College: 45 lbs. corn silage, 6 lbs. clover hay, 8 lbs. bran, 2 lbs. barley.

Nappan Experiment Station (Canada): 30 lbs. corn silage, 20 lbs. hay, 8 lbs. bran and meal.

The criticism may properly be made with a large number of the rations given in the preceding, that it is only in case of low prices of grain or concentrated feeds in general, and with good dairy cows, that it is possible to feed such large quantities of grain profitably as those often given. In the central and northwestern states it will not pay to feed grain heavily with corn at fifty cents a bushel and oats at thirty cents a bushel or more. In times of high prices of feeds, it is only in exceptional cases that more than six or eight pounds of concentrated

AVERAGE COMPOSITION OF SILAGE CROPS OF DIFFERENT KINDS, IN PER CENT.

	Water.	Ash.	Crude Protein	Crude Fibre.	Nitro- gen- Free Extract	Ether Extract
Corn Silage—						
Mature corn.....	73.7	1.6	2.2	6.5	15.1	.9
Immature corn	79.1	1.4	1.7	6.0	11.0	.8
Ears removed.....	80.7	1.8	1.8	5.6	9.5	.6
Clover silage	72.0	2.6	4.2	8.4	11.6	1.2
Soja bean silage	74.2	2.8	4.1	9.7	6.9	2.2
Cow-pea vine silage..	79.3	2.9	2.7	6.0	7.6	1.5
Field-pea vine silage.	50.0	3.6	5.9	13.0	26.0	1.6
Corn cannery refuse- husks.....	83.8	.6	1.4	5.2	7.9	1.1
Corn cannery refuse- cobs.....	74.1	.5	1.5	7.9	14.3	1.7
Pea cannery refuse ..	76.8	1.3	2.8	6.5	11.3	1.3
Sorghum silage	76.1	1.1	.8	6.4	15.3	.3
Corn-soja bean silage	76.0	2.4	2.5	7.2	11.1	.8
Millet-soja bean silage	79.0	2.8	2.8	7.2	7.2	1.0
Rye silage.....	80.8	1.6	2.4	5.8	9.2	.3
Apple pomace silage..	85.0	.6	1.2	3.3	8.8	1.1
Cow-pea and soja bean mixed.....	69.8	4.5	3.8	9.5	11.1	1.3
Corn kernels	41.3	1.0	6.0	1.5	46.6	3.6
Mixed grasses (rowen)	18.4	7.1	10.1	22.8	36.0	5.7
Brewers' grain silage.	69.8	1.2	6.6	4.7	15.6	2.1

feeds can be fed with economy per head daily. Some few cows can give proper returns for more than this quantity of grain even when this is high, but more cows will not do so. The farmer should aim to grow protein foods like clover, alfalfa, peas, etc., to as large extent as practicable, and thus reduce his feed bills.

The table on preceding page gives actual chemical analyses of the products mentioned and includes the entire 100 per cent of the contents and weight. The following table, compiled by the Editors of Hoard's Dairyman, Fort Atkinson, Wis., shows the average amount of digestible nutrients in the more common American fodders, grains and by-products, and is the table that should be used in formulating rations. The tables give the amounts of digestible nutrients contained in 100 lbs. in pounds, and the figures can, therefore, be taken as per cents in figuring out the amount of digestible nutrients in any given amount of food material, and it is by such methods that the tables given on pages 211 to 215 are obtained.

Compiled by the editors of Hoard's Dairyman, Fort Atkinson, Wis.

ANALYSES OF FEEDING STUFFS.

TABLE SHOWING AVERAGE AMOUNTS OF DIGESTIBLE NUTRIENTS IN THE MORE COMMON AMERICAN FODDERS, GRAINS AND BY-PRODUCTS.

(Compiled by the Editors of Hoard's Dairyman, Fort Atkinson, Wis.)

NAME OF FEED.	DRY MATTER IN 100 POUNDS.	DIGESTIBLE NUTRIENTS IN 100 POUNDS.		
		Protein	Carbo- hydrates.	Ether Extract, (Crude Fat.)
GREEN FODDERS.	Lbs.	Lbs.	Lbs.	Lbs.
Pasture Grasses, mixed.....	20.0	2.5	10.2	0.5
Fodder Corn	20.7	1.0	11.6	0.4
Sorghum.....	20.6	0.6	12.2	0.4
Red Clover.....	29.2	2.9	14.8	0.7
Alfalfa.....	28.2	3.9	12.7	0.5
Cow Pea.....	16.4	1.8	8.7	0.2
Soja Bean.....	24.9	3.2	11.0	0.5
Oat Fodder	37.8	2.6	18.9	1.0
Rye Fodder	23.4	2.1	14.1	0.4
Rape	14.0	1.5	8.1	0.2
Peas and Oats	16.0	1.8	7.1	0.2
Beet Pulp	10.2	0.6	7.3	...

NAME OF FEED.	DRY MATTER IN 100 POUNDS.	DIGESTIBLE NUTRIENTS IN 100 POUNDS.		
		Protein	Carbo- hydrates	Ether Extract (Crude Fat)
SILAGE.				
Corn.....	20.9	0.9	11.3	0.7
Corn, Wisconsin analyses..	26.4	1.3	14.0	0.7
Sorghum.....	23.9	0.6	14.9	0.2
Red Clover.....	28.0	2.0	13.5	1.0
Alfalfa.....	27.5	3.0	8.5	1.9
Cow Pea.....	20.7	1.5	8.6	0.9
Soja Bean.....	25.8	2.7	8.7	1.3
DRY FODDERS AND HAY.				
Corn Fodder.....	57.8	2.5	34.6	1.2
Corn Fodder, Wis. analyses.	71.0	3.7	40.4	1.2
Corn Stover.....	59.5	1.7	32.4	0.7
Sorghum Fodder.....	59.7	1.5	37.3	0.4
Red Clover.....	84.7	6.8	35.8	1.7
Alfalfa.....	91.6	11.0	39.6	1.2
Barley.....	85.2	6.2	46.6	1.5
Blue Grass.....	78.8	4.8	37.3	2.0
Cow Pea.....	89.3	10.8	38.6	1.1
Crab Grass.....	82.4	5.7	39.7	1.4
Johnson Grass.....	87.7	2.4	47.8	0.7
Marsh Grass.....	88.4	2.4	29.9	0.9
Millet.....	92.3	4.5	51.7	1.3
Oat Hay.....	91.1	4.3	46.4	1.5
Oat and Pea Hay.....	85.4	9.2	36.8	1.2
Orchard Grass.....	90.1	4.9	42.3	1.4
Prairie Grass.....	87.5	3.5	41.8	1.4
Red Top.....	91.1	4.8	46.9	1.0
Timothy.....	86.8	2.8	43.4	1.4
Timothy and Clover.....	85.3	4.8	39.6	1.6
Vetch.....	88.7	12.9	47.5	1.4
White Daisy.....	85.0	3.8	40.7	1.2
STRAW.				
Barley.....	85.8	0.7	41.2	0.6
Oat.....	90.8	1.2	38.6	0.8
Rye.....	92.9	0.6	40.6	0.4
Wheat.....	90.4	0.4	36.3	0.4

NAME OF FEED.	DRY MATTER IN 100 POUNDS, %	DIGESTIBLE NUTRIENTS IN 100 POUNDS.		
		Protein.	Carbo- hydrates.	Ether Extract (Crude Fat.)
ROOTS AND TUBERS.				
	4Lbs.	Lbs.	Lbs.	Lbs.
Artichokes	20.0	2.0	16.8	0.2
Beets, common	13.0	1.2	8.8	0.1
Beets, sugar.....	13.5	1.1	10.2	0.1
Carrots	11.4	0.8	7.8	0.2
Mangels.....	9.1	1.1	5.4	0.1
Parsnips	11.7	1.6	11.2	0.2
Potatoes	21.1	0.9	16.3	0.1
Rutabagas.....	11.4	1.0	8.1	0.2 ³
Turnips	9.5	1.0	7.2	0.2
Sweet Potatoes	29.0	0.9	22.2	0.3
GRAINS AND BY-PRODUCTS.				
Barley	89.1	8.7	65.6	1.6
Brewers' Grains, dry	91.8	15.7	36.3	5.1
Brewers' Grains, wet.....	24.3	3.9	9.3	1.4
Malt Sprouts	89.8	18.6	37.1	1.7
Buckwheat	87.4	7.7	49.2	1.8
Buckwheat Bran.....	89.5	7.4	30.4	1.9
Buckwheat Middlings	87.3	22.0	33.4	5.4
Corn.....	89.1	7.9	66.7	4.3
Corn and Cob—Meal.....	89.0	6.4	63.0	3.5
Corn Cob	89.3	0.4	52.5	0.3
Corn Bran	90.9	7.4	59.8	4.6
Atlas Gluten Meal	92.0	24.6	38.8	11.5
Gluten Meal.....	88.0	32.1	41.2	2.5
Germ Oil Meal	90.0	20.2	44.5	8.8
Gluten Feed	90.0	23.3	50.7	2.7
Hominy Chop	88.9	7.5	55.2	6.8
Starch Feed, wet.....	34.6	5.5	21.7	2.3
Cotton Seed	89.7	12.5	30.0	17.3
Cotton Seed Meal	91.8	37.2	16.9	8.4
Cotton Seed Hulls	88.9	0.3	33.1	1.7
Cocoanut Meal	89.7	15.6	38.3	10.5
Cow Peas	85.2	18.3	54.2	1.1
Flax Seed	90.8	20.6	17.1	29.0
Oil Meal, old process.....	90.8	29.3	32.7	7.0
Oil Meal, new process.....	89.9	28.2	40.1	2.8

NAME OF FEED:	DRY MATTER IN 100 POUNDS.	DIGESTIBLE NUTRIENTS IN 100 POUNDS.		
		Protein.	Carbo- hydrates.	Ether Extract. (Crude Fat.)
GRAIN AND BY-PRODUCTS.				
	Lbs.	Lbs.	Lbs.	Lbs.
Cleveland Oil Meal	89.6	32.1	25.1	2.6
Kaffir Corn	84.8	7.8	57.1	2.7
Millet	86.0	8.9	45.0	3.2
Oats	89.0	9.2	47.3	4.2
Oat Feed or Shorts	92.3	12.5	46.9	2.8
Oat Dust	93.5	8.9	38.4	5.1
Peas	89.5	16.8	51.8	0.7
Quaker Dairy Feed	92.5	9.4	50.1	3.0
Rye	88.4	9.9	67.6	1.1
Rye Bran	88.4	11.5	50.3	2.0
Wheat	89.5	10.2	69.2	1.7
Wheat Bran	88.1	12.6	38.6	3.0
Wheat Middlings	87.9	12.8	53.0	3.4
Wheat Shorts	88.2	12.2	50.0	3.8

WEIGHT OF CONCENTRATED FEEDS.

Kind of Feed.	One Quart Equals	One Pound Equals
Cotton Seed Meal	1.4 pounds	0.71 quarts
Linseed Meal, old process ..	1.1 "	0.90 "
Gluten Meal	1.8 "	0.55 "
Gluten Feed	1.3 "	0.71 "
Germ Oil Meal	1.4 "	0.71 "
Brewers' Grains	0.6 "	1.70 "
Malt Sprouts	0.6 "	1.70 "
Wheat Bran	0.5 "	2.00 "
Wheat Middlings, standard..	0.8 "	1.25 "
Wheat Middlings, flour	1.2 "	0.83 "
Corn Kernels	1.7 "	0.60 "
Corn Meal	1.5 "	0.70 "
Corn and Cob Meal	1.4 "	0.67 "
Corn Bran	0.5 "	2.00 "
Oat Kernels	1.1 "	0.90 "
Oats (ground)	0.7 "	1.40 "
Wheat Kernels	1.9 "	0.53 "
H-O Dairy Feed	0.7 "	1.43 "
Quaker Dairy Feed	1.0 "	1.00 "
Victor Corn and Oat Feed...	0.7 "	1.43 "

SOILING CROP ADAPTED TO NORTHERN NEW ENGLAND STATES. (Lindsey.)

(For 10 cows' entire soiling.)

Kind.	Seeds Per Acre.	Time of Seeding.	Area.	Time of Cutting.
Rye.....	2 bu	Sept. 10-15	½ acre	May 20 - May 30
Wheat.....	2 bu	" 10-15	½ "	June 1 - June 15
Red clover....	20 lbs.....	Jul. 15-Aug. 1	½ "	June 15 - June 25
Grass and clover	½ bu. red top	} Sept.	} ¾ "	} June 15 - June 30
	1 pk. timothy			
Vetch and oats	10 lbs. red clo.	} April 20	} ½ "	} June 25 - July 10
	3 bu. oats....			
Peas and oats	50 lbs. vetch.	} " 30	} ½ "	} July 10 - July 20
	1½ bu. Can'da			
Barnyard millet	1½ bu. oats..	} April 20	} ½ "	} June 25 - July 10
	1 peck.....			
Soja bean (medium green)	1 "	" 30	½ "	July 10 - July 20
	18 quarts....	May 10	⅓ "	July 25 - Aug. 10
Corn.....	18 "	" 25	⅓ "	Aug. 10 - Aug. 20
	18 "	" 20	⅓ "	Aug. 25 - Sept. 10
Hungarian....	18 "	" 30	⅓ "	Sept. 10 - Sept. 20
	1 bu.....	July 15	½ "	Sept. 20 - Sept. 30
Barley and peas	1½ bu. peas .	} Aug. 5	} 1 "	} Oct. 1 - Oct. 20
	1½ bu. barley			

TIME OF PLANTING AND FEEDING SOILING CROPS. (Phelps.)

Kind of Fodder.	Amount of Seed Per Acre.	Approximate Time of Seeding.	Approximate Time of Feeding.
1. Rye fodder.....	2½ to 3 bu.	Sept. 1	May 10-20
2. Wheat fodder.....	2½ to 3 bu.	Sept. 5-10	May 20-June 5
3. Clover.....	20 lbs.	July 20-30	June 5-15
4. Grass (from grass lands).....	June 15-25
5. } Oats and peas	2 bu. each	{ April 10	June 25-July 10
		{ " 20	July 10-20
		{ " 30	July 20-Aug. 1
8. Hungarian.....	1½ bu.	June 1	Aug. 1-10
9. Clover rowen (from 3)	Aug. 10-20
10. Soja beans (from 3) ..	1 bushel	May 25	Aug. 20-Sept. 5
11. Cow peas.....	1 "	June 5-10	Sept. 5-20
12. Rowen grass (from grass lands).....	Sept. 20-30
13. Barley and peas.....	2 bu. each	Aug. 5-10	Oct. 1-30

The dates given in the table apply to Central Connecticut and regions under approximately similar conditions.

COST OF A POUND OF DIGESTIBLE DRY MATTER IN
DIFFERENT FEEDING STUFFS.

FEEDS.	Cost Per 100 Lbs.	Total Digestible Nutrients.	Cost Per Pound for Digestible Nutrients.
		Lbs.	Cents.
Corn meal.....	\$0.80	79.5	1.01
Cob meal78	71.3	1.09
Oats90	67.0	1.34
Provender85	72.3	1.18
Quaker dairy feed.....	.85	60.9	1.40
H-O dairy feed	1.00	63.7	1.57
Corn and oat feed.....	.85	70.4	1.21
Hominy chop90	88.8	1.01
Wheat bran85	57.9	1.47
Wheat middlings95	70.6	1.35
Mixed (wheat) feed90	64.8	1.39
Cottonseed meal.....	1.20	80.3	1.50
Linseed meal, old process	1.30	77.1	1.69
Linseed meal, new process	1.30	74.5	1.74
Flax meal	1.30	75.5	1.72
Chicago gluten meal.....	1.20	78.9	1.52
Cream gluten meal.....	1.20	81.1	1.48
King gluten meal	1.20	86.7	1.38
Buffalo gluten feed.....	1.00	80.1	1.25
Diamond gluten feed	1.00	82.3	1.22

READY REFERENCE TABLE OF CONTENTS. 211

IN VARYING WEIGHTS OF FEED IN POUNDS.

NOTE.—These tables save calculations of percentages, since the weights and contents being given in pounds, it is only necessary to find the kind and desired amount of a certain feed, and the table gives the exact food contents in pounds, as in the first table, 15 lbs. of Green Oat Fodder contains 5.7 lbs. of dry matter, 0.35 lbs. of protein and 3.1 lbs. carbohydrates.

POUNDS OF FODDER.	Pasture Grass, 1:4.8			Timothy Grass, 1:14.3			Ky. Blue Grass, 1:9.2		
	Total Dry Matter.	Protein.	Carbohydrates, etc.	Total Dry Matter.	Protein.	Carbohydrates, etc.	Total Dry Matter.	Protein.	Carbohydrates, etc.
Grasses.	Pasture Grass, 1:4.8			Timothy Grass, 1:14.3			Ky. Blue Grass, 1:9.2		
2½.....	0.5	0.06	0.3	1.0	0.04	0.5	0.9	0.05	0.5
5.....	1.0	0.12	0.6	1.9	0.08	1.1	1.8	0.10	0.9
10.....	2.0	0.23	1.1	3.8	0.15	2.1	3.5	0.20	1.8
15.....	3.0	0.35	1.7	5.8	0.23	3.2	5.2	0.30	2.7
20.....	4.0	0.46	2.2	7.7	0.30	4.3	7.0	0.40	3.7
25.....	5.0	0.58	2.8	9.6	0.38	5.4	8.7	0.50	4.7
30.....	6.0	0.69	3.3	11.5	0.45	6.4	10.5	0.60	5.5
35.....	7.0	0.81	3.9	13.4	0.53	7.5	12.2	0.70	6.4
40.....	8.0	0.92	4.4	15.4	0.60	14.0	14.0	0.80	7.3
Green Fodders.	Green Fodder Corn, 1:11.7			Green Oat Fodder, 1:8.7			Green Rye Fodder, 1:7.2		
2½.....	0.5	0.03	0.3	0.9	0.06	0.5	0.6	0.05	0.4
5.....	1.0	0.06	0.6	1.9	0.12	1.0	1.2	0.11	0.7
10.....	2.1	0.11	1.3	3.8	0.24	2.1	2.3	0.21	1.5
15.....	3.1	0.17	1.9	5.7	0.36	3.1	3.5	0.32	2.3
20.....	4.1	0.22	2.6	7.6	0.48	4.2	4.7	0.42	3.0
25.....	5.2	0.28	3.2	9.5	0.60	5.2	5.9	0.52	3.8
30.....	6.2	0.33	3.9	11.3	0.72	6.2	7.0	0.63	4.5
35.....	7.2	0.39	4.5	13.2	0.84	7.3	8.2	0.74	5.3
40.....	8.3	0.44	5.2	15.1	0.96	8.3	9.4	0.84	6.0
Green Fodders.	Oats and Peas, 1:4.2			Barley and Peas, 1:3.2			Red Clover (green), 1:5.7		
2½.....	0.5	0.07	0.3	0.5	0.07	0.2	0.7	0.07	0.4
5.....	1.1	0.14	0.5	1.0	0.14	0.4	1.5	0.15	0.8
10.....	2.1	0.27	1.1	2.1	0.28	0.9	2.9	0.29	1.6
15.....	3.2	0.41	1.7	3.1	0.42	1.4	4.4	0.44	2.5
20.....	4.3	0.54	2.3	4.1	0.56	1.8	5.9	0.58	3.3
25.....	5.3	0.68	2.9	5.2	0.70	2.3	7.3	0.73	4.1
30.....	6.4	0.81	3.4	6.2	0.84	2.7	8.8	0.87	4.9
35.....	7.5	0.95	4.0	7.2	0.96	3.2	10.2	1.02	5.7
40.....	8.5	1.08	4.6	8.2	1.12	3.6	11.7	1.16	6.6
Green Fodders.	Corn Silage, 1:14.3			Corn Stover Silage, 1:16.6			Clover Silage, 1:4.7		
2½.....	0.7	0.03	0.4	0.5	0.02	0.3	0.7	0.07	0.3
5.....	1.3	0.06	0.8	1.0	0.03	0.5	1.4	0.14	0.6
10.....	2.6	0.12	1.8	1.9	0.06	1.0	2.8	0.27	1.3
15.....	3.9	0.18	2.7	2.9	0.09	1.5	4.2	0.41	1.9
20.....	5.3	0.24	3.6	3.9	0.12	2.0	5.6	0.54	2.6
25.....	6.6	0.30	4.5	4.8	0.15	2.5	7.0	0.68	3.2
30.....	7.9	0.36	5.3	5.8	0.18	3.0	8.4	0.81	3.9
35.....	9.2	0.42	6.2	6.8	0.21	3.5	9.8	0.95	4.5
40.....	10.5	0.48	7.1	7.7	0.24	4.0	11.2	1.08	5.1

212 **READY REFERENCE TABLE OF CONTENTS.**

VARYING WEIGHTS OF FEED IN POUNDS.—CONTINUED.

POUNDS OF FODDER.	Potatoes, 1:7.3			Sugar Beets, 1:6.8			Carrots, 1:9.6		
	Total Dry Matter.	Protein.	Carbohydrates, etc.	Total Dry Matter.	Protein.	Carbohydrates, etc.	Total Dry Matter.	Protein.	Carbohydrates, etc.
Roots	Potatoes, 1:7.3			Sugar Beets, 1:6.8			Carrots, 1:9.6		
2½.....	0.5	0.02	0.4	0.3	0.04	0.3	0.3	0.03	0.2
5.....	1.1	0.05	0.8	0.7	0.08	0.5	0.5	0.05	0.5
10.....	2.1	0.09	1.6	1.4	0.16	1.1	1.1	0.10	1.0
15.....	3.2	0.14	2.3	2.0	0.24	1.7	1.6	0.15	1.4
20.....	4.2	0.18	3.1	2.7	0.32	2.2	2.3	0.20	1.9
25.....	5.3	0.23	3.9	3.4	0.40	2.7	2.9	0.25	2.4
30.....	6.3	0.27	4.7	4.1	0.48	3.3	3.4	0.30	2.9
35.....	7.4	0.32	5.4	4.7	0.56	3.8	4.0	0.35	3.4
40.....	8.4	0.36	6.2	5.4	0.64	4.4	4.6	0.40	3.8
Roots	Mangel Wurtzels, 1:4.9			Rutabagas, 1:8.6			Turnips, 1:7.7		
2½.....	0.2	0.03	0.1	0.3	0.03	0.2	0.2	0.03	0.2
5.....	0.4	0.06	0.3	0.5	0.05	0.4	0.5	0.05	0.4
10.....	0.9	0.11	0.5	1.1	0.10	0.9	1.0	0.10	0.8
15.....	1.4	0.17	0.8	1.6	0.15	1.3	1.4	0.15	1.2
20.....	1.8	0.22	1.1	2.3	0.20	1.7	1.9	0.20	1.5
25.....	2.3	0.28	1.4	2.9	0.25	2.2	2.4	0.25	1.9
30.....	2.7	0.33	1.6	3.4	0.30	2.6	2.9	0.30	2.3
35.....	3.2	0.39	1.9	4.0	0.35	3.0	3.3	0.35	2.7
40.....	3.6	0.44	2.2	4.6	1.40	3.4	3.8	0.40	3.1
Milk	Skim Milk, 1:2.0			Buttermilk, 1:1.7			Whey, 1:8.7		
2½.....	0.2	0.07	0.1	0.2	0.10	0.2	0.2	0.02	0.1
5.....	0.5	0.15	0.3	0.5	0.19	0.3	0.3	0.03	0.3
10.....	0.9	0.29	0.6	1.0	0.38	0.6	0.6	0.06	0.5
15.....	1.4	0.44	0.9	1.5	0.57	1.0	0.9	0.09	0.8
20.....	1.9	0.58	1.2	2.0	0.76	1.3	1.2	0.12	1.0
25.....	2.4	0.73	1.6	2.5	0.95	1.6	1.5	0.15	1.3
30.....	2.8	0.87	1.8	3.0	1.14	1.9	1.9	0.18	1.6
35.....	3.2	1.02	2.1	3.5	1.33	2.2	2.2	0.21	1.8
40.....	3.7	1.16	2.4	4.0	1.52	2.6	2.5	0.24	2.1
Hays	Mixed Hay, 1:10.0			Timothy Hay, 1:16.5			Ky. Blue Grass Hay, 1:10.6		
2½.....	2.1	0.11	1.1	.22	0.07	1.2	1.9	0.09	1.0
5.....	4.2	0.22	2.2	.43	0.15	2.3	3.7	0.19	2.0
7½.....	6.4	0.33	3.3	.65	0.21	3.5	5.6	0.28	3.0
10.....	8.5	0.44	4.4	.87	0.28	4.6	7.4	0.37	3.9
12½.....	10.6	0.55	5.5	1.09	0.35	5.8	9.2	0.46	4.9
15.....	12.7	0.66	6.6	1.30	0.42	6.9	11.1	0.56	5.9
17½.....	14.8	0.77	7.7	1.52	0.49	8.1	13.0	0.65	6.9
20.....	16.9	0.88	8.8	1.74	0.56	9.2	14.8	0.74	7.9
25.....	21.2	1.10	11.0	2.17	0.70	11.6	18.5	0.93	9.9

READY REFERENCE TABLE OF CONTENTS. 213

VARYING WEIGHTS OF FEED IN POUNDS—CONTINUED.

POUNDS OF FODDER.	Oat Hay, 1:9.9			Oat and Pea Hay, 1:4.1			Hungarian, 1:10.0		
	Total Dry Matter.	Protein.	Carbohy- drates, etc.	Total Dry Matter.	Protein.	Carbohy- drates, etc.	Total Dry Matter.	Protein.	Carbohy- drates, etc.
Hays	Oat Hay, 1:9.9			Oat and Pea Hay, 1:4.1			Hungarian, 1:10.0		
2½	2.3	0.10	1.0	2.2	0.28	1.2	2.1	0.12	1.2
5	4.6	0.21	2.0	4.4	0.56	2.3	4.2	0.25	2.4
7½	6.8	0.31	3.0	6.6	0.84	3.5	6.3	0.37	3.5
10	9.1	0.41	4.0	8.9	1.12	4.6	8.4	0.49	4.9
12½	11.4	0.51	5.1	11.1	1.40	5.8	10.4	0.62	6.2
15	13.7	0.62	6.1	13.3	1.68	6.9	12.5	0.74	7.4
17½	16.0	0.72	7.1	15.5	1.96	8.1	14.6	0.86	8.6
20	18.2	0.82	8.1	17.7	2.24	9.2	16.7	0.98	9.8
25	22.8	1.03	10.2	22.1	2.80	11.6	20.8	1.23	12.3
Hays, etc.	Red Clover Hay, 1:5.9			Alsike Clover Hay, 1:5.5			Oat Straw, 1:38.3		
2½	2.1	0.18	1.0	2.3	0.21	1.2	2.3	0.03	1.2
5	4.2	0.36	2.1	4.5	0.42	2.3	4.6	0.06	2.3
7½	6.4	0.53	3.2	6.8	0.63	3.5	6.8	0.09	3.5
10	8.5	0.71	4.2	9.0	0.84	4.6	9.1	0.12	4.6
12½	10.6	0.89	5.2	11.3	1.05	5.8	11.4	0.15	5.8
15	12.7	1.07	6.3	13.5	1.26	6.9	13.9	0.18	6.9
17½	14.8	1.24	7.3	15.8	1.47	8.1	16.0	0.21	8.1
20	16.9	1.42	8.3	18.1	1.68	9.2	18.2	0.24	9.2
25	21.2	1.78	10.5	22.6	2.10	11.6	22.7	0.30	11.5
Dry Fodder	Corn Fodder, 1:14.3			Corn Stover, 1:23.6			Wheat Straw, 1:95.0		
2½	1.4	0.06	0.9	1.5	0.04	0.8	2.3	0.01	0.9
5	2.9	0.13	1.8	3.0	0.07	1.7	4.5	0.02	1.9
7½	4.3	0.19	2.7	4.5	0.11	2.5	6.8	0.03	2.8
10	5.8	0.25	3.6	6.0	0.14	3.3	9.0	0.04	3.7
12¼	7.2	0.32	4.5	7.5	0.18	4.1	11.3	0.05	4.6
15	8.7	0.38	5.4	9.0	0.21	5.0	13.5	0.06	5.6
17½	10.1	0.44	6.2	10.5	0.25	5.8	15.8	0.07	6.5
20	11.6	0.50	7.1	12.0	0.28	6.6	18.1	0.08	7.4
25	14.5	0.63	8.9	15.0	0.35	8.3	22.6	0.10	9.3
Grains	Corn Meal, 1:11.3			Corn & Cob Meal, 1:13.9			Oats, 1:6.2		
¼	0.2	0.02	0.2	0.2	0.01	0.2	0.2	0.02	0.1
½	0.4	0.03	0.4	0.4	0.02	0.3	0.4	0.05	0.3
1	0.9	0.06	0.7	0.9	0.05	0.7	0.9	0.09	0.6
2	1.7	0.13	1.4	1.7	0.10	1.3	1.8	0.18	1.1
3	2.6	0.19	2.1	2.6	0.14	2.0	2.7	0.28	1.7
4	3.4	0.25	2.9	3.4	0.19	2.7	3.6	0.37	2.3
5	4.3	0.32	3.6	4.3	0.24	3.4	4.5	0.46	2.8
7½	6.4	0.48	5.4	6.4	0.36	5.1	6.7	0.69	4.3
10	8.5	0.63	7.1	8.5	0.48	6.7	8.9	0.92	5.7

214 READY REFERENCE TABLE OF CONTENTS.

VARYING WEIGHTS OF FEED IN POUNDS—CONTINUED.

POUNDS OF FODDER.	Barley, 1:8.9			Barley Screenings, 1:7.7			Wheat Bran, 1:3.8		
	Total Dry Matter.	Protein.	Carbohydrates, etc.	Total Dry Matter.	Protein.	Carbohydrates, etc.	Total Dry Matter.	Protein.	Carbohydrates, etc.
By Products.	Barley, 1:8.9			Barley Screenings, 1:7.7			Wheat Bran, 1:3.8		
1/4.....	0.2	0.02	0.2	0.2	0.02	0.2	0.2	0.03	0.1
1/2.....	0.4	0.04	0.3	0.4	0.04	0.3	0.4	0.06	0.2
1.....	0.9	0.09	0.7	0.9	0.09	0.7	0.9	0.12	0.5
2.....	1.8	0.17	1.4	1.8	0.17	1.3	1.8	0.24	1.0
3.....	2.7	0.26	2.1	2.6	0.26	2.0	2.6	0.36	1.4
4.....	3.6	0.35	2.8	3.5	0.34	2.7	3.5	0.48	1.8
5.....	4.5	0.44	3.5	4.4	0.43	3.3	4.4	0.60	2.3
7 1/2.....	6.7	0.65	5.2	6.6	0.65	5.0	6.6	0.90	3.4
10.....	8.9	0.87	6.9	8.8	0.86	6.6	8.8	1.20	4.6
By Products.	Wheat Middlings, 1:4.6			Wheat Screenings, 1:5.2			Red-dog Flour, 1:3.3		
1/4.....	0.2	0.03	0.1	0.2	0.02	0.1	0.2	0.04	0.1
1/2.....	0.4	0.06	0.3	0.4	0.05	0.2	0.5	0.09	0.3
1.....	0.9	0.13	0.6	0.9	0.10	0.5	0.9	0.18	0.6
2.....	1.8	0.25	1.2	1.8	0.20	1.0	1.8	0.36	1.2
3.....	2.6	0.38	1.7	2.7	0.29	1.5	2.7	0.53	1.7
4.....	3.5	0.50	2.3	3.5	0.39	2.0	3.6	0.71	2.3
5.....	4.4	0.63	2.9	4.4	0.49	2.5	4.6	0.89	2.9
7 1/2.....	6.6	0.94	4.4	6.6	0.74	3.8	6.8	1.34	4.4
10.....	8.8	1.25	5.8	8.8	0.98	5.1	9.1	1.78	5.8
By Products.	Rye, 1:7.8			Rye Bran, 1:5.1			Cottonseed Meal, 1:1.0		
1/4.....	0.2	0.02	0.2	0.2	0.03	0.2	0.2	0.10	0.1
1/2.....	0.4	0.04	0.3	0.4	0.06	0.3	0.5	0.20	0.2
1.....	0.9	0.09	0.7	0.9	0.12	0.6	0.9	0.40	0.4
2.....	1.8	0.18	1.4	1.8	0.25	1.3	1.8	0.80	0.8
3.....	2.7	0.27	2.1	2.7	0.37	1.9	2.9	1.20	1.2
4.....	3.5	0.36	2.8	3.5	0.49	2.5	3.7	1.60	1.6
5.....	4.4	0.46	3.5	4.4	0.62	3.1	4.6	2.00	2.0
7 1/2.....	6.6	0.67	5.2	6.6	0.92	4.6	6.9	3.00	3.0
10.....	8.8	0.89	6.9	8.8	1.23	6.3	9.2	4.00	4.0
By Products.	Cottonseed Hulls, —			Linseed Meal o. p., 1:1.5			Linseed Meal n. p., 1:1.3		
1/4.....	0.2	0.1	0.2	0.08	0.1	0.2	0.08	0.1
1/2.....	0.4	0.2	0.5	0.15	0.2	0.4	0.16	0.2
1.....	0.9	0.4	0.9	0.31	0.5	0.9	0.32	0.4
2.....	1.8	0.7	1.8	0.62	1.0	1.8	0.65	0.8
3.....	2.7	1.1	2.7	0.92	1.4	2.7	0.97	1.3
4.....	3.6	1.5	3.6	1.23	1.8	3.6	1.30	1.7
5.....	4.5	1.8	4.9	1.54	2.3	4.5	1.62	2.1
7 1/2.....	6.7	2.7	6.8	2.31	3.4	6.7	2.43	3.2
10.....	8.9	3.7	9.0	3.08	4.6	8.9	3.24	4.2

READY REFERENCE TABLE OF CONTENTS. 215

VARYING WEIGHTS OF FEED IN POUNDS—CONTINUED.

POUNDS OF FODDER	Flax Meal, 1:1.4			Gluten Meal (Chi.) 1:1.5			Gluten Meal (Cr'm.) 1:1.7		
	Total Dry Matter.	Protein.	Carbohy- drates, etc.	Total Dry Matter.	Protein	Carbohy- drates, etc.	Total Dry Matter.	Protein.	Carbohy- drates, etc.
By Products	Flax Meal, 1:1.4			Gluten Meal (Chi.) 1:1.5			Gluten Meal (Cr'm.) 1:1.7		
1/4.....	0.2	0.08	0.1	0.2	0.08	0.1	0.2	0.07	0.1
1/2.....	0.4	0.16	0.2	0.4	0.16	0.2	0.4	0.15	0.2
1.....	0.9	0.32	0.4	0.9	0.32	0.5	0.9	0.30	0.5
2.....	1.9	0.64	0.9	1.8	0.64	0.9	1.8	0.59	1.0
3.....	2.7	0.96	1.3	2.6	0.96	1.4	2.7	0.89	1.5
4.....	3.6	1.28	1.7	3.5	1.28	1.9	3.6	1.19	2.1
5.....	4.5	1.60	2.2	4.4	1.60	2.3	4.5	1.49	2.6
7 1/2.....	6.7	2.40	3.3	6.6	2.40	3.5	6.7	2.23	3.9
10.....	8.9	3.21	4.3	8.8	3.21	4.7	9.0	2.97	5.1
By Products	GlutenFd. (Buffalo) 1:2.4			Hominy Chop, 1:9.2			Dried Brewers' G'r, 1:3.0		
1/4.....	0.2	0.06	0.1	0.2	0.02	0.2	0.2	0.04	0.1
1/2.....	0.4	0.12	0.3	0.5	0.04	0.4	0.5	0.08	0.3
1.....	0.9	0.23	0.6	0.9	0.09	0.8	0.9	0.16	0.5
2.....	1.8	0.47	1.1	1.8	0.17	1.6	1.8	0.31	0.9
3.....	2.7	0.70	1.7	2.8	0.26	2.4	2.8	0.47	1.4
4.....	3.6	0.93	2.3	3.7	0.35	3.2	3.7	0.63	1.9
5.....	4.5	1.17	2.8	4.6	0.44	4.0	4.6	0.79	2.4
7 1/2.....	6.8	1.74	4.3	6.9	0.65	6.0	6.9	1.18	3.5
10.....	9.0	2.33	5.9	9.2	0.87	8.0	9.2	1.57	4.7
By Products	Atlas Gluten Meal, 1:2.6			Malt Sprouts, 1:2.2			Pea Meal, 1:3.2		
1/4.....	0.2	0.06	0.2	0.2	0.05	0.1	0.2	0.04	0.1
1/2.....	0.5	0.12	0.3	0.4	0.09	0.2	0.4	0.08	0.3
1.....	0.9	0.25	0.6	0.9	0.19	0.4	0.9	0.17	0.5
2.....	1.8	0.49	1.3	1.8	0.37	0.8	1.8	0.33	1.1
3.....	2.8	0.74	1.9	2.7	0.56	1.2	2.7	0.50	1.6
4.....	3.7	0.98	2.6	3.6	0.74	1.6	3.6	0.67	2.1
5.....	4.6	1.23	3.2	4.5	0.93	2.0	4.5	0.84	2.7
7 1/2.....	6.9	1.85	4.9	6.7	1.40	3.0	6.7	1.26	4.0
10.....	9.2	2.46	6.5	9.0	1.86	4.0	9.0	1.68	5.3

CONCLUSION.

In conclusion we desire to state that the object of this book is to place before the farmer, dairyman and stockman such information as will be valuable and practical, in as concise and plain a manner as possible, and to make a plea in behalf of the silo as an improver of the financial condition of the farmer. That the silo is a prime factor in modern agriculture is no longer a matter of doubt. The silo is not the sum total in itself, but as an adjunct, and, in the case of dairying, a necessary adjunct to successful and profitable methods, its value is difficult to overestimate.

One of the greatest values of the silo is that as an innovation it becomes a stepping-stone to better methods in general; it stimulates its owner and spurs him on to see just how good and far-reaching results he can obtain from his revised system of management. It invites a little honest effort, and coupled with this it never fails. It enables its owner not only to do what he has been unable to do before, but things he has done without its help the silo enables him to do at less cost than before. The solution of the problem of cost of manufacture is necessary to every successful producer, and as the proposition is constantly changing, the solutions of our forefathers, or even of a generation ago, no longer avail. The silo is not an enticing speculation by means of which something can be gotten out of nothing, but a sound business proposition, and has come to stay. The voices of thousands of our best farmers and dairymen sing its praises, because it has brought dollars into their pockets, and increased enjoyment to them in their occupations and their homes.

Have you cows? Do you feed stock? Do you not need a silo? Is it not worthy of your best thought and consideration? You owe it to yourself to make the most you can out of the opportunities before you. DO IT NOW!

GLOSSARY.

Ad libitum. At pleasure; in case of feeding farm animals, all they will eat of a particular feeding stuff.

Albuminoids. A group of substances of the highest importance in feeding farm animals, as they furnish the material from which flesh, blood, skin, wool, casein of milk, and other animal products are manufactured. Another name for albuminoids is flesh-forming substances or protein.

Ash. The portion of a feeding stuff which remains when it is burned, the incombustible part of foods. The ash of feeding stuffs goes to make the skeleton of young animals, and in the case of milch cows a portion thereof goes into the milk or milk ash.

Bacteria. Microscopic vegetable organisms usually in the form of a jointed rod-like filament, and found in putrefying organic infusions. They are widely diffused in nature, and multiply with marvelous rapidity. Certain species are active agents in fermentation, while others appear to be the cause of certain infectious diseases.

Balanced ration. A combination of feeding stuffs, containing the various nutrients in such proportions and amounts as will nurture the animals for twenty-four hours, with the least waste of nutrients.

By-Products. A secondary product of an industry; cottonseed meal is a by-product of the cotton oil industry; skim milk and butter milk are by-products of butter making.

Carbohydrates. A group of nutrients rich in carbon and containing oxygen and hydrogen in the proportion in which they form water. The most important carbohydrates found in feeding stuffs are starch, gums and crude fiber (cellulose.)

Carbon. A chemical element, which, with the elements of water makes up the larger part of the dry matter of plants and animals.

Carbonic acid. A poisonous gas arising from the combustion of coal or wood. It is formed in all kinds of fermentations and therefore occurs in the siloing of fodders.

Cellulose. See Crude fiber.

Crude fiber. The frame work forming the walls of cells of plants. It is composed of cellulose and lignin, the latter being the woody portion of plants and wholly indigestible.

Digestible matter. The portion of feeding stuffs which is digested by animals, i. e., brought in solution or semi-

solution by the digestive fluids, so that it may serve as nourishment for the animal and furnish material for the production of meat, milk, wool, eggs, etc.

Dry matter. The portion of a feeding stuff remaining after the water contained therein has been removed.

Ensilage. An obsolete word for Silage. Used as a verb, likewise obsolete, for to silo; to ensile also sometimes incorrectly used for the purpose of placing green fodders into a silo.

Enzymes. An unorganized or chemical compound of vegetable or animal origin, that causes fermentation, as, pepsin, or rennet.

Ether extract. The portion of a feeding stuff dissolved by ether; mainly fat or oil in case of concentrated feeding stuffs; in coarse fodders, fat, mixed with a number of substances of uncertain feeding value, like wax, chlorophyll (the green coloring matter of plants), etc.

Fat. See Ether extract.

Feeding standard. A numerical expression of the amount of various digestible substances in a combination of feeding stuffs best adapted to give good results as regards production of animal products, like beef, pork, milk, etc.

Indian corn. Zea Mays, the great American cereal and fodder-producing plant.

Hydrogen. A chemical element, a gas. Combined with oxygen it forms water, with oxygen and carbon it forms carbohydrates and fat; with oxygen, carbon and nitrogen (with small amounts of sulphur and phosphorus) it forms the complex organic nitrogenous substances known as protein albuminoid substances.

Legumes. Plants bearing seeds in pods and capable of fixing the gaseous nitrogen of the air, so that it becomes of value to the farmer and will supply nitrogenous food substances to farm animals. Examples, the different kinds of clover, peas, beans, vetches, etc. Of the highest importance agriculturally, as soil renovators, and in supplying farm-grown protein foods.

Nitrogen. A chemical element, making up four-fifths of the air. The central element of protein. See under Hydrogen.

Nitrogen-free extract. The portion of a feeding stuff remaining when water, fat, protein, crude fiber, and ash are deducted. It includes starch, sugar, pentosans, and other substances. It is so called because it does not contain any nitrogen.

Nitrogenous substances. Substances containing nitrogen (which see).

Nutrient. A food constituent or group of food constituents capable of nourishing animals.

Nutritive ratio. The proportion of digestible protein to the sum of digestible carbohydrates and fat in a ration, the per cent. of fat being multiplied by $2\frac{1}{4}$, and added to the per cent. of carbohydrates (crude fiber plus nitrogen-free extract).

Organic matter. The portion of the dry matter which is destroyed on combustion (dry matter minus ash).

Oxygen. A chemical element found in a free state in the air, of which it makes up about one-fifth, and in combination of hydrogen in water; oxygen is also a rarely-lacking component of organic substances. See **Carbohydrates and Hydrogen.**

Protein. A general name for complex organic compounds mainly made up from the elements carbon, hydrogen, oxygen, and nitrogen. Crude protein includes all organic nitrogen compounds, while true protein or albuminoids (which see) only includes such nitrogenous substances in feeding stuffs as are capable of forming muscle and other tissue in the animal body.

Ration. The amount of food that an animal eats during twenty-four hours.

Roughage. The coarse portion of a ration, including such feeding stuffs as hay, silage, straw, corn fodder, roots, etc. Concentrated feeding stuffs are sometimes called **grain-feeds** or **concentrates**, in contradistinction to roughage.

Silage. The succulent feed taken out of a silo. Formerly called ensilage.

Silo. An air-tight structure used for the preservation of green, coarse fodders in a succulent condition. As verb, to place green fodders in a silo.

Soiling. The system of feeding farm animals in a barn or enclosure with fresh grass or green fodders, as rye, corn, oats, Hungarian grass, etc.

Starch. One of the most common carbohydrates in feeding stuffs insoluble in water, but readily digested and changed in sugar in the process of digestion.

Succulent feeds. Feeding stuffs containing considerable water, like green fodder, silage roots and pasture.

Summer silage. Silage intended to be fed out during the summer and early fall to help out short pastures.

Summer silo. A Silo used for the making of **summer silage.**

INDEX

	PAGE
Advantages of the silo.....	11, 182
Alfalfa silage	142
Analyses of feeding stuffs.....	205
Animal body, composition of the.....	190
Ash	192
Average composition of silage crops.....	204
Beet-pulp silage	146
Beets, cost of, per acre.....	184
Beef cattle, silage for.....	173
Blower elevators	159
Brick silos	105
Capacity of round silos.....	53
Carbonic-acid poisoning in silos, danger from.....	160
Cement block silos, how made, reinforcing, etc. of....	127
Cement lining, how to maintain.....	129
Certified milk, silage in production of.....	169
Chemical composition of silage.....	204
Chute for a round wooden silo.....	102
Circles, circumferences, and areas of.....	101
Clover silage	140, 163
Clover silage, cost of.....	141
Clover, time of cutting for the silo.....	141, 142
Clover, yield per acre of.....	142
Concrete silos	121, 126
Concrete silos, forms used for making.....	131
Conserving soil fertility with silage system.....	42
Corn, cutting of, in the field.....	149
Corn land, preparation of.....	133
Corn, methods of planting.....	139
Corn silage vs. fodder corn.....	186
Corn silage vs. hay.....	184
Corn silage vs. roots.....	182
Corn, siloing of, "ears and all".....	152
Corn, see also Indian corn and Fodder corn.	
Corners of square silos, methods of excluding air from	107
Cost of beets per acre.....	184
Cost of a pound of digestible dry matter in different feeding stuffs	211
Conclusion	216
Cost of corn silage	186
Cost of silos	112, 115
Covering silage	161
Cow-pea silage	143
Comparative losses in dry curing.....	15

	PAGE
Corn, time of cutting for silo.....	136
Composition of the animal body.....	190
Composition of the silage crops.....	204
Composition of feeding stuffs.....	191
Crude fiber.....	193
Cutter and power, size of.....	155, 157
Definition of terms used.....	217
Description of "Ohio" silage cutters.....	156, 228
Digestibility of foods.....	194
Doors for silos.....	68, 95
Drought, silo in times of.....	25
Ears and all, siloing of corn.....	152
Economy of storage.....	19
Elevators, pneumatic.....	159, 160
Ensilage, see Silage .	
Estimating of materials for silos.....	115
Feeders' guide, etc.....	190
Feeding stuffs, composition of.....	191
Feeding standards.....	196-199
Feeding of silage.....	167
Field-curing of fodder corn, losses in.....	11, 14
Filling of silo.....	20, 149, 155
Food from thistles.....	21
Food ingredients, increase in.....	138
Freezing of silage.....	165
Grain mixtures for dairy cows.....	200
Guide, a feeders'.....	192
Hauling corn from field, rack or sled for.....	151
Hills or drills, planting of corn in.....	139
History of the silo.....	7
Horizontal girts, silos with.....	109
Horses, silage for.....	174
How to feed silage.....	167
How to figure out rations.....	200
Indian corn, soil adapted for.....	133
Indian corn, methods of planting.....	139
Indian corn.....	133
Indian corn, chemical changes in.....	137
Indian corn, increase in food ingredients from tasseling to ripeness.....	138
Indian corn, varieties of, to be planted for the silo...	134
Indian corn, see also Corn and Fodder Corn .	
Ingleside farms, silos.....	158
Introduction.....	9
Lining for silos.....	70, 75
Losses in dry curing.....	11, 14
Losses in the siloing process.....	15

	PAGE
Losses in siloing Alfalfa.....	17
Low wagons for hauling corn.....	151
Lucerne, see Alfalfa.	
Materials for the silo.....	89
Metal bucket, chain elevators.....	157
Milch cows, silage rations for.....	171
Milch cows, silage for.....	167
Mineral matter	190
Modification of "Wisconsin" silo.....	76
Miscellaneous silage crops.....	146-148
New Jersey Experiment Station silo.....	158
Nitrogen-free extract	193
No danger of rain	19
Number of staves required for stave silos.....	100
Nutritive Ratio	197
Octagonal silos	108
Opinions of recognized leaders.....	188
"Ohio" silage cutters, description of.....	155, 160
Painting the silo lining.....	75
Plastered round wooden silos.....	77
Planting corn, methods of	139
Planting corn, thickness of	139
Pneumatic elevators	159
"Poultrymen's silos"	182
Poultry, silage for.....	181
Preparation of corn land.....	133
Preservation of silos.....	118, 120
Protein	193
Rack, low-down, for hauling corn.....	151
Rations, how to figure out.....	200
Rations, silage, for dairy cows.....	171
Ready reference tables.....	211, 215
Relative value of feeding stuffs.....	195
Reinforced concrete silo construction.....	125
Roof for the silo.....	73, 88, 96, 97
Round silos	53
Sheep, silage for.....	176
Shrinking of silage-fed cattle.....	38
Silage, alfalfa	142
Silage and soil fertility	42
Silage cart	168
Silage, chemical composition of.....	204
Silage, clover	140
Silage, cost of	141
Silage crops	188
Silage, feeding of	167
Silage for horses	174

	PAGE
Silage for milch cows	167, 171
Silage for poultry	181
Silage for sheep	176
Silage for beef cattle.....	173
Silage for swine	180
Silage-fed beef cattle in the South.....	37
Silage, freezing of	165
Silage good for stockers.....	40
Silage, how to feed	167
Silage, quantities of, required for different herds.....	54
Silage rations for milch cows.....	171
Silage, use of in beef production.....	28
Silage, steaming of	166
Silo, summer	23
Silos, acreage to fill	54
Silos, how to build	48
Silos, general requirements for.....	48
Silos, on the form of.....	54
Silos, the filling process	153
Silos, time of filling	149
Silos, roof for	103
Silos, round all-stone	103
Silos, round wooden	53
Silos, concrete	121-126
Silos, cement block	127
Silos, chute for	103
Silos, cost of	76, 77, 81, 96, 98, 112, 115
Silos, location of	58
Silos, specifications for.....	60, 76, 81, 86, 108
Silos, square, methods of excluding air from corners of	107
Silos, stone	105
Silos, value in intensive farming.....	21
Silos, ventilation of	24
Silos, with horizontal girts	109
Silos, foundation of	60, 61, 63, 65, 86, 109
Size of silo required.....	51
Silos, brick lined	81
Silos, all brick	105
Silos, in the barn	106
Silos, octagonal	108
Size of cutter and power required	155
Sorghum silage	145
Southern and Northern varieties of corn, comparative yield of	135
Soil fertility maintained with silage.....	42
Soiling crops, table of	209
Soiling crops, time of planting and feeding.....	209

	PAGE
Soja Beans	145
Specifications for a stave silo.....	86
Stave silos	83, 98
Stave silos, calculation of staves required for.....	101
Stave silos, roof of	88
Stave silos, specifications for.....	86
Staves, calculation of number required.....	101
Steamed silage	166
Steers, silage for	173
Stockers, silage good for.....	40
Stone silos	105
Succulence	18
Summer silo, advantages of.....	23
Summary results	40
Swine, silage for	180
Thickness of planting corn.....	139
Time of filling the silo	20, 149
Time of cutting corn for the silo.....	136
Use of silage in beef production.....	28
Value in intensive farming.....	21
Varieties of corn to be planted for the silo.....	134
Waste of roughness.....	38
Water, use of in filling silos	162
Weight of concentrated feeds.....	208
Wisconsin Experiment Station silos, description of 80,	82
Yields of clover per acre.....	140

15 Years' Experience with the Silo

By F. L. Allen.

MAPLE CREEK FARM

Trumbull Co., Ohio.

The Silver Manufacturing Co., Salem, Ohio.

Gentlemen:—Complying with your request I submit the following as embracing my experience of 15 years with the silo, and in feeding silage for milk and beef:

Economy of the Silo.

The silo cannot be looked upon as the only essential element of success in farm practice, yet there are many distinct advantages to be gained from its use. In the first place it enables one to use the entire corn crop. The analysis of the corn plant shows that nearly one-half its food value is in the stalk and leaves after the ear has been removed. It also shows that there is the most digestible matter in the crop just at its maturity, before it dries and hardens. By the usual methods of handling the crop, a large part—frequently all—of the fodder is wasted, and a distinct loss is incurred by allowing the fodder to dry out. The use of the silo enables the feeder to avoid these losses, for he can take the entire crop from the field just at the time when it contains the most digestible food value, place it under cover at the barn convenient for feeding, succulent, digestible, palatable, in such condition that it will all be consumed.

We value the silo as the source of an abundant supply of cheap, succulent food for the winter months or seasons of drouth. Silage, if properly put up, will keep for an indefinite time. We have fed it four years old as "good as new." It is worth while to have it on hand ready to supply the need at any time.

Silage Differs in Composition.

Many farmers seem to forget that the silo merely preserves what is put into it. One can never get anything out of a silo that he doesn't first put in. If soft, immature corn is put into a silo, the silage will be sour, washy stuff, with little "body" to it, and its feeding will be a disappointment. On the other hand, if good, mature, well-eared corn is siloed, the result will be a strong, nutritious food, highly satisfactory.

Chemical analysis of the corn plant shows that it nearly doubles in feeding value between the time it reaches its full growth (tasseled) and maturity. The feeding value of silage will correspond with the maturity of the corn siloed.

Silage Not a Perfect Food.

Probably most will agree that good blue grass pasture is the cheapest and most satisfactory, all-around food for growth or milk. Now, if we will compare the analyses of blue grass pasture and good silage, we will find them almost identical except in the matter of protein, in which element silage is deficient.

	Water.	Protein	Carbohydrates	Fat
Pasture grass	80	2.6	10.6	.5
Silage	79	1.2	11.8	.6

Fifteen Years' Experience With the Silo—Continued.

By comparing the analyses we will see that to make silage an economical food, and to get the most out of it, it is necessary to feed in connection with it some food rich in protein. It has been our experience that by using the succulent silage as a basis for our ration and adding sufficient protein to duplicate the analysis of pasture grass, we can have very nearly summer food and secure very nearly summer results in the winter. We have a theory that inasmuch as silage is a summer food—that is, has the succulence of summer food—summer conditions of warmth should be provided to go with the food. Nature in wisdom provides the succulent grasses for the warmth of summer and dried grasses for the cold of winter. Possibly many disappointments can be traced to a failure to provide suitable conditions for the feeding of silage.

Cost of Silage.

Silage is one of the cheapest foods the stockman can use. The cost of growing an acre of corn to maturity will be about as follows: Use of land, \$5; plowing, \$2; fitting, \$1; planting, 50 cents; seed, 25 cents; cultivating, \$1.25. Total cost of an acre of corn at maturity, \$10. It will be seen at once that these are very liberal allowances, giving the farmer a good income from his investment, and good wages for all time spent in producing the crop. On good land, with good care, in a fairly favorable season, a crop of 16 to 20 tons per acre is not at all unattainable, making the silage cost on the ground, 50 to 60 cents per ton. With modern machinery and good management, it can be put into the silo for 35 to 40 cents per ton. Indeed, with our large machinery and strong force of men, we have put it into the silo for less than 30 cents. Interest on the cost of a silo, and deterioration of the silo, will add 10 cents more, making the total cost of a ton of silage \$0.95 to \$1.10.

Fifty pounds of silage per day is a good ration for a grown animal. Forty days feed for a dollar! And an acre of good corn will feed three or four animals 200 days, or through the winter. Surely there is no cheaper food.

Filling the Silo.

We have found that we fill the silo much cheaper by using machinery of large size, and employing a sufficient force of men to keep it running to its full capacity. Our machine, which is a company affair, is a 24-inch "OHIO," and will handle about all the corn that can be got to it. Our force consists of five or six teams and wagons, according to the distance of hauling, six men in the field to load the wagons, two men at the cutter to help driver unload, and one man in the silo. The corn is cut with a harvester and tied in bundles as large as a man can lift. We divide our help in the field in to two companies or gangs, three men loading half the wagons and three the other half. Thus they are not in each other's way, and three men can hand the bundles up to the loader as fast as he can place them. We load the wagons beginning at the rear end, building up a tier of bundles against the rear standard, then another, till the load is completed, and placing them so that butts will be toward the machine in unloading. Loaded in this way the bundles do not overlap and bind each other, and three men at the machine, each taking a bundle in turn, and placing it in the cutter, can feed the largest machine to its full capacity, and unload a wagon in a surprisingly short time. In a trial we

Fifteen Years' Experience With the Silo—Continued.

have unloaded a 3800-pound load, cut it in $\frac{3}{4}$ -inch lengths, and elevated it into a 45-foot silo in a fraction over three minutes. With good corn we can put in 20 tons per hour, at a cost of less than 30 cents per ton. The more modern blower has many advantages over the old carrier and very rapid work may be done by some of the new machines.

Silage for Milk.

It is generally admitted that the silo is a good thing in the dairy. In the dairy section of Ohio it has found a place on most dairy farms and is considered indispensable, especially for winter milk. It is our practice to feed silage the year round, excepting perhaps a couple of months in the early summer, when the pasture is at its best, and we have come to value it nearly, if not quite, as highly to supplement summer pastures as for the winter ration.

Silage for Beef.

While most persons are now ready to admit that silage is a desirable food in the dairy, many yet question its value in the production of beef. Theoretically the ration that will produce a large flow of milk ought to promote the growth of the young beef animal. Our experience proves the truth of the theory so far as silage is concerned. Just as the milch cow in the winter approximates summer results in milk, when silage is used as a basis of the ration, so the young steer approximates summer results in growth on the same ration. We have had steers make an average gain of three pounds per day for a short time on a silage ration balanced with protein grain, such as the gluten feeds.

One thing has not been mentioned and that is the health and thrift of the animals, whether milch cows or steers. Our animals always shed in March, are always in condition and ready to make rapid gains on the first grass of spring. We have fed silage to horses, brood sows and poultry, with very satisfactory results.

Yours truly,

F. L. ALLEN.

Publishers' Note.

In talking with Ex-Governor Hoard of Wisconsin recently, he mentioned the fact that he has made a practice for the past three years of putting about 30 bbls. of water on top of his silage after filling, with very satisfactory results. It seems to settle the whole mass and especially the top, and causes a very thin crust to form, thus sealing the silo with scarcely a cart full of waste.

The "Ohio" Blower Machine will elevate the water and spread it over the top perfectly.

“Ohio” Standard Feed and Ensilage Cutter

Showing New Metal Bucket Carrier, Set for Right-Angle Delivery

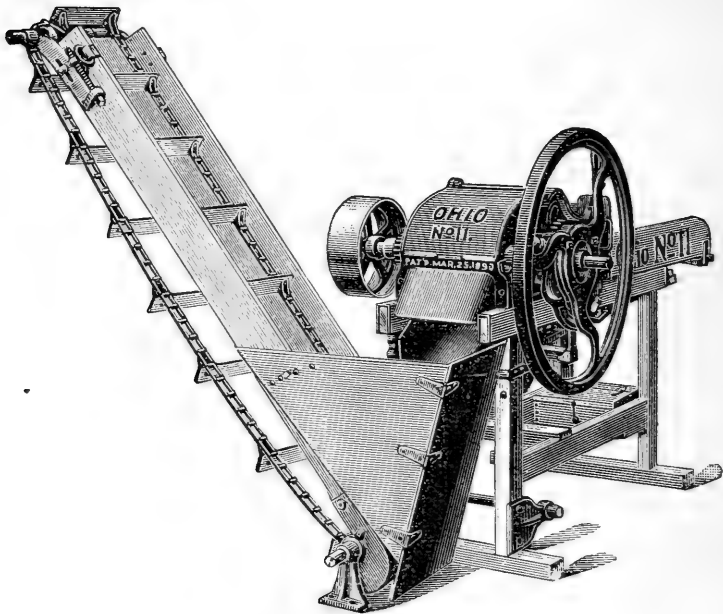

Fig. 784, No. 11

- No. 11 With two 11-in. knives, cuts $\frac{1}{2}$, 1, $1\frac{1}{2}$ and 2 inches, weight 440 lbs.....
- No. 11 With four 11-in. knives, cuts $\frac{1}{4}$, $\frac{1}{2}$, $\frac{3}{4}$ and 1 inch, weight 440 lbs.....

Reversible carrier with angle or straight delivery; also straight delivery carrier with reversible attachments, in 12-ft. lengths or more, can be supplied for these machines.

Extra Gears, to cut 4 inches long, with two knives, can also be furnished.

Machines are regularly equipped with four cutting knives, but when desired can be supplied with Shredder blades instead, at slight extra cost. Shredder blades are illustrated on page 238.

For full information, prices, etc., see our large Feed and Ensilage Cutter Catalog.

Smallest Size Ensilage Cutter.

The illustration on the opposite page is a good representation of the smallest size ensilage cutter and it shows also the new metal bucket carrier set for right angle delivery. This is the style carrier manufactured for this machine, and it can be set at right or left angle, or straightaway.

Construction of the Carrier.

The sides of the trough are tied together by wood strips and they are reinforced by iron rods. The hangers at top have adjustment which is to set the tension in the chain. The chain is malleable links of standard make, and the attachment link is our special design and admits of the bucket being full width of the trough. The buckets are heavy sheet metal and are two inches high. The metal hood at bottom and a tail piece under the chain catch the cut ensilage and prevent it spilling out. It will carry the ensilage away as fast as it comes from the machine.

Uses of Elevators.

The first and principal use of elevators of this kind is to convey cut ensilage into the silo. Other uses are to deliver dry cut feed, of whatever kind, into bays, bins, lofts, and other places away from the machine, which saves the expense of a man.

Has Capacity to Fill 50-ton Silos.

The cutter is substantial, has large capacity, and is adapted to cut all kinds of dry feed as well as ensilage. It has capacity to fill 50-ton silos, and even larger ones, but as this work necessitates a force of men and teams, and taking into account the liability of frost, owners of silos usually give preference to a larger machine, so that the cutting may be done quickly and not lag.

Shredding Fodder.

By substituting shredder blades for the cutting knives, perfect shredding can be accomplished. A sample of the shredded material as it comes from the machine is shown in the illustration on page 238. A full description accompanies the illustration.

Capacity.

Dry feed 2500 to 3000 pounds; ensilage, three to four tons per hour.

Speed.

450 to 600 revolutions per minute.

Power.

Two-horse.

Pulley.

Size sent 12x4-inch face; diameters, 6, 8, 10 and 15 inches can be furnished.

Weight.

No. 11 Cutter, 440 lbs. Reversible carrier, 12 feet long; 200 pounds; extensions, per foot, 8 pounds.

“Ohio” Standard Feed and Ensilage Cutter

Equipped with Self-Feed Table and Blower Elevator

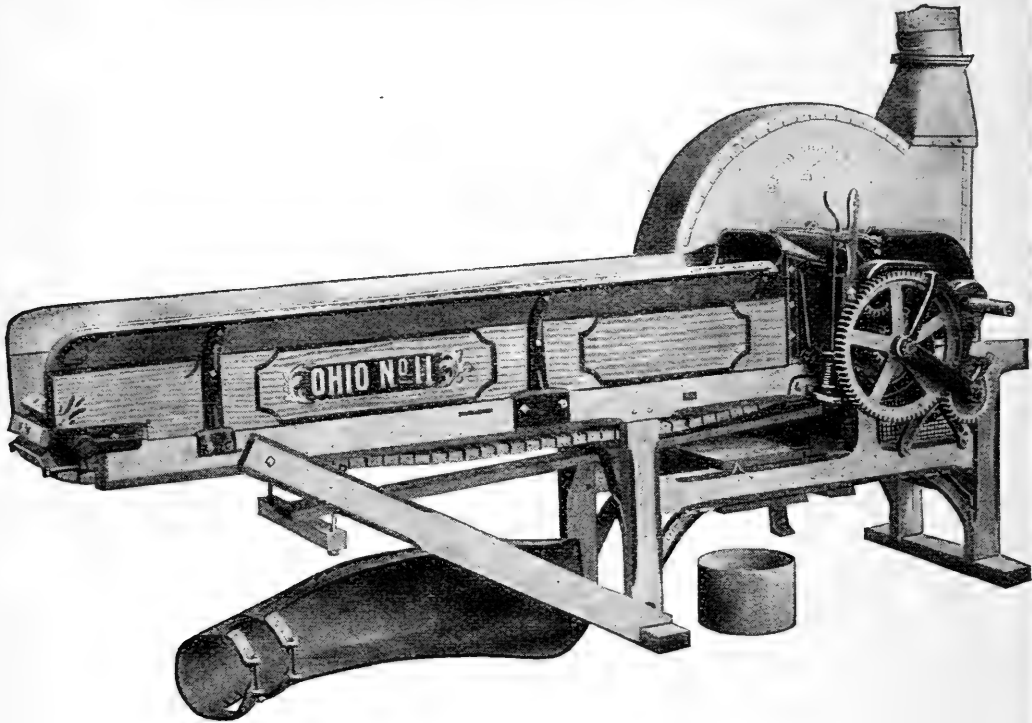

Fig. 803, No. 11

No. 11 Self Feed Cutter, complete as illustrated; weight
725 lbs.

No. 11 Plain Table Cutter complete; weight 925 lbs.....

These machines are equipped with Blower and Hood, but no pipe. They have two 11-inch knives and cut $\frac{1}{2}$, 1, $1\frac{1}{2}$ and 2 inches.

7-inch galvanized pipe comes in 4, 6 and 10-ft. lengths

Extra Gears, to cut 4 inches long, can be supplied.

Machines are regularly equipped with cutting knives, but when desired can be supplied with Shredder Blades instead, at slight extra cost. Shredder Blades are illustrated and described on page 238.

For full information and prices, see our large Feed and Ensilage Cutter catalog.

DESCRIPTION

The Illustration.

On the opposite page is shown our No. 11 Feed and Ensilage Cutter, equipped with Blower Elevator and Self Feed Table. This addition has been made in order to meet a growing demand for a Blower Cutter to be operated with light power—four to six horse. The machine is also made with plain table instead of Self-Feed.

Adaptability.

This Cutter has long been our most popular size for general farm use. It is adapted for cutting all kinds of dry feeds as well as ensilage, is strongly and durably built, has large capacity and requires but slight power to run.

Direct Blast Blower.

The fan wheel is heavy and carries three blades or paddles, which are fastened absolutely rigid. The fan case is made of heavy steel, and is closely riveted. The general construction is identical with that of the Blower so successfully used for the past eight years in connection with our "Monarch" Machines. An auger conveys the cut material into the Blower.

Materials and Construction.

The frame throughout is of the best hardwood, rigidly put together. It is nicely striped and finished in the natural; the iron work is maroon and the whole machine is varnished, giving a very attractive appearance. The knives are made of a high carbon steel, are carefully tempered and very durable. They are securely bolted to solid knife heads and are readily adjustable. The knife shaft is of steel, $1\frac{1}{2}$ inches in diameter. The shaft bearings are long and well babbitted. The feeding mechanism is excellent. As the upper feed roller rises to allow the feed to pass through, the cog wheels remain in proper mesh without binding, making an easy-running, durable device. The throwout or feed lever is also very simple and easy of operation. Its use enables the operator to stop the feed instantly in case of accident or otherwise.

The Pipe and Pipe Connections.

The pipe is 7 inches in diameter and is made of galvanized steel with standing seam on the outside, running lengthwise, being very rigid. It is made in 4, 6 and 10-foot lengths with 7-inch slip joints and a clamping band at each joint. A swivel joint connection at the fan case allows the pipe to turn in any direction. Included with each machine is a hood or elbow which is to connect to upper end of pipe and convey the cut ensilage into the silo.

Set Pipe Nearly Perpendicular for Ensilage;

Dry Feed Can Be Blown in Any Direction.

If lateral delivery is desired, suitable elbows can be furnished at slight cost. For green silage it is necessary to carry the pipe nearly perpendicular to height of opening and the hood at top will direct the silage into silo. Dry cut or shredded fodder may be blown in almost any direction by proper use of suitable elbows.

Shredding Fodder.

The new patented shredder blade should be run at 600 to 700 revolutions per minute while shredding, and is a notable advance in construction, enabling the operator to shred dry fodder or corn stover with the blower. There is a great saving in power also, as compared with the tooth or saw-blade type of shredder, besides saving the leaves in much better condition. See illustration of shredded material on page 238.

Capacity.

The machine will cut and elevate from 3 to 5 tons ensilage per hour.

Power.

Plain table, 5 or 6 horse; Self Feed, 6 or 7 horse.

Speed.

650 to 750 revolutions per minute.

Pulleys.

10 in. diameter by 6 in. face. Choice of other diameters when wanted.

“Ohio” Monarch Self-Feed Ensilage Cutter

Showing New Metal Bucket Swivel Carrier

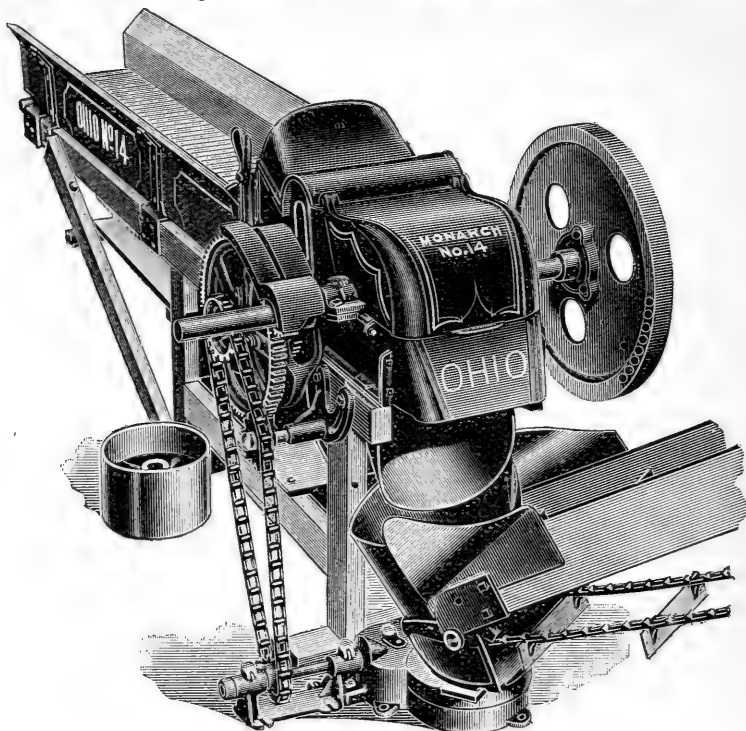

Fig. 794, Nos. 12, 14, 17, 19 and 22

- No. 12 Cuts $\frac{1}{4}$ in., $\frac{1}{2}$ in., $\frac{3}{4}$ in. and 1 in.; weight 1000 lbs.
- No. 14 Cuts $\frac{1}{4}$ in., $\frac{1}{2}$ in., $\frac{3}{4}$ in. and 1 in.; weight 1050 lbs.
- No. 17 Cuts $\frac{1}{4}$ in., $\frac{1}{2}$ in., $\frac{3}{4}$ in. and 1 in.; weight 1100 lbs.
- No. 19 Cuts $\frac{1}{4}$ in., $\frac{1}{2}$ in., $\frac{3}{4}$ in. and 1 in.; weight 1150 lbs.
- No. 22 Cuts $\frac{1}{4}$ in., $\frac{1}{2}$ in., $\frac{3}{4}$ in. and 1 in.; weight 1200 lbs.

12-ft. Straight Carrier for Nos. 12, 14 and 17; 240 lbs.

12-ft. Straight Carrier for Nos. 19 and 22; 355 lbs.

12-ft. Swivel Carrier for Nos. 12, 14, and 17; 315 lbs.

12-ft. Swivel Carrier for Nos. 19 and 22; 480 lbs.

Carrier over 12 ft. for Nos. 12, 14 and 17 per ft; 10 lbs.

Carrier over 12 ft. for Nos. 19 and 22; 14 lbs.

Wood cover for Carrier, with hooks and eyes to fasten, can be furnished for all sizes.

Extra Gears, to cut 4 inches long, with two knives, can also be supplied.

Machines are regularly equipped with four cutting knives, but when desired can be supplied with Shredder Blades instead at slight extra cost. Shredder blades are illustrated on page 238.

For full information, prices, etc., see our large Feed and Ensilage Cutter Catalog.

The illustration opposite shows a No. 17 "Ohio" Monarch Self-feed Cutter with metal bucket swivel carrier attached. Carriers are furnished in any length that may be required.

The machines are made in five sizes, with capacities and required powers as listed below.

They are also manufactured with Blower Elevator, as shown in illustration on page 234.

The "Ohio" machines are supreme in the Ensilage Cutter field, due to their wonderful capacity, great durability and easy-running-and-feeding qualities.

It is significant that the "Ohio" self-feed mechanism has been copied by all other manufacturers, which proves its value. The table is 8 feet long, and the largest bundles of corn can be thrown on it and without further attention are carried to the feed rolls and thence to the knives.

No. 12—Capacity, 8 to 10 tons per hour; power, 4 to 6 horse steam.

No. 14—Capacity, 12 to 15 tons per hour; power, 4 to 6 horse steam.

No. 17—Capacity, 15 to 20 tons per hour; power, 6 to 8 horse steam.

No. 19—Capacity, 20 to 25 tons per hour; power, 8 to 10 horse steam.

No. 22—Capacity, 25 to 30 tons per hour; power, 10 to 12 horse steam.

Speed—450 to 600 revolutions per minute, pulley 12x6 inches; choice of other diameters when wanted.

"Ohio" Monarch Self-Feed Ensilage Cutter

With Blower Elevator

This is a very fine view of the machine in its entirety. The hood over the cutting cylinder is closed down ready for action. The gearing is protected by guards, as shown.

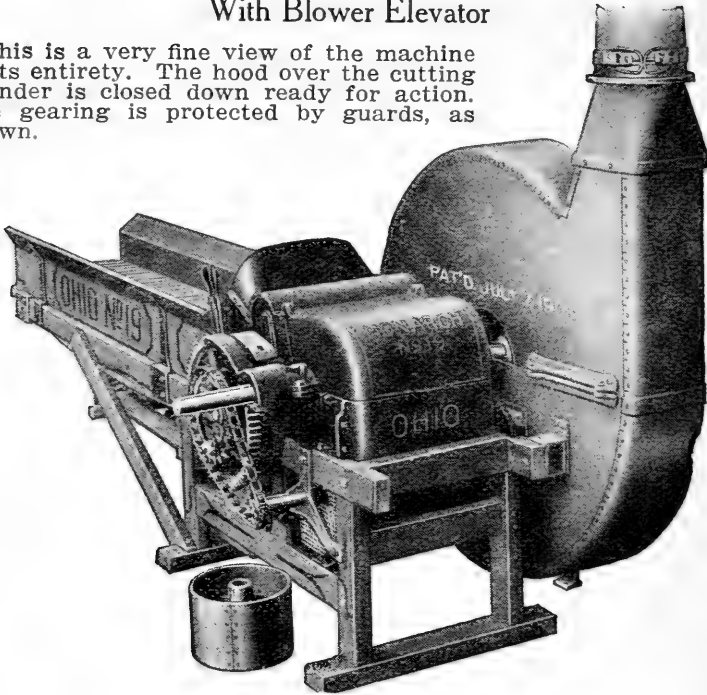

Fig. 802, Nos. 19 and 22

- No. 12 Cuts $\frac{1}{4}$ in., $\frac{1}{2}$ in., $\frac{3}{4}$ in. and 1 in.; weight 1500 lbs.
- No. 14 Cuts $\frac{1}{4}$ in., $\frac{1}{2}$ in., $\frac{3}{4}$ in. and 1 in.; weight 1550 lbs.
- No. 17 Cuts $\frac{1}{4}$ in., $\frac{1}{2}$ in., $\frac{3}{4}$ in. and 1 in.; weight 1600 lbs.
- No. 19 Cuts $\frac{1}{4}$ in., $\frac{1}{2}$ in., $\frac{3}{4}$ in. and 1 in.; weight 1650 lbs.
- No. 22 Cuts $\frac{1}{4}$ in., $\frac{1}{2}$ in., $\frac{3}{4}$ in. and 1 in.; weight 1700 lbs.

Regular equipment for above machines includes blower, covered pulley and distributor, but no pipe.

10-inch galvanized pipe comes in 4, 6, 8 and 10-foot lengths (weight 4 pounds to foot.)

Extra gears, to cut 4 inches long, with 2 knives, can also be furnished.

Machines are regularly equipped with 4 cutting knives, but when desired, can be supplied with shredder blades instead, at slight extra cost.

Shredder blades are illustrated on page 238.

For full information, prices, etc., see our large Feed and Ensilage Cutter Catalog.

The machine illustrated on opposite page is representative of the "Ohio" Monarch Self-feed Blower Ensilage Cutter. As previously stated, these machines are made in five sizes, Nos. 12, 14, 17, 19 and 22; the blower is a part of the machine.

The construction throughout is heavy and powerful. The frame is strong and rigidly put together; the steel knife shaft is heavy, running clear through the machine and carrying the drive pulley, knife heads and fly wheel. Four steel paddles are fastened to this fly wheel, in such a way that it is absolutely impossible for them to become loosened in any way. A heavy, well-riveted sheet steel fan case acts as a covering for the whole.

The characteristic feature of the "Ohio" Monarch Blower is its immense capacity, using so little power. The power is applied primarily to the main shaft, and all the heavy work—cutting and elevating—is done direct from this shaft, so that not an ounce of power is wasted through short belts, transmission gears, etc. Moreover, the liability of breakage and wear is reduced to a minimum.

The pipe is 10 inches in diameter, in convenient lengths, and made of galvanized steel. A swivel joint connection of the fan case allows it to turn in any direction.

The new patented "Ohio" silage distributor (see page 237) is included with each machine.

No. 12—Capacity, 8 to 10 tons per hour; 6 to 8 horse power.

No. 14—Capacity, 12 to 15 tons per hour; 8 to 10 horse power.

No. 17—Capacity, 15 to 20 tons per hour; 10 to 12 horse power.

No. 19—Capacity, 20 to 25 tons per hour; 12 to 14 horse power.

No. 22—Capacity, 25 to 30 tons per hour; 14 to 16 horse power.

Speed—650 to 700 revolutions per minute. Pulley 12x8 inches, leather covered. Choice of other diameters when wanted.

New Steel Truck

For Mounting "Ohio" Ensilage Cutters

Fig. 815

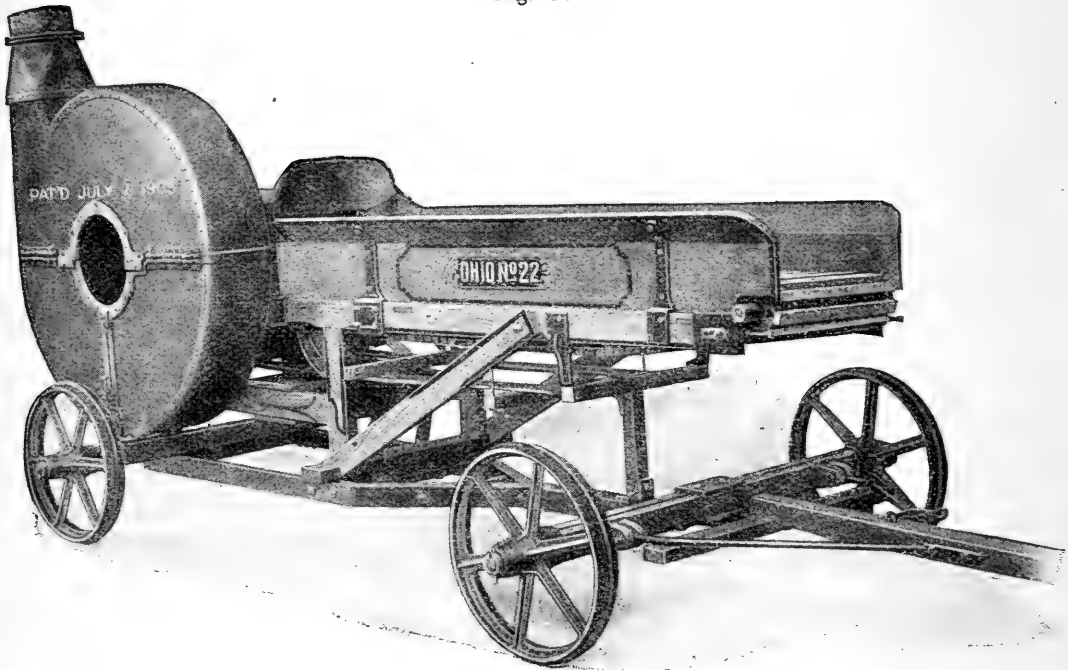

This new steel truck is suitable for mounting all sizes of "Ohio" Silage Cutters with traveling feed tables, both Blower and Carrier style, and it is recommended as a thoroughly practical, economical and satisfactory mounting for all parties who wish to move their machines frequently or regularly. All parts are interchangeable, and in case of accident may be readily replaced.

Full description and price in our Feed and Ensilage Cutter Catalog.

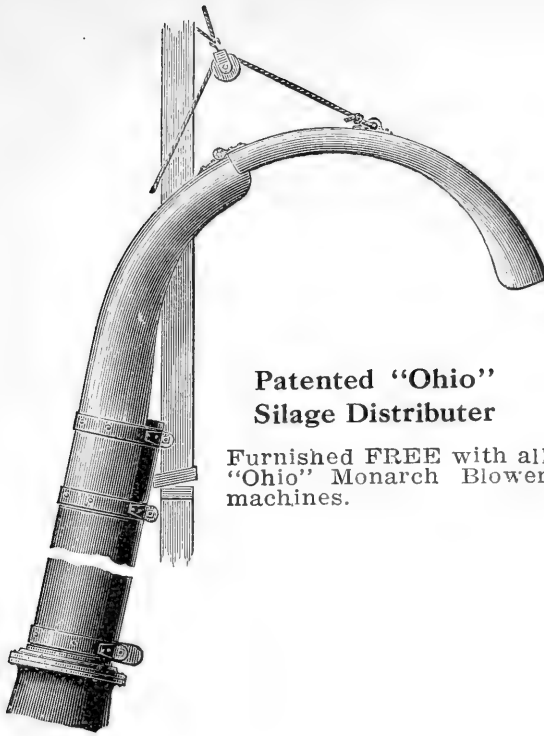

Patented "Ohio" Silage Distributer

Furnished FREE with all
"Ohio" Monarch Blower
machines.



New
Silo
Tube

"Ohio" Silage Distributer. The new distributor furnished with each machine is a curved, jointed elbow, 5 feet long, open on the outer side so as to prevent back pressure. Firmest attachment to the pipe is secured by two clamping bands around the upper end of the pipe. There is a hinged joint at the middle of the curve, which allows the outer end to be raised and lowered by means of a rope reaching to the ground, thus directing the cut material toward any point across the silo. By means of the swivel at the bottom of the pipe the hood can be turned to the right or left and in this manner the cut ensilage may be evenly distributed over the entire silo during the process of filling. This device is patented, and a distinctive feature to be had only with "Ohio" Blowers.

Our New Silo Tube can be hung from the distributor or roof of silo. It catches the silage and delivers it in a compact mass at the bottom of the silo. This insures perfectly equal distribution of the cut feed, the leaves, moisture and heavier parts being always uniformly mixed as cut. It is flexible in character and is to be guided by hand. The man inside the silo will appreciate this tube, as its use eliminates the objectionable features heretofore connected with his part of the work.

Important!

The cut ensilage should be directed to the outer edge of the silo at all times, thus keeping it high and packing it there, letting the center take care of itself. The weight of the silage packs it in the center.

The New "Ohio" Shredder

Showing a Sample of Shredded Corn Stalks



Speed, 600 to 700 revolutions

The illustration above shows a regular "Ohio" machine equipped with our Patented Shredder Blades instead of with Knives. These Shredder Blades are interchangeable with cutting Knives on all sizes of cutters from No. 9 up, so that by purchasing the Blades extra the user has two machines in one, with little extra cost.

When shredded properly, corn is much more readily eaten and with much less waste than when fed whole. Shredded dry fodder is considered much better than dry cut fodder, for the reason that it is split and torn, thus doing away with the troublesome sharp edges.

The new Shredder Blade successfully reduces the fodder to the proper condition, with the same power, speed and capacity as the regular "Ohio" Cutter. The blades have projecting steel teeth—no two in succession travel in the same path. Unlike the saw-blade or tooth Shredders, they do not pulverize and waste the leaves, but split and tear the stalks perfectly. The shredded corn in the picture was made with two blades on the cylinder and it is reduced to a nice condition; hence four blades will shred it much finer.

The greatest saving in this new shredder is that perfect work can be done at normal speed (600 to 700 revolutions), which means that the same power which runs the cutter will run the shredder—and that nothing extra but the shredder blades are needed to make two machines in one.

OFFICE OF THE SILVER MFG. CO.

Salem, Ohio, U. S. A., Jan. 1, 1911.

In issuing the foregoing we have spared neither pains nor expense in producing reliable data and information from best authorities in order to produce a book entirely comprehensive and worthy of the subject.

In testimony of our efforts we mention with some pride that "Modern Silage Methods" has been furnished on many occasions to be used as a Text Book in the classes of our Agricultural Colleges throughout the States and recently the plates were furnished on request to the Director General of Agriculture at Lisbon for the purpose of reproducing the book in the Portuguese language.

We charge a nominal price merely to help pay postage and to keep curiosity seekers and others not directly interested from answering our advertisements.

We do not make silos of any description.

In describing our machines we have endeavored to give in condensed form such information as would enable beginners and others interested to form an estimate of what their cutting equipment would cost, and if the reader contemplates the purchase of an ensilage cutter, we ask that the merits of the "Ohio" be investigated. We solicit your inquiries regarding cutting outfits and shall be glad to supply latest catalog upon application.

Respectfully,

THE SILVER MANUFACTURING CO.

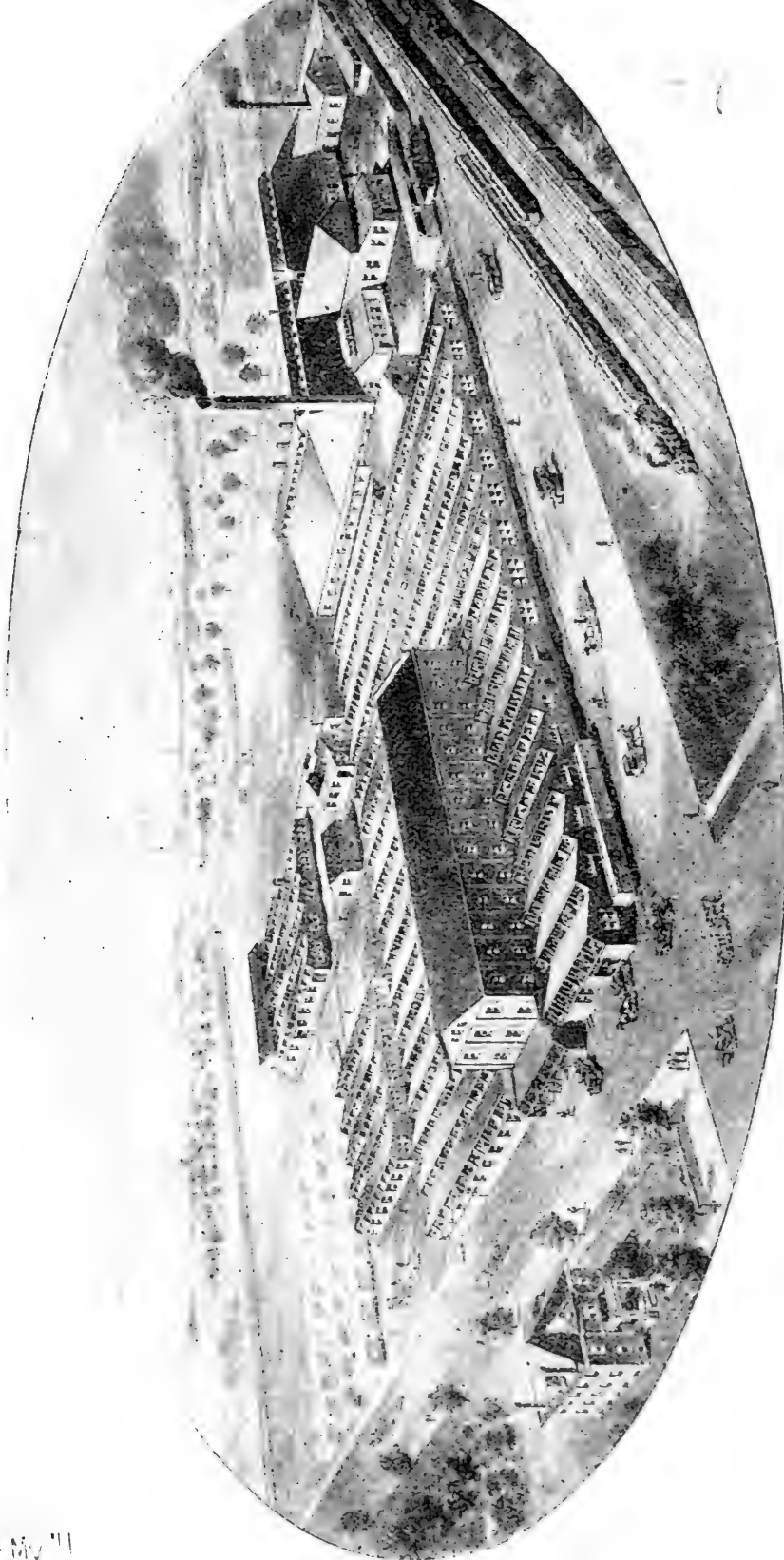

View of Head Office and Works of The Silver Manufacturing Co.

Located in Salem, Ohio, U. S. A., showing switch connections with the Pennsylvania and Erie Railroads. This is the home of "Ohio" Ensilage Cutters.

The plant is new and modern in every particular, having been thoroughly remodeled and greatly enlarged during the past year. The machine shop and erecting room alone have a ground floor space of approximately one acre.



MODERN SILAGE METHODS



EIGHTH EDITION
REVISED TO DATE

Published by THE SILVER MFG. CO., Salem, Ohio, U.S.A.

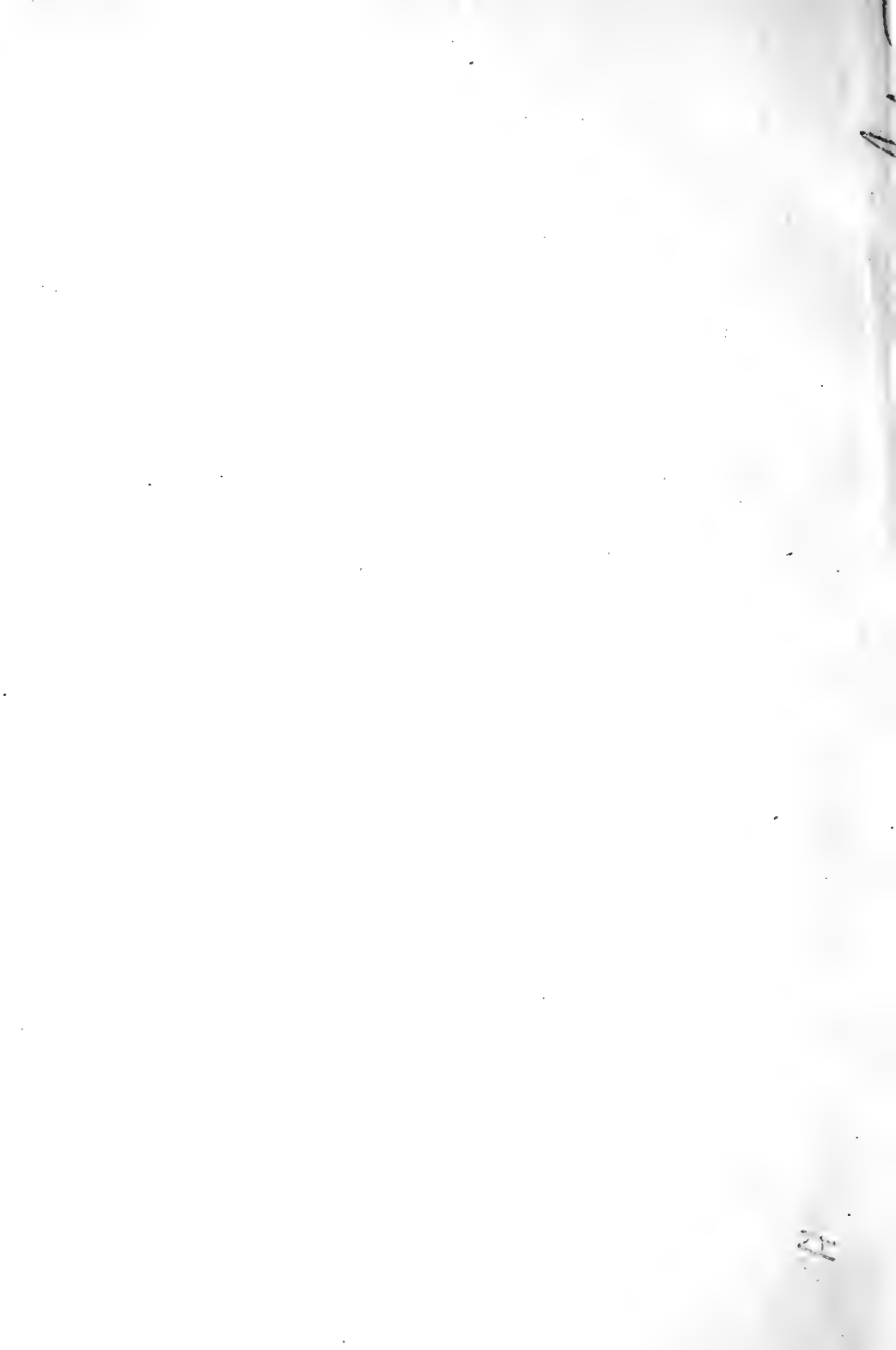

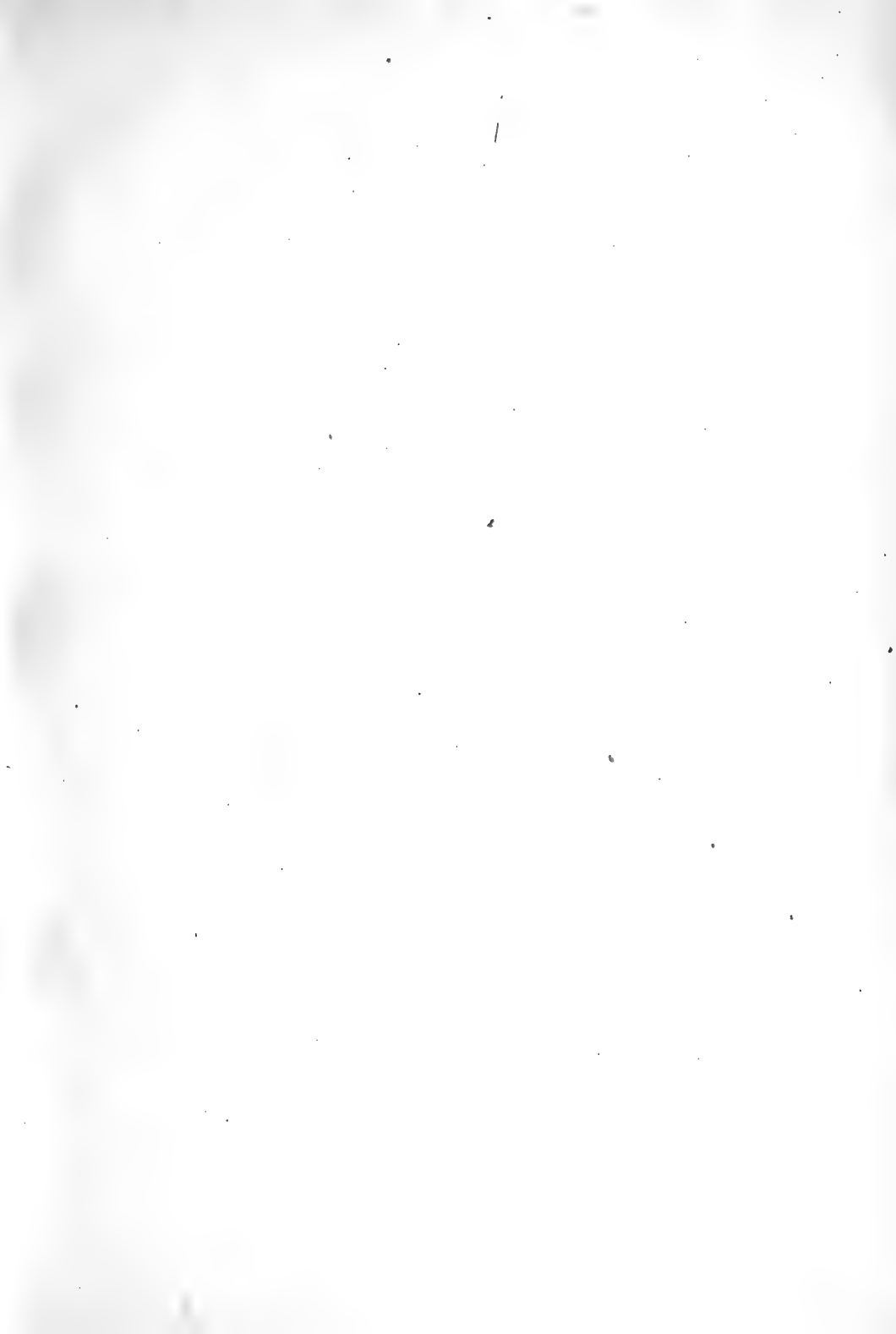





LIBRARY OF CONGRESS



00027661051