

6K  
617  
.32

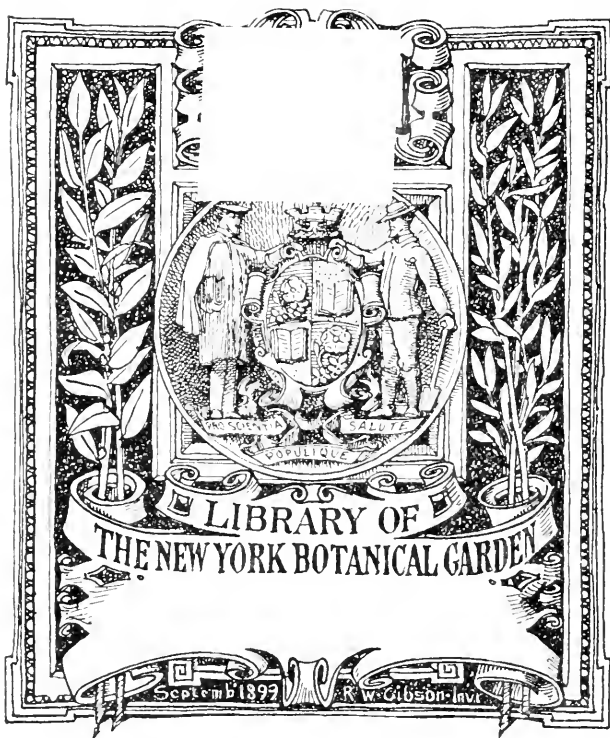









# MUSHROOMS

## AND THEIR USE

BY CHARLES H. PECK,

STATE BOTANIST OF NEW YORK

---

PRICE, FIFTY CENTS

---

CAMBRIDGE, MASS.  
CAMBRIDGE BOTANICAL SUPPLY COMPANY

MAY, 1897



## EXHIBITIONS OF MUSHROOMS.

---

Saturdays during the season, from 12 to 3, our native mushrooms, edible and poisonous, will be shown at the regular exhibitions of the Massachusetts Horticultural Society.

These exhibitions are one feature of the work of the Boston Mycological Club, which is using every means to collect and spread such information as is to be found in Prof. Peck's articles. Membership in the club is \$1.00 a year, and all interested are welcomed. The Secretary may be addressed at Cambridge, Mass.







# MUSHROOMS

AND

# THEIR USE

BY

CHARLES H. PECK,

STATE BOTANIST OF NEW YORK.

Reprinted by permission from the *CULTIVATOR AND COUNTRY GENTLEMAN*, of Albany, N. Y., May 31 to Sept. 20, 1894.

**ILLUSTRATED BY 32 CUTS**

loaned by the publishers of that journal.

CAMBRIDGE, MASS.

CAMBRIDGE BOTANICAL SUPPLY COMPANY.

MAY, 1897.

QK617

.P32

## MUSHROOMS AND THEIR USE.

### I. AND II. INTRODUCTION—GENERAL STATEMENTS.

Many articles on mushrooms have recently appeared in periodicals in this country, from which it is evident that there is a desire on the part of many persons to obtain information concerning them. It has, therefore, seemed good to me to tell what little I know about the subject, even at the risk of taking up what may appear to some a matter already well discussed. I am the more strongly inclined to do this because of numerous private appeals to me for information of this character, and because no single periodical can hope to reach all the people in this vast country who desire information on such an interesting topic. Besides, no single writer is likely to exhaust the subject, or to tell all that should be known concerning it; what one may omit another may express, and in this way general knowledge may be increased.

The times seem auspicious for such an undertaking, for with much depression in financial and business circles, with lack of employment and the reduction in wages now taking place, anything that promises to cheapen the cost of living or add to the means of subsistence of the unemployed or of those employed on short time or at low wages, must possess a peculiar interest. "Hard times" may now and then compel us to look into Nature's bountiful storehouse for a supplementary supply of food. And Nature, almost always lavish in her gifts, has indeed provided a bountiful supply, which in this country has been greatly overlooked and almost entirely neglected until very recent years.

Mushrooms have been, and still are, much more largely consumed in Europe than in this country. In China also, where, with her teeming population, the cost of living seems to be reduced almost to its minimum, they are extensively used. China itself does not supply its own demand for them, and therefore

they import large quantities from Japan and other islands of the Pacific ocean. In some of the cities of Europe, the consumption of them is so great that a superintendent of the market is employed to inspect those offered for sale, and to destroy those that are unwholesome or unfit for food. In this way it has been ascertained that more than thirty tons are annually consumed in Rome alone! They are not used by the poorer classes of people exclusively, for the wealthy and the nobility are apparently as fond of them as any other class. They are served at the tables of the hotels and on great occasions.

In this country, the high price of the common or cultivated mushroom (usually fifty cents to a dollar a pound) excludes it from the tables of the poor who live in cities or where they are unable to gather it in the wild state; but, fortunately for them, there are many other species quite as good as this, which it is possible to have in the season for the trouble of gathering. No labor is expended in their cultivation, no costly hot-houses or mushroom cellars are occupied by them; nature produces them at her own expense, and often in great abundance. They afford palatable and nutritious food; and yet they are generally allowed to decay where they grew. In this state alone, at least seventy-five species are known to occur that are available for food. There are here also nearly six hundred other fleshy or similar fungi, many of which will doubtless yet be found to be edible. Experimenters are already in the field, and additions are frequently made to the esculent list. It is true that some are of small size, or of rare occurrence or limited range; but others occur with frequency, are of fair size and wide range, and in favorable seasons and localities are found in great profusion. Some occur early in the season, others in midsummer, and many in late summer and in autumn; so that there is a succession of crops, which in wet seasons at least make an almost continuous supply possible.

They constitute a very nutritious and sustaining diet. Chemical analysis, as well as experience, indicates this. The former has shown that they contain in their dry matter from 20 to 50 per cent. of protein or nitrogenous material, and they may therefore be called a vegetable meat, and be used as a substitute for animal food.

Like other vegetables, they are largely composed of water, which generally constitutes 80 or 90 per cent. of the whole. So much water causes them to shrivel greatly in drying, and so much nitrogenous material induces rapid decay and loathsome

decomposition, unless quickly dried and kept dry. This should teach moderation in their use. A hearty meal of mushrooms alone might be expected to produce consequences similar to those following a large repast on nothing but beef-steak. It also teaches the necessity of care in the selection of the specimens to be utilized. Only sound and fresh specimens, young or just mature, should be taken.

Many insects are fond of mushrooms. Both they and their larvæ feed on them and in them. A mushroom may appear fair on its exterior, which if cut or broken, will show its interior to be full of small holes and galleries excavated by larvæ, and perhaps may reveal a living colony of the larvæ themselves. It is needless to say that such specimens should be rejected at once. The larvæ most often enter at the base of the stem and mine their way up through the stem to the cap. When this is the case, and they have reached the cap, their presence will be revealed when the cap is cut from the stem, for the small holes through which they have passed will easily be seen. Sometimes the eggs are deposited by the parent insect on the surface of the cap, and when hatched, the larvæ at once eat their way into the flesh beneath.

Strange as it may seem, a colony of larvæ in the lower part of the stem of a mushroom will often affect disastrously the flavor of the cap or upper part, which they have not yet touched. Sometimes a part of a cap will show signs of decay while a part remains apparently sound. Better reject the whole in such cases. Also discard those that are water-soaked, for this is often an indication of age and incipient decay.

The fact that most mushrooms are short-lived and decay rapidly also teaches the importance of cooking them promptly after they have been gathered. As a rule, they should be cooked the same day. If the collector has been fortunate enough to obtain more than enough for one meal, it is generally better to cook the whole lot at once, as they will not spoil as soon in the cooked as in the raw state.

In collecting mushrooms that have stems, it is not advisable to take the stems except in those cases in which they are sufficiently tender to be utilized; generally, they are too tough. Care should be taken to keep the mushrooms as clean as possible. Sometimes soil, sticks and leaves, are carried up in the growth of the mushroom and remain on the cap. This is especially the case with those species that have a viscid or sticky surface to the cap. It is better to clear this rubbish carefully away before putting the specimens in the collecting basket. If this is not done, such

specimens should at least be wrapped separately in paper, that they may not soil others.

In preparing for cooking, all having a dirty, tough or viscid cuticle, should be thoroughly washed or wiped clean or peeled. In the case of boleti, it is well to remove the porous part from the cap, for these pores are apt to form a shiny, unpleasant mass in cooking. They are easily separable from the flesh of the cap. In large specimens the cap may be cut in slices.

The mode of cooking will depend on the kind of mushroom, the tastes of those that are to eat them, and the conveniences at hand. It is customary to fry, broil or stew them, and in each case to season or dress them according to taste, or the knowledge of the cook. The object to be kept in view is to make a palatable and at the same time a digestible dish. Sometimes mushrooms are used in small quantity, chiefly to give flavor to meats or other dishes. Mushrooms of inferior flavor are often made more agreeable by cooking with them a few specimens of some kind more highly and agreeably flavored. Species too tough to be eaten with pleasure are sometimes utilized by making of them a kind of soup or broth, which is eaten, while the mushroom itself is rejected.

The same species is not always equally tender or agreeable. Its flavor and texture appear to depend to some extent upon the kind of soil in which it grew, the rapidity of its growth, and the age at which it was collected. Young specimens and those of rapid growth are expected to be more tender than old or slowly developed ones, but they are not always the most highly flavored. In this way, and because of the differences in the tastes of individuals, we may explain the different estimates placed by different writers on the edible qualities of the same species of mushroom. There are also peculiarities of constitution which make what is one man's meat, another man's poison.

The same thing is sometimes seen in the use of other foods. One man is made sick by eating egg or any article of food in the preparation of which egg enters as an ingredient. Another man cannot eat strawberries without being sickened. This individual peculiarity has possibly, in some instances, been the reason why one writer has attributed poisonous qualities to the same kind of mushroom which another writer has declared to be edible.

Mushrooms have been used for food for many centuries. They graced the tables of the ancient Greeks and Romans. Accidents have sometimes happened from their careless or unintelligent use; yet some people have persisted in using them, and

probably will persist in it as long as they can be obtained. To diminish the number of such accidents by cultivating a better general knowledge of the subject is one of the purposes of the writer. It is true that there are some poisonous species, dangerous to eat; but the number of such species is often greatly overestimated. Probably the proportion of dangerously poisonous species is no greater among fungi than among flowering plants. In this State only three or four species have been found that may be classed as actually known to be fatally poisonous. There are many that are of such a character as to produce nausea, vomiting and derangement of the digestive organs, but they are not to be classed as really dangerous to life. They are unwholesome because of their persistently bitter, acid or otherwise disagreeable flavor, or because of toughness of texture, or the possession of some quality repugnant to the stomach, but not necessarily causing death, for if such are eaten, the irritation produced generally induces their speedy rejection from the system, and then the normal condition of the victim is soon restored.

On the other hand the dangerously poisonous species appear to cause no irritation or unpleasant symptoms until after the lapse of several hours after eating, usually from eight to fifteen. The poisonous property, which has received the names amanitine, bulbosine, or muscarine, according to the kind of fungus from which it was obtained, appears to enter into the circulation and to attack the nervous system. Then the symptoms begin to manifest themselves. The face exhibits an ashy paleness; there is distress in the region of the stomach; nausea, vomiting and relaxation of the bowels follow, the extremities become cold, the pulse feeble, the eyesight is affected, and finally stupor and death follow if relief is not obtained. Atropine has been found to be an antidote to this kind of poisoning. It has been administered in doses of 1-60 to 1-3 of a grain according to the severity of the case, and the dose may be repeated if necessary. It may be administered in subcutaneous injections. In other cases the symptoms appear much sooner, and relief may be hastened by the administration of some simple emetic.

It is the fear of being poisoned that prevents many from using mushrooms. They are unable to distinguish the good from the bad, and therefore wisely avoid both. The erroneous opinion is often entertained that the poisonous species are about as numerous as the edible. Many also suppose that some simple test may be employed which will reveal the character of the mushrooms and show whether they are hurtful or harmless. Hence the oft-

repeated question, "How shall I distinguish the mushroom from the toadstool?" In the effort to answer this question, many rules have been given by various writers, some of which are wholly unreliable; and to the others there are so many exceptions that they are practically worthless. The only safe and reasonable way to distinguish between the good and the bad is to recognize each species by its own specific characters. It is in this way that we recognize the useful and esculent species among flowering plants, and it must be in this way that we select our edible species of mushrooms. A little more care may be necessary in one case than in the other, because of a closer resemblance between good and bad fungi than between good and bad flowering plants. The principle that is to govern in this matter is the same in both cases. The greater the number of esculent species clearly and confidently recognizable by any one, the greater the field from which he may draw his supplies. If but a single species is known, he can safely eat of that species only, unless he may be able to avail himself of the wider knowledge of some other person. In a few cases it is possible to affirm of certain groups or families of closely related species that no dangerous ones are known in them. For example, we have six species of morel in New York, and no morel is known to be really poisonous. It is, therefore, pretty safe to say that he who is able to distinguish a morel from all other fungi may confidently eat morels without fear of ill results, though he may not be able to separate one species of morel from another.

The same thing may be said of puff-balls. Any one able to discriminate between puff-balls and other fungi, may with considerable assurance make use of puff-balls when in proper condition, even if he does not know the real distinctive characters of any one species. The probability is that he will not thereby be poisoned; but there is not absolute safety. It is possible that some deleterious puff-ball of great scarcity exists which has not yet been discovered, or which, if known, has not yet been tested. Therefore, it is safer, even in these cases, to partake only of those which are specifically known, and which have been found by actual experiment, to be good for food. The rules which say that all morels, all puff-balls, all fairy-clubs, and all tender hydna or spine mushrooms are safe eating, would be better if limited by the words, "so far as known."

Many rules have been published by authors and writers for periodicals which have an extremely limited application, and are, therefore, misleading, and worse than useless. A writer,



wishing to limit the use of fungi to the common mushroom, says, "reject all which have the gills white." This rule, if observed, would exclude from use many excellent species. Another says, "discard all that have a hollow stem." This also would prevent the use of such valuable species as Caesar's mushroom, the smooth lepiota, and the delicious lactarius. Again, we are told to avoid all that have a viscid cap, and all that when fresh have an acrid or hot, peppery taste. These directions, too, would rule out some species that have been used and are known to furnish very good food.

The viscosity may be removed from the cap, the harsh flavor destroyed by cooking, and the flesh of some such has been found to be palatable and nutritious. Also, if we follow the directions to take only such species as are found growing in the fields and open places, we deprive ourselves of many an excellent dish that can be furnished by the edible species of the woods and groves.

The silver spoon test, which sanctions eating such as do not tarnish the spoon when placed among the cooking mushrooms, was long ago exploded, for by actual trial it was found to be deceptive and unreliable. It has been stated that vinegar has the power to absorb or neutralize the poison of the dangerous species, and that such, after having been steeped in vinegar, then taken out and washed in clean water, may be cooked and eaten with safety. This process is not here recommended. It seems better to eat only such as are known to be harmless, without any pickling process being necessary to make them so.

Before proceeding to the descriptive part of these articles, it is proper to explain the meaning of a few somewhat technical terms which it will be necessary or convenient to employ:

The substance of mushrooms is commonly called the *flesh*, though it is unlike the flesh of animals.

The seeds or reproductive bodies are termed *spores*. They are as fine as dust and singly invisible to the naked eye.

The upper expanded part of the plant is commonly known as the *cap*. The botanical name is *pileus*. It varies in shape according to age and species.

The spores develop in or on some special part of the cap, in all species where a cap is formed. The spore-bearing part of surface is botanically designated by the term *hymenium*, and that part on which the hymenium is borne or rests is the *hymenophore*.

The minute threads which proceed from the germinating spores, and which permeate the soil or other material on which

the mushroom grows, constitute the *mycelium*. This is commonly known as "spawn."

The best way to acquire a knowledge of our edible fungi is to study them in the light of the primary characters employed in botanical classification, and in their natural relations to each other. The species will, therefore, be described and arranged in their respective classes, families and genera. It will be seen that they are all included in three great classes, whose names and distinguishing characters may be stated in the following manner:

GASTEROMYCETEE.—Fungi whose spores are produced in the interior of the plant. Example, *puff balls*.

DISCOMYCETEE.—Fungi whose spores are produced in delicate membranous sacks on the upper or exterior surface of the cap. Example, *morels*.

HYMENOMYCETEE.—Fungi whose spores are produced on the lower surface of the cap. Example, *common mushroom*.

In this last class there are a few species in which no regular cap is developed. In these, the spores are produced on the exterior surface of upright, simple stem-like plants, or of the branches of upright bush-like plants, or on the upper surface of gelatinous or jelly-like irregularly expanded plants. None of the gelatinous plants will be described, and only two or three species of the other exceptional cases, all of which belong to the genus *Clavaria*.

The spore-bearing surface or hymenium is generally recognizable, even to the naked eye, by its smooth, delicate, waxy appearance, which is quite unlike that of the sterile surfaces. In most of the cap-bearing mushrooms, the lower surface of the cap is furnished with special organs, on whose surfaces the spores are produced. These are in the form of gills, pores or spine-like teeth, and these furnish characters on which the three principal families of the Hymenomycetæ are founded. These characters will be more fully elucidated in their proper place.

### III. PUFF-BALLS.

Puff-balls belong to a class of fungi to which botanists give the name *Gasteromyceles*, "stomach fungi"—a name suggested by the fact that their spores are produced within the receptacle, or spore-bearing part. In most of them, the whole interior of the mature plant is filled with a dusty mass of spores, intermingled in many cases with minute threads or filaments. They are among the most easily recognized of our fungi, and the larger ones in their early state are among the best of our edible species.

Almost every one, whether botanist or not, confidently thinks he knows a puff-ball when he sees it. Over and over again, the little globular growths consisting of a papery envelope stuffed full of brown dust and cottony filaments have been seen lying singly or in clusters on the ground, or adhering to the decaying wood of old stumps or prostrate trunks of trees. Often in childhood days these have been subjected to sudden pressure between the thumb and fingers, that there might be seen the little cloud of dust-like spores that is thereby ejected, and that quickly vanishes in the air like a little puff of smoke.

No one would think these good to eat, and indeed they are not, when in this condition. Nearly all puff-balls are white within when young, and their substance is then of a soft, fleshy consistence, very unlike the dusty filamentous material that fills them when mature. *And it is only while they are white within that they are fit for food.* When they reach maturity, the flesh at first assumes greenish-yellow or brownish-yellow hues. They are then spoiled for eating. Soon they become moist within, and when this moisture dries away, the whole interior (except in some species a small cellular part at the base) is found to be transformed into the usual dusty brown mass that characterizes the mature puff-ball.

There are in this country many species of the genus *Lycoperdon*, to which most of our puff-balls belong; probably not less than forty. They may be arranged in two groups. In one group the plants are commonly small, rarely exceeding an inch and a half or two inches in diameter. These, when mature, burst at the top, in a somewhat circular but rather ragged aperture, to permit the spores to escape. The other group, to which generic

importance is sometimes given, is composed of larger plants, which range in diameter from 2 to 12 inches or more, according to the species. These plants when mature rupture irregularly, the commonly thicker rind breaking up in angular and unequal fragments and falling away, thus permitting the spores to be dissipated and scattered by the winds.

Though no deleterious species of puff-ball is known, the flavor of the smaller kinds, so far as I have tried them, is much inferior to that of the larger. Only the latter, therefore, are recommended for food. It is possible, however, that some of the smaller sorts not yet tried, may be well flavored, and may yet be introduced by experimenting mycophagists into the list of edible species.

The Giant puff-ball, *Lycoperdon giganteum*, is the largest species known. Specimens of medium size are 8 to 12 inches in diameter. Smaller and much larger individuals sometimes occur. The largest specimen in the State Museum is about 15 inches in diameter in the dry state. When fresh, it was much

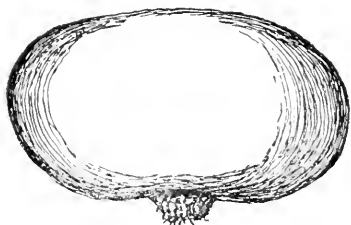

Giant Puff-Ball, *Lycoperdon giganteum*, about one-sixteenth usual size.

larger—probably 20 inches or more in diameter; they shrink greatly in drying. In the larger specimens the vertical diameter is generally less than the horizontal, so that the shape is that of a depressed globe, or a round loaf of bread. The smaller ones are usually less depressed, and are therefore more nearly globular. The color is white,

or whitish, until by age it becomes dingy or somewhat yellowish or brownish. Its surface is nearly or quite smooth, and in growing it rests upon the ground, as it has no stem or stemlike base to support it. When approaching maturity, greenish-yellow stains appear in the previously snow-white flesh. At length the whole interior becomes a soft cottony, but dusty mass of a dingy yellowish brown hue.

This puff-ball grows in fields, pastures and waste places, and by roadsides. It is by no means frequent, though it has a wide range, and has been recorded from New England on the east, to California on the west, and as far south as North Carolina. I know of no reason why it may not occur in every state of the Union. With us it usually appears in August and September.

Its large size, white color and smoothish surface are characters by which it may easily be distinguished from every other species.

The Cup-shaped puff-ball, *Lycoperdon cyathiforme*, is much smaller and much more frequent. It is commonly three to five inches in diameter. It is most often abruptly contracted below into a thick basal part, which gives it a somewhat turbinate shape, but this is not always the case. Its color is somewhat variable, ranging from grayish-white to brown or pinkish-brown. Its surface is smooth, or nearly so, but it usually cracks in an areolate manner, so that the upper half especially presents a system of reticulating chinks enclosing small, more or less angular, darker areas or patches. When mature, the dusty spore mass of the interior presents a purple-brown color.

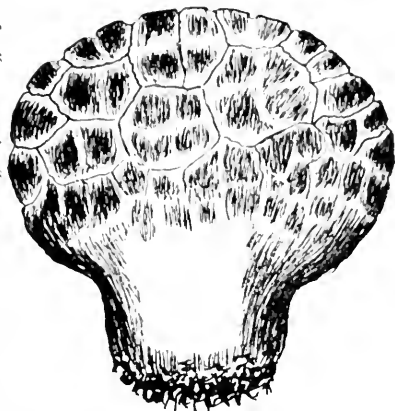

Cup-shaped Puff-Ball, *Lycoperdon cyathiforme*—rather less than half usual size.

After the upper part of the rind has fallen away, and the spores have been dispersed, there remains the basal part of the plant, which is surmounted by the concave or cup-shaped lower portion of the rind. This condition of the plant was the basis for the original description of the species and suggested the name of this puff-ball.

Its place of growth is in fields and pastures, and its range extends westward to the Mississippi River, and south to South Carolina. It appears in August and September, growing singly or in groups of several individuals. Sometimes the old flattened cup-shape base persists till the following spring. It differs from the Giant puff-ball in its smaller size, chinky areolate surface, darker color, and when mature, in its purple-brown interior. Both species are equally good to eat, and both

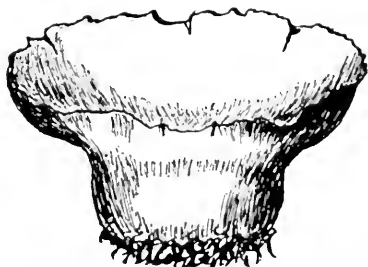

*Lycoperdon cyathiforme*—Cup-Shaped Base of an old plant, about half usual size.

may be prepared for the table in the same manner, as below:

Select immature specimens whose flesh is yet pure white. Peel away the rind and cut the flesh in thin slices, say  $\frac{1}{4}$  to  $\frac{1}{2}$  an inch thick. These slices may simply be fried in butter, and seasoned to taste, or they may first be dipped in a batter made of beaten egg and then fried and seasoned. In this way they make a kind of mushroom omelet or fritters, that is very agreeable to almost all tastes. If preferred, the beaten egg may be thickened with a few bread crumbs or with crushed crackers. Some, who are especially fond of the common mushroom, fry the plain slices in butter, adding a mushroom or two to them to heighten the flavor. A group of the cup-shaped puff-ball or a single large specimen of the Giant puff-ball will furnish sufficient material for a meal for a large family. One correspondent writes me that he once found a Giant puff-ball so large that it afforded a good portion of the dinner of about 50 persons!

There are a few other large species of puff-balls, ranging in diameter from 3 to 8 inches, which grow in some of the southern and western States, and which are probably edible; but a description of which I omit because they have not yet been proved to be good.

There are two puff-balls belonging to the genus *Borista* which have been tested by Prof. William Trelease and pronounced by him to be delicate and excellent. The difference between a *Borista* and a *Lycoperdon* is very slight and need not be discussed here.

The Lead-colored puff-ball, *Borista plumbea*, is about as round as a marble and not very much larger. Its diameter usually varies from half an inch to one inch. It is almost as white as snow when young and in eatable condition. Its thin white coat presently becomes dingy and scales off in flakes, exposing a tougher, thicker rind beneath, which has a dull, dark, but perceptibly leaden hue, that suggests the name. It grows in pastures among short grass, or on naked ground, appearing with us from mid-summer to autumn. Old plants, with an apical aperture for the escape of the spores, may sometimes be found in spring, but they do not much resemble the young edible plant.

The other species, the Ball-shaped puff-ball, *Borista pila*, is very similar to the one just described, in its shape and in the color of the young plant, but it is larger, its diameter being one and a half to two and a half inches. When old, its rind becomes smooth, brown, or slightly purplish-brown, and almost shining.

It is very tough, and opens by an irregular rupture or lacerated aperture. It grows on the ground, either in fields or thin woods, and often persists through the winter in its brown mature condition.

We have two or three species of *Scleroderma* or hard-rind puff-balls, in which the flesh, even in young plants, is not white, but rather of bluish-black or purplish-black. These have not been recorded as edible, and though they are not known to be poisonous, they do not come under the rule given for edible puff-balls, and should be omitted entirely; yet one correspondent reports having eaten them and liking them.

#### IV. MORELS AND HELVELLAS.

These belong to a large class called *Discomyceteae*, "disk fungi." The spores are produced in thin membranous sacks (usually eight in each), imbedded in the flesh of the upper or exterior surface of the cap. This character is not easily seen without a microscope. Comparatively few of the species are large enough and tender enough for food.

Morels are neither like puff-balls nor like mushrooms. They consist of a stem and a cap or head. The cap, which is the spore-bearing part, is either globose, oblong, conical or cylindrical in shape, according to the species. But its most marked feature, and the one by which morels are the most readily distinguished from all other fungi, is found in the small depressions or cavities which occupy its whole exterior surface, giving it a somewhat honey-combed or pitted appearance. The intervening ridges or dissepiments are rather thick and blunt on the edge. In all our species the caps are yellowish, buff or ochraceous when fresh and growing, but they usually assume darker or brownish hues as they mature and begin to dry or decay. The stems are rather stout, hollow, and white or whitish, sometimes tinged with yellow. They are not polished, but slightly roughened by numerous minute branny particles. In some species the stems are often shorter than the head or cap.

The species may be grouped in two sections. In one, the lower margin of the head grows fast to the top of the stem; in the other, it is free from the stem, as in the cap of the common mushroom. In the former case the head is hollow, in the latter there is a cavity beneath it, or rather an open space, between its mar-

gin and the stem. Of the former group, four species occur in New York; of the latter, only two, and these are of very rare occurrence. Their scarcity and their small size make them of comparatively little importance as an article of food.

No morel is known to be poisonous; they can therefore be eaten with considerable confidence, even if the specific distinctions are not well understood. Two or three species of stinkhorn fungi, *Phallus impudicus*, *Phallus duplicatus*, &c., have heads with similar cavities after the spores have been shed, but in these the stems are porous—that is, full of minute pores or cavities—and the head has an apical aperture; and, moreover, the plants have such an intolerable odor that no one would think of eating them. The species of the first group are more common, and the plants themselves are generally of larger size, and it is to this group we must look for our chief supply of morels. To it belong the Common or Esculent morel (*Morchella esculenta*), the Conical morel (*M. conica*), the Narrow-cap morel (*M. angusticeps*), and the Delicious morel (*M. deliciosa*). If any one of these morels is cut through the middle vertically, it will be seen that the head is hollow as well as the stem, and that the cavity is continuous from one to the other.

All the species occur early in the season. Some may be found as early as April, especially in the States south of New Jersey and Pennsylvania. In New York, they are found in May and June. I have never seen one growing here later than June. They occur mostly under trees or in thin, open woods, or along the borders of more dense woods. A favorite habitat is under or near pine trees and ash trees, though it is not impossible to find them under other trees. They are not averse to sandy soil, provided rains are frequent and moisture plentiful.

For the benefit of those who may wish to distinguish the species, the following synopsis is given:

### SPECIES OF MORCHELLA.

Margin of the cap united to the stem,	1.
Margin of the cap not united to the stem,	3.
1. Cap rounded, oval, or nearly so,	<i>M. esculenta</i>
1. Cap conical or oblong-conical,	2.
1. Cap oblong or cylindrical,	<i>M. deliciosa</i>
2. Cap distinctly broader than stem,	<i>M. conica</i>



2. Cap scarcely broader than stem,
3. Cap free from stem to middle,
3. Cap free from stem to top,

*M. angusticeps*  
*M. semilibera*  
*M. bispora*

The Common morel, *Morchella esculenta*, generally has the cap a little longer than broad, so that it is nearly oval in outline. Sometimes it is nearly globular, and occasionally it is slightly narrowed in its upper half, but not so much as to be pointed or conical. The pits or cavities in its surface are more regularly rounded than in the other species, and resemble more the cells of a honey-comb. The cap is much broader than the diameter of the stem. The plants vary from two to four inches in height, but occasionally specimens occur much larger, and sometimes even smaller than these dimensions. The stem is commonly half an inch or more in diameter.

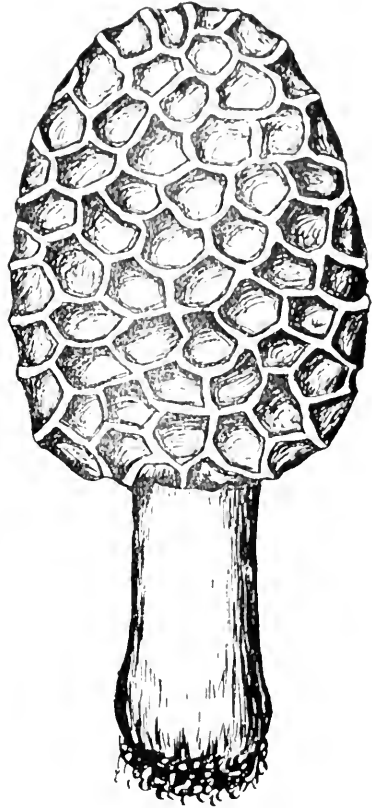

*Morchella esculenta*, full size.

The Conical morel, *M. conica*, is closely related to the preceding species, of which some have considered it a mere variety. It differs from it in having the cap longer in proportion to its width, and also more pointed, so that it is conical or oblong-conical in shape. The principal ridges which separate the rows of pits in the surface appear to run more regularly and distinctly from top to bottom. They are connected by intervening transverse ridges, which are sometimes less elevated than the longitudinal ridges, and therefore the pits often appear longer than broad, and less regular in outline. The cap is decidedly broader than its stem. The plants are generally from three to five inches high.

The Narrow-cap morel, *M. angusticeps*, differs from the

Conical morel in its ordinarily smaller size, its narrowly conical and more acutely pointed cap, which is scarcely broader at its

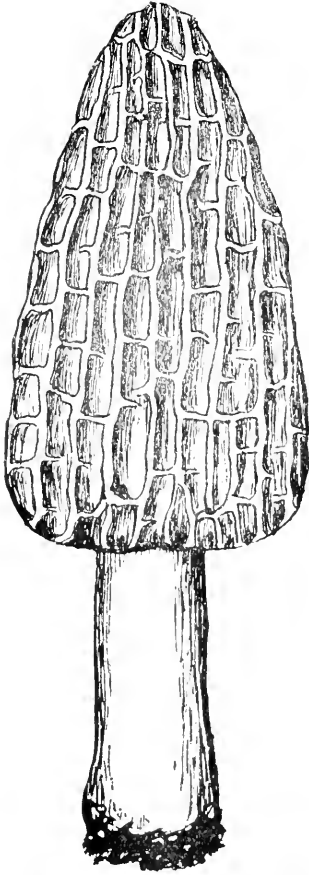

*Morchella conica*, full size

base than the stem which supports it, and in the smaller pits of the cap. The seeming disproportion between the diameter of the stem and its cap gives a kind of deformity to the appearance of the plant, which lack of symmetry is sometimes increased by the cap's being strongly curved. The plant is generally but two to three inches high, but sometimes specimens have been found five or six inches high.

The Delicious morel, *M. deliciosa*, is easily known by its long, narrow cap, which is blunt at the top, and therefore oblong or cylindrical in shape. Occasionally, it is a little more narrow in its upper half, but even then it is not as sharply pointed as in the Narrow-cap morel, nor is the disproportion between the diameter of the cap and the stem so great. As in that species, the pits in the surface of the cap are small and narrow, and usually longer than broad. It also is generally

but two or three inches high. In this part of the country it is less common than either of the preceding species.

The Half-free morel, *M. semilibera* (by some called the Hybrid morel, *M. hybrida*), and the Two-spored morel, *M. bispora*, are of such rare occurrence that it is scarcely worth while to give here a detailed description of them. Their essential characters can be learned from the analytical table.

Some writers speak highly of the edible qualities of morels;

others are less enthusiastic. My own experience would lead me to say that they are not, as a rule, very highly flavored, though better than some fungi that are recorded as edible. The name of the "Delicious" morel implies excellent flavor, but it has not been my fortune to give it fair trial. One correspondent says: "I do not think much of morels; if cooked like mushrooms, they become tough." Herein, perhaps, is one cause of dissatisfaction with them—they may be spoiled by bad cooking. Some fungi are made more tough by too severe cooking; it is better to let such kinds simmer slowly over a gentle fire. One of the published receipts for cooking morels says: "Cut in halves the clean morels, place in a stewpan with butter, and set over a clear fire. When the butter is melted, add a little lemon juice, salt and pepper. Then *cook slowly for an hour*, adding from time to time small quantities of beef gravy.

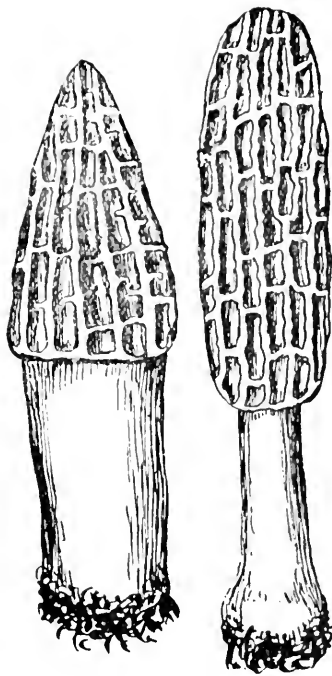

*M. angusticeps.*

*M. delioiosa.*

Cordier says that the Common morel is a delicate food, and one that is in general demand. Cooke speaks of morels in general as about the safest and most delicious of edible fungi. There is one thing in their favor—either because they appear so early in the season or for some other reason, they are seldom infested by the larvæ of insects. On this account their natural flavor is unimpaired, and there is little loss from damaged specimens. The flesh is rather fragile and not very watery. They are easily dried, and in this way may be kept for future use.

## V. THE HELVELLAS.

The Helvellas are closely related, botanically, to the morels. In them the cap is not pitted, as in the morels; yet it is by no means even or symmetrical. It is more or less lobed, reflexed or variously folded, and the stem in some species is furrowed longitudinally with continuous or interrupted grooves. The color of the cap also varies more in the different species, and the plants themselves are mostly of smaller size, and with few exceptions are of rarer occurrence. They chiefly occur in woods or on their borders, and should not be sought in cleared fields.

The largest and most common species with us is the Edible helvella, or, as it is sometimes called, the Esculent gyromitra, *Gyromitra esculenta*. The original botanical name was *Helvella*



Esculent Helvella, somewhat reduced.

*esculenta*. This fungus may be known by its bay-red, or chestnut-red irregular cap, with its brain-like convolutions or irregular foldings, inflations and depressions. The general form of the cap is rounded, and the lower margin is attached to the stem in two or three places. There are sometimes paler or yellowish tinted patches on the cap, and with advanced age, or in drying, it assumes darker or brownish hues. The stem is whitish and scurfy, and often enlarged or swollen at the base. When mature it is hollow. It is frequently deformed or irregular. The

plant is commonly two to four inches high, with the cap two to three inches broad, and the stem one-half to one inch thick. Specimens are sometimes large enough to weigh a pound each.

They appear in this latitude in May and June. I have never

seen it growing here later than June. It is especially fond of light, sandy soil, under, or in the vicinity of pine trees, but it requires considerable moisture, and it is to be sought in rainy weather, or in wet, springy places.

The French author, Cordier, says that it has an agreeable taste, and is highly esteemed, and that it is sold in Germany as a true morel. Though I have repeatedly eaten it without experiencing evil consequences, its flavor to me is not that of a first-class mushroom. But then it was simply fried in butter and seasoned; perhaps with more elaborate preparation it might be better flavored. Care should be taken by those eating it to use it with moderation, and not to keep it too long before cooking. Sickness has been known to result from eating freely of a quantity of it which had been kept twenty-four hours.

Of the remaining helvellas that have been used for food when they could be procured in sufficient quantity, the White helvella, *H. crispa*, differs from all the others in its color, which is white, both in its cap and stem. It, and all our other species, are smaller than the Edible helvella, and they are more scarce and only found in the woods. They are also later in the time of their appearance, occurring from midsummer to autumn. They are reputed to be excellent eating, and all similar in flavor, but from their scarcity and small size it is hardly worth while to give a detailed description of each. For the benefit of those who may wish to identify them, should they be fortunate enough to meet with them, their names and the following analytical table are given. Their names are—White helvella, *H. crispa*; Cinereous or Black-top helvella, *H. lacunosa*; Sulcate helvella, *H. sulcata*; Mitre-shaped helvella, *H. infula*; and the Elastic helvella, *H. elastica*.

#### ANALYTICAL TABLE.

Stems furrowed lengthwise,	1.
Stems not furrowed,	3.
1. Plant wholly white,	<i>H. crispa</i> .
1. Plant not white or only part white,	2.
2. Stem interruptedly furrowed,	<i>H. lacunosa</i> .
2. Furrows of the stem not interrupted,	<i>H. sulcata</i> .
3. Stem short, stout; cap mitre-shaped,	<i>H. infula</i> .
3. Stem long, slender; cap not mitre-shaped,	<i>H. elastica</i> .

The irregular mitrula, *Mitrula ritellina* var. *irregularis*, and several of the larger species of Cup-fungi (*Pezizas*), belong to this class, and are known to be edible, but because of their scarcity and small size, further notice of them is omitted.

## VI. THE HYMENOMYCETÆ.

The mushrooms to be noticed in this and succeeding articles belong to a very large class of fungi known to botanists as *Hymenomyceeteæ*, a word composed of two parts, signifying "membrane fungi," and indicating that the spores are produced on thin or membranous parts or surfaces. In the common mushrooms, and in all others of similar structure, these spore-producing membranes are found on the under surface of the cap. They consist of thin lamellæ or leaves, which are attached by their upper edge to the cap, and which extend in a radiating manner from the stem to the margin of the cap. That space may not be wasted, shorter ones usually intervene between the longer, especially toward the margin of the cap. In a few species in which the stem is attached to the side of the cap, or in which the stem is wholly wanting, the cap being attached to its place of growth by some point or part of its margin, the lamellæ, which are often called "gills," radiate from this point of attachment, or from the lateral stem to the other parts of the circumference of the cap. All species of Hymenomyceeteæ that have these radiating lamellæ constitute a great family called *Agaricineæ*.

There is another group of species in which the under surface of the cap is full of small holes or pores—in some large enough to be easily seen, in others so small as to be scarcely visible to the naked eye. These pores are closely crowded together, and in them the spores of the fungus are produced. They take the place of the lamellæ in the Agaricineæ, and may be supposed to be formed by radiating lamellæ, connected by innumerable transverse partitions. All species that have them are grouped under the general name *Poly-poreæ*.

In a third group the under surface of the cap has neither lamellæ nor pores, but in their place are numerous awl-shaped pendant teeth or spines. The spores are produced on the surface of these teeth. Theoretically, these teeth may be supposed to be formed by the regular and fine gnashing of lamellæ, but they are not arranged in radiating rows, as they would be if actually formed in this way. Those species which have these spine-like teeth constitute the group *Hydneæ*. In one edible species of

this group the cap itself is replaced by numerous branches, which bear the spine-like teeth on their lower surface.

These three subdivisions or groups include by far the greater part of our edible mushrooms. Familiarity with their distinguishing features is therefore very important.

There are three groups remaining, in each of which there are a few edible species, but they are not usually considered of much importance. In them the spores are produced directly upon some exposed part of the surface of the fungus, without the intervention of lamellæ, pores, or spines. A symmetrical cap and stem are often absent. In one group the substance is tremelloid or gelatinous. By the aid of the following analytical table, our edible species may be assigned to their respective groups:

FAMILIES OF HYMENOMYCETEE.

- |   |                      |
|---|----------------------|
| Cap present,  | 1.                   |
| Cap wanting,  | 2.                   |
| 1. Cap with radiating lamellæ beneath,                              | <i>Agaricineae.</i>  |
| 1. Cap with pores beneath,  | <i>Polyporeae.</i>   |
| 1. Cap or branches with spine-like teeth beneath,                   | <i>Hydneae.</i>      |
| 1. Cap with under or spore-bearing surface even,                    | <i>Thelephoreae.</i> |
| 2. Plant club-shaped and simple, or bush-like and branched; fleshy, | <i>Clavariaceae.</i> |
| 2. Plant irregularly expanded; gelatinous,                          | <i>Tremellineae.</i> |

The *Agaricineae*, or "agarics," probably include more edible species than either of the other families. For the sake of convenience in the identification of the species, systematists have divided them into smaller groups, depending on the color of the spores. We cannot do better than to follow this arrangement in studying the species. It is not a difficult matter to ascertain the color of the spores. Generally they are colored nearly or quite like the lamellæ of the mature plant, but to this there are many exceptions, and to be exact, we must see the spores themselves. To do this with the naked eye, they should be collected in a mass, for they are so minute that singly they are invisible without the aid of a microscope. To do this, cut the cap of a fresh, sound, fully-developed mushroom from its stem and place it in its natural position, gills downward, on a piece of white paper, at least as broad as the cap. In a short time, say two or three hours, it will generally drop enough spores on the paper to show their color on removing the cap. If the spores are white—and we may infer that they are so if the mature lamellæ are white—white paper will not be so good for disclosing their color as paper of some darker hue. Sometimes, therefore, the cap is placed on

a piece of black paper when the spores are suspected of being white. Or it may be placed on a piece of glass, and after the spores have been dropped and the cap removed, the glass may be placed over a white or a black background, as the circumstances may require. To prevent too rapid drying of the cap, and to shut out currents of air, a goblet or similar vessel may be inverted over the cap while it is dropping its spores.

Having ascertained the color of the spores, the following table will show in which section the species belong:

SECTIONS OF AGARICINEÆ.

Spores brown, purplish-brown or black,	<i>Melanosporae.</i>
Spores ochraceous or rusty-ochraceous,	<i>Ochrosporae.</i>
Spores rosy or pinkish,	<i>Rhodosporae.</i>
Spores white, whitish or pale yellow,	<i>Leucosporae.</i>

Our edible species of the first section, *Melanosporae*, are found in three genera—*Agaricus*, *Hypholoma* and *Coprinus*. In the genus *Agaricus*, the gills are not attached to the stem; the stem, near its top, is surrounded by a membranous ring or collar, and the spores, in our edible species, are brown.

In the genus *Hypholoma*, the gills are attached to the stem; the stem has no collar, and in the single edible species the spores are purplish-brown.

In the genus *Coprinus*, the gills, when mature, dissolve into an inky fluid, and in our edible species the stem has no collar at all, or only an evanescent one, and the spores are black, or nearly so. Because of the melting of the gills into a black fluid, these plants are called “inky fungi.” As in the case of puff-balls, they are fit for food only in the young or immature state, and as they mature rapidly, great promptness is necessary if we would utilize them.

In the early days of mycology nearly all fungi having gills were included in the genus *Agaricus*. At present, however, it is limited to those species that have brown spores, free gills and a stem bearing a ring or collar. These characters are found in the common mushroom whose botanical name is *Agaricus campester*. (This is commonly written *Agaricus campestris*, but the more classical and more grammatical form is used in Saccardo’s *Sylloge*, and it is adopted here.) There are several edible species belonging to this genus, and indeed no dangerously poisonous species is known in it. These species are very closely related to each other, and perhaps there is no simpler way of expressing their distinctive characters than by an analytical table. They may be arranged in two groups depending on their place of



growth. This arrangement is not as rigidly exact as would be desirable, but it throws those species together that are most closely related to each other, and is therefore natural.

The essential characters to be noted in all the species in this genus are, gills free from the stem, pink colored before maturity, blackish-brown or black when fully mature, spores brown, and a stem bearing a ring or collar. There are many similar mushrooms which are not known to be edible but which have pink gills. Their gills, however, never become brown or blackish-brown; their spores are pink, and their stem never has a collar.

## VII. THE COMMON MUSHROOM—ITS RELATIVES.

### ANALYTICAL TABLE OF AGARICUS.

- |   |                            |
|---|----------------------------|
| Plants growing in pastures or open places,                            | 1.                         |
| Plants growing in woods and groves or their borders,                  | 4.                         |
| 1. Stem stuffed or solid,   | 2.                         |
| 1. Stem hollow,   | 3.                         |
| 2. Gills at first pinkish, about as wide as the thickness of the cap, | <i>A. campester.</i>       |
| 2. Gills at first whitish, narrower than the thickness of the cap,    | <i>A. rodmani.</i>         |
| 3. The collar radiately tomentose on the lower surface,               | <i>A. arvensis.</i>        |
| 3. The collar evenly flocculose on the lower surface,                 | <i>A. subrufescens.</i>    |
| 4. The flesh quickly changing to dull red where cut or broken,        | <i>A. hemorrhoidarius.</i> |
| 4. The flesh not changing to red where cut or broken,                 | 5.                         |
| 5. Cap white, silky or smooth,  | <i>A. silvicola.</i>       |
| 5. Cap brownish, or if white not smooth,                              | 6.                         |
| 6. Cap with numerous minute persistent brown scales,                  | <i>A. placomyces.</i>      |
| 6. Cap merely fibrillose, or with few evanescent scales,              | <i>A. silvaticus.</i>      |

The Common mushroom, sometimes called the Edible mushroom, as if it were the only edible species, is perhaps more generally and better known than any other. It is the one commonly cultivated and most often seen on the tables of the wealthy and of public houses. It is so eagerly sought in some of our cities that it is difficult to find wild specimens in the vicinity of these towns. They are gathered almost as soon as they appear.

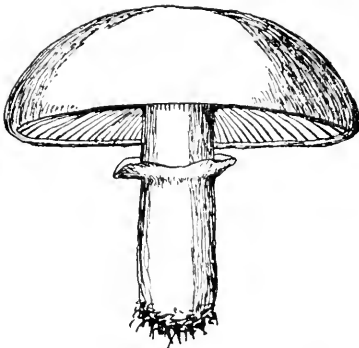

Common Mushroom, *Agaricus campester.*

In very young plants the cap is somewhat globular or hemispherical, and the gills are concealed by the membrane or

veil which stretches across from the stem to the margin of the cap. These young plants are called "button mushrooms." As the plant develops and the cap expands, the edge of the veil separates from the margin of the cap, but still adheres to the stem, and forms the ring or collar. The cap, when fully expanded, is broadly convex, or nearly flat above. It is generally adorned with silky fibrils, but sometimes these are collected in such a way as to form little bundles or scales, which, however, are usually scarcely noticeable. In old age they have often vanished, and the cap appears quite smooth. Its margin generally extends slightly beyond the outer extremity of the gills.

The color of the cap varies from pure white to brown or tawny brown. The flesh is white. The gills, when first revealed by the separation of the veil, are of a delicate pale pink hue, but with advancing age this gradually deepens, and finally turns to a dark brown or blackish-brown color. In dried specimens the color might easily be called black.

The stem is rather short—scarcely as long as the cap is broad. It is nearly cylindrical, *i. e.*, about as thick at the top as at the bottom, and its color is white or whitish. The substance in the centre is a little softer or more spongy than toward the exterior, and for this reason the stem is described as "stuffed," as if it were filled with a pith. Sometimes the collar shrivels so much that it is scarcely perceptible in old plants, or it may even disappear entirely. The spores are brown in the mass. They are sometimes described as purplish-brown, but I never could detect any purplish tint in them or in the gills.

This mushroom, like many other plants that have been long and extensively cultivated, has developed into several varieties, which exhibit quite well marked distinctive features.

The White variety, var. *albus*, has the cap and stem white, the cap silky and the stem short. This is our most common wild form, and it is also cultivated.

The Gray variety, var. *griseus*, has the cap gray, silky and shining. I have seen this from Virginia only.

The Garden variety, var. *hortensis*, has the cap brownish, or almost tawny brown, and fibrillose, or marked with obscure scales. This variety is often cultivated, but rarely found wild.

Several other varieties are recorded as European, but I have seen none of them in this country.

Generally the cap of the Common mushroom is two to four inches broad, the stem one to three inches long, and one-third to two-thirds of an inch thick. Its most frequent place of growth is

in rich pastures, where the grass is kept short, or in similar waste places. Its time of appearance is late summer and autumn. It will scarcely be found in this latitude before the middle of August, though it is said sometimes to appear in spring. I suspect that in such cases the next species has been mistaken for it. I have never found it growing in thick woods.

Almost every cook knows how to prepare this mushroom for the table, and many receipts for cooking it are given in cook books. No extended directions are therefore necessary here. One of the simplest methods, and one which may be employed in cooking this and many other tender species, is to fry gently in butter, seasoning according to taste. They may be stewed in milk or cream, or broiled on a gridiron, or baked in an oven, as preferred. To some tastes they are very acceptable when eaten raw. Dr. Cooke says: "When abroad on a day's excursion, one or two of these raw specimens are an excellent substitute for sandwiches, as they satisfy hunger, are nutritive and digestible, and very pleasant and grateful to the palate."

Rodman's mushroom, *Agaricus rodmani*, may easily be mistaken for the Common mushroom unless attention is given to its distinctive features. Its cap is more firm, and somewhat ochraceous or rusty yellow on the disk or centre; the very young gills are whitish, but they soon assume the ordinary pinkish hue, and they are narrower in proportion to thickness of the flesh of the cap. The stem is very short and solid, and the collar, when well developed, exhibits a striking character. It appears as if there were two collars, or a double collar, with a space or groove between them. This character

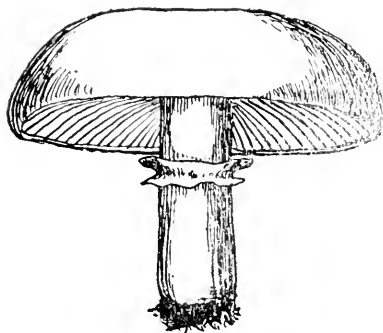

Rodman's Mushroom.

is not always clearly shown, but in its absence the other distinctive features will serve to distinguish the species.

It grows in grassy grounds, and even in crevices of unused pavements or paved gutters in cities. It appears from May to July. I have not found it in autumn, when the Common mushroom is to be found, nor have I ever been able to get it in sufficient quantity to prove its edible qualities; but Mr. G. Rod-

man, who first collected it, and furnished the first specimens seen by me, tested it, and on his experiment it is classed as edible. I would not hesitate to eat it if I could get fresh specimens.

The Field mushroom, also called the Horse mushroom and Meadow mushroom, *Agaricus arvensis*, has by some been considered a mere variety of the Common mushroom. But it differs in some respects, and is generally kept as a distinct species in the descriptive manuals. It generally exceeds the Common mushroom in size, and when old or in drying, the cap, which is usually white, is apt to assume yellowish hues which do not pertain to the other species. The gills, when first exposed, are often whitish, the stem is hollow, and frequently somewhat thickened at the base, and the collar is thicker and appears as if composed of two parts closely applied to each other and making a double membrane, the lower of which is radiately or stellately split and tinged with yellow. The flavor is by some considered inferior to that of the Common mushroom, but on this point tastes seem to differ. Persoon considered it superior to the Common mushroom both in flavor and digestibility, and Vittadini says it is very delicate and easy of digestion, but has a stronger odor than the Common mushroom. "Very sapid and very nutritious;" "flavor anise-like and very agreeable;" "edible and of exquisite flavor;" "delicious when young, but tough when old," are some of the opinions concerning it as expressed by various writers.

It grows in cultivated fields, grassy pastures, and waste places. Occasionally it is found under trees, and even within the borders of woods. It has been asserted that its spores must pass through the alimentary canal of some animal, or else they will not germinate. However much or little of truth there may be in such a statement, it is common enough to find this mushroom growing in places where no trace of the dung of animals can be seen. It may be found here from July to September.



Field Mushroom.

A beautiful white mushroom, closely resembling the Field

mushroom, occurs in the borders of woods or in open places in thin woods. It differs from the Field mushroom in its thinner cap, its longer stem, and in having an abrupt flattened bulb at the base of the stem. Its collar generally resembles exactly the collar of the Field mushroom, but plants sometimes occur in which it appears to be a single lacerated membrane. For this reason the plant has sometimes been referred to the Wood-Inhabiting mushroom, *Agaricus silvicola*. But its affinities appear to me to connect it more closely with the Field mushroom, and I prefer to regard it as a variety of that species, and give it the name Abrupt variety, var. *abruptus*, in allusion to the peculiar character of the bulb. It occurs in summer and autumn. I have eaten it and know it to be edible.

The Slightly Reddish mushroom, *Agaricus subrufescens*, when compared with the Common mushroom, will be found to differ in its thinner cap, in the very young gills being whitish, in its longer hollow stem, which is frequently thickened or somewhat bulbous at the base, in its collar which is sprinkled with minute flocculent tufts beneath, and in the slender branching strings of its mycelium. It is quite as large as the Common mushroom. The color of the cap varies from whitish to gray or dull reddish-brown, and the color of the gills passes from whitish to pinkish, and finally to blackish-brown. It has been successfully cultivated, and was found by Mr. W. Falconer in a wild state, growing on a compost heap composed chiefly of leaf mold. It is manifestly a rare species, but probably a valuable one, because of its capabilities as a cultivated species. It may be cultivated through the summer months, when the cultivation of the Common mushroom often ceases to be profitable because of high temperature and the attacks of insects. It was found wild in autumn.

While approaching slightly the European Reddish variety of the Common mushroom, *A. campester* var. *rufescens*, in the slight reddish tints sometimes seen on its cap, it at once and decidedly differs from that plant in its flesh, which does not assume a red color when cut or broken.

The Bleeding mushroom, *Agaricus hemorrhoidarius*, is easily known by the character which has suggested its name. When its flesh is cut or broken, the part thus exposed promptly assumes a dull red color, as if blood were about to issue from the wound. Mere bruises of the cap, stem, or gills often cause this change of color. This also is a very rare species. In all my collecting, I have met with it but once. It is also a very uninviting

mushroom, of a dingy brown color, by reason of which it is easily overlooked. Its gills have at first the pink hue of the other species of this group, changing to blackish-brown with age. It grows under trees in woods, and like other species with a similar habitat, its stem is rather long and often swollen or sub-bulbous at the base. I have not eaten it, but it is said to be of excellent quality.

The Wood-inhabiting mushroom, *Agaricus silvicola*, is so closely related to the Common mushroom that it has been considered by some good mycologists to be a mere variety of it. Its chief differences are in its place of growth, its longer and comparatively more slender stuffed or hollow and somewhat bulbous stem. In other respects it agrees closely with the white or whitish forms of that species. For edible purposes, it is not very important whether it is considered a species or a variety. But growing in the woods, it is of the utmost importance that it should not be confused with white forms of the poisonous Amanitas which grow in similar localities, and which are easily separated by reason of the persistently white color of their gills.

The Flat-cap mushroom, *Agaricus placomyces*, is one of our prettiest species. Its cap is rather thin, at first convex, but when fully expanded, it is quite flat. Its ground color is whitish or grayish, but it is everywhere adorned with very small distinct brown persistent scales, except on the disk, where they are so compacted as to give that part a brown color. In old age or in dried specimens, the whole cap is apt to become brown. The gills, as in several other species of this genus, are at first white, then pink, and finally blackish-brown. Its stem is rather long and slender, stuffed with a cottony pith and bulbous at the base. It is commonly whitish, but sometimes bears yellowish stains toward the base.

It grows under trees or in the borders of woods, and is found in summer and aut-



Flat-Cap Mushroom. Two-thirds size.

umn. It is not plentiful here and I have never eaten it, but a correspondent who has been more fortunate in finding it pronounces it "very good eating."

The Wood mushroom, or Silvan mushroom, *Agaricus silvaticus*, is also a scarce species with us. It is similar in size and shape to the Flat cap mushroom, but it is of a more brownish color, with the cap more prominent in the centre, and adorned merely with fibrils or with a few obscure scales, which at length disappear. Its gills also are pinkish at first, and then blackish-brown as in the other species.

It occurs in summer and autumn in woods as its name indicates, but it is neither frequent nor abundant, and of but little importance as an edible species.

The term "Brown mushrooms" has been applied indiscriminately by one writer to such species as the Bleeding mushroom, the Flat-cap mushroom and the Silvan mushroom.

## VIII. PURPLISH-BROWN AND BLACK SPORES.

The genus *Hypholoma* differs from *Agaricus* in having the gills attached or grown fast to the stem at their inner extremity and in having a stem destitute of a collar. Its species have not, previous to this time, been regarded as edible. But one of my correspondents has eaten freely and repeatedly of the Perplexing mushroom, *H. perplexum*, and he reports it has no bad taste and produces no ill effects, and on the strength of this it is here admitted among the edible species.



*Hypholoma perplexum*, slightly reduced.

It usually grows in clusters of few or many individuals, on or about stumps, or at the base of trees in woods or in open places. It is found in autumn. The cap is from one to



three inches broad, yellowish on the margin, and red or brownish-red in the centre. The flesh is white, and has a mild taste. The gills are at first pale yellow, but soon this color is tinged with green, and when mature they are purplish-brown. The stem is rather slender, commonly two to three or three and a half inches long, and two to four lines thick. It is yellow above, but more or less reddish or rusty-red toward the base. It is distinctly hollow, even in young specimens. The pores are purplish-brown, and often they are produced in such quantity that the caps of the lower specimens in a cluster are badly soiled and stained by them.

This species is so closely related to the Brick-red mushroom, *H. sublateritium*, that by its external characters it is not easily separated from it. Indeed, it is so closely allied to it that it may easily be regarded as a mere variety of it. The typical form of the Brick-red mushroom may be known by its bitter taste and its stuffed stem. In color it is almost the same as the Perplexing mushroom, except in its gills. Our species is also closely related to the Gray-gilled mushroom, *H. epixanthum*, and to the Tufted Yellow mushroom, *H. fasciculare*. The perplexing thing about it is that it combines the characters of these three species. It has the cap colored like the Brick-red mushroom, it has the mild taste of the Gray-gilled mushroom and the greenish tint to the immature gills, which is seen in the Tufted Yellow mushroom. It is very abundant in some hilly and mountainous districts, and it continues to appear until its growth is stopped by cold, freezing weather.

The genus *Coprinus* is one easily recognized. Many of the species grow on dung, as the name implies, but some grow on the ground, and others on decaying wood. Most of the plants are very short-lived, and some of them literally grow up in a night and decay in a day. The gills in all of them deliquesce when mature and form a black ink-like liquid which has suggested for these plants the name "Inky fungi." The spores are black, with few exceptions, and consequently the color of the mature gills as well as of the liquid they form is black. Most of the plants are of such small size, and of such an ephemeral existence, that they are of little value as food. Even the larger and more durable kinds have very thin caps, and must be gathered and cooked with promptitude. They should be used before the gills turn black, or they will make a repulsive looking dish. They are not generally credited with possessing a high flavor, but they are among the most tender and digestible of all mush-

rooms, and one correspondent affirms that their flavor may be greatly improved by cooking one or two caps of the common mushroom with them. They are often utilized in the manufacture of catsup.

Three species may be classed as edible. They are recognizable by the color of the caps.

Cap white or whitish,

*C. comatus.*

Cap gray or grayish-brown,

*C. atramentarius.*

Cap ochraceous or reddish-ochraceous,

*C. micaceus.*

The Shaggy coprinus or "Maned agaric," *Coprinus comatus*, has the cap, when young, oblong or cylindrical. It is then much longer than broad, but it expands with age. Its general color is

white or whitish, but it is adorned with fibrillose scales which are slightly colored, usually of a yellowish hue, and at the top is a yellowish, smooth surface, as if covered with a cuticle. The gills are at first very closely packed side by side and white, but with advancing age they separate and pinkish or purplish tints appear, soon to change to black. The stem is white and hollow. In the young plant, it has a collar close to the appressed margin of the cap. It is slightly adherent or movable, and has generally disappeared by the time the plant is mature. The cap is one and a half to three inches long before expansion, and the stem is three to five inches long. The plant is fragile and easily broken. It grows in rich, loose earth by roadsides, in pastures or waste places, and on dumping grounds about

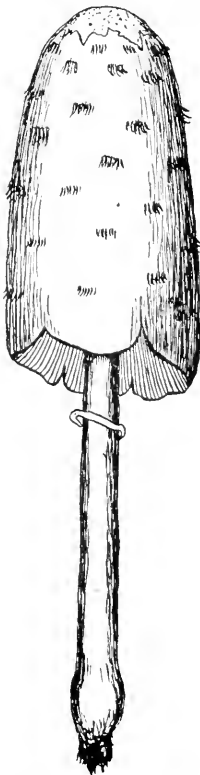

*Coprinus comatus*, two-thirds size.

cities. It appears in autumn and may sometimes be found quite late in the season.

"When young, it is very sapid and delicate;" "cooked quickly

in butter with pepper and salt it is excellent;" "edible, tender and delicious;" "in flavor it resembles the Common mushroom, to which it is quite equal, if not superior: it is clearly more digestible and less likely to disagree with persons of delicate constitutions," are opinions recorded in its favor.

The Inky coprinus, *C. atramentarius*, has a gray or grayish-brown smooth cap, except that sometimes there is a slight scaly appearance on its centre or disk. It is often irregular on the margin. When young it is somewhat egg-shaped. The gills are at first crowded and whitish, or grayish, but they soon become brown and begin to deliquesce. The stem is smooth, hollow and white. It sometimes has a slight vestige of a collar near its base when young, but all traces of it soon disappear. It grows in clusters in gardens and waste places, appearing in autumn. The black fluid of its dissolving gills has sometimes been employed as a poor substitute for ink.

A form is often found in woods in the latter part of summer, which is smaller, but more regular and beautiful than that growing in the open country. It is the Wood variety, var. *silvestris*.

The Glistening coprinus, *C. micaceus*, is a small, but common and pretty species. Its cap is thin, generally conical or bell-shaped, and marked with numerous striations, or parallel longitudinal impressed lines which extend from the margin half way or more toward the top or centre. The centre is even, and often a little more highly colored than the rest. In the young plant, especially, the cap is often sprinkled with shining atoms, which have suggested the name, but these are not very noticeable, and they are frequently absent. The color is variable, and ranges from buff to ochraceous, reddish ochraceous, or tawny yellow. It often becomes sordid or brownish in old age, or in wet weather.

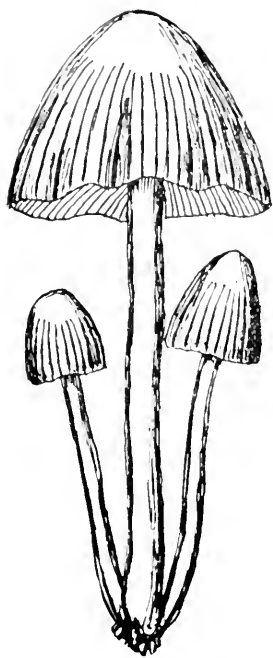

*Coprinus micaceus*, natural size.

The gills are at first whitish, but they become brown or black with age. The stem is slender, hollow and white. The spores are dark-brown, but not truly black, as in the other species mentioned above. The cap is commonly about one inch broad—sometimes two; the stem is one to three inches long, and scarcely thicker than a common pipestem. The plants grow in clusters from decaying wood, or on the ground. When they appear to grow from the ground, it is probable that some decaying root or piece of wood lies buried beneath them. It may often be found growing from the margin of sidewalks in our cities, where shade trees have been cut down. The decaying roots or stumps of these trees afford a suitable habitat for this fungus, and often successive crops appear at intervals in the same spot from May to November. Whenever the temperature and the degree of moisture is suitable, they grow. Indeed, they are a kind of barometer, and sometimes presage rain. I have repeatedly noticed their yellowish clusters beginning to appear a day or two before a rain-storm. If the weather is very warm and the air dry, a cluster may be young and fresh in the morning, and old and withered in the afternoon.

European writers do not class this among the edible species, probably because of its small size. But it compensates in numbers for its lack of size, and it has the advantage of being easily and frequently procurable. In tenderness and delicacy it does not seem to me inferior to the shaggy coprinus, and it certainly is harmless, for I have repeatedly eaten it with no ill results.

## IX.— OCHRACEOUS AND PINK SPORES.

Of the species belonging to the section *Ochrosporae*, only two or three have been tested by myself or my correspondents, and although several others have been recorded as edible, it is my purpose to describe those only that have been proved by us. Edible species belonging to the genera *Pholiota*, *Parvillus* and *Cortinarius* have been recorded. The few which we will notice belong to *Cortinarius*.

This is a genus containing many species, of which several will probably be found upon trial to be esculent. Eight have been classed as edible in Europe, and three in the United States. The species of *Cortinarius* are distinguished from other Agaricineæ by their rusty-ochraceous spores, and by the webby filaments that stretch from the stem to the margin of the cap in the young plant. These filaments disappear in the mature plant, and therefore the collar is absent from the stem in species of *Cortinarius*, though sometimes a few filaments adhere to the stem, and by the lodgment of the falling spores upon them, a rusty-brownish stain is occasionally seen about the stem instead of a collar. The mature gills in nearly or quite all the species are dusted by, and correspond to the spores in color, but in the young plants the color is almost always quite different. It is, therefore, very important to know the color of the gills in the young plant in order to identify the species of this genus. The gills are attached to the stem in all the species.

The Violet cortinarius, *C. violaceus*, is a beautiful mushroom, and one of the most easily recognized species of the genus. The whole plant, when young, is of a dark violaceous color without and within. The cap is usually well formed and beautifully adorned with numerous minute hairy tufts or scales. The gills are at first of the same color, but when old they become dusted with the spores, and have their color modified accordingly. The stem is rather long and more or less bulbous or thickened at the base. The cap is generally two to four inches broad, and the

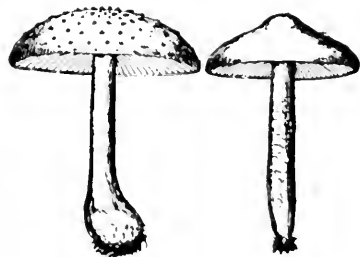

*Cortinarius violaceus*, *C. collinitus*.

stem three to five inches long, and a half inch or more thick. It grows in woods in hilly or mountainous districts, and may be found from July to September. It is solitary or scattered in its mode of growth, and not very plentiful. It retains its color somewhat when cooked, and in consequence, the dish of Violet mushrooms is scarcely as attractive to the eyes as it is to the palate.

The Smear'd cortinari'us, *C. collinitus*, is much more common than the preceding species, and has a much wider range. As its name indicates, both cap and stem are covered with a viscid slime or gluten, which makes it disagreeable, or at least unpleasant, to handle. The cap is yellow, tawny-yellow, or somewhat ochraceous in color, and when the gluten on it has dried, it is very smooth and shining. The flesh is white or whitish. The gills are at first of a grayish or bluish-white hue, sometimes called clay-colored, but when mature they are rusty-ochraceous or cinnamon color. The stem is straight, solid, cylindrical, and generally a little paler than the cap. When the gluten on it dries, it cracks transversely, giving the stem a peculiar, scaly appearance.

The plant is two to five inches high, with a cap commonly one and a half to three inches broad. The stem is one-fourth to one-half an inch thick. It grows in thin woods, copses and partly-cleared lands, and may be found here from August to October.

It is well to peel the caps before cooking them. The gluten often causes dirt and rubbish to adhere to them very tenaciously.

The Cinnamon cortinari'us, *C. cinnamomeus*, is a smaller species than either of the preceding, but much more plentiful. Its cap is usually one to two inches broad, its stem one to three inches long and about one-fourth of an inch thick, or a little less. Its cap may be convex, plane, or furnished with a central prominence or umbo. When young, at least, it is coated with silky or hairy fibrils, and these sometimes are distinctly visible even in the mature plant. Its color is quite variable, but always some shade of yellowish brown

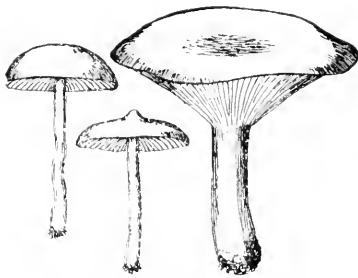

*Cortinari'us cinnamomeus.* *Clitopilus prunulus.*

or cinnamon. This has suggested the name. The flesh is yellowish. The gills also are very variable in color, but in the young plant they are some shade of yellow, tawny, or ochraceous, ex-

cept in the Half-red variety, *Cortinarius cinnamomeus* var. *semisanguineus*, in which they are of a dark blood-red color before the spores are developed. The stem is rather slender, stuffed or hollow, fibrillose, and similar in color to the cap.

The plant grows in woods or along their borders, under trees, or in mossy swamps. Like many flowering plants which have a wide range and are not particular as to their habitat, this mushroom is perplexing because of its variability; but the characters given above will enable it to be recognized. It often emits a slight odor of radishes.

The Red-zoned cortinarius, *Cortinarius armillatus*, and the Chestnut cortinarius, *Cortinarius castaneus*, are both considered edible, and both occur in this country, but not having proved them, descriptions will be omitted. For the same reason the Involute paxillus, *Paxillus involutus*, is omitted. To these we might add also the Early or Spring pholiota, *Pholiota praecox*, the Scaly pholiota, *Pholiota squamosa*, and the Changeable pholiota, *Pholiota mutabilis*.

In the section *Rhodosporae*, sometimes called *Hyporhodii*, the spores and the mature gills are rosy or pinkish-colored. Only a few species are known to be edible, and some are thought to be injurious or unwholesome. Two species, belonging to the genus *Clitopilus*, are here introduced. This genus is separated from all others of this section by its fleshy stem, and by the peculiar attachment of the gills to the stem. They are gradually narrowed at their inner extremity and run down upon it.

The Plum clitopilus or Plum mushroom, *Clitopilus prunulus*, has a fleshy, compact, broadly convex, or nearly plane cap, which is white or whitish, but sometimes a little clouded in the centre, and often suffused with a kind of bloom which, from its resemblance to the bloom of a plum, is supposed to have suggested the name of the fungus. The margin of the cap is sometimes wavy or irregular. The gills are white when quite young, but they soon assume a pinkish or salmon color, like that of the spores. The stem is solid, white, and usually rather short. The flesh is white, and the plant has a distinct farinaceous or meal-like odor and taste. The cap is commonly two to three inches broad, the stem one to three inches long, and a half inch or less in thickness.

The plant is found in woods and open places in warm, wet weather in July and August. Most writers speak very highly of it as an esculent, and class it as one of the best and most delicious

of mushrooms. Unfortunately it is not very common with us.

The Sweetbread mushroom, *C. orcella*, is so closely related to the Plum that some have thought it to be a mere variety of it. It is similar in color, though generally of purer white, a little smaller and more irregular, and the flesh softer. In flavor and odor they are the same. The Sweetbread mushroom often grows in pastures and open places, and is to be sought in warm wet weather in midsummer.

Rev. M. A. Curtis has recorded the Silky volvaria, *V. bombycina*, as edible; also the Showy volvaria, *V. speciosa*. Both of them are extremely rare in our country, and having had no opportunity to prove them, description will be omitted.

I have eaten moderately of the Abortive mushroom, *Clitopilus abortivus*, without any ill results; but its flavor was not very agreeable to me, and for this reason I forbear to recommend it to others. When fresh, it has the farinaceous odor characteristic of many edible species, and perhaps greater care in the selection of specimens and better cooking may make it more agreeable.

The Fawn-colored pluteus, *P. cervinus*, is said in the notes of an enthusiastic mycophagist to be, when cooked "juicy, mild in taste and as tender as egg-plant." This is a common species, cleanly in its habits, growing on stumps and decaying wood throughout the season and in many parts of the country. If it shall prove to be a good mushroom, it will be a valuable addition to the list of pink-gilled edibles.



## X. EDIBLE AMANTAS AND AMANTOPSIS.

The *Leucosporae*, or white-spored agarics, include many genera and many species that are edible. In a few instances the spores have a dirty white or a pale yellow color, and in one case a green color, but this is not an edible species. In another they quickly assume a pale lilac tint upon exposure to the air and light.

The esculent species are distributed in about a dozen genera, and the following table may be of service in assigning each species to its proper genus:

### GENERA OF LEUCOSPORE.

Plant with a membranous sheath at the base of the stem, or with superficial warts on the cap,	1.
Plant destitute of sheath and superficial warts,	2.
1. Stem furnished with a collar,	<i>Amanita.</i>
1. Stem destitute of a collar,	<i>Amantopsis.</i>
2. Gills narrow, with a blunt edge,	<i>Cantharellus.</i>
2. Gills with an acute edge,	3.
3. Gills somewhat waxy in texture,	<i>Hygrophorus.</i>
3. Gills not waxy in texture,	4.
4. Cap eccentrically or laterally attached to the stem, or stemless,	<i>Pleurotus.</i>
4. Cap centrally attached to the stem,	5.
5. Gills free from the stem,	<i>Lepiota.</i>
5. Gills attached to the stem,	6.
6. Stem furnished with a collar,	<i>Armillaria.</i>
6. Stem destitute of a collar,	7.
7. Stem firm but brittle (breaking squarely),	8.
7. Stem not brittle,	9.
8. Gills exuding a white or colored juice where wounded,	<i>Lactarius.</i>
8. Gills exuding no juice where wounded,	<i>Russula.</i>
9. Dry plant reviving on the application of moisture,	<i>Marasmius.</i>
9. Plant putrescent, not reviving,	10.
10. Edge of the gills notched or excavated at the stem,	<i>Tricholoma.</i>
10. Edge of the gills even, gills mostly decurrent,	<i>Clitocybe.</i>

In the genus *Amanita* the young plant is enveloped in a mem-

brainous or tomentose wrapper, which is ruptured by the growth of the plant. In some species the remains of the ruptured wrapper or volva form a kind of cup or sheath about the base of the stem of the extruded plant; in others a part of the wrapper is carried up on the surface of the cap, and remains on it in small irregular patches, or in the shape of numerous small warts or prominences, which are easily separable from it. It thus sometimes happens that the warts are washed off by heavy rains. The cap is regular, convex or quite flat when mature, and often a little sticky when moist. The gills are free from the stem, and the stem is furnished with a collar.

Inasmuch as some of the most dangerously poisonous species known belong to this genus, it is very important that the specific characters of the edible ones should be clearly understood by those who would use them for food. Mistakes here are attended with too much risk to be lightly made. And yet some of our best mushrooms belong to this genus, and it is therefore unwise to deprive ourselves of their use through lack of confidence in our ability to recognize a good thing when we see it.

The Orange Amanita or Orange mushroom, *Amanita caesarea*, is a large and attractive species. Its cap is at first commonly bright-red or brownish-red, but with advancing age it fades to yellow on the margin, and sometimes becomes entirely yellow.

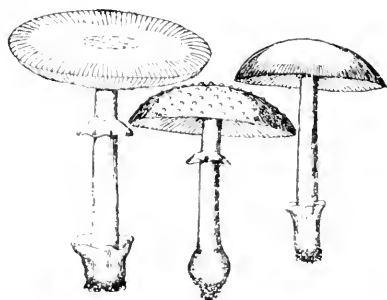

*Amanita caesarea.*    *A. rubescens.*    *A. virginata.*

The margin even in the young plant, is marked by distinct impressed parallel, radiating lines or striations. The flesh is white, tinged with yellow just beneath the separable epidermis, and also close to the gills. The gills are yellow, a very good mark of distinction in this species. The spores, however, are white. The stem is also yellow, as well

as its collar, but the distinctly membranous wrapper at its base is white. The stem is either stuffed with a soft cottony pith or hollow. The expanded cap is 3 to 6 inches or more broad, and the stem 4 to 6 inches long and  $\frac{1}{2}$  inch or more thick. The plant grows in woods and groves, or their borders, and may be found during warm, showery weather from July to September. Sometimes it grows in arcs of large circles.

This mushroom has long been held in high estimation. Having once graced the table of a Roman emperor, it received the name Caesar's mushroom. One ancient writer terms it "Cibus Deorum," the food of the gods. It has also received such names as Imperial mushroom, True Orange, Yellow Egg and Kaiserling. All authors who have written of its esculent qualities agree in calling it "delicious." Cordier says it is an exception to the general rule which makes young plants better than mature ones, implying that it is just as tender and good when old as it is when young.

There is a poisonous species with which a careless person might confuse it. I refer to the Fly amanita, *Amanita muscaria*, which is sometimes called the False Orange. In size, shape and color of the cap there is a similarity between them, but in other respects the two are very different. They may be contrasted as follows:

ORANGE AMANITA, *Edible*.—Cap *smooth*, gills *yellow*, stem *yellow*, wrapper *persistent*, *membranous white*.

FLY AMANITA, *Poisonous*.—Cap *warty*, gills *white*, stem *white* or slightly *yellowish*, wrapper *soon breaking into fragments or scales*, *white* or *yellowish*.

While the Orange amanita is a king among mushrooms, and, from its symmetrical form and bright colors is beautiful to behold, the Reddish amanita, *A. rubescens*, has a peculiarly sordid and uninviting appearance because of its dingy colors. The color of the cap is quite variable. It may be whitish tinged with dull pink, or it may be grayish-red, or even brownish-red. Sometimes the margin is paler than the centre, and again there may be darker reddish stains in various places on it or on the stem. The cap is usually warty, but the warts are easily removable, and are sometimes washed off by heavy rains. The margin is generally even, but in mature plants it is sometimes marked with slight striations. The flesh is white or slightly tinged with red. Wounds on any part of the plant sometimes slowly assume a reddish color, but this is not a constant character.

The gills are whitish, sometimes marked with reddish stains or spots in mature plants. They are mostly narrower toward the stem than toward the margin. The stem is of a pale or whitish color, and often bears dull, reddish stains or marks, especially toward the base. It has a bulbous base, the bulb being sometimes abrupt and sometimes pointed below. It is commonly a little scaly, branny or mealy in young and fresh plants, but frequently smooth in mature or old ones. It is either stuffed or

hollow. The collar is flabby, and often lacerated and imperfect. The wrapper is very friable, and its remains at the base of the stem are so evanescent that frequently no traces of it are seen. Were there no warts on the cap, such specimens would scarcely be thought to belong to the genus *Amanita*.

The cap is commonly three to five inches broad, and the stem three to six inches long. This mushroom grows either in woods or in open, grassy places, and occurs here from July to September. It has been regarded by some of the old writers as poisonous, suspected, or of doubtful quality, but more recent authors agree in classing it among the edible species. Cordier says it is one of the most delicate mushrooms; Cooke says it is a very common, safe and useful species, and Stevenson pronounces it delicious and perfectly wholesome and valuable on account of its abundance.

In this country it is much more common than the Orange mushroom.

If attention is given to its sordid colors, its reddish stains, and the almost total absence of remains of the wrapper at the base of the stem, there need be no fear of confusing it with any poisonous species.

The Fir cone amanita, *Amanita strobiliformis*, sometimes called the "Warted mushroom," is a very large, heavy species, whose cap is adorned with firm, persistent warts. It is sometimes found in the more southern States, and is considered an excellent esculent species; but not having any acquaintance with its edible qualities, it is dismissed from further consideration here.

The genus *Amanitopsis* differs from *Amanita*, to which it was formerly joined, chiefly in the absence of the collar from the stem. We have a single edible species which is so variable in color that its different forms have received several different names. It is the Sheathed amanitopsis or Sheathed mushroom, *Amanitopsis vaginatus*.

The cap is rather thin and fragile, convex or nearly flat when mature, perfectly smooth, or rarely with one or two patches of the ruptured wrapper still adhering to it, and distinctly marked on the margin with deep striations, as in the Orange mushroom. Its gills are narrowed toward the stem, but not attached to it. They are white or whitish, generally a little more dingy in the dark-colored variety. The stem also is white or dingy white, and commonly sprinkled with minute mealy or branny particles or flocculent scales, especially in the young, vigorous plant. It

is either hollow or stuffed with a cottony pith. It is not bulbous, but its base is sheathed with a soft, flabby membrane, the remains of the wrapper. This is such a marked feature that it has given name to the plant. But this sheath adheres very slightly to the base of the stem, and if the plant is carelessly pulled up, it is left in the ground. The cap is 2 to 4 inches broad, and sometimes has a small prominence or umbo in its centre. The stem is 3 to 5 inches long and 1-3 to 1-2 an inch thick.

The plant grows singly or scattered either in woods or in open places. A favorite place of growth is in the deep vegetable mold or humus of dense damp evergreen woods of hilly and mountainous districts. It sometimes grows on much decayed wood. It occurs from June to October.

In the white variety, var. *alba*, the whole plant is white. This is *A. nivalis* Grey., and *A. fungiles*, Batsch.

In the Livid variety, var. *livida*, the cap is of a livid or leaden-brown color, and the gills and stem have a slightly dingy or smoky tint. This is *A. livida* and *A. spadicea* Pers.

In the Tawny variety, var. *fulva*, the cap is tawny-yellow or pale-ochraceous. This is *A. fulva* Schaeff.

The Sheathed mushroom is at once distinguished from the known poisonous species of amanitas by the absence of a collar and of a bulbous base from its stem.

Some of the older authors classed it among the doubtful or suspected species, but it is now regarded as not only harmless but edible. Stevenson says it is edible and of excellent flavor. Cordier says of it, "A delicate food;" Planchon, "Truly delicate;" De Candolle, "Most delicious." Cooke gives preference to the white forms, but says the mouse-colored forms are most common. In our country also the white forms are scarce. My own experience indicates that it is a fairly good mushroom, but there are many others that I like better.

## XI. LEPIOTAS AND ARMILLARIA.

The genus *Lepiota* agrees with the genera *Amanita* and *Amanitopsis* in having the gills free from the stem, but it differs from them in having no distinct enveloping wrapper in the very young plant, and consequently no warts on the cap and no sheathing membrane or scales at the base of the stem. In some of the species the epidermis of the cap breaks up into small fibrillose fragments, so that the cap is scaly but not warty.

The Parasol mushroom or Tall lepiota, *Lepiota procera*, is a conspicuous fungus, which grows in fields, pastures, waysides or thin woods. Its cap, when very young, resembles an egg in shape. It is covered with a reddish-brown epidermis, which breaks up, with its expansion, into brownish spot-like scales.



*Lepiota procera*, *L. naucinoidea*, *Armillaria mellea*, parasol, and this with the prominent umbo and the long slender stem so simulates an outspread parasol that it has given rise to the common name of the fungus. The flesh is rather dry and somewhat tough, and of a white color. The gills are also white or yellowish white, and gradually narrowed toward the stem. They do not reach the stem but leave an open space around it, so that it appears to be inserted in a cavity or shallow basin in the lower surface of the cap. The stem is very tall, straight or a little flexuous, swollen or somewhat bulbous at the base, and often variegated by brown-

ish spots or scales, but this is not a constant feature. It is either hollow or stuffed with a webby pith. Its collar is thick and firm, and soon becomes loose and movable on the stem. The stem is 5 to 10 inches long and only  $\frac{1}{2}$  an inch, or even less, in thickness. The cap is commonly 3 to 6 inches broad. The plants usually grow singly, but sometimes clusters of several are found.

The Parasol mushroom has been highly commended, and belongs among mushrooms of the first-class, both in size and quality. "One of the most delicate species, although the flesh is slightly tough;" "almost the greatest, if not the greatest favorite with the fungus-eaters;" "very delicate, of easy digestion and in great demand" are some of the recorded utterances in its favor. Unfortunately it is not very abundant.

There is no poisonous species with which it can be confused by any intelligent observer.

There is a rare form in which the umbo and spots are much plainer than usual, and the whole plant, except these, is white.

In some places a mushroom occurs which closely resembles the Parasol mushroom, but it has no umbo and the cap has a more shaggy appearance. This is probably the American form of the Ragged mushroom, *Lepiota rhacodes*, a European species which is also classed as edible, and which some recent authors regard as a mere variety of the Parasol mushroom.

The smooth lepiota, *Lepiota naucinioides*, is about as large as the common mushroom, generally very regular in shape and of a clear white color, but sometimes there is a yellowish or even a smoky or brownish tint on the disk of the cap. The cap is usually so smooth and even that the plant is appropriately called the Smooth mushroom. Occasionally a slight mealiness or granular roughness develops in the centre of the cap, and still more rarely the epidermis cracks in such a manner as to give the appearance of thick imbricating scales. The gills are white until old age or dryness causes them to assume a smoky brownish hue, with a slight pinkish tint added. In this condition the plant is likely to be mistaken for the Chalky mushroom, *Agaricus cretaceus*, but if the color of the spores is noticed, there need be no such mistake, for they are *white* in the Smooth mushroom, *brown* in the Chalky mushroom. But both species are edible, so that such a mistake would not be serious in a physical point of view. The stem is white, and generally it gradually becomes thicker toward the base so that it may be said to have a bulbous base gradually tapering into the stem above. It is hollow, but the cavity often contains a delicate webby or cottony pith. The col-

lar has a thick external edge, but its inner edge is so thin that it sometimes breaks loose from the stem and becomes a movable collar like that of the Parasol mushroom.

This species grows especially in grassy places, such as lawns and pastures, but it is also found in fields, by roadsides and even in thin woods. It occurs from August to November.

The Smooth mushroom has a white and generally tender flesh, and is scarcely inferior to the Common mushroom in edible qualities. Some have thought its flavor less agreeable, but others esteem it quite as good. One correspondent writes that "it grows abundantly here, and is one of our finest edible mushrooms. I have taught our people to eat it, and it is now highly prized in this region." It is sometimes mistaken for the common mushroom, so close is the resemblance between the two in habit, size and color, but the white gills of the one and the pink gills of the other should be sufficient to distinguish them before maturity, and the hollow stem and thick-edged collar of the one and the stuffed stem and thin collar of the other after maturity. The dangerous Vernal amanita, *Amanita verna*, need never be mistaken for either of these, if the fact is borne in mind that its gills are *always white*, that it has a *tall stem* with a *large abrupt bulb* at its base *marginied above with the membranous remains of its wrapper*. The Smooth mushroom scarcely differs from the European *Lepiota naucina*, except in its smoother cap and subelliptical spores; the European plant is described as having *glebose spores*.

The "Flaky lepiota," *Lepiota excoriata*, and the "Bossed lepiota," *Lepiota mastoides*, have been recorded by Dr. Curtis among the edible mushrooms of North Carolina. I have seen neither of these species.

Morgan's lepiota, *Lepiota morgani*, a species which occurs in some of the western States, which is very remarkable because of its *green* spores, is to be regarded as an unwholesome species. Eating it has been followed by severe sickness and vomiting. Its gills, which became green in the mature plant, separate it from all other known species in this country.

The genus *Armillaria* commences a series of white-spored agarics, in which the gills are attached to the stem. In this respect it differs from the preceding genera, and in its collar-bearing stem it differs from those which follow.

We have a single very common and very variable edible species. It is the Honey-colored mushroom, *Armillaria mellea*. Because of its variability, it is not so easy to describe it as it is



to recognize it after its peculiar appearance is once known. The typical form has the cap adorned with numerous minute tufts of brown or blackish hairs or fibrils, which are often so crowded on and near the centre as to give that part a darker hue than the rest. Sometimes these fibrils are so dense and matted that they give a woolly appearance to the surface of the cap, and in other cases they are entirely wanting, and the cap is smooth. An umbo is occasionally present in the centre of the cap, and generally mature plants have the margin more or less striated. The color varies from a pallid or whitish hue to a dark reddish-brown, but the most common color is a brownish-yellow, that suggests the name "honey-colored." The flesh is white or whitish, and the taste in the raw state is rather harsh, acrid or unpleasant. The gills are at first whitish, but they become more dingy with age, and are then often spotted or stained with reddish-brown. Sometimes they are slightly excavated or notched on the edge just before reaching the stem; again they run evenly to it, and often extend downwards a little on it—that is, they are decurrent. They are sometimes dusted by the abundant white spores. The stem also varies from pallid to brown. It is usually more or less fibrillose or floccose, and often shows a white or even an olive-green tomentum at its base. It is stuffed or hollow. Its collar is either of a thick cottony texture or thin and membranous. Sometimes it is so thin, and even webby, that it soon disappears.

The plants grow scattered or in gregarious groups or in clusters. The latter is the most common method, and these clusters are sometimes so large that a single tuft would nearly fill an ordinary water-pail. Generally the cap is 1 to 6 inches broad, and the stem 1 to 6 inches long and one-fourth to three-fourths of an inch thick. This mushroom does not often appear in abundance until near the end of summer or the beginning of autumn, but specimens have occasionally been seen in June. The tufted forms grow especially about stumps or on old decaying prostrate trunks of trees. It seems to grow equally well in woods and in open places. Monstrous forms sometimes occur, and an abortive form, not distinguishable from the abortive form of *Citopilus abortivus*, is sometimes found growing with well-developed forms. These are whitish, somewhat globular, one inch or more in diameter, with no definite distinction of cap and stem. The taste is farinaceous, and the edible qualities are quite as good as in the normal form.

The following varieties may be noticed:

Variety *bulbosa* has the stem bulbous.

Variety *radicata* has a root-like prolongation to the stem which penetrates the ground deeply.

Variety *albida* has the cap nearly white.

Variety *obscura* has the cap covered with numerous small black scales.

Variety *flava* has the cap pale yellow.

Variety *glabra* has the cap smooth.

Variety *exannulata* has the collar obsolete or wanting, and the clustered stems generally tapering toward the base.

Authors do not agree concerning the edible qualities of this mushroom. Formerly it was considered poisonous, but recent writers admit it to be harmless, although some assert that it is of inferior quality and flavor.

Cordier says that it is edible, and loses its acidity in cooking. Others affirm that it is harmless, but that it does not entirely lose its acidity in cooking. Vittadini says that it is preserved in vinegar, salt and oil for winter use. Both he and Gillet say that its disagreeable flavor disappears in cooking. Stevenson says it is edible but tough. Having eaten it repeatedly, and prepared in different ways, without suffering any ill effects, save occasionally a slight burning sensation in the throat, I have no hesitation in classing it as a harmless and an edible species, but not of the first quality. Only the caps of young and tender plants should be used. I do not know of any deleterious species for which it is likely to be mistaken.

## XII. THE TRICHOLOMAS.

The genus *Tricholoma* is known by its stout, fleshy stem, destitute of a collar, and by its gills being attached to the stem, and having a shallow excavation or notch in the edge at or near the inner extremity. The species are numerous, and grow in woods and in fields or open places. Opportunity has been afforded for the trial of only a few of them. The following table may aid in finding the description of the species here discussed:

Cap viscid,	1.
Cap not viscid, dry or moist,	2.
1. Cap yellowish, gills yellow,	<i>T. equestre</i>
1. Cap reddish-brown, gills not yellow,	<i>T. transmutans</i>
2. Cap reddish-brown, gills when old more or less spotted with dull red,	<i>T. imbricatum</i>
2. Cap grayish-brown or blackish-brown, cov- ered with hairy fibrils or scaly,	<i>T. terreum</i>
2. Cap smooth, commonly grayish-violaceous,	<i>T. personatum</i>

The Equestrian tricholoma, *Tricholoma equestre*, is easily recognized by its sticky viscid cap of a yellowish color, and by its bright sulphur-colored or canary-yellow gills. The cap is firm and smooth, or sometimes with a slightly scaly appearance in the centre, where it is also usually tinged with dingy reddish or reddish-brown hues, the yellow being more clear and distinct toward the margin. The flesh is white, and has a farinaceous taste, though no marked odor. The gills are a beautiful pale yellow, and on this account they have suggested to an esteemed correspondent the name "Canary mushroom," which he applies to this species. They are closely placed side by side, and deeply notched or rounded at the extremity next the stem. The stem is short, stout and solid, and is either white or yellowish.

The cap is two to four inches broad and is sometimes irregular, the margin being wavy or some parts more elevated than others. The stem is commonly one to two inches long and one-third to two-thirds of an inch thick. With us it is more often white than yellow. The Equestrian mushroom or "Fir-tree tricholoma," as it has been called by one writer, grows in or near pine woods and groves. It is especially to be found among

scattered young pines, often called "second growth" pine, or "pine thickets," where it has a fair supply of sunlight. It appears in autumn, and in the more southern States continues through December.

It has not before been classed among the edible species, but at least two of my correspondents have eaten it freely, and one of them says that he and his family regard it as the best of two or three kinds that they have been in the habit of eating. I therefore confidently add it to the list of edible species.

From the Sulphur tricholoma, *Tricholoma sulphureum*, which has been suspected of being dangerous or unwholesome, and which is wholly of a sulphury yellow color, our plant is

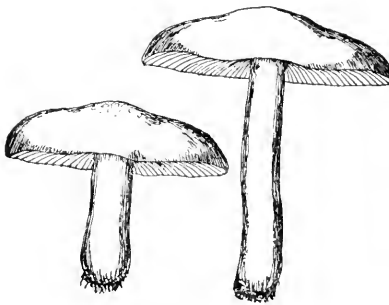

*Tricholoma equestre.* *T. transmutans.*

easily separated by its viscid cap, closer gills and paler solid stem, for the cap of the sulphury mushroom is not viscid, its gills are wide apart, its stem is stuffed or hollow, and of a sulphur-yellow color, and besides, the plant has a strong disagreeable odor.

The Changing tricholoma, *Tricholoma transmutans*, has the cap viscid or sticky on the surface when moist. It is at first tawny-red, but becomes reddish-brown with advancing age, sometimes retaining the paler hue on the margin longer than in the centre. The flesh is white and has a decided farinaceous odor and taste. The gills are closely placed, notched at their inner extremity, as is usual in all species of this genus, at first whitish or yellowish white, but becoming dingy with age and usually exhibiting reddish-brown spots or stains. The stem is almost as long as the diameter of the cap, but in exceptional cases it may be much shorter. It is paler than the cap, becoming darker when old than it was when young. It is stuffed or hollow. The cap is two to four inches broad, the stem two to four inches long and usually about half an inch thick.

The Changing mushroom grows in woods and in open places, either singly or in tufts. When it grows in tufts the caps are often irregular because of crowding upon or against each other. It is a rather late growing species, appearing in wet weather from August to October in this latitude. It is a good acquisition to our food supply.

The Changing mushroom grows in woods and in open places, either singly or in tufts. When it grows in tufts the caps are often irregular because of crowding upon or against each other. It is a rather late growing species, appearing in wet weather from August to October in this latitude. It is a good acquisition to our food supply.

The Imbricated tricholoma, *Tricholoma imbricatum*, closely resembles the Changing tricholoma in size, color and taste. It is, however, easily separated by its *dry* cap and *solid* stem. Its cap is reddish-brown or cinnamon-brown and its surface often presents a somewhat scaly appearance because the epidermis becomes lacerated or torn into small irregular fragments which adhere and seem to overlap like shingles on a roof. The flesh is firm, white or whitish and has a farinaceous taste and odor.

The gills scarcely differ in color and character from those of the preceding species, and the stem is colored nearly like the cap but usually is a little paler. When old it is sometimes hollow from the erosion of insects whose larvæ are fond of the flesh.

The Imbricated mushroom grows under or near coniferous trees and appears in autumn. It is sometimes associated with the Changing mushroom, and also with the very similar *Vaccine tricholoma*, *Tricholoma vaccinum*, and it has the same habit of growth as these. All of them often grow in close clusters or tufts. The *Vaccine* mushroom is separated from the Imbricated mushroom in having the margin of the cap, when young, covered with a soft downy or cottony coat, the stem hollow and the taste bitter and unpleasant. Still it is recorded as edible by Gillet, so that if it should be confused with either of the two foregoing species probably no serious harm would result. The good flavor of the others might be impaired by the inferior flavor of this one.

The Gray tricholoma, *Tricholoma terreum*, is an exceedingly variable species, both in size and color. The cap is dry and clothed with hairs or fibrils which are often collected in small tufts or scales. When expanded it is nearly flat, but in many cases it has a small central prominence or umbo. Its color varies in different plants from gray to blackish-brown. In one locality the dark colored forms have received the name "black-cap" mushroom. The flesh is thin toward the margin and usually dingy or grayish-white. Its taste in most cases is farinaceous, but this is not a uniform character in all the forms. The gills are broad, rather wide apart, usually rounded behind, that is, next the stem, of a dingy white or grayish color, and often eroded or uneven on the edge. The stem is whitish, or at least paler than the cap, and is stuffed or hollow.

The cap is one to three inches broad, and the stem one to three inches long and one-sixth to one-half an inch thick. The plant appears in autumn, and in some of the southern States may be found as late as December or even January. It grows in

woods, and especially pine woods, also in open places. It has not been classed among the edible species by European writers, but it has been repeatedly eaten in this country, and I myself have partaken of it. It is not very attractive in flavor, and probably should be classed as a second or third rate mushroom, but it is better than none and is described here for the benefit of those who are not particular about the flavor, and who may not always be able to get better ones.

The Masked tricholoma, *Tricholoma personatum*, on the other hand, is one of the best flavored mushrooms, and fortunately has a wide range, and is sometimes found in considerable abundance. When young the cap is very convex and firm with the margin minutely downy or sprinkled with a slight mealiness and incurved. In the mature plant it is softer, broadly convex or nearly plane with the thin margin spreading and naked. In

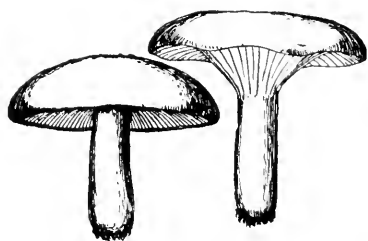

*Tricholoma personatum. Clitocybe media.*

very wet weather it is apt to be water-soaked and to have the margin wavy, or even turned upwards, giving the cap a sort of cup-shape. Usually it is pale lilac when young, changing with age to tawny or rusty hues, especially in the centre. Sometimes the cap is whitish or gray or pale violaceous. Its flesh when dry is whitish, and has an agreeable, pleasant flavor.

The gills are closely placed, rounded next the stem, more narrow toward the margin of the cap, and of a pale but undecided color, often with a faint shade of lilac or violet, especially when young.

The stem is rather short and stout, solid, adorned with inconspicuous fibrils and downy or mealy particles when young and fresh, but becoming smooth with maturity. It is often slightly thickened at the base, and in variety *bulbosum* it is distinctly bulbous. Its color is similar to that of the cap, but usually a little paler.

The cap is 2 to 5 inches broad, and the stem 1 to 3 inches long and generally  $\frac{1}{2}$  to  $\frac{3}{4}$  of an inch thick. Usually it grows singly or in groups, but occasionally in clusters of several individuals. It occurs in autumn, sometimes continuing very late in the season, and should be sought in thin woods and open bushy places.

Nearly all writers on this subject speak well of its edible qual-

ities, and my own experience confirms their estimate, and leads me to consider it a first-class mushroom.

I do not know of any dangerous species with which it can be compared, but there are other species that resemble it somewhat in color. Its spores are not a pure white, but rather whitish or dirty white in color. The gills are separable from the cap, especially toward the stem. In England the plant has received the common name "Blewits," and in France, "Blue-stem," though its color can scarcely be called blue.

Its smooth, almost shining, unbroken and unadorned epidermis, and its peculiar lilac tints distinguish it from all other species of the *Tricholoma* here described.

### XIII. THE CLITOCYBES AND COLLYBIA.

The genus *Clitocybe* has the gills attached to the stem, as in *Tricholoma*, but they are not rounded or notched on the edge next the stem. They are united to the stem by their whole width, and usually they are prolonged downward on the stem, or in other words are decurrent. This is the principal character by which they are separated from the genus *Tricholoma*.

More than twenty species of this genus have been classed as edible, but it has been permitted us to test but a few of them. Those here noticed may be tabulated as follows:

- |  |                               |
|--|-------------------------------|
| Cap thick-fleshed or broadly obconic,            | 1.                            |
| Cap not thick-fleshed or not obconic,            | 2.                            |
| 1. Cap grayish, gills close together,            | <i>C. nebularis</i> .         |
| 1. Cap brown or blackish-brown, gills not close, | <i>C. media</i> .             |
| 2. Cap rather thin, funnel-shaped when mature,   | <i>C. infundibuliformis</i> . |
| 2. Cap thin, convex or plane,                    | <i>C. laccata</i> .           |

The Clouded clitocybe, *Clitocybe nebularis*, takes its name from the clouded-gray appearance of its thick cap, which is at first convex, but when mature, either flat or a little depressed. Its flesh is white, thickest in the middle, and in a vertical section is seen to taper rapidly downward into the stem. The gills are close together and rather narrow for the size of the plant. They are white or yellowish-white. The stout solid stem usually tapers upward from the base and is whitish.

The cap is two to four inches or more broad, the stem one to two inches long and about half an inch thick. The Clouded mushroom grows in woods, and sometimes forms large tufts or clusters among fallen leaves. It is found in autumn, but is not very common in this country. Authors differ in their estimate of the edible qualities of this mushroom, but the more recent ones generally agree in classing it as edible.

Still more rare is the intermediate clitocybe, *Clitocybe Media*. This species grows among moss in dense woods in cool mountainous places. Its cap is grayish-brown or blackish-brown, being generally darker-colored than that of the Clouded mushroom. Its flesh is white and mild in taste. The gills are whitish, wide apart, and have little transverse ridges or veins in the spaces be-



tween them. The stem is short and not at all or but slightly thickened at the base. It is a little paler than the cap. The species may be distinguished from the Clouded mushroom by its darker cap, its less tapering stem, and especially by its gills having wider and veiny interspaces between them. From the Club foot elitocybe, *Clitocybe clavipes*, it differs but slightly. Its flesh is less soft and spongy, its cap less narrowly obconic, and its stem shorter and more cylindrical. To my taste it has an excellent flavor, and I could wish it more abundant. It has been found in autumn only.

The Funnel-form elitocybe, *Clitocybe infundibuliformis*, is a neat and pretty species easily recognized by the funnel shape of its mature cap and by its pale red color. When very young the cap is slightly convex and often adorned with a slight umbilic in its centre. As it matures the margin becomes elevated so that the cap assumes a shape somewhat resembling that of a wine glass. The margin is sometimes wavy. The flesh is thin and white. The gills are close, thin white or whitish and decurrent. The stem is smooth, colored like or a little paler than the cap and mostly tapering from the base upward.



*Clitocybe infundibuliformis.*      *C. laccata.*

The cap is two to three inches broad, the stem one and a half to three inches long and one-fourth to one-half an inch thick.

The Funnel-shaped mushroom grows in woods or copses in summer and autumn, especially in wet seasons. It is somewhat variable in color, but is usually a pale red, tinged with buff, and sometimes becoming more pale with age. It delights to grow among fallen leaves, and often there is an abundant white cottony mycelium at the base of the stem. When it grows in clusters the caps are apt to be irregular because of mutual pressure.

The Laccate or Waxy elitocybe, *Clitocybe laccata*, is a small species, one of our most common and variable, yet one most easily recognized when its distinguishing characters are known. It is a second or third-rate mushroom, thin in flesh, not highly flavored, and apt to be tough, but because it is classed as edible and

because it is common and often even abundant it is described for the benefit of those who may desire to use it.

Its cap is very thin, convex or nearly plain, smooth or with a slight scurfy roughness, sometimes with a small central depression or umbilicus, and when moist with a water-soaked appearance, by the drying out of which moisture the color fades very decidedly. When moist the color is a peculiar buff-red, dull red or flesh-red, but when dry it assumes a kind of grayish or pale ochraceous hue. The gills are broad, rather wide apart and attached to the stem by their entire width. Sometimes they run downwards a little on the stem and occasionally they have the edge slightly excavated next the stem, contrary to the rule in this genus. They have a peculiar pale flesh-color which is more persistent than the color of the cap, and which is one of the most characteristic features of the species. They are apt to become dusted with the white spores when mature. The stem is rather long and slender, having a fibrous appearance externally and being stuffed or almost hollow within. There are many varieties. In one, the moist cap is much darker than in the typical form, and when dry much paler, but the gills have a beautiful deep violaceous and quite persistent color. This has been called variety *amethystina*. In another the gills are unusually pale, fading almost to whitish. This is variety *pallidifolia*. In a small form growing in wet or damp places the moist cap is smooth and so thin that it shows shadowy radiating lines extending from near the centre to the margin. This is variety *striatula*.

As usual, such a variable species is not at all particular as to its place of growth, but may be found in woods, swamps or fields, growing on naked soil or among grass, mosses or fallen leaves. It is especially fond of growing in pine woods or groves. It may be found from the beginning to the end of the season if the weather is not too dry. It usually grows in groups or flocks and makes up in numbers what it lacks in size. The cap varies from half an inch to two inches broad, the stem from one to three inches long and one to three lines thick.

There is a closely related but much larger mushroom, *Clytocybe ochropurpurea*, in which the cap is generally paler and the gills brighter in color, having a purplish tint. It has a comparatively shorter and thicker stem and the whole plant is apt to be more irregular and deformed and the gills transversely torn. This is not known to be edible.

The Rooting mushroom, *Collybia radicata*, belongs to a closely related genus of white-spored agarics and is recorded as edible,

but I have not tried it. It is easily known by the root-like prolongation of the stem which penetrates the earth deeply like a tap-root, and which suggests the name of the fungus. The cap is thin, viscid when moist, grayish-brown, and often a little wrinkled or corrugated on its surface. Its gills are white, broad, not close and have the edge excavated near the stem as in *Tricholoma*. The stem is slender, tapering upward, and hollow. The plant is common in thin woods and under trees in summer and autumn.

#### XIV. PLEUROTUS—HYGROPHORUS— LACTARIUS.

The genus *Pleurotus* differs from all that have preceded in having the cap attached to the stem eccentrically or laterally, or in being entirely destitute of a stem. In the other genera noticed, the cap is attached to the stem by the central part of the lower surface. In this genus the gills in some species are notched as in *Tricholoma*, in others they are adnate or decurrent as in *Clitocybe*. Besides, nearly all the species (all here discussed) grow on dead or decaying wood. They are more tough in texture than those growing on the ground, and are therefore less desirable for food. Still they may be utilized in making soups, or in giving flavor to other more tender but less sapid species.

The Elm pleurotus, *Pleurotus ulmarius*, takes its name from its habit of growing on elm trees. It appears in autumn, and often may be found, even in the beginning of winter, standing out as a conspicuous white object from dead places in the trunks of elm trees or from the cut surface of their branches. Even the shade trees of the streets of our cities sometimes produce a crop of the elm-tree mushroom. Its cap is large, thick and firm, smooth, broadly convex or nearly flat, and white or whitish

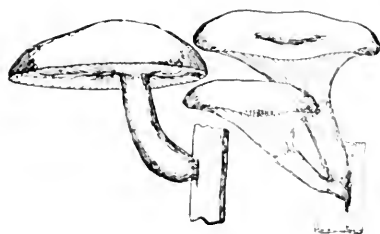

*Pleurotus ulmarius*.

*P. sapidus*.

with the centre generally stained with rusty or dull yellowish hues. Sometimes the epidermis cracks in areas, giving the sur-

face a tessellated appearance or in longitudinal cracks extending from the centre toward the margin. The flesh is firm and white. The gills are white or yellowish-white, broad, rounded or notched next the stem, and not very closely placed. The stem is firm, solid, smooth or a little hairy at the base, white or whitish, and attached eccentrically to the cap. It is often curved, especially when growing from the side of a trunk or branch.

The cap is three to five inches broad, the stem two to four inches long and one-half to three-fourths of an inch thick. It is not limited in its place of growth to elm trees, but sometimes occurs on maple and poplar trees also. It is sometimes difficult to collect because of its growing high above the ground. Its late growth seems to make it comparatively free from the attacks of insects. Most tree-inhabiting species are quite slow in their growth, and the longer they are in developing, the tougher their substance and the slower their decay as a rule. Such species may be easily dried and preserved for winter use. Dr. Cooke mentions this mushroom as an old favorite and the best of all this group of tree inhabiting species. He mentions one specimen which was so large that it furnished a meal for three or four persons. Quelat says it is sapid, but should be eaten while young. This seems to me to be good advice in regard to all the tree-inhabiting mushrooms.

The Sapid pleurotus, *Pleurotus sapidus*, generally grows in clusters whose stems are more or less united at the base. The caps crowd and overlap each other, and are often very irregular. They are smooth and vary much in color, being whitish, yellowish, ash-gray, dull-lilac or brownish. The flesh is white. The gills are white or whitish, rather broad, and run down on the stem, and there are slightly connected with each other by a few oblique or transverse branches. The stem is generally short, solid and white or whitish, and either laterally or eccentrically connected with the cap. Very rarely specimens of this and of the Elm-tree mushroom may be found having a central stem.

Although this belongs to the white-spored species in a systematic classification, its spores really exhibit a pale lilac tint after a short exposure to the air. In size it varies, the cap being commonly two to five inches broad, and the stem one to two inches long. It grows in woods and open places as well, and may be found in wet weather from June to November. It grows on trunks and stumps of various kinds of deciduous trees, such as elm, oak, beech, birch, maple and horsechestnut. In edible qualities it appears to me to rank with the Oyster mushroom. Ac-

ording to Kalchbrenner, it is eagerly sought for food in the woods of Hungary, and is also cultivated on pieces of elm trunks in gardens.

The Oyster mushroom, or Oyster pleurotus, *Pleurotus ostreatus*, probably takes its name from some fancied resemblance between the shape of its cap and that of an oyster shell, rather

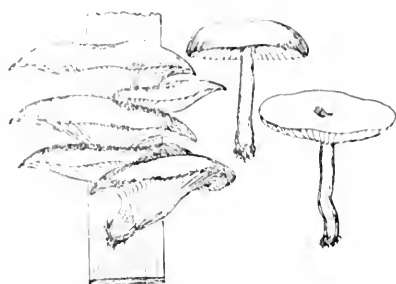

*Pleurotus ostreatus.* *Hygrophorus miniatus.*

than from any similarity between its flavor and that of an oyster. It is closely allied to the Sapid mushroom, has the same colors, though with us it is usually white or merely shaded with yellow, and about the same size and taste. It differs principally in having no stem at all, or only a very short lateral or eccentric one. It grows in clusters, one plant arranged

above another on the sides of dead trunks of standing trees. Its gills are white or yellowish-white and reticulately connected where they run down on the short stem, or at their inner extremity. It is commonly found in autumn, but it may occur also in summer during wet or showery weather. It has long been classed as esculent, but on account of the toughness of the flesh and lack of flavor, it can scarcely be placed among the mushrooms of first quality. Cooke says it should be slowly and carefully cooked, and French writers recommend it only while yet young and tender. For culinary use it is scarcely worth while to keep the Oyster mushroom and the Sapid mushroom apart.

The genus *Hygrophorus* is chiefly distinguished by the character of the gills. These are usually rather thick, wide apart and of a somewhat soft waxy texture. In some species they are similar to the gills of *Tricholoma* in their attachment to the stem; in others, they run down on the stem as in the genus *Clitocybe*, and such species bear so close a resemblance to species of *Clitocybe* that they were formerly associated with them. Many of them have both cap and stem very viscid or glutinous, a character not found in any of our *clitocybes*. No dangerous species are known, but one or two have been suspected of being at least unwholesome. We have several species that have been placed in the edible list; for example, the Ivory hygrophorus, *Hygrophorus eburneus*, the Meadow hygrophorus, *Hygrophorus pratensis*, and

the Virgin hygrophorus, *Hygrophorus virgineus*, but inasmuch as I have not tried them, a single species, the Vermilion hygrophorus, *Hygrophorus miniatus*, will here be described.

It is a small but common species, highly colored and very attractive. The cap is at first convex, but when fully expanded, it is nearly or quite flat, and in wet weather it even becomes concave by the elevation of the margin. It is thin and fragile and its surface is sometimes smooth and shining and in other cases it is roughened as if by numerous scurfy erect scales as in the Laccate mushroom. Its color varies from bright vermilion or blood-red to paler orange hues, and in variety *lutescens* it is wholly yellow.

The gills are yellow, but often shaded with red. They are generally attached to the stem by their entire width at the inner extremity, but specimens sometimes occur in which they are notched near the stem or even slightly decurrent on it.

The stem is usually short and slender, colored like or a little paler than the cap and solid when young, but becoming stuffed or hollow with age.

The cap varies from half an inch to three inches broad; the stem is one to two inches long and commonly one to two lines thick.

The Vermilion mushroom grows both in woods and in the open country, on naked soil or among mosses and fallen leaves. It is sometimes found growing in the sphagnum of peat marshes, and as a rule it is more plentiful in wet weather than in dry. It especially delights in cool mountainous or hilly districts, and in recently burned clearings in such localities. A favorite place of growth also is under a dense luxuriant growth of brakes in the vicinity of mountain forests. In such places it often attains a much larger size than elsewhere. It grows either singly or in groups, occasionally in clusters, and may be found through summer and autumn. In favorable localities it is not difficult to find it sufficiently abundant to furnish a generous supply for the table notwithstanding its small size. It is scarcely surpassed by any mushroom in tenderness of substance and agreeableness of flavor. Two or three other species of *Hygrophorus* have red caps, but two of them, *Hygrophorus coccineus* and *H. puniceus*, are classed as edible, and no harm would come of confusing them with the Vermilion mushroom. Their *viscid* caps, however, would distinguish them. The Chantarelle hygrophorus, *Hygrophorus cantharellus*, is colored almost exactly like the Vermilion hygrophorus, but it is a smaller plant with a longer stem and gills that run down on the stem very decidedly. Its taste to me is very disagreeable.

In species that belong to the genus *Lactarius*, the gills exude drops of a milky or colored juice where cut or broken. In most species this juice exudes from any part of the plant, but most freely, perhaps, from the gills. This character, combined with the brittle vesicular substance, is sufficient to separate these fungi from all others. The stems, though thick and stout, are easily broken, and the fracture is even, not ragged and shreddy, as in a more fibrous substance. In shape and size the species bear considerable resemblance to species of *Clitocybe*, but the flesh, juice, and often the markings of the cap, easily distinguish them.

Many species have a very acrid or hot and burning flavor like that of cayenne pepper. Some writers have recommended the rejection of all such species, and it is a very good rule to observe. The only objection to it is that its observance would deprive us of the use of a few of these species in which the acrid taste is destroyed by cooking. Dr. Curtis records the Unsavory lactarius, *Lactarius insulsus*, and the Peppery lactarius, *Lactarius piperatus*, as edible, though both, when fresh, have a very acrid taste.

The two species here described have been long and well known as safe and edible. One has an orange-colored juice, the other a white or milky juice.

The Delicious lactarius, *Lactarius deliciosus*, is well marked by its peculiar colors, and easily distinguished from all others by its orange-colored juice. The cap is broadly convex in the young plant, but in maturity it is centrally depressed, or, by the elevation of the margin, it becomes funnel-shaped. It is smooth and moist, or very slightly viscid, and of a yellowish or pale orange hue, and adorned with circles or mottled zones of deeper hues. These zones or bands appear to be made of confluent spots. In old plants they

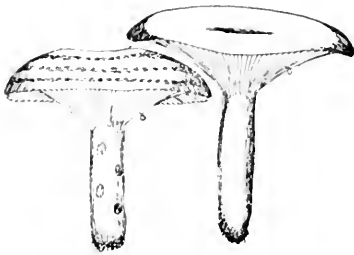

*Lactarius deliciosus.*      *L. volemus.*

are less distinct, and the general color becomes faded, and often varied with greenish stains. Such plants are unattractive, often wormy and unfit for food. The flesh is whitish, stained with orange, especially in the part next the gills. Its taste is often very slightly acrid.

The gills are orange-colored, but clearer than the cap. The orange juice exudes freely from them where cut or broken. It

also exists in other parts of the plant. Wounded places slowly assume a greenish hue.

The stem is colored like, or a little paler, than the cap. It is usually adorned with a few spots of a deeper orange. It is short when the plant grows on naked ground, longer if among moss or leaves. It is generally hollow, especially in mature plants.

The cap is two to five inches broad, the stem one to four inches long, and one-third to two-thirds of an inch thick.

The Delicious lactarius grows in woods, groves and mossy swamps. It is especially fond of pine woods and wet, mossy swamps. It may sometimes be found in swamps when dry weather prevents its growth elsewhere. It occurs from July to October.

It has been abundantly praised by writers on edible mushrooms, most of whom place it among the best. Gillet says, "it is edible, but not as good as its name seems to indicate." Smith says, "it is the most delicious mushroom known." My own experience with it leads me to class it as a very good mushroom, but not equal to the best. It is thought by some that too long and rapid cooking spoils its delicacy and makes it tough. From the color of its juice it is sometimes called the Orange-milk mushroom.

The Orange-brown lactarius, *Lactarius volemus*, is about the same in size and shape as the preceding species, but in other respects, it is very different. Its cap is smooth and uniformly colored, but its color is a peculiar one, apparently a mixture of red, brown and yellow, which has been described as reddish-tawny, golden-tawny, brownish-orange, and orange-brown. The color varies slightly in shade, but not in character. Sometimes the cap has a slight umbo in the centre, and occasionally the epidermis cracks in areas, showing the whitish flesh in chinks. In variety *subrugosus*, the margin of the cap is rough, with reticulating wrinkles or corrugations.

The gills are white or yellowish white, and where cut or broken, exude drops of a white, milky juice. Bruises on them soon assume a brownish hue.

The stem is colored like the cap, but usually a little paler. It is smooth, firm, and commonly solid.

The Orange-brown mushroom grows in woods and in open places. It is especially abundant in thin woods of oak and chestnut, in warm, wet weather, and may be found from July to September. It is quite free from the attacks of insects, but if kept too long before cooking, it is apt to emit a strong, unpleasant



odor. In the raw state it has a slightly harsh or astringent flavor, but all writers agree in classing it among the edible species. It has not the hot, biting flavor of the truly acrid species, and cannot be easily mistaken for any objectionable species. To my taste it is not high-flavored, but fairly good.

## XV. RUSSULAS, FAIRY-RING MUSHROOMS, CHANTARELLES AND VISCID BOLETL.

In the genus *Russula*, the species are similar in size, shape and substance to those of the genus *Lactarius*, but the plants exude no milky or colored juice from wounds. The cap is often red, purple or rosy hued, a circumstance that seems to have suggested the generic name. The colored zones often seen on the cap in species of *Lactarius* are strangely absent in this genus. The acrid and mild flavors observed there are present here, and may be employed as a test of desirability.

The species in many instances are difficult of separation in consequence of similarity and variability in coloring. We will introduce but a single edible species, although several occur within our territory.

The Greenish russula, *Russula virescens*, is easily known from all others by its greenish or grayish-green warty cap. Green is a rare color among mushrooms, and when it does

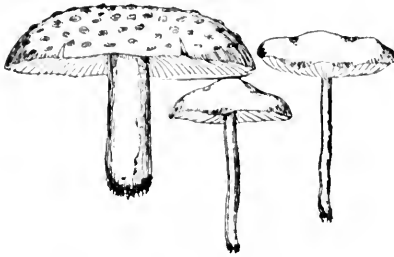

*Russula virescens*, *Marasmius oreades*.

occur, it is not the clear green of flowering plants, but a dull, metallic green or grayish-green. In our plant the surface of the cap is dry, not viscid as in some related species, and is broken up into small warts. The gills are white or whitish, and gradually narrowed toward the stem. This is commonly shorter than the diameter of the cap, white and solid, or merely spongy in texture in the centre. The flesh is white and taste mild. The cap is two to four inches broad, the stem one to two inches long and half an inch or more thick.

The Greenish mushroom grows in thin woods or groves, or in

grassy grounds, and is chiefly found in wet or showery weather during July and August.

It is highly praised as an edible mushroom by some writers, but to me it is scarcely more than second quality.

The genus *Marasmius* is known from all preceding genera of white-spored *Agaricineae* by the tough texture of the small, thin plants that compose it. They quickly dry or wither, but revive again on the renewal of wet weather, or on the application of moisture. The gills also are thin, and rather tough and flexible like the cap. The stem is slender, tough, and often cartilaginous. It may be clothed with a downy or velvety coat, or be perfectly smooth, glossy or shining. Most of the species are too thin and tough to be of value for eating, but the Fairy-ring mushroom, *Marasmius oreades*, has long been classed among the edible species, and long been held in high estimation. Its name has been suggested from its tendency to grow in circles or arcs of circles, "fairy rings" as they are called. In England the plants have been known as Scotch bonnets. When young and moist the cap is pale yellowish-red or tawny-red, but as the moisture disappears, the color fades to pale yellow or buff.

The gills are broad and wide apart, rounded or deeply notched at the inner extremity and slightly attached to the stem. They are whitish or creamy yellow.

The stem is rather slender, solid, tough, and covered with a whitish or grayish close and compact tomentum or villosity which can be scraped away, revealing the surface of the stem beneath.

The cap is generally about an inch across, sometimes more, and the stem is one or two inches long and generally less than a quarter of an inch thick.

The Fairy Ring mushroom loves open grassy places, and grows especially in lawns, pastures and by the roadsides. It may be found from May to October if sufficiently warm and moist weather should prevail. The following are some of the recorded notices of it: It is very good while young; when young, it may be eaten as an omelet; it has a very agreeable taste and odor and gives a delicious flavor to sauces, but it needs cooking a long time; it is recommended especially as a condiment; it is delicious when broiled with butter; it may be pickled or dried for future use; it is a very delicious mushroom, and the abundance in which it everywhere grows, makes it a very valuable one; its tendency to toughness is easily overcome by proper cooking.

One correspondent says that it is excellent for flavoring, but

rather tough if used alone. Another writes that the stems are very tough, but not the caps.

The following method of cooking this mushroom is given: Put the clean caps into sufficient boiling water to make a nice gravy when done, and cook them half an hour. Then rub together a small quantity of flour and water, with salt and pepper, and add to the mushrooms, stirring for a moment. Pour on hot toast and serve in a hot dish.

Another method is to put the caps in water with butter and seasoning, and let them simmer slowly ten or fifteen minutes. Then thicken with flour and serve.

The genus *Cantharellus*, the last of the white-spored agarics to be discussed, is at once distinguished from all the others by the character of the gills. These are narrow and blunt, or rounded on the edge, and in most of the species they are more or less forked or branched. In some species they are connected with each other in a reticulate manner by numerous transverse branches.

One species, the Chantarelle, *Cantharellus cibarius*, has long been known and celebrated for its edible qualities. It is easily recognized by its uniform yellow color, all parts of the plant except the inner flesh being of one color. The cap is

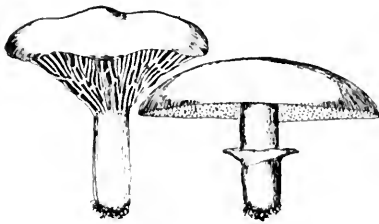

*Cantharellus cibarius.* *Boletus luteus.*

smooth, but often very irregular or unsymmetrical, its margin being wavy or lobed, and its centre being prominent, plane or depressed. Its flesh is often very thick and gradually narrowed downwards, so that the cap has somewhat the appearance of

an inverted cone. It is white within. The narrow, blunt-edged gills run down on the stem, and are more or less branched and connected with each other. The stem also is often irregular, short or long, crooked or straight, cylindrical or tapering downward. It is smooth and solid.

The cap is one to three inches broad; stem one to two inches long, and one-fourth to one-half an inch thick.

The Chantarelle grows in woods or in open places, and may be found from June to September. It is rather common. It usually grows in groups, but sometimes in arcs of circles, as if attempting to form a fairy ring. A favorite habitat is the deep shade of dense evergreen thickets.

The following remarks by various authors show how it has been regarded: "It is justly enumerated among the most sapid fungi;" "no fungus is more popular;" "it is an excellent plant, whether used as a condiment or a food;" "it is edible and delicious;" "by a confirmed fungus-eater it would be pronounced most charming." My own trials of it would lead me to place it among the best and most important of our mushrooms.

The Orange chantarelle, *Cantharellus aurantiacus*, which is not deemed edible, and which has a slight superficial resemblance to this species, may be known by its more dingy-colored cap, and by its orange-colored gills, which branch by a regular bifurcation, not by an irregular ramification. It is much more rare than the Chantarelle.

We now come to a family of fungi called *Polyporeae*, in which the cap has no gills, but instead of them, the lower surface is full of minute pores, holes, or cells. The spores of the fungus are produced in these pores and may be caught as they drop from them, just as in agarics when they are dropped from the gills. Their color, however, is not of the same importance in classification and identification of this family as it is in the preceding ones.

The edible species here noticed belong to three genera, *Boletus*, *Polyporus* and *Fistulina*. Their essential characters may be learned from the following comparative table:

Pores compacted together and forming a continuous stratum,	1. <i>Fistulina</i> .
Pores each in a distinct tube,	<i>Boletus</i> .
1. Stratum of pores easily separable from the cap,	<i>Polyporus</i> .
1. Stratum of pores not separable from the cap,	

In the genus *Boletus* the mass of cells or the porous substance on the lower surface of the cap may be easily and smoothly removed from the cap by pressing it outwardly from the stem toward the margin. This is the chief character by which to separate species of *Boletus* from species of *Polyporus*. Nearly all boleti grow on the ground, have the stem centrally attached to the cap, and have a soft or fleshy substance. Most of the edible species are well-flavored and of a fairly large size. Some have a nutty flavor that is very agreeable to most people. Unfortunately for fungus eaters many of them grow only in warm and wet or showery weather when insects are numerous, and therefore they are very likely to be infested by larvæ. Care must be taken to reject all such specimens. The stems also must be discarded because of toughness, and the pores removed before cooking, for they are apt to form a very disagreeable mucilaginous or slimy

mass in cooking. Some species also have a viscid or slimy surface to the cap, and this causes earth, sticks and leaves to adhere tenaciously to it. It is therefore well to peel such caps before cooking them.

ANALYTICAL TABLE OF SPECIES OF BOLETUS.

Cap viscid when moist,		1.
Cap not viscid,		3.
1. Stem having a collar,		2.
1. Stem destitute of a collar,	<i>B. granulatus,</i>	
2. Stem dotted above the collar,	<i>B. luteus,</i>	
2. Stem dotted both above and below the collar,	<i>B. subluteus,</i>	
3. Stem roughened with prominent colored dots or scales,		4.
3. Stem with no dots or scales,		5.
4. Margin of the cap with adhering fragments of a membranous veil,	<i>B. versipellis,</i>	
Margin of the cap naked,	<i>B. scaber,</i>	
5. Stem solid,	<i>B. edulis,</i>	
5. Stem hollow,	<i>B. castaneus,</i>	

The yellow-brown boletus, *Boletus luteus*, is one of our rarest species. I have seen it in but one locality in New York. Its cap is broadly convex or nearly flat, viscid when moist and of a peculiar yellowish-brown color, with a slight reddish tint and commonly varied with very obscure streaks or stains of a deeper hue. The flesh is white, often tinged with yellow in old plants. The mass of pores is at first concealed by the membranous veil, which stretches from the stem to the margin of the cap; but when this is ruptured by the expansion of the cap, they are seen to be yellow, but with advancing age they assume dingy ochraceous hues. The stem is shorter than the diameter of the expanded cap, solid, and furnished with a membranous collar which often seems to extend downwards on the stem somewhat like a sheath. It is marked with brown dots above the collar. It is found under pine trees in autumn.

"Edible and highly esteemed;" "its flesh is very tender;" it is excellent," are some of the estimates made of this fungus by European writers.

The small yellowish boletus, *Boletus subluteus*, is a much more common species, but one so closely related to the Yellow-brown boletus that possibly it has often been mistaken for it. It differs from it in having a more slender stem, which is marked with brown or blackish dots both above and below the collar. The

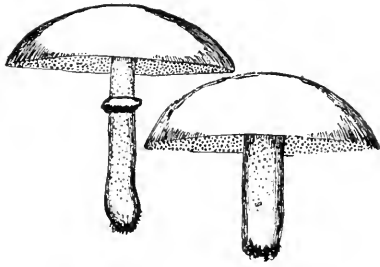

*Boletus subulterus.*

*B. granulatus.*

collar, which is formed by the collapsing of the glutinous veil, is in the form of a thick glutinous band rather than a membrane, and the cap is generally smaller than in that species. In other respects the two species are so much alike that a more extended description of this one is scarcely necessary.

Its cap is two to four inches broad, its stem two to three inches long, and one-fourth to one-third of an inch thick. It occurs in places where pine trees grow or have grown, and is especially fond of a light sandy soil shaded by a thin or scattering growth of young pines. It appears in late summer and in autumn.

The Granulated boletus, *Boletus granulatus*, is another viscid-cap species that delights especially in the company of pine trees and groves. These species are scarcely found at all in regions destitute of pines. The cap of this one is very variable in color, pinkish-gray, grayish-yellow, reddish, reddish-brown and tawny hues prevailing. A spotted appearance is sometimes produced by the drying gluten. The flesh is thick and white except near the stratum of pores, where it is tinted yellow.

The mass of pores is at first pale yellow, but with advancing age it assumes the dingy ochraceous hues common to many species.

The stem is short, solid, whitish, with no collar, but adorned either in its entire length, or on the upper part only with unequal brown dots or granules. These first appear like drops of a thick, turbid juice oozing from the stem, but in a short time they harden and form the brown granules that give origin to the name of the fungus. They also occur on the edges of the partitions between the pores.

The cap varies in size from one and a half to four inches broad, and the stem from one to two inches long, and from one-third to two-thirds of an inch thick.

The Granulated boletus is common in sandy regions where pine trees and thickets are frequent, and occurs from July till cold weather in autumn stops its growth. It grows in groups and sometimes in circles. It is often found in company with the American boletus, *Boletus americanus*, a smaller species with a

bright golden yellow cap, yellowish flesh, and a more slender but similarly dotted stem.

Dr. Cooke says that the Granulated boletus has given him the greatest satisfaction as an edible species, and that he prefers it to the Edible boletus, or indeed to any other species that he has eaten.

## XVI. DRY BOLETI, POLYPORI AND FISTULINA.

The Rough stem or Scabrous-stem boletus, *Boletus scaber*, is our most common species. Its cap varies in color from white to a dark brown or almost black. It is most often some shade of gray, varying to brick-red or pale orange. Its shape also varies from broadly and bluntly conical to convex or flat above, while its surface may be smooth or minutely downy or even obscurely scaly. Its flesh is white or whitish, both it and the mass of



*Boletus scaber.*    *B. edulis.*

pores sometimes assuming pinkish or blackish hues where bruised or wounded. The pore stratum is at first whitish, becoming dingy brown with age. The pores are quite long, and the mass is convex below and much shortened or depressed around the top of the stem. The stem is rather long, often narrowed at or toward the top, solid, whitish, and dotted with numerous small fibrous scales or points which are reddish or blackish, and which are so

small as to give a rough, dotted appearance to the stem. Sometimes scales of both colors are seen on the same stem. This character is a peculiar one, and easily separates this species and the next from all their fellows.

The plant having a white cap was first considered a distinct species and named *Boletus niveus*, but was afterwards made a variety of the Rough-stem boletus. It is sometimes still regarded as distinct. It is rare in this State.

The cap is one to five inches broad and the stem two to five inches long and one-third to two-thirds of an inch thick.

The plant grows everywhere in woods, swamps and open uncultivated places, and on all kinds of soil. It may be found from June to November.

It is not often that a fungus as plentiful as this is as good. My own experiments in eating it were most satisfactory, and it seems to me to be one of the very best of our edible boleti. But some writers do not esteem it so highly, merely pronouncing it edible, or saying that it is less agreeable than the Edible boletus. Gillet says that it can be eaten without the least fear, but that young plants should be selected, as old ones are generally more difficult of digestion.

The Orange-cap boletus, *Boletus versipellis*, takes its name from the color of the cap, which is yellowish-red or orange. It agrees so closely with forms of the Rough-stem boletus, which have reddish or orange-colored caps, that it is scarcely possible to separate them except by the appendicular fragments of the membranous veil, which adhere persistently to the margin of the cap in this species. These strips of membrane are generally inflexed, and cover the mouths of the marginal pores. They are not, therefore, noticed unless they are sought by looking at the lower surface of the cap. In consequence of the close resemblance between the two species, any more extended description of this one is unnecessary. It has the same size, the same color of the pores and the same color ornamentation and character of the stem that belong to the Rough-stem boletus. It is less common with us, and to my taste its flavor is less agreeable.

The Edible boletus, *Boletus edulis*, is a large but not very common species. When young, the cap is firm and the pores are whitish and indistinct, their mouths appearing as if stuffed with a whitish substance; but in older plants the flesh becomes more soft and the pore mouths distinct. The cap varies some in color but is generally reddish-brown or tanny-brown in the centre with paler or yellowish hues toward the margin. The flesh is white, or barely tinged with yellow and of an agreeable nutty flavor. The pore mass, which is whitish in young plants, soon changes to yellowish or greenish-yellow. It is depressed around the stem.

The stem is stout, solid, often a little thickened toward the base, generally even, except toward the top, where it is roughened with minute elevated lines which are connected in a reticulated manner, forming a kind of network style of ornamentation. Its color is usually whitish, buff or yellowish-brown.



The cap is three to six inches broad, the stem two to five inches long and one-half to one and a half inches thick.

The Edible boletus may be found growing in thin woods, groves, bushy or open places in warm wet weather in July and August.

It has long been known as an edible species and holds a place among boleti similar to that held by the Common mushroom among agaries. Badham recommends especially this and the Rough-stem boletus. Gillet says it is an excellent species with an agreeable flavor, and that it is extensively used in France. It is sometimes sliced and dried for future use. In this condition it is chiefly used in the preparation of, and to give flavor to soups and stews.

It is quite good fried in butter. The following simple method of preparation has been published. Remove the stems and pores, cut the cap in small pieces, which place in a dish with butter, salt and pepper; cover and bake an hour.

The Chestnut boletus, *Boletus castaneus*, is unlike any other species here described, in having a hollow stem. This character is not common among boleti.

The cap is convex in the young plant, but it expands with age and sometimes becomes concave above the elevation of its margin. Its surface is commonly covered by a minute, scarcely noticeable velvety down, and its color is tawny or reddish-tawny, approaching bay-red. It is not usually as dark a color as the name would indicate. The stratum of pores is rather thin, at first white or whitish, but yellowish when mature.

The stem is short, often tapering upward, colored and clothed like the cap, soft or spongy within when young, but cavernous or hollow when mature.

The cap is one to three inches broad, the stem one to two inches long and one-fourth to one-half an inch thick. The plant grows in thin woods and in open grassy places, and may be found from July to September. It is not abundant, nor is it generally considered first quality.

Some other species of *Boletus* are classed as edible, but not having tested them it seems better to omit them. Some species of this genus quickly assume blue tints where bruised or wounded. The rule is sometimes given to avoid all such species as poisonous. And yet one correspondent, an enthusiastic fungus-eater, informs me that he eats such species, and has done so repeatedly without harm. Indeed, he says he eats all kinds that he can get except the Bitter boletus, *Boletus fellens*, of which no

kind of preparation seems to destroy the bitter taste. But in one instance which was brought to my notice, sickness and vomiting followed the eating of the Sensitive boletus, *Boletus sensibilis*, a species which assumes blue colors in a remarkable degree where bruised or broken. All the family partaking of it were made sick, but all recovered.

In the genus *Polyporus*, the stratum of pores is not separable from the cap. Most of the species grow on wood, and are too tough to be of any use as food. A few grow on the ground, but even these are inclined to be tough, and though the species are numerous, very few are fit to be classed as edible, and these are not very good except when young and tender. A single example will be given.

The Sulphury polyporus, *Polyporus sulphureus*, is so named because of the bright sulphur yellow color of its stratum of pores. The caps have no well developed stems. They are side growers,

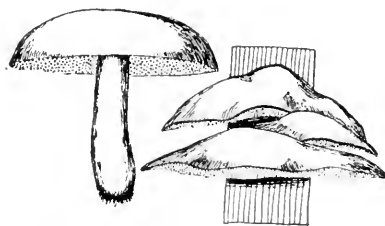

*Boletus castaneus.*     *Polyporus sulphureus.*

and are attached to their place of growth by one side or a part of the margin of the cap. They commonly grow in large clusters, one above another, and side by side, and variously grown together where they come in contact with each other. When fresh, the upper surface of the caps, which is more or less irregular and

uneven, is of a pale reddish or orange color, often tinged with yellow and easily fading with age or in drying. The pores are rather short and so small as to be easily overlooked, but their beautiful clear pale yellow color is much more durable than the color of the upper surface of the cap. The caps are commonly four to six inches broad, and about half an inch thick.

They grow on dead wood of various kinds of trees, and the species has a wide range. The showy clusters are often seen growing from dead spots in the trunks or branches of living trees. Even the fruit trees of our gardens and orchards are sometimes attacked by it. It occurs during summer.

Only young and tender caps should be used for food. Just before or about the time the pores begin to develop, the caps are in the best condition for eating.

In the genus *Fistulina*, the under surface of the cap is covered with minute hollow tubes, which stand vertically and closely side

by side, but they are separate from each other, and do not form a continuous compact mass, as in the genera *Boletus* and *Polyporus*. They are at first very short, and resemble minute warts or papillæ, but they become longer, cylindrical and hollow with age.

We have one species, the Liver fistulina, *Fistulina hepatica*. This name was probably suggested by its dark-red color. It has



*Fistulina hepatica*.

other common names, such as "Oak tongue," "Chestnut tongue," "Beef tongue," and "Beefsteak fungus," given in allusion to its place of growth, its shape or its texture. Like many other wood-inhabiting fungi, it is a "side grower."

Its cap is rough, especially when young, with minute papillæ on the upper surface, and this, with its shape and color, may have suggested the name Beef tongue. Its stem is short, and often quite thick. The flesh is soft and juicy, but tough and fibrous when old and dry. The juice is reddish, and the flesh is streaked with red. The pores or tubes are pinkish or yellowish-pink when young, but they become dingy or brownish-ochraceous when old. The cap is commonly two to six inches broad, but it sometimes attains a much greater size. It grows in warm, wet weather from the base or from stumps of oak and chestnut trees, and may be found from July to September.

This vegetable beefsteak has been highly praised by some European writers, as the following quotations show: "The taste resembles meat in a remarkable manner;" "It is good broiled with a steak and properly seasoned;" "If it is not beef itself, it is the sauce for it;" "No fungus yields a richer gravy, and though rather tough when broiled, it is scarcely to be distinguished from broiled meat." It sometimes has a slightly acid flavor, but this is by no means disagreeable.

## XVII. SPINE-TOOTHED MUSHROOMS, CORNUCOPIAS AND FAIRY CLUBS.

In the genus *Hydnum*, which belongs to the family *Hydneae*, the lower surface of the cap is thickly set with slender pointed spine-like teeth or needles. These take the place of gills in the family *Agaricinæ* and of pores in the family *Polyporæ*. Our species of *Hydnum* are mostly rather tough, and the edible ones are few. Only two are here described:

Teeth on the lower surface of a cap, *H. repandum*.  
Teeth on the lower side of flattened branches, *H. coralloides*.

The spreading hydnum or Hedgehog mushroom, *Hydnum repandum*, is one of our common species. Its cap is more or less irregular, often eccentrically attached to the stem and lobed or wavy on the margin. Its color may be pale-buff, rusty-yellow, pale-red or sienna color. The flesh is compact but rather fragile, whitish and somewhat dry. The spines or teeth are about one-fourth of an inch long, whitish, tinged with yellow or pinkish-yellow. The stem is thick but short and often irregular. It is whitish or at least paler than the cap, which is one to four inches broad, the stem varying from one to three inches long.

This fungus grows in woods or open places, on naked soil or among leaves and moss singly, in groups, or in clusters. It may, be found in July to October.

The Reddish variety, var. *rufescens*, sometimes considered a good species, having the name *Hydnum rufescens*, is smaller, thinner and more regular in shape and more uniformly reddish in color. It grows chiefly in woods, and nearly always has the stem central.

Badham says that the Spreading hydnum is as good as oysters, which it somewhat resembles in taste. Stevenson says it is a most delicious fungus, but requires about four hours of slow cooking. Berkeley pronounces it a most excellent fungus, but one which requires a little caution in its preparation for the table. It is easily dried and preserved for winter use.

One method of cooking it consists in first slicing the caps and steeping them twenty minutes in warm water, then placing in a

stew-pan with butter, salt, pepper and beef gravy, and simmering slowly for an hour.

The Coral-like hydnum, *Hydnum coralloides*, is quite unlike the spreading hydnum in general appearance, and might easily be thought to belong to a distinct genus. Instead of having a cap it is divided into several rather broad, angular or flattened, spreading branches, from whose lower surface the spine-like teeth project. The whole plant is white, and the branches and spines are so numerous and dense that it has been compared to a cauliflower and called the "cauliflower spiny cap." It is often mentioned as "a fungus that looks like coral." The stem is short or almost none, the branches sometimes starting from the very base. The terminal ones frequently curve upwards at their tips and end in a spreading mass of teeth. The teeth vary in length from one-sixth to one-third of an inch, and single plants are generally two to four inches high and nearly as broad, but sometimes they are considerably larger.

It grows on prostrate trunks and decaying wood of various trees, but chiefly on beech. It is found in woods, especially in hilly and mountainous districts, and occurs during rainy or showery weather from August to October.

It is a pretty fungus, and very attractive to those who are neither botanists nor fungus-eaters. And it is as good as it is beautiful. In our botanical expeditions in the vast wilderness of the Adirondack region we were often obliged to camp in the woods several nights in succession. On such occasions this fungus sometimes formed a luxurious addition to our ordinarily simple and sometimes very limited bill of fare.

Two or three other species of *Hydnum* belonging to our flora are classed as edible by some writers, but they have appeared to me to be so dry and tough that trial of them has not been made.

The Gelatinous hydnum or "jelly hedgehog," *Hydnum gelatinosum* of some authors, *Tremellodon gelatinosum* of others, is sometimes eaten raw like a jelly. It is sometimes sweetened with sugar.

In the family *Thelephoraceae*, the lower surface of the cap has neither gills, pores nor teeth, but is even or slightly wrinkled, occasionally obscurely papillose. A single species belonging to the genus *Craterellus* will be described as the representative of this family.

The *Cornucopia craterellus*, sometimes called the Horn of Plenty, *Craterellus cornucopioides*, is not attractive in appear-

ance. Its cap is very narrow and much elongated so that it is trumpet-shaped, or it may be compared to a cornucopia or horn of plenty. It is very thin, dry, hollow, flexible and slightly tough. It is grayish-brown, ash color, dark, smoky brown, or sometimes almost black. The margin is erect or spreading like the margin of a trumpet's mouth, and it may be regular or wavy, folded, lobed or split. The surface is usually slightly marked or roughened by a few fibrous tufts or scales. The cavity of the cap extends to its base. The lower or spore-bearing surface, which, from the shape of the cap, becomes rather the outer or

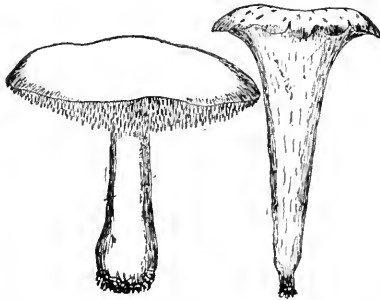

*Hydnum repandum.*      *Craterellus cornucopioides.*

external surface, is a little uneven or wrinkled and is colored similar to but often a little paler than the upper surface. The stem is extremely short or almost wanting.

The plant is two to four inches high and one to two inches broad at the top. It grows gregariously or in clusters in woods and shady places, on naked earth and

banks or among moss and fallen leaves. A favorite place of growth is in or along old abandoned or unused roads in woods. It may be found from July to September, and probably later in the season in more southern localities.

Several French writers record this as edible, but admit that it is not very popular because of its thin flesh and dark color. Dr. Cooke says that his first trial was so satisfactory that he never missed an opportunity afterwards of gathering it for the table, and he says that a friend, who learned from him of its edible qualities, now thinks nothing of walking six or eight miles to procure a dish of it.

The last family to be here noticed is the *Clavariaceae*, and the genus to which our edible species belong is *Clavaria*. This name is derived from the Latin word *clava*, which means a club. It has reference to the shape of some of the plants belonging to this genus. The plants are sometimes called "fairy clubs." No cap is present in these plants. They are more like simple or branched stems without caps. The simple ones are sometimes gradually thickened toward the top, and therefore club-shaped; the branching plants are often so abundantly supplied with

branches that they are bush-like in form. In color they vary from white to yellow, ochraceous, tan color, red or purple, but no black species are known, although similarly shaped species of a black color belong to some other families of fungi. Several species of this genus are recorded as edible, and no species is known to be dangerously harmful, yet many are too small or too insipid or disagreeable to be of value as food. Three species will here be described :

Plant simple, club-shaped,	<i>C. pistillaris</i> ,
Plant branched, bush-shaped,	1.
1. Tips of the branches red,	<i>C. botrytes</i> ,
1. Tips of the branches yellow,	<i>C. flava</i> ,

The Pistil clavaria or Large Club, *Clavaria pistillaris*, is the largest of our unbranched species. It is commonly three to five inches high, and one-half to two-thirds of an inch thick at the top, where it is rounded or very blunt. It gradually tapers downward to the base. Its surface is smooth, and its color yellowish or ochraceous, sometimes with a reddish tint. The flesh is soft and white. Sometimes irregular or very short, thick forms occur, and in Europe it is said to reach the height of twelve inches, but I have seen no American plants so tall. It grows in grassy, open places, or in thin woods and groves, in wet weather in summer. I have not eaten it, and introduce it on the recommendation of others, and as a representative of the simple forms of the genus.

The Red-tipped clavaria *Clavaria botrytes*, has a very short, thick, fleshy white stem, which suddenly divides above into a very dense or compact mass of erect or ascending branches, the tips of which are of a red color, at least while young and fresh. This is a good mark by which to recognize this species. The branches are elsewhere whitish or pale yellow, and when old, even the tips fade and lose their primary color. The plants are commonly three to five inches high, and two to four inches broad, the stem being about an inch thick. It grows in thin woods and in open places, in wet or showery weather, from July to September.

Mycologists agree in ascribing to this fungus delicious qualities and an agreeable flavor. Unfortunately, it is not common with us.

The Pale yellow clavaria, *Clavaria flava*, is very similar to the Red-tipped clavaria, but is at once distinguished by its having yellow-tipped branches. Its stem is short and thick, and is abruptly dissolved above into a dense mass of nearly parallel erect

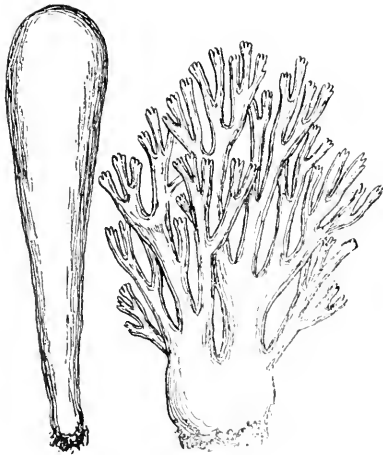

*Clavaria pistillaris.* *C. flava.*

branches. The yellow tips of these fade with age, and then it becomes difficult to distinguish this species from old plants of the preceding one. The branches below the tips are whitish, or a paler yellow than the tips; the stem also is white or whitish, and the flesh is white and of a pleasant flavor. The flavor is greatly affected by the attacks of insects. A few larvæ burrowing in the base of the stem will impart to the untouched branches above a very disagreeable and almost nauseating taste. It

is therefore important in selecting plants for the table, not only of this species, but of others also, to exercise care and to discard all that have been invaded by larvæ.

This *Clavaria* grows in thin woods and open places in warm, wet weather in summer and early autumn and is more common than either of the preceding species. My experiments in eating it lead me to recommend it highly. Its flesh is tender and well-flavored, and nothing better could be desired by the mycophagist. Roques says it furnishes a healthful food and is easy of digestion.

The Golden clavaria, *Clavaria aurea*, bears a general resemblance to it, but its stem is thinner, its branches are more highly colored and often longitudinally wrinkled, and their tips are not different in color from the rest of the branch. Still no great harm could come from mistaking it for the Pale yellow clavaria, for it also is deemed edible. Several other edible species not having been proved by us are omitted.

In the family Tremellineæ the substance of the fungus is tremelloid or gelatinous, and the plants are mostly stemless irregular masses or expansions. The most important edible species is one called the "Jew's ear," *Hirneola auricula-judae*, which is extensively used in China, but which is not abundant here, and which is probably of but little value.

NOTE.—The cuts illustrating this work are loaned by the *Country Gentleman* of Albany, N. Y.



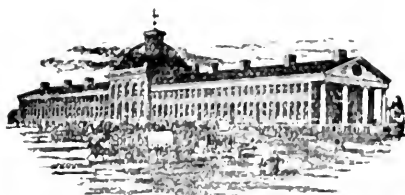

# ⇒ MUSHROOMS, ⇐

ANY QUANTITY AT ANY TIME.

*FRUITS AND VEGETABLES.*

Special attention given to Hotel, Club, and Family Orders.

**ISAAC LOCKE & CO.,** 97, 99 and 101 FANEUIL HALL MARKET,  
BOSTON, MASS.

## Mushrooms in Shredded Wheat Biscuit Baskets.

1 can mushrooms (Champignons), 2 bouillon capsules,  $1\frac{1}{2}$  tablespoons butter, 1 tablespoon chopped carrot, 1 bay leaf, a little parsley,  $1\frac{1}{2}$  tablespoons Entire Wheat Flour, 1 tablespoon chopped onion,  $\frac{1}{2}$  cup heavy cream,  $1\frac{1}{2}$  cups boiling water, 5 Shredded Wheat Biscuit. Salt to taste.

Melt the butter in a saucepan, add the carrot, onion, bay leaf, and parsley. Cook ten minutes, being careful that it does not burn. Then add the flour, stir in a little at a time the boiling water in which the capsules have been dissolved. When it thickens, strain, return to saucepan and add the mushrooms which have been drained and cut into thirds. Cook five minutes and add  $\frac{1}{2}$  cup cream; then keep hot but do not cook. Prepare the biscuit by cutting with sharp pointed knife an oblong cavity in the top of the biscuit, cutting about  $\frac{1}{4}$  inch from sides and ends; carefully remove top and take out all loose inside shreds, making basket shape. Place in a pan and toast lightly in oven, then fill with the prepared mushrooms. Cover with the caps removed from the biscuit, and return to the oven; heat through, remove to a warm platter, remove the cap, garnish with parsley and quarters of lemon. Send to table with remaining sauce served in gravy boat or pitcher to be added at the table.

A handsome cook-book, entitled "The Vital Question," containing daily family, also party or banquet menus and general rules for cooking by the New Method, a sample recipe of which appears above, will be mailed to any address on receipt of only six 2-cent stamps. The Mushroom eater will find genuine comfort in reading "The Vital Question." It teaches that natural foods make natural conditions and natural proportions.

ADDRESS

**THE NEW ERA COOKING SCHOOL,**  
55 JACKSON STREET,  
WORCESTER, MASS.

**THE**  
**AMERICAN KITCHEN MAGAZINE**

published in February, 1897, a list of Edible Fungi collected by the Boston Mycological Club.

Magazines containing this list may be obtained for 10 cents each.



MRS. ANNIE P. DOUGHTY, has furnished several papers on seasonable mushrooms for spring, summer, and fall; and the June and July issues (1897) will contain two of her recent lectures before the . . . Boston Mycological Club. . .



SEND ORDERS TO  
**THE HOME SCIENCE PUBLISHING CO.,**  
485 Tremont Street  
*BOSTON, MASS.*

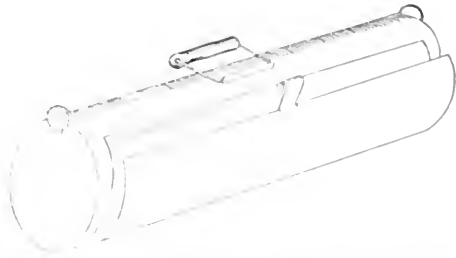

## Collecting Boxes, Gray Herbarium Patterns.

The cut represents the simpler pattern: size 4 x 6½ x 18, japanned inside and out; list price, \$1.26.

Same, larger size, 5½ x 8½ x 19, with end compartments, list price, \$2.21.

## BEST MUSHROOM BOOKS.

COOKE: British Edible Fungi, 237 pages, 12 colored plates, illustrating over 40 edible species . . . . . \$2.50

MICHAEL: Führer für Pilzfreunde, fine plates, especially of Boletus . . . . . 1.75

## CHAPMAN'S FLORA OF THE SOUTHERN UNITED STATES.

The Manual of Botany for the region south of Virginia and Kentucky.  
Third edition, March 12, 1897. Postpaid, \$4.00.

Gummed Paper for use in pressing sliced specimens of Mushrooms after Herpel's method.

Colored papers for spore prints of Mushrooms.

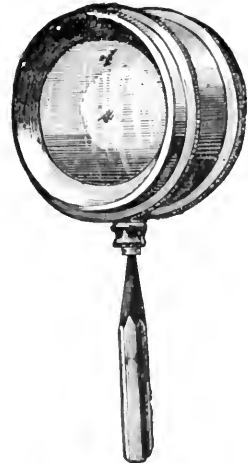

## Lenses, Microscopes,

Instruments of all kinds for Botanical Work.

CAMBRIDGE BOTANICAL SUPPLY COMPANY.

1286 Massachusetts Avenue (Opposite College Library), Cambridge, Mass.

EVERYTHING USEFUL TO BOTANISTS.

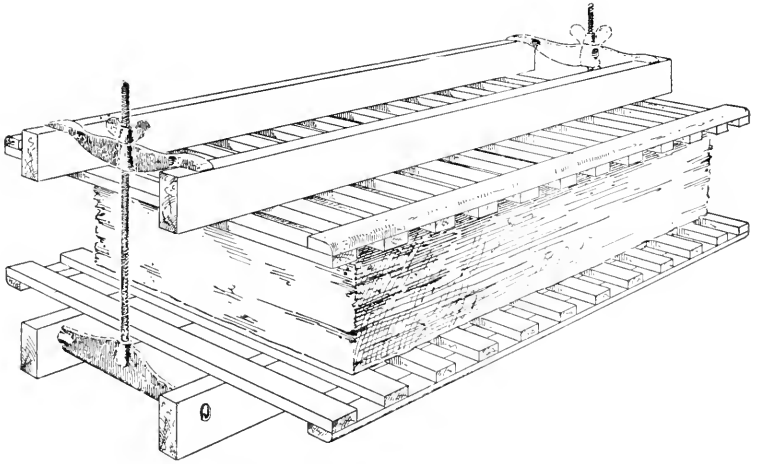

### **WATSON PRESS.**

We offer a screw press of new pattern designed by Mr. Thos. A. Watson. It is made of mahogany and consists of two frames of slats and two pairs of unattached cleats, to which pressure is applied by means of an iron screw at each end.

The construction is extremely simple. The press is light and strong and as all the parts are detachable, it can be packed snugly for travelling. The slats can be used alone as a portable press. List price, \$2.52.

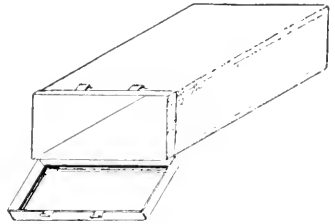
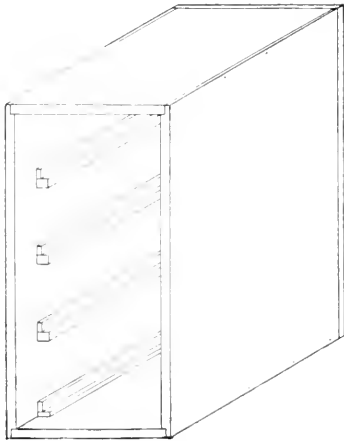

### **CASES WITH TIN PIGEON-HOLES FOR HERBARIA.**

Proof against insects, dust, moisture, scorching; specially suited to dried specimens of Mushrooms. Each tin, list, \$1.06. Wooden case for four, list, \$3.13.

Pasteboard boxes of fractional sizes to fit the above, for thick specimens. Prices on application.

**CAMBRIDGE BOTANICAL SUPPLY COMPANY,**  
**1286 Massachusetts Avenue (Opposite College Library), Cambridge, Mass.**  
**EVERYTHING USEFUL TO BOTANISTS.**

## LIST OF WORKS ON MUSHROOMS.

In addition to the following many old and rare works and special papers can be supplied in single copies, including works of Bulliard, Sowerby, Badham, Hussey, Gillet, Patouillard and others (subject to previous sale). Importations to order at prices of European dealers. All new works as issued.

Prices do not, as a rule, include postage.

BOSTON MYCOLOGICAL SOCIETY. Edible Fungi	.10
Account of species eaten in 1896.	
BURT. Anthurus .....	1.00
Mutinus.....	.40
Phalloideæ U. S. 2 pts..	.50
CILARTS. Photo-enlargements, lantern slides or diagrams to order.	
CLARKE. Photographs of mushrooms, each 15c, or blue-prints, 5c.	
COOKE. British Edible Fungi. Fine plates and list of 200 edible species .....	2.50
Edible and Poisonous Mushrooms.—A smaller work with plates .....	1.50
Illustrations of British Fungi.—76 pts., 1198 colored plates.	
Mycographia.—Discomycetes, 113 col. plates.....	18.00
Introduction to the Study of Fungi.....	4.55
Plain and Easy Account of British Fungi. Illustrated.	1.50
COOKE AND BERKELEY. Fungi, Their Nature, Influence and Uses. Illustrated. Contains remarks on the edible species of the United States.....	1.50
COOKE AND QUELET. Clavis Synoptica Hymenomycetum Europæorum .....	1.00
COSTANTIN. Atlas des Champignons comestibles et vénéneux. 228 colored figures.....	1.00
COSTANTIN ET DUFOUR. Nouv. Flore des Champignons. Paris, 1891. 3842 fig .....	1.00
Same. Second ed. Paris, 1895. 4166 fig.....	1.50
Petite Flore d. Champignons comest. et vénén. Paris, 1895. 351 fig .....	.75
FALCONER. Mushrooms; how to grow them.....	1.50
FARLOW. Notes for Mushroom Eaters.....	.25
FRIES. Hymenomycetes Europæi. A systematic descriptive work in Latin. The basis of all recent works.	
GIBSON: Mushrooms. Finely illustrated. List price..	7.50
HERBARIUM. Numbered list for arranging genera....	.05
Numbered labels for genera. Large type.....	.85
HERPEL. Sammlung präparirter Hutpilze. Excellent specimens of 135 species.....	25.00
Präpariren und Einlegen der Hutpilze für das Herbarium	.60

JOURNAL OF MYCOLOGY. Vols I-VII. Complete.	
Chiefly devoted to microscopic fungi and plant diseases	10.00
LAPLANCHE. Dictionnaire Iconographique des Champignons	
Supér. An index of plates.....	2.50
LEIGHTON. Mushrooms, Lichens and Moulds. 1895.	.35
MACBRIDE AND ALLIN. The Saprophytic Fungi of Eastern	
Iowa. The Puff-Balls .....	.50
MASSEE. British Fungus Flora. 4 vols. Sold separately if	
desired. One of the best systematic works. Each volume	2.00
MICHAEL. Führer für Pilzfreunde. Fine plates, especially	
of Boletus .....	1.75
MONTAGNE. Sylloge Cryptogamarum .....	3.50
MORGAN. North American Fungi. Gasteromycetes. 5	
pts .....	1.25
PALMER. Mushrooms of America, edible and poisonous. 12	
colored illustrations .....	2.00
PECK. Fungi and Their Use. Reprinted from <i>Country Gen-</i>	
<i>tleman</i> . "The best introduction to the study of mushrooms."	
Postpaid .....	.50
Reports New York Museum. All obtainable supplied.	
Bulletins New York Museum.	
No. 2 .....	.25
No. 8 Boletus.....	.25
PHILLIPS. A Manual of the British Discomycetes. London,	
1887. Plates .....	1.50
SACCARDO. Chromotaxia .....	.60
SMITH. Clavis Agaricinarum.	
STEVENSON. British Hymenomycetes. One of the best	
systematic descriptive works. 2 vols.....	8.06
STREINZ. Nomenclator Fungorum. Index to descriptions,	
complete to 1862.....	2.50
TAYLOR. Student's Hand Book of Mushrooms of America,	
edible and poisonous. Comprises substance of "Food Pro-	
duct" pamphlets of Dept. of Agr. by same author. 5 pts.	
promised, first in May, last in August, 1897. Each....	.50
WEBSTER. Structure of Fungi. A lecture.....	.10
WINTER. Basidiomycetes of Rabenhorst's Kryptogamen	
Flora .....	8.00
WRIGHT. Mushrooms for the Million. Methods of growing	
mushrooms .....	.50

CAMBRIDGE BOTANICAL SUPPLY COMPANY,

1286 Massachusetts Avenue, (Opposite College Library), Cambridge, Mass.

EVERYTHING USEFUL TO BOTANISTS.











New York Botanical Garden Library

gen

QK617 .P32  
Peck, Charles Horta/Mushrooms and their



3 5185 00064 1884

